



# TSH80-TSH81-TSH82

## Wide Band, Rail-to-Rail Operational Amplifier with Standby Function

- **4.5V, 12V** operating conditions
- 3dB-bandwidth: 100MHz
- Slew-rate: **100V/μs**
- Output current: up to **55mA**
- Input single supply voltage
- Output rail-to-rail
- Specified for 150Ω load
- Low distortion, THD: **0.1%**
- SOT23-5, TSSOP and SO packages

### Description

The TSH8x series offers single and dual operational amplifiers featuring high video performances with large bandwidth, low distortion and excellent supply voltage rejection. These amplifiers feature also large output voltage swing and high output current capability to drive standard 150Ω loads.

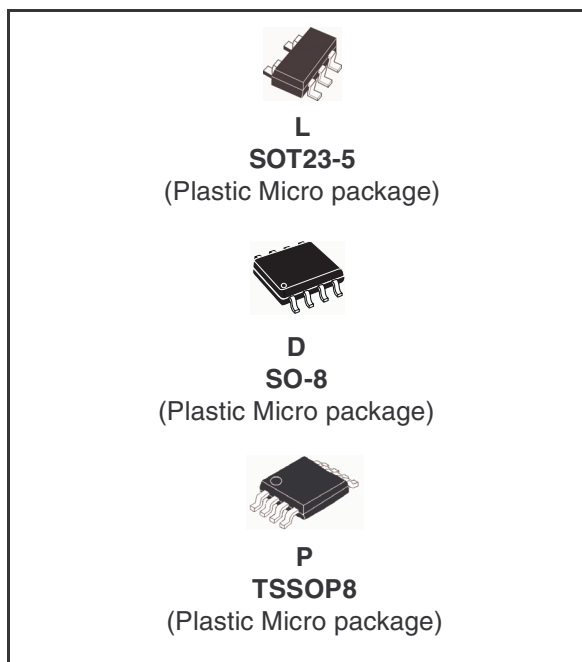
Running at single or dual supply voltage from 4.5V to 12V, these amplifiers are tested at 5V(±2.5V) and 10V(±5V) supplies.

The TSH81 also features a standby mode, which allows the operational amplifier to be put into a standby mode with low power consumption and high output impedance. The function allows power saving or signals switching/multiplexing for high speed applications and video applications.

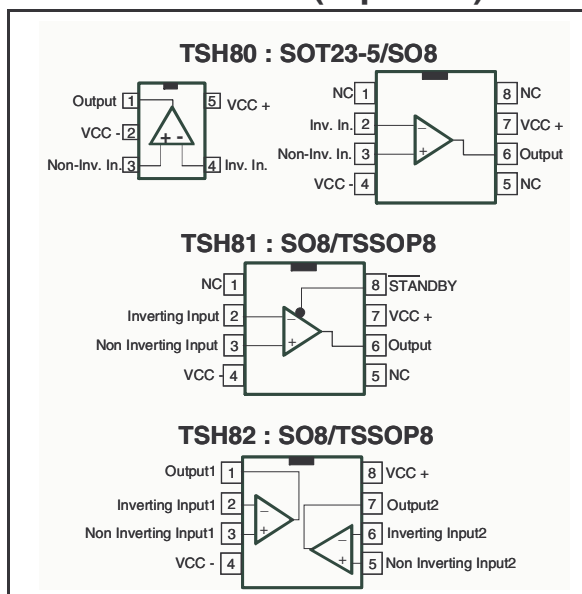
For board space and weight saving, TSH8x series is proposed in SOT23-5, TSSOP8 and SO-8 packages.

### Application

- Video buffers
- A/D converters driver
- Hi-Fi applications



### Pin Connections (top view)



## Order Codes

Type	Temperature Range	Package	Packaging	Marking
TSH80ILT	-40°C to +85°C	SOT23-5	Tape & Reel	K303
TSH80IYLT		SOT23-5 (automotive grade level)		K310
TSH80ID/DT		SO-8	Tube or Tape & Reel	TSH80I
TSH80IYD/IYDT	SO-8 (automotive grade level)	SH80IY		
TSH81ID/DT	-40°C to +85°C	SO-8	Tube or Tape & Reel	TSH81I
TSH81IPT		TSSOP8		Tape & Reel
TSH82ID/DT		SO-8	Tube or Tape & Reel	TSH82I
TSH82IPT		TSSOP8	Tape & Reel	SH82I
TSH82IYD/ITDT		SO-8 (automotive grade level)	Tube or Tape & Reel	SH82IY

# 1 Absolute Maximum Ratings

**Table 1. Key parameters and their absolute maximum ratings**

Symbol	Parameter	Value	Unit
$V_{CC}$	Supply Voltage <sup>(1)</sup>	14	V
$V_{id}$	Differential Input Voltage <sup>(2)</sup>	$\pm 2$	V
$V_i$	Input Voltage <sup>(3)</sup>	$\pm 6$	V
$T_{oper}$	Operating Free Air Temperature Range	-40 to +85	°C
$T_{stg}$	Storage Temperature	-65 to +150	°C
$T_j$	Maximum Junction Temperature	150	°C
$R_{thjc}$	Thermal resistance junction to case <sup>(4)</sup>		
	SOT23-5	80	°C/W
	SO8	28	
TSSOP08	37		
$R_{thja}$	Thermal resistance junction to ambient area		
	SOT23-5	250	°C/W
	SO8	157	
TSSOP08	130		
ESD	Human Body Model	2	kV

1. All voltage values, except differential voltage are with respect to network ground terminal
2. Differential voltages are non-inverting input terminal with respect to the inverting terminal
3. The magnitude of input and output must never exceed  $V_{CC} + 0.3V$
4. Short-circuits can cause excessive heating

**Table 2. Operating conditions**

Symbol	Parameter	Value	Unit
$V_{CC}$	Supply Voltage	4.5 to 12	V
$V_{IC}$	Common Mode Input Voltage Range	$V_{CC}^-$ to $(V_{CC}^+ - 1.1)$	V
Standby		$(V_{CC}^-)$ to $(V_{CC}^+)$	V

## 2 Electrical Characteristics

Table 3.  $V_{CC}^+ = +5V$ ,  $V_{CC}^- = GND$ ,  $V_{ic} = 2.5V$ ,  $T_{amb} = 25^\circ C$  (unless otherwise specified)

Symbol	Parameter	Test Condition	Min.	Typ.	Max.	Unit
$ V_{io} $	Input Offset Voltage	$T_{amb} = 25^\circ C$ $T_{min.} < T_{amb} < T_{max.}$		1.1	10 12	mV
$\Delta V_{io}$	Input Offset Voltage Drift vs. Temperature	$T_{min.} < T_{amb} < T_{max.}$		3		$\mu V/^\circ C$
$I_{io}$	Input Offset Current	$T_{amb} = 25^\circ C$ $T_{min.} < T_{amb} < T_{max.}$		0.1	3.5 5	$\mu A$
$I_{ib}$	Input Bias Current	$T_{amb} = 25^\circ C$ $T_{min.} < T_{amb} < T_{max.}$		6	15 20	$\mu A$
$C_{in}$	Input Capacitance			0.3		pF
$I_{CC}$	Supply Current per Operator	$T_{amb} = 25^\circ C$ $T_{min.} < T_{amb} < T_{max.}$		8.2	10.5 11.5	mA
CMR	Common Mode Rejection Ratio ( $\delta V_{ic}/\delta V_{io}$ )	$+0.1 < V_{ic} < 3.9V$ & $V_{out}=2.5V$ $T_{amb} = 25^\circ C$ $T_{min.} < T_{amb} < T_{max.}$	72 70	97		dB
SVR	Supply Voltage Rejection Ratio ( $\delta V_{CC}/\delta V_{io}$ )	$T_{amb} = 25^\circ C$ $T_{min.} < T_{amb} < T_{max.}$	68 65	75		dB
PSR	Power Supply Rejection Ratio ( $\delta V_{CC}/\delta V_{out}$ )	Positive & Negative Rail		75		dB
$A_{vd}$	Large Signal Voltage Gain	$R_L=150\Omega$ to 1.5V $V_{out}=1V$ to 4V $T_{amb} = 25^\circ C$ $T_{min.} < T_{amb} < T_{max.}$	75 70	84		dB
$I_o$	Output Short Circuit Current Source	$T_{amb}=25^\circ C$ $V_{id}=+1, V_{out}$ to 1.5V $V_{id}=-1, V_{out}$ to 1.5V  Source  Sink $T_{min.} < T_{amb} < T_{max.}$ $V_{id}=+1, V_{out}$ to 1.5V $V_{id}=-1, V_{out}$ to 1.5V  Source  Sink	35 33  28 28	55 55		mA

Table 3.  $V_{CC}^+ = +5V$ ,  $V_{CC}^- = GND$ ,  $V_{ic} = 2.5V$ ,  $T_{amb} = 25^\circ C$  (unless otherwise specified)

Symbol	Parameter	Test Condition	Min.	Typ.	Max.	Unit
$V_{oh}$	High Level Output Voltage	$T_{amb}=25^\circ C$ $R_L = 150\Omega$ to GND $R_L = 600\Omega$ to GND $R_L = 2k\Omega$ to GND $R_L = 10k\Omega$ to GND  $R_L = 150\Omega$ to 2.5V $R_L = 600\Omega$ to 2.5V $R_L = 2k\Omega$ to 2.5V $R_L = 10k\Omega$ to 2.5V  $T_{min.} < T_{amb} < T_{max.}$ $R_L = 150\Omega$ to GND $R_L = 150\Omega$ to 2.5V	4.2       4.1 4.4	4.36 4.85 4.90 4.93  4.66 4.90 4.92 4.93		V
$V_{ol}$	Low Level Output Voltage	$T_{amb}=25^\circ C$ $R_L = 150\Omega$ to GND $R_L = 600\Omega$ to GND $R_L = 2k\Omega$ to GND $R_L = 10k\Omega$ to GND  $R_L = 150\Omega$ to 2.5V $R_L = 600\Omega$ to 2.5V $R_L = 2k\Omega$ to 2.5V $R_L = 10k\Omega$ to 2.5V  $T_{min.} < T_{amb} < T_{max.}$ $R_L = 150\Omega$ to GND $R_L = 150\Omega$ to 2.5V		48 54 55 56  220 105 76 61	150     400     200 450	mV
GBP	Gain Bandwidth Product	$F=10MHz$ $A_{VCL}=+11$ $A_{VCL}=-10$		65 55		MHz
Bw	Bandwidth @ -3dB	$A_{VCL}=+1$ $R_L=150\Omega$ to 2.5V		87		MHz
SR	Slew Rate	$A_{VCL}=+2$ $R_L=150\Omega // C_L$ to 2.5V $C_L = 5pF$ $C_L = 30pF$	60	104 105		V/ $\mu s$
$\phi_m$	Phase Margin	$R_L=150\Omega // 30pF$ to 2.5V		40		$^\circ$
en	Equivalent Input Noise Voltage	$F=100kHz$		11		nV/ $\sqrt{Hz}$
THD	Total Harmonic Distortion	$A_{VCL}=+2$ , $F=4MHz$ $R_L=150\Omega // 30pF$ to 2.5V $V_{out}=1V_{pp}$ $V_{out}=2V_{pp}$		-61 -54		dB

**Table 3.**  $V_{CC}^+ = +5V$ ,  $V_{CC}^- = GND$ ,  $V_{ic} = 2.5V$ ,  $T_{amb} = 25^\circ C$  (unless otherwise specified)

Symbol	Parameter	Test Condition	Min.	Typ.	Max.	Unit
IM2	Second order inter modulation product	$A_{VCL}=+2$ , $V_{out}=2V_{pp}$ $R_L=150\Omega$ to 2.5V Fin1=180kHz, Fin2=280kHz spurious measurement @100kHz		-76		dBc
IM3	Third order inter modulation product	$A_{VCL}=+2$ , $V_{out}=2V_{pp}$ $R_L=150\Omega$ to 2.5V Fin1=180kHz, Fin2=280kHz spurious measurement @400kHz		-68		dBc
$\Delta G$	Differential gain	$A_{VCL}=+2$ , $R_L=150\Omega$ to 2.5V F=4.5MHz, $V_{out}=2V_{pp}$		0.5		%
Df	Differential phase	$A_{VCL}=+2$ , $R_L=150\Omega$ to 2.5V F=4.5MHz, $V_{out}=2V_{pp}$		0.5		°
Gf	Gain Flatness	F=DC to 6MHz, $A_{VCL}=+2$		0.2		dB
Vo1/Vo2	Channel Separation	F=1MHz to 10MHz		65		dB

**Table 4.**  $V_{CC}^+ = +5V$ ,  $V_{CC}^- = -5V$ ,  $V_{ic} = GND$ ,  $T_{amb} = 25^\circ C$  (unless otherwise specified)

Symbol	Parameter	Test Condition	Min.	Typ.	Max.	Unit
$ V_{io} $	Input Offset Voltage	$T_{amb} = 25^\circ C$ $T_{min.} < T_{amb} < T_{max.}$		0.8	10 12	mV
$\Delta V_{io}$	Input Offset Voltage Drift vs. Temperature	$T_{min.} < T_{amb} < T_{max.}$		2		$\mu V/^\circ C$
$I_{io}$	Input Offset Current	$T_{amb} = 25^\circ C$ $T_{min.} < T_{amb} < T_{max.}$		0.1	3.5 5	$\mu A$
$I_{ib}$	Input Bias Current	$T_{amb} = 25^\circ C$ $T_{min.} < T_{amb} < T_{max.}$		6	15 20	$\mu A$
$C_{in}$	Input Capacitance			0.7		pF
$I_{CC}$	Supply Current per Operator	$T_{amb} = 25^\circ C$ $T_{min.} < T_{amb} < T_{max.}$		9.8	12.3 13.4	mA
CMR	Common Mode Rejection Ratio ( $\delta V_{ic}/\delta V_{io}$ )	-4.9 < $V_{ic}$ < 3.9V & $V_{out}=GND$ $T_{amb} = 25^\circ C$ $T_{min.} < T_{amb} < T_{max.}$	81 72	106		dB
SVR	Supply Voltage Rejection Ratio ( $\delta V_{CC}/\delta V_{io}$ )	$T_{amb} = 25^\circ C$ $T_{min.} < T_{amb} < T_{max.}$	71 65	77		dB

Table 4.  $V_{CC}^+ = +5V$ ,  $V_{CC}^- = -5V$ ,  $V_{ic} = GND$ ,  $T_{amb} = 25^\circ C$  (unless otherwise specified)

Symbol	Parameter	Test Condition	Min.	Typ.	Max.	Unit
PSR	Power Supply Rejection Ratio ( $\delta V_{CC}/\delta V_{out}$ )	Positive & Negative Rail		75		dB
$A_{vd}$	Large Signal Voltage Gain	$R_L = 150\Omega$ to GND $V_{out} = -4$ to $+4$ $T_{amb} = 25^\circ C$ $T_{min.} < T_{amb} < T_{max.}$	75 70	86		dB
$I_o$	Output Short Circuit Current Source	$T_{amb} = 25^\circ C$ $V_{id} = +1$ , $V_{out}$ to 1.5V $V_{id} = -1$ , $V_{out}$ to 1.5V  Source  Sink $T_{min.} < T_{amb} < T_{max.}$ $V_{id} = +1$ , $V_{out}$ to 1.5V $V_{id} = -1$ , $V_{out}$ to 1.5V  Source  Sink	35 30	55 55		mA
$V_{oh}$	High Level Output Voltage	$T_{amb} = 25^\circ C$ $R_L = 150\Omega$ to GND $R_L = 600\Omega$ to GND $R_L = 2k\Omega$ to GND $R_L = 10k\Omega$ to GND  $T_{min.} < T_{amb} < T_{max.}$ $R_L = 150\Omega$ to GND	4.2    4.1	4.36 4.85 4.9 4.93		V
$V_{ol}$	Low Level Output Voltage	$T_{amb} = 25^\circ C$ $R_L = 150\Omega$ to GND $R_L = 600\Omega$ to GND $R_L = 2k\Omega$ to GND $R_L = 10k\Omega$ to GND  $T_{min.} < T_{amb} < T_{max.}$ $R_L = 150\Omega$ to GND		-4.63 -4.86 -4.9 -4.93	-4.4   -4.3	mV
GBP	Gain Bandwidth Product	$F = 10MHz$ $A_{VCL} = +11$ $A_{VCL} = -10$		65 55		MHz
Bw	Bandwidth @ -3dB	$A_{VCL} = +1$ $R_L = 150\Omega // 30pF$ to GND		100		MHz
SR	Slew Rate	$A_{VCL} = +2$ $R_L = 150\Omega // C_L$ to GND $C_L = 5pF$ $C_L = 30pF$	68	117 118		V/ $\mu s$
$\phi_m$	Phase Margin	$R_L = 150\Omega$ to gnd		40		$^\circ$

Table 4.  $V_{CC}^+ = +5V$ ,  $V_{CC}^- = -5V$ ,  $V_{ic} = GND$ ,  $T_{amb} = 25^\circ C$  (unless otherwise specified)

Symbol	Parameter	Test Condition	Min.	Typ.	Max.	Unit
en	Equivalent Input Noise Voltage	F=100kHz		11		nV/ $\sqrt{Hz}$
THD	Total Harmonic Distortion	$A_{VCL}=+2$ , F=4MHz $R_L=150\Omega // 30pF$ to gnd $V_{out}=1V_{pp}$ $V_{out}=2V_{pp}$		-61 -54		dB
IM2	Second order inter modulation product	$A_{VCL}=+2$ , $V_{out}=2V_{pp}$ $R_L=150\Omega$ to gnd Fin1=180kHz, Fin2=280KHz spurious measurement @100kHz		-76		dBc
IM3	Third order inter modulation product	$A_{VCL}=+2$ , $V_{out}=2V_{pp}$ $R_L=150\Omega$ to gnd Fin1=180kHz, Fin2=280KHz spurious measurement @400kHz		-68		dBc
$\Delta G$	Differential gain	$A_{VCL}=+2$ , $R_L=150\Omega$ to gnd F=4.5MHz, $V_{out}=2V_{pp}$		0.5		%
Df	Differential phase	$A_{VCL}=+2$ , $R_L=150\Omega$ to gnd F=4.5MHz, $V_{out}=2V_{pp}$		0.5		$^\circ$
Gf	Gain Flatness	F=DC to 6MHz, $A_{VCL}=+2$		0.2		dB
Vo1/Vo2	Channel Separation	F=1MHz to 10MHz		65		dB



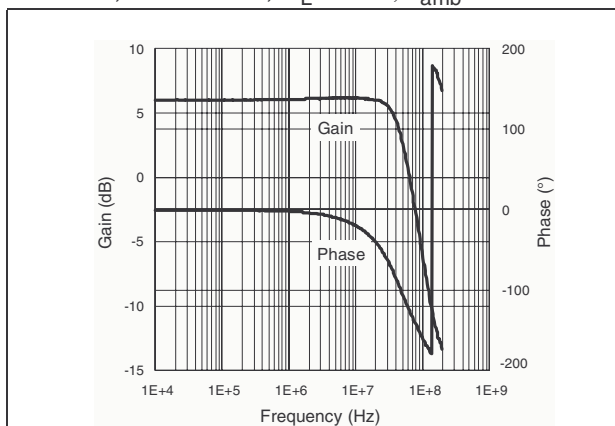
**Table 5. Standby mode**  
 $V_{CC}^+, V_{CC}^-, T_{amb} = 25^\circ\text{C}$  (unless otherwise specified)

Symbol	Parameter	Test Condition	Min.	Typ.	Max.	Unit
$V_{low}$	Standby Low Level		$V_{CC}^-$		$(V_{CC}^- + 0.8)$	V
$V_{high}$	Standby High Level		$(V_{CC}^- + 2)$		$(V_{CC}^+)$	V
$I_{CC\ SBY}$	Current Consumption per Operator when STANDBY is Active	pin 8 (TSH81) to $V_{CC}^-$		20	55	$\mu\text{A}$
$Z_{out}$	Output Impedance ( $R_{out}/C_{out}$ )	$R_{out}$ $C_{out}$		10 17		$\text{M}\Omega$ $\text{pF}$
$T_{on}$	Time from Standby Mode to Active Mode			2		$\mu\text{s}$
$T_{off}$	Time from Active Mode to Standby Mode	Down to $I_{CC\ SBY} = 10\mu\text{A}$		10		$\mu\text{s}$

TSH81 STANDBY CONTROL pin 8 ( $\overline{\text{SBY}}$ )	OPERATOR STATUS
$V_{low}$	Standby
$V_{high}$	Active

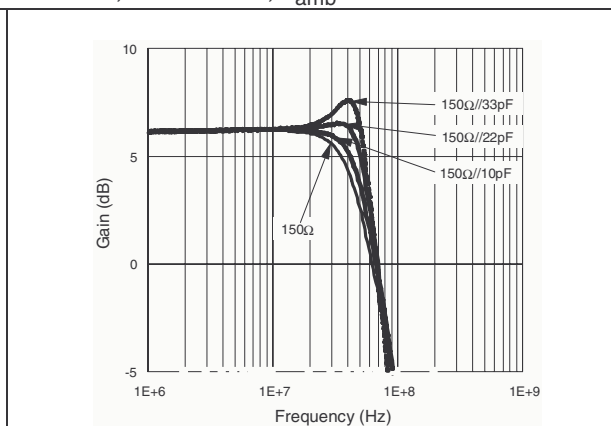
**Figure 1. Closed loop gain & phase vs. frequency**

Gain=+2,  $V_{CC} = \pm 2.5V$ ,  $R_L = 150\Omega$ ,  $T_{amb} = 25^\circ C$



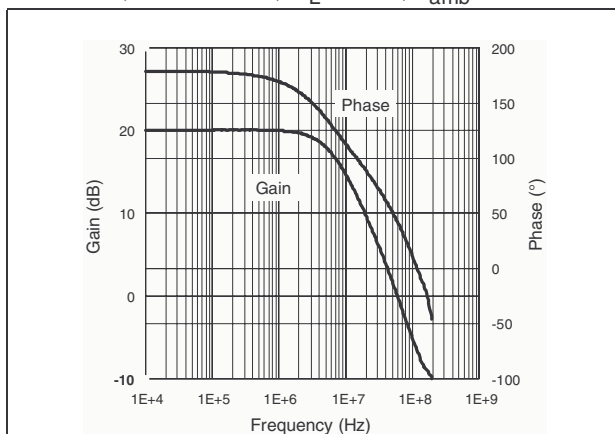
**Figure 2. Overshoot function of output capacitance**

Gain=+2,  $V_{CC} = \pm 2.5V$ ,  $T_{amb} = 25^\circ C$



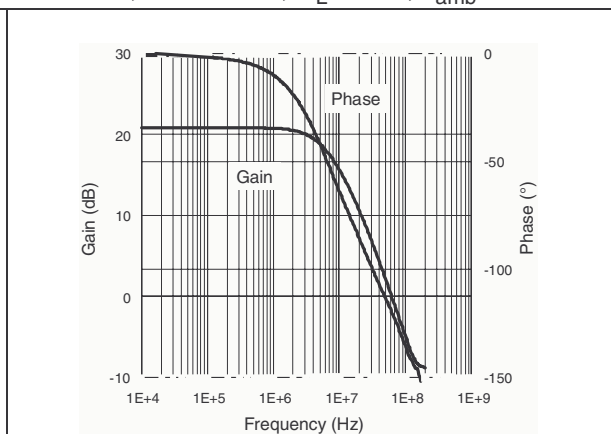
**Figure 3. Closed loop gain & phase vs. frequency**

Gain=-10,  $V_{CC} = \pm 2.5V$ ,  $R_L = 150\Omega$ ,  $T_{amb} = 25^\circ C$



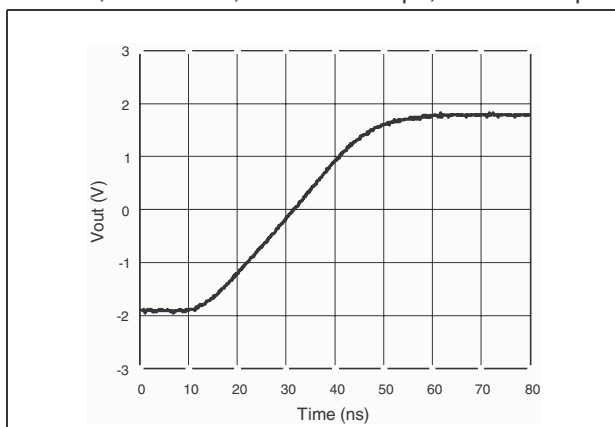
**Figure 4. Closed loop gain & phase vs. frequency**

Gain=+11,  $V_{CC} = \pm 2.5V$ ,  $R_L = 150\Omega$ ,  $T_{amb} = 25^\circ C$



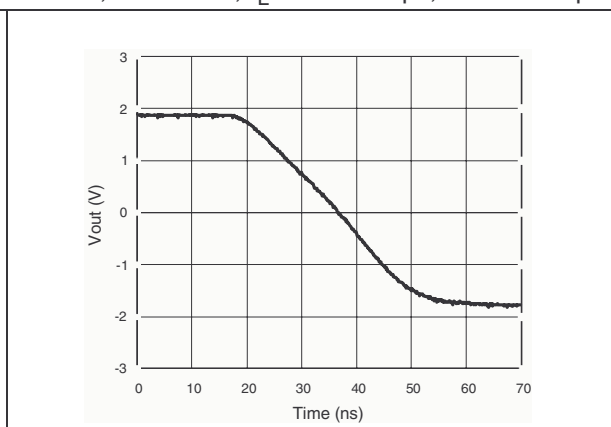
**Figure 5. Large signal measurement - positive slew rate**

Gain=2,  $V_{CC} = \pm 2.5V$ ,  $Z_L = 150\Omega // 5.6pF$ ,  $V_{in} = 400mV_{pk}$

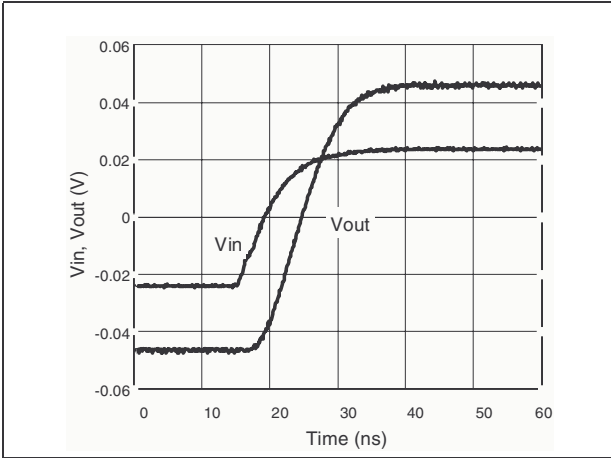


**Figure 6. Large signal measurement - negative slew rate**

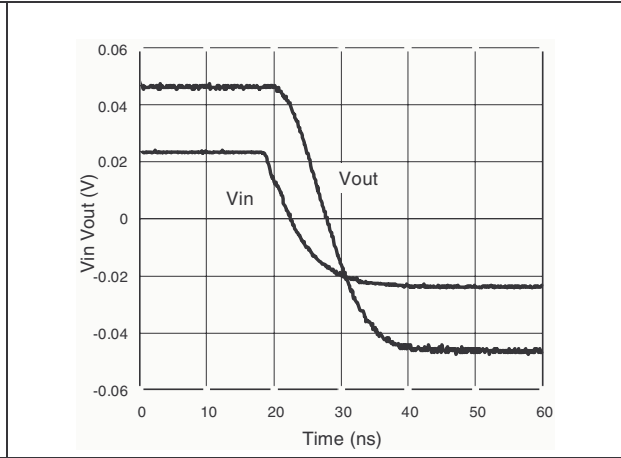
Gain=2,  $V_{CC} = \pm 2.5V$ ,  $Z_L = 150\Omega // 5.6pF$ ,  $V_{in} = 400mV_{pk}$



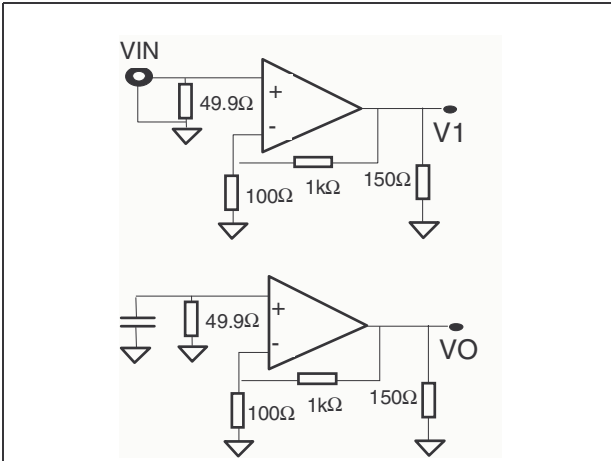
**Figure 7. Small signal measurement - rise time**  
Gain=2, Vcc=±2.5V, Zl=150Ω, Vin=400mVpk



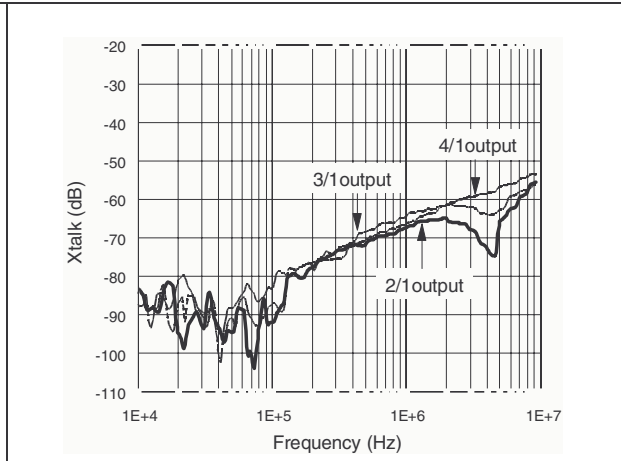
**Figure 8. Small signal measurement - fall time**  
Gain=2, Vcc=±2.5V, Zl=150Ω, Vin=400mVpk



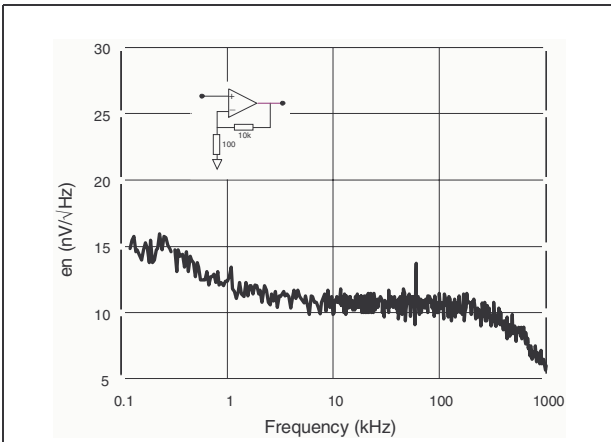
**Figure 9. Channel separation (Xtalk) vs. frequency**  
Measurement configuration:  $Xtalk = 20 \log(V0/V1)$



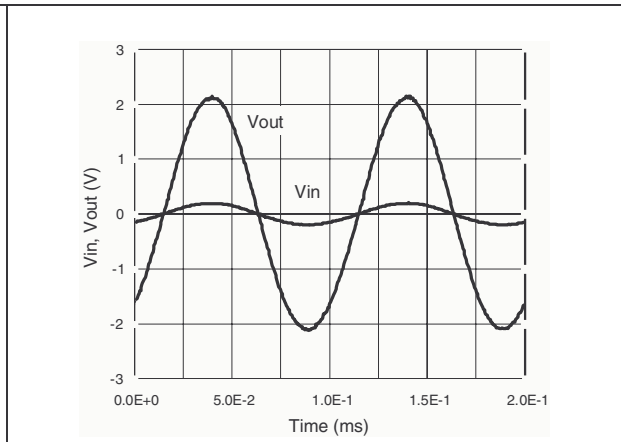
**Figure 10. Channel separation (Xtalk) vs. frequency**  
Gain=+11, Vcc=±2.5V, ZL=150Ω//27pF



**Figure 11. Equivalent noise voltage**  
Gain=100, Vcc=±2.5V, No load



**Figure 12. Maximum output swing**  
Gain=11, Vcc=±2.5V, RL=150Ω



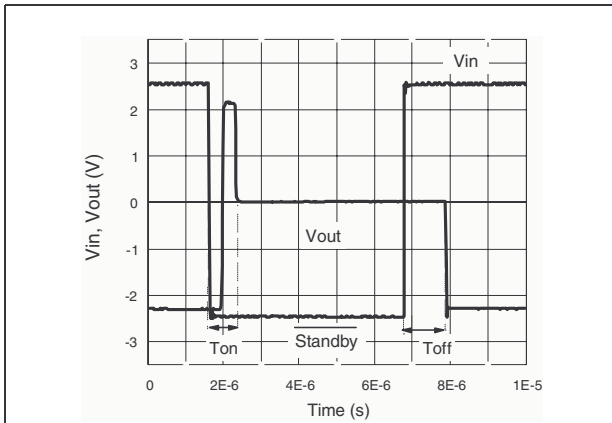
### 3 Inter Modulation Products

The IFR2026 synthesizer generates a two tones signal (F1=180kHz, F2=280kHz); each tone having the same amplitude level.

The HP3585 spectrum analyzer measures the inter modulation products function of the output voltage. The generator and the spectrum analyzer are phase locked for precision considerations.

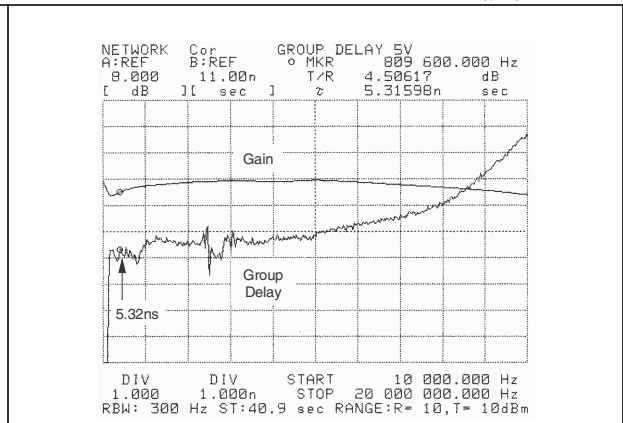
**Figure 13. Standby mode - Ton, Toff**

Vcc= ±2.5V, Open Loop



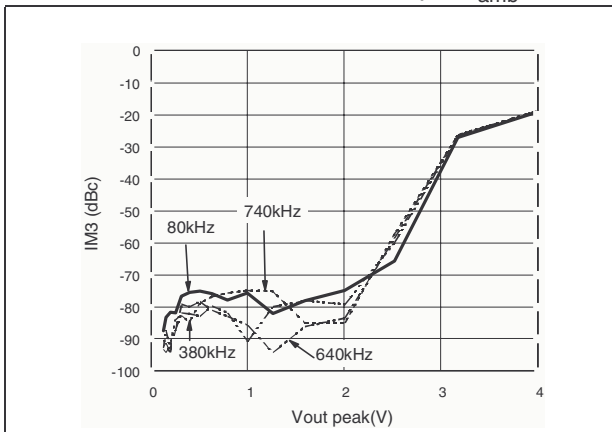
**Figure 14. Group delay**

Gain=2, Vcc= ±2.5V, ZL=150Ω//27pF, Tamb = 25°C



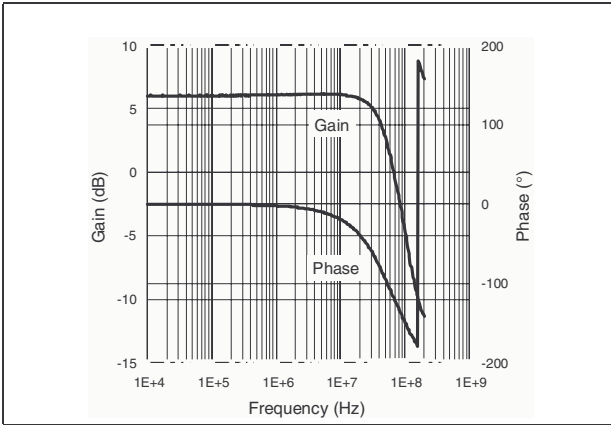
**Figure 15. Third order inter modulation**

Gain=2, Vcc= ±2.5V, ZL=150Ω//27pF, Tamb = 25°C



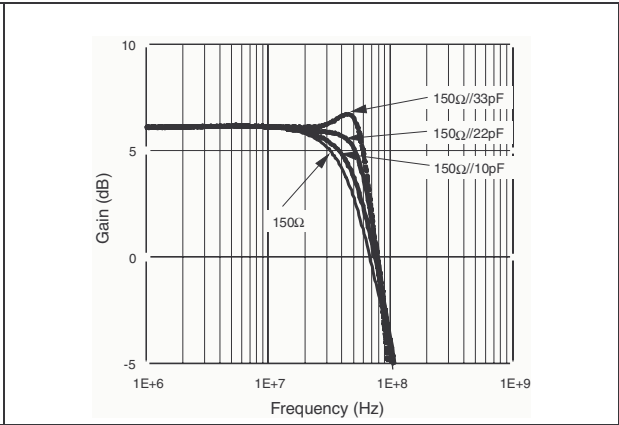
**Figure 16. Closed loop gain & phase vs. frequency**

Gain=+2,  $V_{CC} = \pm 5V$ ,  $R_L = 150\Omega$ ,  $T_{amb} = 25^\circ C$



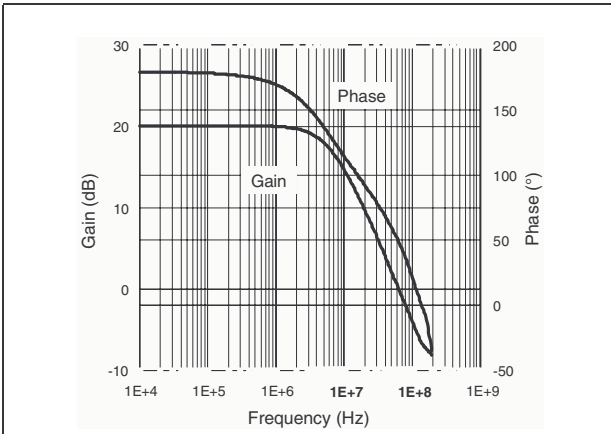
**Figure 17. Overshoot function of output capacitance**

Gain=+2,  $V_{CC} = \pm 5V$ ,  $T_{amb} = 25^\circ C$



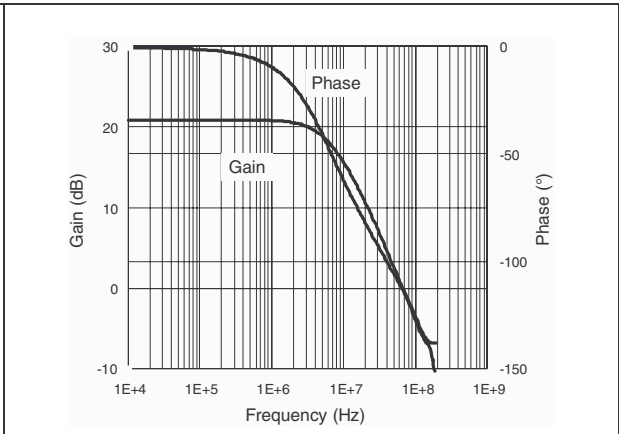
**Figure 18. Closed loop gain & phase vs. frequency**

Gain=-10,  $V_{CC} = \pm 5V$ ,  $R_L = 150\Omega$ ,  $T_{amb} = 25^\circ C$



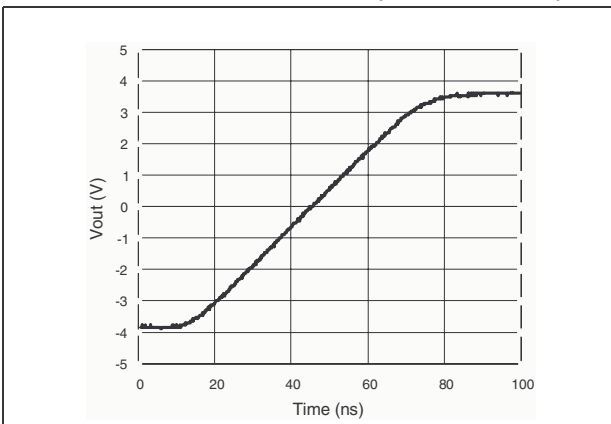
**Figure 19. Closed loop gain & phase vs. frequency**

Gain=+11,  $V_{CC} = \pm 5V$ ,  $R_L = 150\Omega$ ,  $T_{amb} = 25^\circ C$



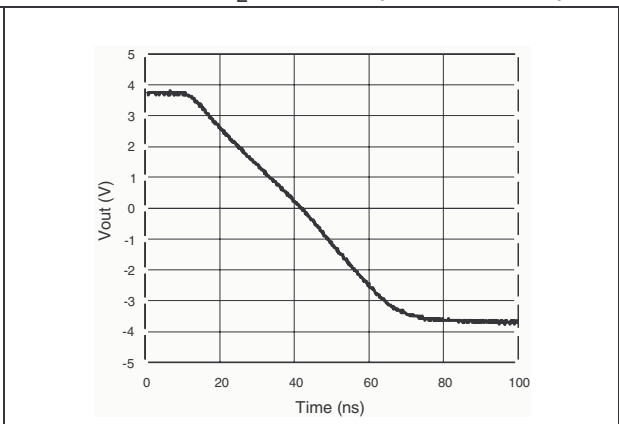
**Figure 20. Large signal measurement - positive slew rate**

Gain=2,  $V_{CC} = \pm 5V$ ,  $Z_L = 150\Omega // 5.6pF$ ,  $V_{in} = 400mV_{pk}$



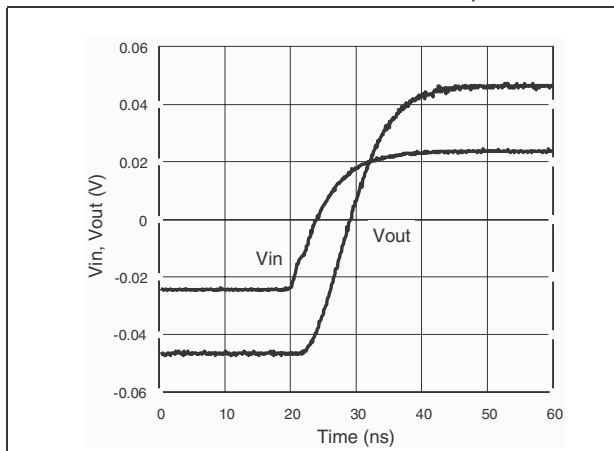
**Figure 21. Large signal measurement - negative slew rate**

Gain=2,  $V_{CC} = \pm 5V$ ,  $Z_L = 150\Omega // 5.6pF$ ,  $V_{in} = 400mV_{pk}$



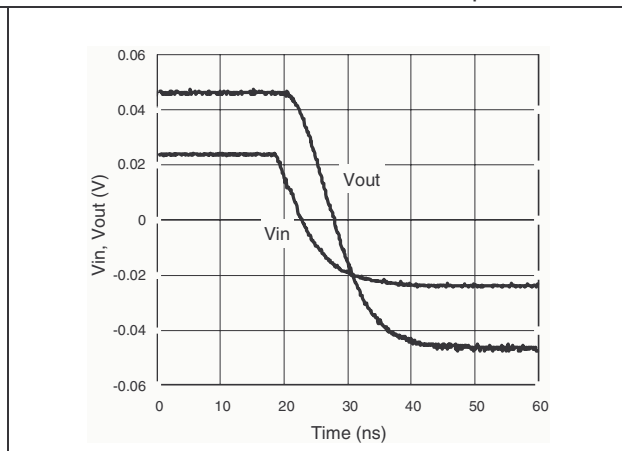
**Figure 22. Small signal measurement - rise time**

Gain=2, Vcc=±5V, Zl=150Ω, Vin=400mVpk



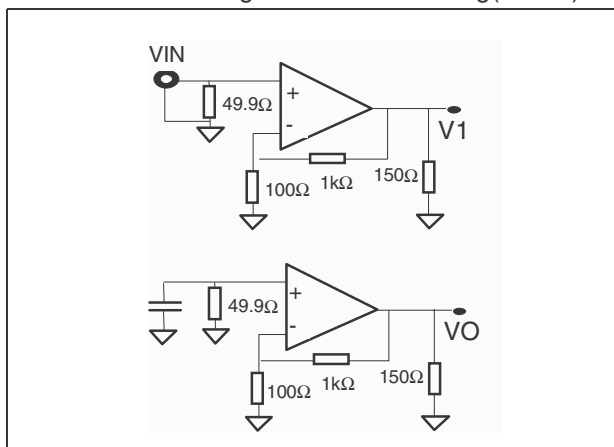
**Figure 23. Small signal measurement - fall time**

Gain=2, Vcc=±5V, Zl=150Ω, Vin=400mVpk



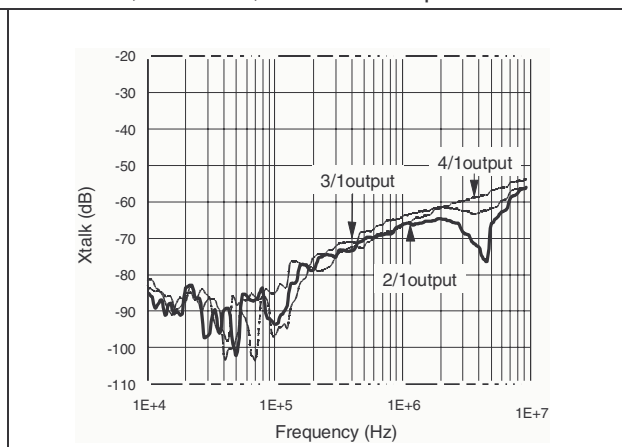
**Figure 24. Channel separation (Xtalk) vs. frequency**

Measurement configuration:  $Xtalk = 20 \log(V0/V1)$



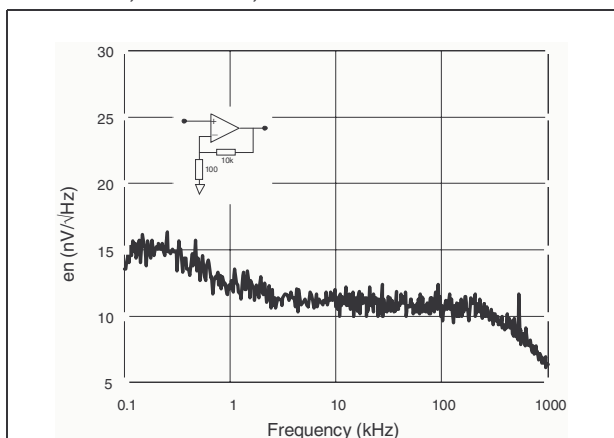
**Figure 25. Channel separation (Xtalk) vs. frequency**

Gain=+11, Vcc=±5V, ZL=150Ω//27pF



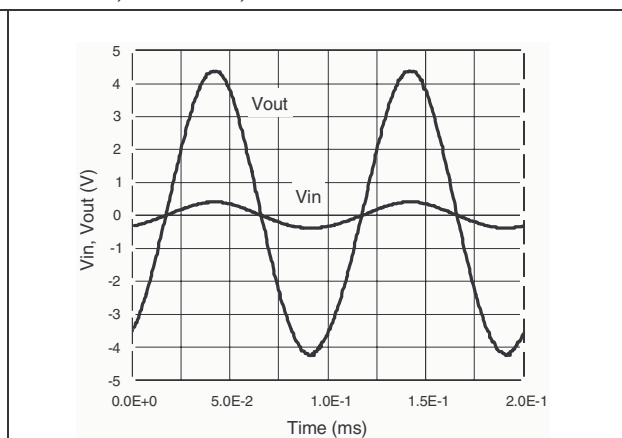
**Figure 26. Equivalent noise voltage**

Gain=100, Vcc=±5V, No load



**Figure 27. Maximum output swing**

Gain=11, Vcc=±5V, RL=150Ω

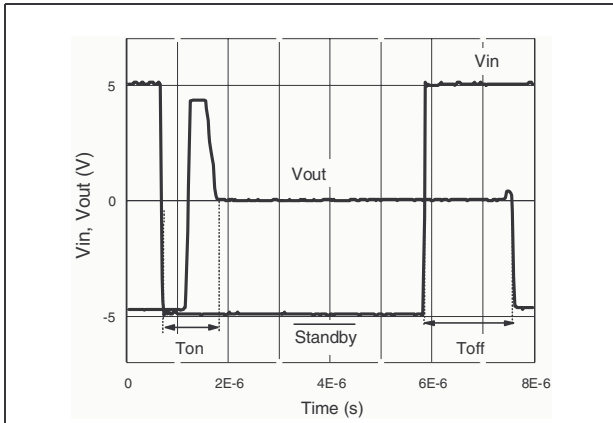


The IFR2026 synthesizer generates a two tones signal (F1=180kHz, F2=280kHz); each tone having the same amplitude level.

The HP3585 spectrum analyzer measures the inter modulation products function of the output voltage. The generator and the spectrum analyzer are phase locked for precision considerations.

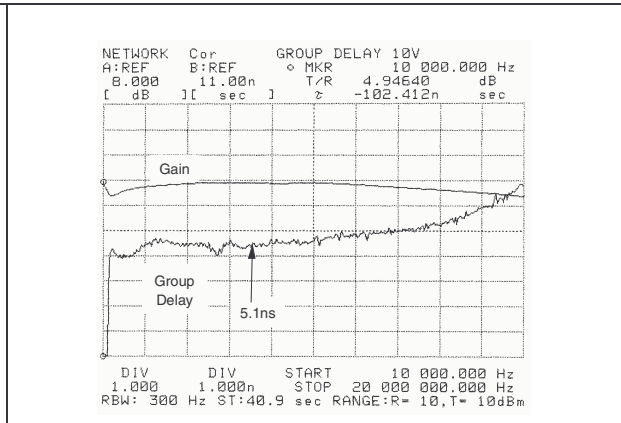
**Figure 28. Standby mode - Ton, Toff**

Vcc= ±5V, Open Loop



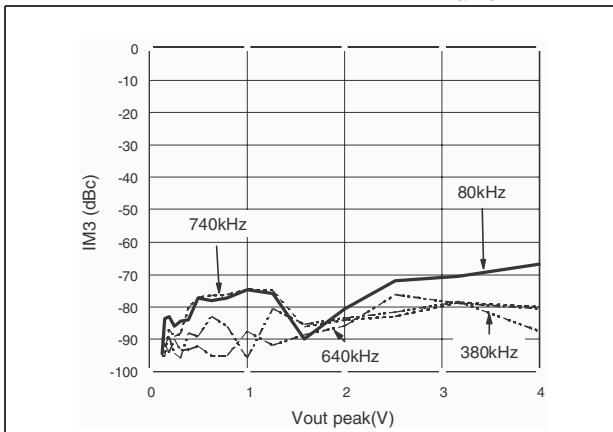
**Figure 29. Group delay**

Gain=2, Vcc= ±5V, ZL=150Ω//27pF, T<sub>amb</sub> = 25 °C



**Figure 30. Third order inter modulation**

Gain=2, Vcc= ±5V, ZL=150Ω//27pF, T<sub>amb</sub> = 25 °C



## 4 Testing Conditions

### 4.1 Layout precautions:

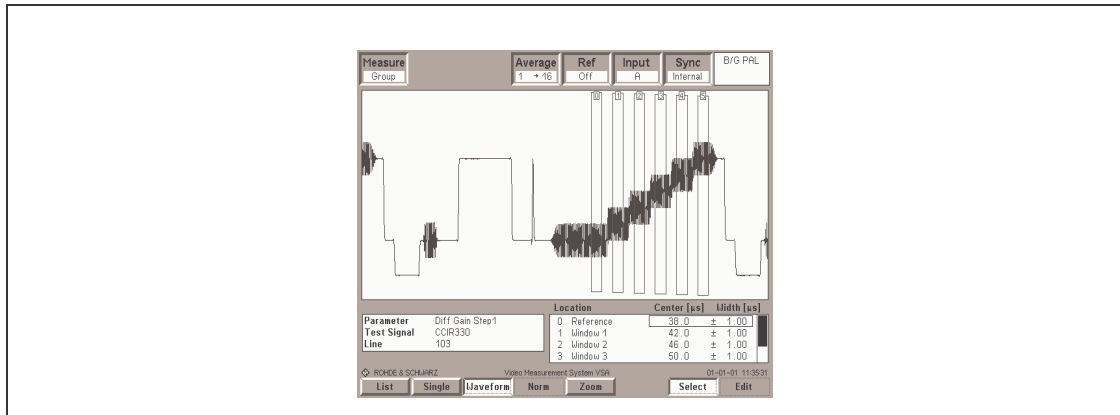
To use the TSH8X circuits in the best manner at high frequencies, some precautions have to be taken for power supplies:

- First of all, the implementation of a proper ground plane in both sides of the PCB is mandatory for high speed circuit applications to provide low inductance and low resistance common return.
- Power supply bypass capacitors (4.7uF and ceramic 100pF) should be placed as close as possible to the IC pins in order to improve high frequency bypassing and reduce harmonic distortion. The power supply capacitors must be incorporated for both the negative and the positive pins.
- Proper termination of all inputs and outputs must be in accordance with output termination resistors; then the amplifier load will be only resistive and the stability of the amplifier will be improved.

All leads must be wide and as short as possible especially for op amp inputs and outputs in order to decrease parasitic capacitance and inductance.

- For lower gain application, attention should be paid not to use large feedback resistance (>1kΩ) to reduce time constant with parasitic capacitances.
- Choose component sizes as small as possible (SMD).
- Finally, on output, the load capacitance must be negligible to maintain good stability. You can put a serial resistance the closest to the output pin to minimize its influence.

Figure 31. CCIR330 video line



### 4.2 Maximum input level:

The input level must not exceed the following values:

- Negative peak: must be greater than -Vcc+400mV.
- Positive peak value: must be lower than +Vcc-400mV.

The electrical characteristics show the influence of the load on this parameter.



### 4.3 Video capabilities:

To characterize the differential phase and differential gain a CCIR330 video line is used. The video line contains 5 (flat) levels of luma on which is superimposed chroma signal. (the first level contains no luma). The luma gives various amplitudes which define the saturation of the signal. The chrominance gives various phases which define the color of the signal. Differential phase (respectively differential gain) distortion is present if a signal chrominance phase (gain) is affected by luminance level. They represent the ability to uniformly process the high frequency information at all luminance levels. When differential gain is present, color saturation is not correctly reproduced. The input generator is the Rhode & Schwarz CCVS. The output measurement is done by the Rhode and Schwarz VSA.

Figure 32. Measurement on Rhode and Schwarz VSA

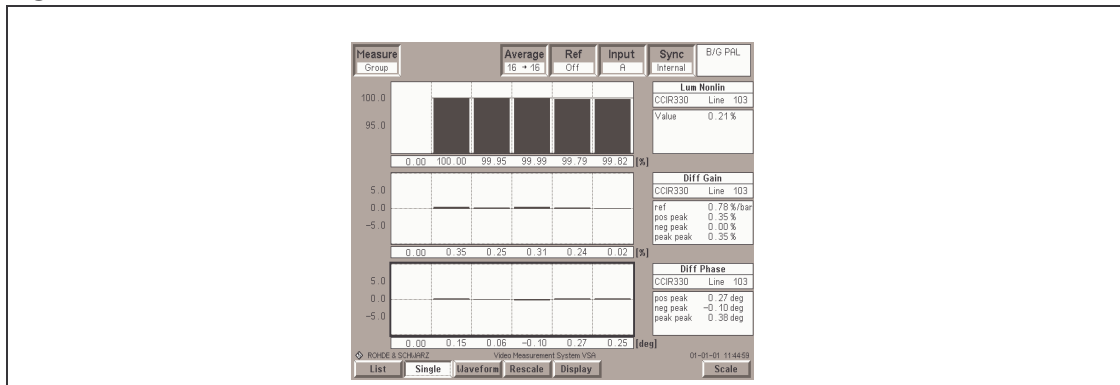


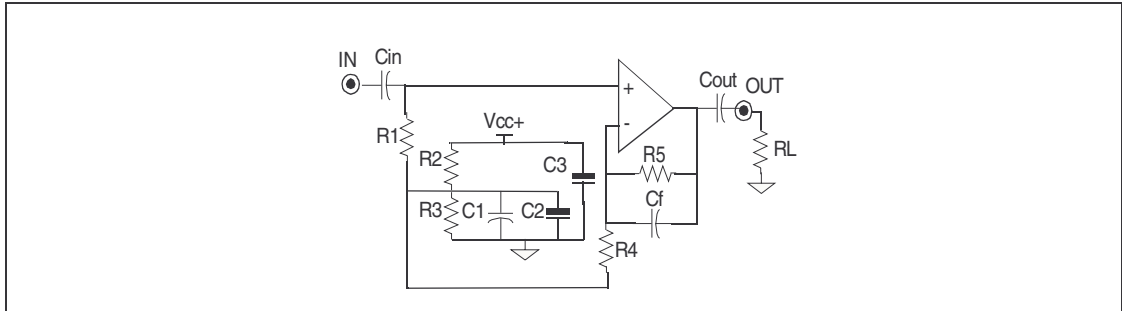
Table 6. Video results

Parameter	Value (Vcc=±2.5V)	Value (Vcc=±5V)	Unit
Lum NL	0.1	0.3	%
Lum NL Step 1	100	100	%
Lum NL Step 2	100	99.9	%
Lum NL Step 3	99.9	99.8	%
Lum NL Step 4	99.9	99.9	%
Lum NL Step 5	99.9	99.7	%
Diff Gain pos	0	0	%
Diff Gain neg	-0.7	-0.6	%
Diff Gain pp	0.7	0.6	%
Diff Gain Step1	-0.5	-0.3	%
Diff Gain Step2	-0.7	-0.6	%
Diff Gain Step3	-0.3	-0.5	%
Diff Gain Step4	-0.1	-0.3	%
Diff Gain Step5	-0.4	-0.5	%
Diff Phase pos	0	0.1	deg
Diff Phase neg	-0.2	-0.4	deg
Diff Phase pp	0.2	0.5	deg
Diff Phase Step1	-0.2	-0.4	deg
Diff Phase Step2	-0.1	-0.4	deg
Diff Phase Step3	-0.1	-0.3	deg
Diff Phase Step4	0	0.1	deg
Diff Phase Step5	-0.2	-0.1	deg

## 5 Precautions on Asymmetrical Supply Operation

The TSH8X can be used either with a dual or a single supply. If a single supply is used, the inputs are biased to the mid-supply voltage ( $+V_{cc}/2$ ). This bias network must be carefully designed, in order to reject any noise present on the supply rail.

As the bias current is 15uA, you must carefully choose the resistance R1 not to introduce an offset mismatch at the amplifier inputs.

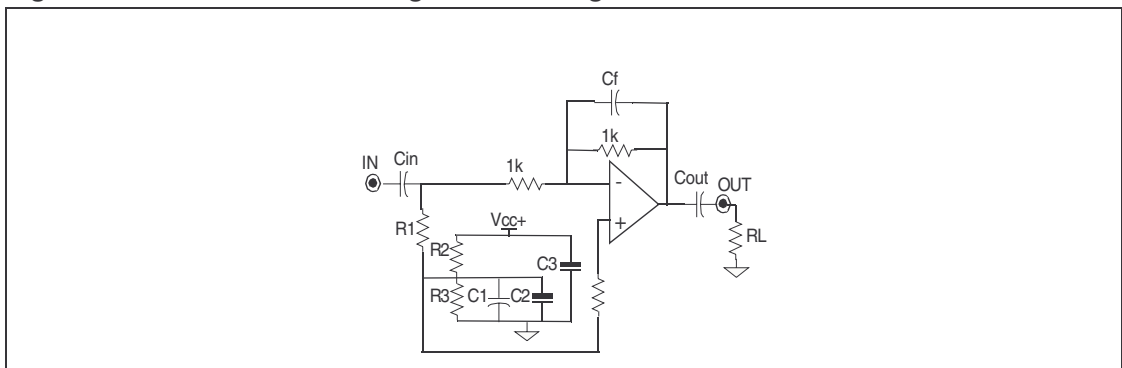


$R1=10k\Omega$  will be convenient. C1, C2, C3 are bypass capacitors from perturbation on  $V_{cc}$  as well as for the input and output signals. We choose  $C1=100nF$  and  $C2=C3=100\mu F$ .

R2, R3 are such that the current through them must be superior to 100 times the bias current. So, we take  $R2=R3=4.7k\Omega$ .

$C_{in}$ , as  $C_{out}$  are chosen to filter the DC signal by the low pass filters ( $R1, C_{in}$ ) and ( $R_{out}, C_{out}$ ). By taking  $R1=10k\Omega$ ,  $R_L=150\Omega$ , and  $C_{in}=2\mu F$ ,  $C_{out}=220\mu F$  we provide a cutoff frequency below 10Hz.

**Figure 33. Use of the TSH8x in gain = -1 configuration**



Some precautions have to be added, specially for low power supply application.

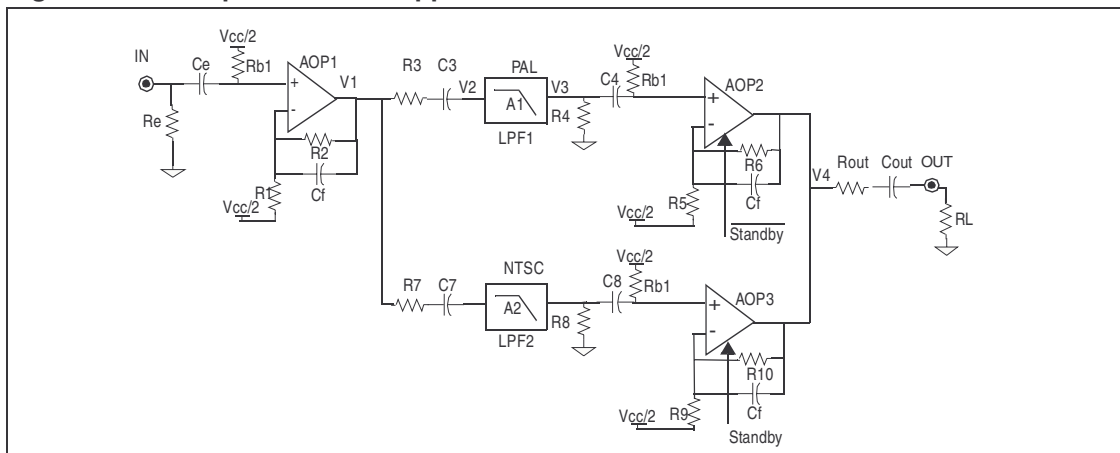
A feedback capacitance  $C_f$  should be added for better stability.

The table summarizes the impact of the capacitance  $C_f$  on the phase margin of the circuit.

**Table 7. Capacitance Cf on the phase margin of the circuit**

Parameter	Cf (pF)	Vcc=±1.5V	Vcc=±2.5V	Vcc=±5V	Unit
Phase Margin	0	28	43	56	deg
f-3dB		40	39.3	38.3	MHz
Phase Margin	5.6	30	43	56	deg
f-3dB		40	39.3	38.3	MHz
Phase Margin	22	37	52	67	deg
f-3dB		37	34	32	MHz
Phase Margin	33	48	65	78	deg
f-3dB		33.7	30.7	27.6	MHz

**Figure 34. Example of a video application**



This example shows a possible application of the TSH8X circuit. Here, you can multiplex the channels for the different standard PAL, NTSC as you filter for the different bands; the video signal can be filtered with two different cutoff frequencies, corresponding to a PAL encoded signal (LPF1) or a NTSC signal (LPF2).

You can multiplex input signals, as the outputs are in high impedance state in standby mode. This enables you, to use a PAL filter as the Standby mode is active and to use the NTSC filter otherwise.

The video application requires 1Vpeak at input and output.

Calculation of components:

A decoupling capacitor is provided to cutoff the frequencies below 10Hz according I bias. Hence Ce=10uF, with Rb1=10kΩ. At the output, Cout=220uF.

The AOP1 is in 6dB configuration for the adaptation bridge. R1=R2=1kΩ, V1=2Vpk, V2=1Vpk

For the PAL communication, we need a low pass filtering. The load resistance R4 is function of the output resistance of the filter. V3=V2/A1 where A1 is the attenuation factor of the filter LPF1.

To compensate the filter insertion loss, we add an additional factor to the gain of the 2nd amplifier AOP2.

For example, for an attenuation of 3dB, we choose R5=300Ω and R6=1kΩ. We have V4=2Vpk and Vout=1Vpk.

The calculation of the parameters R7, C7, R8, C8, R9, R10 will be exactly the same

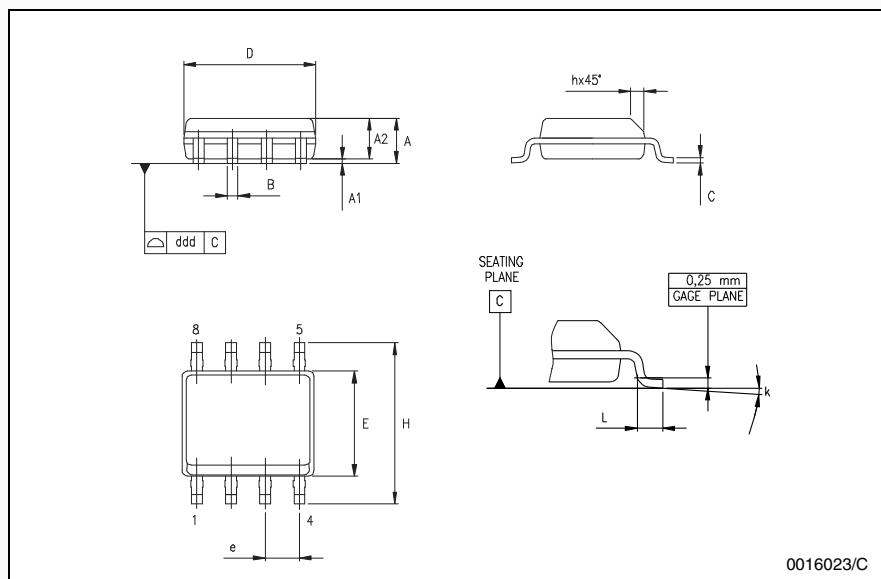
## 6 Package Mechanical Data

In order to meet environmental requirements, ST offers these devices in ECOPACK<sup>®</sup> packages. These packages have a Lead-free second level interconnect. The category of second level interconnect is marked on the package and on the inner box label, in compliance with JEDEC Standard JESD97. The maximum ratings related to soldering conditions are also marked on the inner box label. ECOPACK is an ST trademark. ECOPACK specifications are available at: [www.st.com](http://www.st.com).

### 6.1 SO-8 Package

**SO-8 MECHANICAL DATA**

DIM.	mm.			inch		
	MIN.	TYP.	MAX.	MIN.	TYP.	MAX.
A	1.35		1.75	0.053		0.069
A1	0.10		0.25	0.04		0.010
A2	1.10		1.65	0.043		0.065
B	0.33		0.51	0.013		0.020
C	0.19		0.25	0.007		0.010
D	4.80		5.00	0.189		0.197
E	3.80		4.00	0.150		0.157
e		1.27			0.050	
H	5.80		6.20	0.228		0.244
h	0.25		0.50	0.010		0.020
L	0.40		1.27	0.016		0.050
k	$8^\circ$ (max.)					
ddd			0.1			0.04

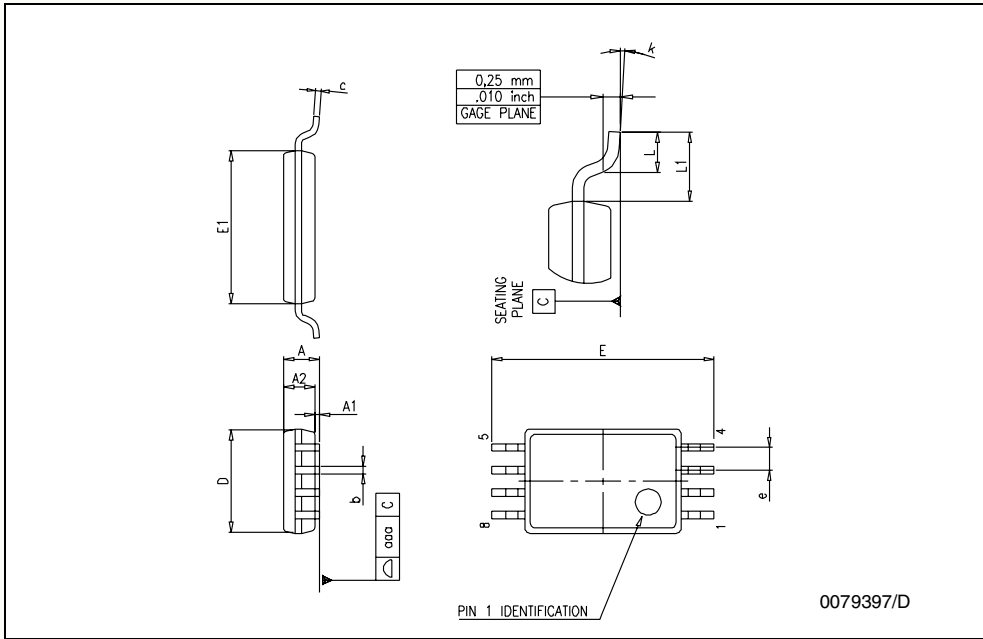


0016023/C

### 6.2 TSSOP8 Package

**TSSOP8 MECHANICAL DATA**

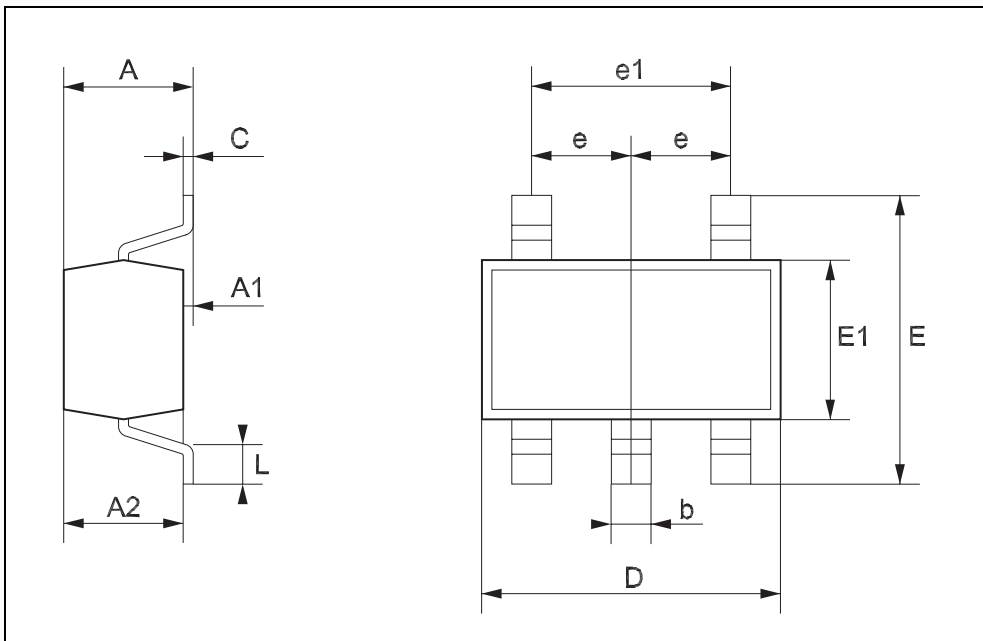
DIM.	mm.			inch		
	MIN.	TYP	MAX.	MIN.	TYP.	MAX.
A			1.2			0.047
A1	0.05		0.15	0.002		0.006
A2	0.80	1.00	1.05	0.031	0.039	0.041
b	0.19		0.30	0.007		0.012
c	0.09		0.20	0.004		0.008
D	2.90	3.00	3.10	0.114	0.118	0.122
E	6.20	6.40	6.60	0.244	0.252	0.260
E1	4.30	4.40	4.50	0.169	0.173	0.177
e		0.65			0.0256	
K	0°		8°	0°		8°
L	0.45	0.60	0.75	0.018	0.024	0.030
L1		1			0.039	



### 6.3 SOT23-5 Package

**SOT23-5L MECHANICAL DATA**

DIM.	mm.			mils		
	MIN.	TYP.	MAX.	MIN.	TYP.	MAX.
A	0.90		1.45	35.4		57.1
A1	0.00		0.15	0.0		5.9
A2	0.90		1.30	35.4		51.2
b	0.35		0.50	13.7		19.7
C	0.09		0.20	3.5		7.8
D	2.80		3.00	110.2		118.1
E	2.60		3.00	102.3		118.1
E1	1.50		1.75	59.0		68.8
e		0.95			37.4	
e1		1.9			74.8	
L	0.35		0.55	13.7		21.6



## 7 Revision History

Date	Revision	Changes
Feb. 2003	1	First Release
Aug. 2005	2	PPAP references inserted in the datasheet see <i>Table : Order Codes on page 2.</i>

Information furnished is believed to be accurate and reliable. However, STMicroelectronics assumes no responsibility for the consequences of use of such information nor for any infringement of patents or other rights of third parties which may result from its use. No license is granted by implication or otherwise under any patent or patent rights of STMicroelectronics. Specifications mentioned in this publication are subject to change without notice. This publication supersedes and replaces all information previously supplied. STMicroelectronics products are not authorized for use as critical components in life support devices or systems without express written approval of STMicroelectronics.

The ST logo is a registered trademark of STMicroelectronics.  
All other names are the property of their respective owners

© 2005 STMicroelectronics - All rights reserved

STMicroelectronics group of companies

Australia - Belgium - Brazil - Canada - China - Czech Republic - Finland - France - Germany - Hong Kong - India - Israel - Italy - Japan - Malaysia - Malta - Morocco - Singapore - Spain - Sweden - Switzerland - United Kingdom - United States of America

[www.st.com](http://www.st.com)