

Low-power, High-performance $\Delta\Sigma$ Modulator and Test DAC

Modulator Features

- Fourth-order $\Delta\Sigma$ Architecture
 - Clock-jitter-tolerant architecture
 - Input signal bandwidth: DC to 2 kHz
 - Max AC amplitude: 5 V_{pp} differential
 - Max DC amplitude: ± 2.5 V_{dc} differential
- High Dynamic Range
 - 127 dB SNR @ 215 Hz BW (2 ms sampling)
 - 124 dB SNR @ 430 Hz BW (1 ms sampling)
- Low Total Harmonic Distortion
 - -118 dB THD typical (0.000126%)
 - -112 dB THD maximum (0.000251%)
- Low Power Consumption: 25 mW, 10 μ W

Test DAC Features

- Digital $\Delta\Sigma$ Input from CS5378 Digital Filter
- Selectable Differential Analog Outputs
 - Precision output (OUT \pm) for electronics tests
 - Buffered output (BUF \pm) for sensor tests
- Multiple AC and DC Operational Modes
 - Output signal bandwidth: DC to 100 Hz
 - Max AC amplitude: 5 V_{pp} differential
 - Max DC amplitude: + 2.5 V_{dc} differential
- Selectable Attenuation for CS3301A / CS3302A
 - 1, 1/2, 1/4, 1/8, 1/16, 1/32, 1/64
- Outstanding Performance
 - AC (OUT): -116 dB THD typical, -112 dB max
 - AC (BUF): -108 dB THD typical, -90 dB max
 - DC absolute accuracy: 0.4% typical, 1% max
- Low Power Consumption
 - AC modes / DC modes: 40 mW / 20 mW
 - Sleep mode / Power down: 1 mW / 10 μ W

Common Features

- Extremely Small Footprint
 - 28-pin SSOP package, 8 mm x 10 mm
- Bipolar Power Supply Configuration
 - VA+ = +2.5 V; VA- = -2.5 V; VD = +3.3 V

Description

The CS5373A is a high-performance, fourth-order $\Delta\Sigma$ modulator integrated with a $\Delta\Sigma$ digital-to-analog converter (DAC). When combined with a CS3301A / CS3302A differential amplifier and the CS5378 digital filter, a small, low-power, self-testing, high-accuracy, single-channel measurement system results.

The modulator has high dynamic range and low total harmonic distortion with very low power consumption. It converts differential analog input signals from the CS3301A / CS3302A amplifier to an oversampled serial bit stream at 512 kbits per second. This oversampled bit stream is then decimated by the CS5378 digital filter to a 24-bit output at the selected output word rate.

The test DAC operates in either AC or DC test modes. AC test modes measure system dynamic performance through THD and CMRR tests while DC test modes are for gain calibration and pulse tests. It has two sets of differential analog outputs, *OUT* and *BUF*, as dedicated outputs for testing the electronics channel and for in-circuit sensor tests. Output attenuation settings are binary weighted and match the gain settings of the CS3301A / CS3302A differential amplifiers for full-scale testing at all gain ranges.

ORDERING INFORMATION

See [page 39](#).

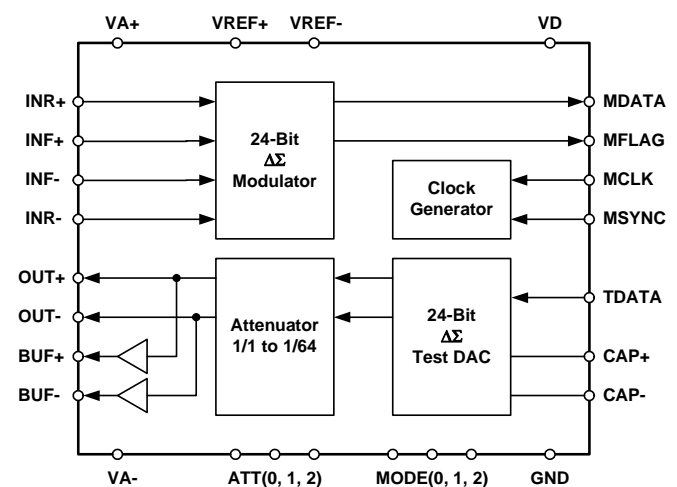

TABLE OF CONTENTS

1. CHARACTERISTICS AND SPECIFICATIONS	4
SPECIFIED OPERATING CONDITIONS	4
TEMPERATURE CONDITIONS	5
ABSOLUTE MAXIMUM RATINGS	5
ANALOG INPUT CHARACTERISTICS	6
ANALOG OUTPUT CHARACTERISTICS	7
MODULATOR CHARACTERISTICS	8
PERFORMANCE PLOTS	9
DAC AC DIFFERENTIAL MODES 1, 2, 3	10
DIGITAL CHARACTERISTICS	15
POWER SUPPLY CHARACTERISTICS	18
2. GENERAL DESCRIPTION	19
2.1 Delta-Sigma Modulator	19
2.2 Digital-to-Analog Converter	19
3. SYSTEM DIAGRAM	20
4. POWER MODES	21
4.1 Power Down	21
4.2 Sleep Mode	21
4.3 Modulator Mode	21
4.4 AC Test Modes	21
4.5 DC Test Modes	21
5. OPERATIONAL MODES	22
5.1 Modulator Mode	22
5.1.1 Modulator One's Density	22
5.1.2 Modulator Decimated Output	22
5.1.3 Modulator Synchronization	22
5.1.4 Modulator Idle Tones	23
5.1.5 Modulator Stability	23
5.2 AC Test Modes	23
5.2.1 AC Differential	23
5.2.2 AC Common Mode	24
5.2.3 DAC Stability	24
5.3 DC Test Modes	24
5.3.1 DC Common Mode	24
5.3.2 DC Differential	25
5.4 Sleep Mode	25
6. DIGITAL SIGNALS	26
6.1 MCLK Connection	26
6.2 MSYNC Connection	26
6.3 MDATA Connection	27
6.4 MFLAG Connection	27
6.5 TDATA Connection	27
6.6 GPIO Connections	27
7. ANALOG SIGNALS	28
7.1 IN _R ±, INF _± Modulator Inputs	28
7.1.1 Modulator Input Impedance	28
7.1.2 Modulator Anti-alias Filter	28
7.2 DAC Output Attenuation	29
7.3 DAC OUT _± Precision Output	29
7.4 DAC BUF _± Buffered Output	30
7.5 DAC CAP _± Connection	30
7.6 Analog Differential Signals	30
8. VOLTAGE REFERENCE	31

8.1 VREF Power Supply	31
8.2 VREF RC Filter	31
8.3 VREF PCB Routing	31
8.4 VREF Input Impedance	31
8.5 VREF Accuracy	32
8.6 VREF Independence	32
9. POWER SUPPLIES	33
9.1 Power Supply Bypassing	33
9.2 PCB Layers and Routing	33
9.3 Power Supply Rejection	33
9.4 SCR Latch-up	34
9.5 DC-DC Converters	34
10. TERMINOLOGY	35
11. PIN DESCRIPTION	36
12. PACKAGE DIMENSIONS	38
13. ORDERING INFORMATION	39
14. ENVIRONMENTAL, MANUFACTURING, & HANDLING INFORMATION	39
15. REVISION HISTORY	40

LIST OF FIGURES

Figure 1. Modulator Noise Performance	9
Figure 2. Modulator + Test DAC Dynamic Performance.....	9
Figure 3. Digital Input Rise and Fall Times	15
Figure 4. System Timing Diagram.....	17
Figure 5. MCLK / MSYNC Timing Detail	17
Figure 6. CS5373A Block Diagram	19
Figure 8. Connection Diagram	20
Figure 7. System Diagram	20
Figure 9. Power Mode Diagram	21
Figure 10. AC Differential Modes	23
Figure 11. AC Common Mode	24
Figure 12. DC Test Modes	25
Figure 13. Digital Signals	26
Figure 14. Analog Signals	28
Figure 15. DAC Output Attenuation Settings	29
Figure 16. Voltage Reference Circuit	31
Figure 17. Power Supply Diagram	33

LIST OF TABLES

Table 1. Selections for Operational Mode and DAC Attenuation	4
Table 2. Operational Modes.....	22
Table 3. Output Coding for the CS5373A Modulator and CS5378 Digital Filter Combination	22

1. CHARACTERISTICS AND SPECIFICATIONS

- Min / Max characteristics and specifications are guaranteed over the *Specified Operating Conditions*.
- Typical performance characteristics and specifications are measured at nominal supply voltages and $T_A = 25^\circ\text{C}$.
- GND = 0 V. Single-ended voltages with respect to GND, differential voltages with respect to opposite half.
- Device is connected as shown in [Figure 8 on page 20](#) unless otherwise noted.

SPECIFIED OPERATING CONDITIONS

Parameter		Symbol	Min	Nom	Max	Unit
Bipolar Power Supplies						
Positive Analog	$\pm 2\%$	VA+	2.45	2.50	2.55	V
Negative Analog	(Note 1) $\pm 2\%$	VA-	-2.45	-2.50	-2.55	V
Positive Digital	$\pm 3\%$	VD	3.20	3.30	3.40	V
Voltage Reference						
{VREF+} - {VREF-}	(Note 2, 3)	VREF	-	2.500	-	V
VREF-	(Note 4)	VREF-	-	VA -	-	V
Thermal						
Ambient Operating Temperature	Industrial (-ISZ)	T_A	-40	25	85	$^\circ\text{C}$

- Notes:
1. VA- must always be the most-negative input voltage to avoid potential SCR latch-up conditions.
 2. By design, a 2.500 V voltage reference input results in the best signal-to-noise performance.
 3. Full-scale accuracy is directly proportional to the voltage reference absolute accuracy.
 4. VREF inputs must satisfy: $VA- \leq VREF- < VREF+ \leq VA+$.

Modes of Operation		
Selection	MODE [2:0]	Mode Description
0	0 0 0	Modulator: enabled. DAC: sleep.
1	0 0 1	Modulator: enabled. DAC: AC OUT and BUF outputs.
2	0 1 0	Modulator: enabled. DAC: AC OUT only, BUF high-z.
3	0 1 1	Modulator: enabled. DAC: AC BUF only, OUT high-z.
4	1 0 0	Modulator: enabled. DAC: DC common mode output.
5	1 0 1	Modulator: enabled. DAC: DC differential output.
6	1 1 0	Modulator: enabled. DAC: AC common mode output.
7	1 1 1	Modulator: sleep. DAC: sleep.

DAC Attenuation			
Selection	ATT[2:0]	Attenuation	dB
0	0 0 0	1/1	0 dB
1	0 0 1	1/2	-6.02 dB
2	0 1 0	1/4	-12.04 dB
3	0 1 1	1/8	-18.06 dB
4	1 0 0	1/16	-24.08 dB
5	1 0 1	1/32	-30.10 dB
6	1 1 0	1/64	-36.12 dB
7	1 1 1	reserved	reserved

Table 1. Selections for Operational Mode and DAC Attenuation

TEMPERATURE CONDITIONS

Parameter	Symbol	Min	Typ	Max	Unit
Ambient Operating Temperature	T_A	-40	-	85	°C
Storage Temperature Range	T_{STR}	-65	-	150	°C
Allowable Junction Temperature	T_{JCT}	-	-	125	°C
Junction to Ambient Thermal Impedance (4-layer PCB)	Θ_{JA}	-	65	-	°C / W

ABSOLUTE MAXIMUM RATINGS

Parameter	Symbol	Min	Max	Parameter
DC Power Supplies	Positive Analog VA+	-0.5	6.8	V
	Negative Analog VA-	-6.8	0.5	V
	Digital VD	-0.5	6.8	V
Analog Supply Differential (VA+) - (VA-)	V_{A_DIFF}	-	6.8	V
Digital Supply Differential (VD) - (VA-)	V_{D_DIFF}	-	7.6	V
Input Current, Power Supplies (Note 5)	I_{PWR}	-	±50	mA
Input Current, Any Pin Except Supplies (Note 5, 6)	I_{IN}	-	±10	mA
Output Current (Note 5)	I_{OUT}	-	±25	mA
Power Dissipation	PDN	-	500	mW
Analog Input Voltages	V_{INA}	(VA-) - 0.5	(VA+) + 0.5	V
Digital Input Voltages	V_{IND}	-0.5	(VD) + 0.5	V

WARNING: Operation at or beyond these limits may result in permanent damage to the device.
Normal operation is not guaranteed at these extremes.

Notes: 5. Transient currents up to ±100 mA will not cause SCR latch-up.

6. Includes continuous over-voltage conditions at the modulator analog input pins.

ANALOG INPUT CHARACTERISTICS

Parameter	Symbol	Min	Typ	Max	Unit	
VREF Input						
{VREF+} - {VREF-} (Note 2, 3)	VREF	-	2.500	-	V	
VREF- (Note 4)	VREF-	-	VA -	-	V	
VREF Input Current, Modulator Only	VREF _{IMOD}	-	120	-	μA	
VREF Input Current, Modulator + DAC AC Mode	VREF _{IMAC}	-	200	-	μA	
VREF Input Current, Modulator + DAC DC Mode	VREF _{IMDC}	-	160	-	μA	
VREF Input Noise (Note 7)	VREF _{IN}	-	-	1	μV _{rms}	
Modulator IN_{R±}, INF_± Inputs						
External Anti-alias Filter (Note 8)	Series Resistance	R _{AA}	-	680	-	Ω
	Differential Capacitance	C _{AA}	-	20	-	nF
Differential Input Impedance	IN _{R±}	ZDIF _{INR}	-	20	-	kΩ
	INF _±	ZDIF _{INF}	-	1	-	MΩ
Single-ended Input Impedance	IN _{R±}	ZSE _{INR}	-	40	-	kΩ
	INF _±	ZSE _{INF}	-	2	-	MΩ
DAC CAP_± Input						
External Anti-alias Filter (Note 8)	Differential Capacitance	C _{AA}	-	10	-	nF

- Notes:
- Maximum integrated noise over the measurement bandwidth for the voltage reference device attached to the VREF_± inputs.
 - Differential anti-alias capacitors are discrete external components and must be of good quality (C0G, NPO, poly). Poor quality capacitors will degrade total harmonic distortion (THD) performance.

ANALOG OUTPUT CHARACTERISTICS

Parameter		Symbol	Min	Typ	Max	Unit
DAC Analog OUT\pm Output						
Analog External Load at OUT \pm (Note 9, 10)	Load Resistance	R _{LOUT}	50	-	-	M Ω
	Load Capacitance	C _{LOUT}	-	-	50	pF
Differential Output Impedance	1/1	ZDIF _{OUT}	-	1.4	-	k Ω
	1/2		-	10.1	-	k Ω
	1/4		-	7.9	-	k Ω
	1/8		-	5.1	-	k Ω
	1/16		-	3.3	-	k Ω
	1/32		-	2.3	-	k Ω
	1/64		-	1.7	-	k Ω
Single-ended Output Impedance	1/1	ZSE _{OUT}	-	0.8	-	k Ω
	1/2		-	7.4	-	k Ω
	1/4		-	9.0	-	k Ω
	1/8		-	9.4	-	k Ω
	1/16		-	9.5	-	k Ω
	1/32		-	9.5	-	k Ω
	1/64		-	9.2	-	k Ω
High-Z Impedance	(Note 9)	HZ _{OUT}	-	3	-	M Ω
Crosstalk to BUF \pm High-Z Output	(Note 9)	XT _{OUT}	-	-120	-	dB
DAC Analog BUF\pm Output						
Analog External Load at BUF \pm (Note 9)	Load Resistance	R _{LBUF}	1	-	-	k Ω
	Load Capacitance	C _{LBUF}	-	-	2	nF
Differential Output Impedance	1/1 - 1/64	ZDIF _{BUF}	-	6	-	Ω
Single-ended Output Impedance	1/1 - 1/32	ZSE _{BUF}	-	3	-	Ω
	(Note 11) (BUF-) 1/64		-	3	-	
	(Note 11) (BUF+) 1/64		-	50	-	
High-Z Impedance	(Note 9)	HZ _{BUF}	-	4.5	-	M Ω
Crosstalk to OUT \pm High-Z Output	(Note 9)	XT _{BUF}	-	-120	-	dB

Notes: 9. Guaranteed by design and/or characterization.

10. Load on the precision OUT \pm outputs is normally from a CS3301A / CS3302A amplifier, which has 1 G Ω /1 T Ω typical input impedance and 18 pF typical input capacitance.

11. Single-ended output impedance at 1/64 is different for BUF+ and BUF- due to the output attenuator architecture.

MODULATOR CHARACTERISTICS

Parameter	Symbol	Min	Typ	Max	Unit	
Input Characteristics						
Input Signal Frequencies (Note 9, 12)	V_{BW}	DC	-	2000	Hz	
Full Scale Differential AC Input (Note 9)	V_{AC}	-	-	5	V_{pp}	
Full Scale Differential DC Input (Note 9)	V_{DC}	-2.5	-	2.5	V_{dc}	
Input Common Mode Voltage (Note 13)	V_{CM}	-	(VA-)+2.5	-	V	
Input Voltage Range (Signal $\pm V_{cm}$) (Note 9)	V_{RNG}	(VA-)+0.7	-	(VA+)-1.25	V	
Dynamic Performance						
Dynamic Range (Note 12, 14)	SNR	(1/4 ms) DC to 1720 Hz	-	109	-	dB
		(1/2 ms) DC to 860 Hz	-	121	-	dB
		(1 ms) DC to 430 Hz	121	124	-	dB
		(2 ms) DC to 215 Hz	-	127	-	dB
		(4 ms) DC to 108 Hz	-	130	-	dB
		(8 ms) DC to 54 Hz	-	133	-	dB
		(16 ms) DC to 27 Hz	-	136	-	dB
Signal Dependent Noise (Note 15, 16)	SDN	100	110	-	dB	
Total Harmonic Distortion (Note 16)	THD	-	-118	-112	dB	
Linearity (Note 16)	LIN	-	0.000126	0.000251	%	
Common Mode Rejection Ratio	CMRR	-	110	-	dB	
Gain Accuracy						
Channel to Channel Gain Accuracy (Note 3)	GA	-	± 1	± 2	%	
Channel Gain Drift (Note 17)	GA_{TC}	-	22	-	ppm/ $^{\circ}C$	
Offset						
Offset Voltage, Differential	OFST	-	+100	-	mV	
Offset after Calibration (Note 18)	$OFST_{CAL}$	-	± 1	-	μV	
Offset Calibration Range (Note 19)	$OFST_{RNG}$	-	100	-	%FS	
Offset Voltage Drift (Note 17)	$OFST_{TC}$	-	300	-	nV/ $^{\circ}C$	

- Notes: 12. The upper bandwidth limit is determined by the CS5378 digital filter cut-off frequency.
13. Common mode voltage is defined as the mid-point of the differential signal.
14. Dynamic Range defined as $20 \log [(RMS \text{ full scale}) / (RMS \text{ idle noise})]$ where idle noise is measured from a CS3301A / CS3302A amplifier terminated input at 1x gain.
15. Signal-dependent Noise defined as $20 \log [(RMS \text{ full scale}) / (RMS \text{ signal noise})]$ where signal noise is measured by subtracting out the signal power at the fundamental and harmonic frequencies.
16. Tested with a 31.25 Hz sine wave at -1 dB amplitude.
17. Specification is for the parameter over the specified temperature range and is for the device only. It does not include the effects of external components.
18. Specification applies to the effective offset voltage calculated from the output codes of the CS5378 digital filter following offset calibration and correction.
19. Offset calibration is performed in the CS5378 digital filter and includes the full-scale signal range.

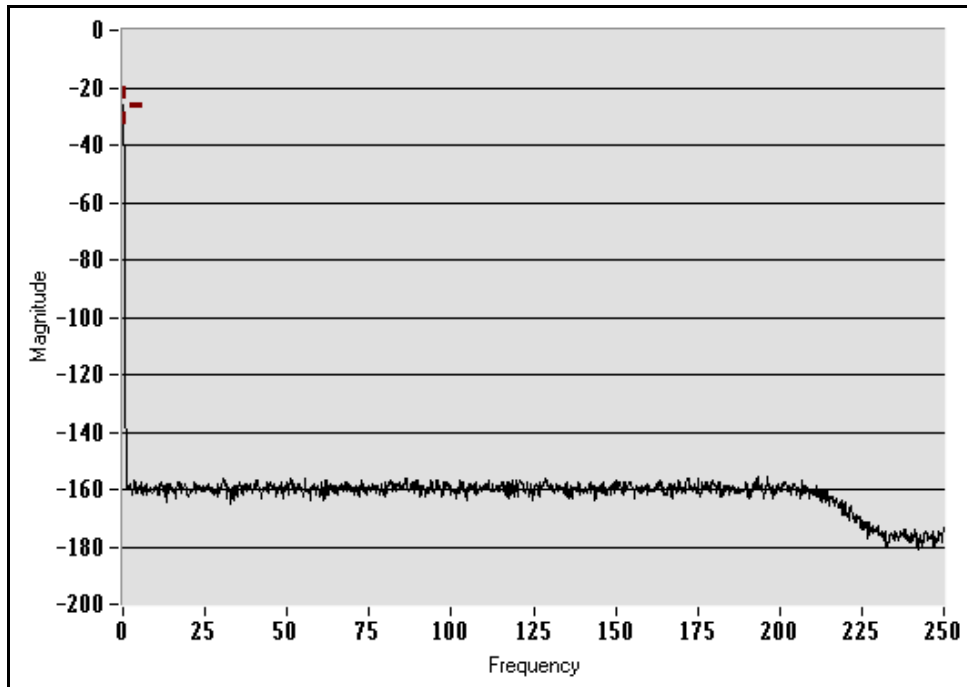
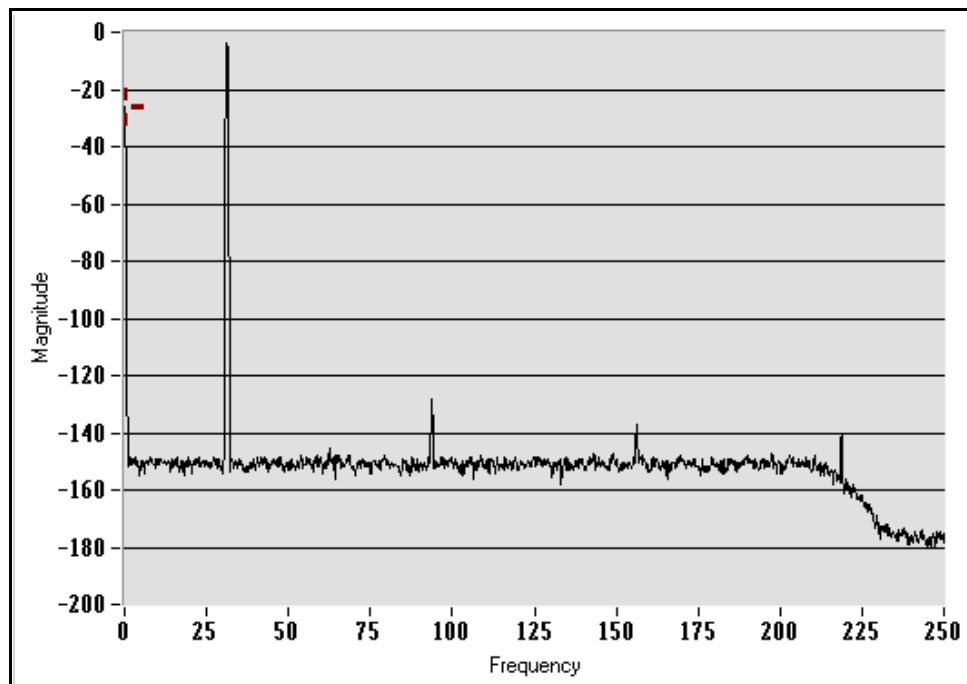
PERFORMANCE PLOTS**Figure 1. Modulator Noise Performance****Figure 2. Modulator + Test DAC Dynamic Performance**

DAC AC DIFFERENTIAL MODES 1, 2, 3

Parameter		Symbol	Min	Typ	Max	Unit
AC Differential Characteristics						
Full-scale Differential AC Output	1/1	VAC _{FS}	-	5	-	V _{pp}
	1/2		-	2.5	-	V _{pp}
	1/4		-	1.25	-	V _{pp}
	1/8		-	625	-	mV _{pp}
	1/16		-	312.5	-	mV _{pp}
	1/32		-	156.25	-	mV _{pp}
	1/64		-	78.125	-	mV _{pp}
Full-scale Bandwidth	(Note 9)	VAC _{BW}	-	-	100	Hz
Impulse Amplitude	(Note 9, 20)	VAC _{IMP}	-	-	-20	dBfs
AC Differential Accuracy						
Full-scale Accuracy (Note 3, 21)	1/1	VAC _{ABS}	- 0.5	- 0.2	0.2	%FS
Relative Accuracy (Note 22)	1/2	VAC _{REL}	- 0.2	± 0.1	0.2	%
	1/4		-	± 0.1	-	%
	1/8		-	± 0.1	-	%
	1/16		-	-0.1 ± 0.2	-	%
	1/32		-	-0.2 ± 0.3	-	%
	1/64		-	-0.5 ± 0.5	-	%
Full-scale Drift	(Note 17)	VAC _{TC}	-	25	-	μV/°C
DC Common Mode Characteristics						
Common Mode	(Note 13)	VAC _{CM}	-	(VA-)+2.35	-	V
Common Mode Drift	(Note 13, 17)	VAC _{CMTC}	-	300	-	μV/°C

Notes: 20. Maximum amplitude for DAC operation above 100 Hz. A reduced amplitude for higher frequencies is required to guarantee stability of the low-power $\Delta\Sigma$ DAC architecture.

21. Full-scale accuracy compares the defined full-scale 1/1 amplitude to the measured 1/1 amplitude. Specification is for unloaded outputs. Applying a differential load lowers the output amplitude ratiometric to the differential output impedance.
22. Relative accuracy compares the measured 1/2, 1/4, 1/8, 1/16, 1/32, 1/64 amplitude to the measured 1/1 amplitude.

DAC AC DIFFERENTIAL MODES 1, 2, 3 (CONT.)

Parameter	Symbol	Min	Typ	Max	Unit	
Signal to Noise						
Signal to Noise (OUT± Unloaded) (Note 23)	1/1 -> 1x	SNR _{OUT}	-	114	-	dB
	1/2 -> 2x		-	114	-	dB
	1/4 -> 4x		-	114	-	dB
	1/8 -> 8x		-	113	-	dB
	1/16 -> 16x		-	111	-	dB
	1/32 -> 32x		-	108	-	dB
	1/64 -> 64x		-	103	-	dB
Signal to Noise (BUF± Unloaded, 1 kΩ load) (Note 23, 24)	1/1 -> 1x	SNR _{BUF}	-	110	-	dB
	1/2 -> 2x		-	106	-	dB
	1/4 -> 4x		-	101	-	dB
	1/8 -> 8x		-	95	-	dB
	1/16 -> 16x		-	89	-	dB
	1/32 -> 32x		-	83	-	dB
	1/64 -> 64x		-	77	-	dB
Total Harmonic Distortion						
Total Harmonic Distortion (OUT± Unloaded) (Note 16, 25)	1/1 -> 1x	THD _{OUT}	-	-116	-112	dB
	1/2 -> 2x		-	-115	-	dB
	1/4 -> 4x		-	-114	-	dB
	1/8 -> 8x		-	-112	-	dB
	1/16 -> 16x		-	-111	-	dB
	1/32 -> 32x		-	-110	-	dB
	1/64 -> 64x		-	-106	-	dB
Total Harmonic Distortion (BUF± Unloaded) (Note 16, 24, 25)	1/1 -> 1x	THD _{BUF}	-	-108	-90	dB
	1/2 -> 2x		-	-105	-	dB
	1/4 -> 4x		-	-100	-	dB
	1/8 -> 8x		-	-94	-	dB
	1/16 -> 16x		-	-88	-	dB
	1/32 -> 32x		-	-82	-	dB
	1/64 -> 64x		-	-76	-	dB
Total Harmonic Distortion (BUF± 1 kΩ load) (Note 16, 24, 25)	1/1 -> 1x	THD _{BUFL}	-	-102	-80	dB
	1/2 -> 2x		-	-101	-	dB
	1/4 -> 4x		-	-97	-	dB
	1/8 -> 8x		-	-92	-	dB
	1/16 -> 16x		-	-87	-	dB
	1/32 -> 32x		-	-82	-	dB
	1/64 -> 64x		-	-76	-	dB

Notes: 23. Specification measured using CS3301A amplifier at corresponding gain with the modulator measuring a 430 Hz bandwidth. Amplified noise dominates for x16, x32, x64 amplifier gains.

24. Buffered outputs (BUF±) include 1/f noise not present on the precision outputs (OUT±).

25. Specification measured using CS3301A amplifier at corresponding gain with the modulator measuring a 430 Hz bandwidth. Amplified noise in the harmonic bins dominates THD measurements for x16, x32, x64 amplifier gains.

DAC DC COMMON MODE 4

Parameter	Symbol	Min	Typ	Max	Unit	
DC Common Mode Characteristics						
Common Mode Output	VDC _{CM}	-	(VA-)+2.35	-	V	
Common Mode Drift (Note 17)	VDC _{CMTC}	-	300	-	μV/°C	
DC Common Mode Accuracy						
Common Mode Match 1/1	VDC _{CMM}	- 5	±1	5	mV	
Noise						
Noise (OUT± Unloaded) (Note 23)	N _{OUT}	1/1 -> 1x	-	6	-	μV _{rms}
		1/2 -> 2x	-	7	-	μV _{rms}
		1/4 -> 4x	-	7	-	μV _{rms}
		1/8 -> 8x	-	7	-	μV _{rms}
		1/16 -> 16x	-	7	-	μV _{rms}
		1/32 -> 32x	-	9	-	μV _{rms}
		1/64 -> 64x	-	14	-	μV _{rms}
Noise (BUF± Unloaded, 1 kΩ load) (Note 23, 24)	N _{BUF}	1/1 -> 1x	-	7	-	μV _{rms}
		1/2 -> 2x	-	10	-	μV _{rms}
		1/4 -> 4x	-	17	-	μV _{rms}
		1/8 -> 8x	-	33	-	μV _{rms}
		1/16 -> 16x	-	64	-	μV _{rms}
		1/32 -> 32x	-	130	-	μV _{rms}
		1/64 -> 64x	-	257	-	μV _{rms}

DAC DC DIFFERENTIAL MODE 5

Parameter		Symbol	Min	Typ	Max	Unit
DC Differential Mode Characteristics						
Full-scale Differential DC Output (Note 26)	1/1	VDC _{FS}	-	2.5	-	V
	1/2		-	1.25	-	V
	1/4		-	625	-	mV
	1/8		-	312.5	-	mV
	1/16		-	156.25	-	mV
	1/32		-	78.125	-	mV
	1/64		-	39.0625	-	mV
DC Differential Accuracy						
Full-scale Accuracy (Note 3, 21)	1/1	VDC _{ABS}	- 1.0	- 0.4	0.2	%FS
Relative Accuracy (Note 22)	1/2	VDC _{REL}	- 0.2	± 0.1	0.2	%
	1/4		-	± 0.1	-	%
	1/8		-	-0.1 ± 0.4	-	%
	1/16		-	-0.2 ± 0.9	-	%
	1/32		-	-0.5 ± 1.7	-	%
	1/64		-	-1.0 ± 3.6	-	%
Full-scale Drift (Note 17)		VDC _{TC}	-	25	-	μV/°C
DC Common Mode Characteristics						
Common Mode (Note 13)		VDC _{CM}	-	(VA-)+2.35	-	V
Common Mode Drift (Note 13, 17)		VDC _{CMTC}	-	300	-	μV/°C
Noise						
Noise (OUT± Unloaded) (Note 23, 26)	1/1 -> 1x	N _{OUT}	-	9	-	μV _{rms}
	1/2 -> 2x		-	9	-	μV _{rms}
	1/4 -> 4x		-	9	-	μV _{rms}
	1/8 -> 8x		-	9	-	μV _{rms}
	1/16 -> 16x		-	10	-	μV _{rms}
	1/32 -> 32x		-	11	-	μV _{rms}
	1/64 -> 64x		-	15	-	μV _{rms}
Noise (BUF± Unloaded, 1 kΩ load) (Note 23, 24, 26)	1/1 -> 1x	N _{BUF}	-	10	-	μV _{rms}
	1/2 -> 2x		-	12	-	μV _{rms}
	1/4 -> 4x		-	18	-	μV _{rms}
	1/8 -> 8x		-	32	-	μV _{rms}
	1/16 -> 16x		-	67	-	μV _{rms}
	1/32 -> 32x		-	122	-	μV _{rms}
	1/64 -> 64x		-	265	-	μV _{rms}

Notes: 26. DC differential output is chopper stabilized and includes low-level 32 kHz out-of-band noise which is rejected by the digital filter during acquisition.

DAC AC COMMON MODE 6

Parameter		Symbol	Min	Typ	Max	Unit
AC Common Mode Characteristics						
Full-scale Common Mode AC Output (Note 27)	1/1	VCM _{FS}	-	2.5	-	V _{pp}
	1/2		-	1.25	-	V _{pp}
	1/4		-	625	-	mV _{pp}
	1/8		-	312.5	-	mV _{pp}
	1/16		-	156.25	-	mV _{pp}
	1/32		-	78.125	-	mV _{pp}
Full-scale Bandwidth	(Note 9)	VCM _{BW}	-	-	100	Hz
Impulse Amplitude	(Note 9, 20)	VCM _{IMP}	-	-	-20	dBfs
AC Common Mode Accuracy						
Common Mode Match (OUT± Unloaded) (Note 16, 27)		VCM _{CMM}	-	-115	-105	dB
Common Mode Match (BUF± Unloaded, 1 kΩ load) (Note 16, 24, 27)		VCM _{CMM}	-	-95	-85	dB
Full-scale Accuracy (Note 3, 21)	1/1	VCM _{ABS}	-	-0.3	-	%FS
Relative Accuracy (Note 22)	1/2	VCM _{REL}	-	-0.1	-	%
	1/4		-	-0.5	-	%
	1/8		-	-1.0	-	%
	1/16		-	-2.0	-	%
	1/32		-	-5.0	-	%
Full-scale Drift	(Note 17)	VCM _{TC}	-	25	-	μV/°C
DC Common Mode Characteristics						
Common Mode Mean	(Note 28)	VCM _{CM}	-	(VA-)+2.35	-	V
Common Mode Mean Drift	(Note 17, 28)	VCM _{CMTC}	-	300	-	μV/°C

Notes: 27. No AC common mode signal is output at 1/64 attenuation due to the attenuator architecture.

28. Common mode mean is defined as [(SIG_{max}) + (SIG_{min})] / 2.

DIGITAL CHARACTERISTICS

Parameter	Symbol	Min	Typ	Max	Unit
Digital Inputs					
High-level Input Voltage (Note 9, 29)	V_{IH}	$0.6 \cdot V_D$	-	V_D	V
Low-level Input Voltage (Note 9, 29)	V_{IL}	0.0	-	0.8	V
Input Leakage Current	I_{IN}	-	± 1	± 10	μA
Digital Input Capacitance (Note 9)	C_{IN}	-	9	-	pF
Input Rise Times Except MCLK (Note 9)	t_{RISE}	-	-	100	ns
Input Fall Times Except MCLK (Note 9)	t_{FALL}	-	-	100	ns
Digital Outputs					
High-level Output Voltage, $I_{out} = -40 \mu A$ (Note 9)	V_{OH}	$V_D - 0.3$	-	-	V
Low-level Output Voltage, $I_{out} = 40 \mu A$ (Note 9)	V_{OL}	-	-	0.3	V
High-Z Leakage Current	I_{OZ}	-	-	± 10	μA
Digital Output Capacitance (Note 9)	C_{OUT}	-	9	-	pF
Output Rise Times (Note 9)	t_{RISE}	-	-	100	ns
Output Fall Times (Note 9)	t_{FALL}	-	-	100	ns

Notes: 29. Device is intended to be driven with CMOS logic levels.

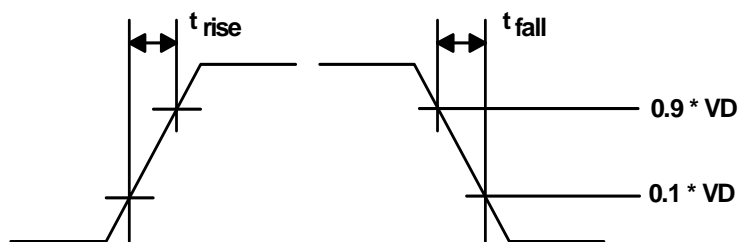
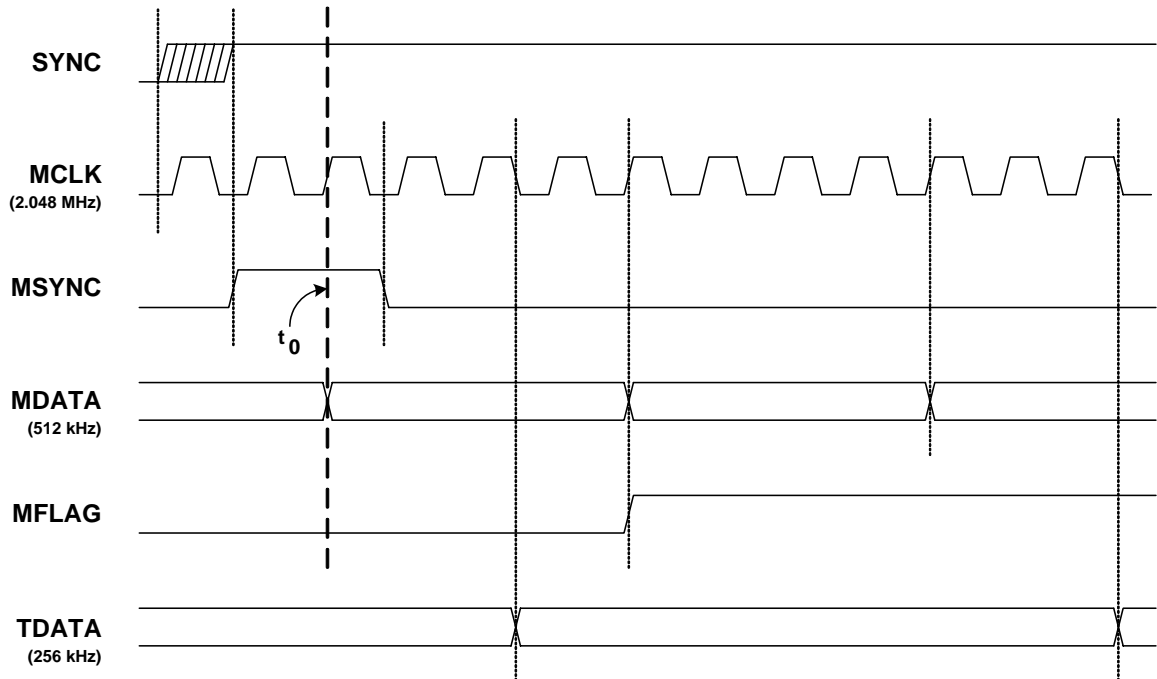
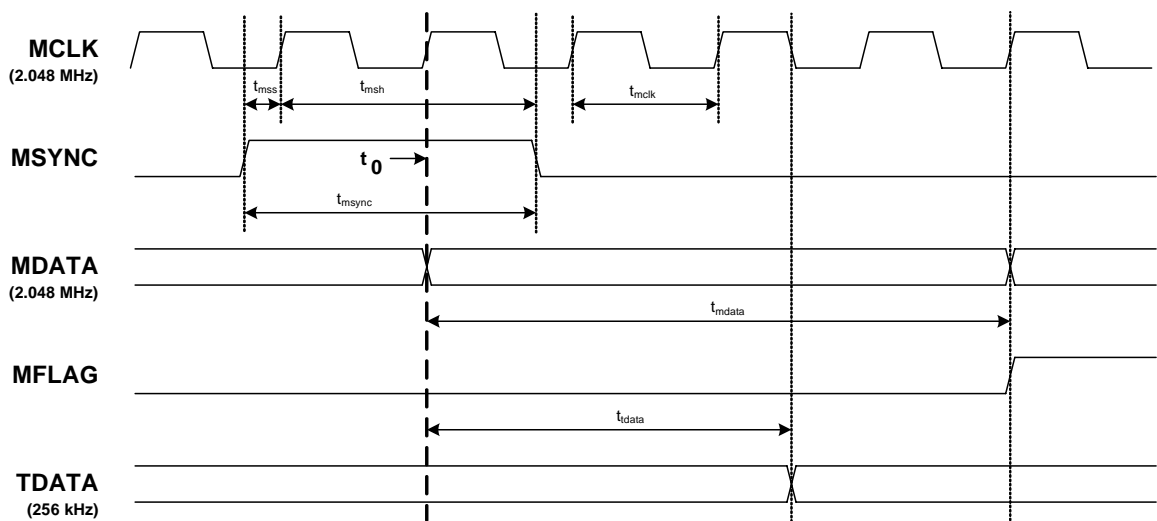

Figure 3. Digital Input Rise and Fall Times

DIGITAL CHARACTERISTICS (CONT.)

Parameter	Symbol	Min	Typ	Max	Unit
Master Clock Input					
MCLK Frequency (Note 30)	f_{CLK}	-	2.048	-	MHz
MCLK Period (Note 30)	t_{mclk}	-	488	-	ns
MCLK Duty Cycle (Note 9)	MCLK_{DC}	40	-	60	%
MCLK Rise Time (Note 9)	t_{RISE}	-	-	50	ns
MCLK Fall Time (Note 9)	t_{FALL}	-	-	50	ns
MCLK Jitter (In-band or aliased in-band) (Note 9)	MCLK_{IBJ}	-	-	300	ps
MCLK Jitter (Out-of-band) (Note 9)	MCLK_{OBJ}	-	-	1	ns
Master Sync Input					
MSYNC Setup Time to MCLK Rising (Note 9, 31)	t_{mss}	20	122	-	ns
MSYNC Period (Note 9, 31)	t_{msync}	40	976	-	ns
MSYNC Hold Time after MCLK Falling (Note 9, 31)	t_{msh}	20	122	-	ns
MSYNC Instant to TDATA Start (Note 9, 32)	t_{tdata}	-	1220	-	ns
MDATA Output					
MDATA Output Bit Rate	f_{mdata}	-	512	-	kbits/s
MDATA Output Bit Period	t_{mdata}	-	1953	-	ns
MDATA Output One's Density Range (Note 9)	MDAT_{OD}	14	-	86	%
Full-scale Output Code (Note 33)	MDAT_{FS}	0xA2EBE0	-	0x5D1420	
TDATA Input					
TDATA Input Bit Rate (Note 34)	f_{tdata}	-	256	-	kbits/s
TDATA Input One's Density Range (Note 9)	TBS_{OD}	25	-	75	%
TBSGAIN Full-scale Code (Note 35)	TBS_{FS}	-	0x04B8F2	-	
TBSGAIN -20 dB Code (Note 35)	$\text{TBS}_{\text{-20dB}}$	-	0x0078E5	-	

- Notes: 30. MCLK is generated by the CS5378 digital filter. If MCLK is disabled, the device automatically enters a power-down state.
31. MSYNC is generated by the CS5378 digital filter and is latched on MCLK rising edge, synchronization instant (t_0) on next MCLK rising edge.
32. TDATA can be delayed from 0 to 63 full bit periods by the test bit stream generator in the CS5378 digital filter. The timing diagrams show no TBSDATA delay.
33. Decimated, filtered, and offset-corrected 24-bit output word from the CS5378 digital filter.
34. TDATA is generated by the test bit stream generator in the CS5378 digital filter.
35. TBSGAIN register value in the CS5378 digital filter.

DIGITAL CHARACTERISTICS (CONT.)

Figure 4. System Timing Diagram

Figure 5. MCLK / MSYNC Timing Detail

POWER SUPPLY CHARACTERISTICS

Parameter	Symbol	Min	Typ	Max	Unit
Modulator Supply Current (MODE = 0, 1, 2, 3, 4, 5, 6)					
Analog Power Supply Current (Note 36)	I_A	-	5	6	mA
Digital Power Supply Current (Note 36)	I_D	-	75	-	μ A
Modulator Sleep Current (MODE = 7)					
Analog Power Supply Current (Note 36)	I_A	-	0.5	-	mA
Digital Power Supply Current (Note 36)	I_D	-	75	-	μ A
DAC AC Mode Supply Current (MODE = 1, 2, 3, 6)					
Analog Power Supply Current (Note 36)	I_A	-	8	10	mA
Digital Power Supply Current (Note 36)	I_D	-	20	-	μ A
DAC DC Mode Supply Current (MODE = 4)					
Analog Power Supply Current (Note 36)	I_A	-	2.7	-	mA
Digital Power Supply Current (Note 36)	I_D	-	20	-	μ A
DAC DC Mode Supply Current (MODE = 5)					
Analog Power Supply Current (Note 36)	I_A	-	4.2	-	mA
Digital Power Supply Current (Note 36)	I_D	-	20	-	μ A
DAC Sleep Current (MODE = 0, 7)					
Analog Power Supply Current (Note 36)	I_A	-	0.2	-	mA
Digital Power Supply Current (Note 36)	I_D	-	20	-	μ A
Chip Power Down Current (MCLK = OFF)					
Analog Power Supply Current (Note 36)	I_A	-	1	-	μ A
Digital Power Supply Current (Note 36)	I_D	-	20	-	μ A
Time to Enter Power Down (MCLK disabled) (Note 9)	PD_{TC}	-	40	-	μ S
Power Supply Rejection					
Power Supply Rejection Ratio (Note 37)	PSRR	-	90	-	dB

Notes: 36. All outputs unloaded. Digital inputs forced to VD or GND respectively.

37. Power supply rejection is characterized by applying a 100 mVp-p 50-Hz sine wave to each supply.

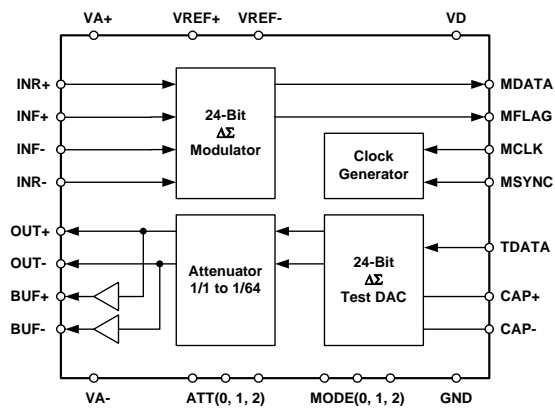

Figure 6. CS5373A Block Diagram

2. GENERAL DESCRIPTION

The CS5373A is a high-performance, fourth-order $\Delta\Sigma$ modulator integrated with a digital-to-analog converter (DAC). When combined with a CS3301A / CS3302A differential amplifier and a CS5378 digital filter, a small low-power self-testing high-accuracy single-channel measurement system results.

2.1 Delta-Sigma Modulator

The CS5373A modulator has high dynamic range and low total harmonic distortion with very low power consumption, and is optimized for extremely high-resolution measurement of $5 V_{pp}$ or smaller differential signals. It converts analog input signals between DC and 2000 Hz to an oversampled serial bit stream at 512 kbits per second.

The CS5378 digital filter generates the clock and synchronization inputs for the modulator while receiving the modulator one-bit data and over-range flag outputs. The digital filter then decimates the modulator's oversampled output bit stream to a 24-bit output at the selected output word rate.

2.2 Digital-to-Analog Converter

The CS5373A test DAC is driven by a digital $\Delta\Sigma$ bit stream from the CS5378 digital filter's test bit stream (TBS) generator and operates in either AC or DC test modes. AC test modes

(MODE 1, 2, 3, 6) are used to measure system THD and CMRR performance. DC test modes (MODE 4, 5) are for gain calibration and pulse tests. The digital filter also provides clock and synchronization signals as well as GPIO control signals to set the operational mode and analog output attenuation.

Two sets of differential analog outputs, *OUT* and *BUF*, simplify system design as dedicated outputs for testing the electronics channel and for in-circuit sensor tests. Output attenuator settings are binary weighted (1, 1/2, 1/4, 1/8, 1/16, 1/32, 1/64) and match the CS3301A / CS3302A amplifier input levels for full-scale testing at all gain ranges.

For maximum performance, the precision outputs (*OUT* \pm) must drive only high-impedance loads such as the CS3301A / CS3302A amplifier inputs. The buffered outputs (*BUF* \pm) can drive lower-impedance loads, down to 1 k Ω , but with reduced performance compared to the precision outputs.

The test DAC is optimized for low-power operation and has a restricted operational bandwidth in the AC modes. For stable operation, full-scale AC test signals must not contain frequencies above 100 Hz. AC test signals above 100 Hz (TBS impulse mode, for example) must have a -20 dB reduced amplitude to ensure stability of the low-power $\Delta\Sigma$ architecture.

3. SYSTEM DIAGRAM

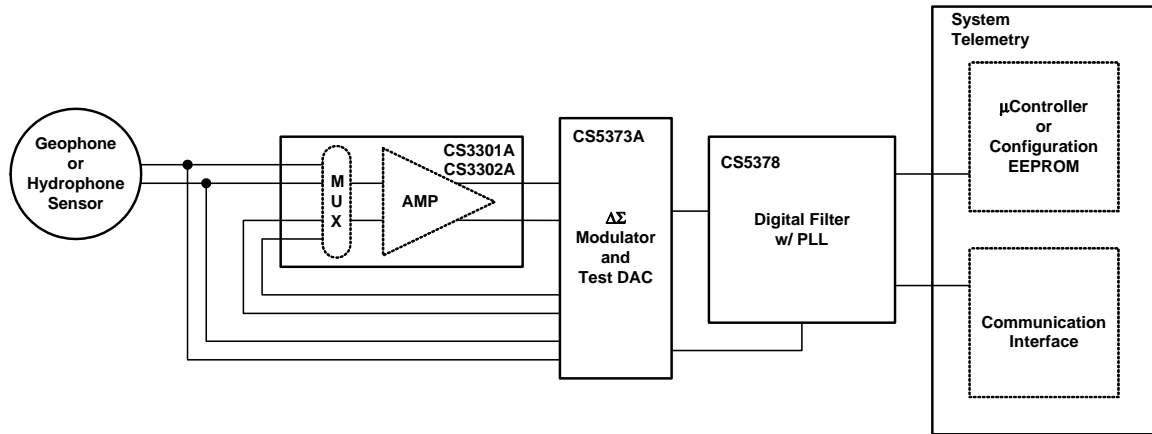

Figure 7. System Diagram

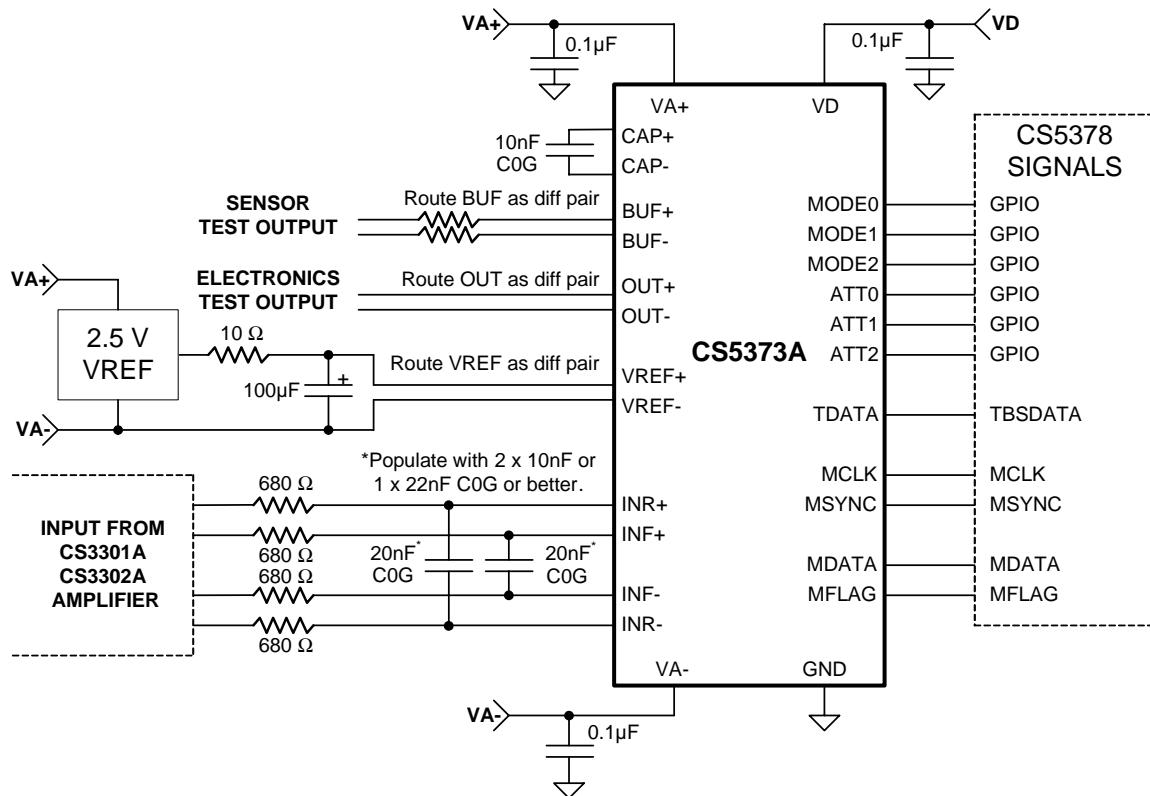

Figure 8. Connection Diagram

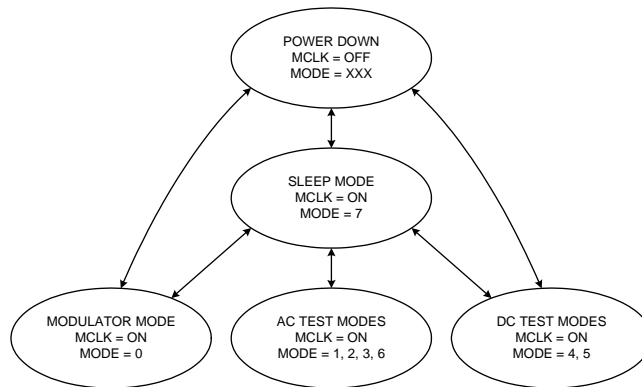

Figure 9. Power Mode Diagram

4. POWER MODES

The CS5373A has five power modes. Modulator mode, AC test modes, and DC test modes are operational modes, while power down and sleep mode are non-operational standby modes.

4.1 Power Down

If MCLK is stopped, an internal loss-of-clock detection circuit automatically places the CS5373A into power down. Power down is independent of the MODE and ATT pin settings, and is automatically invoked after approximately 40 μ s without an incoming MCLK edge.

In power down the modulator, AC test circuitry and DC test circuitry are inactive and all outputs are high impedance. When used with the CS5378 digital filter, the CS5373A is in power down immediately after reset since MCLK is disabled by default.

4.2 Sleep Mode

With MCLK active, selecting sleep mode (MODE 7) places the CS5373A into a micro-power sleep state. In sleep mode the modulator, AC test circuitry and DC test circuitry are inactive and all outputs are high impedance.

4.3 Modulator Mode

With MCLK active, selecting modulator mode

(MODE 0) enables the CS5373A modulator and places the AC and DC test circuitry into a micro-power sleep state with the analog test outputs high impedance. Following completion of AC and DC system self-tests, the CS5373A is typically set into modulator mode for normal data acquisition.

4.4 AC Test Modes

With MCLK and TDATA active, selecting an AC test mode (MODE 1, 2, 3, 6) enables the modulator and causes the DAC to output AC waveforms on the analog test outputs. AC test modes use the low-power $\Delta\Sigma$ DAC circuitry in the CS5373A to create precision differential or common mode analog AC output signals from the encoded digital test bit stream (TBS) input.

4.5 DC Test Modes

With MCLK active, selecting a DC test mode (MODE 4, 5) enables the modulator and causes the DAC to generate precision DC voltages on the analog test outputs. DC test modes use switch-capacitor level-shifting buffer circuitry in the CS5373A to create differential or common mode DC analog output voltages from the voltage reference input.

5. OPERATIONAL MODES

The CS5373A has seven operational modes and one sleep mode selected by the MODE2, MODE1, and MODE0 pins.

Modes of Operation		
Selection	MODE [2:0]	Mode Description
0	0 0 0	Modulator: enabled. DAC: sleep.
1	0 0 1	Modulator: enabled. DAC: AC OUT and BUF outputs.
2	0 1 0	Modulator: enabled. DAC: AC OUT only, BUF high-z.
3	0 1 1	Modulator: enabled. DAC: AC BUF only, OUT high-z.
4	1 0 0	Modulator: enabled. DAC: DC common mode output.
5	1 0 1	Modulator: enabled. DAC: DC differential output.
6	1 1 0	Modulator: enabled. DAC: AC common mode output.
7	1 1 1	Modulator: sleep. DAC: sleep.

Table 2. Operational Modes

5.1 Modulator Mode

Modulator mode (MODE 0) enables the $\Delta\Sigma$ modulator and disables the DAC AC and DC test circuitry to save power. This mode is used for normal sensor measurements after self-tests are completed.

5.1.1 Modulator One's Density

In modulator mode (and whenever the modulator is enabled) the differential analog input signal is converted to an oversampled $\Delta\Sigma$ serial bit stream on the MDATA output, with a one's density proportional to the differential amplitude of the analog input signal.

One's density of the MDATA output is defined as the ratio of '1' bits to total bits in the serial

bit stream output, i.e. an 86% one's density has, on average, a '1' value in 86 of every 100 output data bits. The MDATA output has a nominal 50% one's density for a mid-scale differential input, approximately 86% one's density for a positive full-scale input, and approximately 14% one's density for a negative full-scale input.

5.1.2 Modulator Decimated Output

When the CS5373A modulator operates with the CS5378 digital filter, the final decimated, 24-bit, full-scale output code range depends if digital offset correction is enabled. With digital offset correction enabled, amplifier offset and the modulator internal offset are removed from the final conversion result.

Modulator Differential Analog Input Signal	CS5378 Digital Filter Output Code	
	Offset Corrected	+100 mV Offset
> + (VREF + 5%)	Error Flag Possible	
+ VREF	5D1420	60CD40
0 V	000000	03B920
- VREF	A2EBE0	A6A500
> - (VREF + 5%)	Error Flag Possible	

Table 3. Output Coding for the CS5373A Modulator and CS5378 Digital Filter Combination

5.1.3 Modulator Synchronization

The modulator is designed to operate synchronously with other modulators in a measurement network, so a rising edge on the MSYNC input resets the internal conversion state machine to synchronize analog sample timing. MSYNC is automatically generated by the CS5378 digital filter after receiving a synchronization signal from the external system, and is chip-to-chip accurate within ± 1 MCLK period.

5.1.4 Modulator Idle Tones

The CS5373A modulator is $\Delta\Sigma$ type and so can produce 'idle tones' in the measurement bandwidth when the differential input signal is a steady-state DC signal near mid-scale. Idle tones result from low-frequency patterns in the output bit stream and appear in the measurement spectrum as small tones about -135 dB down from full scale.

Idle tones are eliminated within the CS5373A modulator by automatically adding +100 mV of internal differential offset during conversion to push idle tones out of the measurement bandwidth. Care should be taken to ensure external offset voltages do not negate the internally added differential offset.

5.1.5 Modulator Stability

The CS5373A's $\Delta\Sigma$ modulator has a 4th order architecture which is conditionally stable and may go into an oscillatory condition if the analog inputs are over-ranged more than 5% past either positive or negative full scale.

If an unstable condition is detected, the modulator collapses to a 1st order system and transitions the MFLAG output low-to-high to signal an error condition to the CS5378 digital filter. The analog input signal must be reduced to within the full-scale range for at least 32 MCLK cycles for the modulator to recover from an oscillatory condition. If the analog input remains over-ranged for an extended period, the modulator will cycle between 4th order and 1st order operation and the MFLAG output will be seen to pulse.

5.2 AC Test Modes

AC test modes (MODE 1, 2, 3, 6) enable the modulator and use the digital test bit stream (TBS) input from the CS5378 digital filter to construct analog AC waveforms. The digital bit stream input to the TDATA pin encodes the analog waveform as over-sampled one-bit $\Delta\Sigma$ data, which is then converted into precision differential or common mode analog AC sig-

nals by the CS5373A's test DAC.

5.2.1 AC Differential

The first three AC test modes (MODE 1, 2, 3) enable the modulator and AC test circuitry to create precision differential analog signals for THD and impulse testing of the measurement channel. In mode 1, both sets of differential analog outputs (*OUT* and *BUF*) are enabled. In mode 2 only the *OUT* analog output is enabled, and the *BUF* output is high impedance. In mode 3 only the *BUF* analog output is enabled, and the *OUT* output is high impedance.

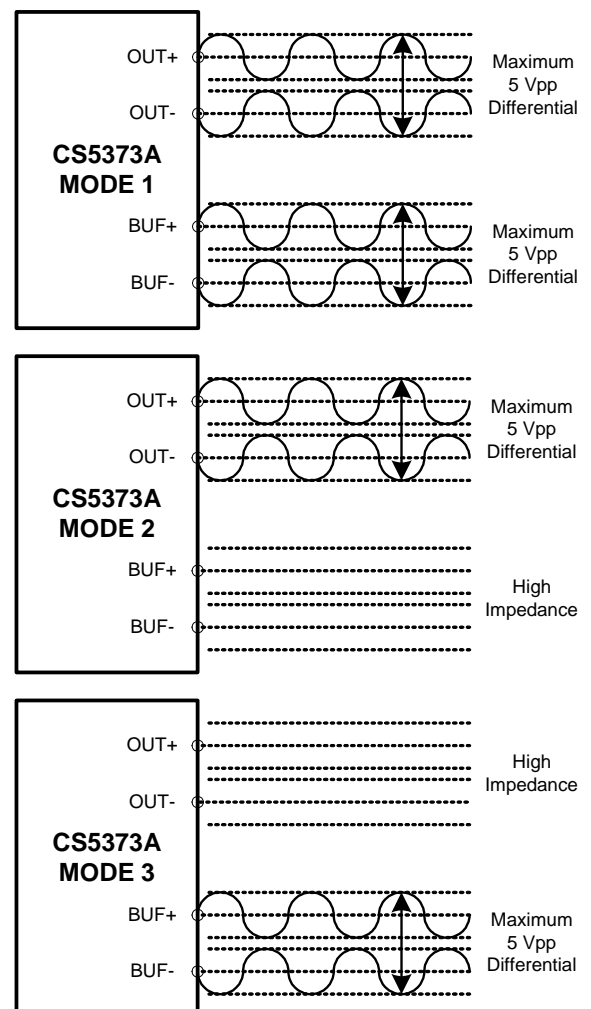

Figure 10. AC Differential Modes

Differential AC test signals out of the CS5373A consist of two halves with equal but opposite magnitude, varying about a common mode voltage. A full-scale 5 V_{pp} differential AC signal centered on a -0.15 V common mode voltage will have:

$$\text{SIG+} = -0.15 \text{ V} + 1.25 \text{ V} = +1.1 \text{ V}$$

$$\text{SIG-} = -0.15 \text{ V} - 1.25 \text{ V} = -1.4 \text{ V}$$

SIG+ is +2.5 V relative to SIG-

For the opposite case:

$$\text{SIG+} = -0.15 \text{ V} - 1.25 \text{ V} = -1.4 \text{ V}$$

$$\text{SIG-} = -0.15 \text{ V} + 1.25 \text{ V} = +1.1 \text{ V}$$

SIG+ is -2.5 V relative to SIG-

So the total swing for SIG+ relative to SIG- is (+2.5 V) - (-2.5 V) = 5 V_{pp} differential. A similar calculation can be done for SIG- relative to SIG+.

It's important to note that a 5 V_{pp} differential signal centered on a -0.15 V common mode voltage never exceeds +1.1 V with respect to ground and never drops below -1.4 V with respect to ground on either half. By definition, differential voltages are measured with respect to the opposite half, not relative to ground. A voltmeter differentially measuring between SIG+ and SIG- in the above example would correctly read 1.767 V_{rms}, or 5 V_{pp}.

5.2.2 AC Common Mode

The final AC test mode (MODE 6) enables the modulator and AC test circuitry to create a

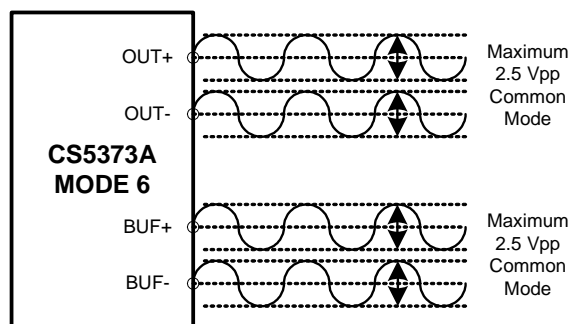

Figure 11. AC Common Mode

matched AC common mode analog signal for CMRR testing of the measurement channel. In mode 6, both sets of analog outputs (*OUT* and *BUF*) are enabled. There is no AC common mode output for an attenuator setting of 1/64. Gross leakage in the sensor channel can be detected by applying a full-scale AC common mode signal. If there is a significant differential mismatch in the channel due to sensor leakage, the AC common mode signal will be converted to a measurable differential signal at the fundamental frequency.

5.2.3 DAC Stability

For the CS5373A's low-power $\Delta\Sigma$ DAC architecture to remain stable, the TDATA input bit stream should only encode 100 Hz or lower bandwidth analog signals. For TDATA bit stream frequencies above 100 Hz (for example, TBS impulse mode), the encoded amplitude must be reduced -20 dB below full scale to guarantee stability.

If the CS5373A's low-power $\Delta\Sigma$ DAC architecture becomes unstable, persistent elevated noise will be present on the analog outputs and AC linearity will be poor. To recover stability, place the CS5373A into power down or sleep mode and restart the CS5378 test bit stream generator before placing the CS5373A back into an AC test mode.

5.3 DC Test Modes

DC test modes enable the modulator and DC test circuitry to create precision level-shifted and buffered versions of the voltage reference input as precision DC common mode and DC differential analog outputs. The absolute accuracy of the DC test modes is highly dependent on the absolute accuracy of the voltage reference input voltage.

5.3.1 DC Common Mode

The first DC test mode (MODE 4) enables the modulator and DC test circuitry to create a matched DC common mode analog output voltage as a baseline measurement for gain

calibration and differential pulse tests. In mode 4, both sets of analog outputs (*OUT* and *BUF*) are enabled.

5.3.2 DC Differential

The second DC test mode (MODE 5) enables the modulator and DC test circuitry to create a precision differential DC analog output voltage as the final measurement for gain calibration and as the step/pulse output for differential pulse tests. In mode 5, both sets of analog outputs (*OUT* and *BUF*) are enabled.

In DC differential mode (MODE 5), level-shifting buffer circuitry adds low-level 32 kHz switched-capacitor noise to the DC output. This noise is out of the measurement bandwidth for systems designed with a CS3301A / CS3302A amplifier and CS5373A modulator and is rejected by the CS5378 digital filter. This 32 kHz noise does not affect DC system tests, though it may be visible on an oscilloscope at high gain levels.

By measuring both DC test modes (MODE 4, 5), precision gain-calibration coefficients

can be calculated for the measurement channel. By first measuring the differential offset of the DC common mode output (MODE 4) and then measuring the DC differential mode amplitude (MODE 5), a precise offset-corrected, volts-to-codes conversion ratio can be calculated. This known ratio is then used along with the CS5378 digital filter GAIN register to normalize the full-scale amplitude to match other channels in the measurement network.

By switching between DC common mode (MODE 4) and DC differential mode (MODE 5), pulse waveforms can be created to characterize the step response of the measurement channel. If a pulse test requires precise timing control, an external controller should directly toggle the MODE pins of the CS5373A to avoid delays associated with writing to the CS5378 digital filter GPIO register.

Sensor impedance can be measured using DC differential mode (MODE 5), provided matched series resistors are installed between the *BUF* analog outputs and the sensor. Applying the known DC differential voltage to the resistor-sensor-resistor string permits a ratio-metric sensor impedance calculation from the measured voltage drop across the sensor.

Switching between DC differential mode (MODE 5) and modulator mode (MODE 0) can, in the case of a moving-coil geophone, test basic parameters of the electro-mechanical transfer function. The voltage relaxation characteristic of the sensor when switching the analog outputs from a differential DC voltage to high impedance depends primarily on the geophone resonant frequency and damping factor.

5.4 Sleep Mode

Sleep mode (MODE 7) saves system power when measurements are not required by turning off the modulator, AC test circuitry, and DC test circuitry. In sleep mode the modulator digital outputs and the *BUF* and *OUT* analog outputs are high impedance.

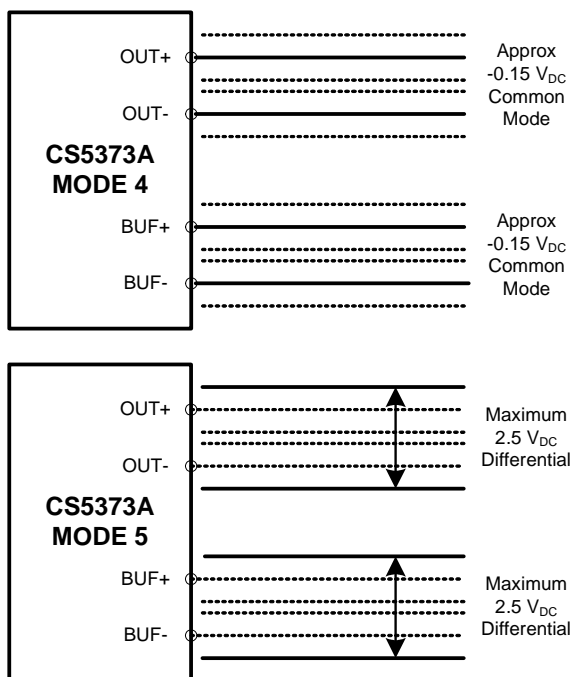

Figure 12. DC Test Modes

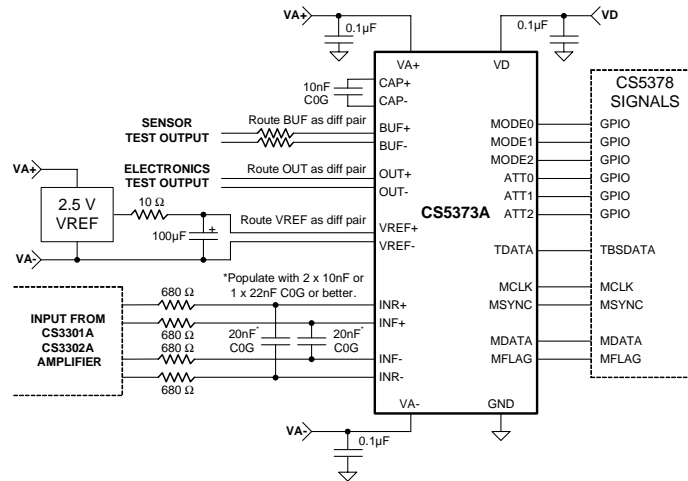

Figure 13. Digital Signals

6. DIGITAL SIGNALS

The CS5373A is designed to operate with the CS5378 digital filter. The digital filter generates the master clock and synchronization signals (MCLK and MSYNC) while receiving back the modulator one-bit $\Delta\Sigma$ conversion data (MDATA) and over-range flag (MFLAG). It also generates digital one-bit $\Delta\Sigma$ test bit stream data for the test DAC (TDATA) and controls GPIO pins to set the operational mode (MODE) and attenuation (ATT).

6.1 MCLK Connection

The CS5378 digital filter generates the master clock for CS5373A, typically 2.048 MHz, from a synchronous CLK input from the external system. By default, MCLK is disabled at reset and is enabled by writing the digital filter CONFIG register. If MCLK is disabled during operation, the CS5373A will enter power down after approximately 40 μ S.

MCLK must have low in-band jitter to guarantee full analog performance, requiring a crystal- or VCXO-based system clock into the digital filter. Clock jitter on the digital filter external CLK input directly translates to jitter on MCLK.

6.2 MSYNC Connection

The CS5378 digital filter also provides a synchronization signal to the CS5373A. The MSYNC signal is generated following a rising edge received on the digital filter SYNC input. By default MSYNC generation is disabled at reset and is enabled by writing to the digital filter CONFIG register.

The input SYNC signal to the CS5378 digital filter sets a common reference time t_0 for measurement events, thereby synchronizing analog sampling across a measurement network. The timing accuracy of the received SYNC signal from node to node must be ± 1 MCLK to maximize the MSYNC analog sample synchronization accuracy.

The CS5373A MSYNC input is rising-edge triggered and resets the internal MCLK counter/divider to guarantee synchronous operation with other system devices. While the MSYNC signal synchronizes the internal operation of the CS5373A, by default, it does not synchronize the phase of the incoming encoded digital test bit stream (TBS) sine wave unless enabled in the digital filter TBSCFG register.

6.3 MDATA Connection

The CS5373A modulator outputs a $\Delta\Sigma$ serial bit stream to the MDATA pin, with a one's density proportional to the differential amplitude of the analog input signal. The output bit rate from the MDATA output is a divide-by-four of the input master clock, and so is nominally 512 kHz.

The MDATA output has a nominal 50% one's density for mid-scale input, approximately 86% one's density for a positive full-scale input, and approximately 14% one's density for a negative full-scale input. One's density of the MDATA output is defined as the ratio of '1' bits to total bits in the serial bit stream output, i.e. an 86% one's density has, on average, a '1' value in 86 of every 100 output data bits.

6.4 MFLAG Connection

The CS5373A $\Delta\Sigma$ modulator has a 4th order architecture which is conditionally stable and may go into an oscillatory condition if the analog inputs are over-ranged more than 5% past either positive or negative full-scale.

If an unstable condition is detected, the modulator collapses to a 1st order system and transitions the MFLAG output low-to-high to signal an error condition to the CS5378 digital filter. The analog signal must be reduced to within the full-scale input range for at least 32 MCLK cycles for the modulator to recover from an oscillatory condition. If the analog input remains over-ranged for an extended period, the modulator will cycle between 4th order and 1st order operation and the MFLAG output will be seen to pulse.

The MFLAG output connects to a dedicated input on the CS5378 digital filter, causing an error flag to be set in the status portion of the next conversion output data word.

6.5 TDATA Connection

The TDATA digital input to the test DAC expects encoded one-bit $\Delta\Sigma$ data nominally at a 256 kHz rate. The one's density input range is

approximately 25% minimum to 75% maximum, with differential mid-scale at 50% one's density.

The CS5378 digital filter test bit stream (TBS) generator can encode two types of AC signals as over-sampled, one-bit $\Delta\Sigma$ data – a pure sine wave for THD and CMRR testing or a triggerable impulse waveform for synchronization testing and impulse response characterization. In the AC test modes, the test DAC converts the over-sampled test bit stream digital data into precision differential or common mode analog AC signals.

The CS5378 TBS sine mode encodes an approximately 5 V_{pp} full-scale sine wave signal with a digital filter TBSGAIN register setting of 0x04B8F2. Because TBS impulse mode encodes frequencies above 100 Hz, a maximum 0x0078E5 TBSGAIN impulse mode register setting is specified to guarantee stability of the DAC low-power $\Delta\Sigma$ circuitry. Details on the setup and operation of the digital filter test bit-stream (TBS) generator can be found in the CS5378 data sheet.

6.6 GPIO Connections

The CS5378 controls 8 general-purpose input output (GPIO) pins through the digital filter GPCFG register. These GPIO pins are typically assigned to operate the CS5373A mode and attenuator pins, along with the CS3301A / CS3302A amplifier input mux and gain pins. The gain and attenuation settings of the CS3301A / CS3302A amplifiers and the CS5373A test DAC are identically decoded to allow full-scale performance testing at all system gain ranges with shared GAIN and ATT control signals.

If precise timing control of operational modes is required (for example, switching between DC modes for pulse generation), an external controller should directly toggle the MODE pins of the CS5373A to avoid the delay associated with writing to the CS5378 digital filter GPCFG register.

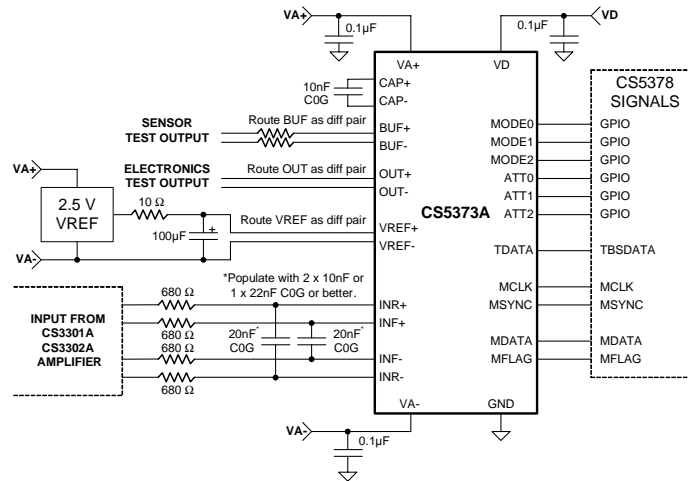

Figure 14. Analog Signals

7. ANALOG SIGNALS

The CS5373A has multiple differential analog inputs and outputs. The modulator analog inputs are separated into rough and fine charge differential pairs (INR_{\pm} , INF_{\pm}) for maximum sampling accuracy. Both sets of modulator inputs require a simple differential anti-alias RC filter to ensure high-frequency signals do not alias into the measurement bandwidth.

The test DAC has a precision differential output (OUT_{\pm}) that provides the best analog performance, but with only minimal drive capability. A buffered output (BUF_{\pm}) can drive an external load, but with reduced analog performance. Finally, the test DAC internal anti-alias filter requires a dedicated capacitor connection (CAP_{\pm}) to eliminate undesired high-frequency signals.

7.1 INR_{\pm} , INF_{\pm} Modulator Inputs

The modulator analog inputs are separated into differential rough and fine signals (INR_{\pm} , INF_{\pm}). The positive half of the differential input signal is connected to $INR+$ and $INF+$, while the negative half is attached to $INF-$ and $INR-$. The INR_{\pm} pins are switched-capacitor 'rough charge' inputs that pre-charge the internal analog sampling capacitor before it is connected to the INF_{\pm} fine input pins.

7.1.1 Modulator Input Impedance

The modulator input has a dynamic switched-capacitor architecture and so has a rough charge input impedance that is inversely proportional to the input master clock frequency and the input capacitor size, $[1 / (f * C)]$.

- $MCLK = 2.048 \text{ MHz}$
- INR_{\pm} Input Cap = 20 pF
- Impedance = $[1 / (2.048 \text{ MHz} * 20 \text{ pF})] = 24 \text{ k}\Omega$.

Internal to the modulator, the rough inputs (INR_{\pm}) pre-charge the sampling capacitor used by the fine inputs (INF_{\pm}), therefore the input current to the fine inputs is very low and the effective input impedance is orders of magnitude above the impedance of the rough inputs.

7.1.2 Modulator Anti-alias Filter

The modulator inputs are required to be bandwidth limited to ensure modulator loop stability and prevent high-frequency signals from aliasing into the measurement band. The use of simple single-pole differential low-pass RC filters across the INR_{\pm} and INF_{\pm} inputs ensures high-frequency signals are rejected before they can alias into the measurement band.

The -3 dB corner of the input anti-alias filter is nominally set to the internal analog sampling rate divided by 64, which itself is a division by 4 of the MCLK input rate.

- MCLK Frequency = 2.048 MHz
- Sampling Frequency = MCLK / 4 = 512 kHz
- -3 dB Filter Corner = Sample Freq / 64 = 8 kHz
- RC filter = 8 kHz = $1 / [2\pi * (2 * R_{series}) * C_{diff}]$

Figure 14 illustrates the CS5373A modulator analog connections with input anti-alias filter components. Filter components on the rough and fine pins should be identical values for optimum performance, with the capacitor values a minimum of 0.02 μ F. The rough input can use either X7R or C0G type capacitors, while the fine input requires C0G type capacitors for optimal linearity. Using X7R type capacitors on the fine analog inputs will degrade total harmonic distortion significantly.

The CS3301A / CS3302A differential amplifiers are designed with separate rough and fine analog outputs (OUTR \pm , OUTF \pm) that match the rough and fine inputs to the modulator (INR \pm , INF \pm). External anti-alias series resistors and differential capacitors create the required anti-alias RC filters.

7.2 DAC Output Attenuation

The CS5373A test DAC has seven analog output attenuation settings from 1/1 to 1/64 selected with the ATT2, ATT1, and ATT0 pins. When enabled, attenuation is applied to both the OUT \pm and BUF \pm differential analog outputs. At 1/64 attenuation in AC Common Mode (MODE 6) there is no output signal amplitude

Selection	ATT[2:0]	Attenuation	dB
0	0 0 0	1/1	0 dB
1	0 0 1	1/2	-6.02 dB
2	0 1 0	1/4	-12.04 dB
3	0 1 1	1/8	-18.06 dB
4	1 0 0	1/16	-24.08 dB
5	1 0 1	1/32	-30.10 dB
6	1 1 0	1/64	-36.12 dB
7	1 1 1	reserved	reserved

Figure 15. DAC Output Attenuation Settings

due to the attenuator architecture.

The OUT \pm pins connect directly into the internal attenuator resistors and so attenuation accuracy is highly sensitive to load impedance on the OUT \pm pins. Loading on the BUF \pm pins does not affect attenuator accuracy.

The attenuation settings of CS5373A match the gain ranges of the CS3301A / CS3302A differential amplifiers to enable full-scale testing at all gain ranges. The CS3301A / CS3302A amplifier gain settings (GAIN) are decoded identical to the CS5373A attenuator settings (ATT) and so can share GPIO control signals from the CS5378 digital filter.

7.3 DAC OUT \pm Precision Output

The test DAC OUT \pm pins are precision differential analog outputs for testing the high-performance electronics measurement channel. These precision outputs have higher perfor-

mance specifications than the BUF± outputs, but with a much higher sensitivity to external loading. Excessive resistive or capacitive loading on the OUT± pins will degrade the analog performance characteristics of the test DAC in all operational modes.

The OUT± precision output is optimized for direct connection to the CS3301A / CS3302A amplifier differential inputs, which have very high input impedance. These amplifiers include a pin-controlled input multiplexer to switch between an internal differential termination for noise tests and two external differential inputs. One external input is typically dedicated to sensor measurements and the other to testing the electronics channel.

The OUT± outputs are enabled in all operational modes except modulator mode (MODE 0), “AC BUF Only” mode (MODE 3) and sleep mode (MODE 7). In these modes the OUT± pins are high impedance.

7.4 DAC BUF± Buffered Output

The test DAC BUF± pins are buffered differential analog outputs for testing external sensors such as geophones or hydrophones. The buffered outputs have reduced performance specifications compared with the OUT± outputs, but are less sensitive to external loading.

The BUF± outputs are enabled in all operational modes except modulator mode (MODE 0), “AC OUT Only” mode (MODE 2) and sleep mode (MODE 7). In these modes the BUF± pins are high impedance to ensure they do not interfere with sensor operation during normal data acquisition.

For sensor impedance testing, it is required to place matched series resistors in between the BUF± outputs and the differential sensor. With known series resistors and a known DC differential source voltage, sensor resistance can be calculated ratiometrically from the measured voltage drop across the sensor.

7.5 DAC CAP± Connection

The CS5373A test DAC requires a 10 nF C0G type capacitor to be connected differentially across the CAP± pins. This capacitor creates an internal anti-alias filter to eliminate high-frequency signals from the OUT± and BUF± analog outputs and helps to maintain the stability of the low-power ΔΣ DAC circuitry.

A COG, NPO or similar high-quality capacitor is required for CAP± since other capacitor types, such as X7R, do not have the required linearity. Using a poor-quality capacitor on CAP± will significantly degrade THD performance of the test DAC AC operational modes.

7.6 Analog Differential Signals

Differential AC test signals into and out of the CS5373A consist of two halves with equal but opposite magnitude varying about a common mode voltage. A full-scale 5 V_{PP} differential AC signal centered on a -0.15 V common mode voltage will have:

$$\text{SIG+} = -0.15 \text{ V} + 1.25 \text{ V} = +1.1 \text{ V}$$

$$\text{SIG-} = -0.15 \text{ V} - 1.25 \text{ V} = -1.4 \text{ V}$$

$$\text{SIG+ is } +2.5 \text{ V relative to SIG-}$$

For the opposite case:

$$\text{SIG+} = -0.15 \text{ V} - 1.25 \text{ V} = -1.4 \text{ V}$$

$$\text{SIG-} = -0.15 \text{ V} + 1.25 \text{ V} = +1.1 \text{ V}$$

$$\text{SIG+ is } -2.5 \text{ V relative to SIG-}$$

So the total swing for SIG+ relative to SIG- is (+2.5 V) - (-2.5 V) = 5 V_{pp} differential. A similar calculation can be done for SIG- relative to SIG+. It's important to note that a 5 V_{pp} differential signal centered on a -0.15 V common mode voltage never exceeds +1.1 V with respect to ground and never drops below -1.4 V with respect to ground on either half. By definition, differential voltages are measured with respect to the opposite half, not relative to ground. A voltmeter differentially measuring between SIG+ and SIG- in the above example would correctly read 1.767 V_{rms}, or 5 V_{pp}.

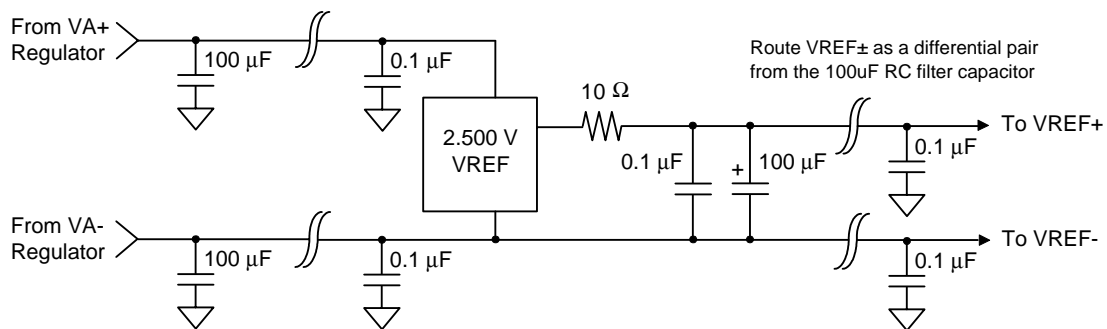

Figure 16. Voltage Reference Circuit

8. VOLTAGE REFERENCE

The CS5373A requires a 2.500 V precision voltage reference to be supplied to the VREF± pins.

8.1 VREF Power Supply

To guarantee proper regulation headroom for the voltage reference device, the voltage reference GND pin should be connected to VA- instead of system ground, as shown in [Figure 16](#). This connection results in a VREF- voltage equal to VA- and a VREF+ voltage very near ground [(VA-) + 2.500 VREF].

Power supply inputs to the voltage reference device should be bypassed to system ground with 0.1 µF capacitors placed as close as possible to the power and ground pins. In addition to 0.1 µF local bypass capacitors, at least 100 µF of bulk capacitance to system ground should be placed on each power supply near the voltage regulator outputs. Bypass capacitors should be X7R, C0G, tantalum, or other high-quality dielectric type.

8.2 VREF RC Filter

A primary concern in selecting a precision voltage reference device is noise performance in the measurement bandwidth. The [Linear Technology LT1019AIS8-2.5](#) voltage reference yields acceptable noise levels if the output is filtered with a low-pass RC filter.

A separate RC filter is required for each system device connected to a given voltage refer-

ence. By sharing a common RC filter, signal-dependent sampling of the voltage reference by one system device could cause unwanted tones to appear in the measurement bandwidth of another system device via common impedance coupling.

8.3 VREF PCB Routing

To minimize the possibility of outside noise coupling into the CS5373A voltage reference input, the VREF± traces should be routed as a differential pair from the large capacitor of the voltage reference RC filter. Careful control of the voltage reference source and return currents by routing VREF± as a differential pair will improve immunity from external noise.

To further improve noise rejection of the VREF± routing, include 0.1 µF bypass capacitors to system ground as close as possible to the VREF+ and VREF- pins of the CS5373A.

8.4 VREF Input Impedance

The switched-capacitor input architecture of the VREF± inputs results in an input impedance that depends on the internal capacitor size and the clock frequency. With a 15 pF internal capacitor and a 2.048 MHz MCLK the VREF input impedance is approximately $[1 / [(2.048 \text{ MHz}) * (15 \text{ pF})]] = 32 \text{ k}\Omega$. While the size of the internal capacitor is fixed, the voltage reference input impedance will vary

with MCLK.

The voltage reference external RC filter series resistor creates a voltage divider with the VREF input impedance to reduce the effective applied input voltage. To minimize gain error resulting from this voltage divider effect, the RC filter series resistor should be the minimum size recommended in the voltage reference device data sheet.

8.5 VREF Accuracy

The nominal voltage reference input is specified as 2.500 V across the $VREF_{\pm}$ pins, and all CS5373A gain accuracy specifications are measured with a nominal voltage reference input. Any variation from a nominal VREF input will proportionally vary the analog full-scale gain accuracy.

Since temperature drift of the voltage reference results in gain drift of the analog full-scale amplitude, care should be taken to minimize temperature drift effects through careful selection of passive components and the voltage reference device itself. Gain drift specifications of the CS5373A do not include the tempera-

ture drift effects of external passive components or of the voltage reference device itself.

8.6 VREF Independence

If the test signal source is required to be fully independent of the measurement channel, the CS5373A device cannot be used. Instead, a CS5371A modulator and a CS4373A test DAC should be used and connected to two independent voltage reference devices. This will eliminate the possibility for undetected ratiometric errors when the same voltage reference device is used by both the test signal source and the measurement channel.

Because modern precision voltage references are highly reliable, requirements for separate modulator and test DAC voltage references should be considered carefully. In the unlikely event of voltage reference failure independent of other system components, the CS5373A volts-to-codes ratio will be out of spec and measurement channel performance will be poor during system self-tests.

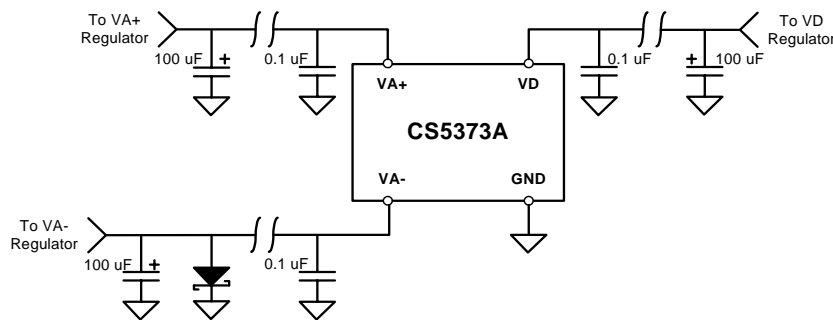

Figure 17. Power Supply Diagram

9. POWER SUPPLIES

The CS5373A has a positive analog power supply pin (VA+), a negative analog power supply pin (VA-), a digital power supply pin (VD), and a ground pin (GND).

For proper operation, power must be supplied to all power supply pins, and the ground pin must be connected to system ground. The CS5373A digital power supply (VD) and the CS5378 digital power supply (VDDPAD) must share a common power supply voltage.

9.1 Power Supply Bypassing

The VA+, VA-, and VD power supplies should be bypassed to system ground with 0.1 μF capacitors placed as close as possible to the power pins of the device. In addition to the 0.1 μF local bypass capacitors, at least 100 μF bulk capacitance to system ground should be placed on each power supply near the voltage regulator output, with additional power supply bulk capacitance placed among the analog component route if space permits. Bypass capacitors should be X7R, C0G, tantalum, or other high-quality dielectric type.

9.2 PCB Layers and Routing

The CS5373A is a high-performance device, and special care must be taken to ensure power and ground routing is correct. Power can be supplied either through dedicated power planes or routed traces. When routing power traces, it is recommended to use a “star” routing

scheme with the star point either at the voltage regulator output or at a local power supply bulk capacitor.

It is also recommended to dedicate a full PCB layer to a solid ground plane, without splits or routing. All bypass capacitors should connect between the power supply circuit and the solid ground plane as near as possible to the device power supply pins.

The CS5373A analog signals are differentially routed and do not normally require connection to a separate analog ground. However, if a separate analog ground is required, it should be routed using a “star” routing scheme on a separate layer from the solid ground plane and connected to the ground plane only at the star point. Be sure all active devices and passive components connected to the analog ground are included in the “star” route to ensure sensitive analog currents do not return through the ground plane.

9.3 Power Supply Rejection

Power supply rejection of the CS5373A is frequency dependent. The CS5378 digital filter rejects power supply noise for frequencies above the selected digital filter corner frequency. Power supply noise frequencies between DC and the digital filter corner frequency are rejected as specified in the [Power Supply Characteristics](#) table.

9.4 SCR Latch-up

The VA- pin is tied to the CS5373A CMOS substrate and must always be the most-negative voltage applied to the device to ensure SCR latch-up does not occur. In general, latch-up may occur when any pin voltage exceeds the limits specified in the [Absolute Maximum Ratings](#) table.

It is recommended to connect the VA- power supply to system ground (GND) with a reverse-biased Schottky diode. At power up, if the VA+ power supply ramps before the VA- supply is established, the VA- pin voltage could be pulled above ground potential through the CS5373A device. If the VA- supply is pulled 0.7 V or more above GND, SCR latch-up can occur. A reverse-biased Schottky diode will clamp the VA- voltage a maximum of 0.3 V above ground to ensure SCR latch-up does not occur at power up.

9.5 DC-DC Converters

Many low-frequency measurement systems are battery powered and utilize DC-DC con-

verters to efficiently generate power supply voltages. To minimize interference effects, operate the DC-DC converter at a frequency which is rejected by the digital filter, or operate it synchronous to the MCLK rate.

A synchronous DC-DC converter whose operating frequency is derived from MCLK will theoretically minimize the potential for “beat frequencies” to appear in the measurement bandwidth. However this requires the source clock to remain jitter-free within the DC-DC converter circuitry. If clock jitter can occur within the DC-DC converter (as in a PLL-based architecture), it’s better to use a non-synchronous DC-DC converter whose switching frequency is rejected by the digital filter.

During PCB layout, do not place high-current DC-DC converters near sensitive analog components. Carefully routing a separate DC-DC “star” ground will help isolate noisy switching currents away from the sensitive analog components.

10. TERMINOLOGY

- **Signal-to-Noise Ratio (Dynamic Range)** - Ratio of the rms magnitude of the full-scale signal to the integrated rms noise from DC to 430 Hz. The following formula is used to calculate SNR:

$$SNR = 20\log \left(\frac{\text{rms magnitude of full scale signal}}{\text{rms magnitude of noise floor}} \right)$$

- **Total Harmonic Distortion** - Ratio of the power of the fundamental frequency to the sum of the powers of all harmonic frequencies from DC to 430 Hz. The following formula is used to calculate THD:

$$THD = 10\log \left(\frac{\text{sum of the powers of the harmonic frequencies}}{\text{power of the fundamental frequency}} \right)$$

- **Full-scale Bandwidth** - The bandwidth in which the converter can generate a full-scale signal while maintaining performance specifications.
- **Impulse Amplitude** - The maximum amplitude of the output signal beyond the full-scale bandwidth.
- **Differential Output Level** - The voltage between the analog output pins of the device.
- **Full-scale Accuracy** - Variation in the measured output voltage from the theoretical full-scale output voltage at 1x attenuation. The following formula is used to calculate full-scale accuracy:

$$\text{full scale accuracy} = \left| \left(\frac{\text{measured full scale voltage} - \text{theoretical full scale voltage}}{\text{theoretical full scale voltage}} \right) \cdot 100\% \right|$$

- **Relative Accuracy** - Variation in the measured output voltage from the theoretical attenuated output voltage at each of the attenuation ranges. The following formula is used to calculate relative accuracy:

$$\text{relative accuracy} = \left| \left(\frac{\text{measured attenuated voltage} - \text{theoretical attenuated voltage}}{\text{theoretical attenuated voltage (relative to the measured full scale voltage)}} \right) \cdot 100\% \right|$$

- **Full Scale Drift** - The variation of the measured full-scale voltage across the specified temperature range.
- **Common Mode Drift** - The variation in the measured common mode voltage across the specified temperature range.

11. PIN DESCRIPTION

Positive Capacitor Output	CAP+	1 •	28	GND	System Ground
Negative Capacitor Output	CAP-	2	27	MODE0	Mode Select
Positive Buffered Output	BUF+	3	26	MODE1	Mode Select
Negative Buffered Output	BUF-	4	25	MODE2	Mode Select
Positive High Precision Output	OUT+	5	24	ATT0	Attenuation Range Select
Negative High Precision Output	OUT-	6	23	ATT1	Attenuation Range Select
Positive Analog Power Supply	VA+	7	22	ATT2	Attenuation Range Select
Negative Analog Power Supply	VA-	8	21	TDATA	Test Bit Stream Input
Negative Voltage Reference	VREF-	9	20	VD	Positive Digital Power Supply
Positive Voltage Reference	VREF+	10	19	GND	System Ground
Positive Analog Rough Input	INR+	11	18	MCLK	Master Clock Input
Positive Analog Fine Input	INF+	12	17	MSYNC	Master Sync Input
Negative Analog Fine Input	INF-	13	16	MDATA	Modulator Data Output
Negative Analog Rough Input	INR-	14	15	MFLAG	Modulator Over-range Indicator

Pin Name	Pin #	I/O	Pin Description
CAP+, CAP-	1 2	O	Capacitor connection for internal anti-alias filter.
BUF+, BUF-	3 4	O	Buffered differential analog output.
OUT+, OUT-	5 6	O	Precision differential analog output.
VA+, VA-	7 8		Analog power supply. Refer to the Specified Operating Conditions.
VREF-, VREF+	9 10	I	Voltage reference input. Refer to the Specified Operating Conditions.
INR+, INF+	11 12	I	Analog differential rough and fine + inputs. From the + half of the differential anti-alias filter.
INF-, INR-,	13 14	I	Analog differential rough and fine - inputs. From the - half of the differential anti-alias filter.
MFLAG	15	O	Amplitude overload indicator flag.
MDATA	16	O	Oversampled $\Delta\Sigma$ bit stream conversion output.
MSYNC	17	I	Master sync input. Low to high transition resets the internal clock phasing.
MCLK	18	I	Master clock input. CMOS compatible clock input.
GND	19		System ground.
VD	20		Digital power supply. Refer to the Specified Operating Conditions.
TDATA	21	I	Test Bit Stream input from digital filter TBS generator.

Pin Name	Pin #	I/O	Pin Description																																								
ATT2, ATT1, ATTO	22, 23, 24	I	Attenuation Range. Selects the output attenuation range. <table border="1" data-bbox="408 504 1078 882" style="margin-left: 20px;"> <thead> <tr> <th colspan="4">Attenuation</th> </tr> <tr> <th>Selection</th> <th>ATT[2:0]</th> <th>Attenuation</th> <th>dB</th> </tr> </thead> <tbody> <tr> <td>0</td> <td>0 0 0</td> <td>1/1</td> <td>0 dB</td> </tr> <tr> <td>1</td> <td>0 0 1</td> <td>1/2</td> <td>-6.02 dB</td> </tr> <tr> <td>2</td> <td>0 1 0</td> <td>1/4</td> <td>-12.04 dB</td> </tr> <tr> <td>3</td> <td>0 1 1</td> <td>1/8</td> <td>-18.06 dB</td> </tr> <tr> <td>4</td> <td>1 0 0</td> <td>1/16</td> <td>-24.08 dB</td> </tr> <tr> <td>5</td> <td>1 0 1</td> <td>1/32</td> <td>-30.10 dB</td> </tr> <tr> <td>6</td> <td>1 1 0</td> <td>1/64</td> <td>-36.12 dB</td> </tr> <tr> <td>7</td> <td>1 1 1</td> <td>reserved</td> <td>reserved</td> </tr> </tbody> </table>	Attenuation				Selection	ATT[2:0]	Attenuation	dB	0	0 0 0	1/1	0 dB	1	0 0 1	1/2	-6.02 dB	2	0 1 0	1/4	-12.04 dB	3	0 1 1	1/8	-18.06 dB	4	1 0 0	1/16	-24.08 dB	5	1 0 1	1/32	-30.10 dB	6	1 1 0	1/64	-36.12 dB	7	1 1 1	reserved	reserved
Attenuation																																											
Selection	ATT[2:0]	Attenuation	dB																																								
0	0 0 0	1/1	0 dB																																								
1	0 0 1	1/2	-6.02 dB																																								
2	0 1 0	1/4	-12.04 dB																																								
3	0 1 1	1/8	-18.06 dB																																								
4	1 0 0	1/16	-24.08 dB																																								
5	1 0 1	1/32	-30.10 dB																																								
6	1 1 0	1/64	-36.12 dB																																								
7	1 1 1	reserved	reserved																																								
MODE2, MODE1, MODE0	25, 26, 27	I	Mode Selection. Determines the operational mode of the device. <table border="1" data-bbox="405 1023 1094 1704" style="margin-left: 20px;"> <thead> <tr> <th colspan="3">Modes of Operation</th> </tr> <tr> <th>Selection</th> <th>MODE[2:0]</th> <th>Mode Description</th> </tr> </thead> <tbody> <tr> <td>0</td> <td>0 0 0</td> <td>Modulator: enabled. DAC: sleep.</td> </tr> <tr> <td>1</td> <td>0 0 1</td> <td>Modulator: enabled. DAC: AC OUT and BUF outputs.</td> </tr> <tr> <td>2</td> <td>0 1 0</td> <td>Modulator: enabled. DAC: AC OUT only, BUF high-z.</td> </tr> <tr> <td>3</td> <td>0 1 1</td> <td>Modulator: enabled. DAC: AC BUF only, OUT high-z.</td> </tr> <tr> <td>4</td> <td>1 0 0</td> <td>Modulator: enabled. DAC: DC common mode output.</td> </tr> <tr> <td>5</td> <td>1 0 1</td> <td>Modulator: enabled. DAC: DC differential output.</td> </tr> <tr> <td>6</td> <td>1 1 0</td> <td>Modulator: enabled. DAC: AC common mode output.</td> </tr> <tr> <td>7</td> <td>1 1 1</td> <td>Modulator: sleep. DAC: sleep.</td> </tr> </tbody> </table>	Modes of Operation			Selection	MODE[2:0]	Mode Description	0	0 0 0	Modulator: enabled. DAC: sleep.	1	0 0 1	Modulator: enabled. DAC: AC OUT and BUF outputs.	2	0 1 0	Modulator: enabled. DAC: AC OUT only, BUF high-z.	3	0 1 1	Modulator: enabled. DAC: AC BUF only, OUT high-z.	4	1 0 0	Modulator: enabled. DAC: DC common mode output.	5	1 0 1	Modulator: enabled. DAC: DC differential output.	6	1 1 0	Modulator: enabled. DAC: AC common mode output.	7	1 1 1	Modulator: sleep. DAC: sleep.										
Modes of Operation																																											
Selection	MODE[2:0]	Mode Description																																									
0	0 0 0	Modulator: enabled. DAC: sleep.																																									
1	0 0 1	Modulator: enabled. DAC: AC OUT and BUF outputs.																																									
2	0 1 0	Modulator: enabled. DAC: AC OUT only, BUF high-z.																																									
3	0 1 1	Modulator: enabled. DAC: AC BUF only, OUT high-z.																																									
4	1 0 0	Modulator: enabled. DAC: DC common mode output.																																									
5	1 0 1	Modulator: enabled. DAC: DC differential output.																																									
6	1 1 0	Modulator: enabled. DAC: AC common mode output.																																									
7	1 1 1	Modulator: sleep. DAC: sleep.																																									
GND	28		System ground.																																								

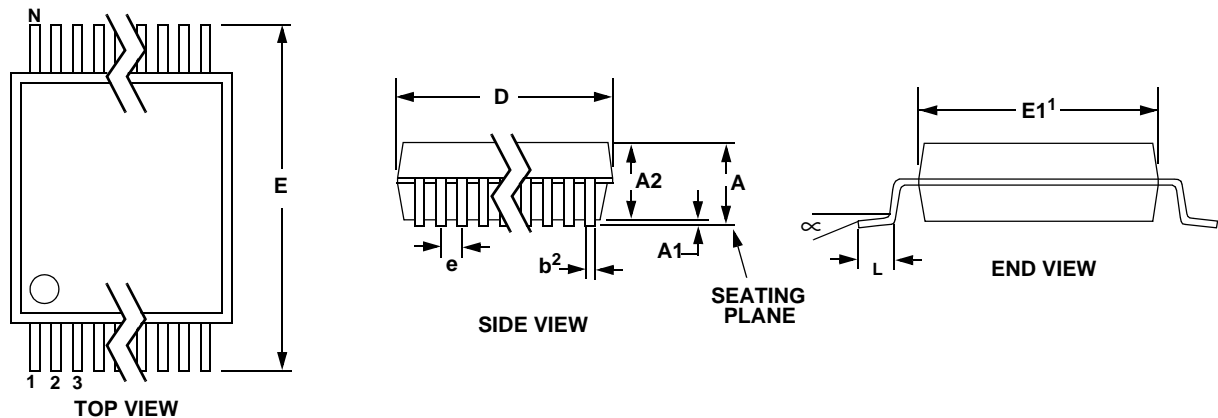
12. PACKAGE DIMENSIONS
28L SSOP PACKAGE DRAWING

DIM	INCHES			MILLIMETERS			NOTE
	MIN	NOM	MAX	MIN	NOM	MAX	
A	--	--	0.084	--	--	2.13	
A1	0.002	0.006	0.010	0.05	0.15	0.25	
A2	0.064	0.069	0.074	1.62	1.75	1.88	
b	0.009	--	0.015	0.22	--	0.38	2,3
D	0.390	0.4015	0.413	9.90	10.20	10.50	1
E	0.291	0.307	0.323	7.40	7.80	8.20	
E1	0.197	0.209	0.220	5.00	5.30	5.60	1
e	0.022	0.026	0.030	0.55	0.65	0.75	
L	0.025	0.0354	0.041	0.63	0.90	1.03	
∞	0°	4°	8°	0°	4°	8°	

JEDEC #: MO-150

Controlling Dimension is Millimeters

- Notes:
1. "D" and "E1" are reference datums and do not include mold flash or protrusions, but do include mold mismatch and are measured at the parting line, mold flash or protrusions shall not exceed 0.20 mm per side.
 2. Dimension "b" does not include dambar protrusion/intrusion. Allowable dambar protrusion shall be 0.13 mm total in excess of "b" dimension at maximum material condition. Dambar intrusion shall not reduce dimension "b" by more than 0.07 mm at least material condition.
 3. These dimensions apply to the flat section of the lead between 0.10 and 0.25 mm from lead tips.

13.ORDERING INFORMATION

Model	Temperature	Package
CS5373A-ISZ (lead free)	-40 to +85 °C	28-pin SSOP

14.ENVIRONMENTAL, MANUFACTURING, & HANDLING INFORMATION

Model Number	Peak Reflow Temp	MSL Rating*	Max Floor Life
CS5373A-ISZ (lead free)	260 °C	3	7 Days

* MSL (Moisture Sensitivity Level) as specified by IPC/JEDEC J-STD-020.

15. REVISION HISTORY

Revision	Date	Changes
PP1	NOV 2005	Preliminary release for CS5373A.
PP2	NOV 2005	Correct voltage units of full-scale DC differential output and common mode AC output at 1/4 attenuation. Add T_{data} timing to Figure 5. Correct bypass capacitor sizes in Figure 8. Correct definition of pin 28 in Pin Description table.
F1	DEC 2006	Updated to final status with most-recent characterization data for Cirrus QPL process.

Contacting Cirrus Logic Support

For all product questions and inquiries contact a Cirrus Logic Sales Representative.

To find the one nearest to you go to www.cirrus.com

IMPORTANT NOTICE

Cirrus Logic, Inc. and its subsidiaries ("Cirrus") believe that the information contained in this document is accurate and reliable. However, the information is subject to change without notice and is provided "AS IS" without warranty of any kind (express or implied). Customers are advised to obtain the latest version of relevant information to verify, before placing orders, that information being relied on is current and complete. All products are sold subject to the terms and conditions of sale supplied at the time of order acknowledgment, including those pertaining to warranty, indemnification, and limitation of liability. No responsibility is assumed by Cirrus for the use of this information, including use of this information as the basis for manufacture or sale of any items, or for infringement of patents or other rights of third parties. This document is the property of Cirrus and by furnishing this information, Cirrus grants no license, express or implied under any patents, mask work rights, copyrights, trademarks, trade secrets or other intellectual property rights. Cirrus owns the copyrights associated with the information contained herein and gives consent for copies to be made of the information only for use within your organization with respect to Cirrus integrated circuits or other products of Cirrus. This consent does not extend to other copying such as copying for general distribution, advertising or promotional purposes, or for creating any work for resale.

CERTAIN APPLICATIONS USING SEMICONDUCTOR PRODUCTS MAY INVOLVE POTENTIAL RISKS OF DEATH, PERSONAL INJURY, OR SEVERE PROPERTY OR ENVIRONMENTAL DAMAGE ("CRITICAL APPLICATIONS"). CIRRUS PRODUCTS ARE NOT DESIGNED, AUTHORIZED OR WARRANTED FOR USE IN AIRCRAFT SYSTEMS, MILITARY APPLICATIONS, PRODUCTS SURGICALLY IMPLANTED INTO THE BODY, AUTOMOTIVE SAFETY OR SECURITY DEVICES, LIFE SUPPORT PRODUCTS OR OTHER CRITICAL APPLICATIONS. INCLUSION OF CIRRUS PRODUCTS IN SUCH APPLICATIONS IS UNDERSTOOD TO BE FULLY AT THE CUSTOMER'S RISK AND CIRRUS DISCLAIMS AND MAKES NO WARRANTY, EXPRESS, STATUTORY OR IMPLIED, INCLUDING THE IMPLIED WARRANTIES OF MERCHANTABILITY AND FITNESS FOR PARTICULAR PURPOSE, WITH REGARD TO ANY CIRRUS PRODUCT THAT IS USED IN SUCH A MANNER. IF THE CUSTOMER OR CUSTOMER'S CUSTOMER USES OR PERMITS THE USE OF CIRRUS PRODUCTS IN CRITICAL APPLICATIONS, CUSTOMER AGREES, BY SUCH USE, TO FULLY INDEMNIFY CIRRUS, ITS OFFICERS, DIRECTORS, EMPLOYEES, DISTRIBUTORS AND OTHER AGENTS FROM ANY AND ALL LIABILITY, INCLUDING ATTORNEYS' FEES AND COSTS, THAT MAY RESULT FROM OR ARISE IN CONNECTION WITH THESE USES.

Cirrus Logic, Cirrus, and the Cirrus Logic logo designs are trademarks of Cirrus Logic, Inc. All other brand and product names in this document may be trademarks or service marks of their respective owners.