

PLEASE CHECK WWW.MOLEX.COM FOR LATEST PART INFORMATION

Part Number: **0191930348**
Status: **Active**
Description: VersaKrimp™ Ring Tongue Terminal for 2/0 AWG Wire

Documents:

[Drawing \(PDF\)](#) [RoHS Certificate of Compliance \(PDF\)](#)

Agency Certification

CSA LR18689
 UL E32244

General

Product Family Ring and Spade Terminals
 Series [19193](#)
 Comments Type I Noninsulated; Class 2
 Crimp Quality Equipment Yes
 Mil-Spec AS20659-154, MS20659-154
 Product Name VersaKrimp™
 Type Ring

Physical

Barrel Type Closed - Brazed
 Insulation None
 Material - Plating Mating Tin
 Packaging Type Bag
 Plating min: Mating (µin) 100
 Plating min: Mating (µm) 2.5
 Plating min: Termination (µin) 100
 Plating min: Termination (µm) 2.5
 Stud Size 7/16" (M11)
 Termination Interface: Style Crimp or Compression
 Wire Size AWG 2/0

Material Info

Old Part Number J-385-76

Reference - Drawing Numbers

Sales Drawing SD-19193-009

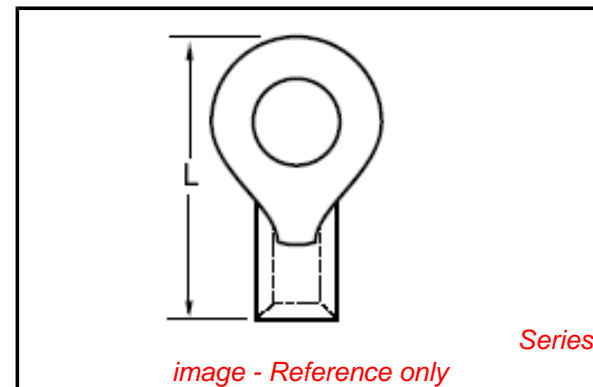

image - Reference only

EU RoHS

**ELV and RoHS
 Compliant**

REACH SVHC

**Contains SVHC: No
 Halogen-Free**

Status

Halogen-Free

China RoHS



**Need more information on product
 environmental compliance?**

Email productcompliance@molex.com
 For a multiple part number RoHS Certificate of
 Compliance, [click here](#)

Please visit the [Contact Us](#) section for any
 non-product compliance questions.

Search Parts in this Series

[19193Series](#)

Application Tooling | [FAQ](#)

*Tooling specifications and manuals are
 found by selecting the products below.
 Crimp Height Specifications are then
 contained in the Application Tooling
 Specification document.*

Global

Description	Product #
Putt Pump Dieless Head System	0192860065
Manual Putt Pump Hydraulic System, Die set required	0192860117
Die Set (large) for the HHLS Hydraulic Crimper	0192900012

MATERIAL NO. LOOSE PIECE	ENG. NO.	STUD SIZE	±.003 *S*	STOCK THICKNESS
191930342	J-385-14	1/4	.265	.083 (2.11)
191930346	J-385-56	5/16	.328	
191930345	J-385-38	3/8	.390	
191930348	J-385-76	7/16	.453	
191930341	J-385-12	1/2	.515	

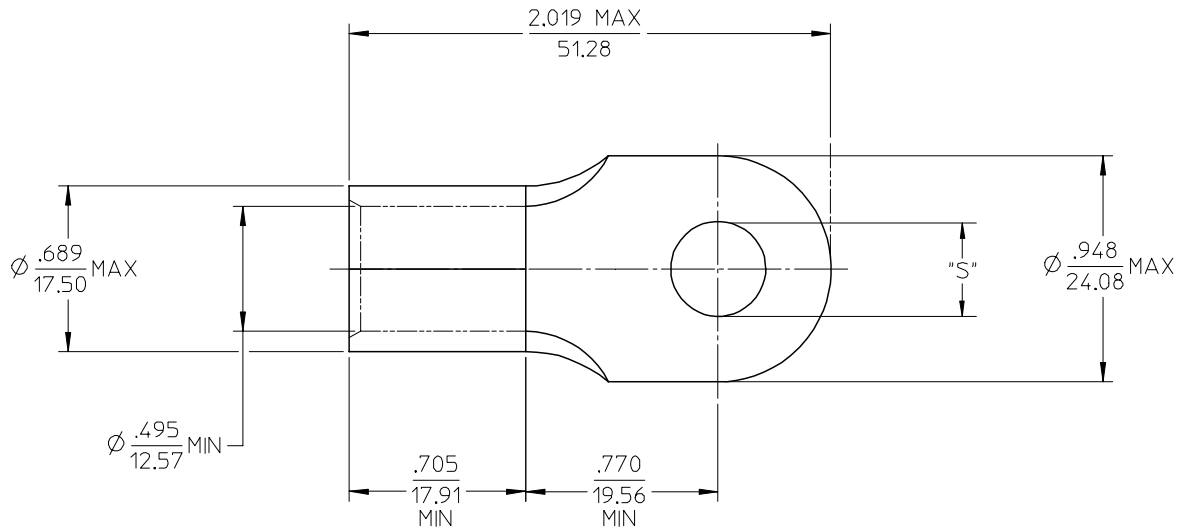

SALES DRAWING

NOTE(S):
 1. MATERIAL: COPPER
 2. PLATING: ELECTROPLATE TIN
 3. ALL DIMENSIONS IN INCHES/(MM).
 4. WIRE SIZE: 2/0 AWG
 70 MM²

REVISED/UPDATE TO MX STDS EC NO: ETC2003-0315 DRWN:DMYRICK 2003/08/20 CHKD:HEB 2003/08/21 APPR:RDEROSS 2003/08/21	DESCRIPTION REV	QUALITY SYMBOLS	GENERAL TOLERANCES (UNLESS SPECIFIED)	SCALE 2:1	DESIGN UNITS INCH	THIRD ANGLE PROJECTION	REVISE ON CAD ONLY													
		▽ = 0 □ = 0	<table border="1"> <thead> <tr> <th></th> <th>mm</th> <th>INCH</th> </tr> </thead> <tbody> <tr> <td>4 PLACES</td> <td>± .---</td> <td>± .---</td> </tr> <tr> <td>3 PLACES</td> <td>± .---</td> <td>± .005</td> </tr> <tr> <td>2 PLACES</td> <td>± 0.13</td> <td>± .01</td> </tr> <tr> <td>1 PLACE</td> <td>± 0.25</td> <td>± .---</td> </tr> </tbody> </table> ANGULAR ±1/2°		mm	INCH	4 PLACES	± .---	± .---	3 PLACES	± .---	± .005	2 PLACES	± 0.13	± .01	1 PLACE	± 0.25	± .---	DIMENSION STYLE IN/MM	TITLE RING TONGUE TERMINAL VERSAKRIMP 2/0 AWG
			mm	INCH																
		4 PLACES	± .---	± .---																
3 PLACES	± .---	± .005																		
2 PLACES	± 0.13	± .01																		
1 PLACE	± 0.25	± .---																		
	DRAFT WHERE APPLICABLE MUST REMAIN WITHIN DIMENSIONS	DRAWN BY DLM	DATE 03/06/13	CHECKED BY HEB	DATE 03/06/13	MATERIAL NO. (SEE CHART)	DOCUMENT NO. SD-19193-009	SHEET NO. 1 OF 1												
				THIS DRAWING CONTAINS INFORMATION THAT IS PROPRIETARY TO MOLEX INCORPORATED AND SHOULD NOT BE USED WITHOUT WRITTEN PERMISSION																