

**SAMSUNG**

**ELECTRONICS**

SEC Confidential

Preliminary

液晶之友 电话: 020-33819057  
Http://www.lcdfriends.com

TO : General.

DATE : July. 29. 2003

**SAMSUNG TFT-LCD**

**MODEL NO. : LTN121XJ-L02**

Notes :

Any Modification of Spec is not allowed without SEC permission

APPROVED BY :

*K. H. Shin*

PREPARED BY : **Application Engineering Team**

**SAMSUNG ELECTRONICS CO., LTD.**

**wise  
view™**

Doc.No.

LTN121XJ-L02

Rev.No

04 - P00 - G - 030729

Page

1 /23

## CONTENTS

Revision History	----- ( 3 )
General Description	----- ( 4 )
1. Absolute Maximum Ratings	----- ( 5 )
1.1 Absolute Ratings Of Environment	
1.2 Electrical Absolute Ratings	
2. Optical Characteristics	----- ( 7 )
3. Electrical Characteristics	----- ( 10 )
3.1 TFT LCD Module	
3.2 Back-light Unit	
4. Block Diagram	----- ( 13 )
4.1 TFT LCD Module	
4.2 Back-light Unit	
5. Input Terminal Pin Assignment	----- ( 14 )
5.1 Input Signal & Power	
5.2 LVDS Interface	
5.3 Back-light Unit	
5.4 Timing Diagrams of LVDS For Transmitting	
5.5 Input Signals, Basic Display Colors and Gray Scale of Each Color.	
5.6 Pixel format	
6. Interface Timing	----- ( 19 )
6.1 Timing Parameters	
6.2 Timing Diagrams of interface Signal	
6.3 Power ON/OFF Sequence	
7. Outline Dimension	----- ( 21 )
8. General Precautions	----- ( 22 )

# Revision History

Confidential

Preliminary

Date	Rev.No.	Page	Summary
July,29 ,2003	P00	All	LTN121XJ-L02 MODEL IS FIRST ISSUED.

## GENERAL DESCRIPTION

### DESCRIPTION

LTN121XJ-L02 is a color active matrix TFT (Thin Film Transistor) liquid crystal display (LCD) that uses amorphous silicon TFT as a switching devices. This model is composed of a TFTLCD panel, a driver circuit and a back-light system. The resolution of a 12.1" contains 1024 x 768 pixels and can display up to 262,144 colors. 6 o'clock direction is the optimum viewing angle.

### FEATURES

- Ultra Thin and light weight
- High contrast ratio
- XGA (1024x768 pixels) resolution
- Low power consumption
- DE (Data enable) only mode.
- 3.3V LVDS Interface with 1 pixel / clock
- EDID

### APPLICATIONS

- Notebook PC and desktop monitors
- Display terminals for AV application products
- Monitors for Industrial machine
- If the usage of this product is not for PC application, but for others, please contact SEC.

### GENERAL INFORMATION

ITEM	SPECIFICATION	UNIT	NOTE
Display area	245.76(H) x 184.32(V) (12.1" diagonal)	mm	
Driver element	a-Si TFT active matrix		
Display colors	262,144	Color	
Number of pixel	1024 x 768 (XGA)	pixel	
Pixel arrangement	RGB vertical stripe		
Pixel pitch	0.240(H) x 0.240(V) (TYP.)	mm	
Display Mode	Normally white		
Surface treatment	HAZE 25, ANTIGLARE & HARD-COATING 3H		

## MECHANICAL INFORMATION

ITEM		MIN.	TYP.	MAX.	NOTE
Module size	Horizontal (H)	260.5	261.0	261.5	
	Vertical (V)	198.5	199.0	199.5	
	Depth (D)	-	4.7	5.0	(1)
Weight		-	280	290	g (with Inverter)

Note (1) Measurement condition of outline dimension  
. Equipment : Vernier Calipers  
. Push Force : 500g ·f (minimum)

## 1. ABSOLUTE MAXIMUM RATINGS

## 1.1 ABSOLUTE RATINGS OF ENVIRONMENT

ITEM	SYMBOL	MIN.	MAX.	UNIT	NOTE
Storage temperature	T <sub>STG</sub>	-25	60	°C	(1)
Operating temperature (Temperature of glass surface)	T <sub>OPR</sub>	0	50	°C	(1)
Shock ( non-operating )	Snop	-	220	G	(2),(4)
Vibration (non-operating)	Vnop	-	1.5	G	(3),(4)

Note (1) Temperature and relative humidity range are shown in the figure below.  
90 % RH Max. ( 40 °C ≥ Ta)  
Maximum wet - bulb temperature at 39 °C or less. (Ta > 40 °C ) No condensation.

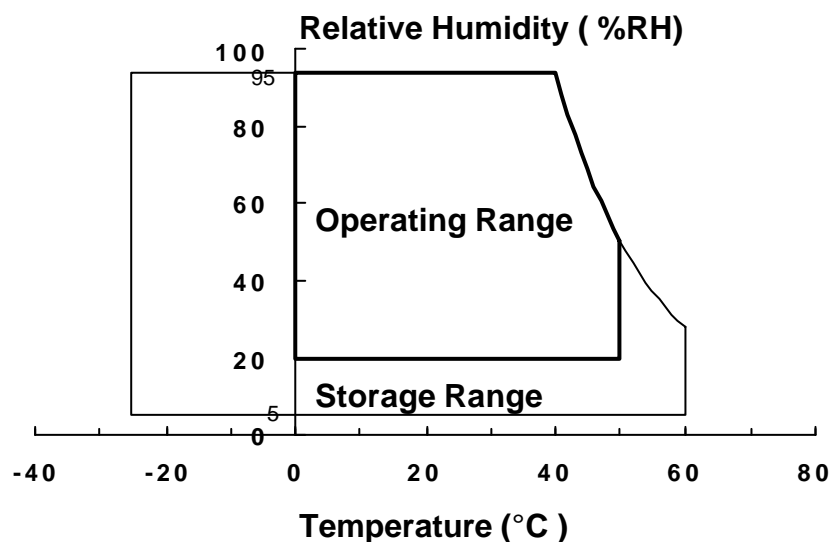

- (2) 2ms, half sine wave, one time for  $\pm X$ ,  $\pm Y$ ,  $\pm Z$ .  
(3) 10 - 300 Hz, Sweep rate 10 min, 30min for X,Y,Z.  
(4) At testing Vibration and Shock, the fixture in holding the Module to be tested have to be hard and rigid enough so that the Module would not be twisted or bent by the fixture.

## 1.2 ELECTRICAL ABSOLUTE RATINGS

## (1) TFT LCD MODULE

(V<sub>SS</sub> = GND = 0 V)

ITEM	SYMBOL	MIN.	MAX.	UNIT	NOTE
Power Supply Voltage	VDD	V <sub>SS</sub> -0.3	VDD+0.3	V	(1)
Logic Input Voltage	V <sub>IN</sub>	V <sub>SS</sub> -0.3	VDD+0.3	V	(1)

NOTE (1) Within Ta = 25 ± 2 °C

## (2) BACK-LIGHT UNIT

Ta = 25 ± 2 °C

ITEM	SYMBOL	MIN.	MAX.	UNIT.	NOTE
Lamp current	IL	2.0	6.5	mArms	(1)
Lamp frequency	FL	50	80	KHz	(1)

NOTE (1) Permanent damage to the device may occur if maximum values are exceeded.  
Functional operation should be restricted to the conditions described under Normal Operating Conditions.

## 2. OPTICAL CHARACTERISTICS

The following items are measured under stable conditions. The optical characteristics should be measured in a dark room or equivalent state with the methods shown in Note (5).

Measuring equipment : TOPCON BM-5A , PR650

\* Ta = 25 ± 2°C , VDD=3.3V, fv= 60Hz, fdCLK=65MHz, IL = 6.0mA

ITEM		SYMBOL	CONDITION	MIN.	TYP.	MAX.	UNIT	NOTE	
Contrast Ratio (5 Points)		CR	$\phi = 0,$ $\theta = 0$ Normal Viewing Angle	300	-	-		(1), (2), (5)	
Response Time at Ta	Rising	TR		-	6	10	msec	(1), (3)	
	Falling	TF		-	25	30			
Average Luminance of White (5 Points)		Y <sub>LAVE</sub>			127.5	150	-	cd/m <sup>2</sup>	(1), (4) IL = 6.0mA
Color Chromaticity ( CIE )	Red	R <sub>X</sub>			0.550	0.580	0.610		Measured by PR 650  (1), (5)
		R <sub>Y</sub>			0.310	0.340	0.370		
	Green	G <sub>X</sub>			0.280	0.310	0.340		
		G <sub>Y</sub>			0.520	0.550	0.580		
	Blue	B <sub>X</sub>			0.125	0.155	0.185		
		B <sub>Y</sub>			0.125	0.155	0.185		
	White	W <sub>X</sub>		0.283	0.313	0.343			
		W <sub>Y</sub>		0.299	0.329	0.359			
Viewing Angle	Hor.	$\theta_L$	CR( at center point) $\geq 10$	40	-	-	Degrees		
		$\theta_R$		40	-	-			
	Ver.	$\phi_H$		10	-	-			
		$\phi_L$		30	-	-			
13 Points White Variation		$\delta L$		-	-	1.65		(6)	

Note 1) Definition of Viewing Angle : Viewing angle range( $10 \leq C/R$ )

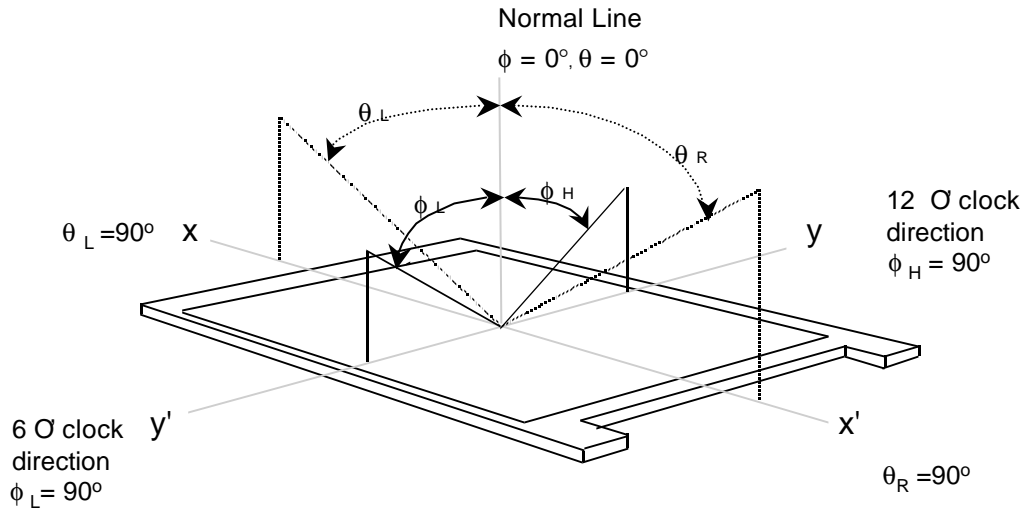

Note 2) Definition of Contrast Ratio (CR) : Ratio of gray max (Gmax), gray min (Gmin) at 5 points(4, 5, 7, 9, 10)

$$CR = \frac{CR(4) + CR(5) + CR(7) + CR(9) + CR(10)}{5}$$

POINTS : (4), (5), (7), (9), (10) at FIGURE OF NOTE 6)

Note 3) Definition of Response time :

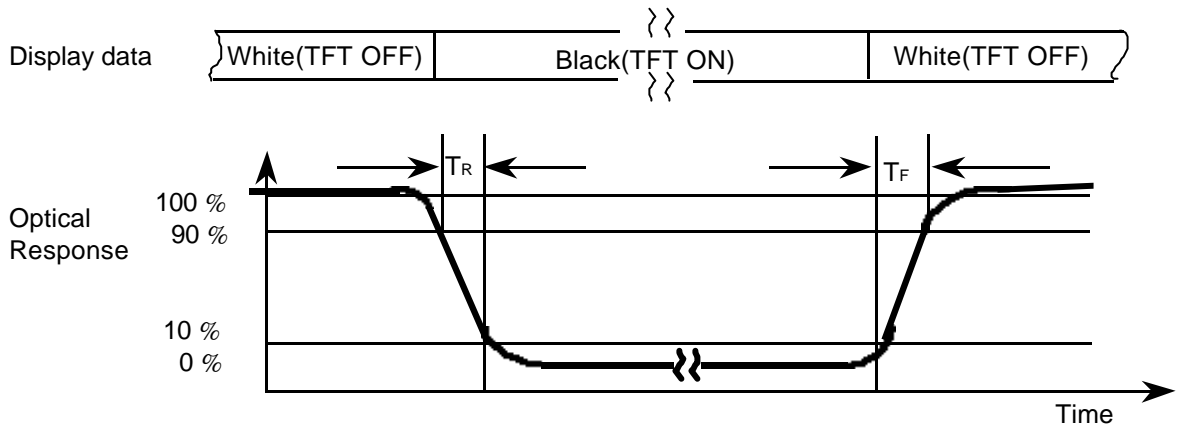

Note 4) Definition of Average Luminance of White : measure the luminance of white at 5 points.

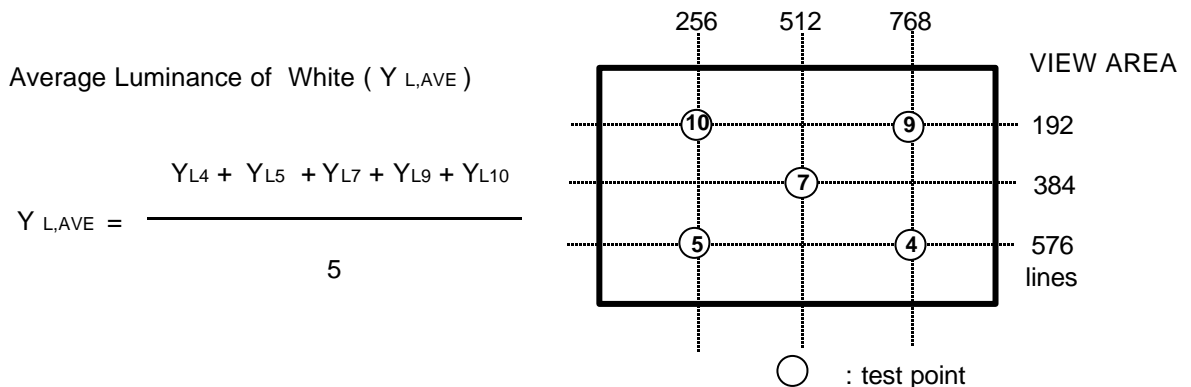



Note 5) After stabilizing and leaving the panel alone at a given temperature for 30 minutes, the measurement should be executed. Measurement should be executed in a stable, windless, and dark room. 30 minutes after lighting the back-light. This should be measured in the center of screen.  
 Lamp current : 5.0 mA  
 Environment condition :  $T_a = 25 \pm 2 \text{ }^\circ\text{C}$

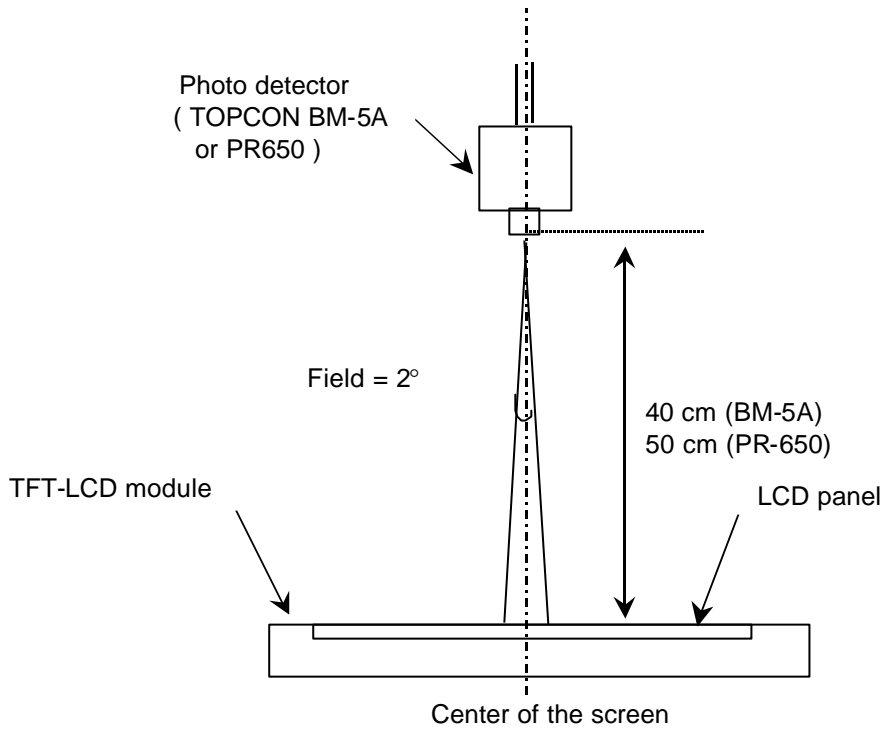

Optical characteristics measurement setup

Note 6) Definition of 13 points white variation ( $\delta_w$ ), CR variation ( $C_{VER}$ ) [ ① ~ ⑬ ]

$$\delta_L = \frac{\text{Maximum luminance of 13 points}}{\text{Minimum luminance of 13 points}}$$

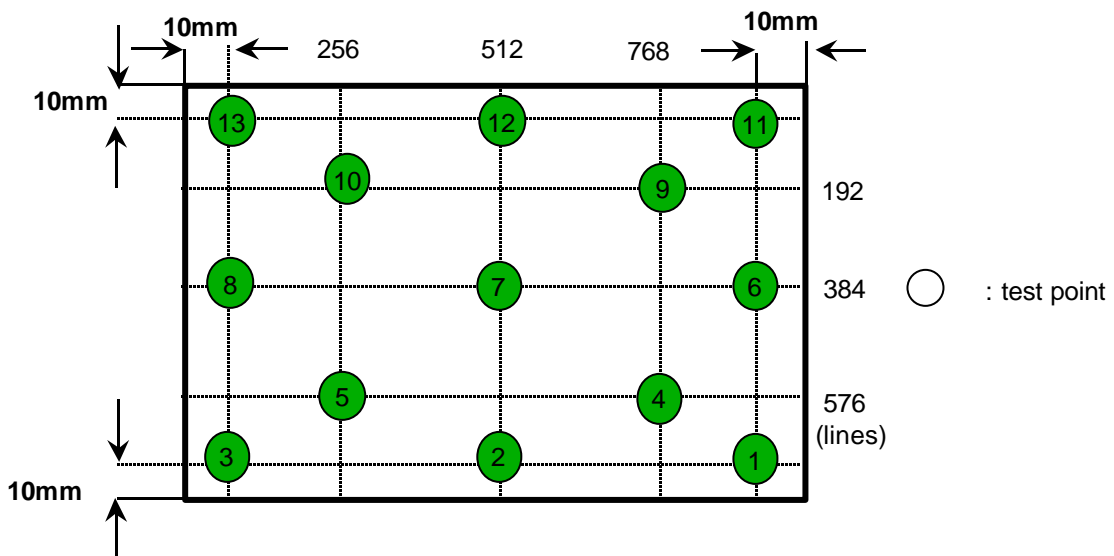

### 3. ELECTRICAL CHARACTERISTICS

#### 3.1 TFT LCD MODULE

Ta = 25 ± 2%°C

ITEM	SYMBOL	MIN	TYP	MAX	UNIT	NOTE	
Voltage of Power Supply	V <sub>DD</sub>	3.0	3.3	3.6	V		
Differential Input Voltage for LVDS Receiver Threshold	High	V <sub>IH</sub>	-	-	+100	mV	(1)
	Low	V <sub>IL</sub>	-100	-	-	mV	
Vsync Frequency	f <sub>v</sub>	-	60	-	Hz		
Hsync Frequency	f <sub>H</sub>	-	48.2	-	KHz		
Main Frequency	f <sub>DCLK</sub>	-	65	-	MHz		
Rush Current	I <sub>RUSH</sub>	-	-	1.5	A	(4)	
Current of Power Supply	White	I <sub>DD</sub>	-	265	-	mA	(2),(3)
	Mosaic		-	280	-	mA	(2),(3)
	Max.		-	340	360	mA	(2),(3)

- Note (1) Condition : V<sub>CM</sub>=+1.2V(Common mode Voltage)  
 (2) f<sub>v</sub>=60Hz, f<sub>DCLK</sub> =65MHZ, V<sub>dd</sub> = 3.3V , DC Current.  
 (3) Power dissipation check pattern

\*a) White Pattern

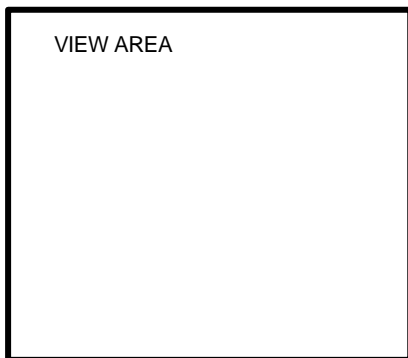

\*b)Mosaic Pattern

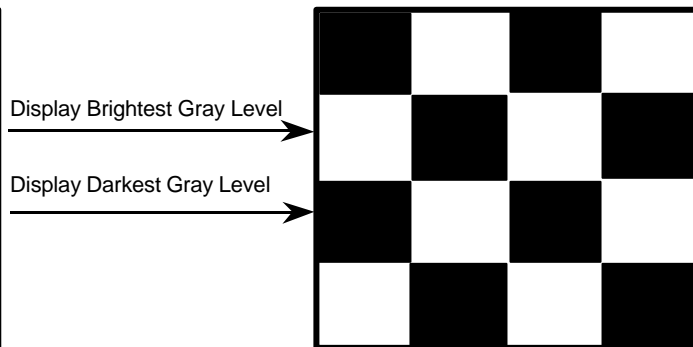

\*c) Maximum Power pattern : 1dot vertical stripe

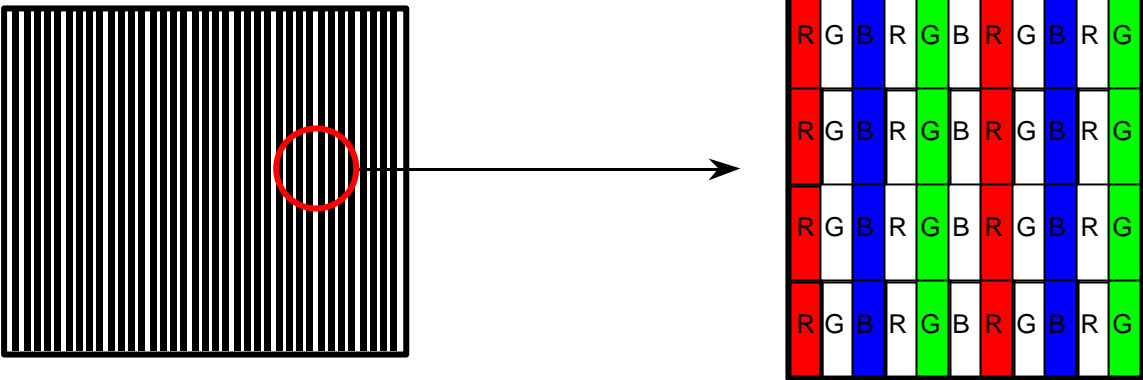

4) Rush current measurement condition

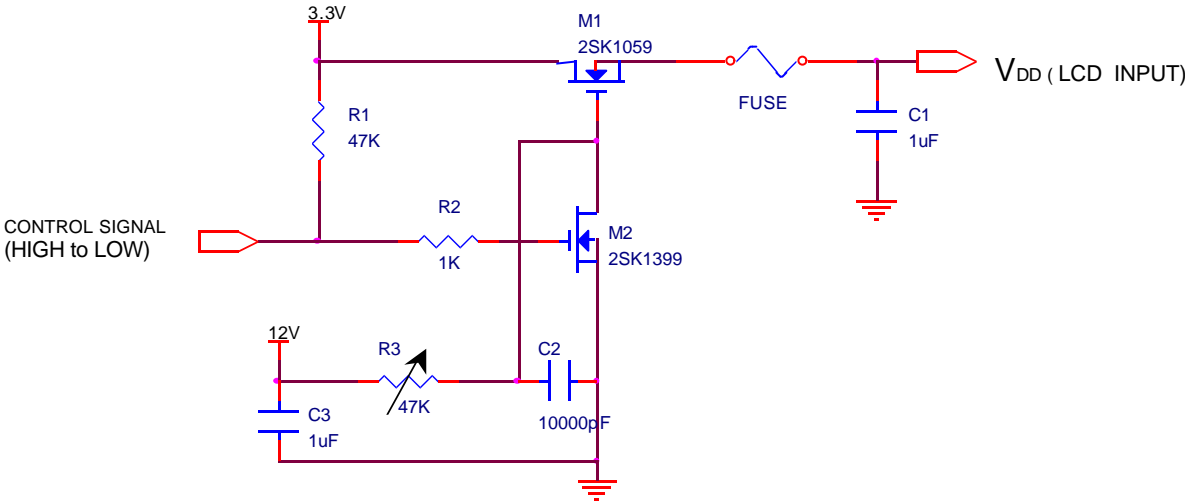

$V_{DD}$  rising time is 470us

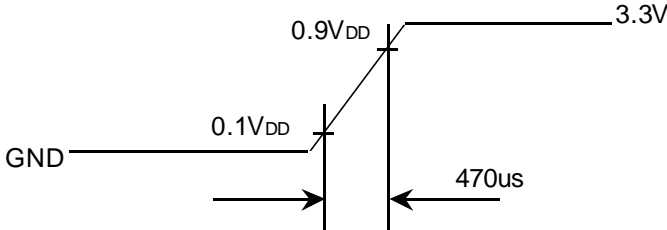

### 3.2 BACKLIGHT UNIT

The back-light system is an edge - lighting type with a single CCFT ( Cold Cathode Fluorescent Tube ). The characteristics of a single lamp are shown in the following tables.

INVERTER :

Ta = 25 ± 2°C

ITEM	SYMBOL	MIN	TYP	MAX	UNIT	NOTE
Lamp Current	I <sub>L</sub>	3.0	6.0	6.5	mArms	(1)
Lamp Voltage	V <sub>L</sub>	-	565	-	V <sub>rms</sub>	I <sub>L</sub> =6.0mA
Frequency	f <sub>L</sub>	50	60	80	KHz	
Power Consumption	P <sub>L</sub>	-	-	4.5	W	(2) I <sub>L</sub> =6.0mA
Operating Life Time	Hr	10,000	-	-	Hour	(3)
Startup Voltage	V <sub>s</sub>	-	-	1080 (25°C)	V <sub>rms</sub>	
				1300 (0°C)		

Note (1) Lamp current is measured with a high frequency current meter as shown below.

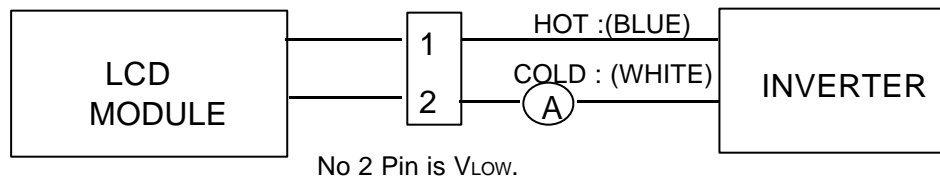

(2) The value is calculated by I<sub>L</sub> X V<sub>L</sub> when inverter' s efficient is 85%. .

(3) Life time (Hr) of a lamp can be defined as the time in which it continues to operate under the condition Ta = 25 ± 2°C and I<sub>L</sub> = 5.0 mArms until one of the following event occurs.

1. When the brightness becomes 50% or lower than it s original.
2. When the Effective ignition length becomes 80% or lower than it s original value.  
(Effective ignition length is defined as an area that has less than 70% brightness compared to the brightness in the center point.)

### 4. BLOCK DIAGRAM

#### 4.1 TFT LCD MODULE

Connector : HIROSE DF-19L20P-1H

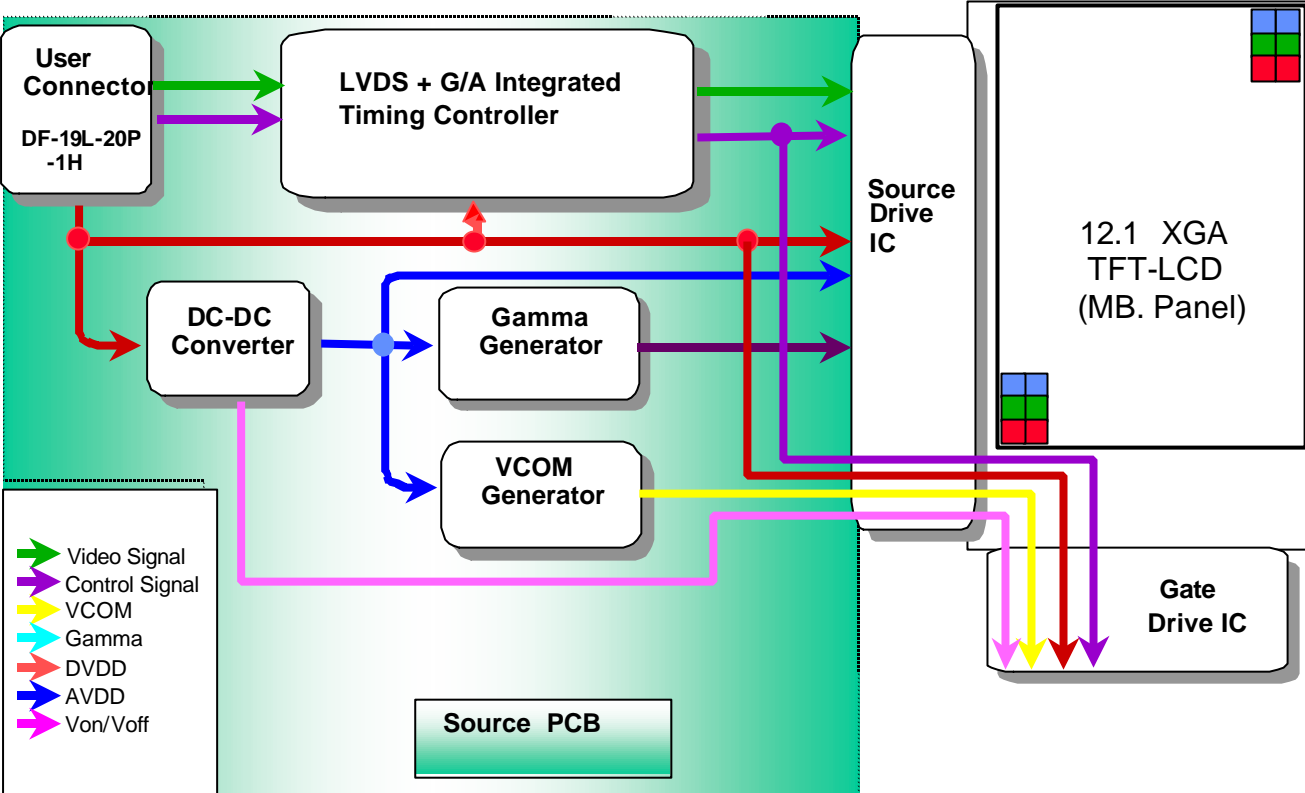

#### 4.2 BACKLIGHT UNIT

Connector : JST BHSR-02VS-01

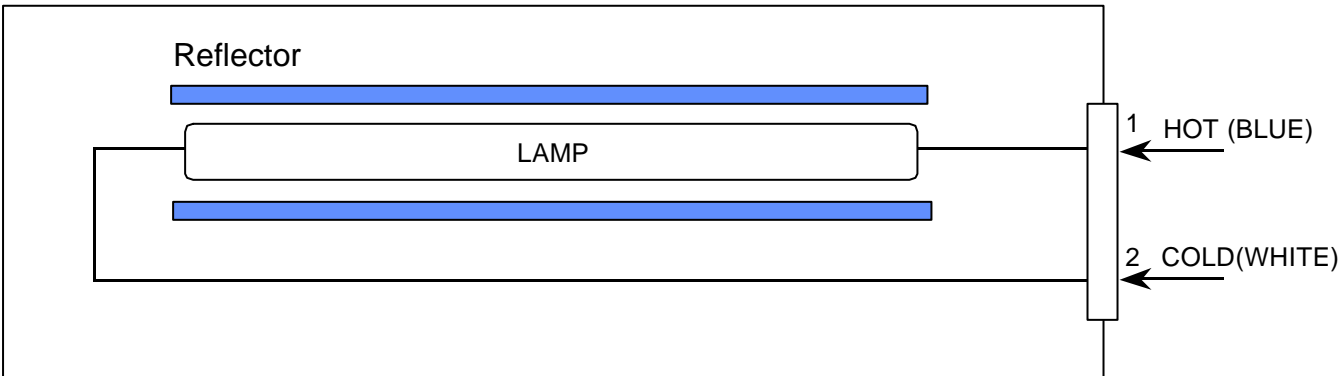

Note) The output of the inverter may change according to the material of the reflector.

## 5. INPUT TERMINAL PIN ASSIGNMENT

### 5.1. Input Signal & Power (LVDS, Connector : HIROSE DF-19L-20P-1H)

PIN NO	SYMBOL	FUNCTION	POLARITY	REMARK
1	VSS	GROUND		
2	VDD	POWER SUPPLY +3.3V		
3	VDD	POWER SUPPLY +3.3V		
4	V EEDID	DDC + 3.3V POWER		
5	NC	-		
6	Clk EEDID	DDC Clock		
7	Data EEDID	DDC Data		
8	RxIN0-	LVDS Differential Data INPUT	Negative	R0~R5 G0
9	RxIN0+	LVDS Differential Data INPUT	Positive	
10	VSS	GROUND		
11	RxIN1-	LVDS Differential Data INPUT	Negative	G1~G5 B0~B1
12	RxIN1+	LVDS Differential Data INPUT	Positive	
13	VSS	GROUND		
14	RxIN2-	LVDS Differential Data INPUT	Negative	B2~B5 HS,VS,DE
15	RxIN2+	LVDS Differential Data INPUT	Positive	
16	VSS	GROUND		
17	ClkIN-	LVDS Differential Clock INPUT	Negative	
18	ClkIN+	LVDS Differential Clock INPUT	Positive	
19	VSS	GROUND		
20	VSS	GROUND		

**5.2 LVDS Interface : Transmitter DS90CF383 or Compatible**

Pin No.	Name	RGB Signal	Pin No.	Name	RGB Signal
51	TxIN0	R0	14	TxIN14	G5
52	TxIN1	R1	15	TxIN15	B0
54	TxIN2	R2	19	TxIN18	B1
55	TxIN3	R3	20	TxIN19	B2
56	TxIN4	R4	22	TxIN20	B3
3	TxIN6	R5	23	TxIN21	B4
4	TxIN7	G0	24	TxIN22	B5
6	TxIN8	G1	27	TxIN24	Hsync
7	TxIN9	G2	28	TxIN25	Vsync
11	TxIN12	G3	30	TxIN26	DE
12	TxIN13	G4	31	TxCLKIN	Clock

**FLAT LINK INTERFACE**

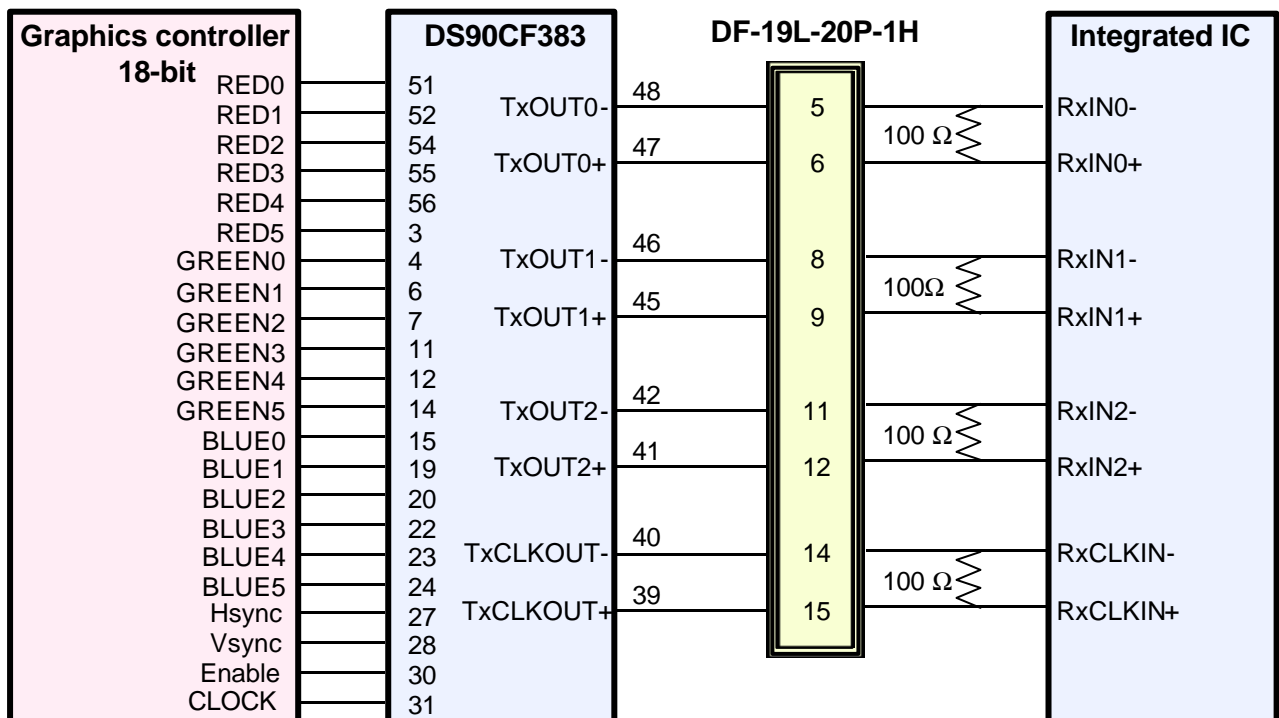

### 5.3 BACK LIGHT UNIT

Connector : JST BHSR - 02VS -1  
 Mating Connector : JST SM02B-BHSS-1

Pin NO.	Symbol	Color	Function
1	HOT	TBD	High Voltage
2	COLD	WHITE	Low Voltage

### 5.4 Timing Diagrams of LVDS For Transmission

LVDS Receiver : LXD01812(including I/F IC)

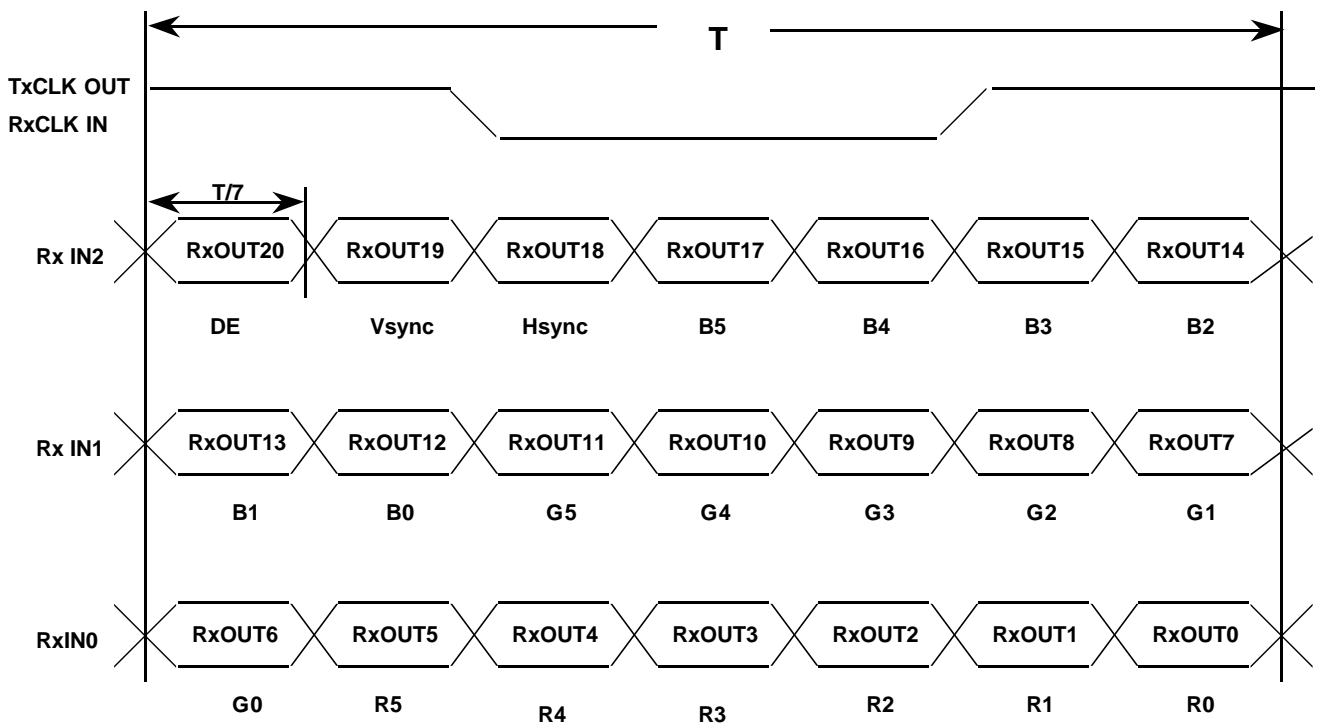



5.5 Input Signal, Basic Display Colors and Gray Scale of Each Colors

COLOR	DISPLAY	DATA SIGNAL																	GRAY SCALE LEVEL
		RED					GREEN					BLUE							
		R0	R1	R2	R3	R4	R5	G0	G1	G2	G3	G4	G5	B0	B1	B2	B3	B4	
BASIC COLOR	BLACK	0	0	0	0	0	0	0	0	0	0	0	0	0	0	0	0	0	-
	BLUE	0	0	0	0	0	0	0	0	0	0	0	0	1	1	1	1	1	-
	GREEN	0	0	0	0	0	0	1	1	1	1	1	1	0	0	0	0	0	-
	CYAN	0	0	0	0	0	0	1	1	1	1	1	1	1	1	1	1	1	-
	RED	1	1	1	1	1	1	0	0	0	0	0	0	0	0	0	0	0	-
	MAGENTA	1	1	1	1	1	1	0	0	0	0	0	0	1	1	1	1	1	-
	YELLOW	1	1	1	1	1	1	1	1	1	1	1	1	0	0	0	0	0	-
	WHITE	1	1	1	1	1	1	1	1	1	1	1	1	1	1	1	1	1	-
GRAY SCALE OF RED	BLACK	0	0	0	0	0	0	0	0	0	0	0	0	0	0	0	0	0	R0
	DARK ↑	1	0	0	0	0	0	0	0	0	0	0	0	0	0	0	0	0	R1
		0	1	0	0	0	0	0	0	0	0	0	0	0	0	0	0	0	R2
		:	:	:	:	:	:	:	:	:	:	:	:	:	:	:	:	:	R3-R60
	:	:	:	:	:	:	:	:	:	:	:	:	:	:	:	:	:		
	↓ LIGHT	1	0	1	1	1	1	0	0	0	0	0	0	0	0	0	0	0	R61
		0	1	1	1	1	1	0	0	0	0	0	0	0	0	0	0	0	R62
	RED	1	1	1	1	1	1	0	0	0	0	0	0	0	0	0	0	0	R63
GRAY SCALE OF GREEN	BLACK	0	0	0	0	0	0	0	0	0	0	0	0	0	0	0	0	0	G0
	DARK ↑	0	0	0	0	0	0	1	0	0	0	0	0	0	0	0	0	0	G1
		0	0	0	0	0	0	0	1	0	0	0	0	0	0	0	0	0	G2
		:	:	:	:	:	:	:	:	:	:	:	:	:	:	:	:	:	G3-G60
	:	:	:	:	:	:	:	:	:	:	:	:	:	:	:	:	:		
	↓ LIGHT	0	0	0	0	0	0	1	0	1	1	1	1	0	0	0	0	0	G 61
		0	0	0	0	0	0	0	1	1	1	1	1	0	0	0	0	0	G 62
	GREEN	0	0	0	0	0	0	1	1	1	1	1	1	0	0	0	0	0	G 63
GRAY SCALE OF BLUE	BLACK	0	0	0	0	0	0	0	0	0	0	0	0	0	0	0	0	0	B0
	DARK ↑	0	0	0	0	0	0	0	0	0	0	0	0	1	0	0	0	0	B1
		0	0	0	0	0	0	0	0	0	0	0	0	0	1	0	0	0	B2
		:	:	:	:	:	:	:	:	:	:	:	:	:	:	:	:	:	B3-B60
	:	:	:	:	:	:	:	:	:	:	:	:	:	:	:	:	:		
	↓ LIGHT	0	0	0	0	0	0	0	0	0	0	0	0	1	0	1	1	1	B61
		0	0	0	0	0	0	0	0	0	0	0	0	0	1	1	1	1	B62
	BLUE	0	0	0	0	0	0	0	0	0	0	0	0	1	1	1	1	1	B63

Note

(1) Definition of Gray : Rn : Red Gray, Gn : Green Gray, Bn : Blue Gray (n = Gray level)

(2) Input Signal : 0 = Low level voltage, 1 = High level voltage

5.6 PIXEL FORMAT

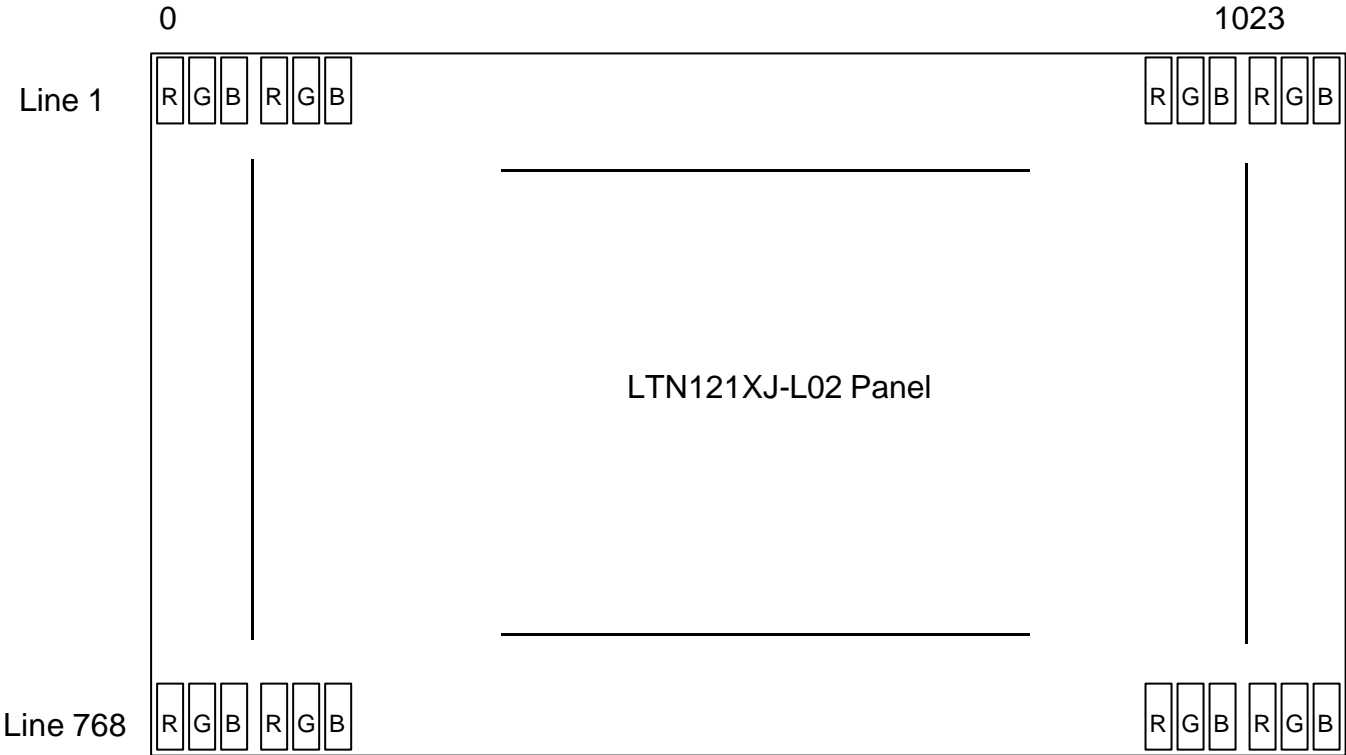

## 6. INTERFACE TIMING

### 6.1 Timing Parameters

Signal	Item	Symbol	MIN	TYP	MAX	Unit	Note
Frame Frequency	Cycle	$\text{f}$	772	806	1000	lines	
Vertical Active Display Term	Display Period	$\text{f}_d$	-	768	-	lines	
One Line Scanning Time	Cycle	$\text{f}_H$	1072	1344	1500	clocks	
Horizontal Active Display Term	Display Period	$\text{f}_{Hd}$	-	1024	-	clocks	

### 6.2 Timing diagrams of interface signal

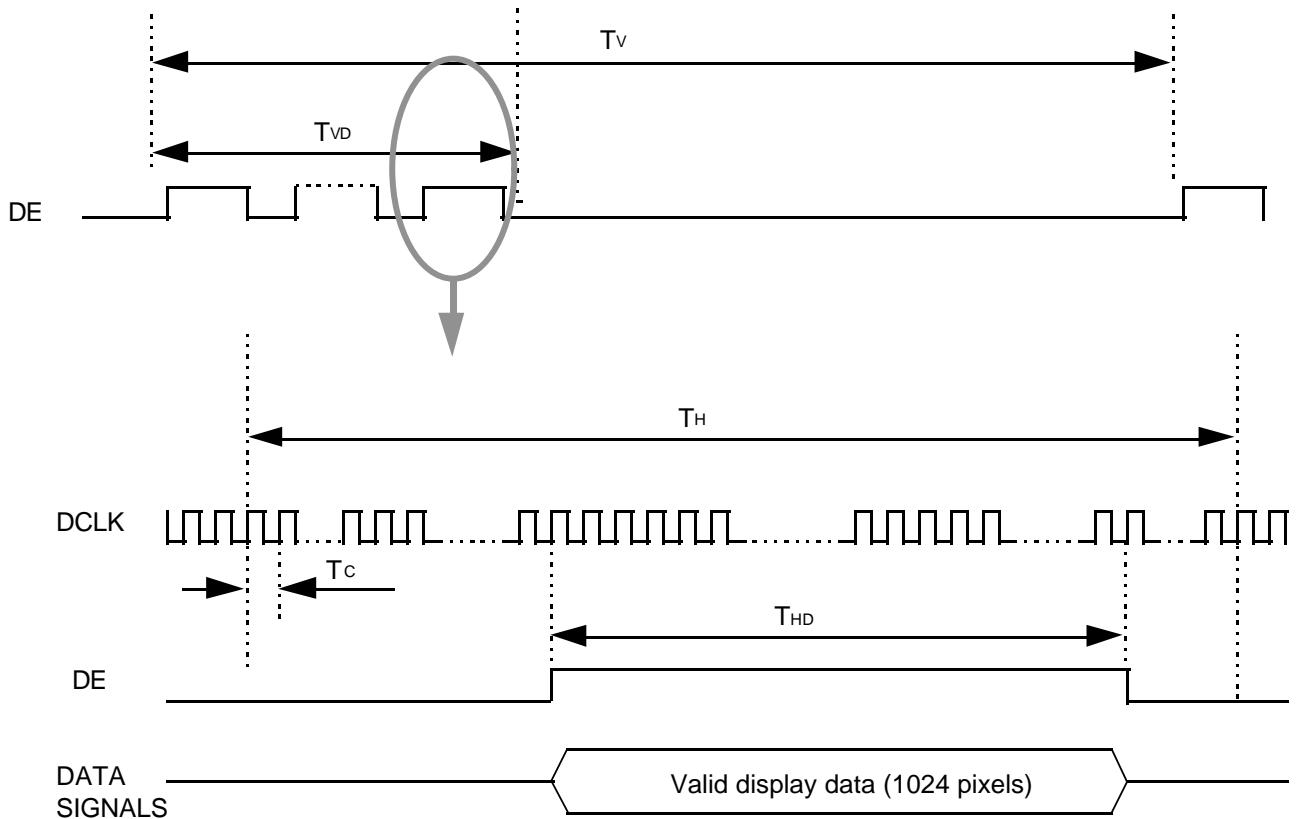

Note

(1) All input condition(level&timing) for LX D01812 are the same with those of NS DS90CF384 or compatible.

### 6.3 Power ON/OFF Sequence

: To prevent a latch-up or DC operation of the LCD module, the power on/off sequence should be as the diagram below.

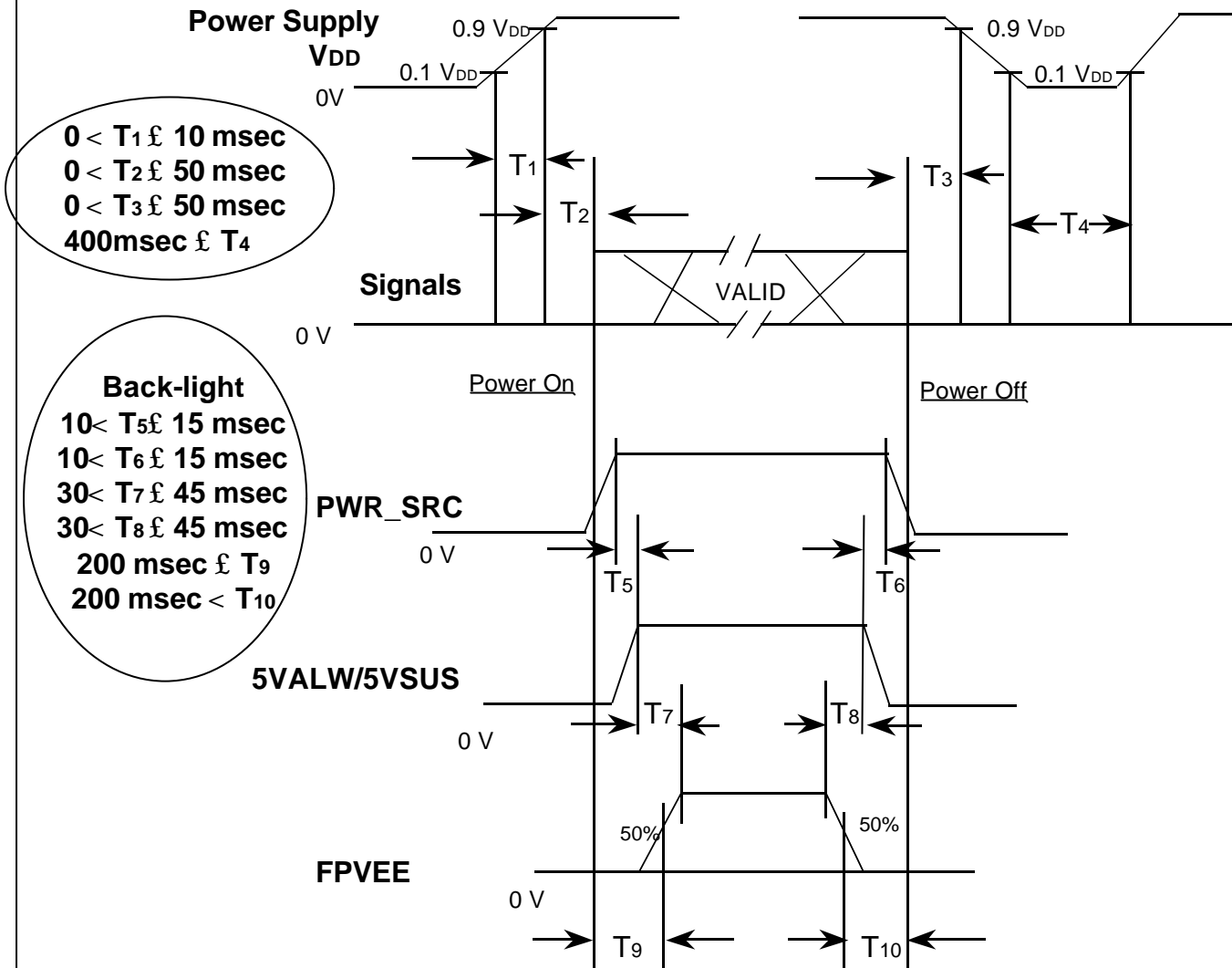

0 < T<sub>1</sub> £ 10 msec  
 0 < T<sub>2</sub> £ 50 msec  
 0 < T<sub>3</sub> £ 50 msec  
 400msec £ T<sub>4</sub>

Back-light  
 10 < T<sub>5</sub> £ 15 msec  
 10 < T<sub>6</sub> £ 15 msec  
 30 < T<sub>7</sub> £ 45 msec  
 30 < T<sub>8</sub> £ 45 msec  
 200 msec £ T<sub>9</sub>  
 200 msec < T<sub>10</sub>

- T1 : V<sub>DD</sub> rising time from 10% to 90%
- T2 : The time from V<sub>DD</sub> to valid data at power ON.
- T3 : The time from valid data off to V<sub>DD</sub> off at power Off.
- T4 : V<sub>DD</sub> off time for Windows restart
- T9 : The time from valid data to B/L enable at power ON.
- T10 : The time from valid data off to B/L disable at power Off.

NOTE.

- (1) The supply voltage of the external system for the module input should be the same as the definition of V<sub>DD</sub>.
- (2) Apply the lamp voltage within the LCD operation range. When the back-light turns on before the LCD operation or the LCD turns off before the back-light turns off, the display may momentarily become white.
- (3) In case of V<sub>DD</sub> = off level, please keep the level of input signals on the low or keep a high impedance.
- (4) T<sub>4</sub> should be measured after the module has been fully discharged between power off and on period.
- (5) Interface signal shall not be kept at high impedance when the power is on.

# 7.Outline Dimension

NO	PART NAME	CODE NO	SPECIFICATION	Q'TY	WEIGHT FINISH	MATERIAL	UNFOLDED DIM. OF. MATERIAL	REMARK
1	OUTLINE		LTN121XJ-L02					

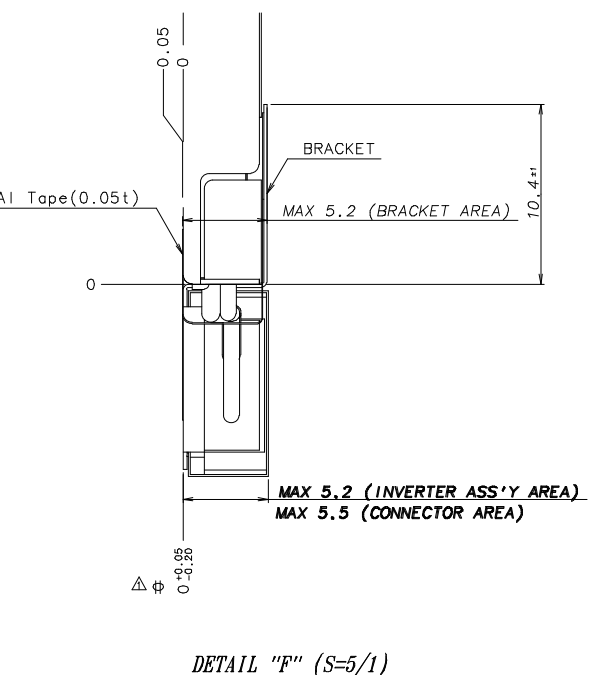
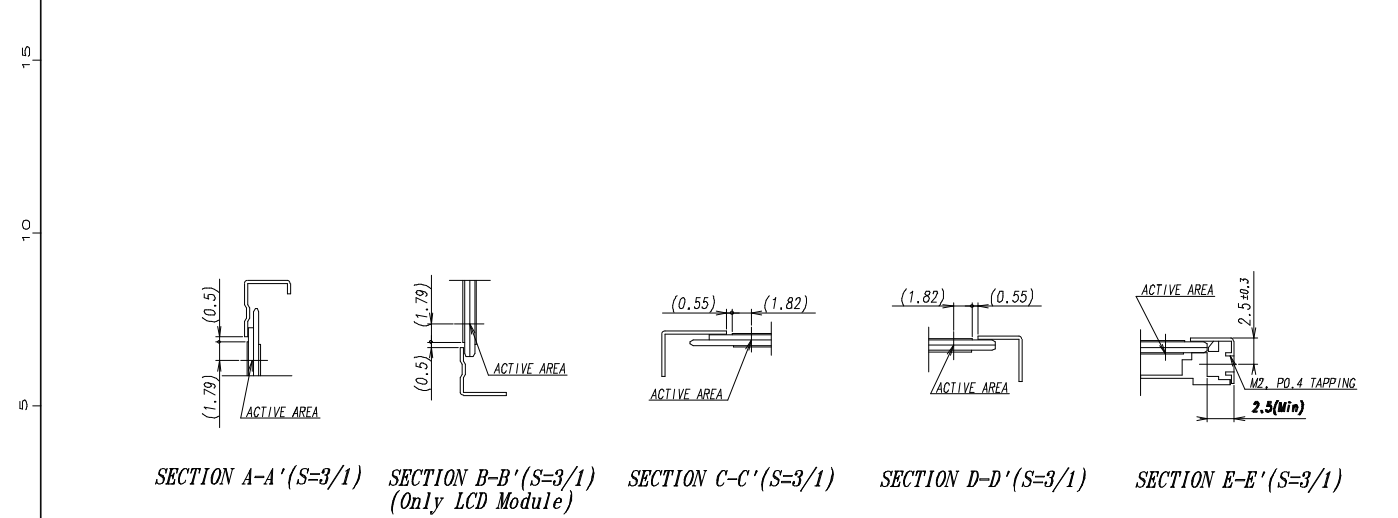
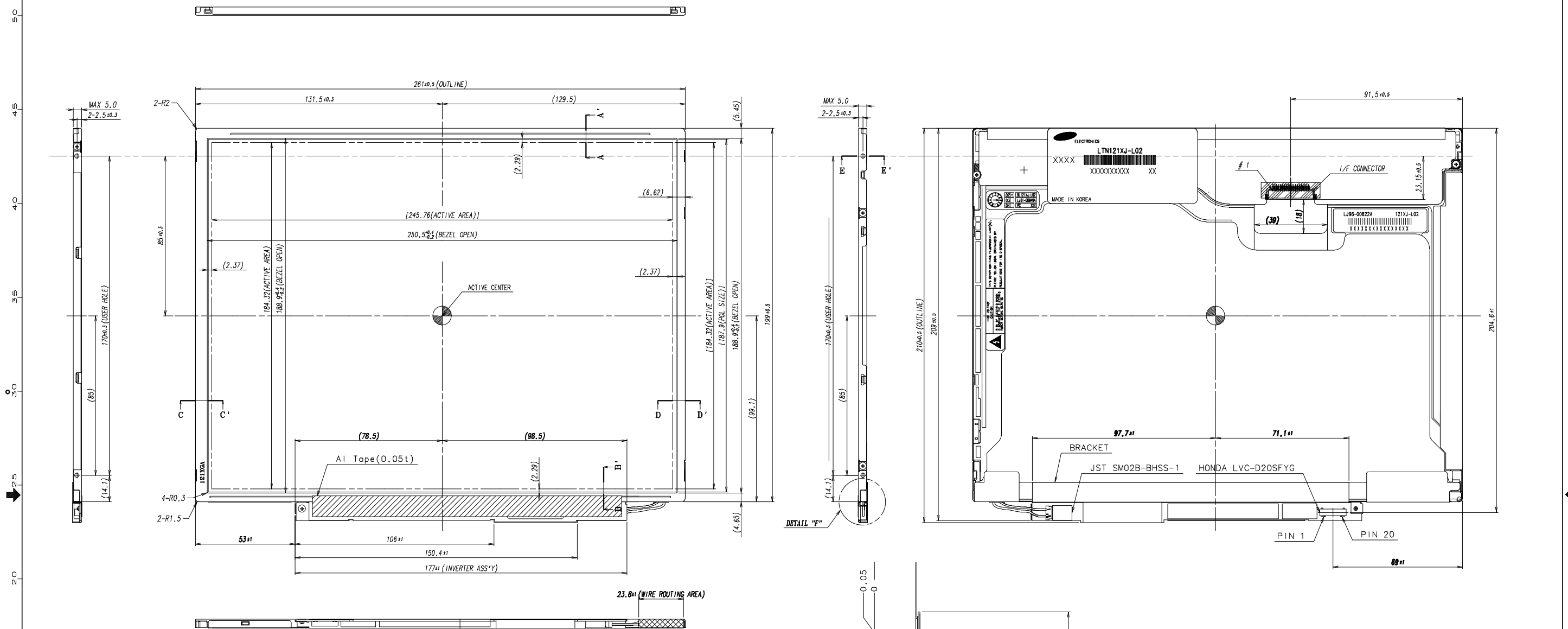

- \* NOTE
- INPUT CONN. SPEC.  
- MAKER : HIROSE  
- PART NO : DF19L-20P-1H
  - MATCHING CONN. SPEC.  
- MAKER : HIROSE  
- PART NO : DF19G-20S-1C
  - CCFT LAMP CONN. SPEC.  
- MAKER : JST  
- PART NO : BHSR-02VS-01  
- LAMP DIAMETER : φ1.8
  - ALLOWED DEPTH OF USERHOLE SCREW INSERTION IS 2.5mm MAX.
  - MEASURING FORCE : 750±250gf-cm

STEP	LEVEL 1	LEVEL 2	LEVEL 3	REV	DATE	DESCRIPTION OF REVISION	CHK'D BY	APP'D BY	MODEL NAME	PART/SHEET NAME	SHEET
0 < X ≤ 4	±0.05	±0.1	±0.2	001	03.07.10	CHANGE TOLERANCE (±0.2 → ±0/-0.2)	J.H.WON	J.H.CHUN	LTN121XJ-L02	OUTLINE DIMENSION	1/1
4 < X ≤ 16	±0.06	±0.15	±0.3								
16 < X ≤ 64	±0.12	±0.25	±0.5								
64 < X ≤ 256	±0.25	±0.4	±0.8								

GENERAL TOLERANCE		CHANGE TOLERANCE (±0.2 → ±0/-0.2)				IMPROVE QUALITY		REASON		J.H.WON	
UNIT	mm	DRA'N BY	DES'D BY	CHK'D BY	APP'D BY	MODEL NAME	PART/SHEET NAME	SHEET	VER.	001	
SCALE	1/1					LTN121XJ-L02	OUTLINE DIMENSION	1/1			
TOLERANCE	LEVEL 3										
SAMSUNG ELECTRONICS											

## 8. GENERAL PRECAUTIONS

### 1. Handling

- (a) When the module is assembled, It should be attached to the system firmly using every mounting holes. Be careful not to twist and bend the modules.
- (b) Refrain from strong mechanical shock and / or any force to the module. In addition to damage, this may cause improper operation or damage to the module and CCFT back-light.
- (c) Note that polarizers are very fragile and could be easily damaged. Do not press or scratch the surface harder than a HB pencil lead.
- (d) Wipe off water droplets or oil immediately. If you leave the droplets for a long time, Staining and discoloration may occur.
- (e) If the surface of the polarizer is dirty, clean it using some absorbent cotton or soft cloth.
- (f) The desirable cleaners are water, IPA(Isopropyl Alcohol) or Hexane. Do not use Ketone type materials(ex. Acetone), Ethyl alcohol, Toluene, Ethyl acid or Methyl chloride. It might permanent damage to the polarizer due to chemical reaction.
- (g) If the liquid crystal material leaks from the panel, it should be kept away from the eyes or mouth. In case of contact with hands, legs or clothes, it must be washed away thoroughly with soap.
- (h) Protect the module from static, it may cause damage to the C-MOS Gate Array IC.
- (i) Use fingerstalls with soft gloves in order to keep display clean during the incoming inspection and assembly process.
- (j) Do not disassemble the module.
- (k) Do not pull or fold the lamp wire.
- (l) Do not adjust the variable resistor which is located on the back side.
- (m) Protection film for polarizer on the module shall be slowly peeled off just before use so that the electrostatic charge can be minimized.
- (n) Pins of I/F connector shall not be touched directly with bare hands.

## 2. STORAGE

- (a) Do not leave the module in high temperature, and high humidity for a long time.  
It is highly recommended to store the module with temperature from 0 to 35 °C and relative humidity of less than 70%.
- (b) Do not store the TFT-LCD module in direct sunlight.
- (c) The module shall be stored in a dark place. It is prohibited to apply sunlight or fluorescent light during the store.

## 3. OPERATION

- (a) Do not connect, disconnect the module in the “Power On” condition.
- (b) Power supply should always be turned on/off by following item 6.3 “ Power on/off sequence “ .
- (c) Module has high frequency circuits. Sufficient suppression to the electromagnetic interference shall be done by system manufacturers. Grounding and shielding methods may be important to minimize the interference.
- (d) The cable between the back-light connector and its inverter power supply shall be a minimized length and be connected directly . The longer cable between the back-light and the inverter may cause lower luminance of lamp(CCFT) and may require higher startup voltage(Vs).

## 4. OTHERS

- (a) Ultra-violet ray filter is necessary for outdoor operation.
- (b) Avoid condensation of water. It may result in improper operation or disconnection of electrode.
- (c) Do not exceed the absolute maximum rating value. ( the supply voltage variation, input voltage variation, variation in part contents and environmental temperature, so on)  
Otherwise the module may be damaged.
- (d) If the module displays the same pattern continuously for a long period of time, it can be the situation when the image “ sticks” to the screen.
- (e) This module has its circuitry PCB' s on the rear side and should be handled carefully in order not to be stressed.