

Data sheet

status Product specification

date of issue July 1990

LTN111

Liquid crystal display

T-41-39

MODULE DESCRIPTION

The LTN111 is a 5 x 7 dot, 16-character, 1-line dot matrix LCD module, with driver and controller LSI IC mounted on a single printed circuit board. The LSI controller incorporates a ROM-based character generator with a 160 characters and RAM display data with 8 characters. The module is capable of generating 160 fixed and 8 write by programme characters. The LTN111 operates from an extensive instruction set: display clear, cursor home, display ON/OFF, cursor ON/OFF, character blink, cursor shift and display shift.

QUICK REFERENCE DATA

Outline dimensions	80 x 36 x 12 mm
Viewing area	64.5 x 13.8 mm
Character format	5 x 7 dots and cursor
Character size	3.07 x 6.56 mm
Dot size (spacing 0.08 mm)	0.55 x 0.75 mm
Mass	≈ 25 g
Drive method	MUX 1:16
Supply voltage	+5 V
Power consumption	7.5 mW
Illumination mode	reflective/trans- flective
Front surface	glossy
Character generator	built in
Data interface	parallel 4 or 8 bits

DISPLAY MODE

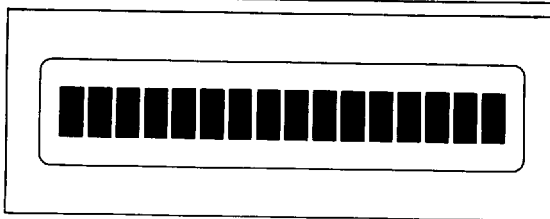

7Z22322

Fig.1 16-character, 1-line LCD module.

TYPE DEPENDENT DATA

TYPE	ILLUMINATION MODE	VIEWING DIRECTION	TO BE USED WITH EL BACKLIGHT
LTN111R-10	reflective	6 o'clock	-
LTN111F-10	transflective	6 o'clock	LXL111-G
LTN111R-50	reflective	12 o'clock	-
LTN111F-50	transflective	12 o'clock	LXL111-G

Liquid crystal display

LTN111

MECHANICAL DATA

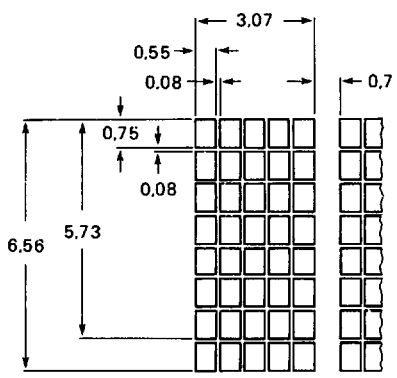
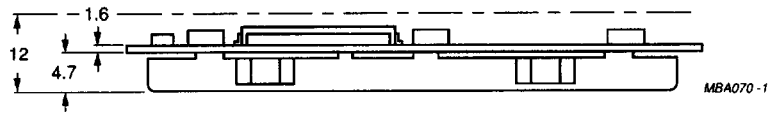
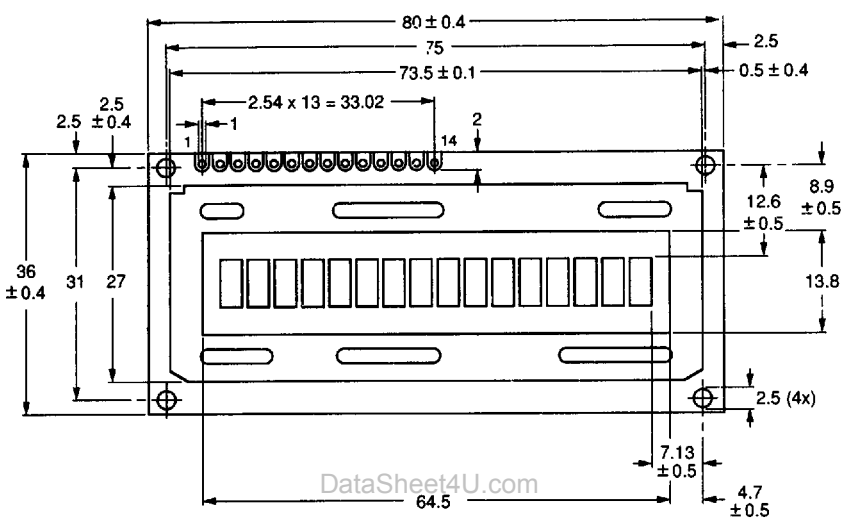

character pattern details 7Z96507

Fig.2 Outline dimensions.

Liquid crystal display

LTN111

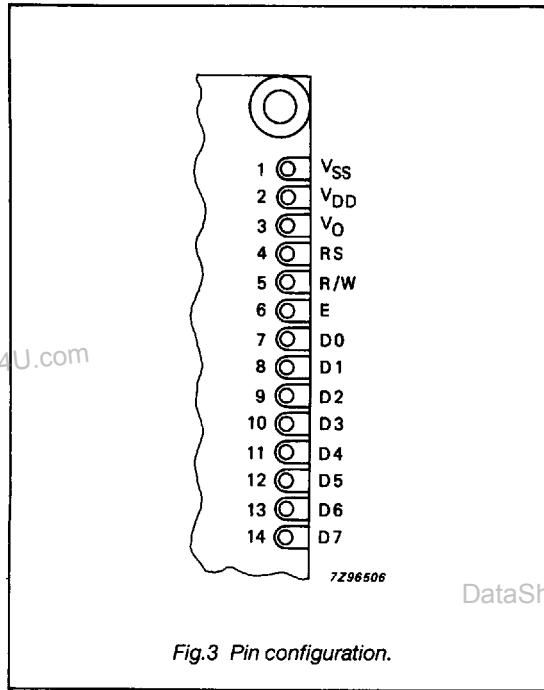

Fig.3 Pin configuration.

PIN DESCRIPTION

PIN NO.	SYMBOL	NAME AND FUNCTION
1	V _{SS}	ground
2	V _{DD}	power supply (logic)
3	V _O	contrast adjustment voltage
4	RS	register select
5	R/W	read/write
6	E	enable
7	D0	I/O data LSB
8	D1	I/O data 2nd bit
9	D2	I/O data 3rd bit
10	D3	I/O data 4th bit
11	D4	I/O data 5th bit
12	D5	I/O data 6th bit
13	D6	I/O data 7th bit
14	D7	I/O data MSB

Notes to pin description

1. Contrast is adjusted by varying the voltage V_O between 0 and 5 V.
2. D7 doubles as busy flag.
3. When the module is interfaced with a microprocessor with 4-bit parallel outputs, pins D0 to D3 are not used.

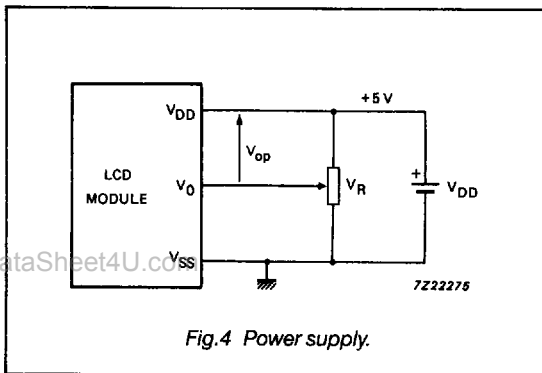

Fig.4 Power supply.

Liquid crystal display

LTN111

RATINGS

Limiting values in accordance with the Absolute Maximum System (IEC 134)

PARAMETER	SYMBOL	MIN.	TYP.	MAX.	UNIT
Supply voltage	V_{DD}	-0.3	-	7.0	V
LCD drive voltage ($V_{DD}-V_O$)	V_{Op}	0	-	9.0	V
Input voltage	V_I	-0.3	-	$V_{DD}+0.3$	V
Storage temperature	T_{stg}	-25	-	+70	°C
Operating ambient temperature	T_{amb}	0	-	+50	°C

OPERATING CHARACTERISTICS

 $T_{amb} = 25\text{ °C}$; $V_{DD} = 5\text{ V}$; all voltages refer to V_{SS} ; unless otherwise specified

PARAMETER	SYMBOL	MIN.	TYP.	MAX.	UNIT
Supply voltage (logic)	$V_{DD}-V_{SS}$	4.75	5.0	5.25	V
Contrast adjustment voltage	V_O	-	0.6	-	V
Temperature compensation of V_O	TC_{V_O}	-	-14	-	mV/°C
LOW level input voltage	V_{IL}	-0.3	-	0.6	V
HIGH level input voltage	V_{IH}	2.2	-	V_{DD}	V
LOW level output voltage $-I_{OL} = 1.2\text{ mA}$	V_{OL}	-	-	0.4	V
HIGH level output voltage $-I_{OH} = 0.205\text{ mA}$	V_{OH}	2.4	-	-	V
Input leakage current	I_I	-	-	1.0	µA
Internal oscillating frequency	f_{OSC}	-	250	-	kHz
Supply current (logic)	I_{DD}	-	1.5	2.0	mA
Power dissipation	P_d	-	7.5	10.0	mW

TIMING CHARACTERISTICS

 $T_{amb} = 0\text{ to }50\text{ °C}$, $V_{DD} = 5\text{ V} \pm 5\%$, unless otherwise specified.

PARAMETER	SYMBOL	MIN.	TYP.	MAX.	UNIT
Enable cycle time	t_{cyc}	1000	-	-	ns
Enable pulse width	t_W	450	-	-	ns
Rise time	t_r	-	-	25	ns
Fall time	t_f	-	-	25	ns
Register select set-up time	t_{rsu}	140	-	-	ns
Read and write set-up time	t_{su}	140	-	-	ns
Data set-up time	t_{dsu}	195	-	-	ns
Data delay time	t_d	-	-	320	ns
Address hold time	t_{AH}	10	-	-	ns
Data hold time write	t_{WH}	10	-	-	ns
Data hold time read	t_{RH}	20	-	-	ns

Liquid crystal display

LTN111

ELECTRO-OPTICAL CHARACTERISTICS

$T_{amb} = 25\text{ }^{\circ}\text{C}$, $V_{DD} = V_{DD\text{ typ}}$, $\alpha = 10^{\circ}$, $\phi = \phi_{opt}$, unless otherwise specified

PARAMETER	SYMBOL	CONDITIONS	TYP.	MAX.	UNIT
Response times	t_{on}	$T_{amb} = 0\text{ }^{\circ}\text{C}$	380	760	ms
		$T_{amb} = 25\text{ }^{\circ}\text{C}$	110	220	ms
		$T_{amb} = 50\text{ }^{\circ}\text{C}$	45	90	ms
	t_{off}	$T_{amb} = 0\text{ }^{\circ}\text{C}$	470	940	ms
		$T_{amb} = 25\text{ }^{\circ}\text{C}$	110	220	ms
		$T_{amb} = 50\text{ }^{\circ}\text{C}$	45	90	ms
Viewing Angles (contrast ratio CR > 3)	α_{opt}	reflective types	30	–	$^{\circ}$
	$\alpha_{2-\alpha_1}$		30	–	$^{\circ}$
	α_{opt}	transflective types reflective operation	30	–	$^{\circ}$
$\alpha_{2-\alpha_1}$	25		–	$^{\circ}$	
	$\alpha_{2-\alpha_1}$	transflective types transmissive operation	30	–	$^{\circ}$
			20	–	$^{\circ}$

For definitions of response times, viewing angles and contrast ratio refer to notes 1 to 3

Liquid crystal display

LTN111

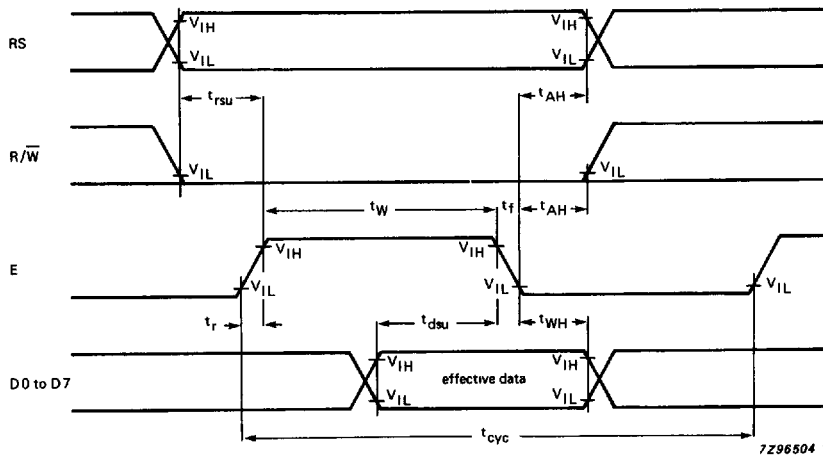

Fig.5 Timing waveforms (write operation).

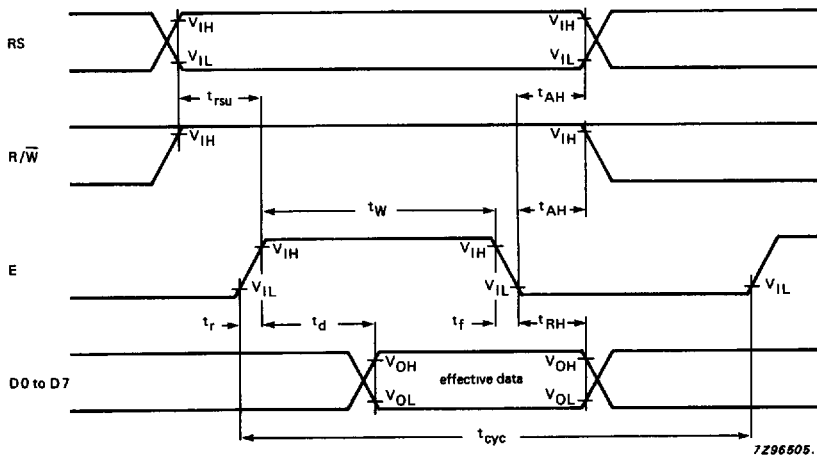

Fig.6 Timing waveforms (read operation).

Liquid crystal display

LTN111

Table 1 Instruction set

INSTRUCTION	ADDRESSES										
	RS	R/W	D7	D6	D5	D4	D3	D2	D1	D0	
Display clear	0	0	0	0	0	0	0	0	0	1	
Cursor home	0	0	0	0	0	0	0	0	1	*	
Entry mode set	0	0	0	0	0	0	0	1	I/D	S	
Display on/off control	0	0	0	0	0	0	1	D	C	B	
Cursor display shift	0	0	0	0	0	1	S/C	R/L	*	*	
Function set	0	0	0	0	1	DL	1	0	*	*	
CG RAM address set	0	0	0	1	A _{CG}						
DD RAM address set	0	0	1	A _{DD}							
Busy flag/address read	0	1	BF	AC							
CG RAM/DD RAM data write	1	write data									
CG RAM/DD RAM data read	1	1	read data								

Notes: I/D = 1:increment
 S = 1:display shift
 D = 1:display on
 C = 1:cursor on
 B = 1:character at cursor position blinks
 S/C = 1:display shift
 R/L = 1:right shift
 DL = 1:8 bits
 BF = 1:during internal operation

I/D = 0:decrement
 S = 0:display freeze
 D = 0:display off
 C = 0:cursor off
 B = 0:character at cursor position does not blink
 S/C = 0:cursor move
 R/L = 0:left shift
 DL = 0:4 bits
 BF = 0:end of internal operation

Table 2 Display position and DD RAM address (HEX)

DataSheet4U.com

www.DataSheet4U.com

Digit

1	2	3	4	5	6	7	8	9	10	11	12	13	14	15	16
00H	01H	02H	03H	04H	05H	06H	07H	08H	09H	0AH	0BH	0CH	0DH	0EH	0FH

DataSheet4U.com

DataSheet4U.com

Liquid crystal display

LTN111

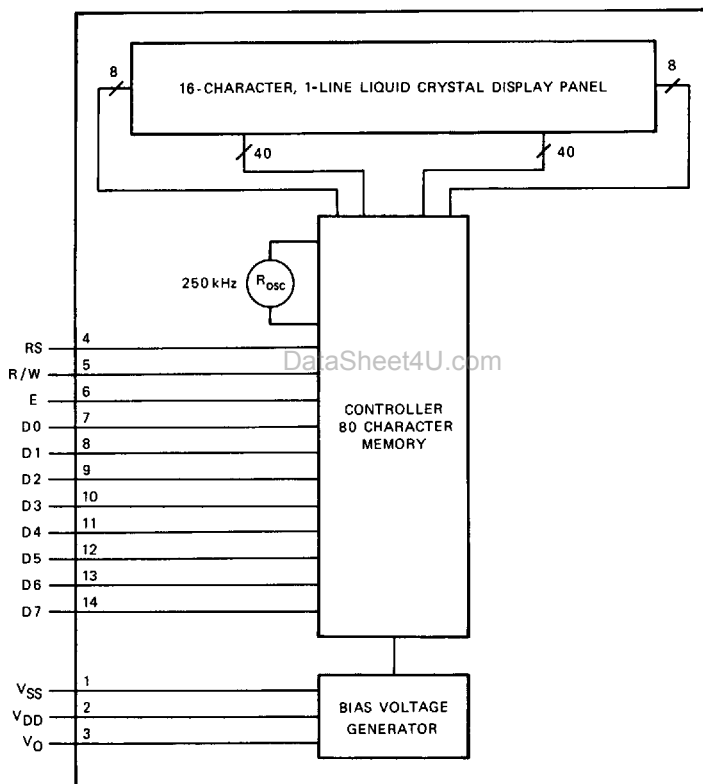

Fig.7 Functional block diagram.

Liquid crystal display

LTN111

Table 3 Input codes vs character pattern

4-bit Lower	Higher	0000	0010	0011	0100	0101	0110	0111	1010	1011	1100	1101	1110	1111
	CG RAM (1)													
xxxx0000	(1)		0	1	2	3	4	5	6	7	8	9	A	B
xxxx0001	(2)		!	@	#	\$	%	&	'	()	*	+	,
xxxx0010	(3)		"	#	2	3	4	5	6	7	8	9	A	B
xxxx0011	(4)		#	3	0	5	c	s	.	7	t	e	e	.
xxxx0100	(5)		#	4	0	T	d	t	.	1	t	t	#	.
xxxx0101	(6)		%	5	E	U	e	u	.	=	7	7	1	s
xxxx0110	(7)		8	6	F	U	f	u	9	h	c	a	3	2
xxxx0111	(8)		'	7	G	W	g	w	7	#	7	7	7	7
xxxx1000	(1)		(8	H	X	h	x	.	4	0	1	7	7
xxxx1001	(2))	9	I	Y	i	y	9	7	7	7	7	7
xxxx1010	(3)		*	:	1	2	3	4	5	6	7	8	9	7
xxxx1011	(4)		+	:	K	K	(7	7	7	7	7	7	7
xxxx1100	(5)		,	<	L	#	1	1	1	7	7	7	7	7
xxxx1101	(6)		-	=	M	I	m	7	7	7	7	7	7	7
xxxx1110	(7)		.	>	N	^	n	7	7	7	7	7	7	7
xxxx1111	(8)		/	?	0	_	0	7	7	7	7	7	7	7

et4U.com

DataShee

DataSheet4U.com

www.DataSheet4U.com

DataSheet4U.com

DataSheet.com

Liquid crystal display

LTN111

Note 1 Definition of contrast ratio (CR).

in positive image mode: $CR = \frac{B_{off}}{B_{on}}$

in negative image mode: $CR = \frac{B_{on}}{B_{off}}$

B_{on} is the brightness of selected segments
 B_{off} is the brightness of non-selected segments

Note 2 Definition of viewing angles α and ϕ .

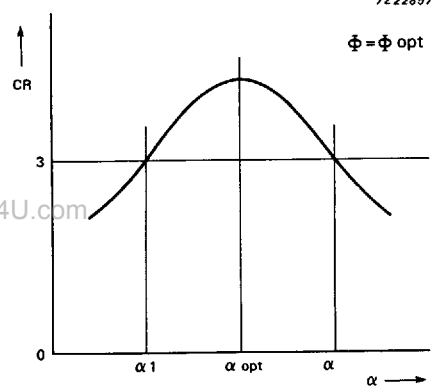
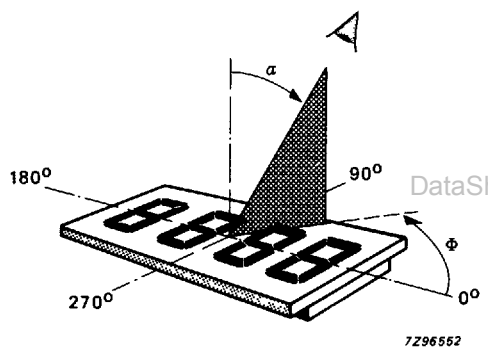

Note 3 Definition of response times.

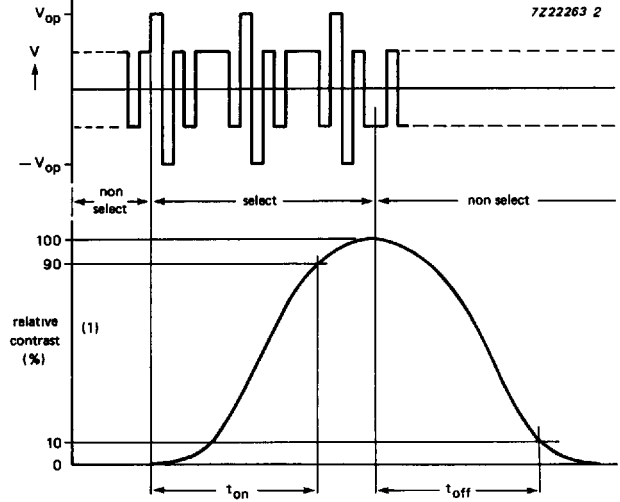

1) measured at $\alpha = 10^\circ$