

**PROTECTION CONCEPTS IN TELECOMMUNICATIONS EQUIPMENT**

A. Bremond

**I INTRODUCTION**

The goal of a telecommunication network (fig.1) is to permit data exchange (speech or digital) between two or more subscribers.

The network is made up of different parts which are subject to various disturbances.

The most susceptible elements are the lines, due to their length and their geographical location.

Disturbances strike the lines and are then propagated to the extremities of the lines at which lie telephone sets and the subscriber line interface cards (SLIC).

So the lines receive two kinds of overvoltages :

Surges of short duration with high peak voltage value (a few hundred micro-seconds for a few thousand volts). These are generated by atmospheric phenomena.

Surges of long duration with medium voltage value (greater than one second for a few hundred volts RMS) which are due to the mains AC power networks.

The purpose of this application note is to analyse these 2 kinds of overvoltages .

**Figure 1 : Classical telecommunication network topology**

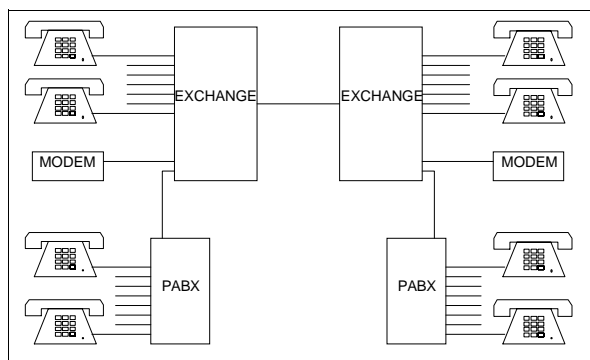

**II OVERVOLTAGES ACROSS TELECOMMUNICATION LINES :**

**II.1 Atmospheric effects :**

Lightning phenomena are the most common surge causes. They are mainly due to a voltage difference between the ground and the clouds (a few 100 kV). Two kinds of strikes may occur:

- 1) Negative discharge with a peak current of 50 kA, rise time of 10µs to 15µs and 100µs duration.
- 2) Positive discharge with a peak value of 150 kA, rise time between 20µs and 50µs and a duration between 100ms and 200ms.

The lightning effect appears on the lines in two ways.

- Direct shock.
- Induced shock.

**Figure 2 : Lightning phenomenon**

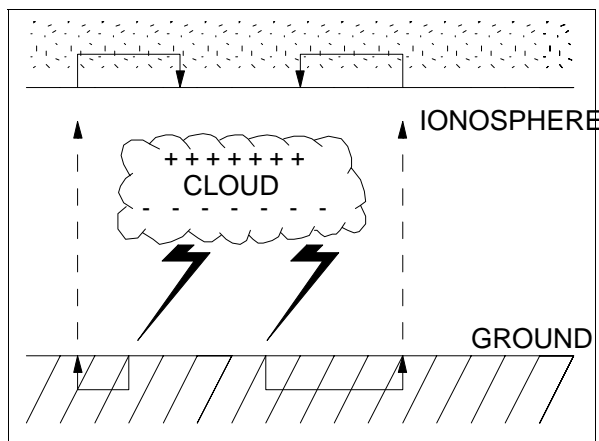

**Figure 3 : Direct lightning strike**

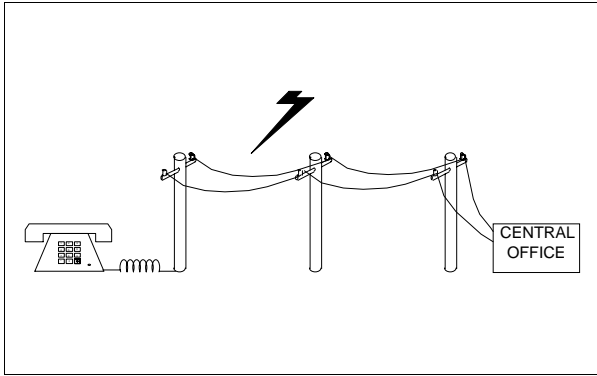
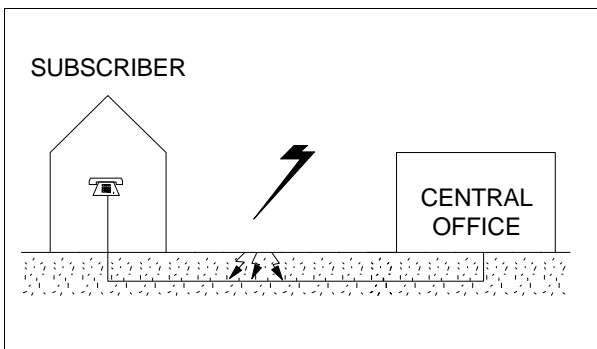

Fig.3 shows the first case which is produced mainly on overhead lines.

Induced shock is more frequent than a direct shock. Lightning strikes the ground and a current flows in the cable shield. This current produces a voltage gradient which in some places is above the insulation capability of the cable material (Fig.4).

**Figure 4 : Induced strike**



**II.2 Proximity and crossing with AC mains lines :**

For these kinds of surges two cases may be seen :

The first one is due to the falling of an AC mains cable on a telephone line.

The second case is produced by the proximity of a subscriber line with an AC mains line or equipment (mainly capacitive coupling).

It is interesting to note for these types of disturbances a RMS value of a few Amps for a duration of between 1 s and 15 mn.

**III PRIMARY AND SECONDARY PROTECTION :**

The figures in chapter II give us an idea of the energy which may appear on the lines. In the field these surge values are lower due to the losses of ground resistance, the capacitive coupling and so on, but are significant nevertheless.

We have to divide these disturbances into two families :

High peak value and short duration (lightning)

Short peak value and long duration (crossing with AC power).

For both cases the present state of the art of silicon protection devices does not permit the suppression of these levels of energy.

A second parameter to keep in mind is the very low clamping factor (1) needed by the IC's used to realize the line interface. This forces the designer to use a protection solution with silicon (fast response time/low clamping factor).

High energy values and low clamping factor impose two protection levels.

**Figure 5 : Primary/secondary protection topology**

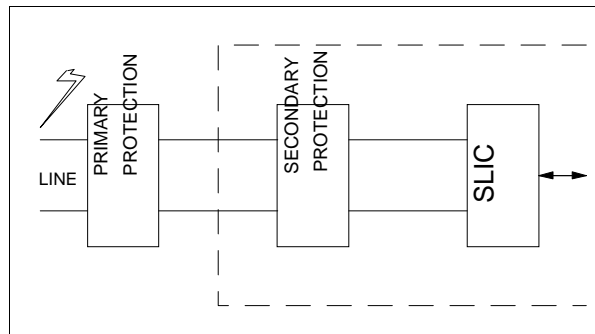

The first level called primary protection (fig.5) located on the connecting terminal of the exchange, suppresses the major part of the disturbance. The second level called secondary protection reduces the remaining overvoltage.

(1) the clamping factor is the ratio of the normal operating voltage over the maximum clamping voltage.

**Figure 6 : Primary/secondary protection level effects**

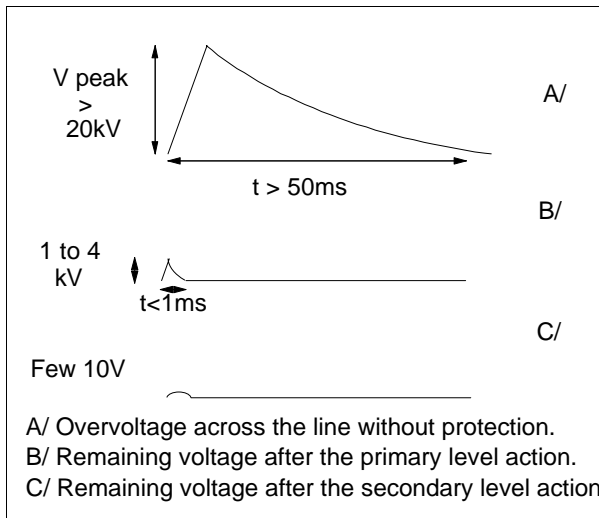

Figure 6 shows the goal of both protection levels.

In this example the surge across the line without protection will be several 10 kV peak value for several 10 ms duration (Fig.6A)

After the primary protection the major part of the energy is cancelled (Fig.6.B). The remaining overvoltage may be a few kV (depending on the  $dv/dt$  of the surge and the surge arrester technology used).

Across the second level protection the voltage does not exceed a few 10 Volts.

III.1 Primary protection :

Actually two kinds of primary protection are used :

- carbon gaps.
- gas tubes.

**Figure 7 : Carbon gap based primary protection**

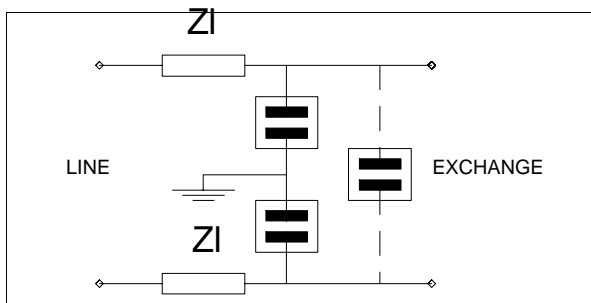

III.1.A Carbon gaps :

These components are made by two carbon electrodes. The carbon gap is a low cost primary protection but it has two major disadvantages :  
 -its short life duration  
 -its variable spark threshold.

III.1.B Gas tubes :

**Figure 8 : Gas tube based primary protection**

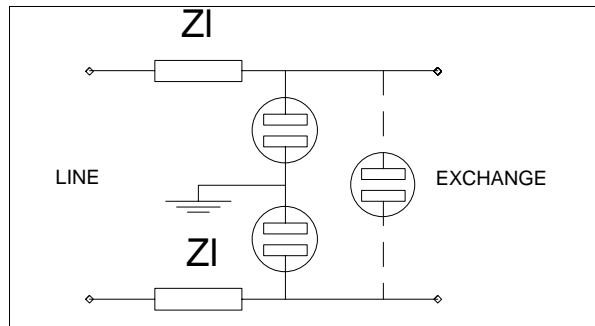

These components are made by two metallic electrodes in a sealed case. Generally the sealed tub contains a low pressure gas.

**Figure 9 : Gas tube characteristics**

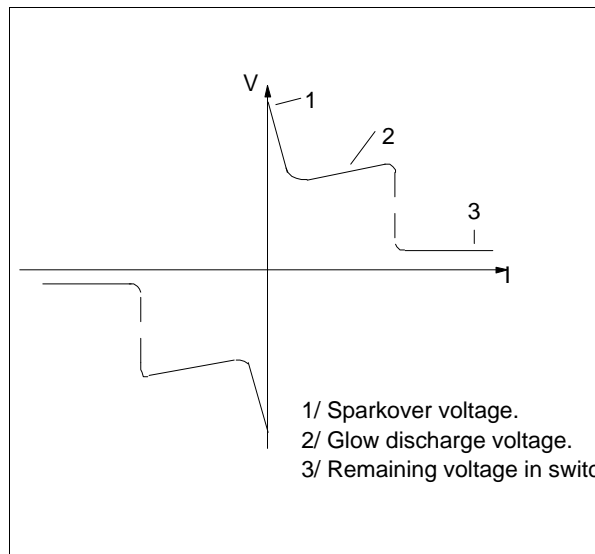

The major disadvantage of this kind of device is its response time, in fact the maximum voltage across the gas tube depends on the  $dv/dt$  of the surge.

## APPLICATION NOTE

III.2 Secondary protection :

III.2.A Series and parallel protection :

**Figure 10 : Series and parallel protection**

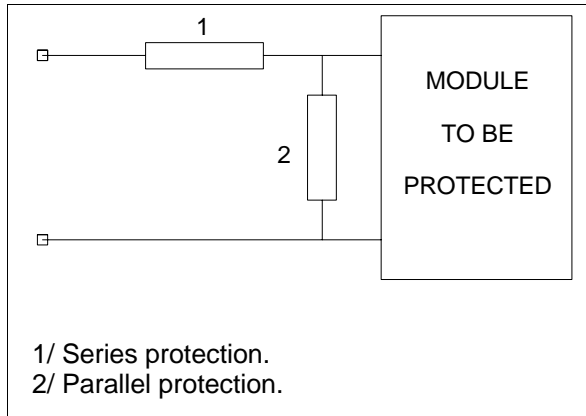

The secondary protection level is generally achieved with two types of devices :

The series protection ensures protection against the proximity of or the crossing with AC power lines.

The parallel protection operates to suppress the overvoltages due to the lightning effects.

\* Series devices :

Series devices operate by opening the circuit or by an increment of the resistance.

**Figure 11 : Fuse protection**

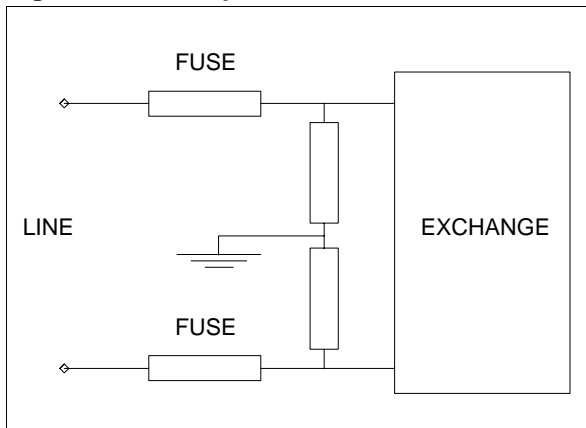

The fuse is a classical case of protection by opening the circuit. Figure 11 shows an

exchange protected by fuses and figure 12 represents an example of the limit curve of the fusing action.

**Figure 12 : Fuse blowing function**

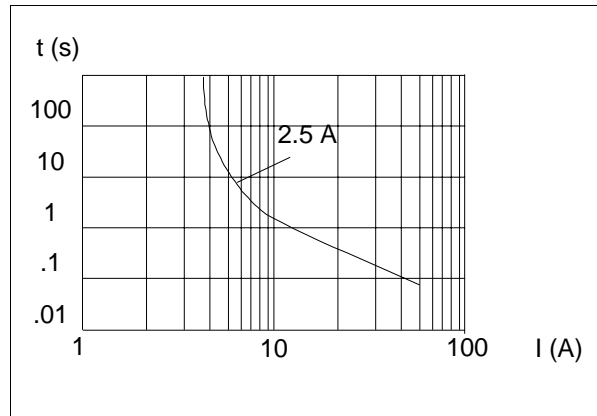

These components provide an absolute security after action, but their major disadvantage is the need for maintenance.

**Figure 13 : PTC based protection**

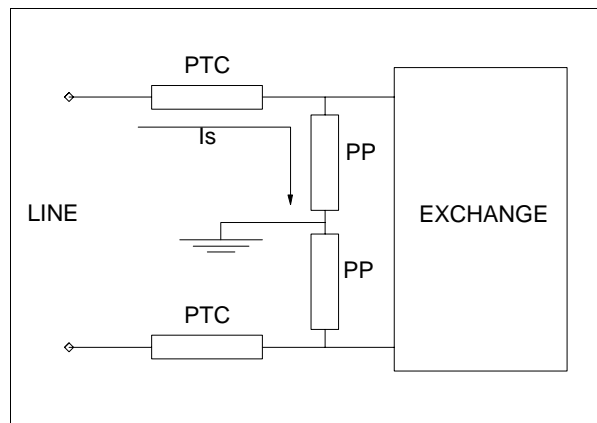

The PTC thermistor is a device which operates by very rapid resistance increase as a function of the temperature.

When the surge occurs across the line, the parallel protection PP is activated.

The surge current  $I_s$ , generated by PP action, flows through the PTC device and increases its internal temperature. As shown in figure 14 the resistance value of the PTC device rises quickly with the temperature.

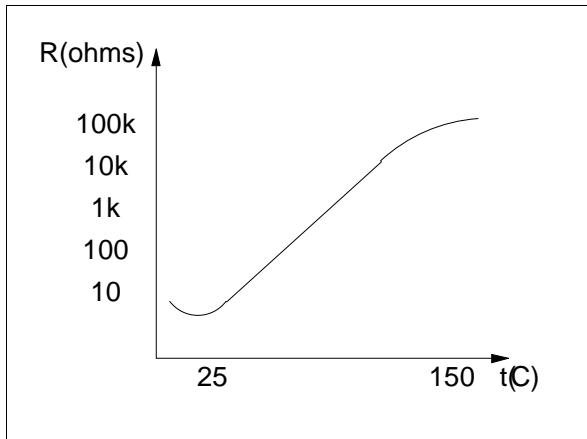
**Figure 14 : Resistance versus temperature**

The major disadvantage of the fuse does not exist with the PTC device. Unfortunately this kind of component has a large tolerance, a long time to return to its stand off point and a drift of its value.

Another series device is the resistance which limits the current through the parallel protector.

\* Parallel devices :

The parallel protection function may be assumed

by different devices based on different technologies.

In fact it is clear that the future in term of SLIC topology is based on the use of ICs. So the consequent requirement for good response times and high clamping factor necessitates the use of silicon protection.

Parallel silicon protection functions in two different modes.

- The clamping mode with the TRANSIL.
- The crowbar mode with the TRISIL.

#### IV CONCLUSION

Due to atmospheric effects and disturbances on mains networks, telecommunication lines have to be protected. Due to the improvement in telecommunication system technology, a need for fast and precise protection solutions results.

The choice of the protection diagram will be done considering local standards and the technology of the devices to be protected.

This protection will be assumed to be dual level

- Primary level to suppress high energy.
- Secondary level to optimize the remaining overvoltage.

Information furnished is believed to be accurate and reliable. However, SGS-THOMSON Microelectronics assumes no responsibility for the consequences of use of such information nor for any infringement of patents or other rights of third parties which may result from its use. No license is granted by implication or otherwise under any patent or patent rights of SGS-THOMSON Microelectronics. Specifications mentioned in this publication are subject to change without notice. This publication supersedes and replaces all information previously supplied.

SGS-THOMSON Microelectronics products are not authorized for use as critical components in life support devices or systems without express written approval of SGS-THOMSON Microelectronics.

© 1995 SGS-THOMSON Microelectronics - Printed in Italy - All rights reserved.

SGS-THOMSON Microelectronics GROUP OF COMPANIES

Australia - Brazil - France - Germany - Hong Kong - Italy - Japan - Korea - Malaysia - Malta - Morocco  
The Netherlands - Singapore - Spain - Sweden - Switzerland - Taiwan - Thailand - United Kingdom - U.S.A.