

# LDM422

## Fully Isolated Limited Distance Modem, RS-232/422 Converter

### Description

The LDM422 is a compact RS-232 to RS-422 converter which features a complete electrical isolation barrier and heavy duty electrical surge protectors. These devices feature a rugged aluminum enclosure small enough to mount on the back panel of typical computer equipment, saving valuable desk and floor space. Isolation is provided by optical couplers and a DC-to-DC converter. The RS-232 connection is through male or female EIA 25-pin connectors. The RS422 connections are made through convenient solderless screw terminals.

The LDM422 series is designed for full duplex operation over two-wire pairs. Outputs are tri-state, allowing multidropping of up to 32 units. Hardware handshake is available over two separate wire pairs. Data rates are 75 to 19,200 baud. Six diagnostic LED indicators are provided (see Figure 1) for installation guidance and system troubleshooting. The RS-232 interface supports Request To Send, Clear To Send, Data Set Ready, Received Line Signal Detect, and Data Terminal Ready. A convenient null modem switch is provided for the data lines. The RS-422 interface supports Request To Send and Clear To Send on separate wire pairs. The LDM422 may be used to convert two sets of send and receive channels by using RTS and CTS circuits as the second data channels. Data rates are the same. The units use 12VAC from a wall-mounted transformer or  $\pm 12$ VDC to pins 9 (+) and 10 (-) of the RS-232 connector.

### Specifications

Model	LDM422				
Baud Rate Range	0 – 19.2K				
Baud Rate	19.2K	9.6K	4.8K	2.4K	1.2K – 0
Distance (miles)	1.14	3	4	5	7
Distance (km)	1.8	5	6.7	8.3	11.7
Maximum Multidrop Units	32. Reduced distances may be required when as many as 32 units are multidropped. No restrictions apply for distances of 1 mile (1.7 km) or less.				
Common Mode Isolation	Surge: 750V Continuous: 500V				
Differential Mode Surge Protection (9 devices)	(AC input) ANSI/IEEE C37.90.1-1989 (all RS-422 inputs and outputs)				
Channel Lines <sup>(1)</sup>	TD, RD, RTS, CTS				
Control Lines <sup>(1)</sup>	RTS, CTS, DTR, DSR, RLSD				
Modes	Asynchronous 4-wire duplex, 2-wire half-duplex, 2-wire simplex				



### Features

- COMPLETE ISOLATION WITH OPTICAL COUPLERS AND POWER DC-TO-DC CONVERTER
- INDUSTRIAL SURGE PROTECTION DEVICES
- SIX LED DIAGNOSTIC INDICATORS
- DC TO 19,200 BAUD AT 6000 FEET (1800M), 9600 BAUD AT 3 MILES (5KM)
- REQUEST-TO-SEND, CLEAR-TO-SEND HANDSHAKE
- TRI-STATE OUTPUTS FOR MULTIDROP APPLICATIONS
- SELECTION OF CONNECTORS
- WIDE OPERATION TEMPERATURE RANGE
- SOLDERLESS SCREW TERMINAL FIELD CONNECTIONS

Dataforth does not authorize or warrant its products for use in life support/critical applications.

Model	LDM422
Null Modem Switch	1 (Reverses RS-232 pins 2 and 3)
RS-422 Output Drive	20mA min/output
RS-422 Input Impedance	6k $\Omega$ min/input
Power:	
AC operation <sup>(2)</sup>	12VAC, $\pm 10\%$ , 10W screw terms 1 & 2
DC operation	+11.5VDC to +17.0VDC @ 400mA on pin 9 -11.5VDC to -17.0VDC @ 400mA on pin 10
Operating Environment	0°C to +70°C 0 to 95% relative humidity, noncondensing
Dimensions	6.6 in x 2.1 in x 1.28 in (167.6 mm x 53.3 mm x 32.5 mm)
Weight	7 oz (200 g) max
PT3 and PT3E	11.0 oz (311.8 g) max
MTBF <sup>(3)</sup>	> 100,000 hrs

Notes: (1) TD = Transmit Data, RD = Receive Data, RTS = Request To Send, CTS = Clear To Send. DTR = Data Terminal Ready, DSR = Data Set Ready, RLSD = Received Line Signal Detect. (2) 120VAC and 220VAC power transformers are available. (3) Ground-benign environmental conditions (no salt atmosphere, <50°C ambient temperature).

Call 800-444-7644 or Fax (520) 741-0762 for Information and Assistance  
... or visit our web site at [www.dataforth.com](http://www.dataforth.com)

**DATAFORTH**<sup>®</sup>  
A Burr-Brown Company

**Figure 1. LDM422 Logic Diagram**

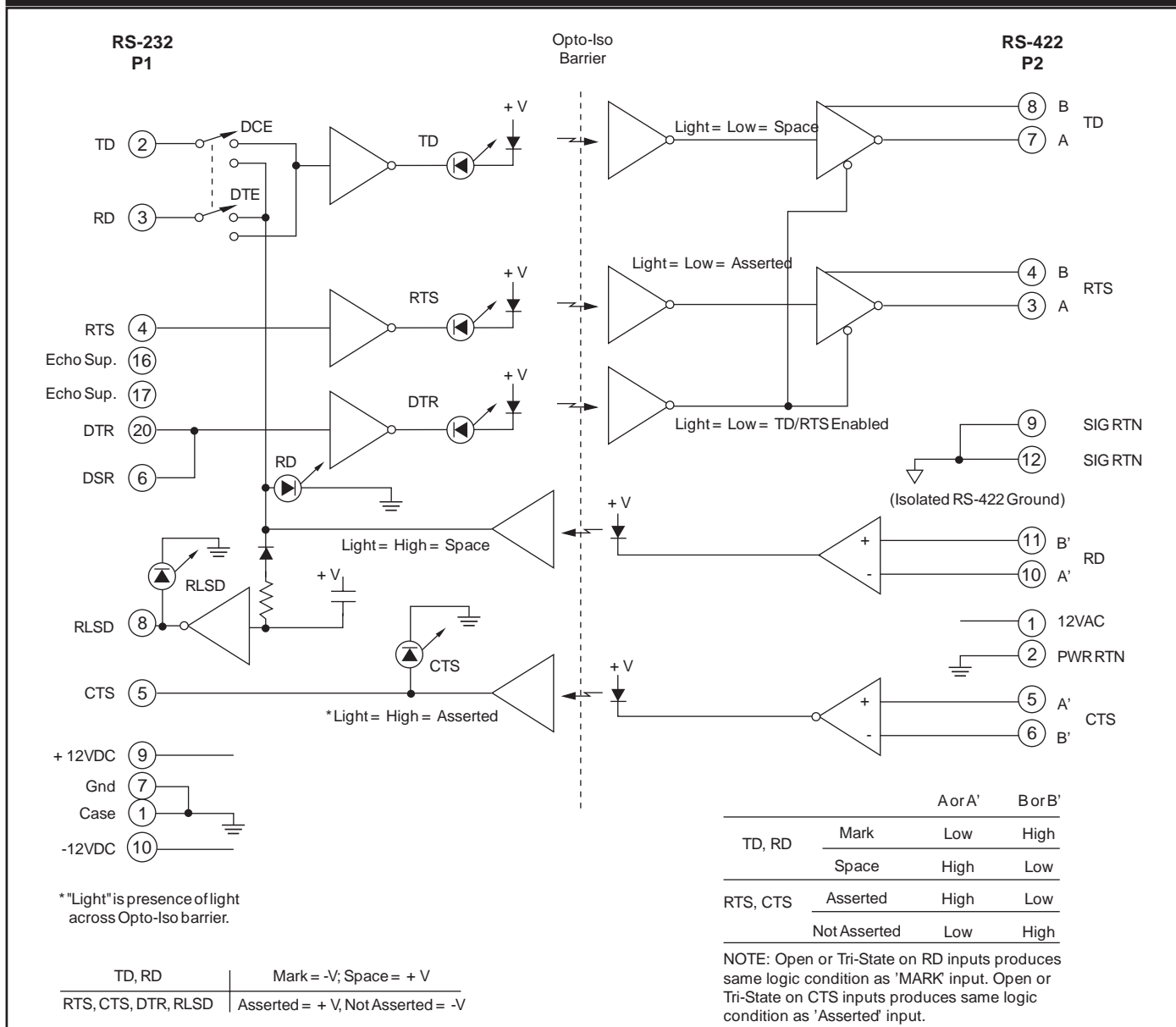

RS-232 P1 Pin Descriptions			RS-422 P2 Pin Descriptions		
Pin 1	Case	Case Ground	Pin 1	12VAC	
Pin 2	TD	Transmit Data	Pin 2	PWR RTN	
Pin 3	RD	Receive Data	Pin 3	RTS A	
Pin 4	RTS	Request To Send	Pin 4	RTS B	
Pin 5	CTS	Clear To Send	Pin 5	CTS A'	
Pin 6	DSR	Data Set Ready (connected to Data Terminal Ready)	Pin 6	CTS B'	
Pin 7	GND		Pin 7	TD A	
Pin 8	RLSD	Receive Line Signal Detect	Pin 8	TD B	
Pin 9	+12VDC	Positive DC Supply Input	Pin 9	SIG RTN	
Pin 10	-12VDC	Negative DC Supply Input	Pin 10	RD A'	
Pin 16	Echo Sup	Echo Suppression (tie to pin 17 to enable)	Pin 11	RD B'	
Pin 17	Echo Sup	Echo Suppression (tie to pin 16 to enable)	Pin 12	SIG RTN	
Pin 20	DTR	Data Terminal Ready (connected to Data Set Ready)			

The LDM422 conforms to EIA RS-232 and RS-422 specifications. Data Terminal Ready must be asserted by the host RS-232 port before the LDM422 can transmit data. When Data Terminal Ready is not asserted all outputs of the LDM422 are high impedance, allowing up to 32 LDM422 units to be multidropped on a common communications cable. See Figures 1 and 3 for details.

Request To Send and Clear To Send are carried through the RS-422 port as two separate wire pairs. These may be used for full duplex flow control.

### Cable Capacitance Effects On Distances

Specified distances in the specifications are for the wire sizes 18-24AWG (0.82-0.20mm<sup>2</sup>) with a maximum capacitance of 25pF/ft (82pF/m). For higher capacitance cables, decrease distance

specifications for 2400 baud and above by a proportionate amount. For example, shielded cable with 50pF/ft (164pF/m) would reduce the distances by 50%. Recommended wire gauges are #18 to #24 (0.82-0.20mm<sup>2</sup>).

For baud rates of 1200 and below, distances are limited by DC voltage drop. For 2400 baud and above, distances are limited by pulse distortion. The use of low-capacitance cable can extend the distances shown. Belden 9182 and 9184 are, respectively, single and dual twisted-pair cables that are especially designed for high-speed data communications applications. With these cables the distances can be extended by 50%. However, the DC-resistance-limited distance given under 1200 baud may not be exceeded.

Cable capacitance for individually shielded wire pairs is usually given by manufacturers as capacitance between wires and capacitance from each wire to the shield. The effective transmission line capacitance is approximately the interwire capacitance plus one-half of the wire-to-shield capacitance.

## Installation

Installation of the LDM422 consists of attaching it to its mating 25-pin connector on the terminal of the host computer, either directly or through a cable. Optional mounting screws and screw jacks are provided.

The DCE/DTE (Data-Communication Equipment/Data Terminal Equipment) switch must be set to be complementary to the terminal or computer port (DCE connects to DTE and DTE to DCE). Since the LDM422 is a communications device, its normal setting is DCE.

In the event that the host port is not known, the LED indicators may be used to find the proper switch setting. The transmit and receive LEDs will be off during a "MARK" which is the normal, or standby, condition when no data is being transmitted. Set the switch to the position which allows these LEDs to be off. The field wiring as shown in Figure 2 must be correct. It is sometimes useful to tie the RS-422 data output back to the RS-422 input during initial check-out.

The four other LEDs indicate the status of various control conditions and will be on when these functions are asserted. An open circuit to Request To Send will be interpreted as assertion, allowing convenient operation with equipment not supporting this function. An open circuit on the Receive Data line of the RS-422 circuits will be interpreted as a "MARK".

For 2-wire half-duplex and for 2-wire multi-drop installations, echo suppression is available by strapping P1 pin 16 to P1 pin 17. Then RTS asserted enables echo suppression and forces RD (P1 pin 3) to a "MARK", -V.

Data Terminal Ready, DTR, must be asserted before the LDM422 can transmit data. This is normally done by the host computer. For situations where the host equipment does not have the capability of supplying a DTR signal, RLSD may be used to automatically assert DTR. On the RS-232 connector P1 of each LDM422, simply connect RLSD pin 8 to DTR pin 20. This connection is not appropriate for multi-drop installations.

**Figure 2. Field Wiring, LDM to LDM**

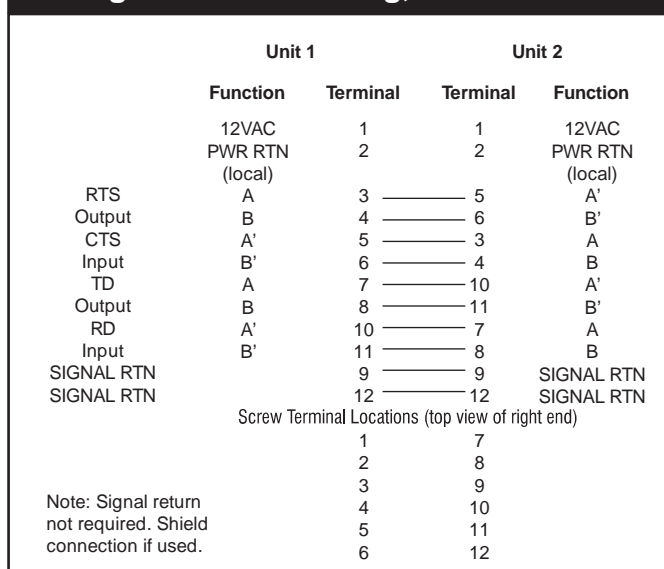

Notes: (1) For data channels MARK is A negative relative to B. (2) For control lines Assertion is A positive relative to B. (3) RTS = Request To Send, CTS = Clear To Send, TD = Transmitted Data, RD = Received Data. (4) Recommended wire sizes are 14AWG to 22AWG. Belden 8442 or Signal 1172 are typical low cost, nonshielded, twisted pair cables for use with LDM422. (5) Signal return is not required. Cable shield, if used, should be connected to SIGNAL RTN. (6) For the data rates of the LDM422, termination resistors are not normally needed. If desired they may be easily attached to the screw terminals. Use a 220Ω resistor across receiver A' and B' terminals at the extreme ends of the cable.

For multi-drop installations the following points should be considered (see Figure 3 for multidrop wiring connections):

1. If the LDM422 is not powered, it releases the transmit bus so other RS-422 devices may use the bus.
2. Local equipment connected to the RS-232 connector must not leave DTR in the asserted state.
3. An open circuit or zero volts on the RS-232 connector pin 20 (DTR) is equivalent to disassertion.
4. DTR should be asserted at least 5.0μs before start bit and disasserted at end of last stop bit. This disables RS-422 line after 6.0μs min.

**WARNING!** Because PWR RTN and RS-232 GND (P1-7) and shield (P1-1) are common, when powering more than one unit from the same transformer, wire all units' 12VAC's together to one side of the secondary and all PWR RTN's together to the other side of the secondary.

**Figure 3. LDM422 Multidrop Wiring Connection**

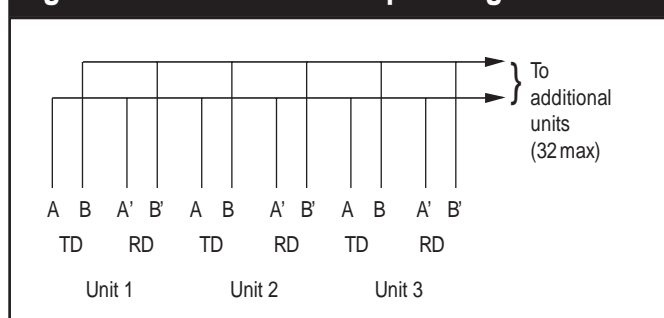

**Figure 4. LDM422 Mechanical Drawing**

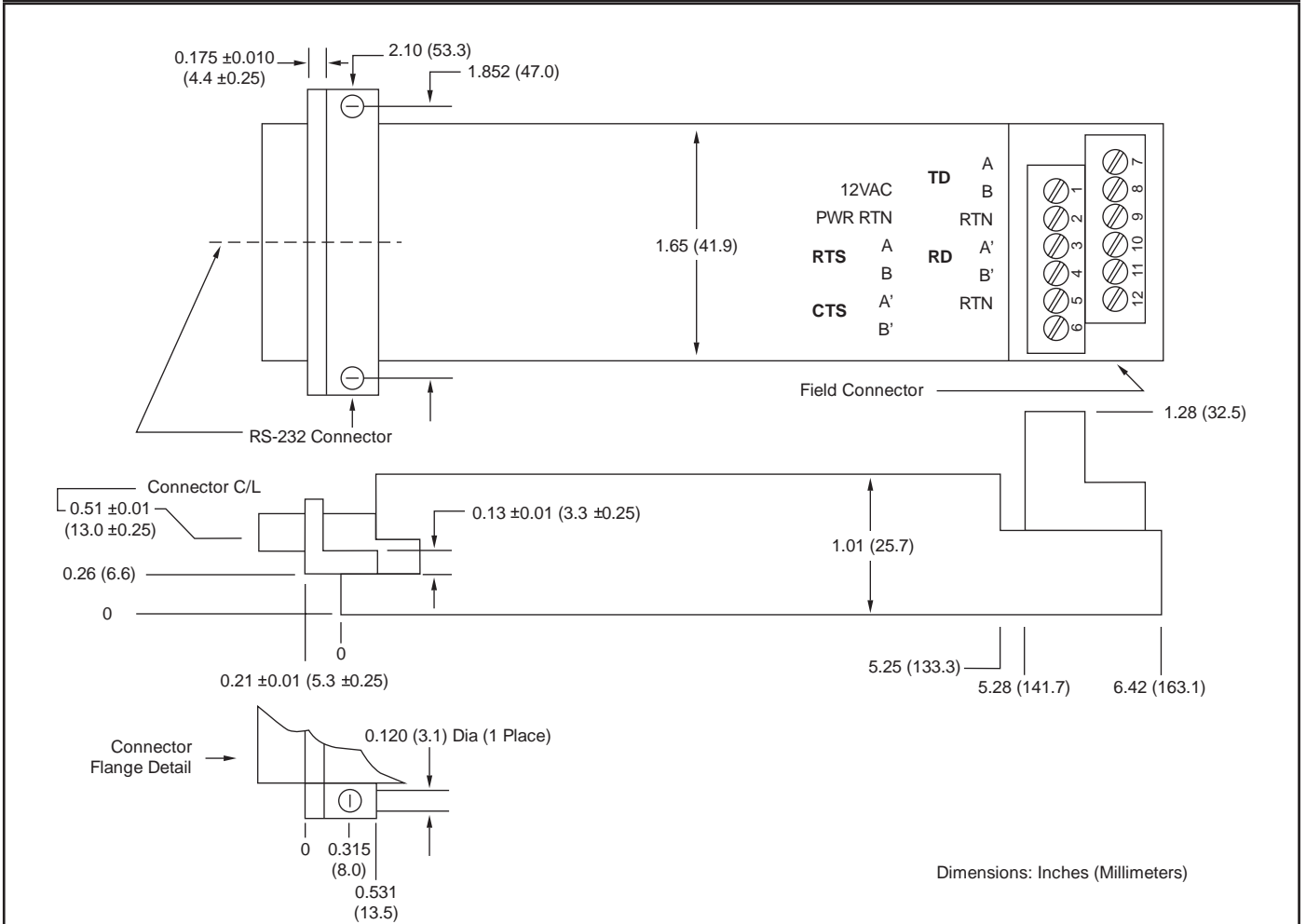

**Ordering Information**

LDM422-P	Male RS-232 connector
LDM422-S	Female RS-232 connector
LDM422-PT	Male RS-232 connector and U.S. power transformer
LDM422-ST	Female RS-232 connector and U.S. power transformer
LDM422-PE	Male RS-232 connector, Euro power transformer
LDM422-SE	Female RS-232 connector, Euro power transformer
PT3	Wall mount U.S. power transformer, 120VAC
PT3E	Wall mount Euro power transformer, 220VAC