

STA438A

Silicon NPN Triple Diffused Planar Darlington

Maximum Ratings

(Ta = 25°C)

Item	Symbol	Rated	Unit
Collector-to-Base Voltage	V _{CB0}	200	V
Collector-to-Emitter Voltage	V _{CEO}	200	V
Emitter-to-Base Voltage	V _{EB0}	6	V
Collector Current	I _c	3	A
Collector Current	I _{cP}	6 (P _w ≤ 10ms, Du ≤ 50%)	A
Total Power Dissipation	P _T	4 (Ta = 25°C)	W
		20 (Tc = 25°C)	
Operating Junction Temperature	T _j	150	°C
Storage Temperature	T _{stg}	-40 ~ +150	°C

Electrical Characteristics

(Ta = 25°C)

Item	Symbol	Conditions	Specification			Unit
			min	typ	max	
Collector Cut-off Current	I _{CB0}	V _{CB} = 200V			100	μA
Emitter Cut-off Current	I _{EB0}	V _{EB} = 6V			10	mA
Collector-to-Emitter Voltage	V _{CEO}	I _c = 10mA	200			V
DC Forward Current Transfer Ratio	h _{FE}	V _{CE} = 4V, I _c = 1A	1000			
Collector-to-Emitter Saturation Voltage	V _{CE(sat)}	I _c = 1A, I _B = 1.5mA			2.0	V

Equivalent Circuit Diagram

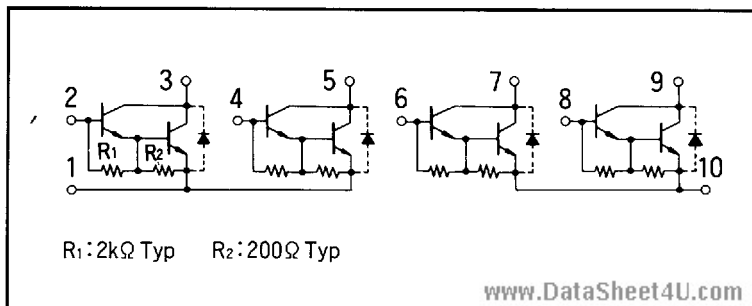

Characteristic Curves

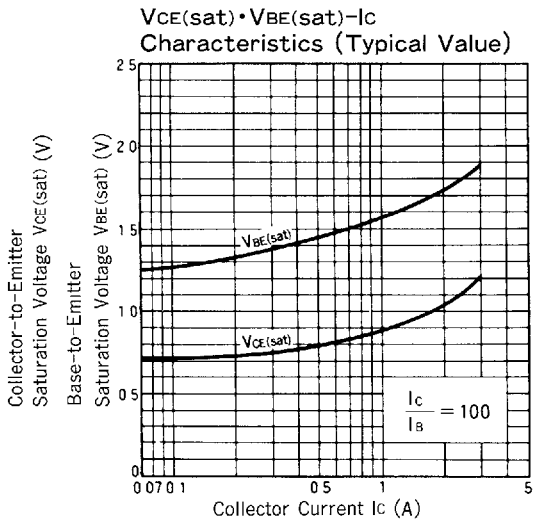
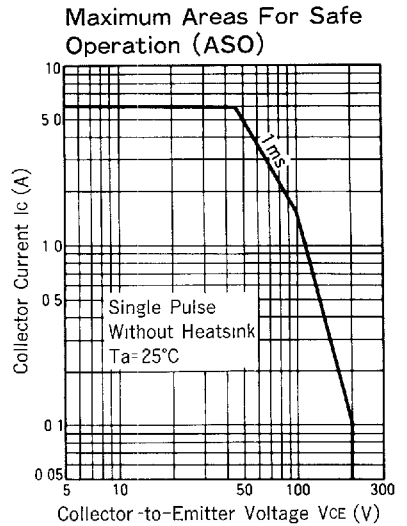
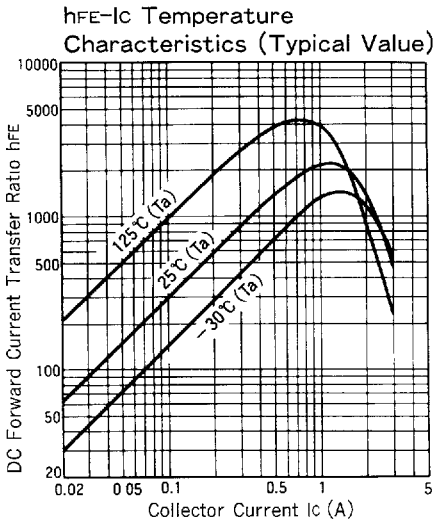
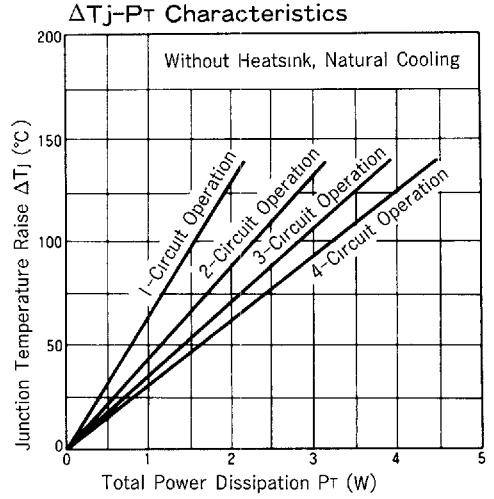
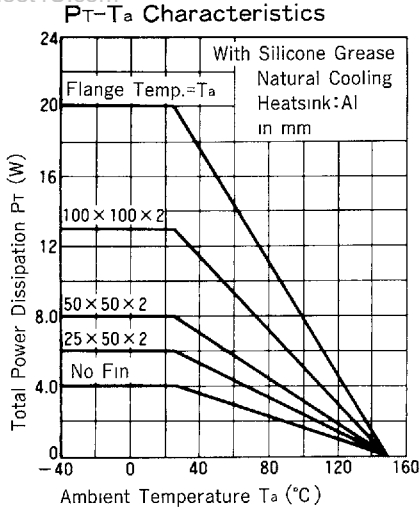

Notes on using products

www.DataSheet4U.com

Outline Drawings (Unit:in mm)

STA Family

STA300 Series

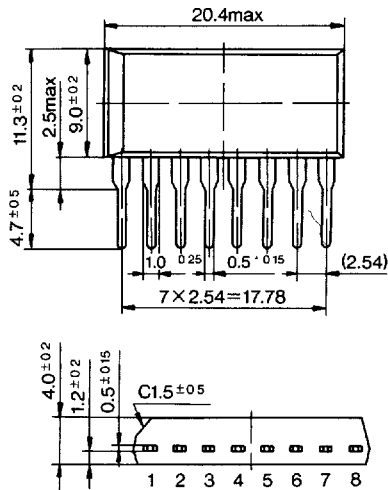

Weight Approx. 2.0g

STA400 Series

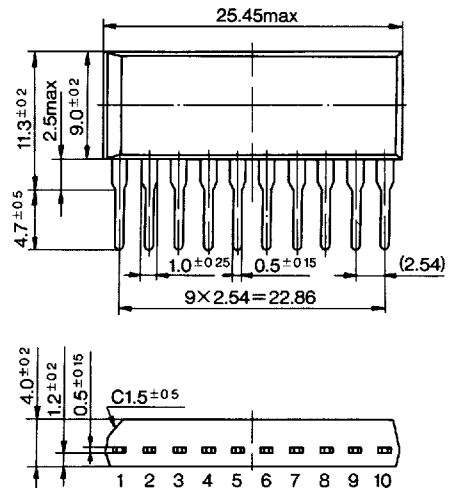

Weight Approx. 2.6g

SMA Family

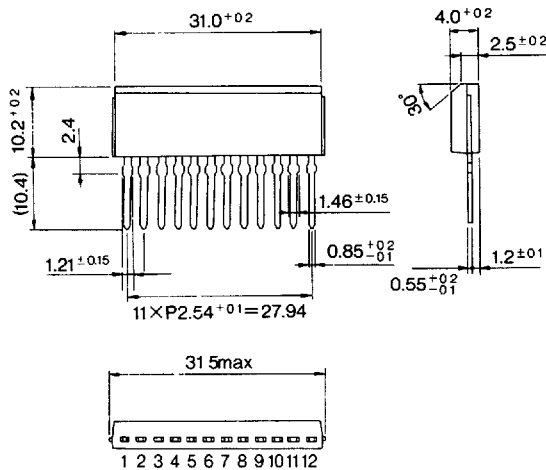

Weight Approx. 4.0g

SLA Family

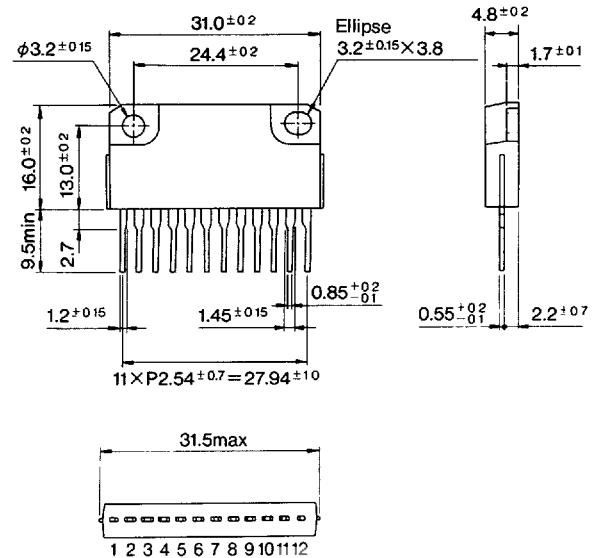

www.DataSheet4U.com

Weight Approx. 6.0g