

KS0715

33 COM / 100 SEG DRIVER & CONTROLLER FOR STN LCD

January.2000

Ver. 4.0

Prepared by: Ko Jae Su | Jae-Su, Ko

Ko1942@samsung.co.kr

Contents in this document are subject to change without notice. No part of this document may be reproduced or transmitted in any form or by any means, electronic or mechanical, for any purpose, without the express written permission of LCD Driver IC Team.

KS0715 Specification Revision History		
Version	Content	Date
1.0	CAP3P → C3+, CAP2P → C2+, CAP1P → C1+ CAP3M → C3-, CAP2M → C2-, CAP1M → C1- Oscillator frequency FOSC (kHz) = → 19 (Min.): 22.5 (Typ.): 26 (Max.) FCL (kHz) = → 2.37 (Min.): 2.81 (Typ.): 3.25 (Max.)	
2.0	Temperature coefficient TEMPS = L: -0.0%/°C → -0.05%/°C Absolute maximum ratings VLCD: +0.3 to +15.0 → -0.3 to +17.0 Dynamic current consumption IDD1: 40μA (Max.) IDD2: 75μA (Typ.), 100μA (Max.)	
3.0	Oscillator frequency (internal) 19: 22.5: 26 → 17: 22.5: 27 Oscillator frequency (external) 2.13: 2.81: 3.25 → 2.13: 2.81: 3.37	
3.1		Apr.1999
4.0	Change VDD Range : 2.4V to 5.5V → 2.4V to 3.6V	Jan.2000

CONTENTS

INTRODUCTION	1
FEATURES	1
BLOCK DIAGRAM	3
PAD CONFIGURATION	4
PAD CENTER COORDINATES	5
PIN DESCRIPTION	7
POWER SUPPLY	7
LCD DRIVER SUPPLY	7
SYSTEM CONTROL	8
MICROPROCESSOR INTERFACE	9
LCD DRIVER OUTPUTS	11
TEST PINS.....	11
FUNCTIONAL DESCRIPTION	12
MICROPROCESSOR INTERFACE	12
DISPLAY DATA RAM (DDRAM)	16
LCD DISPLAY CIRCUITS.....	19
LCD DRIVER CIRCUIT	21
POWER SUPPLY CIRCUITS	22
REFERECE CIRCUIT EXAMPLES.....	28
RESET CIRCUIT	29
INSTRUCTION DESCRIPTION	30
SPECIFICATIONS	43
ABSOLUTE MAXIMUM RATINGS	43
DC CHARACTERISTICS	44
REFERENCE DATA	47
AC CHARACTERISTICS	49
REFERENCE APPLICATIONS	53
MICROPROCESSOR INTERFACE	53
CONNECTIONS BETWEEN KS0715 AND LCD PANEL	54
TCP PIN LAYOUT (SAMPLE).....	57

INTRODUCTION

The KS0715 is a driver & controller LSI for graphic dot-matrix liquid crystal display systems. It contains 33 common and 100 segment driver circuits. This chip is connected directly to a microprocessor, accepts serial or 8-bit parallel display data and stores in an on-chip display data RAM of 65 x 132 bits. It provides a highly-flexible display section due to 1-to-1 correspondence between on-chip display data RAM bits and LCD panel pixels. And it performs display data RAM read/write operation with no external operating clock to minimize power consumption. In addition, because it contains power supply circuits necessary to drive liquid crystal, it is possible to make a display system with the fewest components.

FEATURES

Driver Output Circuits

- 33 common outputs / 100 segment outputs

On-chip Display Data RAM

- Capacity: 65 x 132 = 8,580 bits
- Bit data "1": a dot of display is illuminated.
- Bit data "0": a dot of display is not illuminated.

Multi-chip Operation (Master, Slave) Available

Applicable Duty Ratios

Duty ratio	Applicable LCD bias	Maximum display area
1/33	1/5 or 1/6	33 × 100

Microprocessor Interface

- 8-bit parallel bi-directional interface with 6800-series or 8080-series
- Serial interface (only write operation) available

Various Instruction Setting

On-chip Low Power Analog Circuit

- On-chip oscillator circuit
- Voltage converter (x2, x3 and x4)
- Voltage regulator (temperature coefficient: -0.05%/°C, -0.2%/°C)
- On-chip electronic contrast control function (32 steps)
- Voltage follower (LCD bias: 1/5 or 1/6)

Operating Voltage Range

- Supply voltage (V_{DD}): 2.4 to 3.6 V
- LCD driving voltage (V_{LCD} = V_O - V_{SS}): 4.0 to 15.0 V

Low Power Consumption

- 100 μA Typ. (V_{DD} = 3V, x4 boosting, V_O = 8V, internal power supply ON and display OFF)
- 10 μA Max. (during power save [standby] mode)

Wide Operating Temperature Range

- T_a = -40°C to +85°C

Package Type

- Gold bumped chip or TCP

Series Specifications

Product code	TEMPS pin	Temp. coefficient	Package	Chip thickness
KS0715UM-L0CC	0 (VSS connected)	-0.05%/°C	COG	670 μm
KS0715UM-L4CC				470 μm
KS0715UM-H0CC	1 (VDD connected)	-0.2%/°C		670 μm
KS0715UM-H4CC				470 μm
KS0715TB-XX-L0TF	0 (VSS connected)	-0.05%/°C	TCP	670 μm
KS0715TB-XX-L4TF				470 μm
KS0715TB-XX-H0TF	1 (VDD connected)	-0.2%/°C		670 μm
KS0715TB-XX-H4TF				470 μm

* XX: TCP ordering number

BLOCK DIAGRAM

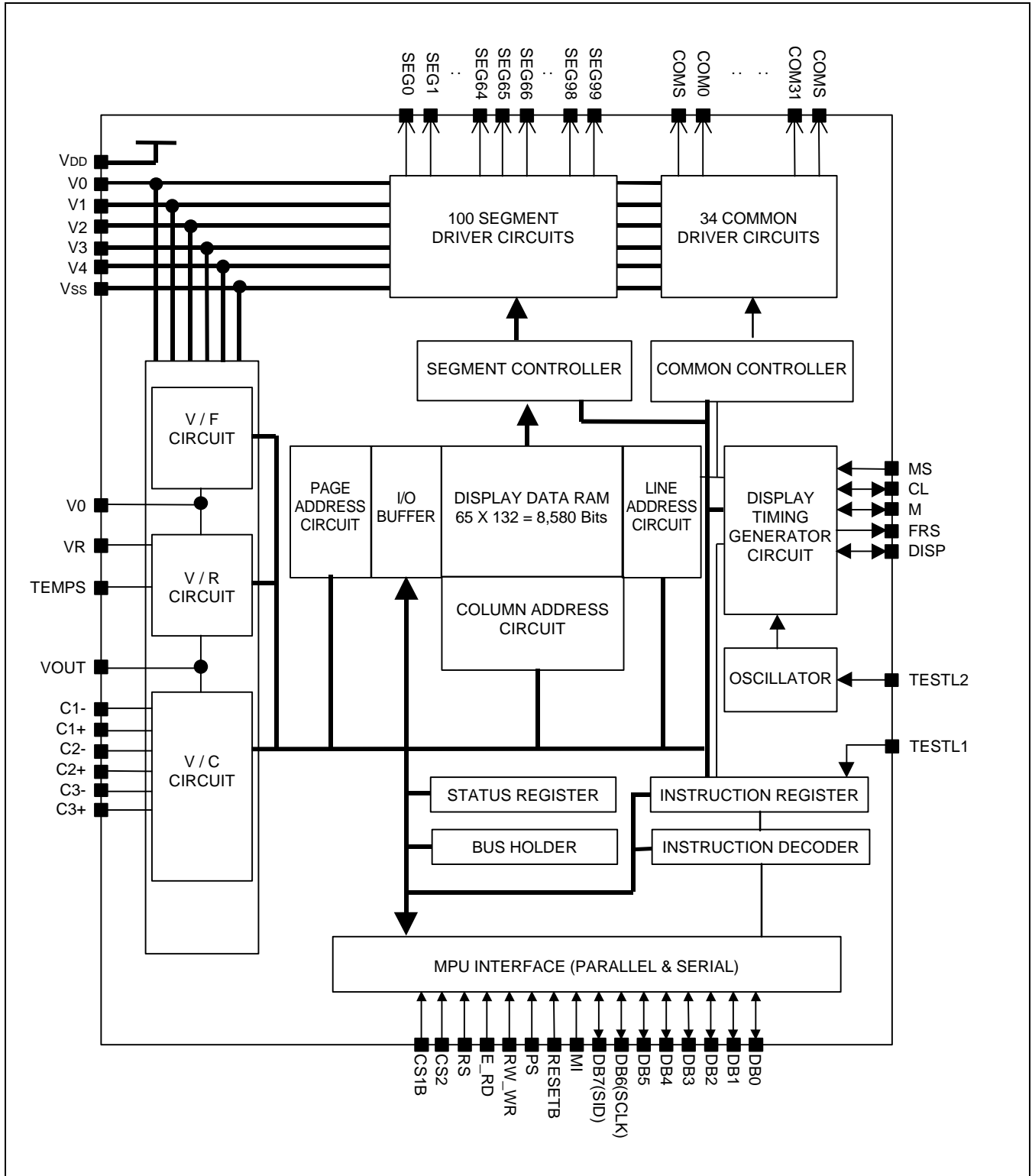

Figure 1. Block Diagram

PAD CONFIGURATION

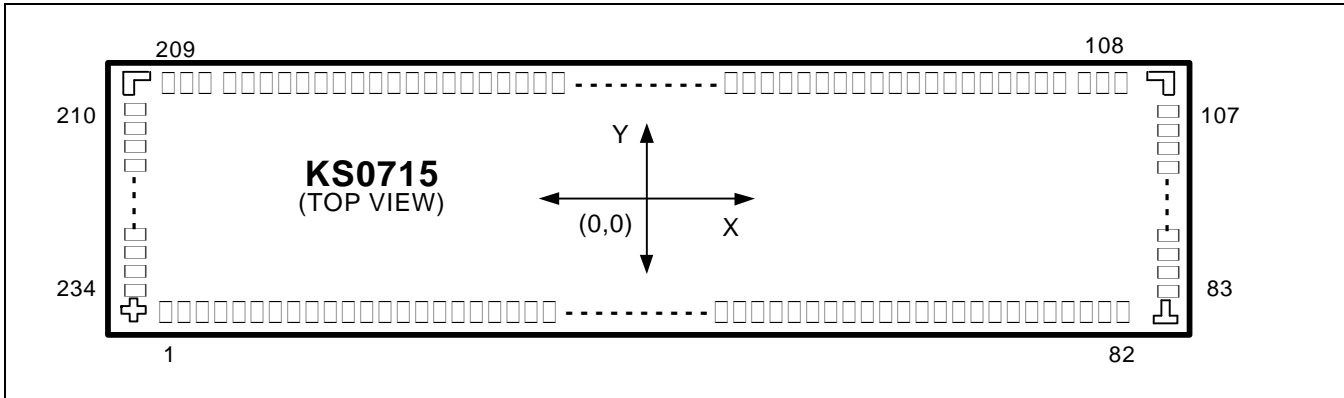
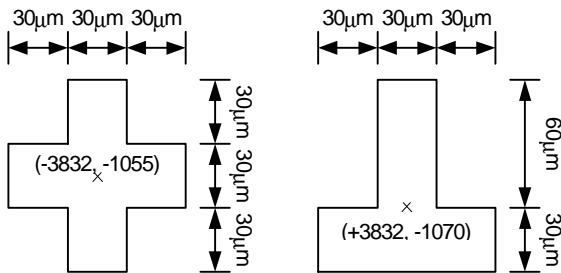

Figure 2. KS0715 Chip Configuration

Table 1. KS0715 Pad Dimensions

Item	Pad No.	Size		Unit
		X	Y	
Chip size	-	7980	2700	μm
Pad pitch	1 to 82	90		
	83 to 234	70		
Bumped pad size	1 to 82	56	114	
	83 to 107	108	50	
	108 to 209	50	108	
	210 to 234	108	50	
Bumped pad height	All pad	17 (Typ.)		

COG Align Key Coordinate



ILB Align Key Coordinate

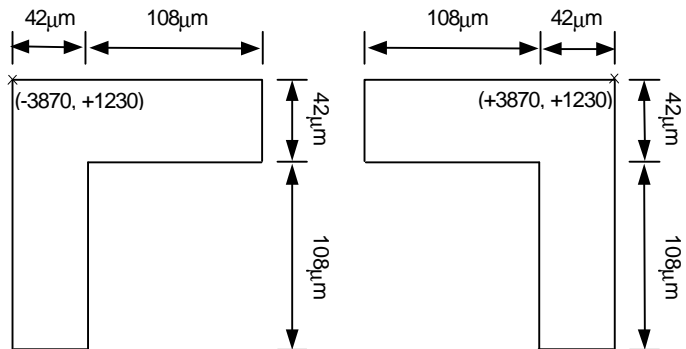

PAD CENTER COORDINATES

Table 2. Pad Center Coordinates

[Unit: μm]											
No.	Name	X	Y	No.	Name	X	Y	No.	Name	X	Y
1	DUMMY	-3645	-1226	51	C1+	855	-1226	101	COM1	3830	420
2	TESTL1	-3555	-1226	52	C1+	945	-1226	102	COM0	3830	490
3	VDD	-3465	-1226	53	C1-	1035	-1226	103	COMS	3830	560
4	FRS	-3375	-1226	54	C1-	1125	-1226	104	DUMMY	3830	630
5	M	-3285	-1226	55	C2+	1215	-1226	105	DUMMY	3830	700
6	CL	-3195	-1226	56	C2+	1305	-1226	106	DUMMY	3830	770
7	DISP	-3105	-1226	57	C2-	1395	-1226	107	DUMMY	3830	840
8	VDD	-3015	-1226	58	C2-	1485	-1226	108	DUMMY	3535	1190
9	MS	-2925	-1226	59	VSS	1575	-1226	109	SEG0	3465	1190
10	VSS	-2835	-1226	60	VSS	1665	-1226	110	SEG1	3395	1190
11	RESETB	-2745	-1226	61	VR	1755	-1226	111	SEG2	3325	1190
12	VDD	-2655	-1226	62	VR	1845	-1226	112	SEG3	3255	1190
13	PS	-2565	-1226	63	V0	1935	-1226	113	SEG4	3185	1190
14	VSS	-2475	-1226	64	V0	2025	-1226	114	SEG5	3115	1190
15	CS1B	-2385	-1226	65	V0	2115	-1226	115	SEG6	3045	1190
16	CS2	-2295	-1226	66	V0	2205	-1226	116	SEG7	2975	1190
17	VDD	-2205	-1226	67	V0	2295	-1226	117	SEG8	2905	1190
18	MI	-2115	-1226	68	V0	2385	-1226	118	SEG9	2835	1190
19	VSS	-2025	-1226	69	V1	2475	-1226	119	SEG10	2765	1190
20	VDD	-1935	-1226	70	V1	2565	-1226	120	SEG11	2695	1190
21	RS	-1845	-1226	71	V2	2655	-1226	121	SEG12	2625	1190
22	VSS	-1755	-1226	72	V2	2745	-1226	122	SEG13	2555	1190
23	RW_WR	-1665	-1226	73	V3	2835	-1226	123	SEG14	2485	1190
24	E_RD	-1575	-1226	74	V3	2925	-1226	124	SEG15	2415	1190
25	VDD	-1485	-1226	75	V4	3015	-1226	125	SEG16	2345	1190
26	VDD	-1395	-1226	76	V4	3105	-1226	126	SEG17	2275	1190
27	VDD	-1305	-1226	77	VSS	3195	-1226	127	SEG18	2205	1190
28	VDD	-1215	-1226	78	VSS	3285	-1226	128	SEG19	2135	1190
29	VDD	-1125	-1226	79	TEMPS	3375	-1226	129	SEG20	2065	1190
30	VDD	-1035	-1226	80	VDD	3465	-1226	130	SEG21	1995	1190
31	DB0	-945	-1226	81	TESTL2	3555	-1226	131	SEG22	1925	1190
32	DB1	-855	-1226	82	DUMMY	3645	-1226	132	SEG23	1855	1190
33	DB2	-765	-1226	83	DUMMY	3830	-840	133	SEG24	1785	1190
34	DB3	-675	-1226	84	DUMMY	3830	-770	134	SEG25	1715	1190
35	DB4	-585	-1226	85	DUMMY	3830	-700	135	SEG26	1645	1190
36	DB5	-495	-1226	86	DUMMY	3830	-630	136	SEG27	1575	1190
37	DB6	-405	-1226	87	COM15	3830	-560	137	SEG28	1505	1190
38	DB7	-315	-1226	88	COM14	3830	-490	138	SEG29	1435	1190
39	VSS	-225	-1226	89	COM13	3830	-420	139	SEG30	1365	1190
40	VSS	-135	-1226	90	COM12	3830	-350	140	SEG31	1295	1190
41	VSS	-45	-1226	91	COM11	3830	-280	141	SEG32	1225	1190
42	VSS	45	-1226	92	COM10	3830	-210	142	SEG33	1155	1190
43	VSS	135	-1226	93	COM9	3830	-140	143	SEG34	1085	1190
44	VSS	225	-1226	94	COM8	3830	-70	144	SEG35	1015	1190
45	VOUT	315	-1226	95	COM7	3830	0	145	SEG36	945	1190
46	VOUT	405	-1226	96	COM6	3830	70	146	SEG37	875	1190
47	C3+	495	-1226	97	COM5	3830	140	147	SEG38	805	1190
48	C3+	585	-1226	98	COM4	3830	210	148	SEG39	735	1190
49	C3-	675	-1226	99	COM3	3830	280	149	SEG40	665	1190
50	C3-	765	-1226	100	COM2	3830	350	150	SEG41	595	1190

Table 2. Pad Center Coordinates (Continued)

[Unit: μm]

No.	Name	X	Y	No.	Name	X	Y	No.	Name	X	Y
151	SEG42	525	1190	201	SEG92	-2975	1190				
152	SEG43	455	1190	202	SEG93	-3045	1190				
153	SEG44	385	1190	203	SEG94	-3115	1190				
154	SEG45	315	1190	204	SEG95	-3185	1190				
155	SEG46	245	1190	205	SEG96	-3255	1190				
156	SEG47	175	1190	206	SEG97	-3325	1190				
157	SEG48	105	1190	207	SEG98	-3395	1190				
158	SEG49	35	1190	208	SEG99	-3465	1190				
159	SEG50	-35	1190	209	DUMMY	-3535	1190				
160	SEG51	-105	1190	210	DUMMY	-3830	840				
161	SEG52	-175	1190	211	DUMMY	-3830	770				
162	SEG53	-245	1190	212	DUMMY	-3830	700				
163	SEG54	-315	1190	213	DUMMY	-3830	630				
164	SEG55	-385	1190	214	COM16	-3830	560				
165	SEG56	-455	1190	215	COM17	-3830	490				
166	SEG57	-525	1190	216	COM18	-3830	420				
167	SEG58	-595	1190	217	COM19	-3830	350				
168	SEG59	-665	1190	218	COM20	-3830	280				
169	SEG60	-735	1190	219	COM21	-3830	210				
170	SEG61	-805	1190	220	COM22	-3830	140				
171	SEG62	-875	1190	221	COM23	-3830	70				
172	SEG63	-945	1190	222	COM24	-3830	0				
173	SEG64	-1015	1190	223	COM25	-3830	-70				
174	SEG65	-1085	1190	224	COM26	-3830	-140				
175	SEG66	-1155	1190	225	COM27	-3830	-210				
176	SEG67	-1225	1190	226	COM28	-3830	-280				
177	SEG68	-1295	1190	227	COM29	-3830	-350				
178	SEG69	-1365	1190	228	COM30	-3830	-420				
179	SEG70	-1435	1190	229	COM31	-3830	-490				
180	SEG71	-1505	1190	230	COMS	-3830	-560				
181	SEG72	-1575	1190	231	DUMMY	-3830	-630				
182	SEG73	-1645	1190	232	DUMMY	-3830	-700				
183	SEG74	-1715	1190	233	DUMMY	-3830	-770				
184	SEG75	-1785	1190	234	DUMMY	-3830	-840				
185	SEG76	-1855	1190								
186	SEG77	-1925	1190								
187	SEG78	-1995	1190								
188	SEG79	-2065	1190								
189	SEG80	-2135	1190								
190	SEG81	-2205	1190								
191	SEG82	-2275	1190								
192	SEG83	-2345	1190								
193	SEG84	-2415	1190								
194	SEG85	-2485	1190								
195	SEG86	-2555	1190								
196	SEG87	-2625	1190								
197	SEG88	-2695	1190								
198	SEG89	-2765	1190								
199	SEG90	-2835	1190								
200	SEG91	-2905	1190								

PIN DESCRIPTION

POWER SUPPLY

Table 3. Power Supply Pin Description

Name	I/O	Description															
VDD	Supply	Power supply															
VSS	Supply	Ground															
V0 V1 V2 V3 V4	I/O	<p>LCD driver supply voltages The voltage determined by LCD pixel is impedance-converted by an operational amplifier for application. Voltages should have the following relationship; $V0 \geq V1 \geq V2 \geq V3 \geq V4 \geq VSS$ When the internal power circuit is active, these voltages are generated as following table according to the state of LCD Bias.</p> <table border="1"> <thead> <tr> <th>LCD bias</th> <th>V1</th> <th>V2</th> <th>V3</th> <th>V4</th> </tr> </thead> <tbody> <tr> <td>1/6 bias</td> <td>$(5/6) \times V0$</td> <td>$(4/6) \times V0$</td> <td>$(2/6) \times V0$</td> <td>$(1/6) \times V0$</td> </tr> <tr> <td>1/5 bias</td> <td>$(4/5) \times V0$</td> <td>$(3/5) \times V0$</td> <td>$(2/5) \times V0$</td> <td>$(1/5) \times V0$</td> </tr> </tbody> </table>	LCD bias	V1	V2	V3	V4	1/6 bias	$(5/6) \times V0$	$(4/6) \times V0$	$(2/6) \times V0$	$(1/6) \times V0$	1/5 bias	$(4/5) \times V0$	$(3/5) \times V0$	$(2/5) \times V0$	$(1/5) \times V0$
LCD bias	V1	V2	V3	V4													
1/6 bias	$(5/6) \times V0$	$(4/6) \times V0$	$(2/6) \times V0$	$(1/6) \times V0$													
1/5 bias	$(4/5) \times V0$	$(3/5) \times V0$	$(2/5) \times V0$	$(1/5) \times V0$													

LCD DRIVER SUPPLY

Table 4. LCD Driver Supply Pin Description

Name	I/O	Description
C1-	O	Capacitor 1 negative connection pin for voltage converter
C1+	O	Capacitor 1 positive connection pin for voltage converter
C2-	O	Capacitor 2 negative connection pin for voltage converter
C2+	O	Capacitor 2 positive connection pin for voltage converter
C3-	O	Capacitor 3 negative connection pin for voltage converter
C3+	O	Capacitor 3 positive connection pin for voltage converter
VOUT	I/O	Voltage converter input / output pin
VR	I	V0 voltage adjustment pin

SYSTEM CONTROL

Table 5. System Control Pin Description

Name	I/O	Description						
MS	I	Master / Slave operation select pin – MS = "H": master operation – MS = "L": slave operation The following table depends on the MS status.						
		MS	OSC circuit	Power supply circuit	CL	M	FRS	DISP
		H	Enabled	Input	Output	Output	Output	Output
		L	Disabled	Disabled	Input	Input	Output	Input
CL	I/O	Display clock input / output pin When the KS0715 is used in master/slave mode (multi-chip), the CL pins must be connected each other for sync.						
M	I/O	LCD AC signal input / output pin When the KS0715 is used in master/slave mode (multi-chip), the M pins must be connected each other. – MS = "H": output – MS = "L": input						
FRS	O	Static driver segment output pin This pin is used together with the M pin.						
DISP	I/O	LCD display blanking control input/output. When KS0715 is used in master/slave mode (multi-chip), the DISP pins must be connected each other. – MS = "H": output – MS = "L": input						
TEMPS	I	Selects temperature coefficient of the reference voltage – TEMPS = "L": -0.05%/°C – TEMPS = "H": -0.2%/°C						

MICROPROCESSOR INTERFACE

Table 6. Microprocessor Interface Pin Description

Name	I/O	Description						
RESETB	I	Reset input pin When RESETB is "L", initialization is executed.						
PS	I	Parallel / serial data input select input						
		PS	Interface mode	Chip select	Data / instruction	Data	Read / write	Serial clock
		H	Parallel	CS1B, CS2	RS	DB0 to DB7	E_RD RW_WR	-
		L	Serial	CS1B, CS2	RS	SID (DB7)	Write only	SCLK (DB6)
*NOTE: When PS is "L", DB0 to DB5 are high impedance and E_RD and RW_WR should be fixed to either "H" or "L".								
MI	I	Microprocessor interface select input pin – MI = "H": 6800-series MPU interface – MI = "L": 8080-series MPU interface						
CS1B CS2	I	Chip select input pins Data / instruction I/O is enabled only when CS1B is "L" and CS2 is "H". When chip select is non-active, DB0 to DB7 may be high impedance.						
RS	I	Register select input pin – RS = "H": DB0 to DB7 are display data. – RS = "L": DB0 to DB7 are control data.						
RW_WR	I	Read / Write execution control pin						
		MI	MPU type	RW_WR	Description			
		H	6800-series	RW	Read/Write control input pin – RW = "H": read – RW = "L": write			
		L	8080-series	/WR	Write enable clock input pin The data on DB0 to DB7 are latched at the rising edge of the /WR signal.			

Table 6. Microprocessor Interface Pin Description (Continued)

Name	I/O	Description			
E_RD	I	Read / Write execution control pin			
		MI	MPU Type	E_RD	Description
		H	6800-series	E	Read / Write control input pin – RW = "H": When E is "H", DB0 to DB7 are in an output status. – RW = "L": The data on DB0 to DB7 are latched at the falling edge of the E signal.
		L	8080-series	/RD	Read enable clock input pin When /RD is "L", DB0 to DB7 are in an output status.
DB0 to DB7	I/O	8-bit bi-directional data bus that is connected to the standard 8-bit microprocessor data bus. When the serial interface selected (PS = "L"); – DB0 to DB5: high impedance – DB6: serial input clock (SCLK) – DB7: serial input data (SID) When chip select is not active, DB0 to DB7 may be high impedance.			

LCD DRIVER OUTPUTS

Table 8. LCD Driver Outputs Pin Description

Name	I/O	Description			
SEG0 to SEG99	O	LCD segment driver outputs The display data and the M signal control the output voltage of segment driver.			
		Display data	M	Segment driver output voltage	
				Normal display	Reverse display
		H	H	V0	V2
		H	L	Vss	V3
		L	H	V2	V0
		L	L	V3	Vss
		Power save mode		Vss	Vss
COM0 to COM31	O	LCD common driver outputs The internal scanning data and M signal control the output voltage of common driver.			
		Scan data	M	Common driver output voltage	
		H	H	Vss	
		H	L	V0	
		L	H	V1	
		L	L	V4	
		Power save mode		Vss	
COMS	O	Common output for the icons The output signals of two pins are same. When not used, these pins should be left open. In multi-chip (master/slave) mode, all COMS pins on both master and slave units are the same signal.			

TEST PINS

Table 8. Test Pin Description

Name	I/O	Description
TESTL1 TESTL2	I	IC test pins with pull-up These pins must be open.

NOTE: **DUMMY** – These pins should be opened (floated).

FUNCTIONAL DESCRIPTION

MICROPROCESSOR INTERFACE

Chip Select Input

There are CS1B and CS2 pins for Chip Selection. The KS0715 can interface with an MPU only when CS1B is "L" and CS2 is "H". When these pins are set to any other combination, RS, E_RD, and RW_WR inputs are disabled and DB0 to DB7 are to be high impedance. And, in case of serial interface, the internal shift register and the counter are reset.

Parallel / Serial Interface

KS0715 has three types of interface with an MPU, which are one serial and two parallel interface. This parallel or serial interface is determined by PS pin as shown in table 9.

Table 9. Parallel / Serial Interface Mode

PS	Type	CS1B	CS2	MI	Interface mode
H	Parallel	CS1B	CS2	H	6800-series MPU mode
				L	8080-series MPU mode
L	Serial	CS1B	CS2	*x	Serial-mode

*x: Don't care

Parallel Interface (PS = "H")

The 8-bit bi-directional data bus is used in parallel interface and the type of MPU is selected by MI as shown in table 10. The type of data transfer is determined by signals at RS, E_RD and RW_WR as shown in table 11.

Table 10. Microprocessor Selection for Parallel Interface

MI	CS1B	CS2	RS	E_RD	RW_WR	DB0 to DB7	MPU bus
H	CS1B	CS2	RS	E	RW	DB0 to DB7	6800-series
L	CS1B	CS2	RS	/RD	/WR	DB0 to DB7	8080-series

Table 11. Parallel Data Transfer

Common	6800-series		8080-series		Description
	E_RD (E)	RW_WR (RW)	E_RD (/RD)	RW_WR (/WR)	
RS					
H	H	H	L	H	Display data read out
H	H	L	H	L	Display data write
L	H	H	L	H	Register status read
L	H	L	H	L	Writes to internal register (instruction)

Serial interface (PS = "L")

When the KS0715 is active, serial data (DB7) and serial clock (DB6) inputs are enabled. And not active, the internal 8-bit shift register and the 3-bit counter are reset. Serial data can be read on the rising edge of serial clock going into DB6 and processed as 8-bit parallel data on the eighth serial clock. Serial data input is display data when RS is high and control data when RS is low. Since the clock signal (DB6) is easy to be affected by the external noise caused by the line length, the operation check on the actual machine is recommended.

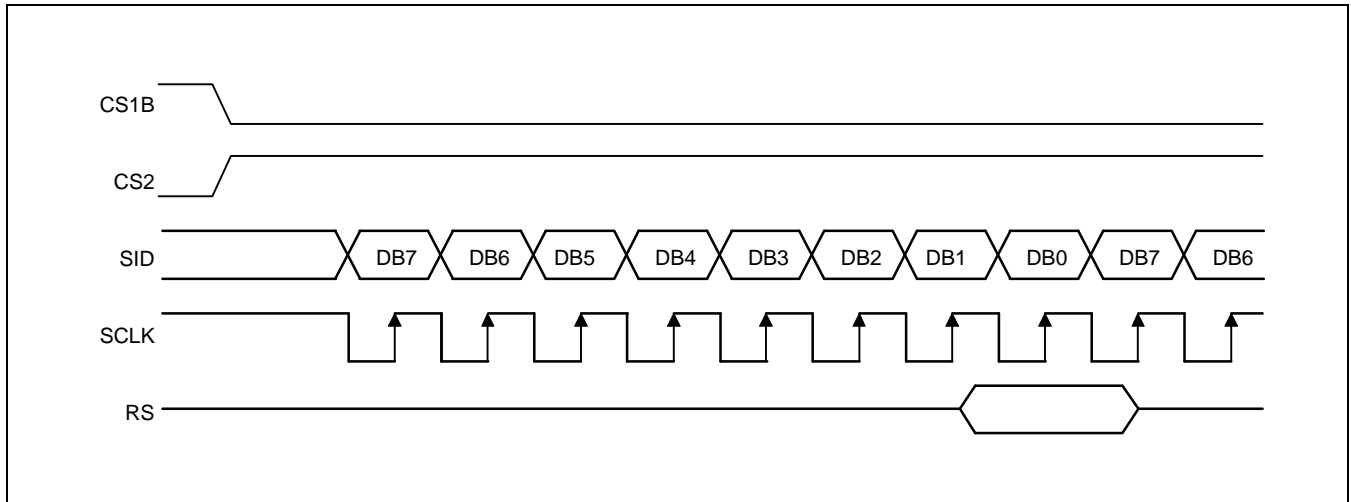

Figure 3. Serial Interface Timing

Busy Flag

The Busy Flag indicates whether the KS0715 is operating or not. When DB7 is "H" in read status operation, this device is in busy status and will accept only read status instruction. If the cycle time is correct, the microprocessor needs not to check this flag before each instruction, which improves the MPU performance.

Data Transfer

The KS0715 uses bus holder and internal data bus for Data Transfer with the MPU. When writing data from the MPU to on-chip RAM, data is automatically transferred from the bus holder to the RAM as shown in figure 4. And when reading data from on-chip RAM to the MPU, the data for the initial read cycle is stored in the bus holder (dummy read) and the MPU reads this stored data from bus holder for the next data read cycle as shown in figure 5. This means that a dummy read cycle must be inserted between each pair of address sets when a sequence of address sets is executed. Therefore, the data of the specified address cannot be output with the read display data instruction right after the address sets, but can be output at the second read of data.

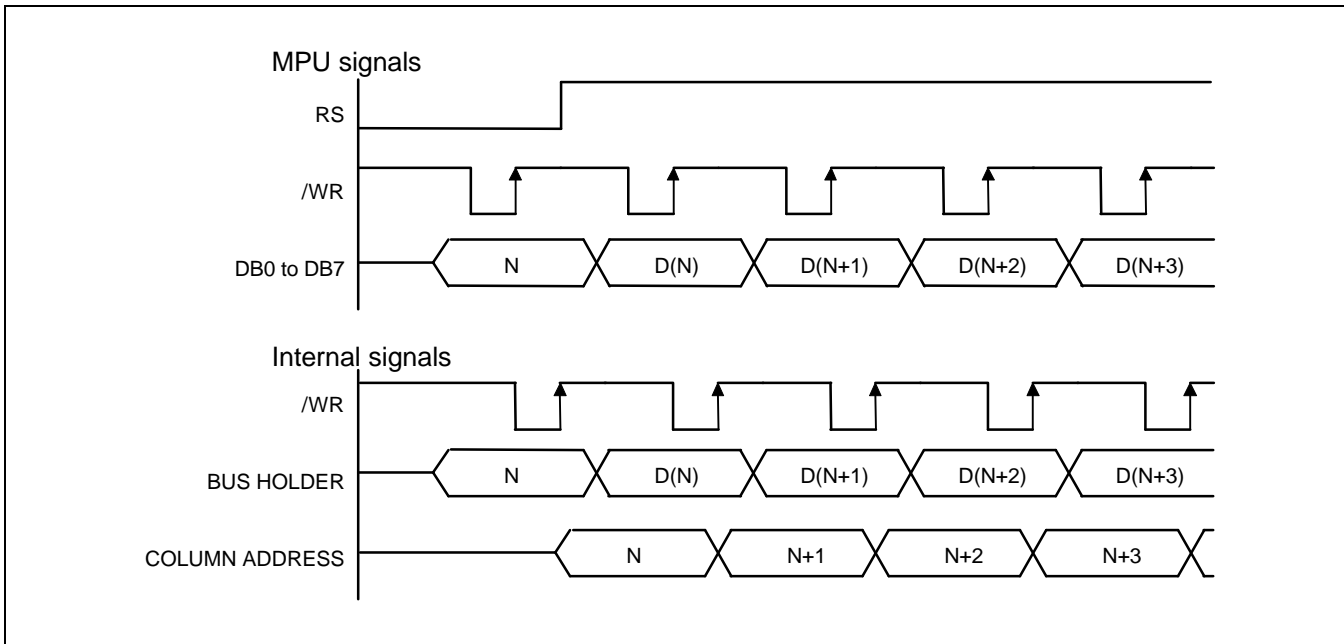

Figure 4. Write Timing

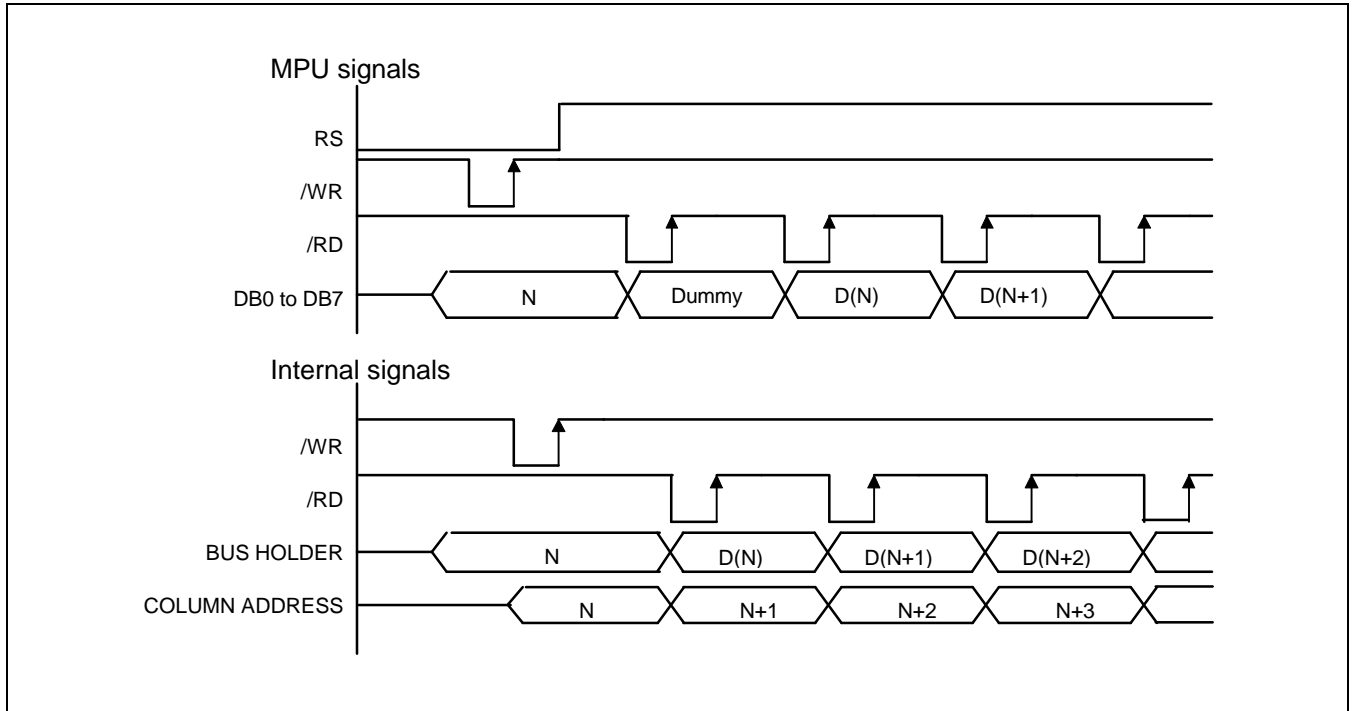

Figure 5. Read Timing

Column Address Circuit

Column Address circuit has an 8-bit preset counter that provides column address to the Display Data RAM as shown in figure 8. When set Column Address MSB / LSB instruction is issued, 8-bit [Y7:Y0] is updated. And, since this address is increased by 1 each a read or write Data instruction, microprocessor can access the display data continuously. However, the counter is not increased and locked if a non-existing address above 84H. It is unlocked if a column address is set again by set Column Address MSB / LSB instruction. And the column address counter is independent of page address register.

ADC select instruction makes it possible to invert the relationship between the column address and the segment outputs. It is necessary to rewrite the display data on built-in RAM after issuing ADC select instruction. Refer to the following figure 7.

SEG output	-	SEG 0	SEG 1	SEG 2	SEG 97	SEG 98	SEG 99	-
Column address [Y7:Y0]	00H~0FH	10H	01H	02H	71H	72H	73H	74H~83H
Display data	×	1	0	0		0	1	1	0
LCD panel display (ADC = 0)	Not outputted							Not outputted
LCD panel display (ADC = 1)	Not outputted							Not outputted

Figure 7. The Relationship between the Column Address and the Segment Outputs

Segment Control Circuit

This circuit controls the display data by the display ON / OFF, reverse display ON / OFF and entire display ON / OFF instructions without changing the data in the display data RAM.

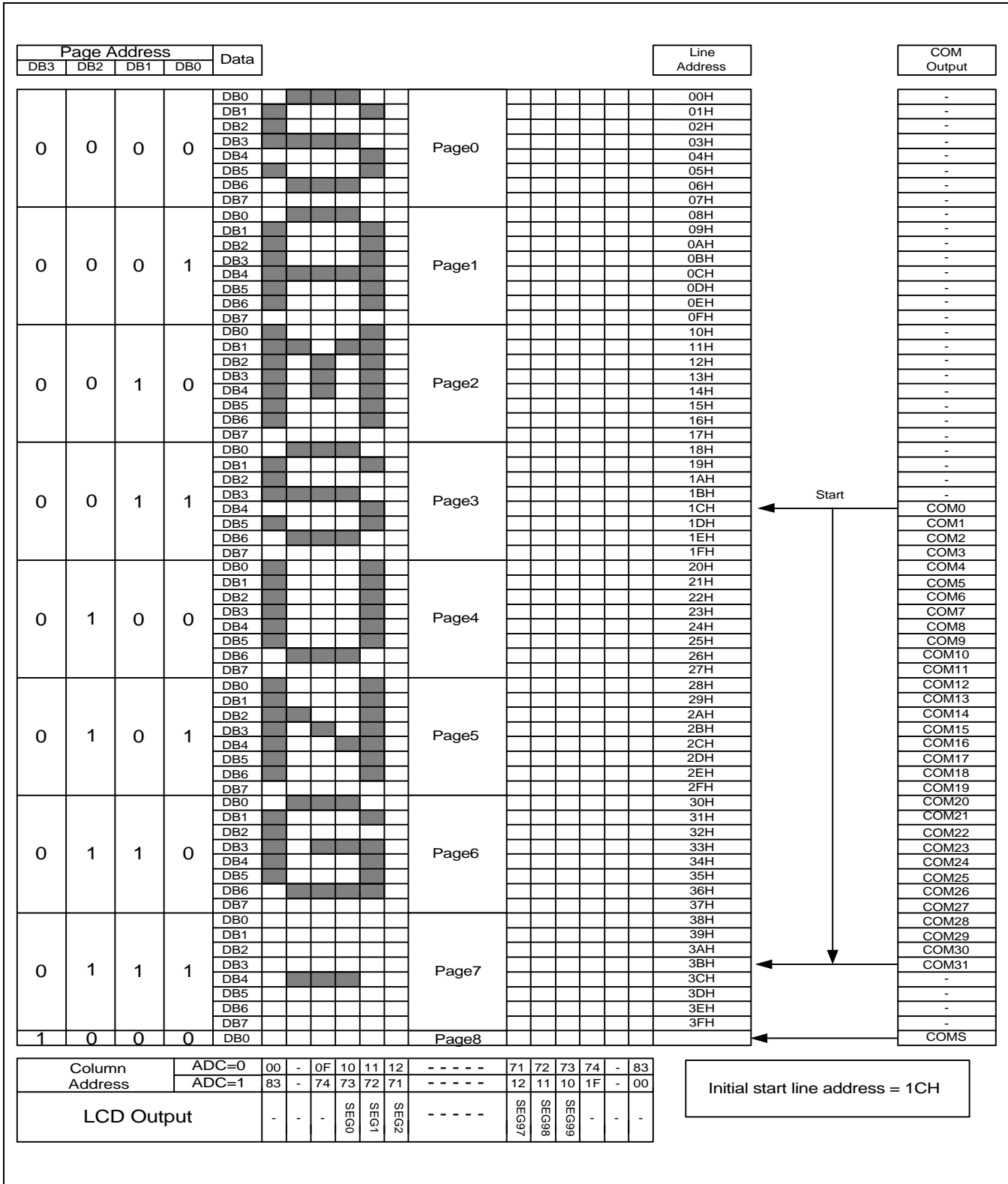

Figure 8. Display Data RAM Map

LCD DISPLAY CIRCUITS

Oscillator

This is completely on-chip Oscillator and its frequency is nearly independent of VDD. This oscillator signal is used in the voltage converter and display timing generation circuit.

* Test Condition: Temperature: 25°C & 85°C, TEMPS = "L", No Load

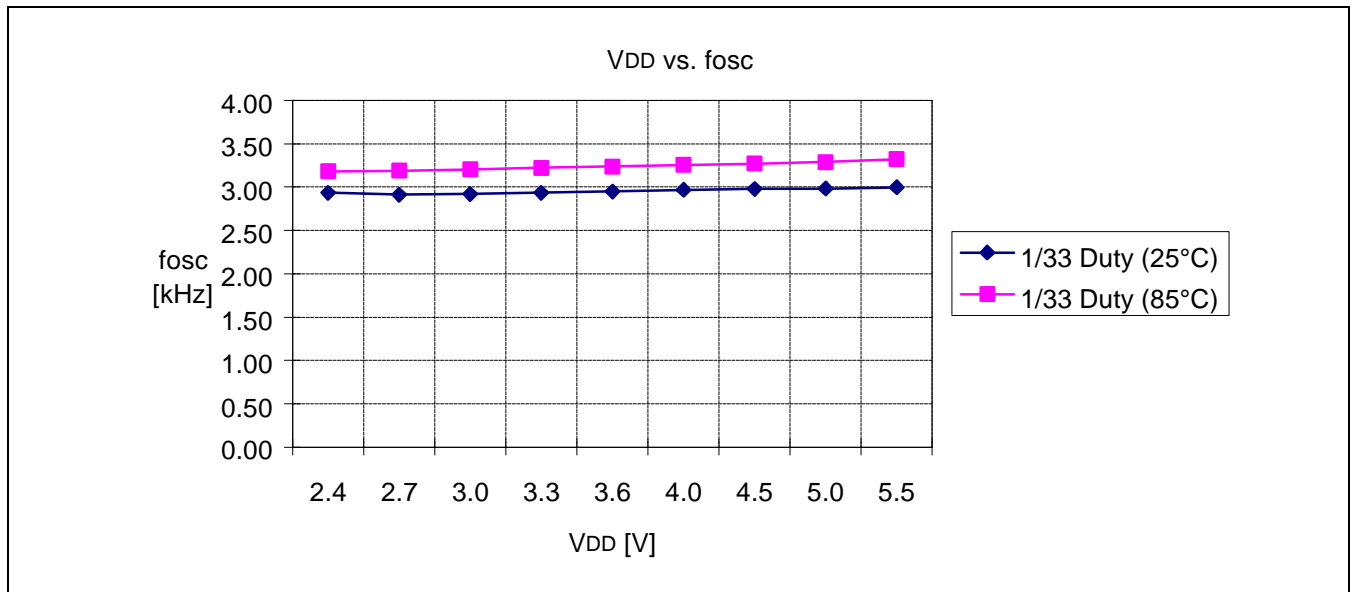

Figure 9. VDD vs. fosc

Display Timing Generator Circuit

This circuit generates some signals to be used for displaying LCD. The display clock, CL, generated by oscillation clock, generates the clock for the line counter and the signal for the display data latch. The line address of on-chip RAM is generated in synchronization with the display clock (CL) and the 100-bit display data is latched by the display data latch circuit in synchronization with the display clock. The display data, which is read to the LCD driver, is completely independent of the access to the display data RAM from the microprocessor. The display clock generates an LCD AC signal (M) which enables the LCD driver to make a AC drive waveform, and also generates an internal common timing signal and start signal to the common driver. Driving 2-frame AC driver waveform and internal timing signal are shown in figure 10.

In a multiple-chip configuration, the slave chip requires the M, CL and DISP signals from the master. Table 12 shows the M, CL, and DISP status.

Table 12. Master and Slave Timing Signal Status

Operation mode	Oscillator	M	CL	DISP
Master	ON (internal clock used)	Output	Output	Output
	OFF (external clock used)	Output	Input	Output
Slave	-	Input	Input	Input

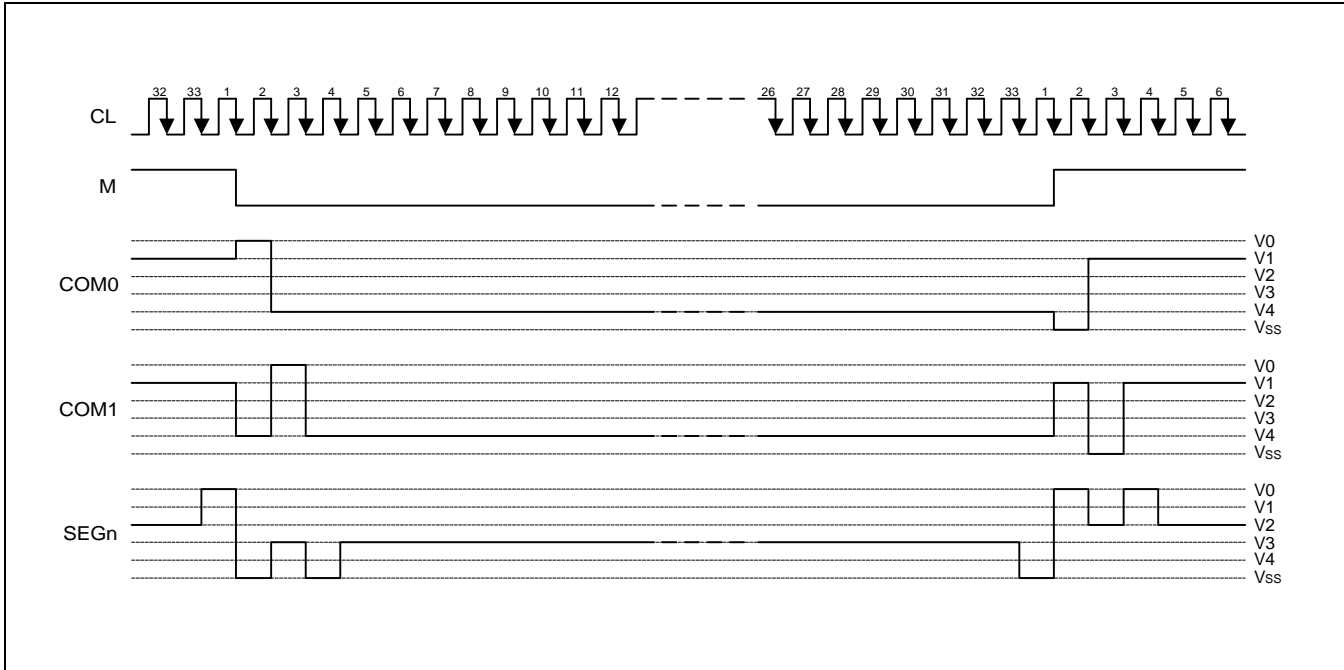

Figure 9. 2-frame AC Driving Waveform

Common Output Control Circuit

This circuit controls the relationship between the number of common output and specified duty ratio. SHL Select Instruction specifies the scanning direction of the common output pins.

Table 13. The Relationship between Duty Ratio and Common Output

Duty	SHL	Common output pins	
		COM0 to COM31	COMS
1/33	0	COM0 to COM31	COMS
	1	COM31 to COM0	

LCD DRIVER CIRCUIT

This driver circuit is configured by 34-channel (including 2 COMS channel) common driver and 100-channel segment driver. This LCD panel driver voltage depends on the combination of display data and M signal.

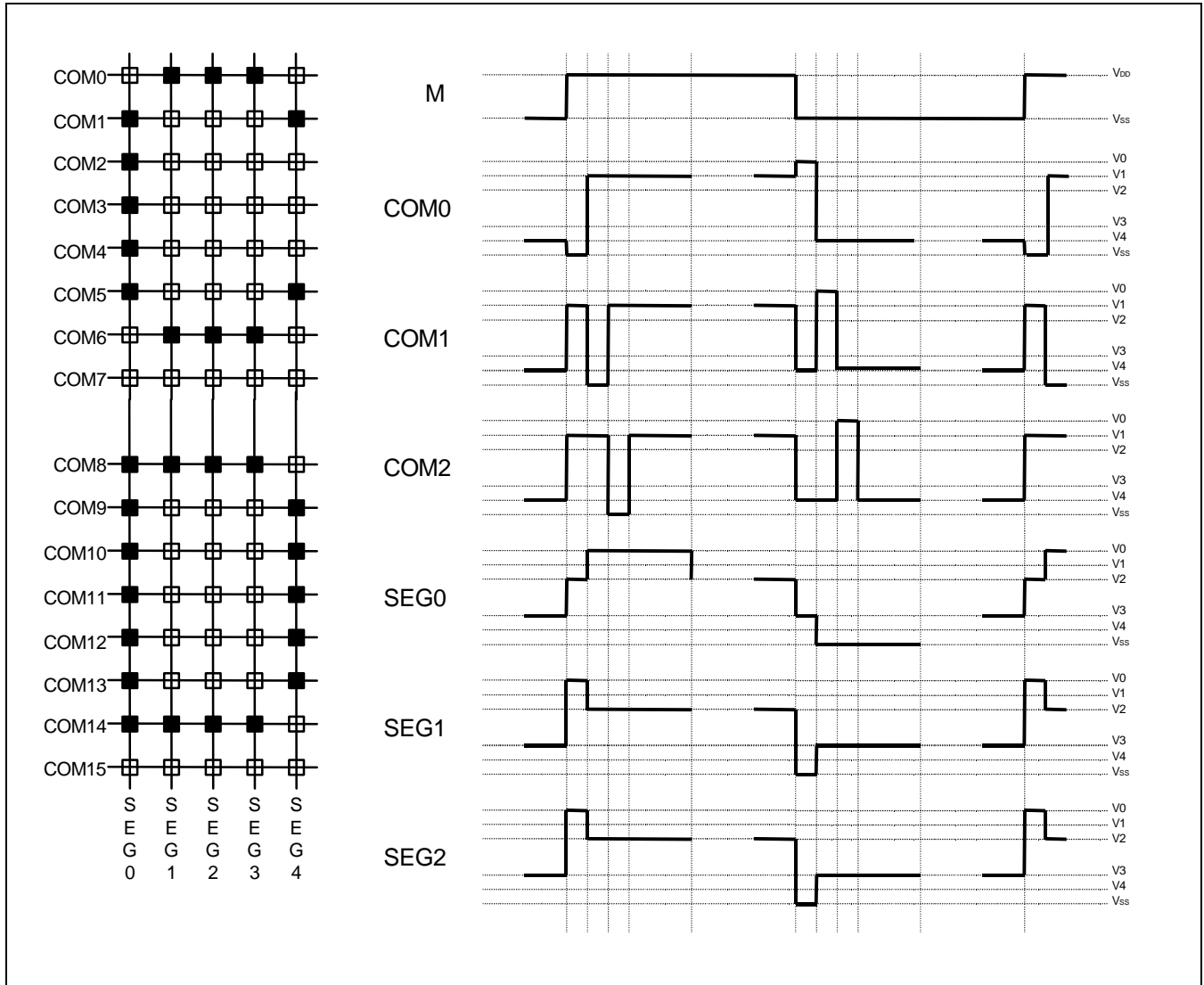

Figure 10. Segment and Common Timing

POWER SUPPLY CIRCUITS

The Power Supply circuits generate the voltage levels necessary to drive liquid crystal driver circuits with low-power consumption and the fewest components. There are voltage converter circuits, voltage regulator circuits, and voltage follower circuits. They are valid only in master operation and controlled by power control instruction. For details, refers to "Instruction Description". Table 14 shows the referenced combinations in using Power Supply circuits.

Table 14. Recommended Power Supply Combinations

User setup	Power control (VC VR VF)	V/C circuits	V/R circuits	V/F circuits	VOUT	V0	V1 to V4
Only the internal power supply circuits are used	1 1 1	ON	ON	ON	Open	Open	Open
Only the voltage regulator circuits and voltage follower circuits are used	0 1 1	OFF	ON	ON	External input	Open	Open
Only the voltage follower circuits are used	0 0 1	OFF	OFF	ON	Open	External input	Open
Only the external power supply circuits are used	0 0 0	OFF	OFF	OFF	Open	External input	External input

Voltage Converter Circuits

These circuits boost up the electric potential between VDD and VSS to 2, 3, or 4 times toward positive side and boosted voltage is outputted from VOUT pin.

[C1 = 1.0 to 4.7 nF]

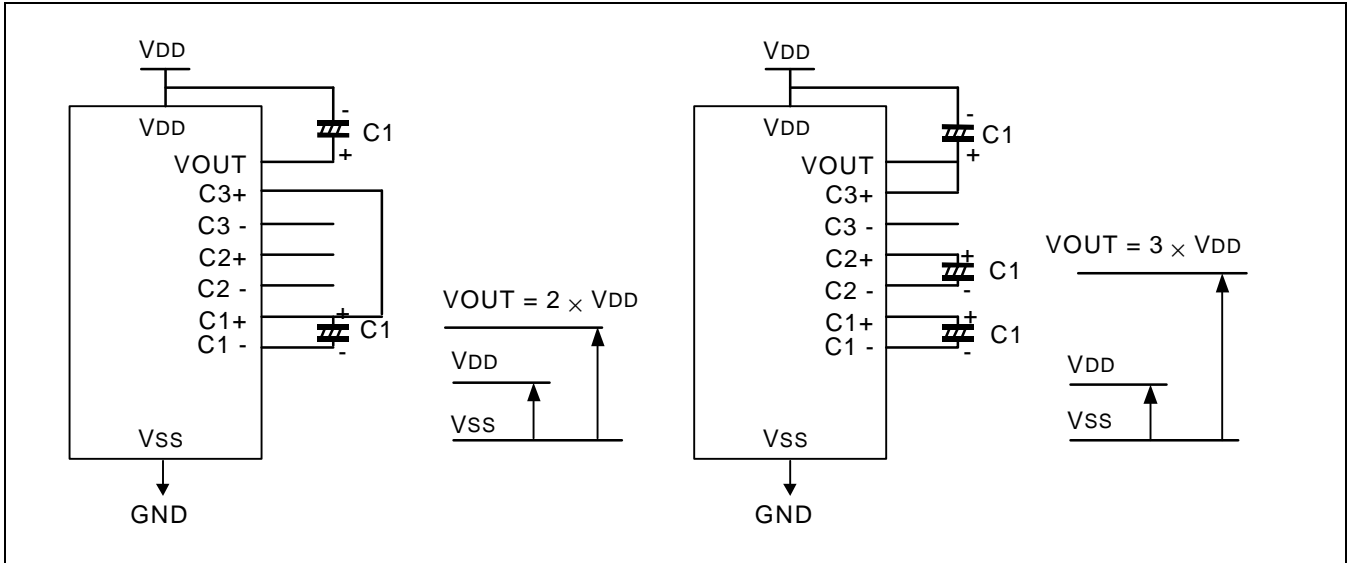

Figure 11. Two Times Boosting Circuit

Figure 12. Three Times Boosting Circuit

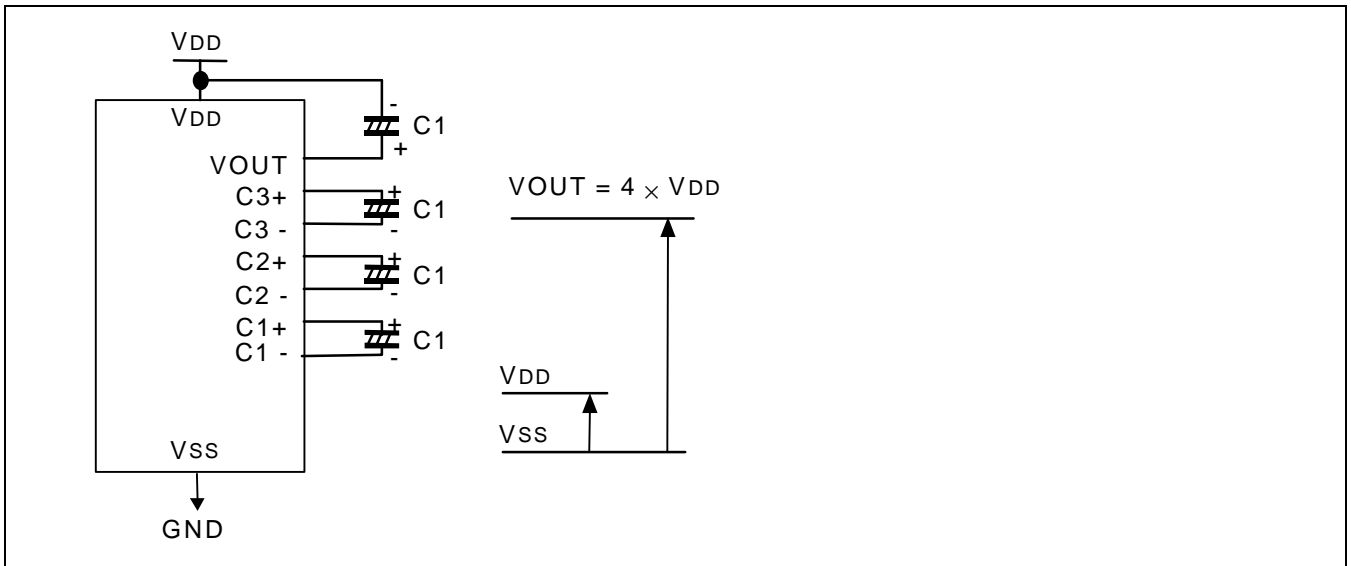

Figure 13. Four Times Boosting Circuit

Voltage Regulator Circuits

The function of the internal Voltage Regulator circuits is to determine liquid crystal operating voltage, V0, by adjusting resistors, Ra and Rb, within the range of |V0| < |VOUT|. Because VOUT is the operating voltage of operational-amplifier circuits shown in figure 14, it is necessary to be applied internally or externally.

For the **Eq. 1**, we determine V0 by Ra, Rb and VEV. The Ra and Rb are connected internally or externally by INTRS pin. And VEV called the voltage of electronic volume is determined by Eq. 2, where the parameter α is the value selected by instruction, "Set Reference Voltage Register", within the range 0 to 31. VREF voltage at Ta = 25°C is shown in table 15-1.

$$V0 = (1 + \frac{Rb}{Ra}) \times VEV \text{ [V] ----- (Eq. 1)}$$

$$VEV = (1 - \frac{(31 - \alpha)}{150}) \times VREF \text{ [V] ----- (Eq. 2)}$$

Table 15-1. VREF Voltage at Ta = 25°C

TEMPS	Temp. coefficient	VREF [V]
L	-0.05% / °C	1.9
H	-0.2% / °C	2.1

Table 15-2. Reference Voltage Parameter (α)

SV4	SV3	SV2	SV1	SV0	Reference voltage parameter (α)
0	0	0	0	0	0
0	0	0	0	1	1
:	:	:	:	:	:
:	:	:	:	:	:
1	1	1	1	0	30
1	1	1	1	1	31

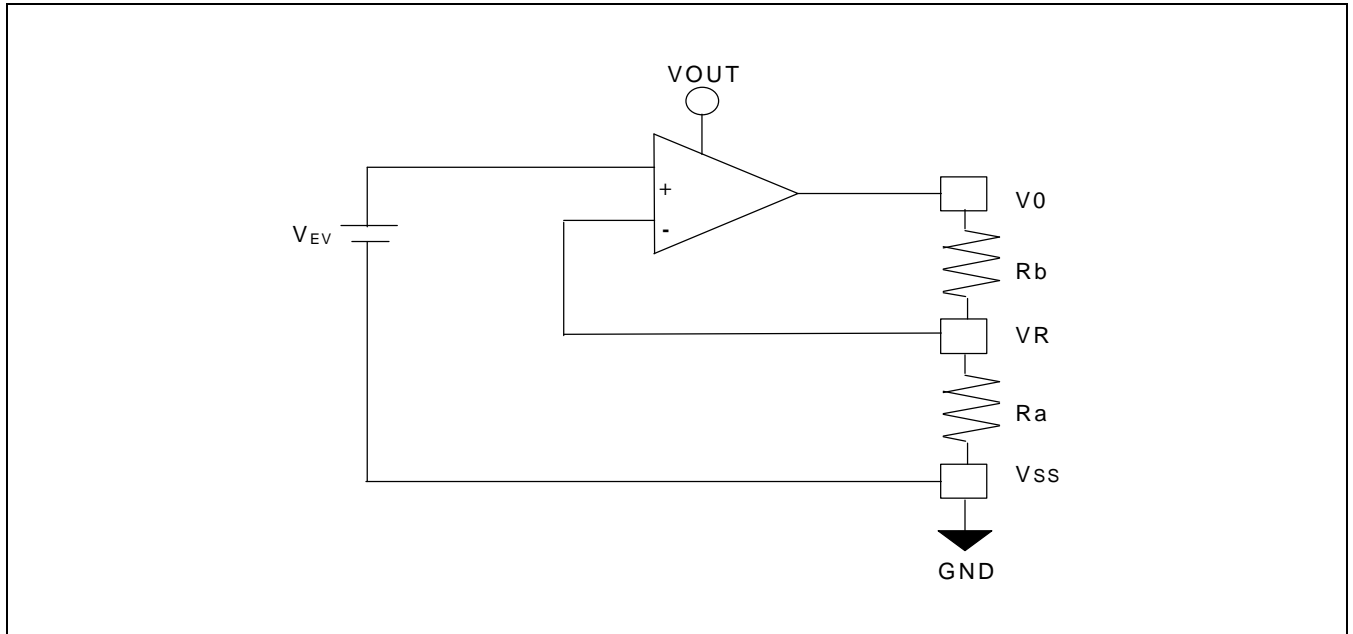

Figure 14. Internal Voltage Regulator Circuit

In Case of Using External Resistors, Ra and Rb

It is necessary to connect external regulator resistor Ra between VR and Vss, and Rb between V0 and VR.

Example: For the following requirements

1. LCD driver voltage, $V_0 = 8V$
2. 5-bit reference voltage register = (1, 1, 1, 1, 1)
3. Maximum current flowing Ra, Rb = 1 μA

From Eq. 1

$$8 = \left(1 + \frac{R_b}{R_a} \right) \times V_{EV} \text{ [V]} \text{ ----- (Eq. 3)}$$

From Eq. 2

$$V_{EV} = \left(1 - \frac{(31 - 31)}{150} \right) \times 1.9 = 1.9 \text{ [V]} \text{ ----- (Eq. 4)}$$

From requirement 3.

$$\frac{8}{R_a + R_b} = 1 \text{ [\mu A]} \text{ ----- (Eq. 5)}$$

From equations Eq. 3, 4 and 5

$$R_a = 1.9 \text{ [M}\Omega\text{]}$$

$$R_b = 6.1 \text{ [M}\Omega\text{]}$$

The following table shows the range of V0 depending on the above requirements.

Table 16. V0 depending on Electronic Volume Level

	Electronic volume level				
	0	16	31
V0	6.33	7.19	8

Voltage Follower Circuits

VLCD voltage (V_0) is resistively divided into four voltage levels (V_1 , V_2 , V_3 and V_4) and those output impedance are converted by the Voltage Follower for increasing drive capability. Table 17 shows the relationship between V_1 to V_4 level and bias.

Table 17. The Relationship between V_1 to V_4 Level and Bias

Duty ratio	LCD bias	V_1	V_2	V_3	V_4
1/33	1/6	$(5/6) \times V_0$	$(4/6) \times V_0$	$(2/6) \times V_0$	$(1/6) \times V_0$
	1/5	$(4/5) \times V_0$	$(3/5) \times V_0$	$(2/5) \times V_0$	$(1/5) \times V_0$

REFERECE CIRCUIT EXAMPLES

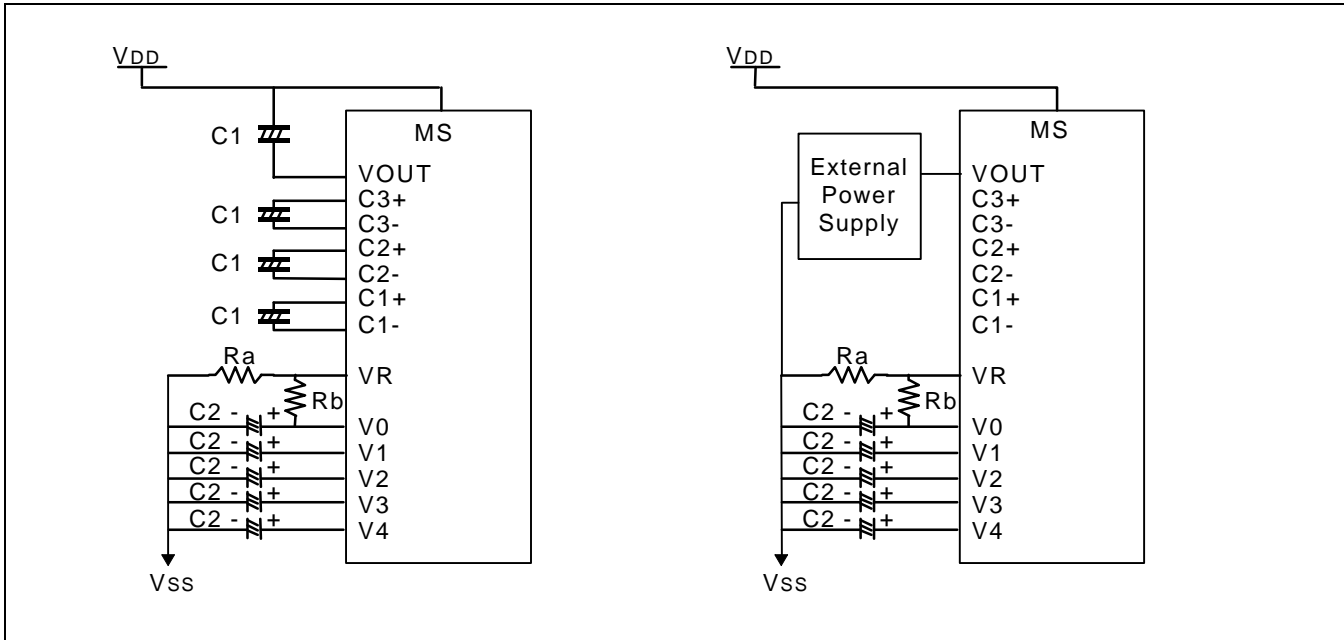

Figure 15. When Using all LCD Power Circuits
(4-time V/C: ON, V/R: ON, V/F: ON)

Figure 16. When not Using V/C Circuit

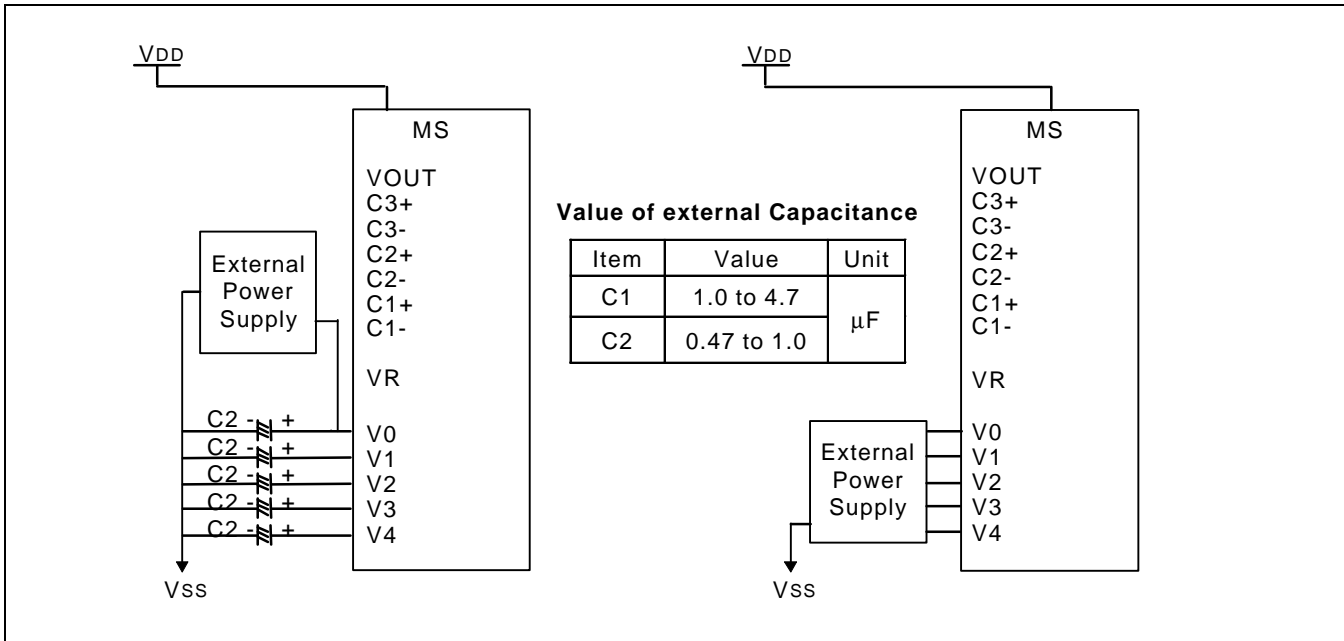

Figure 17. When Using some LCD Power Circuits
(V/C: OFF, V/R: OFF, V/F: ON)

Figure 18. When not Using Internal LCD Power Supply Circuit

RESET CIRCUIT

Setting RESETB to "L" or Reset instruction can initialize internal function.
When RESETB becomes "L", following procedure is occurred.

- Display ON / OFF: OFF
- Entire display ON / OFF: OFF (normal)
- ADC select: OFF (normal)
- Reverse display ON / OFF: OFF (normal)
- Power control register (VC, VR, VF) = (0, 0, 0)
- LCD bias ratio: 1/6
- Read-modify-write: OFF
- SHL select: OFF (normal)
- Static indicator mode: OFF
- Display start line: 0 (first)
- Column address: 0
- Page address: 0
- Reference voltage set: off
- Reference voltage control register: (SV4, SV3, SV2, SV1, SV0) = (0, 0, 0, 0, 0)

When RESET instruction is issued, following procedure is occurred.

- Read-modify-write: OFF
- Static indicator mode: OFF
- SHL select: 0
- Display start line: 0 (first)
- Column address: 0
- Page address: 0
- Reference voltage set: OFF
- Reference voltage control register: (SV4, SV3, SV2, SV1, SV0) = (0, 0, 0, 0, 0)

While RESETB is "L" or reset instruction is executed, no instruction except read status could be accepted. Reset status appears at DB4. After DB4 becomes "L", any instruction can be accepted. RESETB must be connected to the reset pin of the MPU, and initialize the MPU and this LSI at the same time. The initialization by RESETB is essential before used.

INSTRUCTION DESCRIPTION

Table 18. Instruction Table

× : Don't care

Instruction	RS	RW	DB7	DB6	DB5	DB4	DB3	DB2	DB1	DB0	Description
Read display data	1	1	Read data								Read data from DDRAM
Write display data	1	0	Write data								Write data into DDRAM
Read status	0	1	BUSY	ADC	ONOFF	RESETB	0	0	0	0	Read the internal status
Display ON / OFF	0	0	1	0	1	0	1	1	1	DON	Turn ON / OFF LCD panel When DON = 0: display OFF When DON = 1: display ON
Initial display line	0	0	0	1	ST5	ST4	ST3	ST2	ST1	ST0	Specify DDRAM line for COM0
Set reference voltage mode	0	0	1	0	0	0	0	0	0	1	Set reference voltage mode
Set reference voltage register	0	0	1	0	0	SV4	SV3	SV2	SV1	SV0	Set reference voltage register
Set page address	0	0	1	0	1	1	P3	P2	P1	P0	Set page address
Set column address MSB	0	0	0	0	0	1	0	Y6	Y5	Y4	Set column address MSB
Set column address LSB	0	0	0	0	0	0	Y3	Y2	Y1	Y0	Set column address LSB
ADC select	0	0	1	0	1	0	0	0	0	ADC	Select SEG output direction When ADC = 0: normal direction (SEG0→SEG99) When ADC = 1: reverse direction (SEG99→SEG0)
Reverse display ON / OFF	0	0	1	0	1	0	0	1	1	REV	Select normal / reverse display When REV = 0: normal display When REV = 1: reverse display
Entire display ON / OFF	0	0	1	0	1	0	0	1	0	EON	Select normal/ entire display ON When EON = 0: normal display. When EON = 1: entire display ON
LCD bias select	0	0	1	0	1	0	0	0	1	BIAS	Select LCD bias
Set modify-read	0	0	1	1	1	0	0	0	0	0	Set modify-read mode
Reset modify-read	0	0	1	1	1	0	1	1	1	0	release modify-read mode
Reset	0	0	1	1	1	0	0	0	1	0	Initialize the internal functions
SHL select	0	0	1	1	0	0	SHL	×	×	×	Select COM output direction When SHL = 0: normal direction (COM0→COM31) When SHL = 1: reverse direction (COM31→COM0)
Power control	0	0	0	0	1	0	1	VC	VR	VF	Control power circuit operation
Set static indicator register	0	0	1	0	1	0	1	1	0	SI	Set static indicator register SI = 0 (OFF), SI = 1 (ON)
Power save	-	-	-	-	-	-	-	-	-	-	Compound instruction of display OFF and entire display ON
Test instruction	0	0	1	1	1	1	×	×	×	×	<i>Don't use this instruction.</i>

Read Display Data

8-bit data from Display Data RAM specified by the column address and page address could be read by this instruction. As the column address is increased by 1 automatically after each this instruction, the microprocessor can continuously read data from the addressed page. A dummy read is required after loading an address into the column address register. Display data cannot be read through the serial interface.

RS	RW	DB7	DB6	DB5	DB4	DB3	DB2	DB1	DB0
1	1	Read data							

Write Display Data

8-bit data of display data from the microprocessor can be written to the RAM location specified by the column address and page address. The column address is increased by 1 automatically so that the microprocessor can continuously write data to the addressed page.

RS	RW	DB7	DB6	DB5	DB4	DB3	DB2	DB1	DB0
1	0	Write data							

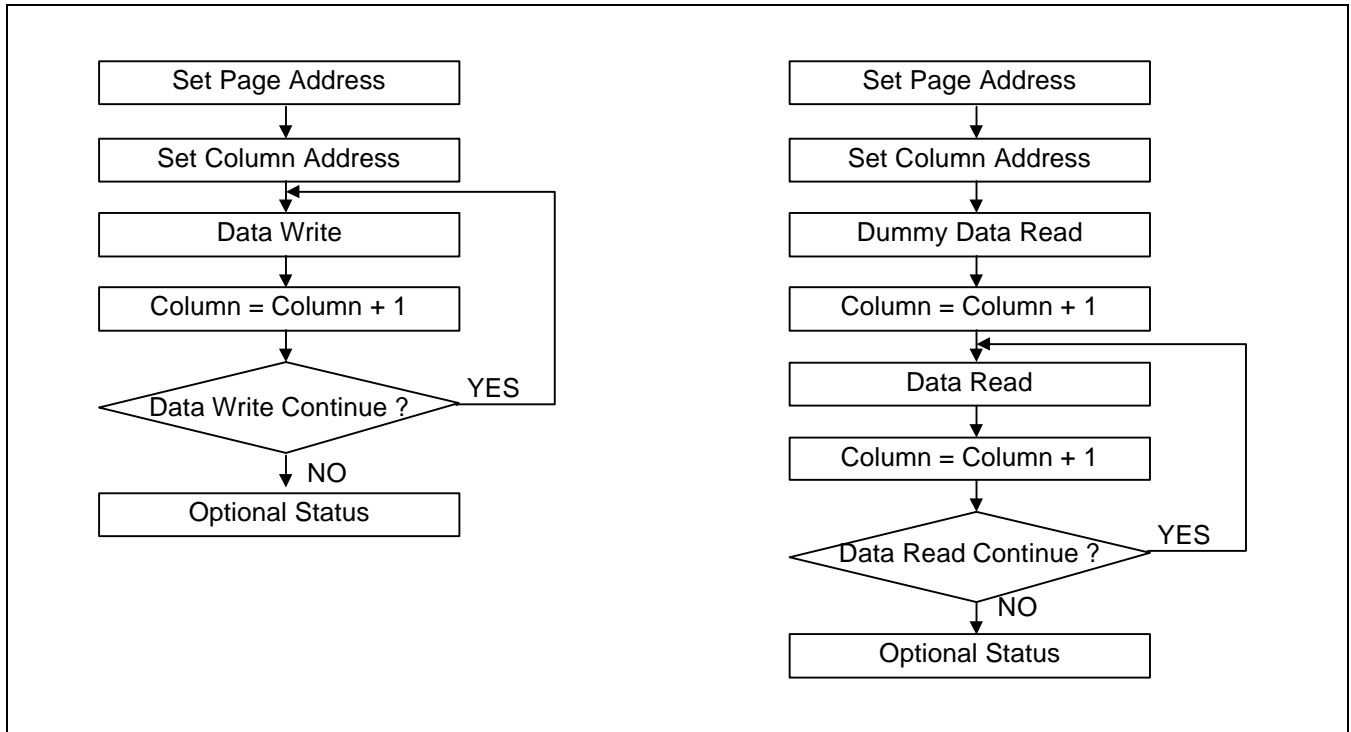

Figure 19. Sequence for Writing Display Data

Figure 20. Sequence for Reading Display Data

Read Status

Indicates the internal status of the KS0715

RS	RW	DB7	DB6	DB5	DB4	DB3	DB2	DB1	DB0
0	1	BUSY	ADC	ON/OFF	RESETB	0	0	0	0

Flag	Description
BUSY	The device is busy when internal operation or reset Any instruction is rejected until BUSY goes Low. 0: chip is active, 1: chip is being busy.
ADC	Indicates the relationship between RAM column address and segment driver. 0: reverse direction (SEG99 → SEG0), 1: normal direction (SEG0 → SEG99)
ON / OFF	Indicates display ON / OFF status 0: display ON, 1: display OFF
RESETB	Indicates the initialization is in progress by RESETB signal 0: chip is active, 1: chip is being reset

Display ON / OFF

Turns the display ON or OFF

RS	RW	DB7	DB6	DB5	DB4	DB3	DB2	DB1	DB0
0	0	1	0	1	0	1	1	1	DON

DON = 1: display ON

DON = 0: display OFF

Initial Display Line

Sets the line address of display RAM to determine the Initial Display Line. The RAM display data is displayed at the top row (COM0 when SHL = L, COM31 when SHL = H) of LCD panel.

RS	RW	DB7	DB6	DB5	DB4	DB3	DB2	DB1	DB0
0	0	0	1	ST5	ST4	ST3	ST2	ST1	ST0

ST5	ST4	ST3	ST2	ST1	ST0	Line address
0	0	0	0	0	0	0
0	0	0	0	0	1	1
:	:	:	:	:	:	:
1	1	1	1	1	0	62
1	1	1	1	1	1	63

Reference Voltage Select

Consists of 2-byte Instruction

The 1st instruction sets reference voltage mode, the 2nd one updates the contents of reference voltage register. After second instruction, reference voltage mode is released.

The 1st Instruction: Set Reference Voltage Select Mode

RS	RW	DB7	DB6	DB5	DB4	DB3	DB2	DB1	DB0
0	0	1	0	0	0	0	0	0	1

The 2nd Instruction: Set Reference Voltage Register

RS	RW	DB7	DB6	DB5	DB4	DB3	DB2	DB1	DB0
0	0	1	0	0	SV4	SV3	SV2	SV1	SV0

SV4	SV3	SV2	SV1	SV0	Reference voltage parameter (α)
0	0	0	0	0	0
0	0	0	0	1	1
:	:	:	:	:	:
:	:	:	:	:	:
1	1	1	1	0	30
1	1	1	1	1	31

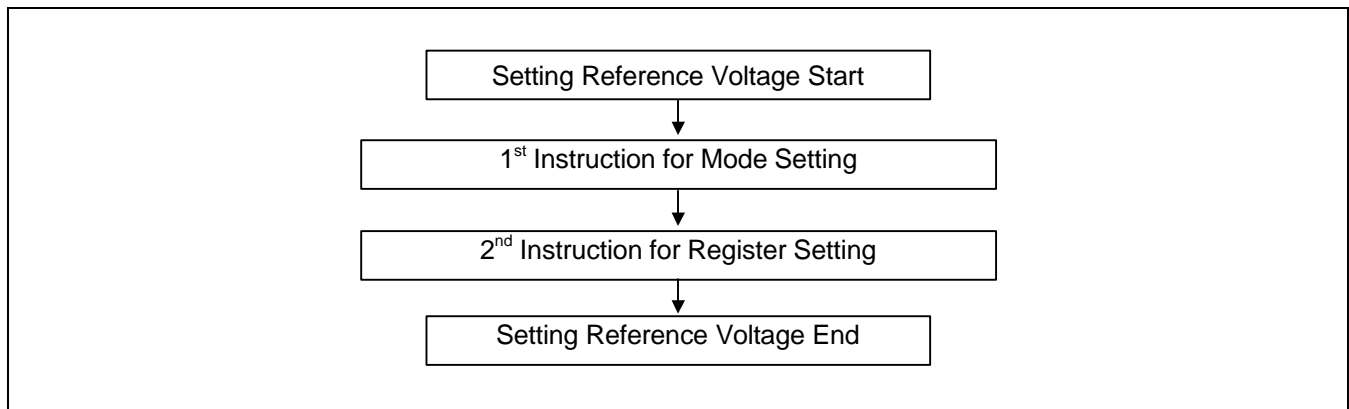

Figure 21. Sequence for Setting the Reference Voltage

Set Page Address

Sets the Page Address of display data RAM from the microprocessor into the Page Address register. Any RAM data bit can be accessed when its Page Address and column address are specified. Along with the column address, the Page Address defines the address of the display RAM to write or read display data. Changing the Page Address doesn't effect to the display status.

RS	RW	DB7	DB6	DB5	DB4	DB3	DB2	DB1	DB0
0	0	1	0	1	1	P3	P2	P1	P0

P3	P2	P1	P0	Page
0	0	0	0	0
0	0	0	1	1
:	:	:	:	:
0	1	1	1	7
1	0	0	0	8

Set Column Address

Sets the Column Address of display RAM from the microprocessor into the column address register. Along with the Column Address, the Column Address defines the address of the display RAM to write or read display data. When the microprocessor reads or writes display data to or from display RAM, Column Addresses are automatically increased.

Set Column Address MSB

RS	RW	DB7	DB6	DB5	DB4	DB3	DB2	DB1	DB0
0	0	0	0	0	1	0	Y6	Y5	Y4

Set Column Address LSB

RS	RW	DB7	DB6	DB5	DB4	DB3	DB2	DB1	DB0
0	0	0	0	0	0	Y3	Y2	Y1	Y0

Y6	Y5	Y4	Y3	Y2	Y1	Y0	Column address
0	0	0	0	0	0	0	0
0	0	0	0	0	0	1	1
:	:	:	:	:	:	:	:
1	1	0	0	0	1	0	98
1	1	0	0	0	1	1	99

ADC Select

Changes the relationship between RAM column address and segment driver. The direction of segment driver output pins could be reversed by software. This makes IC layout flexible in LCD module assembly.

RS	RW	DB7	DB6	DB5	DB4	DB3	DB2	DB1	DB0
0	0	1	0	1	0	0	0	0	ADC

ADC = 0: normal direction (SEG0 → SEG99)

ADC = 1: reverse direction (SEG99 → SEG0)

Reverse Display ON / OFF

Reverses the display status on LCD panel without rewriting the contents of the display data RAM.

RS	RW	DB7	DB6	DB5	DB4	DB3	DB2	DB1	DB0
0	0	1	0	1	0	0	1	1	REV

REV	RAM bit data = "1"	RAM bit data = "0"
0 (normal)	LCD pixel is illuminated	LCD pixel is not illuminated
1 (reverse)	LCD pixel is not illuminated	LCD pixel is illuminated

Reverse Display ON / OFF

Forces the whole LCD points to be turned on regardless of the contents of the display data RAM. At this time, the contents of the display data RAM are held. This instruction has priority over the reverse display ON / OFF instruction.

RS	RW	DB7	DB6	DB5	DB4	DB3	DB2	DB1	DB0
0	0	1	0	1	0	0	1	0	EON

EON = 0: normal display

EON = 1: entire display ON

Select LCD Bias

Selects LCD bias ratio of the voltage required for driving the LCD.

RS	RW	DB7	DB6	DB5	DB4	DB3	DB2	DB1	DB0
0	0	1	0	1	0	0	0	1	Bias

Duty ratio	LCD bias	
	Bias = 0	Bias = 1
1/33	1/6	1/5

Set Modify-read

This instruction stops the automatic increment of the column address by the read display data instruction, but the column address is still increased by the write display data instruction. And it reduces the load of microprocessor when the data of a specific area is repeatedly changed during cursor blinking or others. This mode is canceled by the reset Modify-read instruction.

RS	RW	DB7	DB6	DB5	DB4	DB3	DB2	DB1	DB0
0	0	1	1	1	0	0	0	0	0

Reset Modify-read

This instruction cancels the Modify-read mode, and makes the column address return to its initial value just before the set Modify-read instruction is started.

RS	RW	DB7	DB6	DB5	DB4	DB3	DB2	DB1	DB0
0	0	1	1	1	0	1	1	1	0

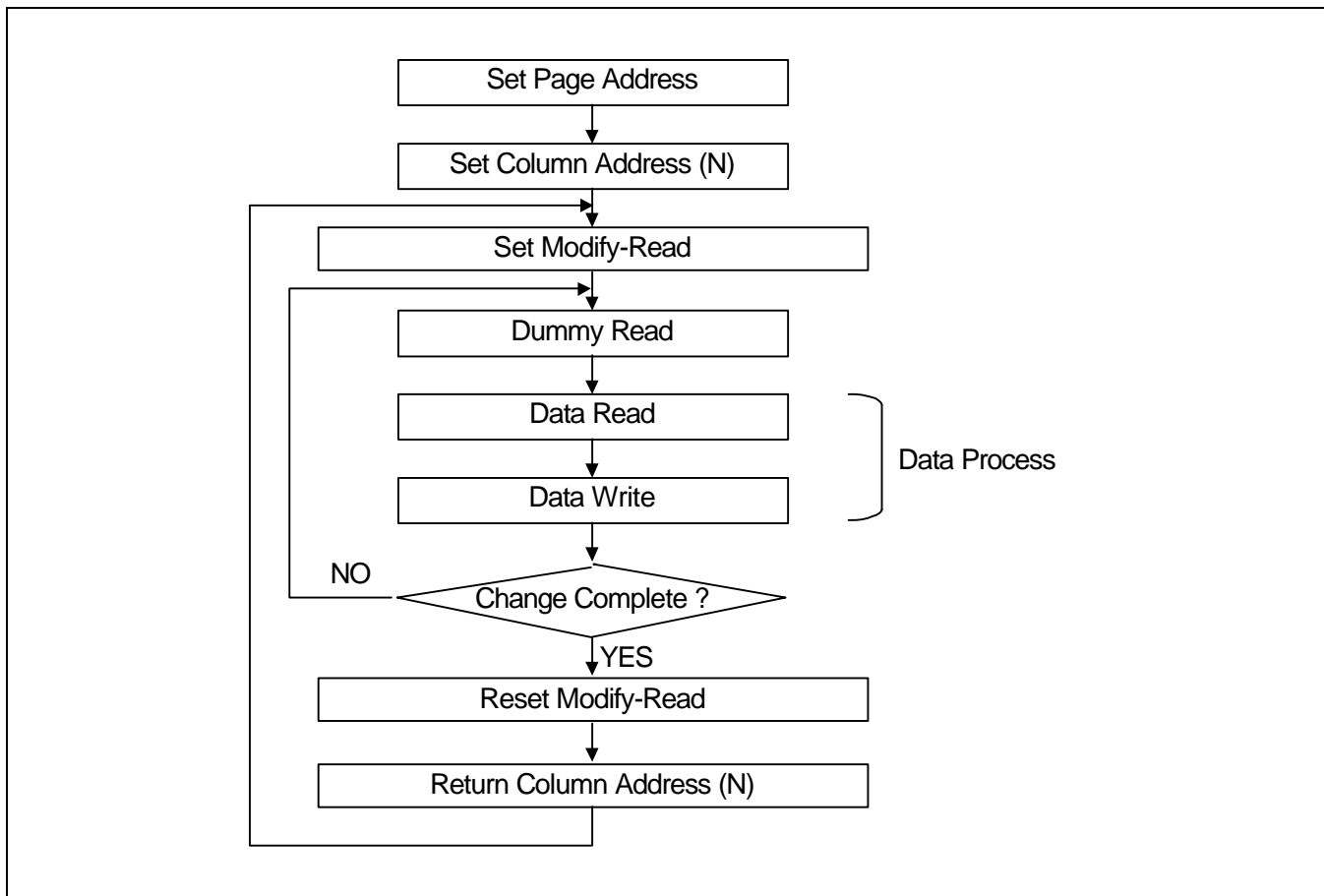

Figure 22. Sequence for Cursor Display

Reset

This instruction Resets initial display line, column address, page address, and common output status select to their initial status, but does not affect the contents of display data RAM. This instruction cannot initialize the LCD power supply, which is initialized by the RESETB pin.

RS	RW	DB7	DB6	DB5	DB4	DB3	DB2	DB1	DB0
0	0	1	1	1	0	0	0	1	0

SHL Select

COM output scanning direction is selected by this instruction which determines the LCD driver output status.

RS	RW	DB7	DB6	DB5	DB4	DB3	DB2	DB1	DB0
0	0	1	1	0	0	SHL	×	×	×

× : Don't care

SHL = 0: normal direction (COM0 → COM31)

SHL = 1: reverse direction (COM31 → COM0)

Power Control

Selects one of eight power circuit functions by using 3-bit register. An external power supply and part of internal power supply functions can be used simultaneously.

RS	RW	DB7	DB6	DB5	DB4	DB3	DB2	DB1	DB0
0	0	0	0	1	0	1	VC	VR	VF

VC	VR	VF	Status of internal power supply circuits
0			Internal voltage converter circuit is OFF
1			Internal voltage converter circuit is ON
	0		Internal voltage regulator circuit is OFF
	1		Internal voltage regulator circuit is ON
		0	Internal voltage follower circuit is OFF
		1	Internal voltage follower circuit is ON

Set Static Indicator State

This instruction sets the Static Indicator ON / OFF. When it is on, the static indicator operates and blinks at an interval of approximately 1 second.

Set Static Indicator Register

RS	RW	DB7	DB6	DB5	DB4	DB3	DB2	DB1	DB0
0	0	1	0	1	0	1	1	0	SI

SI	Status of static indicator output
0	OFF
1	ON (about 1 second blinking)

Power Save (Compound Instruction)

If the entire display ON / OFF instruction is issued during the display OFF state, KS0715 enters the Power Save status to reduce the power consumption to the static power consumption value. According to the status of static indicator mode, Power Save is entered to one of two modes (sleep and standby mode). When static indicator mode is ON, standby mode is issued, when OFF, sleep mode is issued. Power Save mode is released by the display ON & entire display OFF instruction.

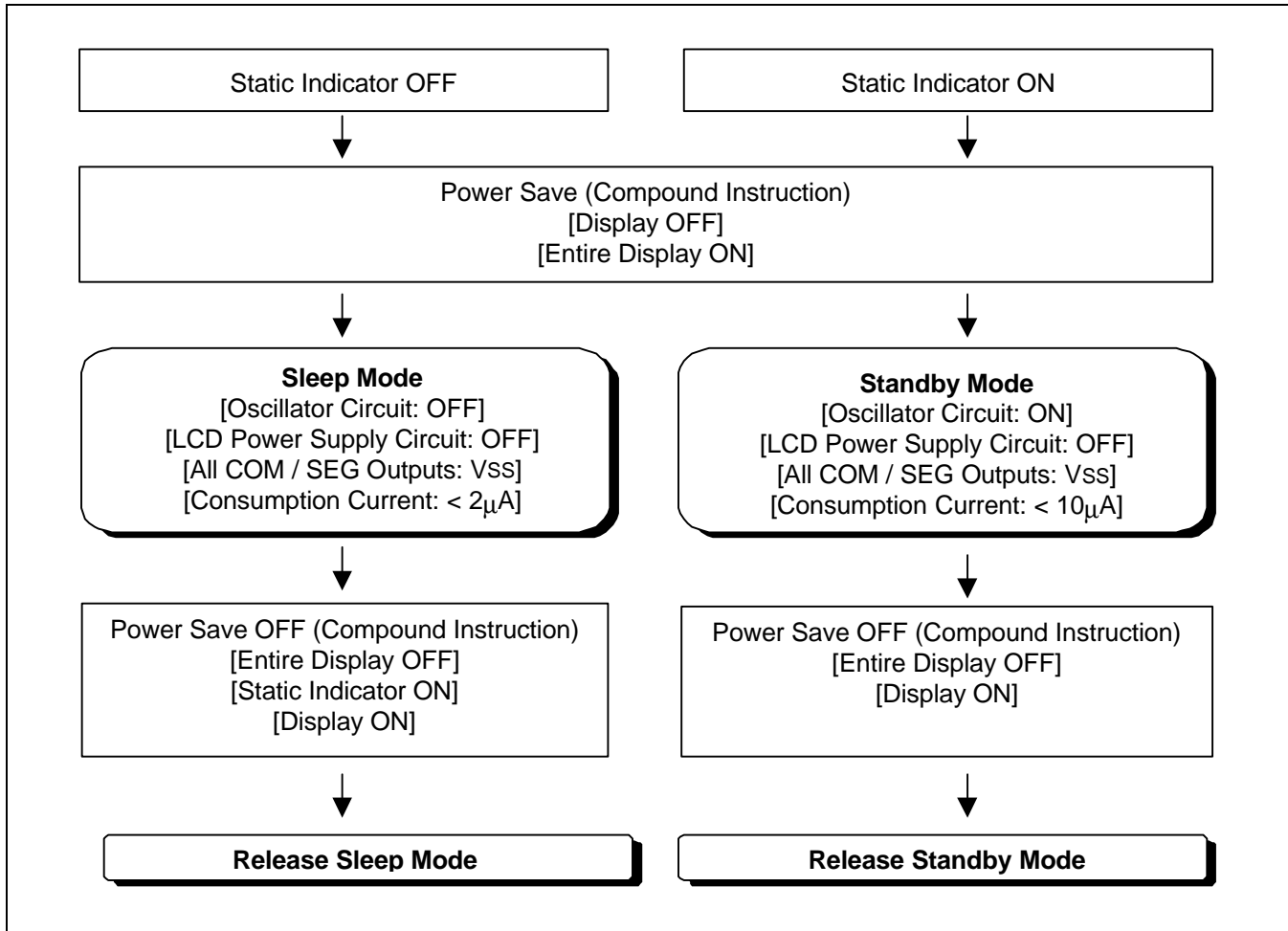

Figure 23. Power Save Routine

Referential Instruction Setup Flow (1)

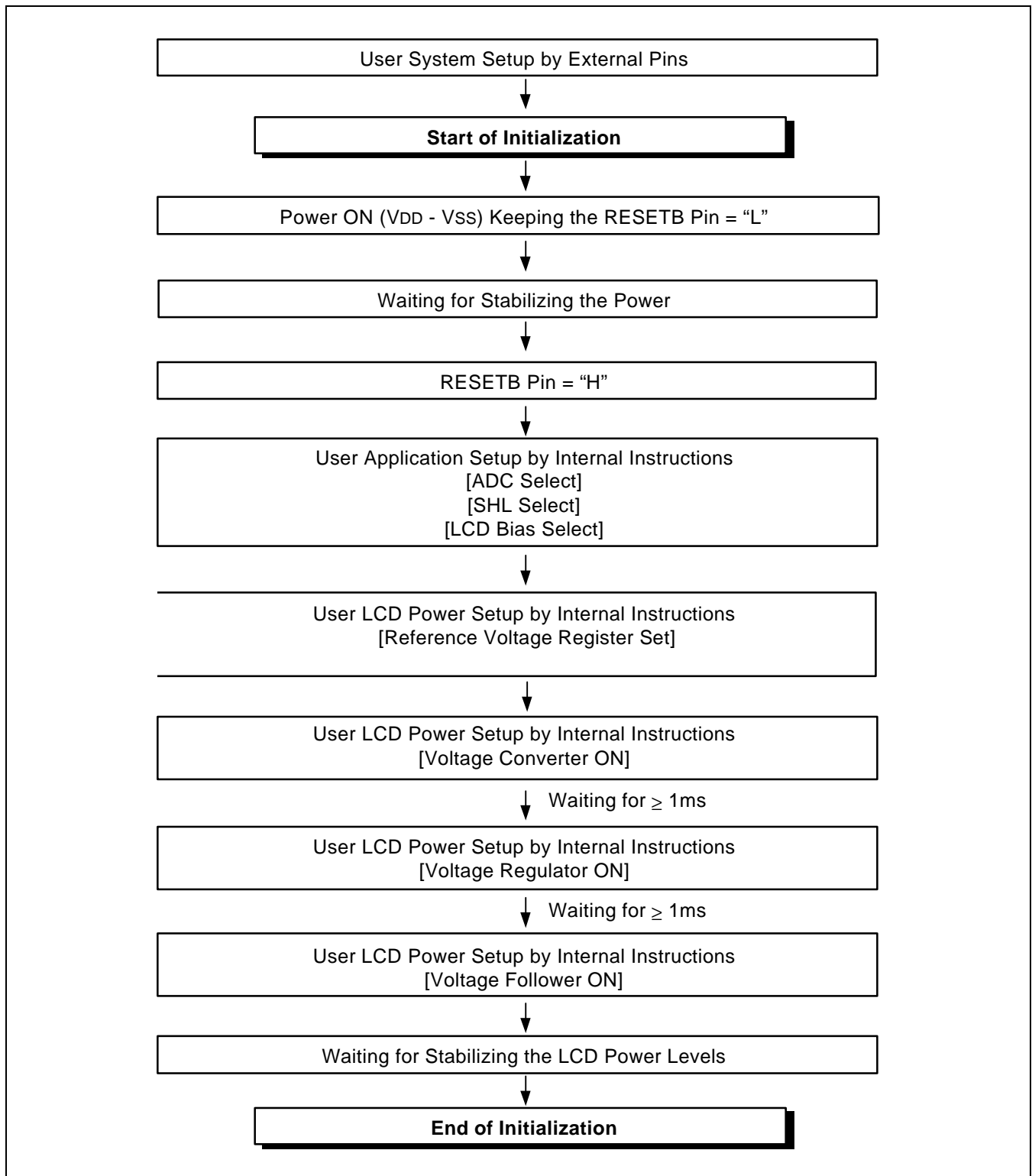

Figure 24. Initializing with the Built-in Power Supply Circuits

Referential Instruction Setup Flow (2)

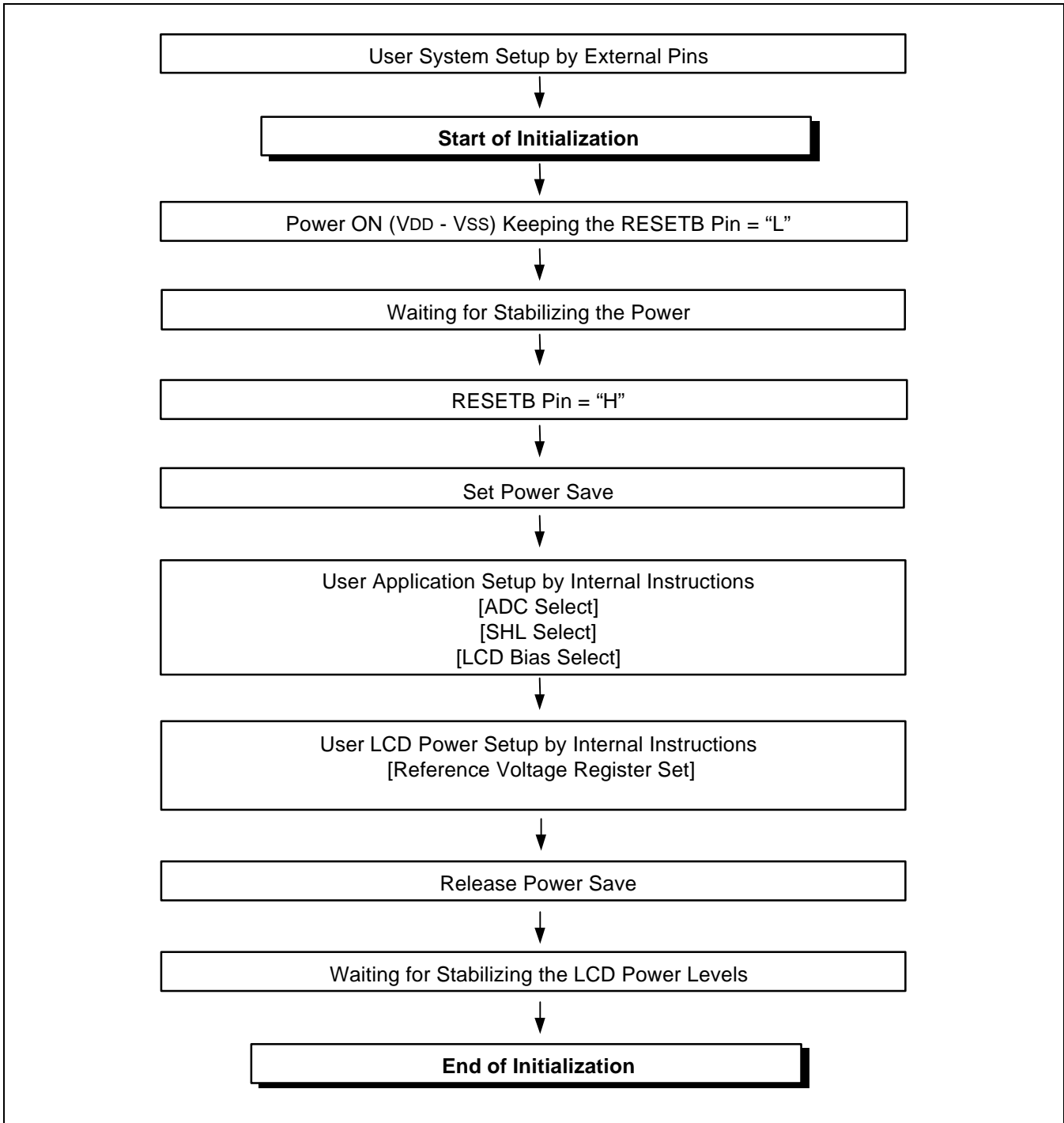

Figure 25. Initializing without the Built-in Power Supply Circuits

Referential Instruction Setup Flow (3)

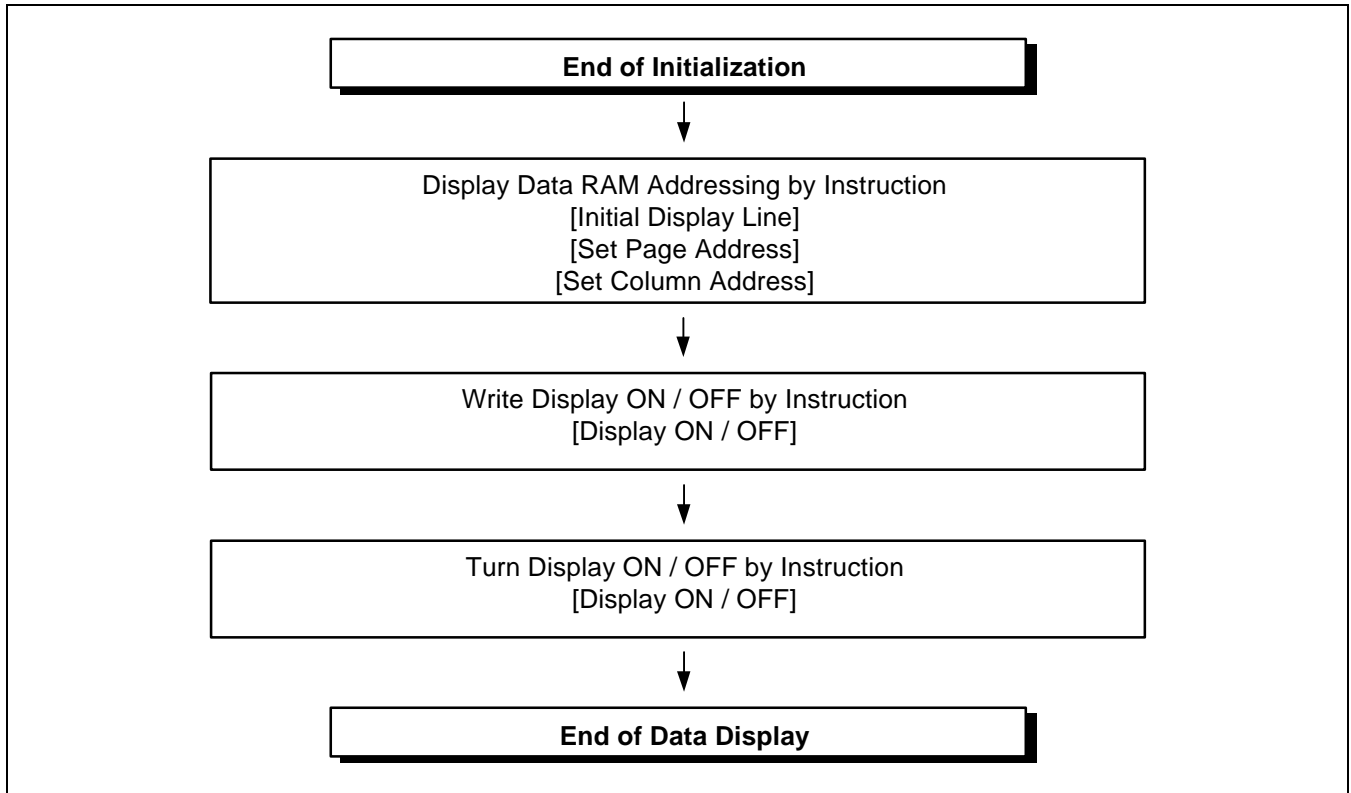

Figure 26. Data Displaying

Referential Instruction Setup Flow (4)

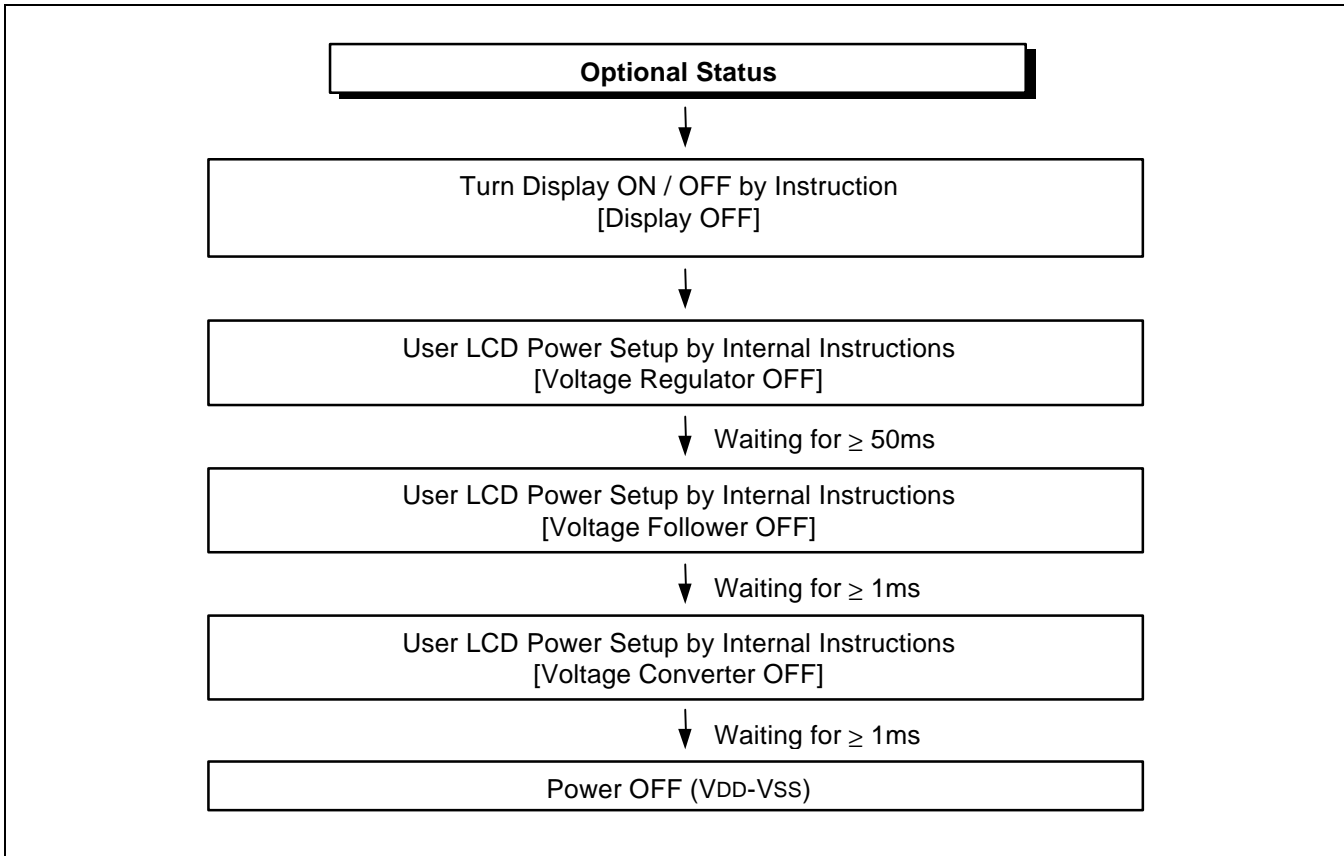

Figure 27. Power OFF

SPECIFICATIONS

ABSOLUTE MAXIMUM RATINGS

Table 19. Absolute Maximum Ratings

Parameter	Symbol	Rating	Unit
Supply voltage range	V _{DD}	- 0.3 to +7.0	V
	V _{LCD}	- 0.3 to +17.0	V
Input voltage range	V _{IN}	- 0.3 to V _{DD} +0.3	V
Operating temperature range	T _{OPR}	- 40 to +85	°C
Storage temperature range	T _{STR}	- 55 to +125	°C

NOTES:

1. V_{DD} and V_{LCD} are based on V_{SS} = 0V.
2. Voltages V₀ ≥ V₁ ≥ V₂ ≥ V₃ ≥ V₄ ≥ V_{SS} must always be satisfied. (V_{LCD} = V₀ – V_{SS})
3. If supply voltage exceeds its absolute maximum range, this LSI may be damaged permanently.
It is desirable to use this LSI under electrical characteristic conditions during general operation.
Otherwise, this LSI may malfunction or reduced LSI reliability may result.

DC CHARACTERISTICS

Table 20. DC Characteristics

($V_{SS} = 0V$, $V_{DD} = 2.4$ to $3.6V$, $T_a = -40$ to $85^{\circ}C$)

Item	Symbol	Condition	Min.	Typ.	Max.	Unit	Pin used	
Operating voltage (1)	VDD		2.4	-	3.6	V	VDD *1	
Operating voltage (2)	V0		4.0	-	15.0	V	V0 *2	
Input voltage	High	V _{IH}	0.8V _{DD}	-	V _{DD}	V	*3	
	Low	V _{IL}	V _{SS}	-	0.2V _{DD}			
Output voltage	High	V _{OH}	I _{OH} = -0.5mA	0.8V _{DD}	-	V _{DD}	*4	
	Low	V _{OL}	I _{OL} = 0.5mA	V _{SS}	-	0.2V _{DD}		
Input leakage current	I _{IL}	V _{IN} = V _{DD} or V _{SS}	- 1.0	-	+ 1.0	μA	*5	
Output leakage current	I _{OZ}	V _{IN} = V _{DD} or V _{SS}	- 3.0	-	+ 3.0	μA	*6	
LCD driver ON resistance	R _{ON}	T _a = 25°C, V ₀ = 8V	-	2.0	3.0	kΩ	SE _{Gn} COM _n *7	
Oscillator frequency (1)	Internal	f _{OSC}	T _a = 25°C	17	22.5	27	kHz	CL *8
	External	f _{CL}		2.13	2.81	3.37		
Voltage converter input voltage	V _{DD}	× 2	2.4	-	3.6	V	V _{DD}	
		× 3	2.4	-	3.6			
		× 4	2.4	-	3.6			
Voltage converter output voltage	V _{OUT}	×2 / ×3 / ×4 voltage conversion (no-load)	95	99	-	%	V _{OUT}	
Voltage regulator operating voltage	V _{OUT}		4.0	-	15.0	V	V _{OUT}	
Voltage follower operating voltage	V ₀		4.0	-	15.0	V	V ₀ *9	
Reference voltage	V _{REF0}	T _a = 25°C	-0.05%/°C	1.84	1.9	1.96	V	*10
	V _{REF1}		-0.2%/°C	2.04	2.1	2.16	V	*10

Dynamic Current Consumption (1): when the Built-in Power Circuit is OFF (At Operate Mode)

(Ta = 25°C)

Item	Symbol	Condition	Min.	Typ.	Max.	Unit	Pin used
Dynamic current consumption (1)	IDD1	V _{DD} = 3.0V V _O – V _{SS} = 8.0V Display OFF, checker pattern	-	5	20	μA	*11

Dynamic Current Consumption (2): when the built-in power circuit is ON (At operate mode)

(Ta = 25°C)

Item	Symbol	Condition	Min.	Typ.	Max.	Unit	Pin used
Dynamic current consumption (2)	IDD2	V _{DD} = 3.0V, quad boosting, V _O – V _{SS} = 8.0V, 1/65 duty ratio, Display OFF, checker pattern Normal power mode	-	47	70	μA	*12
		V _{DD} = 3.0V, quad boosting, V _O – V _{SS} = 8.0V, Display ON, checker pattern Normal power mode	-	75	100		

Current Consumption during Power Save mode

(Ta = 25°C)

Item	Symbol	Condition	Min.	Typ.	Max.	Unit	Pin used
Sleep mode	IDDS1	During sleep	-	-	2.0	μA	
Standby mode	IDDS2	During standby	-	-	10.0	μA	

Table 21. The relationship between oscillation frequency and frame frequency

Duty ratio	Item	fCL	fM
1/33	On-chip oscillator circuit is used	$\frac{f_{osc}}{8}$	$\frac{f_{osc}}{16 \times 33}$
	On-chip oscillator circuit is not used	External input (fCL)	$\frac{f_{osc}}{2 \times 33}$

(fosc: oscillation frequency, fCL: display clock frequency, fM: LCD AC signal frequency)

[* Remark Solves]

- *1. Though the wide range of operating voltages is guaranteed, a spike voltage change may affect the voltage assurance during access from the MPU.
- *2. In case of external power supply is applied.
- *3. CS1B, CS2, RS, DB0 to DB7, E_RD, RW_WR, RESETB, MS, MI, PS, TEMPS, CL, M, DISP pins.
- *4. DB0 to DB7, M, FRS, DISP, CL pins.
- *5. CS1B, CS2, RS, DB[7:0], E_RD, RW_WR, RESETB, MS, MI, PS, TEMPS, CL, M, DISP pins.
- *6. Applies when the DB[7:0], M, DISP, and CL pins are in high impedance.
- *7. Resistance value when ± 0.1 [mA] is applied during the ON status of the output pin SEGn or COMn.
RON= $\Delta V / 0.1$ [k Ω] (ΔV : voltage change when ± 0.1 [mA] is applied in the ON status.)
- *8. See table 21 for the relationship between oscillation frequency and frame frequency.
- *9. The voltage regulator circuit adjusts V0 within the voltage follower operating voltage range.
- *10. On-chip reference voltage source of the voltage regulator circuit to adjust V0.
- *11,12. Applies to the case where the on-chip oscillation circuit is used and no access is made from the MPU.
The current consumption, when the built-in power supply circuit is ON or OFF.
The current flowing through voltage regulation resistors (Ra and Rb) is not included.
It does not include the current of the LCD panel capacity, wiring capacity, etc.

REFERENCE DATA

IDD1 vs. VDD

- Test Condition: Temperature (25°C & 85°C), V0 = 8V (External), TEMPS = 'L', 1/33 Duty, Ra = 1 [MΩ], Rb = 3 [MΩ], Normal Power Mode

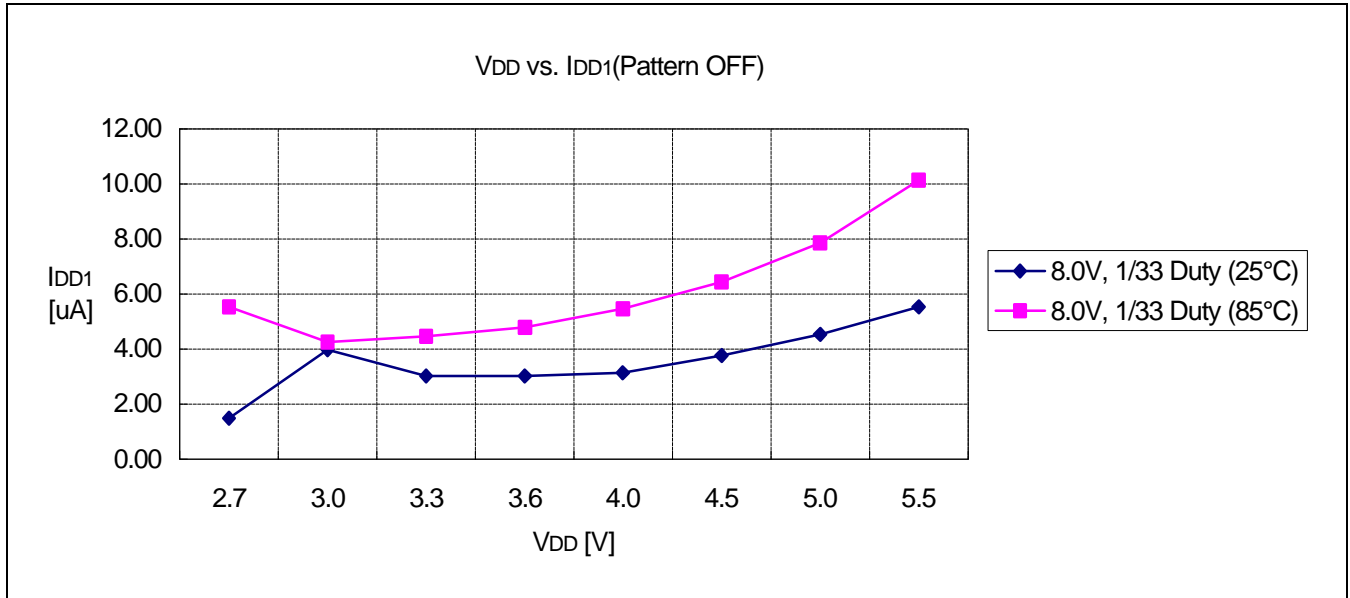

Figure 28. Display Pattern is OFF

IDD2 vs. VDD

- Test Condition: Temperature (25°C & 85°C), Quad boosting, RR = 6, EV = 32, TEMPS = 'L', 1/33 duty, Ra = 1 [MΩ], Rb = 3 [MΩ], Normal Power Mode

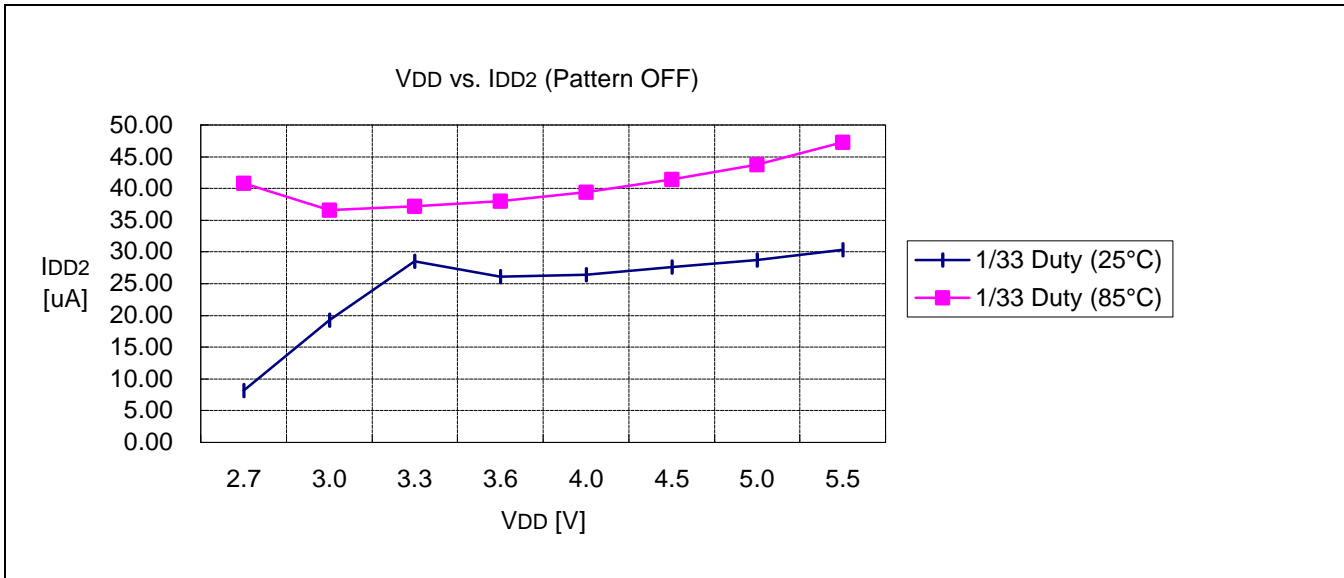

Figure 29. Display Pattern is OFF

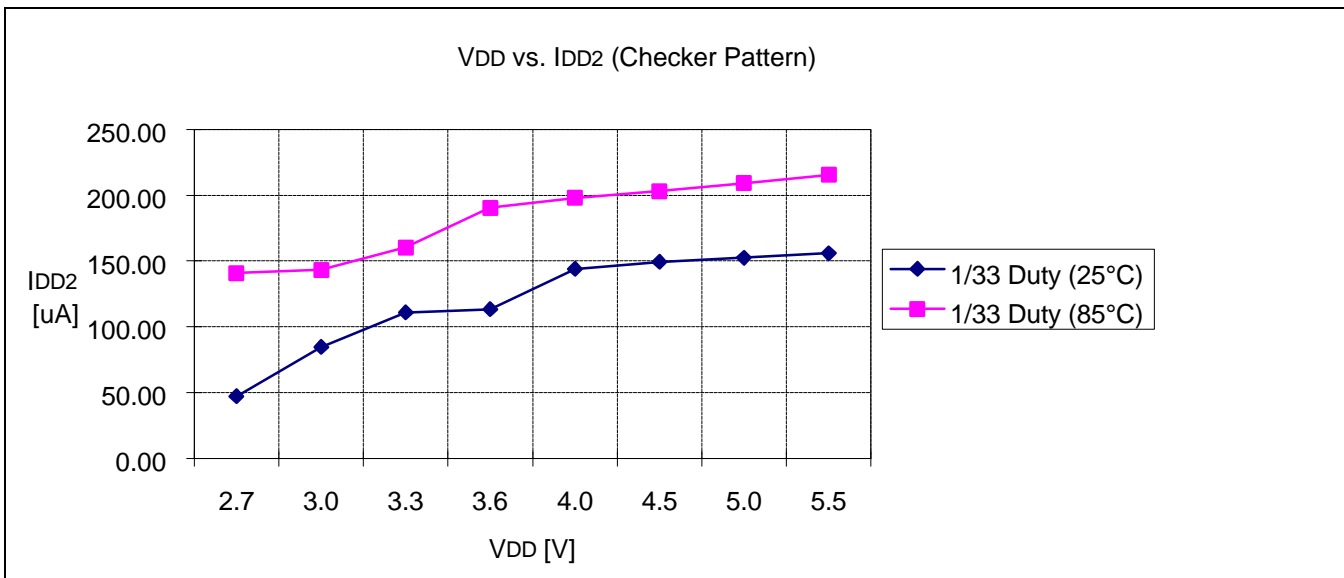

Figure 30. Display Pattern is Checker

AC CHARACTERISTICS

Read / Write Characteristics (8080-series MPU)

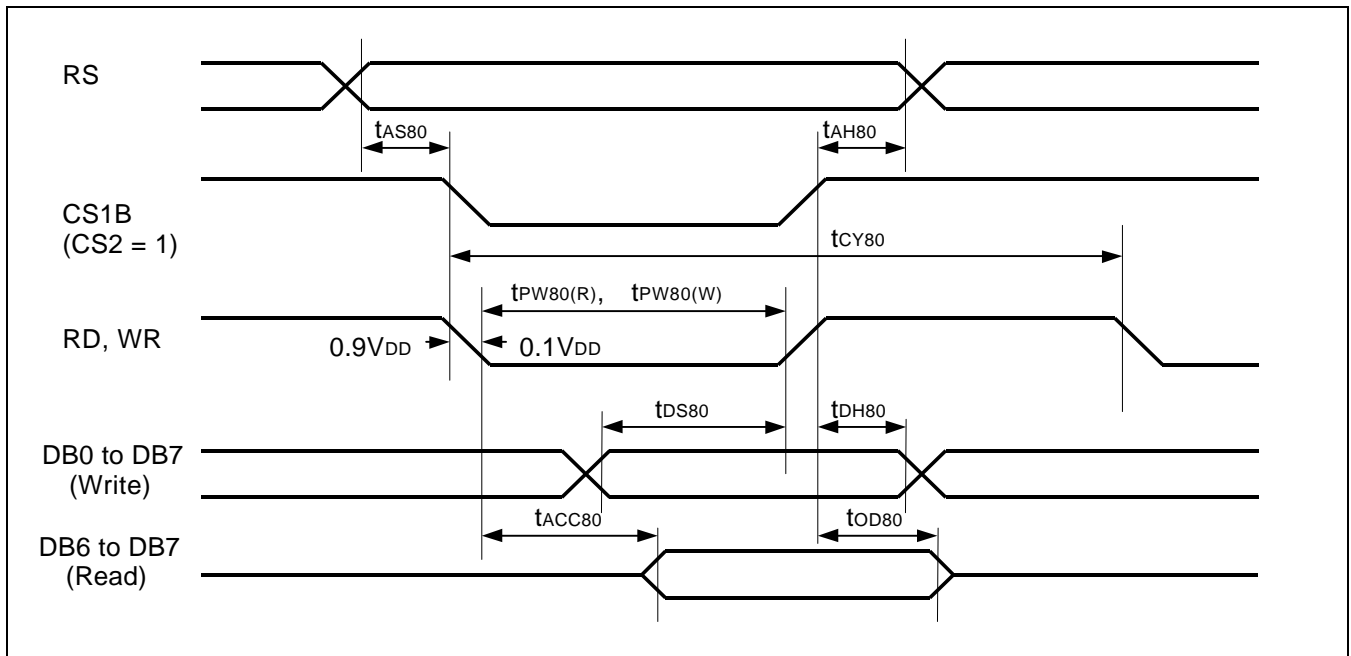

Figure 31. Read / Write Characteristics (8080-series MPU)

(VDD = 2.4 to 3.6V, Ta = -40 to +85°C)

Item	Signal	Symbol	Min.	Typ.	Max.	Unit	Remark
Address setup time	RS	tAS80	13	-	-	ns	
Address hold time	RS	tAH80	17	-	-	ns	
System cycle time	RS	tCY80	400	-	-	ns	
Pulse width (WR)	RW_WR	tPW80(W)	55	-	-	ns	
Pulse width (RD)	E_RD	tPW80(R)	125	-	-	ns	
Data setup time	DB7 to DB0	tDS80	35	-	-	ns	
Data hold time		tDH80	13	-	-	ns	
Read access time	DB0	tACC80	-	-	125	ns	CL = 100 pF
Output disable time		tOD80	10	-	90	ns	

Read / Write Characteristics (6800-series Microprocessor)

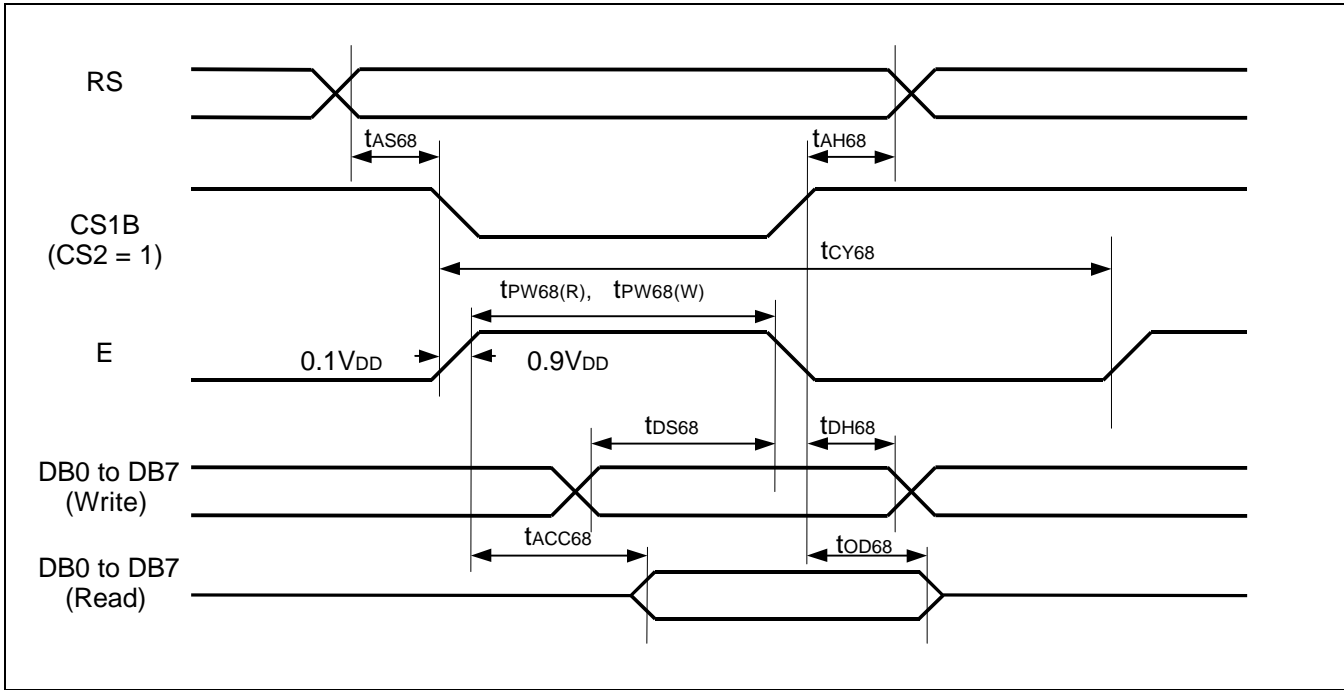

Figure 32. Read / Write Characteristics (6800-series Microprocessor)

(V_{DD} = 2.4 to 3.6V, T_a = -40 to +85°C)

Item	Signal	Symbol	Min.	Typ.	Max.	Unit	Remark
Address setup time	RS	tAS68	13	-	-	ns	
Address hold time	RS	tAH68	17	-	-	ns	
System cycle time	RS	tCY68	400	-	-	ns	
Data setup time	DB7 to DB0	tDS68	35	-	-	ns	
Data hold time		tDH68	13	-	-	ns	
Access time	DB7 to DB0	tACC68	-	-	125	ns	CL = 100 pF
Output disable time		tOD68	10	-	90		
Enable pulse width	Read	tPW68(R)	125	-	-	-	
	Write	tPW68(W)	55	-	-	-	

Serial Interface Characteristics

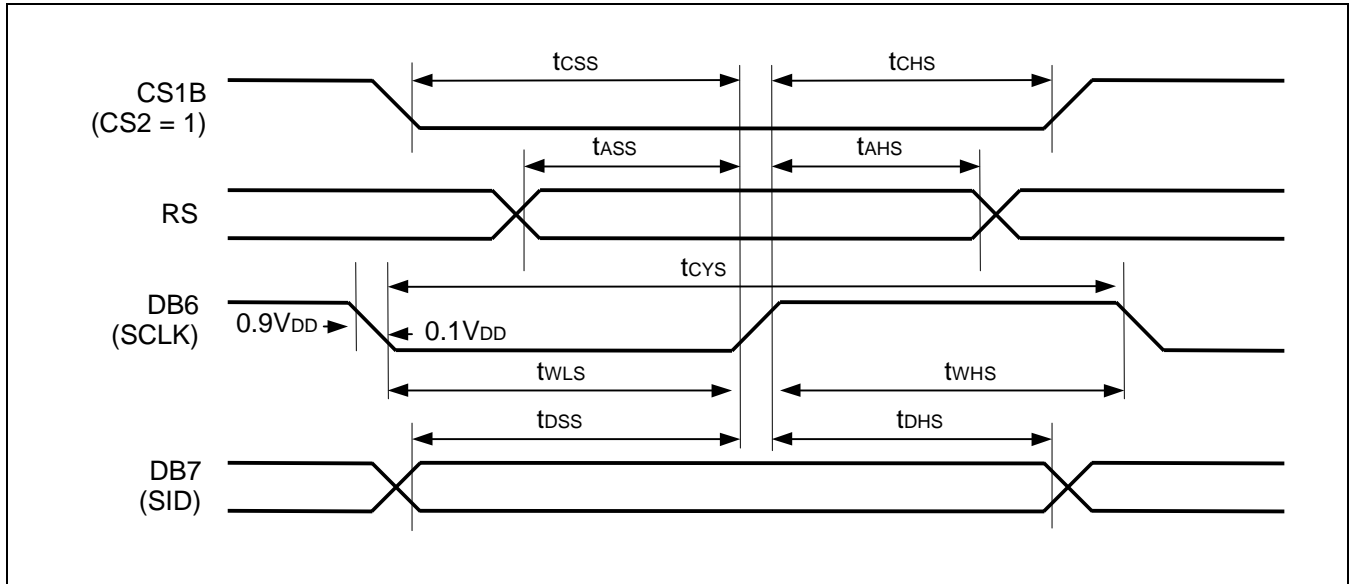

Figure 33. Serial Interface Characteristics

($V_{DD} = 2.4$ to $3.6V$, $T_a = -40$ to $+85^{\circ}C$)

Item	Signal	Symbol	Min	Typ	Max	Unit	Remark
Serial clock cycle	DB6 (SCLK)	tcYS	450	-	-	ns	
SCLK high pulse width		twHS	180	-	-		
SCLK low pulse width		twLS	135	-	-		
Address setup time	RS	tASS	90	-	-	ns	
Address hold time		tAHS	360	-	-		
Data setup time	DB7 (SID)	tdSS	90	-	-	ns	
Data hold time		tdHS	90	-	-		
CS1B setup time	CS1B	tcSS	55	-	-	ns	
CS1B hold time		tCHS	180	-	-		

Reset Input Timing

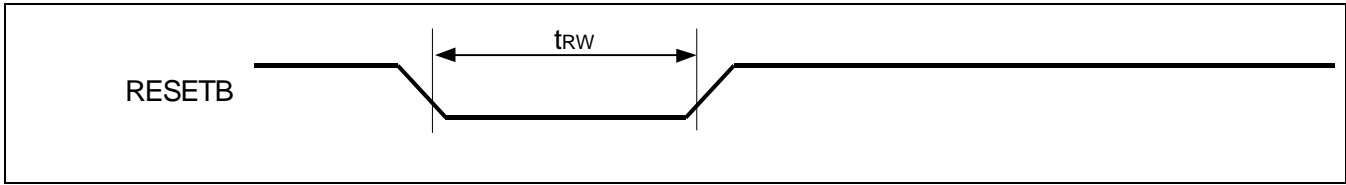

Figure 34. Reset Input Timing

(V_{DD} = 2.4 to 3.6V, T_a = -40 to +85°C)

Item	Signal	Symbol	Min.	Typ.	Max.	Unit	Remark
Reset low pulse width	RESETB	t _{rw}	900	-	-	ns	

Display Control Output Timing

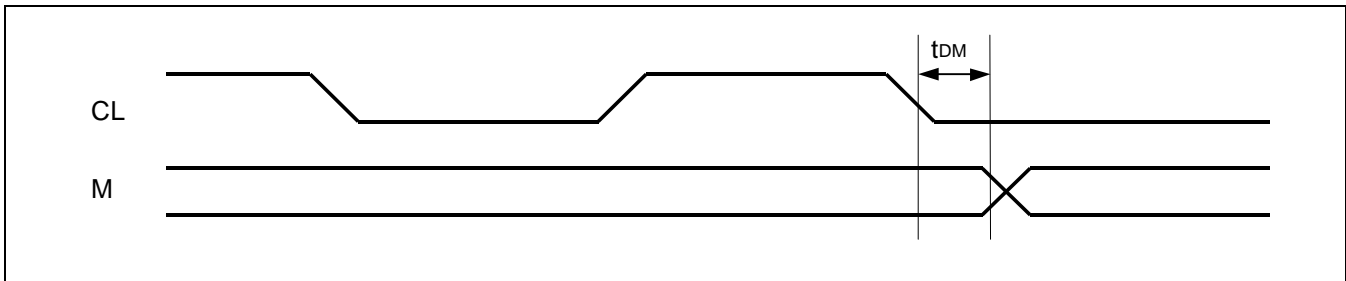

Figure 35. Display Control Output Timing

(V_{DD} = 2.4 to 3.6V, T_a = -40 to +85°C)

Item	Signal	Symbol	Min.	Typ.	Max.	Unit	Remark
M delay time	M	t _{DM}	-	13	70	ns	

REFERENCE APPLICATIONS

MICROPROCESSOR INTERFACE

In Case of Interfacing with 6800-series (PS = "H", MI = "H")

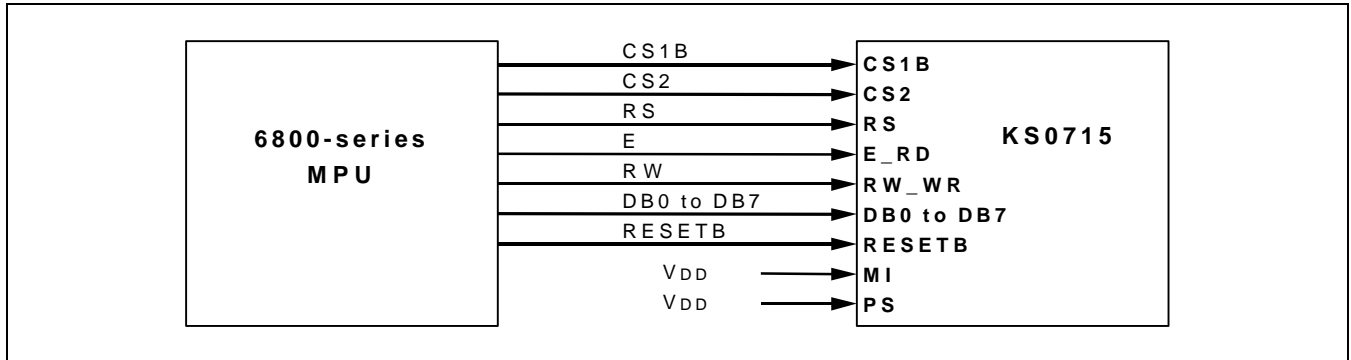

Figure 36. Interfacing with 6800-series (PS = "H", MI = "H")

In Case of Interfacing with 8080-series (PS = "H", MI = "L")

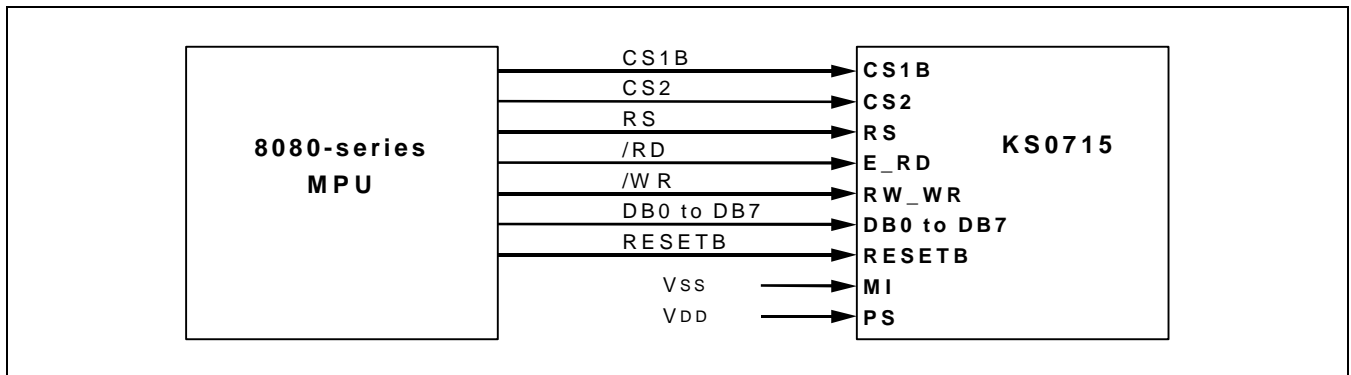

Figure 37. Interfacing with 8080-series (PS = "H", MI = "L")

In Case of Serial Interface (PS = "L", MI = "H/L")

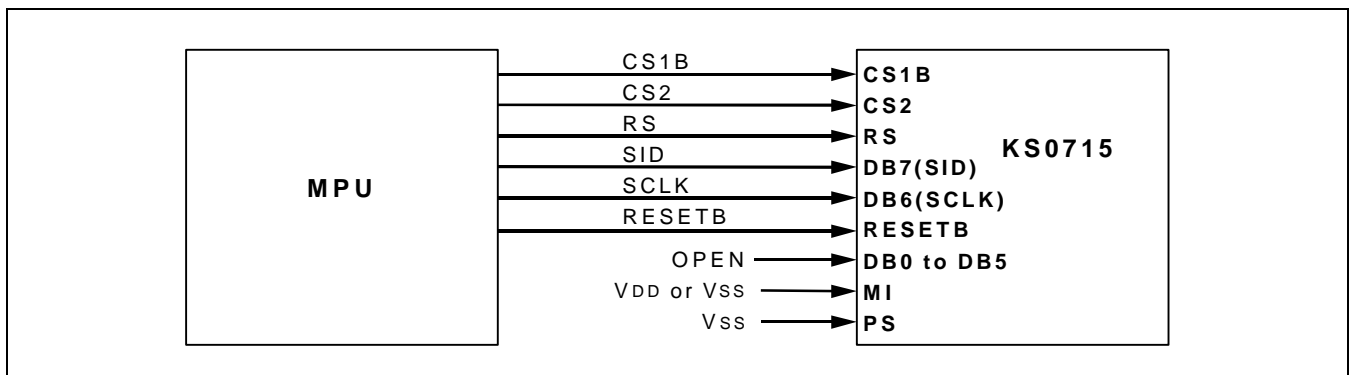

Figure 38. Serial interface (PS = "L", MI = "H/L")

CONNECTIONS BETWEEN KS0715 AND LCD PANEL

Single Chip Configuration (1/33 Duty Configurations)

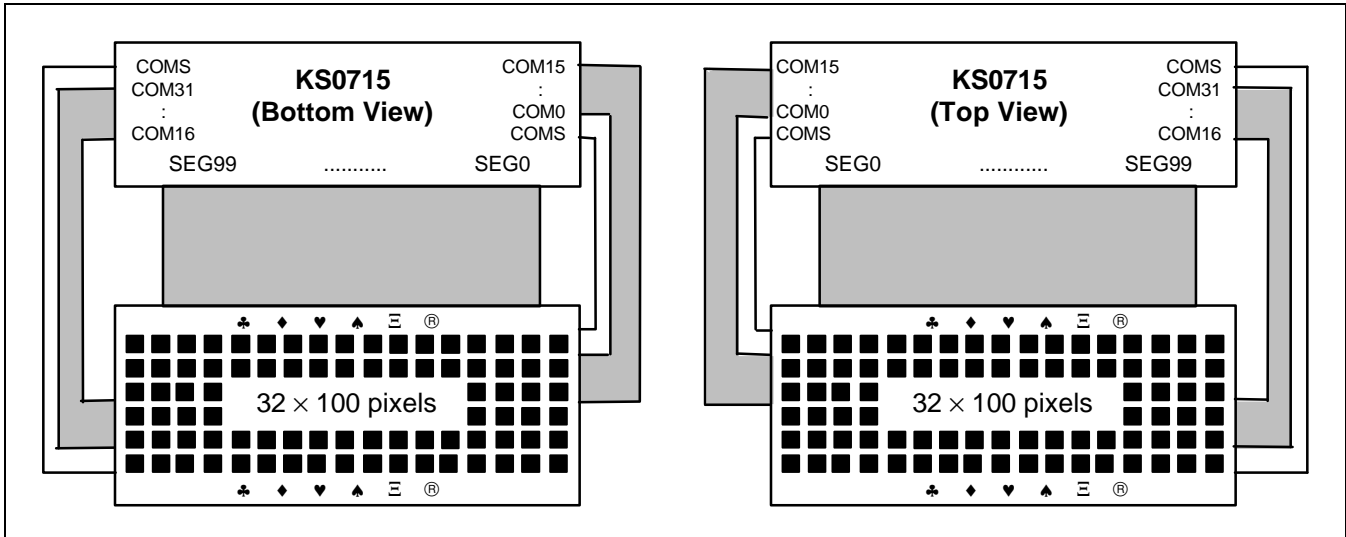

Figure 39. SHL = 0, ADC = 1

Figure 40. SHL = 0, ADC = 0

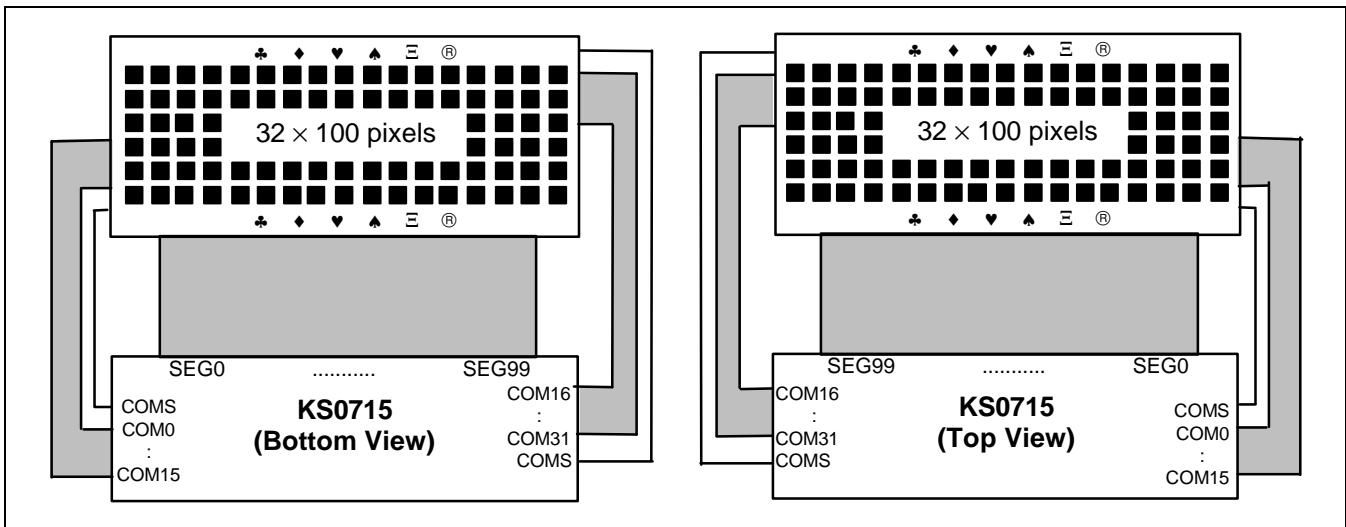

Figure 41. SHL = 1, ADC = 0

Figure 42. SHL = 1, ADC = 1

Multiple Chip Configuration

- 33COM (32COM + 1COMS) × 200SEG (100SEG × 2)

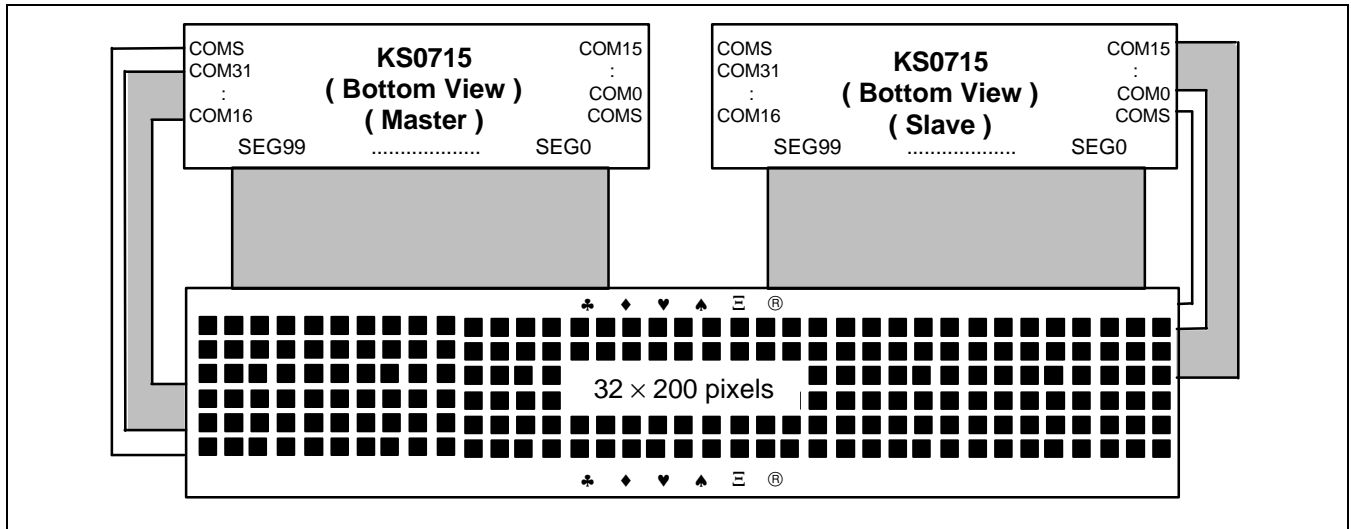

Figure 43. SHL = 0, ADC = 1

- ◆ Connect the following pins of two chips each other
 - Display clock pins: CL, M
 - Display control pin: DISP
 - LCD power pins: V0, V1, V2, V3, V4

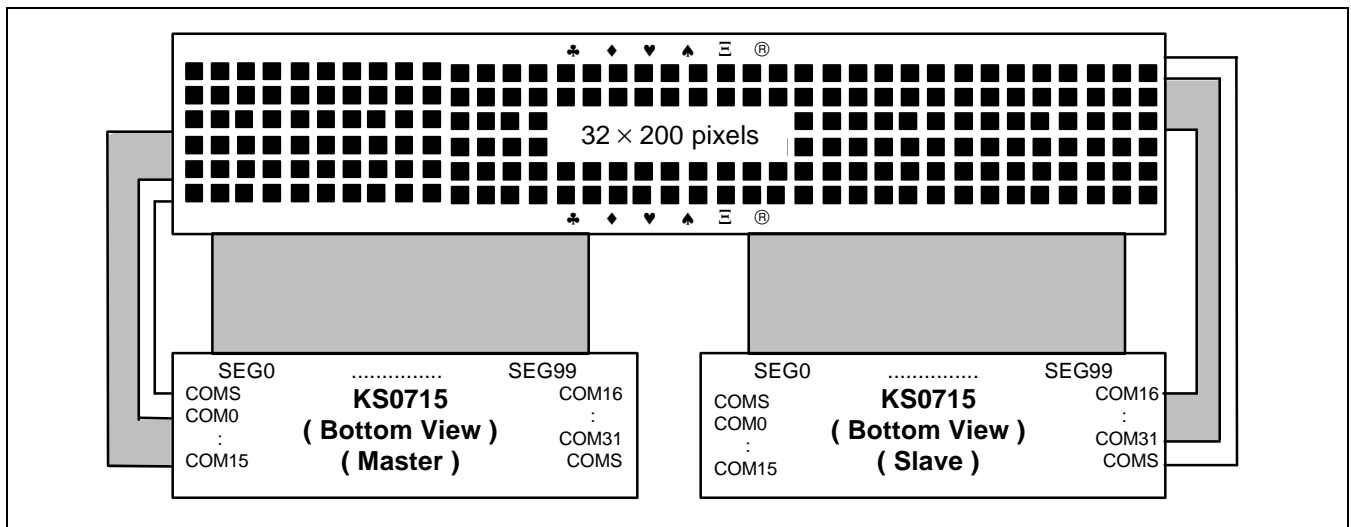

Figure 44. SHL = 1, ADC = 0

- ◆ Connect the following pins of two chips each other
 - Display clock pins: CL, M
 - Display control pin: DISP
 - LCD power pins: V0, V1, V2, V3, V4

- 66COM (64COM + 2COMS) × 100SEG

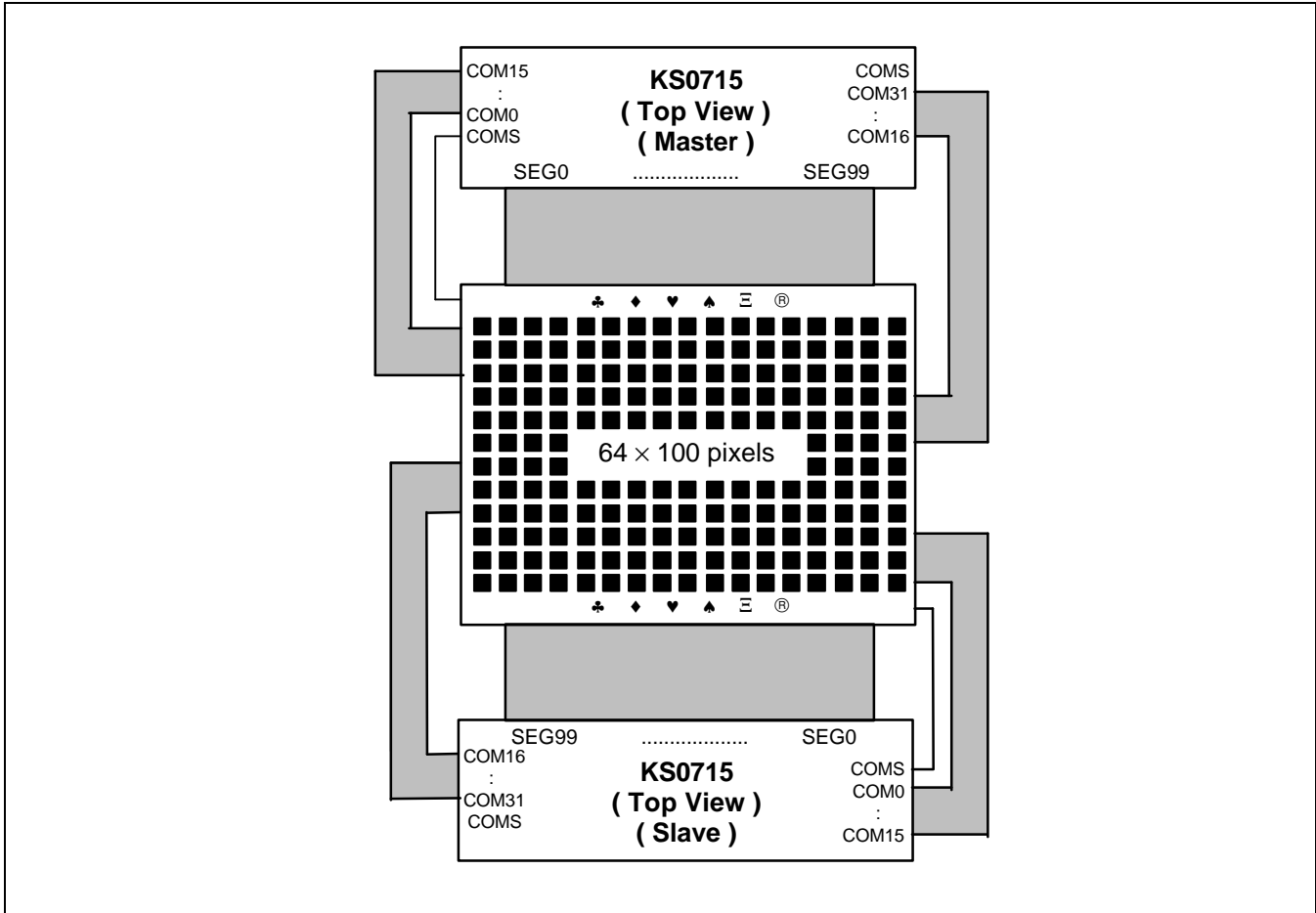

Figure 45. 66COM (64COM + 2COMS) × 100SEG

- ◆ Connect the following pins of two chips each other
 - Display clock pins: CL, M
 - Display control pin: DISP
 - LCD power pins: V0, V1, V2, V3, V4
- ◆ Common / Segment output direction select
 - Master chip: SHL = 0, ADC = 0
 - Slave chip: SHL = 1, ADC = 1

TCP PIN LAYOUT (SAMPLE)

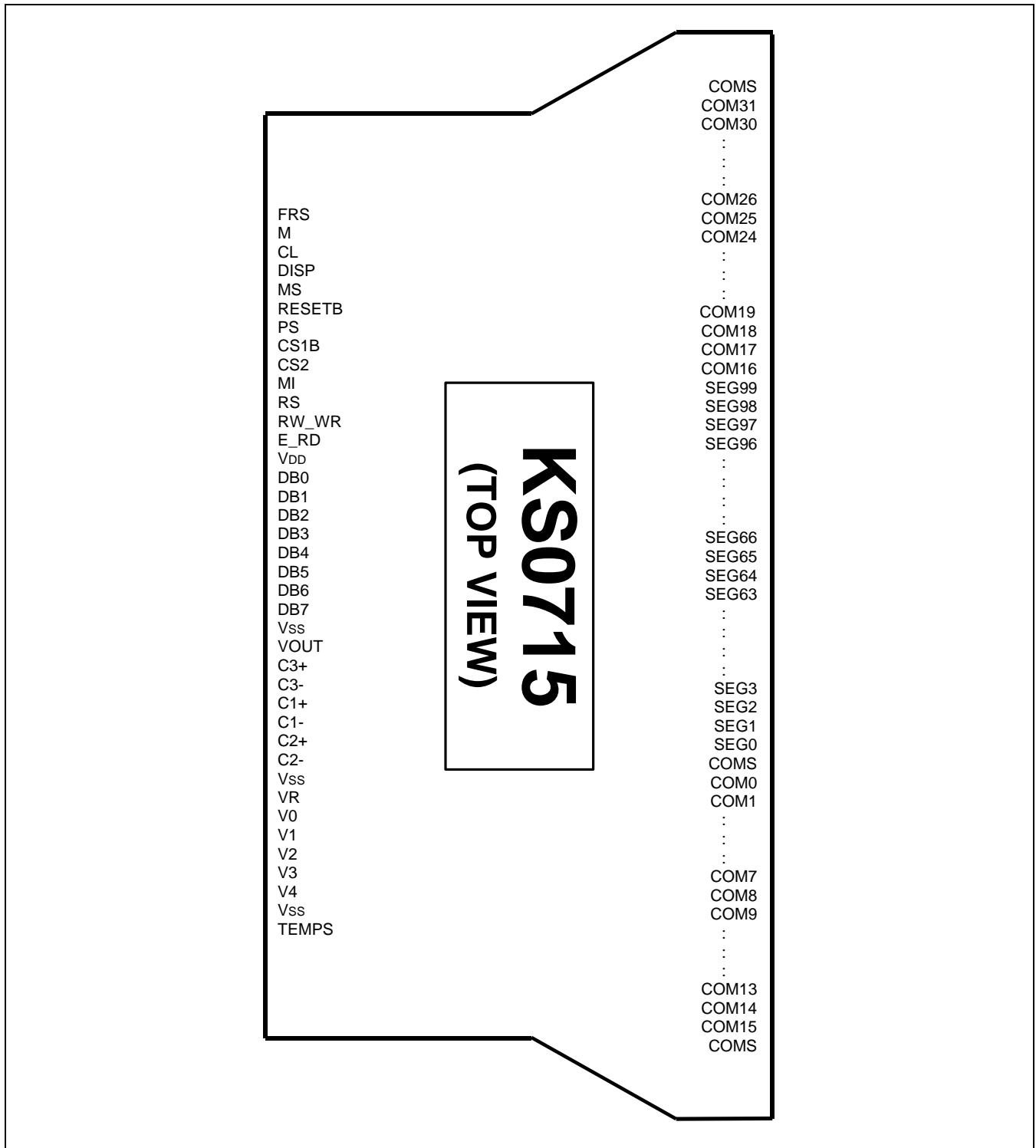

Figure 46. TCP Pin Layout