

### CMOS (TTL Compatible) SJ-460 Series

### Description

The **SJ-460 Series** of quartz crystal oscillators are designed to survive standard wave soldering operations without damage.

### Features

- Wide frequency range—2.25MHz to 36.0MHz
- User specified tolerance available
- Will withstand vapor phase temperatures of 253°C for 4 minutes maximum
- Space-saving alternative to discrete component oscillators
- High shock resistance, to 3000g
- Metal lid electrically connected to ground to reduce EMI
- Low Jitter
- CMOS and TTL output levels
- High Q Crystal actively tuned oscillator circuit
- Low power consumption
- Power supply decoupling internal
- No internal PLL avoids cascading PLL problems
- High frequencies due to proprietary design
- Gold plated leads

### Electrical Connection

Pin	Connection
1	N.C.
2	Ground
3	Output
4	V <sub>DD</sub>

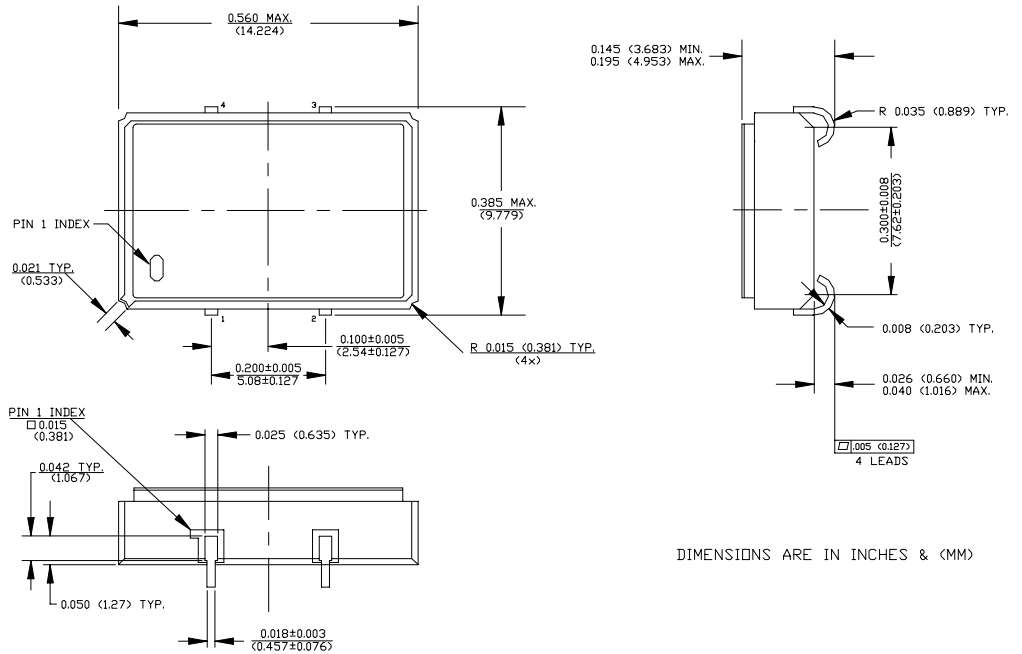

**SJ-460 Series** Continued  
CMOS (TTL Compatible)

Rev. D

### Operating Conditions and Output Characteristics

#### Electrical Characteristics

Parameter	Symbol	Conditions	Min	Typical	Max
Frequency	-----	-----	2.25MHz	-----	36.0MHz
Duty Cycle	-----	@ $V_{DD}/2$	45/55%	-----	55/45%
Logic 0	$V_{OL}$	@ 600 $\mu$ A	-----	-----	0.2V
		@ 16mA	-----	-----	0.4V
Logic 1	$V_{OH}$	@ 600 $\mu$ A	$V_{DD}-0.2V$	-----	-----
		@ 16mA	$V_{DD}-0.4V$	-----	-----
Rise & Fall Time	$t_{r,tf}$	10-90% $V_O$	-----	-----	3 ns
Jitter, RMS <sup>(2)</sup>	-----	-----	-----	-----	8.0 psec
Frequency Stability <sup>(1)</sup>	dF/F	Overall conditions including: voltage, calibration, temp., 10 yr aging, shock, vibration	-100ppm	-----	+100ppm

#### General Characteristics

Parameter	Symbol	Conditions	Min	Typical	Max
Supply Voltage	$V_{DD}$	-----	4.5V	5.0V	5.5V
Supply Current	$I_{DD}$	No Load	0.0 mA	-----	30 mA
Output current	$I_O$	-----	0.0 mA	-----	$\pm 16.0$ mA
Operating temperature	$T_A$	-----	0°C	-----	70°C
Storage temperature	$T_S$	-----	-55°C	-----	125°C
Power Dissipation	$P_D$	-----	-----	-----	210 mW
Lead temperature	$T_L$	Soldering, 10 sec.	-----	-----	300°C
Load	-----	-----	-----	-----	15pf
Start-up Time	$t_s$	<20MHz	-----	-----	2 ms
		20MHz or greater	-----	-----	10 ms

#### Environmental and Mechanical Characteristics

Mechanical Shock	Per MIL-STD-202, Method 213, Condition E
Thermal Shock	Per MIL-STD-833, Method 1011, Condition A
Vibration	0.060" double amplitude 10 Hz to 55 Hz, 35g's 55Hz to 2000 Hz
Soldering Condition	300°C for 10 seconds
Hermetic Seal	Leak rate less than $1 \times 10^{-8}$ atm.cc/sec of helium

#### Footnotes:

- Standard frequency stability ( $\pm 20, \pm 25, \pm 50$ ppm & others available)
- Jitter performance is frequency dependent. Please contact factory for full characterization.

Creating a Part Number	
<b>SJ - A46X - FREQ</b>	
<b>Package Code</b>	<b>Tolerance/Performance</b>
SJ 4 J Lead SMD	0 $\pm 100$ ppm 0-70°C
	1 $\pm 50$ ppm 0-70°C
	7 $\pm 25$ ppm 0-70°C
	9 Customer Specific
<b>Input Voltage</b>	A $\pm 20$ ppm 0-70°C
Code Specification	B $\pm 50$ ppm -40 to +85°C
A 3.3V	C $\pm 100$ ppm -40 to +85°C
5V	

#### Test Load:

