

E500 Series

The cost-effective variable speed control solution for general purpose applications.



- Up to 1 Hp at 115 VAC
- Up to 10 Hp at 240 VAC, 480 and 600 VAC
- Advanced Magnetic Flux Vector Control
- Auto-tuning
- 50°C maximum ambient temperature
- RS-485 serial communication (standard)
- Selectable cooling fan operation mode
- Built-in PID control
- Adjustable carrier frequency (0.7kHz to 14.5kHz)
- Optional keypad interface (FR-PA02-02)
- Compatible with FR-PU04 user interface
- UL & cUL listed / CE marked
- Available configuration software for Windows® 95 / 98
- Open-network communication options
 - DeviceNet
 - CC-Link
 - Profibus DP (400V and 600V only)
- Brake Transistor



www.DataSheet4U.com

Inverter Type

FR-E520 – 0.1 K – NA

Symbol	Voltage Class	Inverter capacity "kW"
E510W	Single-phase 100V class	
E520	Three-phase 200V class	
E540	Three-phase 400V class	
E560	Three-phase 600V class	

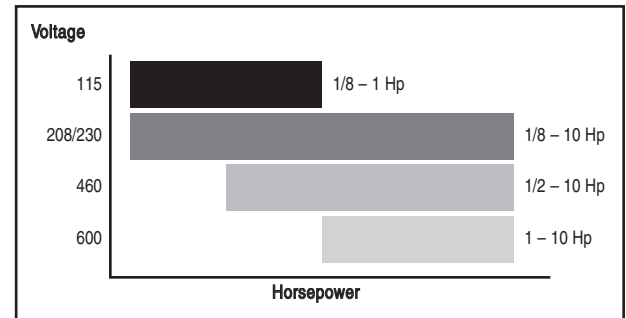

E500 Selection

Rating (CT & VT)		IP20 Open Chassis		Dimensions			Stocked Item		
Hp	Output Current Amps	Model Number	Height mm (in)	Width mm (in)	Depth mm (in)	Weight kg (lbs)			
1-Phase 100 – 115 VAC Input / 3-Phase 230 VAC Output									
1/8	0.8	FR-E510W-0.1K-NA	128 (5.0)	68 (2.7)	76 (3.0)	0.6 (1.4)	–		
1/4	1.5	FR-E510W-0.2K-NA	128 (5.0)	68 (2.7)	106 (4.2)	0.6 (1.4)	S		
1/2	3.0	FR-E510W-0.4K-NA	128 (5.0)	68 (2.7)	138 (5.5)	1.0 (2.2)	S		
1.0	5.0	FR-E510W-0.75K-NA	128 (5.0)	108 (4.3)	155 (6.1)	1.7 (3.8)	S		
200 – 240 VAC Input / 3-Phase 200 – 240 VAC Output									
3-Phase		1-Phase		Model Number	Height mm (in)	Width mm (in)	Depth mm (in)	Weight kg (lbs)	Stocked Item
Hp	amp	Hp	amp						
1/8	0.8	—	—	FR-E520-0.1K-NA	128 (5.0)	68 (2.7)	76 (3.0)	0.6 (1.4)	S
1/4	1.5	—	—	FR-E520-0.2K-NA	128 (5.0)	68 (2.7)	76 (3.0)	0.6 (1.4)	S
1/2	3	1/4	1.5	FR-E520-0.4K-NA	128 (5.0)	68 (2.7)	108 (4.3)	0.8 (1.8)	S
1.0	5	1/2	2.5	FR-E520-0.75K-NA	128 (5.0)	68 (2.7)	128 (5.0)	1.0 (2.2)	S
2.0	8	3/4	4	FR-E520-1.5K-NA	128 (5.0)	108 (4.3)	131 (5.2)	1.7 (3.8)	S
3.0	11	1.0	5	FR-E520-2.2K-NA	128 (5.0)	108 (4.3)	131 (5.2)	1.7 (3.8)	S
5.0	17.5	2.0	7	FR-E520-3.7K-NA	128 (5.0)	170 (6.7)	138 (5.5)	2.2 (4.9)	S
7.5	24	—	—	FR-E520-5.5K-NA	260 (10.2)	180 (7.1)	170 (6.7)	4.4 (9.7)	S
10.0	33	—	—	FR-E520-7.5K-NA	260 (10.2)	180 (7.1)	170 (6.7)	4.9 (10.8)	–
3-Phase 380 – 480 VAC Input / Output									
1/2	1.6	—	—	FR-E540-0.4K-NA	150 (5.9)	140 (5.5)	116 (4.6)	1.9 (4.2)	S
1.0	2.6	—	—	FR-E540-0.75K-NA	150 (5.9)	140 (5.5)	116 (4.6)	1.9 (4.2)	S
2.0	4	—	—	FR-E540-1.5K-NA	150 (5.9)	140 (5.5)	136 (5.4)	2.0 (4.4)	S
3.0	6	—	—	FR-E540-2.2K-NA	150 (5.9)	140 (5.5)	136 (5.4)	2.1 (4.7)	S
5.0	9.5	—	—	FR-E540-3.7K-NA	150 (5.9)	140 (5.5)	136 (5.4)	2.1 (4.7)	S
7.5	12	—	—	FR-E540-5.5K-NA	150 (5.9)	220 (8.7)	148 (5.8)	3.8 (8.4)	S
10.0	17	—	—	FR-E540-7.5K-NA	150 (5.9)	220 (8.7)	148 (5.8)	3.8 (8.4)	S
3-Phase 575 – 600 VAC Input / Output									
1.0	1.7	—	—	FR-E560-0.75K-NA	150 (5.9)	140 (5.5)	136 (5.4)	1.8 (4.0)	S
2.0	2.7	—	—	FR-E560-1.5K-NA	150 (5.9)	140 (5.5)	136 (5.4)	2.0 (4.7)	S
3.0	4.0	—	—	FR-E560-2.2K-NA	150 (5.9)	140 (5.5)	136 (5.4)	2.0 (4.7)	S
5.0	6.1	—	—	FR-E560-3.7K-NA	150 (5.9)	220 (8.7)	148 (5.8)	3.8 (8.4)	S
7.5	9.0	—	—	FR-E560-5.5K-NA	150 (5.9)	220 (8.7)	148 (5.8)	3.8 (8.4)	S
10.0	12	—	—	FR-E560-7.5K-NA	150 (5.9)	220 (8.7)	148 (5.8)	3.8 (8.4)	S

www.DataSheet4U.com

E500 General Specifications

Control Specifications	Control Method		Soft-PWM control / high carrier frequency PWM control can be selected. V / F control or general-purpose magnetic flux vector control can be selected.
	Output Frequency Range		0.2 to 400Hz (starting frequency variable between 0 and 60Hz)
	Frequency Control	Analog Input	Across terminals 2-5: 1/500 of maximum set frequency (5 VDC input), 1/1000 (10 VDC, 4-20mADC input).
		Digital Input	0.01Hz (less than 100Hz), 0.1Hz (100Hz or more) when digital setting is made using the control panel.
	Frequency Precision	Analog Input	Within $\pm 0.5\%$ of maximum output frequency (25°C $\pm 10^\circ\text{C}$) / 59°F to 95°F.
		Digital Input	Within 0.01% of set output frequency when setting is made from control panel.
	Voltage / Frequency Characteristics		Base frequency set as required between 0 and 400Hz. Constant torque or variable torque pattern can be selected.
	Starting Torque		150% or more (at 1Hz), 200% or more (at 3Hz) when general-purpose magnetic flux vector control or slip compensation is selected.
	Torque Boost		Manual torque boost, 0 to 30% may be set.
	Acceleration / Deceleration Time Setting		0.01, 0.1 to 3600 sec. (accel. and decel. can be set individually), linear or S-pattern accel./decel. mode can be selected
	Braking Torque	Regenerative	0.1K, 0.2K...150% or more, 0.4K, 0.75K... 00% or more, 1.5K...50% or more, 2.2K, 3.7K, 5.5K, 7.5K ... 20% or more (*1)
		DC Dynamic Brake	Operation frequency (0 to 120Hz), operation time (0 to 10 s), operation voltage (0 to 30%) variable.
	Stall Prevention Operation Level		Operation current level can be set (0 to 200% variable), presence or absence can be selected.
Voltage Stall Prevention Operation Level		Operation level is fixed, presence or absence can be selected.	
Fast-Response Current Limit Level		Operation level is fixed, presence or absence can be selected.	
Input Signals	Frequency Setting Signal	Analog Input	0 to 5 VDC, 0 to 10 VDC, 4 to 20mADC.
		Digital Input	Entered from control panel (FR-PA02-02).
	Starting Signal		Forward and reverse rotation, start signal automatic self-holding input (3-wire input) can be selected.
	Alarm Reset		Used to reset alarm output provided when protective function is activated.
	Multi-Speed Selection		Up to 15 speeds can be selected. (Each speed can be set between 0 and 400Hz, running speed can be changed during operation from the control panel.)
	Second Function Selection		Used to select second functions (accel. time, decel. time, torque boost, freq., electronic overcurrent protection).
	Output Stop		Instantaneous shut-off of inverter output (frequency, voltage).
	Current Input Selection		Used to select input of frequency setting signal 4 to 20mADC (terminal 4).
	Start Signal Automatic Self-Holding Selection		Used to select start signal automatic self-holding input. (3-wire input)
	External Thermal Relay Input		Thermal relay contact input for use when the inverter is stopped by the external thermal relay.
	PU Operation-External Operation Switching		Used to switch between PU operation and external operation from outside the inverter.
	V/F-General-Purpose Magnetic Flux Switching		Used to switch between V/F control and general-purpose magnetic flux vector from outside the inverter.
	Operation Functions		Maximum/minimum frequency setting, frequency jump operation, external thermal relay input selection, automatic restart operation after instantaneous power failure, forward/reverse rotation prevention, slip comp., operation mode selection, off-line auto tuning function, PID control, computer link operation (RS-485).
Output Signals	Operation Status		2 open collector output signals can be selected from inverter running, up to frequency, frequency detection, overload alarm, zero current detection, output current detection, PID upper limit, PID lower limit, PID forward/reverse rotation, operation ready, minor fault and alarm, and 1 contact output (230 VAC 0.3A, 30 VDC 0.3A) can be selected.
	For Meter		1 signal can be selected from output frequency, motor current and output voltage. Pulse train output (1440 pulses/second/full scale).
Display	Control Panel Display	Operating Status	Output voltage, output current, set frequency, running.
		Alarm Definition	Alarm definition is displayed when protective function is activated. 4 alarm definitions are stored.
	LED Display		Power application (POWER)
Protective And Warning Functions		Overcurrent shut-off (during acceleration, deceleration, constant speed), regenerative overvoltage shut-off, undervoltage (*2), instantaneous power failure (*2), overload shut-off (electronic overcurrent protection), brake transistor alarm, output short circuit, stall prevention, brake resistor overheat protection, fan overheat, fan failure (*4), parameter error, PU disconnection, ground fault protection.	
Environment	Ambient Temperature		Constant torque: -10°C to +50°C (non-freezing) 14°F to 122°F
	Ambient Humidity		90%RH or less (non-condensing)
	Storage Temperature (*3)		-20°C to +65°C / -4°F to 149°F
	Atmosphere		Indoors, no corrosive and flammable gases, oil mist, dust and dirt.
	Altitude		Maximum 1000m (3300 ft.) above sea level for standard operation. After that derate by 3% for every extra 500m up to 2500m (91%).
	Vibration		5.9 m/s ² (0.6G max.) based on JIS C 0911.

Use Pr. 180 to Pr. 183 for selection.

Notes:

- The braking torque indicated is a short-duration average torque (which varies with motor loss) when the motor alone is decelerated from 60Hz in the shortest time and is not a continuous regenerative torque. When the motor is decelerated from the frequency higher than the base frequency, the average deceleration torque will reduce. Since the inverter does not contain a brake resistor, use the optional brake resistor when regenerative energy is large. (The optional brake resistor cannot be used with 0.1K and 0.2K.) A brake unit (BU) may also be used.
- When undervoltage or instantaneous power failure has occurred, alarm display or alarm output is not provided but the inverter itself is protected. Overcurrent, regenerative overvoltage or other protection may be activated at power restoration according to the operating status (load size, etc.).
- Temperature applicable for a short period in transit, etc.
- Not provided for the FR-E520-0.1K to 0.4K and FR-E510W-0.1K to 0.75K which are not equipped with a cooling fan.

E500 Series Terminal Connection Diagram

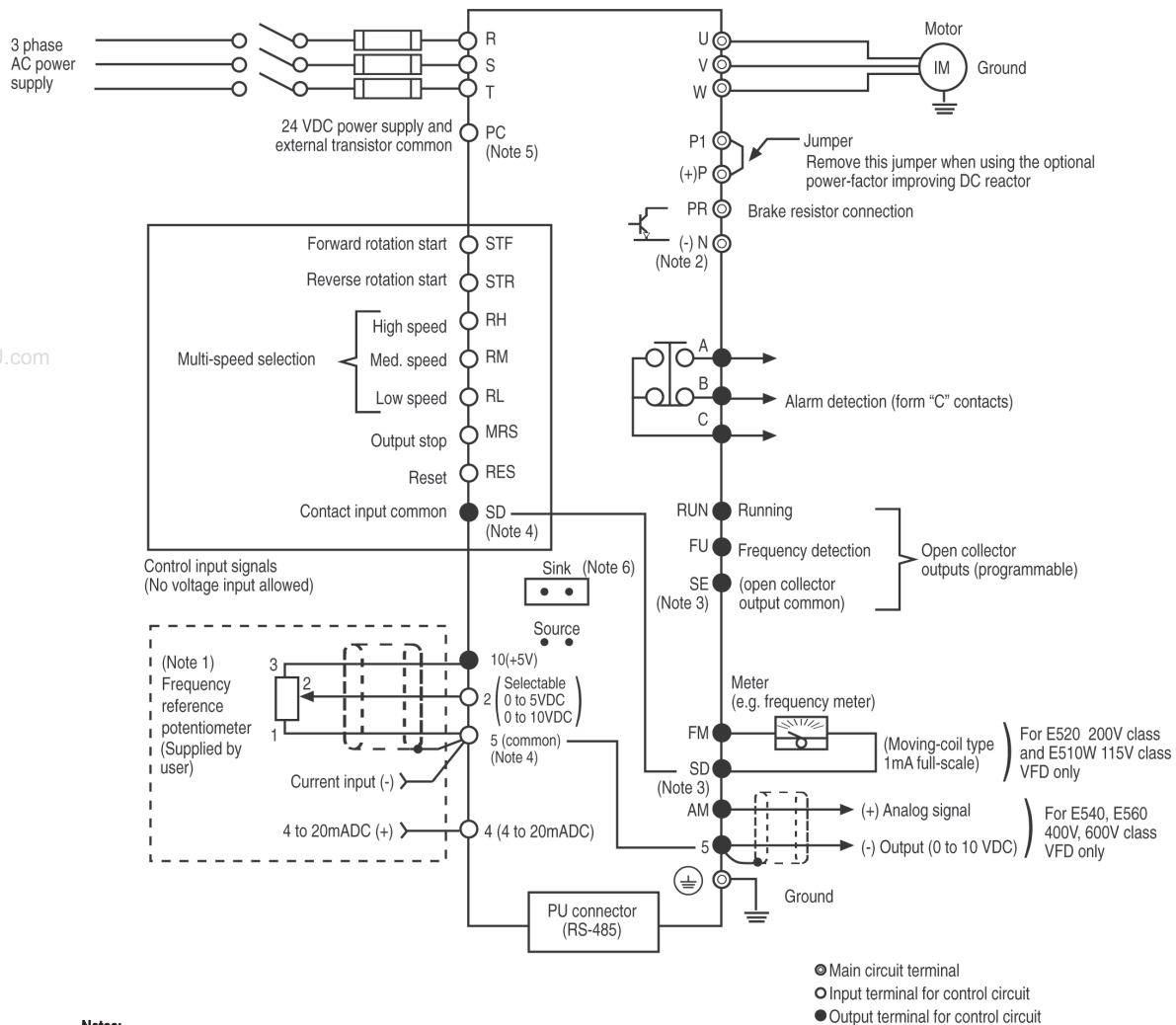

Notes:

1. Use 0.5W, 1kΩ potentiometer. For heavier duty applications, use a 2W, 1kΩ potentiometer.
2. 0.1kW and 0.2kW rated models do not contain braking transistor.
3. Terminals SD and SE are electrically isolated.
4. Terminals SD and 5 are not electrically isolated. Do not connect them to each other or to ground.
5. To avoid damage to the VFD, do not allow a short circuit between terminals PC and SD.

Single-phase 100V power input / three-phase 200V power output

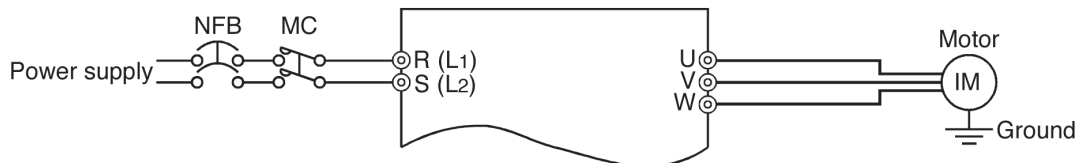

Terminal Block Layout

200V class, 100V class

*AM for the 400, 600V class inverter.

RH	A
RM	B
RL	C
MRS	10
RES	2
SD	5
FM*	4
PC	SD
SE	STF
RUN	STR
FU	SD

400V, 600V class

E500 Series Options

Model Number	Description	Notes	Stocked Item
FR-PA02-02	Keypad for E500 VFD	For mounting on E500 VFD	S
FR-E5P	Keypad Panel Mounting Adapter	For use only on FR-PA02-02 and FR-CB20x	S
FR-DU04	LED Parameter Unit	Also used with A500(L).	-
FR-PU04	LCD Parameter Unit	Also used with A500(L).	S
FR-E5ND	E540, E560 DeviceNet Interface	Plug-in Option. Not for use with E520 or E510W.	S
FR-E5NP	E540, E560 Profibus DP Interface	Plug-in Option. Not for use with E520 or E510W.	S
FR-E5NC	E540, E560 CC-Link Interface	Plug-in Option. Not for use with E520 or E510W.	S
FR-E5NL	E540, E560 LonWorks Interface	Plug-in Option. Not for use with E520 or E510W.	-
FR-E520-□□KND	E520 with Built-In DeviceNet Interface	Same ratings as -NA version. Deeper by 19.6 mm than -NA.	-
FR-E520-□□KN	E520 with Built-In CC-Link Interface	Same ratings as -NA version. Deeper by 19.6 mm than -NA.	-
FR-CB201	Remote cable	1m cable	S
FR-CB203	Remote Cable	3m cable	S
FR-CB205	Remote Cable	5m cable	S
IB(NA)66866	FR-E520/E540/E510W Instruction Manual		-
IB(NA)66864	FR-E520-KN CC-Link Instruction Manual		-
SH(NA)3193	FR-A500 / E500 Technical Manual		-
IB(NA)0600003	FR-E5NC, CC-Link Instruction Manual		-
IB(NA)0600006	FR-E5ND, DeviceNet Instruction Manual		-
IB(NA)0600007	FR-E5NP, Profibus Instruction Manual		-
IB(NA)0600008	FR-E520-KND, DeviceNet Instruction Manual		-
IB(NA)0600204	FR-E560 Instruction Manual	Only available for download.	-
FR-CONFIGURATOR	Programming and Diagnostic Software		S
SC-FRPC	Serial Communication Cable		S

Note: □ represents drive kW rating

Dynamic Braking

All Mitsubishi Electric VFD's have some inherent braking capability. During controlled deceleration, motor regenerative losses are dissipated in the motor, wire, and VFD circuitry. The built-in DC injection braking allows for low speed braking and stopping.

When the above capabilities are inadequate for an application, it is necessary to add a power transistor brake unit and resistor unit in series across the DC bus. Motor regeneration causes the DC bus voltage to increase, and when the voltage exceeds a specified threshold, the transistor turns on to pass current through the resistor. Motor kinetic energy is converted to heat energy. VFD overcurrent and overvoltage protective circuits are active at all times, and will fault-trip the VFD if the brake size is inadequate.

Two main factors must be considered when sizing the brake, the effective duty cycle (%ED) and the short time duty rating. The effective duty cycle is increased when an external resistor is added. It is preferable to profile the effective duty cycle of the units of time. With this information, the short time duty is known and the %ED can be calculated, as shown in the below example.

$$\%ED = \text{Braking time} / \text{total time for complete operating cycle} * 100$$

Example: Complete cycle is:

- 5 sec: Acceleration time to reach set speed
- 60 sec: Run time at set speed
- 3 sec: Deceleration time to come to a complete stop
- 12 sec: Time period motor remains stopped

$$\%ED = 3 / (5 + 60 + 3 + 12) * 100 = 3.6\%$$

The tables shown assume 100% brake torque, when brake torque is represented by its percentage to the rated torque of the applied motor.

$$\text{Torque (kg.m)} = 974 * \text{Power (kW)} / \text{Speed (rpm)}.$$

Dynamic Braking Unit for 230 VAC • Braking Torque = 100%											
Braking Unit Model No. (*3)	Weight kg / lbs	Resistor Kit Model No. (*3)	Stocked Item	Weight kg / lbs	Resistance (Ohms)	Rated (W)	Motor (Hp)	Drive Model			
								E520	% ED	E510W	%ED
Not Necessary (*1)	N/A	FR-ABR-0.4K-UL	S	0.2 / 0.5	200	80	0.5	0.4K	10%	0.4K	10%
		FR-ABR-0.75K-UL	S	0.4 / 0.9	100	150	1	0.75K	10%	0.75K	10%
		FR-ABR-2.2K-UL	S	0.5 / 1.1	60	250	3	1.5K - 2.2K	10%		
		FR-ABR-3.7K-UL	S	0.8 / 1.8	40	300	5	3.7K	10%		
		FR-ABR-5.5K-UL	S	1.3 / 2.9	25	500	7.5	5.5K	10%		
		FR-ABR-7.5K-UL	S	2.2 / 4.9	20	800	10	7.5K	10%		

See notes next page.

E500 Dynamic Braking

Dynamic Braking Unit for 460-480 VAC • Braking torque = 100%									
Braking Unit Model No. (*2)	Weight kg / lbs	Resistor Kit Model No. (*2)	Stocked Item	Weight kg / lbs	Resistance (Ohms)	Rated (W)	Motor (Hp)	Drive Model	
								E540	% ED
Not Necessary (*1)	N/A	FR-ABR-H0.4K-UL	S	0.2 / 0.5	1200	60	0.5	0.4K	10%
		FR-ABR-H0.75K-UL	S	0.2 / 0.5	700	80	1	0.75K	10%
		FR-ABR-H1.5K-UL	S	0.4 / 0.9	350	150	2	1.5K	10%
		FR-ABR-H2.2K-UL	S	0.5 / 1.1	250	250	3	2.2K	10%
		FR-ABR-H3.7K-UL	S	0.8 / 1.8	150	300	5	3.7K	10%
		FR-ABR-H5.5K-UL	S	1.3 / 2.9	110	500	7.5	5.5K	10%
		FR-ABR-H7.5K-UL	S	2.2 / 4.9	75	800	10	7.5K	10%

Notes:

1. The FR-A520-0.4K to 7.5K and FR-V520 - 1.5K to 15K have a built-in braking transistor.
2. Optional brake resistor is only available for FR-E520-0.4K-NA and higher.
3. Products are UL listed.

FR-ABR-0.4K to 7.5K, H0.4K to H7.5K

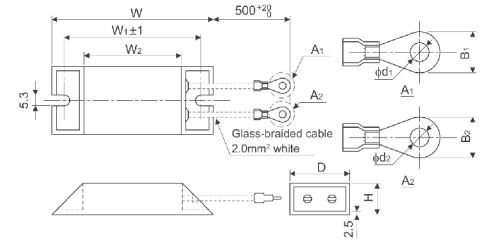

Input Radio Noise Filter

This filter is connected to the input of the drive and helps to reduce radiated noise in the radio frequencies.

Drive Voltage	Kit Model Number	Leakage Current (mA)	Dimensions mm (in)			Stocked Item
			L	W	D	
208 - 230	FR-BIF	4	58 (2.3)	44 (1.8)	42 (1.7)	S
460	FR-BIF-H	4	58 (2.3)	44 (1.8)	42 (1.7)	-

Line Noise Filter

Provides a toroid for line noise reduction.

Drive Hp	Kit Model Number	Dimensions mm (in)			Stocked Item
		L	W	D	
0.5 - 5	FR-BSF01	110 (4.33)	22.5 (0.89)	65 (2.56)	S
0.5 - 75	FR-BLF	180 (7.07)	31.5 (1.24)	83 (3.27)	S

DIN Rail Mounting Attachment

This attachment allows the E500 Series inverter to mount on a 35mm DIN rail.

Model Number	Drive Model		Stocked Item
	E510W	E520	
FR-UDA01	0.1K - 0.4K	0.1K - 0.75K	S
FR-UDA02	0.75K	1.5K - 2.2K	S
FR-UDA03	-	3.7K	-

Installation Interchange Attachment

This attachment allows the E500 Series inverter to be mounted using the installation holes from the previous series VFDs.

Model Number	Installation Model E500 Series	Previous Model			Stocked Item
		A0x4 Series	Z024 Series	A200E Series	
FR-E5T-10	FR-E520-0.1K-NA	FR-A024-0.1K-UL	FR-Z024-0.1K-UL	-	S
	FR-E520-0.2K-NA	FR-A024-0.2K-UL	FR-Z024-0.2K-UL	-	
	FR-E520-0.4K-NA	FR-A024-0.4K-UL	FR-Z024-0.4K-UL	-	
	FR-E520-0.75K-NA	FR-A024-0.75K-UL	-	-	
FR-E5T-11	FR-E520-0.75K-NA	-	FR-Z024-0.75K-UL	-	-
	FR-E520-1.5K-NA	FR-A024-1.5K-UL	FR-Z024-1.5K-UL	-	
FR-E5T	FR-E520-2.2K-NA	FR-A024-2.2K-UL	FR-Z024-2.2K-UL	-	-
	FR-E520-3.7K-NA	FR-A024-3.7K-UL	FR-Z024-3.7K-UL	-	
FR-E5T-02	FR-E520-5.5K-NA	-	-	FR-A220E-5.5K-UL	-
	FR-E520-7.5K-NA	-	-	FR-A220E-7.5K-UL	
Direct Attachment	FR-E540-0.4K-NA	FR-A044-0.4K-UL	-	-	-
	FR-E540-0.75K-NA	FR-A044-0.75K-UL	-	-	
FR-E5T-14	FR-E540-1.5K-NA	FR-A044-1.5K-UL	-	-	-
	FR-E540-2.2K-NA	FR-A044-2.2K-UL	-	-	
	FR-E540-3.7K-NA	FR-A044-3.7K-UL	-	-	

E500 Installation Interchange Attachment

This attachment allows the E500 Series inverter to be mounted at a 90° angle so that the depth is reduced to 80 mm.

Model Number	Installation Model	Previous Model		Stocked Item
	E500 Series	A0x4 Series	Z024 Series	
FR-E5T-L	FR-E520-0.4K-NA	FR-A024-0.4K-UL	FR-Z024-0.4K-UL	-
	FR-E520-0.75K-NA	FR-A024-0.75K-UL	—	

E500 Series Watt Loss and Efficiency Data

HP-CT	240VAC 3-Phase Input or 1-Phase Input				480VAC 3-Phase Input			
	Model Number	Rated Watts	Watts Loss	Efficiency	Model Number	Rated Watts	Watts Loss	Efficiency
1/8	FR-E520-0.1K-NA	100	16	84%	—	—	—	—
1/4	FR-E520-0.2K-NA	200	20	90%	—	—	—	—
1/20	FR-E520-0.4K-NA	400	45	89%	FR-E540-0.4K-NA	400	45	89%
1	FR-E520-0.75K-NA	750	50	93%	FR-E540-0.75K-NA	750	50	93%
2	FR-E520-1.5K-NA	1500	85	94%	FR-E540-1.5K-NA	1500	85	94%
3	FR-E520-2.2K-NA	2200	100	95%	FR-E540-4.4K-NA	2200	100	95%
5	FR-E520-3.7K-NA	3700	160	96%	FR-E540-3.7K-NA	3700	160	96%
7.5	FR-E520-5.5K-NA	5500	310	94%	FR-E540-5.5K-NA	5500	310	94%
10	FR-E520-7.5K-NA	7500	420	94%	FR-E540-7.5K-NA	7500	420	94%

General Notes:

1. The amount of heat generated by the inverter is based on one inverter connected to one motor of the same capacity.
2. The amount of heat generated in the above table is the amount of heat generated when the inverter is operated at it's rated current.
3. The amount of heat generated will decrease according to the motor load and usage (duty).

E540 EMC Filters

This attachment allows the VFD to be mounted onto the filter.

Model Number	Installation Mode	Stocked Item
FFR-E540-4.5A-SF1	FR-E540-0.4K – 0.75K	S
FFR-E540-15A-SF1	FR-E540-1.5K – 3.7K	-
FFR-E540-27A-SF1	FR-E540-5.5K – 7.5K	-