

SIEMENS

Microcomputer Components

16-Bit CMOS Single-Chip Microcontroller

C165

C16x-Family of High-Performance CMOS 16-Bit Microcontrollers

C165

Preliminary

C165 16-Bit Microcontroller

- High Performance 16-bit CPU with 4-Stage Pipeline
- 100 ns Instruction Cycle Time at 20-MHz CPU Clock
- 500 ns Multiplication (16 × 16 bits), 1 μs Division (32 / 16 bit)
- Enhanced Boolean Bit Manipulation Facilities
- Additional Instructions to Support HLL and Operating Systems
- Register-Based Design with Multiple Variable Register Banks
- Single-Cycle Context Switching Support
- Up to 16 MBytes Linear Address Space for Code and Data
- 2 KBytes On-Chip RAM
- 4 KBytes On-Chip ROM (RM types only)
- Programmable External Bus Characteristics for Different Address Ranges
- 8-Bit or 16-Bit External Data Bus
- Multiplexed or Demultiplexed External Address/Data Buses
- Five Programmable Chip-Select Signals
- Hold- and Hold-Acknowledge Bus Arbitration Support
- 1024 Bytes On-Chip Special Function Register Area
- Idle and Power Down Modes
- 8-Channel Interrupt-Driven Single-Cycle Data Transfer Facilities via Peripheral Event Controller (PEC)
- 16-Priority-Level Interrupt System with 28 Sources, Sample-Rate down to 50 ns
- Two Multi-Functional General Purpose Timer Units with 5 Timers
- Two Serial Channels (Synchronous/Asynchronous and High-Speed-Synchronous)
- Programmable Watchdog Timer
- Up to 77 General Purpose I/O Lines
- Supported by a Wealth of Development Tools like C-Compilers, Macro-Assembler Packages, Emulators, Evaluation Boards, HLL-Debuggers, Simulators, Logic Analyzer Disassemblers, Programming Boards
- On-Chip Bootstrap Loader
- 100-Pin MQFP Package (EIAJ)
- 100-Pin TQFP Package (Thin QFP)

09.94 Data Sheet Addendum – Attention

The C165 is offered in two different packages:

P-MQFP-100: rectangular package

P-TQFP-100: square package.

For the pin configurations please refer to page 3 (P-MQFP-100) and page 8 (P-TQFP-100) of the 09.94 C165 Data Sheet. Please note that the table “Pin Definition and Functions” on pages 9 through 12 lists the pin numbers for the **MQFP package only**.

The pin numbers for the TQFP package are different and should be taken from the pin configuration on page 3.

Introduction

The C165 is a new derivative of the Siemens SAB 80C166 family of full featured single-chip CMOS microcontrollers. It combines high CPU performance (up to 10 million instructions per second) with high peripheral functionality and enhanced IO-capabilities.

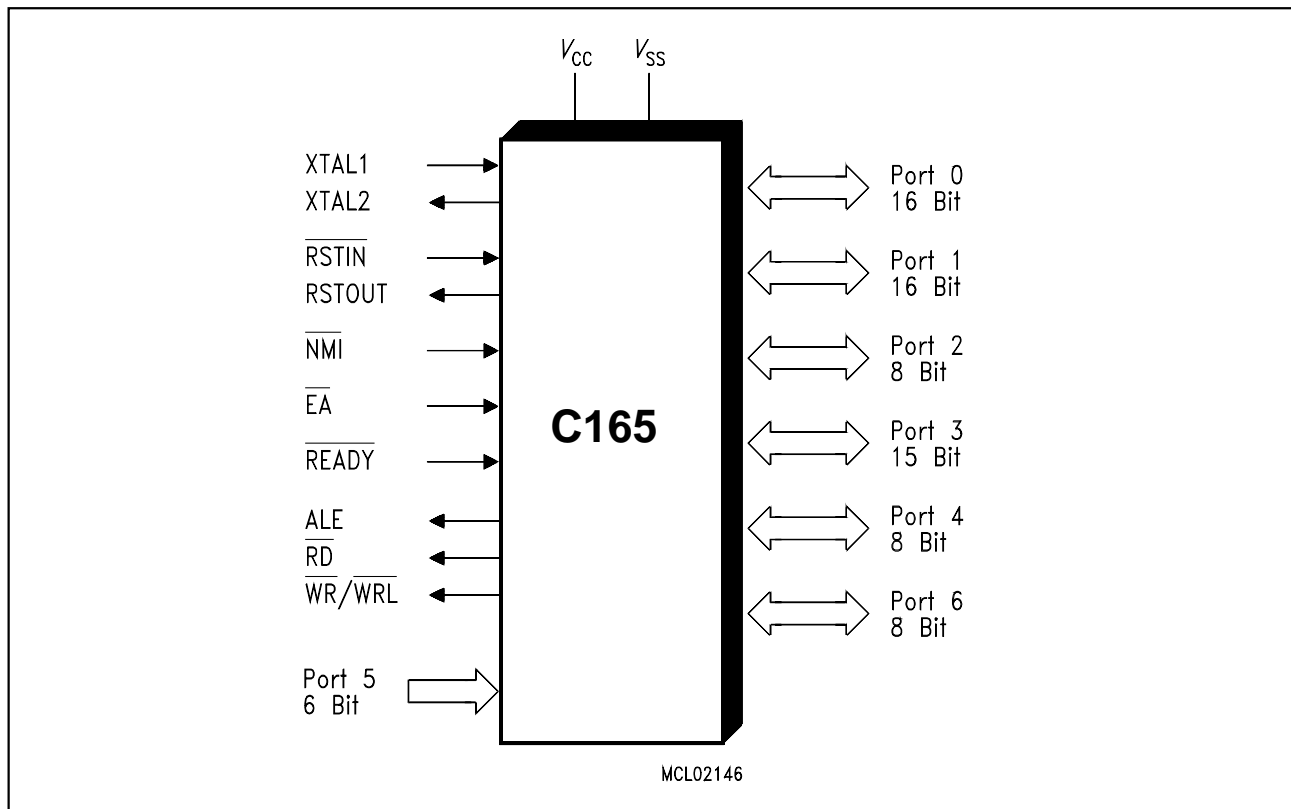

Figure 1
Logic Symbol

Ordering Information

Type	Ordering Code	Package	Function
SAB-C165-RM	Q67121-D...	P-MQFP-100-2	16-bit microcontroller with 2 KByte RAM and 4 KByte ROM Temperature range 0 to +70 °C
SAB-C165-LM	Q67121-C862	P-MQFP-100-2	16-bit microcontroller with 2 KByte RAM Temperature range 0 to +70 °C
SAF-C165-LM	Q67121-C923	P-MQFP-100-2	16-bit microcontroller with 2 KByte RAM Temperature range -40 to +85 °C

Note: The ordering codes (Q67121-D...) for the Mask-ROM versions are defined for each product after verification of the respective ROM code.

Ordering Information

Type	Ordering Code	Package	Function
SAB-C165-RF	Q67121-D...	P-TQFP-100-3	16-bit microcontroller with 2 KByte RAM and 4 KByte ROM Temperature range 0 to +70 °C
SAB-C165-LF	Q67121-C941	P-TQFP-100-3	16-bit microcontroller with 2 KByte RAM Temperature range 0 to +70 °C

Note: The ordering codes (Q67121-D...) for the Mask-ROM versions are defined for each product after verification of the respective ROM code.

Pin Configuration TQFP Package (top view)

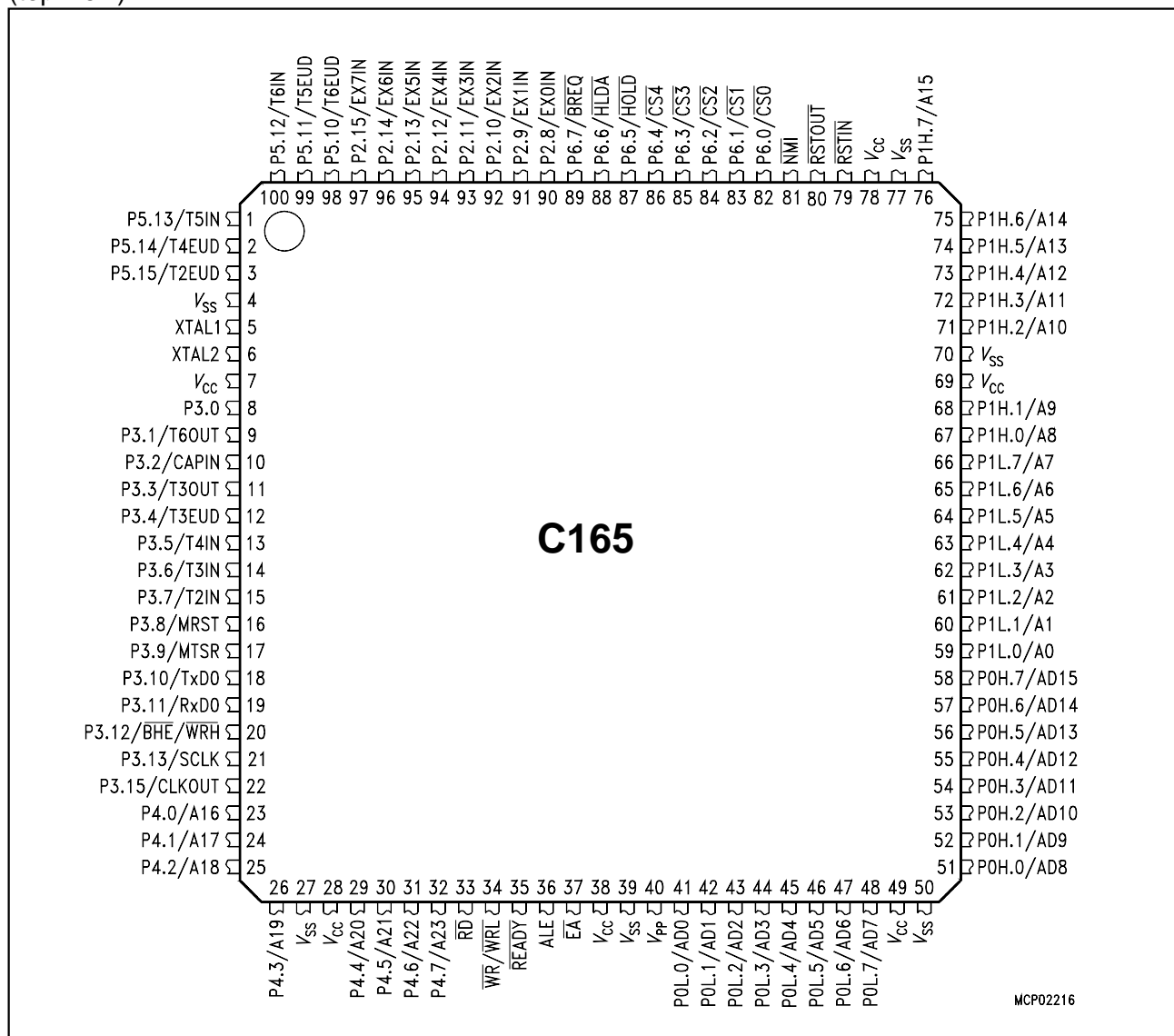

Figure 2

Pin Configuration MQFP Package
(top view)

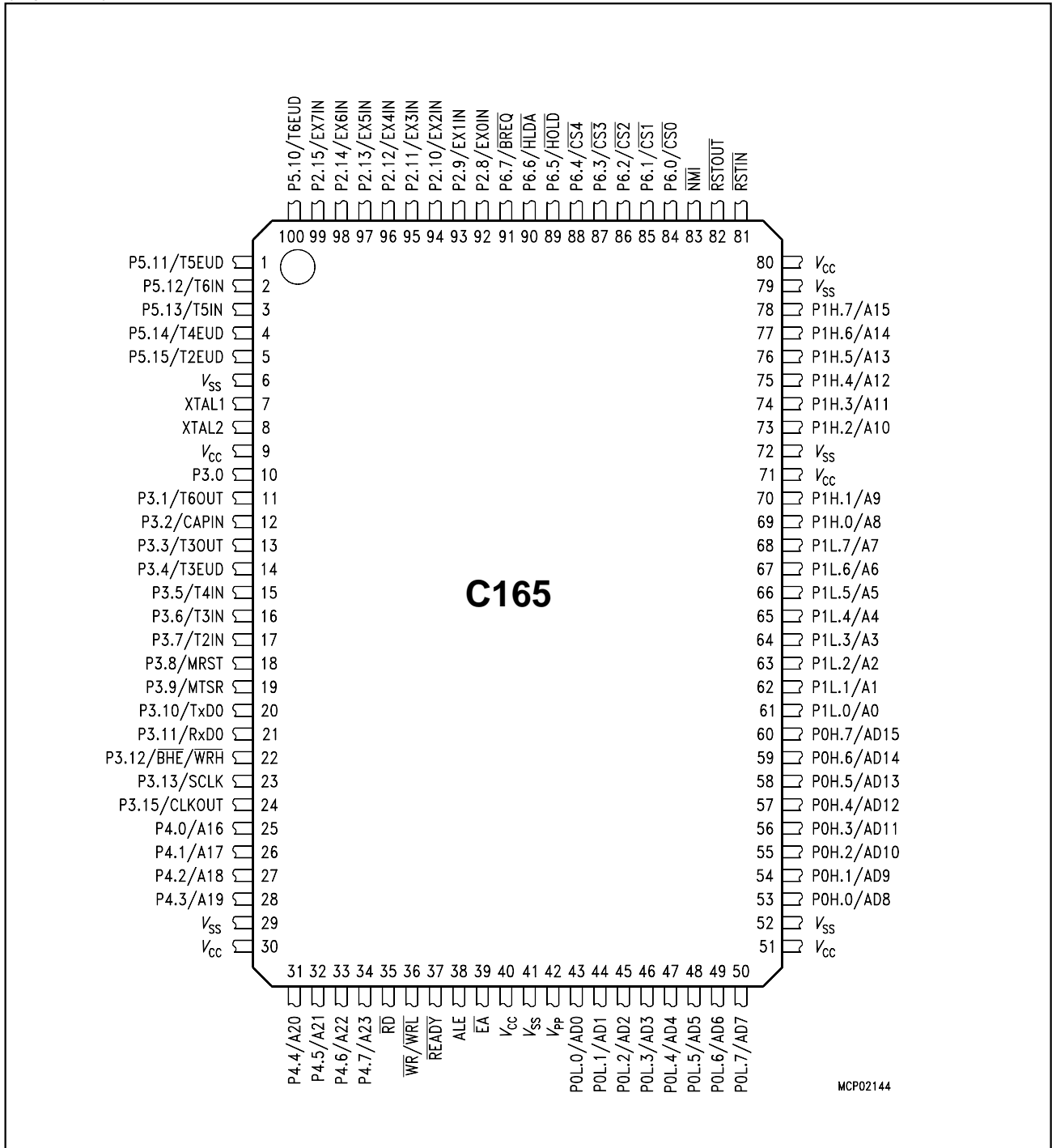

Figure 3

Pin Definitions and Functions

Symbol	Pin No.	Input (I) Output (O)	Function
P5.10 – P5.15	100 1 - 5 100 1 2 3 4 5	I I I I I I I	Port 5 is a 6-bit input-only port with Schmitt-Trigger characteristics. The pins of Port 5 also serve as timer inputs: P5.10 T6EUD GPT2 Timer T6 Ext.Up/Down Ctrl.Input P5.11 T5EUD GPT2 Timer T5 Ext.Up/Down Ctrl.Input P5.12 T6IN GPT2 Timer T6 Count Input P5.13 T5IN GPT2 Timer T5 Count Input P5.14 T4EUD GPT1 Timer T4 Ext.Up/Down Ctrl.Input P5.15 T2EUD GPT1 Timer T2 Ext.Up/Down Ctrl.Input
XTAL1	7	I	XTAL1: Input to the oscillator amplifier and input to the internal clock generator
XTAL2	8	O	XTAL2: Output of the oscillator amplifier circuit. To clock the device from an external source, drive XTAL1, while leaving XTAL2 unconnected. Minimum and maximum high/low and rise/fall times specified in the AC Characteristics must be observed.
P3.0 – P3.13, P3.15	10 – 23, 24 11 12 13 14 15 16 17 18 19 20 21 22 23 24	I/O I/O I/O O I O I I I I I/O I/O O I/O O O I/O O	Port 3 is a 15-bit (P3.14 is missing) bidirectional I/O port. It is bit-wise programmable for input or output via direction bits. For a pin configured as input, the output driver is put into high-impedance state. Port 3 outputs can be configured as push/pull or open drain drivers. The following Port 3 pins also serve for alternate functions: P3.1 T6OUT GPT2 Timer T6 Toggle Latch Output P3.2 CAPIN GPT2 Register CAPREL Capture Input P3.3 T3OUT GPT1 Timer T3 Toggle Latch Output P3.4 T3EUD GPT1 Timer T3 Ext.Up/Down Ctrl.Input P3.5 T4IN GPT1 Timer T4 Input for Count/Gate/Reload/Capture P3.6 T3IN GPT1 Timer T3 Count/Gate Input P3.7 T2IN GPT1 Timer T2 Input for Count/Gate/Reload/Capture P3.8 MRST SSC Master-Rec./Slave-Transmit I/O P3.9 MTSR SSC Master-Transmit/Slave-Rec. O/I P3.10 TxD0 ASC0 Clock/Data Output (Asyn./Syn.) P3.11 RxD0 ASC0 Data Input (Asyn.) or I/O (Syn.) P3.12 BHE Ext. Memory High Byte Enable Signal, WRH Ext. Memory High Byte Write Strobe P3.13 SCLK SSC Master Clock Outp./Slave Cl. Inp. P3.15 CLKOUT System Clock Output (=CPU Clock)

Pin Definitions and Functions (cont'd)

Symbol	Pin No.	Input (I) Output (O)	Function
P4.0 – P4.7	25 - 28, 31 - 34	I/O	Port 4 is an 8-bit bidirectional I/O port. It is bit-wise programmable for input or output via direction bits. For a pin configured as input, the output driver is put into high-impedance state. In case of an external bus configuration, Port 4 can be used to output the segment address lines: P4.0 A16 Least Significant Segment Addr. Line P4.7 A23 Most Significant Segment Addr. Line
\overline{RD}	35	O	External Memory Read Strobe. \overline{RD} is activated for every external instruction or data read access.
$\overline{WR}/$ \overline{WRL}	36	O	External Memory Write Strobe. In \overline{WR} -mode this pin is activated for every external data write access. In \overline{WRL} -mode this pin is activated for low byte data write accesses on a 16-bit bus, and for every data write access on an 8-bit bus. See WRCFG in register SYSCON for mode selection.
\overline{READY}	37	I	Ready Input. When the Ready function is enabled, a high level at this pin during an external memory access will force the insertion of memory cycle time waitstates until the pin returns to a low level.
ALE	38	O	Address Latch Enable Output. Can be used for latching the address into external memory or an address latch in the multiplexed bus modes.
\overline{EA}	39	I	External Access Enable pin. A low level at this pin during and after Reset forces the C165 to begin instruction execution out of external memory. A high level forces execution out of the internal ROM. The C165 must have this pin tied to '0'.

Pin Definitions and Functions (cont'd)

Symbol	Pin No.	Input (I) Output (O)	Function																		
PORT0: P0L.0 – P0L.7, P0H.0 - P0H.7	43 – 50 53 – 60	I/O	<p>PORT0 consists of the two 8-bit bidirectional I/O ports P0L and P0H. It is bit-wise programmable for input or output via direction bits. For a pin configured as input, the output driver is put into high-impedance state.</p> <p>In case of an external bus configuration, PORT0 serves as the address (A) and address/data (AD) bus in multiplexed bus modes and as the data (D) bus in demultiplexed bus modes.</p> <p>Demultiplexed bus modes:</p> <table> <tr> <td>Data Path Width:</td> <td>8-bit</td> <td>16-bit</td> </tr> <tr> <td>P0L.0 – P0L.7:</td> <td>D0 – D7</td> <td>D0 - D7</td> </tr> <tr> <td>P0H.0 – P0H.7:</td> <td>I/O</td> <td>D8 - D15</td> </tr> </table> <p>Multiplexed bus modes:</p> <table> <tr> <td>Data Path Width:</td> <td>8-bit</td> <td>16-bit</td> </tr> <tr> <td>P0L.0 – P0L.7:</td> <td>AD0 – AD7</td> <td>AD0 - AD7</td> </tr> <tr> <td>P0H.0 – P0H.7:</td> <td>A8 - A15</td> <td>AD8 - AD15</td> </tr> </table>	Data Path Width:	8-bit	16-bit	P0L.0 – P0L.7:	D0 – D7	D0 - D7	P0H.0 – P0H.7:	I/O	D8 - D15	Data Path Width:	8-bit	16-bit	P0L.0 – P0L.7:	AD0 – AD7	AD0 - AD7	P0H.0 – P0H.7:	A8 - A15	AD8 - AD15
Data Path Width:	8-bit	16-bit																			
P0L.0 – P0L.7:	D0 – D7	D0 - D7																			
P0H.0 – P0H.7:	I/O	D8 - D15																			
Data Path Width:	8-bit	16-bit																			
P0L.0 – P0L.7:	AD0 – AD7	AD0 - AD7																			
P0H.0 – P0H.7:	A8 - A15	AD8 - AD15																			
PORT1: P1L.0 – P1L.7, P1H.0 - P1H.7	61 - 68 69 - 70, 73 - 78	I/O	<p>PORT1 consists of the two 8-bit bidirectional I/O ports P1L and P1H. It is bit-wise programmable for input or output via direction bits. For a pin configured as input, the output driver is put into high-impedance state. PORT1 is used as the 16-bit address bus (A) in demultiplexed bus modes and also after switching from a demultiplexed bus mode to a multiplexed bus mode.</p>																		
$\overline{\text{RSTIN}}$	81	I	<p>Reset Input with Schmitt-Trigger characteristics. A low level at this pin for a specified duration while the oscillator is running resets the C165. An internal pullup resistor permits power-on reset using only a capacitor connected to V_{SS}.</p>																		
$\overline{\text{RSTOUT}}$	82	O	<p>Internal Reset Indication Output. This pin is set to a low level when the part is executing either a hardware-, a software- or a watchdog timer reset. $\overline{\text{RSTOUT}}$ remains low until the EINIT (end of initialization) instruction is executed.</p>																		
$\overline{\text{NMI}}$	83	I	<p>Non-Maskable Interrupt Input. A high to low transition at this pin causes the CPU to vector to the NMI trap routine. When the PWRDN (power down) instruction is executed, the $\overline{\text{NMI}}$ pin must be low in order to force the C165 to go into power down mode. If $\overline{\text{NMI}}$ is high, when PWRDN is executed, the part will continue to run in normal mode.</p> <p>If not used, pin $\overline{\text{NMI}}$ should be pulled high externally.</p>																		

Pin Definitions and Functions (cont'd)

Symbol	Pin No.	Input (I) Output (O)	Function
P6.0 – P6.7	84 - 91	I/O	Port 6 is an 8-bit bidirectional I/O port. It is bit-wise programmable for input or output via direction bits. For a pin configured as input, the output driver is put into high-impedance state. Port 6 outputs can be configured as push/pull or open drain drivers. The following Port 6 pins also serve for alternate functions:
	84	O	P6.0 $\overline{CS0}$ Chip Select 0 Output

	88	O	P6.4 $\overline{CS4}$ Chip Select 4 Output
	89	I	P6.5 \overline{HOLD} External Master Hold Request Input
	90	O	P6.6 \overline{HLDA} Hold Acknowledge Output
	91	O	P6.7 \overline{BREQ} Bus Request Output
P2.8 – P2.15	92 - 99	I/O	Port 2 is an 8-bit bidirectional I/O port. It is bit-wise programmable for input or output via direction bits. For a pin configured as input, the output driver is put into high-impedance state. Port 2 outputs can be configured as push/pull or open drain drivers. The following Port 2 pins also serve for alternate functions:
	92	I	P2.8 EX0IN Fast External Interrupt 0 Input

	99	I	P2.15 EX7IN Fast External Interrupt 7 Input
V_{PP}	42	-	Flash programming voltage. This pin accepts the programming voltage for flash versions of the C165. Note: This pin is not connected (NC) on non-flash versions.
V_{CC}	9, 30, 40, 51, 71, 80	-	Digital Supply Voltage: + 5 V during normal operation and idle mode. ≥ 2.5 V during power down mode
V_{SS}	6, 29, 41, 52, 72, 79	-	Digital Ground.

Functional Description

The architecture of the C165 combines advantages of both RISC and CISC processors and of advanced peripheral subsystems in a very well-balanced way. The following block diagram gives an overview of the different on-chip components and of the advanced, high bandwidth internal bus structure of the C165.

Note: All time specifications refer to a CPU clock of 20 MHz
(see definition in the AC Characteristics section).

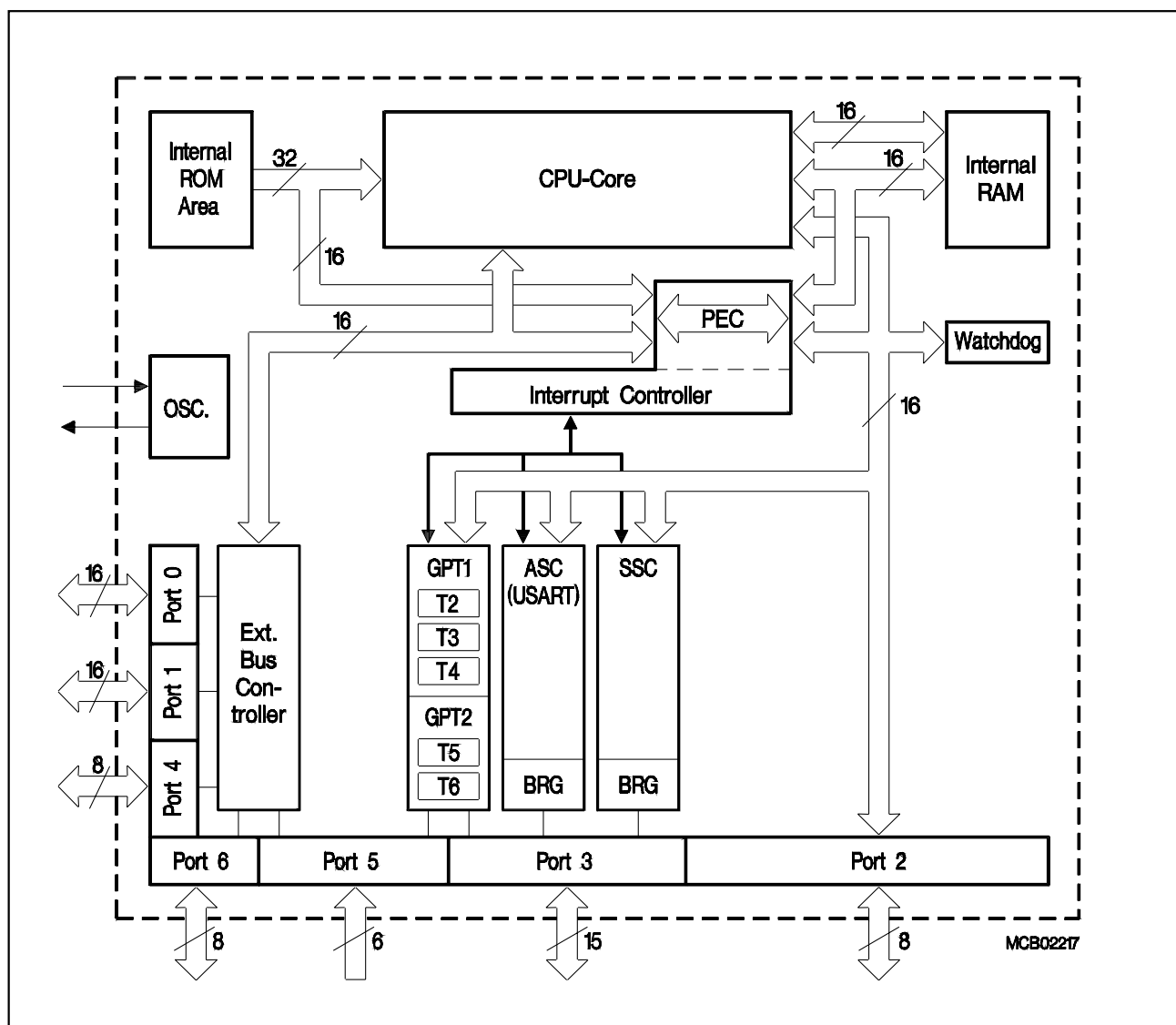

Figure 4
Block Diagram

Memory Organization

The memory space of the C165 is configured in a Von Neumann architecture which means that code memory, data memory, registers and I/O ports are organized within the same linear address space which includes 16 MBytes. The entire memory space can be accessed bitwise or wordwise. Particular portions of the on-chip memory have additionally been made directly bit addressable.

The C165 is prepared to incorporate on-chip mask-programmable ROM for code or constant data. Currently no ROM is integrated.

2 KBytes of on-chip RAM are provided as a storage for user defined variables, for the system stack, general purpose register banks and even for code. A register bank can consist of up to 16 wordwide (R0 to R15) and/or bitwise (RL0, RH0, ..., RL7, RH7) so-called General Purpose Registers (GPRs).

1024 bytes (2 * 512 bytes) of the address space are reserved for the Special Function Register areas (SFR space and ESFR space). SFRs are wordwide registers which are used for controlling and monitoring functions of the different on-chip units. Unused SFR addresses are reserved for future members of the C165 family.

In order to meet the needs of designs where more memory is required than is provided on chip, up to 16 MBytes of external RAM and/or ROM can be connected to the microcontroller.

External Bus Controller

All of the external memory accesses are performed by a particular on-chip External Bus Controller (EBC). It can be programmed either to Single Chip Mode when no external memory is required, or to one of four different external memory access modes, which are as follows:

- 16-/18-/20-/24-bit Addresses, 16-bit Data, Demultiplexed
- 16-/18-/20-/24-bit Addresses, 16-bit Data, Multiplexed
- 16-/18-/20-/24-bit Addresses, 8-bit Data, Multiplexed
- 16-/18-/20-/24-bit Addresses, 8-bit Data, Demultiplexed

In the demultiplexed bus modes, addresses are output on PORT1 and data is input/output on PORT0. In the multiplexed bus modes both addresses and data use PORT0 for input/output.

Important timing characteristics of the external bus interface (Memory Cycle Time, Memory Tri-State Time, Length of ALE and Read Write Delay) have been made programmable to allow the user the adaption of a wide range of different types of memories. In addition, different address ranges may be accessed with different bus characteristics. Up to 5 external \overline{CS} signals can be generated in order to save external glue logic. Access to very slow memories is supported via a particular 'Ready' function. A $\overline{HOLD}/HLDA$ protocol is available for bus arbitration.

For applications which require less than 16 MBytes of external memory space, this address space can be restricted to 1 MByte, 256 KByte or to 64 KByte. In this case Port 4 outputs four, two or no address lines at all. It outputs all 8 address lines, if an address space of 16 MBytes is used.

Central Processing Unit (CPU)

The main core of the CPU consists of a 4-stage instruction pipeline, a 16-bit arithmetic and logic unit (ALU) and dedicated SFRs. Additional hardware has been spent for a separate multiply and divide unit, a bit-mask generator and a barrel shifter.

Based on these hardware provisions, most of the C165's instructions can be executed in just one machine cycle which requires 100 ns at 20-MHz CPU clock. For example, shift and rotate instructions are always processed during one machine cycle independent of the number of bits to be shifted. All multiple-cycle instructions have been optimized so that they can be executed very fast as well: branches in 2 cycles, a 16 × 16 bit multiplication in 5 cycles and a 32-/16 bit division in 10 cycles. Another pipeline optimization, the so-called 'Jump Cache', allows reducing the execution time of repeatedly performed jumps in a loop from 2 cycles to 1 cycle.

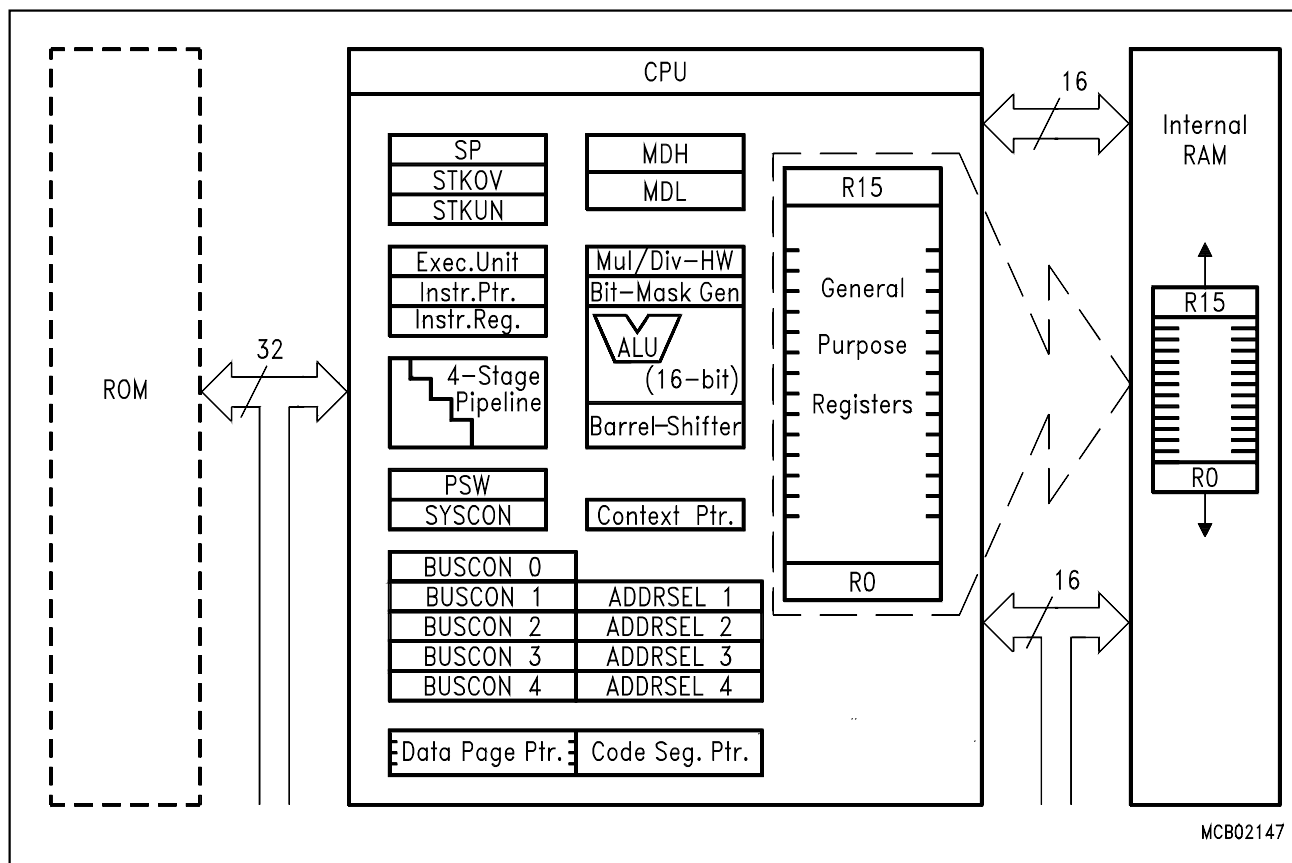

Figure 5
CPU Block Diagram

The CPU disposes of an actual register context consisting of up to 16 wordwide GPRs which are physically allocated within the on-chip RAM area. A Context Pointer (CP) register determines the base address of the active register bank to be accessed by the CPU at a time. The number of register banks is only restricted by the available internal RAM space. For easy parameter passing, a register bank may overlap others.

A system stack of up to 2048 bytes is provided as a storage for temporary data. The system stack is allocated in the on-chip RAM area, and it is accessed by the CPU via the stack pointer (SP) register. Two separate SFRs, STKOV and STKUN, are implicitly compared against the stack pointer value upon each stack access for the detection of a stack overflow or underflow.

The high performance offered by the hardware implementation of the CPU can efficiently be utilized by a programmer via the highly efficient C165 instruction set which includes the following instruction classes:

- Arithmetic Instructions
- Logical Instructions
- Boolean Bit Manipulation Instructions
- Compare and Loop Control Instructions
- Shift and Rotate Instructions
- Prioritize Instruction
- Data Movement Instructions
- System Stack Instructions
- Jump and Call Instructions
- Return Instructions
- System Control Instructions
- Miscellaneous Instructions

The basic instruction length is either 2 or 4 bytes. Possible operand types are bits, bytes and words. A variety of direct, indirect or immediate addressing modes are provided to specify the required operands.

Interrupt System

With an interrupt response time within a range from just 250 ns to 600 ns (in case of internal program execution), the C165 is capable of reacting very fast to the occurrence of non-deterministic events.

The architecture of the C165 supports several mechanisms for fast and flexible response to service requests that can be generated from various sources internal or external to the microcontroller. Any of these interrupt requests can be programmed to being serviced by the Interrupt Controller or by the Peripheral Event Controller (PEC).

In contrast to a standard interrupt service where the current program execution is suspended and a branch to the interrupt vector table is performed, just one cycle is 'stolen' from the current CPU activity to perform a PEC service. A PEC service implies a single byte or word data transfer between any two memory locations with an additional increment of either the PEC source or the destination pointer. An individual PEC transfer counter is implicitly decremented for each PEC service except when performing in the continuous transfer mode. When this counter reaches zero, a standard interrupt is performed to the corresponding source related vector location. PEC services are very well suited, for example, for supporting the transmission or reception of blocks of data. The C165 has 8 PEC channels each of which offers such fast interrupt-driven data transfer capabilities.

A separate control register which contains an interrupt request flag, an interrupt enable flag and an interrupt priority bitfield exists for each of the possible interrupt sources. Via its related register, each source can be programmed to one of sixteen interrupt priority levels. Once having been accepted by the CPU, an interrupt service can only be interrupted by a higher prioritized service request. For the standard interrupt processing, each of the possible interrupt sources has a dedicated vector location.

Fast external interrupt inputs are provided to service external interrupts with high precision requirements. These fast interrupt inputs feature programmable edge detection (rising edge, falling edge or both edges).

Software interrupts are supported by means of the 'TRAP' instruction in combination with an individual trap (interrupt) number.

The following table shows all of the possible C165 interrupt sources and the corresponding hardware-related interrupt flags, vectors, vector locations and trap (interrupt) numbers:

Note: Four nodes in the table (X-Peripheral nodes) are prepared to accept interrupt requests from integrated X-Bus peripherals. Nodes, where no X-Peripherals are connected, may be used to generate software controlled interrupt requests by setting the respective XPnIR bit. Also the three listed Software Nodes can be used for this purpose.

Source of Interrupt or PEC Service Request	Request Flag	Enable Flag	Interrupt Vector	Vector Location	Trap Number
External Interrupt 0	CC8IR	CC8IE	CC8INT	00'0060 _H	18 _H
External Interrupt 1	CC9IR	CC9IE	CC9INT	00'0064 _H	19 _H
External Interrupt 2	CC10IR	CC10IE	CC10INT	00'0068 _H	1A _H
External Interrupt 3	CC11IR	CC11IE	CC11INT	00'006C _H	1B _H
External Interrupt 4	CC12IR	CC12IE	CC12INT	00'0070 _H	1C _H
External Interrupt 5	CC13IR	CC13IE	CC13INT	00'0074 _H	1D _H
External Interrupt 6	CC14IR	CC14IE	CC14INT	00'0078 _H	1E _H
External Interrupt 7	CC15IR	CC15IE	CC15INT	00'007C _H	1F _H
GPT1 Timer 2	T2IR	T2IE	T2INT	00'0088 _H	22 _H
GPT1 Timer 3	T3IR	T3IE	T3INT	00'008C _H	23 _H
GPT1 Timer 4	T4IR	T4IE	T4INT	00'0090 _H	24 _H
GPT2 Timer 5	T5IR	T5IE	T5INT	00'0094 _H	25 _H
GPT2 Timer 6	T6IR	T6IE	T6INT	00'0098 _H	26 _H
GPT2 CAPREL Register	CRIR	CRIE	CRINT	00'009C _H	27 _H
ASC0 Transmit	S0TIR	S0TIE	S0TINT	00'00A8 _H	2A _H
ASC0 Transmit Buffer	S0TBIR	S0TBIE	S0TBINT	00'011C _H	47 _H
ASC0 Receive	S0RIR	S0RIE	S0RINT	00'00AC _H	2B _H
ASC0 Error	S0EIR	S0EIE	S0EINT	00'00B0 _H	2C _H
SSC Transmit	SCTIR	SCTIE	SCTINT	00'00B4 _H	2D _H
SSC Receive	SCRIR	SCRIE	SCRINT	00'00B8 _H	2E _H
SSC Error	SCEIR	SCEIE	SCEINT	00'00BC _H	2F _H
X-Peripheral Node 0	XP0IR	XP0IE	XP0INT	00'0100 _H	40 _H
X-Peripheral Node 1	XP1IR	XP1IE	XP1INT	00'0104 _H	41 _H
X-Peripheral Node 2	XP2IR	XP2IE	XP2INT	00'0108 _H	42 _H
X-Peripheral Node 3	XP3IR	XP3IE	XP3INT	00'010C _H	43 _H
Software Node	CC29IR	CC29IE	CC29INT	00'0110 _H	44 _H
Software Node	CC30IR	CC30IE	CC30INT	00'0114 _H	45 _H
Software Node	CC31IR	CC31IE	CC31INT	00'0118 _H	46 _H

The C165 also provides an excellent mechanism to identify and to process exceptions or error conditions that arise during run-time, so-called 'Hardware Traps'. Hardware traps cause immediate non-maskable system reaction which is similar to a standard interrupt service (branching to a dedicated vector table location). The occurrence of a hardware trap is additionally signified by an individual bit in the trap flag register (TFR). Except when another higher prioritized trap service is in progress, a hardware trap will interrupt any actual program execution. In turn, hardware trap services can normally not be interrupted by standard or PEC interrupts.

The following table shows all of the possible exceptions or error conditions that can arise during run-time:

Exception Condition	Trap Flag	Trap Vector	Vector Location	Trap Number	Trap Priority
Reset Functions:					
Hardware Reset		RESET	00'0000 _H	00 _H	III
Software Reset		RESET	00'0000 _H	00 _H	III
Watchdog Timer Overflow		RESET	00'0000 _H	00 _H	III
Class A Hardware Traps:					
Non-Maskable Interrupt	NMI	NMITRAP	00'0008 _H	02 _H	II
Stack Overflow	STKOF	STOTRAP	00'0010 _H	04 _H	II
Stack Underflow	STKUF	STUTRAP	00'0018 _H	06 _H	II
Class B Hardware Traps:					
Undefined Opcode	UNDOPC	BTRAP	00'0028 _H	0A _H	I
Protected Instruction Fault	PRTFLT	BTRAP	00'0028 _H	0A _H	I
Illegal Word Operand Access	ILLOPA	BTRAP	00'0028 _H	0A _H	I
Illegal Instruction Access	ILLINA	BTRAP	00'0028 _H	0A _H	I
Illegal External Bus Access	ILLBUS	BTRAP	00'0028 _H	0A _H	I
Reserved			[2C _H – 3C _H]	[0B _H – 0F _H]	
Software Traps			Any	Any	Current CPU Priority
TRAP Instruction			[00'0000 _H – 00'01FC _H] in steps of 4 _H	[00 _H – 7F _H]	

General Purpose Timer (GPT) Unit

The GPT unit represents a very flexible multifunctional timer/counter structure which may be used for many different time related tasks such as event timing and counting, pulse width and duty cycle measurements, pulse generation, or pulse multiplication.

The GPT unit incorporates five 16-bit timers which are organized in two separate modules, GPT1 and GPT2. Each timer in each module may operate independently in a number of different modes, or may be concatenated with another timer of the same module.

Each of the three timers T2, T3, T4 of module GPT1 can be configured individually for one of three basic modes of operation, which are Timer, Gated Timer, and Counter Mode. In Timer Mode, the input clock for a timer is derived from the CPU clock, divided by a programmable prescaler, while Counter Mode allows a timer to be clocked in reference to external events.

Pulse width or duty cycle measurement is supported in Gated Timer Mode, where the operation of a timer is controlled by the 'gate' level on an external input pin. For these purposes, each timer has one associated port pin (TxIN) which serves as gate or clock input. The maximum resolution of the timers in module GPT1 is 400 ns (@ 20-MHz CPU clock).

The count direction (up/down) for each timer is programmable by software or may additionally be altered dynamically by an external signal on a port pin (TxEUD) to facilitate e. g. position tracking.

Timers T3 and T4 have output toggle latches (TxOTL) which change their state on each timer overflow/underflow. The state of these latches may be output on port pins (TxOUT) e.g. for time out monitoring of external hardware components, or may be used internally to clock timers T2 and T4 for measuring long time periods with high resolution.

In addition to their basic operating modes, timers T2 and T4 may be configured as reload or capture registers for timer T3. When used as capture or reload registers, timers T2 and T4 are stopped. The contents of timer T3 is captured into T2 or T4 in response to a signal at their associated input pins (TxIN). Timer T3 is reloaded with the contents of T2 or T4 triggered either by an external signal or by a selectable state transition of its toggle latch T3OTL. When both T2 and T4 are configured to alternately reload T3 on opposite state transitions of T3OTL with the low and high times of a PWM signal, this signal can be constantly generated without software intervention.

With its maximum resolution of 200 ns (@ 20 MHz), the GPT2 module provides precise event control and time measurement. It includes two timers (T5, T6) and a capture/reload register (CAPREL). Both timers can be clocked with an input clock which is derived from the CPU clock via a programmable prescaler or with external signals. The count direction (up/down) for each timer is programmable by software or may additionally be altered dynamically by an external signal on a port pin (TxEUD). Concatenation of the timers is supported via the output toggle latch (T6OTL) of timer T6, which changes its state on each timer overflow/underflow.

The state of this latch may be used to clock timer T5, or it may be output on a port pin (T6OUT). The overflows/underflows of timer T6 can additionally be used to clock the CAPCOM timers T0 or T1, and to cause a reload from the CAPREL register. The CAPREL register may capture the contents of timer T5 based on an external signal transition on the corresponding port pin (CAPIN), and timer T5 may optionally be cleared after the capture procedure. This allows absolute time differences to be measured or pulse multiplication to be performed without software overhead.

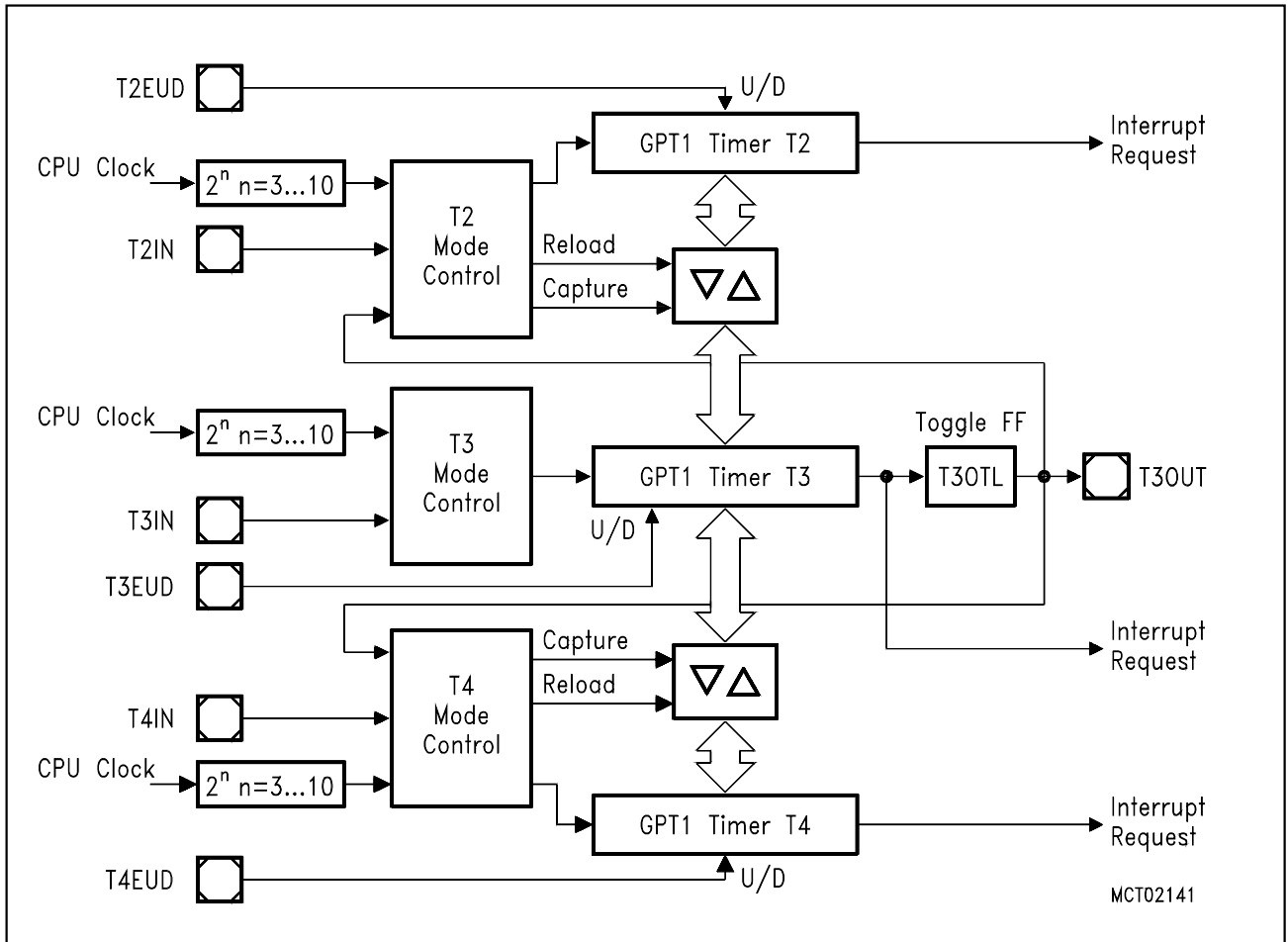

Figure 6
Block Diagram of GPT1

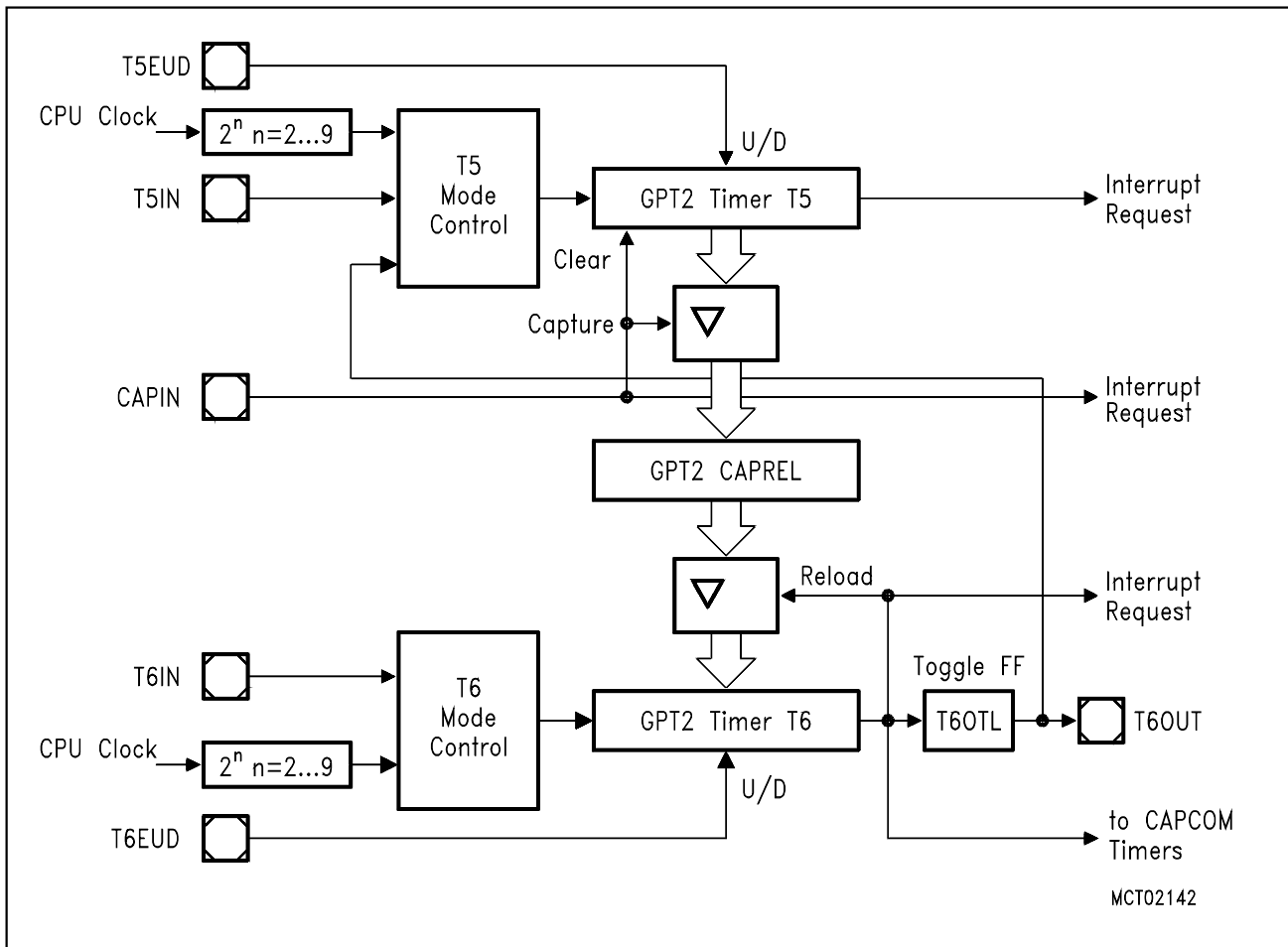

Figure 7
Block Diagram of GPT2

Parallel Ports

The C165 provides up to 77 I/O lines which are organized into six input/output ports and one input port. All port lines are bit-addressable, and all input/output lines are individually (bit-wise) programmable as inputs or outputs via direction registers. The I/O ports are true bidirectional ports which are switched to high impedance state when configured as inputs. The output drivers of three I/O ports can be configured (pin by pin) for push/pull operation or open-drain operation via control registers. During the internal reset, all port pins are configured as inputs.

All port lines have programmable alternate input or output functions associated with them. PORT0 and PORT1 may be used as address and data lines when accessing external memory, while Port 4 outputs the additional segment address bits A23/19/17...A16 in systems where segmentation is enabled to access more than 64 KBytes of memory. Port 6 provides optional bus arbitration signals (\overline{BREQ} , \overline{HLDA} , \overline{HOLD}) and chip select signals. Port 3 includes alternate functions of timers, serial interfaces, the optional bus control signal \overline{BHE} and the system clock output (CLKOUT). Port 5 is used for timer control signals. All port lines that are not used for these alternate functions may be used as general purpose I/O lines.

Serial Channels

Serial communication with other microcontrollers, processors, terminals or external peripheral components is provided by two serial interfaces with different functionality, an Asynchronous/Synchronous Serial Channel (ASC0) and a High-Speed Synchronous Serial Channel (SSC).

They are upward compatible with the serial ports of the Siemens SAB 8051x microcontroller family and support full-duplex asynchronous communication up to 625 KBaud and half-duplex synchronous communication up to 5 Mbaud (2.5 Mbaud on the ASC0) @ 20-MHz system clock.

Two dedicated baud rate generators allow to set up all standard baud rates without oscillator tuning. For transmission, reception, and erroneous reception 3 separate interrupt vectors are provided for each serial channel.

In asynchronous mode, 8- or 9-bit data frames are transmitted or received, preceded by a start bit and terminated by one or two stop bits. For multiprocessor communication, a mechanism to distinguish address from data bytes has been included (8-bit data + wake up bit mode).

In synchronous mode, the ASC0 transmits or receives bytes (8 bits) synchronously to a shift clock which is generated by the ASC0. The SSC transmits or receives characters of 2...16 bits length synchronously to a shift clock which can be generated by the SSC (master mode) or by an external master (slave mode). The SSC can start shifting with the LSB or with the MSB, while the ASC0 always shifts the LSB first.

A loop back option is available for testing purposes.

A number of optional hardware error detection capabilities has been included to increase the reliability of data transfers. A parity bit can automatically be generated on transmission or be checked on reception. Framing error detection allows to recognize data frames with missing stop bits. An overrun error will be generated, if the last character received has not been read out of the receive buffer register at the time the reception of a new character is complete.

Watchdog Timer

The Watchdog Timer represents one of the fail-safe mechanisms which have been implemented to prevent the controller from malfunctioning for longer periods of time.

The Watchdog Timer is always enabled after a reset of the chip, and can only be disabled in the time interval until the EINIT (end of initialization) instruction has been executed. Thus, the chip's start-up procedure is always monitored. The software has to be designed to service the Watchdog Timer before it overflows. If, due to hardware or software related failures, the software fails to do so, the Watchdog Timer overflows and generates an internal hardware reset and pulls the RSTOUT pin low in order to allow external hardware components to be reset.

The Watchdog Timer is a 16-bit timer, clocked with the system clock divided either by 2 or by 128. The high byte of the Watchdog Timer register can be set to a prespecified reload value (stored in WDTREL) in order to allow further variation of the monitored time interval. Each time it is serviced by the application software, the high byte of the Watchdog Timer is reloaded. Thus, time intervals between 25 μ s and 420 ms can be monitored (@ 20 MHz). The default Watchdog Timer interval after reset is 6.55 ms (@ 20 MHz).

Instruction Set Summary

The table below lists the instructions of the C165 in a condensed way.

The various addressing modes that can be used with a specific instruction, the operation of the instructions, parameters for conditional execution of instructions, and the opcodes for each instruction can be found in the “**C16x Family Instruction Set Manual**”.

This document also provides a detailed description of each instruction.

Instruction Set Summary

Mnemonic	Description	Bytes
ADD(B)	Add word (byte) operands	2 / 4
ADDC(B)	Add word (byte) operands with Carry	2 / 4
SUB(B)	Subtract word (byte) operands	2 / 4
SUBC(B)	Subtract word (byte) operands with Carry	2 / 4
MUL(U)	(Un)Signed multiply direct GPR by direct GPR (16-16-bit)	2
DIV(U)	(Un)Signed divide register MDL by direct GPR (16-/16-bit)	2
DIVL(U)	(Un)Signed long divide reg. MD by direct GPR (32-/16-bit)	2
CPL(B)	Complement direct word (byte) GPR	2
NEG(B)	Negate direct word (byte) GPR	2
AND(B)	Bitwise AND, (word/byte operands)	2 / 4
OR(B)	Bitwise OR, (word/byte operands)	2 / 4
XOR(B)	Bitwise XOR, (word/byte operands)	2 / 4
BCLR	Clear direct bit	2
BSET	Set direct bit	2
BMOV(N)	Move (negated) direct bit to direct bit	4
BAND, BOR, BXOR	AND/OR/XOR direct bit with direct bit	4
BCMP	Compare direct bit to direct bit	4
BFLDH/L	Bitwise modify masked high/low byte of bit-addressable direct word memory with immediate data	4
CMP(B)	Compare word (byte) operands	2 / 4
CMPD1/2	Compare word data to GPR and decrement GPR by 1/2	2 / 4
CMPI1/2	Compare word data to GPR and increment GPR by 1/2	2 / 4
PRIOR	Determine number of shift cycles to normalize direct word GPR and store result in direct word GPR	2
SHL / SHR	Shift left/right direct word GPR	2
ROL / ROR	Rotate left/right direct word GPR	2
ASHR	Arithmetic (sign bit) shift right direct word GPR	2

Instruction Set Summary (cont'd)

Mnemonic	Description	Bytes
MOV(B)	Move word (byte) data	2 / 4
MOVBS	Move byte operand to word operand with sign extension	2 / 4
MOVBZ	Move byte operand to word operand. with zero extension	2 / 4
JMPA, JMPI, JMPR	Jump absolute/indirect/relative if condition is met	4
JMPS	Jump absolute to a code segment	4
J(N)B	Jump relative if direct bit is (not) set	4
JBC	Jump relative and clear bit if direct bit is set	4
JNBS	Jump relative and set bit if direct bit is not set	4
CALLA, CALLI, CALLR	Call absolute/indirect/relative subroutine if condition is met	4
CALLS	Call absolute subroutine in any code segment	4
PCALL	Push direct word register onto system stack and call absolute subroutine	4
TRAP	Call interrupt service routine via immediate trap number	2
PUSH, POP	Push/pop direct word register onto/from system stack	2
SCXT	Push direct word register onto system stack and update register with word operand	4
RET	Return from intra-segment subroutine	2
RETS	Return from inter-segment subroutine	2
RETP	Return from intra-segment subroutine and pop direct word register from system stack	2
RETI	Return from interrupt service subroutine	2
SRST	Software Reset	4
IDLE	Enter Idle Mode	4
PWRDN	Enter Power Down Mode (supposes $\overline{\text{NMI}}$ -pin being low)	4
SRVWDT	Service Watchdog Timer	4
DISWDT	Disable Watchdog Timer	4
EINIT	Signify End-of-Initialization on RSTOUT-pin	4
ATOMIC	Begin ATOMIC sequence	2
EXTR	Begin EXTENDED Register sequence	2
EXTP(R)	Begin EXTENDED Page (and Register) sequence	2 / 4
EXTS(R)	Begin EXTENDED Segment (and Register) sequence	2 / 4
NOP	Null operation	2

Special Function Registers Overview

The following table lists all SFRs which are implemented in the C165 in alphabetical order.

Bit-addressable SFRs are marked with the letter “b” in column “Name”. SFRs within the **Extended SFR-Space** (ESFRs) are marked with the letter “E” in column “Physical Address”.

An SFR can be specified via its individual mnemonic name. Depending on the selected addressing mode, an SFR can be accessed via its physical address (using the Data Page Pointers), or via its short 8-bit address (without using the Data Page Pointers).

Special Function Registers Overview

Name	Physical Address	8-Bit Address	Description	Reset Value
ADDRSEL1	FE18 _H	0C _H	Address Select Register 1	0000 _H
ADDRSEL2	FE1A _H	0D _H	Address Select Register 2	0000 _H
ADDRSEL3	FE1C _H	0E _H	Address Select Register 3	0000 _H
ADDRSEL4	FE1E _H	0F _H	Address Select Register 4	0000 _H
BUSCON0 b	FF0C _H	86 _H	Bus Configuration Register 0	0XX0 _H
BUSCON1 b	FF14 _H	8A _H	Bus Configuration Register 1	0000 _H
BUSCON2 b	FF16 _H	8B _H	Bus Configuration Register 2	0000 _H
BUSCON3 b	FF18 _H	8C _H	Bus Configuration Register 3	0000 _H
BUSCON4 b	FF1A _H	8D _H	Bus Configuration Register 4	0000 _H
CAPREL	FE4A _H	25 _H	GPT2 Capture/Reload Register	0000 _H
CC8IC b	FF88 _H	C4 _H	EX0IN Interrupt Control Register	0000 _H
CC9IC b	FF8A _H	C5 _H	EX1IN Interrupt Control Register	0000 _H
CC10IC b	FF8C _H	C6 _H	EX2IN Interrupt Control Register	0000 _H
CC11IC b	FF8E _H	C7 _H	EX3IN Interrupt Control Register	0000 _H
CC12IC b	FF90 _H	C8 _H	EX4IN Interrupt Control Register	0000 _H
CC13IC b	FF92 _H	C9 _H	EX5IN Interrupt Control Register	0000 _H
CC14IC b	FF94 _H	CA _H	EX6IN Interrupt Control Register	0000 _H
CC15IC b	FF96 _H	CB _H	EX7IN Interrupt Control Register	0000 _H
CC29IC b	F184 _H E	C2 _H	Software Node Interrupt Control Register	0000 _H
CC30IC b	F18C _H E	C6 _H	Software Node Interrupt Control Register	0000 _H
CC31IC b	F194 _H E	CA _H	Software Node Interrupt Control Register	0000 _H
CP	FE10 _H	08 _H	CPU Context Pointer Register	FC00 _H

Special Function Registers Overview (cont'd)

Name		Physical Address	8-Bit Address	Description	Reset Value
CRIC	b	FF6A _H	B5 _H	GPT2 CAPREL Interrupt Control Register	0000 _H
CSP		FE08 _H	04 _H	CPU Code Segment Pointer Register (read only)	0000 _H
DP0L	b	F100 _H	E 80 _H	P0L Direction Control Register	00 _H
DP0H	b	F102 _H	E 81 _H	P0H Direction Control Register	00 _H
DP1L	b	F104 _H	E 82 _H	P1L Direction Control Register	00 _H
DP1H	b	F106 _H	E 83 _H	P1H Direction Control Register	00 _H
DP2	b	FFC2 _H	E1 _H	Port 2 Direction Control Register	0000 _H
DP3	b	FFC6 _H	E3 _H	Port 3 Direction Control Register	0000 _H
DP4	b	FFCA _H	E5 _H	Port 4 Direction Control Register	00 _H
DP6	b	FFCE _H	E7 _H	Port 6 Direction Control Register	00 _H
DPP0		FE00 _H	00 _H	CPU Data Page Pointer 0 Register (10 bits)	0000 _H
DPP1		FE02 _H	01 _H	CPU Data Page Pointer 1 Register (10 bits)	0001 _H
DPP2		FE04 _H	02 _H	CPU Data Page Pointer 2 Register (10 bits)	0002 _H
DPP3		FE06 _H	03 _H	CPU Data Page Pointer 3 Register (10 bits)	0003 _H
EXICON	b	F1C0 _H	E E0 _H	External Interrupt Control Register	0000 _H
MDC	b	FF0E _H	87 _H	CPU Multiply Divide Control Register	0000 _H
MDH		FE0C _H	06 _H	CPU Multiply Divide Register – High Word	0000 _H
MDL		FE0E _H	07 _H	CPU Multiply Divide Register – Low Word	0000 _H
ODP2	b	F1C2 _H	E E1 _H	Port 2 Open Drain Control Register	0000 _H
ODP3	b	F1C6 _H	E E3 _H	Port 3 Open Drain Control Register	0000 _H
ODP6	b	F1CE _H	E E7 _H	Port 6 Open Drain Control Register	00 _H
ONES		FF1E _H	8F _H	Constant Value 1's Register (read only)	FFFF _H
P0L	b	FF00 _H	80 _H	Port 0 Low Register (Lower half of PORT0)	00 _H
P0H	b	FF02 _H	81 _H	Port 0 High Register (Upper half of PORT0)	00 _H
P1L	b	FF04 _H	82 _H	Port 1 Low Register (Lower half of PORT1)	00 _H
P1H	b	FF06 _H	83 _H	Port 1 High Register (Upper half of PORT1)	00 _H
P2	b	FFC0 _H	E0 _H	Port 2 Register	0000 _H
P3	b	FFC4 _H	E2 _H	Port 3 Register	0000 _H
P4	b	FFC8 _H	E4 _H	Port 4 Register (8 bits)	00 _H

Special Function Registers Overview (cont'd)

Name		Physical Address	8-Bit Address	Description	Reset Value
P5	b	FFA2 _H	D1 _H	Port 5 Register (read only)	XXXX _H
P6	b	FFCC _H	E6 _H	Port 6 Register (8 bits)	00 _H
PECC0		FEC0 _H	60 _H	PEC Channel 0 Control Register	0000 _H
PECC1		FEC2 _H	61 _H	PEC Channel 1 Control Register	0000 _H
PECC2		FEC4 _H	62 _H	PEC Channel 2 Control Register	0000 _H
PECC3		FEC6 _H	63 _H	PEC Channel 3 Control Register	0000 _H
PECC4		FEC8 _H	64 _H	PEC Channel 4 Control Register	0000 _H
PECC5		FECA _H	65 _H	PEC Channel 5 Control Register	0000 _H
PECC6		FECC _H	66 _H	PEC Channel 6 Control Register	0000 _H
PECC7		FECE _H	67 _H	PEC Channel 7 Control Register	0000 _H
PSW	b	FF10 _H	88 _H	CPU Program Status Word	0000 _H
RP0H	b	F108 _H	E 84 _H	System Startup Configuration Register (Rd. only)	XX _H
S0BG		FEB4 _H	5A _H	Serial Channel 0 Baud Rate Generator Reload Register	0000 _H
S0CON	b	FFB0 _H	D8 _H	Serial Channel 0 Control Register	0000 _H
S0EIC	b	FF70 _H	B8 _H	Serial Channel 0 Error Interrupt Control Register	0000 _H
S0RBUF		FEB2 _H	59 _H	Serial Channel 0 Receive Buffer Register (read only)	XX _H
S0RIC	b	FF6E _H	B7 _H	Serial Channel 0 Receive Interrupt Control Register	0000 _H
S0TBIC	b	F19C _H	E CE _H	Serial Channel 0 Transmit Buffer Interrupt Control Register	0000 _H
S0TBUF		FEB0 _H	58 _H	Serial Channel 0 Transmit Buffer Register (write only)	00 _H
S0TIC	b	FF6C _H	B6 _H	Serial Channel 0 Transmit Interrupt Control Register	0000 _H
SP		FE12 _H	09 _H	CPU System Stack Pointer Register	FC00 _H
SSCBR		F0B4 _H	E 5A _H	SSC Baudrate Register	0000 _H
SSCCON	b	FFB2 _H	D9 _H	SSC Control Register	0000 _H
SSCEIC	b	FF76 _H	BB _H	SSC Error Interrupt Control Register	0000 _H

Special Function Registers Overview (cont'd)

Name	Physical Address	8-Bit Address	Description	Reset Value
SSCRB	F0B2 _H E	59 _H	SSC Receive Buffer (read only)	XXXX _H
SSCRIC	b FF74 _H	BA _H	SSC Receive Interrupt Control Register	0000 _H
SSCTB	F0B0 _H E	58 _H	SSC Transmit Buffer (write only)	0000 _H
SSCTIC	b FF72 _H	B9 _H	SSC Transmit Interrupt Control Register	0000 _H
STKOV	FE14 _H	0A _H	CPU Stack Overflow Pointer Register	FA00 _H
STKUN	FE16 _H	0B _H	CPU Stack Underflow Pointer Register	FC00 _H
SYSCON	b FF12 _H	89 _H	CPU System Configuration Register	0xx0 _H *)
T2	FE40 _H	20 _H	GPT1 Timer 2 Register	0000 _H
T2CON	b FF40 _H	A0 _H	GPT1 Timer 2 Control Register	0000 _H
T2IC	b FF60 _H	B0 _H	GPT1 Timer 2 Interrupt Control Register	0000 _H
T3	FE42 _H	21 _H	GPT1 Timer 3 Register	0000 _H
T3CON	b FF42 _H	A1 _H	GPT1 Timer 3 Control Register	0000 _H
T3IC	b FF62 _H	B1 _H	GPT1 Timer 3 Interrupt Control Register	0000 _H
T4	FE44 _H	22 _H	GPT1 Timer 4 Register	0000 _H
T4CON	b FF44 _H	A2 _H	GPT1 Timer 4 Control Register	0000 _H
T4IC	b FF64 _H	B2 _H	GPT1 Timer 4 Interrupt Control Register	0000 _H
T5	FE46 _H	23 _H	GPT2 Timer 5 Register	0000 _H
T5CON	b FF46 _H	A3 _H	GPT2 Timer 5 Control Register	0000 _H
T5IC	b FF66 _H	B3 _H	GPT2 Timer 5 Interrupt Control Register	0000 _H
T6	FE48 _H	24 _H	GPT2 Timer 6 Register	0000 _H
T6CON	b FF48 _H	A4 _H	GPT2 Timer 6 Control Register	0000 _H
T6IC	b FF68 _H	B4 _H	GPT2 Timer 6 Interrupt Control Register	0000 _H
TFR	b FFAC _H	D6 _H	Trap Flag Register	0000 _H
WDT	FEAE _H	57 _H	Watchdog Timer Register (read only)	0000 _H
WDTCON	FFAE _H	D7 _H	Watchdog Timer Control Register	0000 _H
XP0IC	b F186 _H E	C3 _H	X-Peripheral 0 Interrupt Control Register	0000 _H
XP1IC	b F18E _H E	C7 _H	X-Peripheral 1 Interrupt Control Register	0000 _H
XP2IC	b F196 _H E	CB _H	X-Peripheral 2 Interrupt Control Register	0000 _H

Special Function Registers Overview (cont'd)

Name	Physical Address	8-Bit Address	Description	Reset Value
XP3IC	b F19E _H E	CF _H	X-Peripheral 3 Interrupt Control Register	0000 _H
ZEROS	b FF1C _H	8E _H	Constant Value 0's Register (read only)	0000 _H

*) The system configuration is selected during reset.

Note: The Interrupt Control Registers XPnIC are prepared to control interrupt requests from integrated X-Bus peripherals. Nodes, where no X-Peripherals are connected, may be used to generate software controlled interrupt requests by setting the respective XPnIR bit.

Absolute Maximum Ratings

Ambient temperature under bias (T_A):

SAB-C165-LM, SAB-C165-RM, SAB-C165-LF, SAB-C165-RF 0 to + 70 °C

SAF-C165-LM – 40 to + 85 °C

Storage temperature (T_{ST}) – 65 to + 150 °C

Voltage on V_{CC} pins with respect to ground (V_{SS}) –0.5 to + 6.5 V

Voltage on any pin with respect to ground (V_{SS}) – 0.5 to $V_{CC} + 0.5$ V

Input current on any pin during overload condition – 10 to + 10 mA

Absolute sum of all input currents during overload condition |100 mA|

Power dissipation 1.5 W

Note: Stresses above those listed under “Absolute Maximum Ratings” may cause permanent damage to the device. This is a stress rating only and functional operation of the device at these or any other conditions above those indicated in the operational sections of this specification is not implied. Exposure to absolute maximum rating conditions for extended periods may affect device reliability. During overload conditions ($V_{IN} > V_{CC}$ or $V_{IN} < V_{SS}$) the voltage on pins with respect to ground (V_{SS}) must not exceed the values defined by the Absolute Maximum Ratings.

Parameter Interpretation

The parameters listed in the following partly represent the characteristics of the C165 and partly its demands on the system. To aid in interpreting the parameters right, when evaluating them for a design, they are marked in column “Symbol”:

CC (Controller Characteristics):

The logic of the C165 will provide signals with the respective timing characteristics.

SR (System Requirement):

The external system must provide signals with the respective timing characteristics to the C165.

DC Characteristics

$V_{CC} = 5\text{ V} \pm 10\%$; $V_{SS} = 0\text{ V}$; $f_{CPU} = 20\text{ MHz}$; Reset active

$T_A = 0\text{ to }+70\text{ °C}$ for SAB-C165-LM, SAB-C165-RM, SAB-C165-LF, SAB-C165-RF

$T_A = -40\text{ to }+85\text{ °C}$ for SAF-C165-LM

Parameter	Symbol	Limit Values		Unit	Test Condition
		min.	max.		
Input low voltage	V_{IL} SR	– 0.5	$0.2 V_{CC}$ – 0.1	V	–
Input high voltage (all except \overline{RSTIN} and XTAL1)	V_{IH} SR	$0.2 V_{CC}$ + 0.9	$V_{CC} + 0.5$	V	–
Input high voltage \overline{RSTIN}	V_{IH1} SR	$0.6 V_{CC}$	$V_{CC} + 0.5$	V	–
Input high voltage XTAL1	V_{IH2} SR	$0.7 V_{CC}$	$V_{CC} + 0.5$	V	–

Parameter	Symbol	Limit Values		Unit	Test Condition
		min.	max.		
Output low voltage (PORT0, PORT1, Port 4, ALE, \overline{RD} , \overline{WR} , \overline{BHE} , CLKOUT, \overline{RSTOUT})	V_{OL} CC	–	0.45	V	$I_{OL} = 2.4 \text{ mA}$
Output low voltage (all other outputs)	V_{OL1} CC	–	0.45	V	$I_{OL1} = 1.6 \text{ mA}$
Output high voltage (PORT0, PORT1, Port 4, ALE, \overline{RD} , \overline{WR} , \overline{BHE} , CLKOUT, \overline{RSTOUT})	V_{OH} CC	$0.9 V_{CC}$ 2.4	–	V	$I_{OH} = -500 \mu\text{A}$ $I_{OH} = -2.4 \text{ mA}$
Output high voltage ¹⁾ (all other outputs)	V_{OH1} CC	$0.9 V_{CC}$ 2.4	–	V V	$I_{OH} = -250 \mu\text{A}$ $I_{OH} = -1.6 \text{ mA}$
Input leakage current (Port 5)	I_{OZ1} CC	–	± 200	nA	$0 \text{ V} < V_{IN} < V_{CC}$
Input leakage current (all other)	I_{OZ2} CC	–	± 500	nA	$0 \text{ V} < V_{IN} < V_{CC}$
\overline{RSTIN} pullup resistor	R_{RST} CC	50	150	k Ω	–
Read/Write inactive current ⁴⁾	I_{RWH} ²⁾	–	-40	μA	$V_{OUT} = 2.4 \text{ V}$
Read/Write active current ⁴⁾	I_{RWL} ³⁾	-500	–	μA	$V_{OUT} = V_{OLmax}$
ALE inactive current ⁴⁾	I_{ALEL} ²⁾	–	40	μA	$V_{OUT} = V_{OLmax}$
ALE active current ⁴⁾	I_{ALEH} ³⁾	500	–	μA	$V_{OUT} = 2.4 \text{ V}$
Port 6 inactive current ⁴⁾	I_{P6H} ²⁾	–	-40	μA	$V_{OUT} = 2.4 \text{ V}$
Port 6 active current ⁴⁾	I_{P6L} ³⁾	-500	–	μA	$V_{OUT} = V_{OL1max}$
PORT0 configuration current ⁴⁾	I_{P0H} ²⁾	–	-10	μA	$V_{IN} = V_{IHmin}$
	I_{P0L} ³⁾	-100	–	μA	$V_{IN} = V_{ILmax}$
XTAL1 input current	I_{IL} CC	–	± 20	μA	$0 \text{ V} < V_{IN} < V_{CC}$
Pin capacitance ⁵⁾ (digital inputs/outputs)	C_{IO} CC	–	10	pF	$f = 1 \text{ MHz}$ $T_A = 25 \text{ }^\circ\text{C}$
Power supply current	I_{CC}	–	$10 +$ $4 * f_{CPU}$	mA	$\overline{RSTIN} = V_{IL2}$ f_{CPU} in [MHz] ⁶⁾
Idle mode supply current	I_{ID}	–	$2 +$ $1.2 * f_{CPU}$	mA	$\overline{RSTIN} = V_{IH1}$ f_{CPU} in [MHz] ⁶⁾
Power-down mode supply current	I_{PD}	–	100	μA	$V_{CC} = 5.5 \text{ V}^{7)}$

Notes

- 1) This specification is not valid for outputs which are switched to open drain mode. In this case the respective output will float and the voltage results from the external circuitry.
- 2) The maximum current may be drawn while the respective signal line remains inactive.
- 3) The minimum current must be drawn in order to drive the respective signal line active.
- 4) This specification is only valid during Reset, or during Hold- or Adapt-mode. Port 6 pins are only affected, if they are used for \overline{CS} output and the open drain function is not enabled.
- 5) Not 100% tested, guaranteed by design characterization.
- 6) The supply current is a function of the operating frequency. This dependency is illustrated in the figure below. These parameters are tested at V_{CCmax} and 20 MHz CPU clock with all outputs disconnected and all inputs at V_{IL} or V_{IH} .
- 7) This parameter is tested including leakage currents. All inputs (including pins configured as inputs) at 0 V to 0.1 V or at $V_{CC} - 0.1$ V to V_{CC} , $V_{REF} = 0$ V, all outputs (including pins configured as outputs) disconnected.

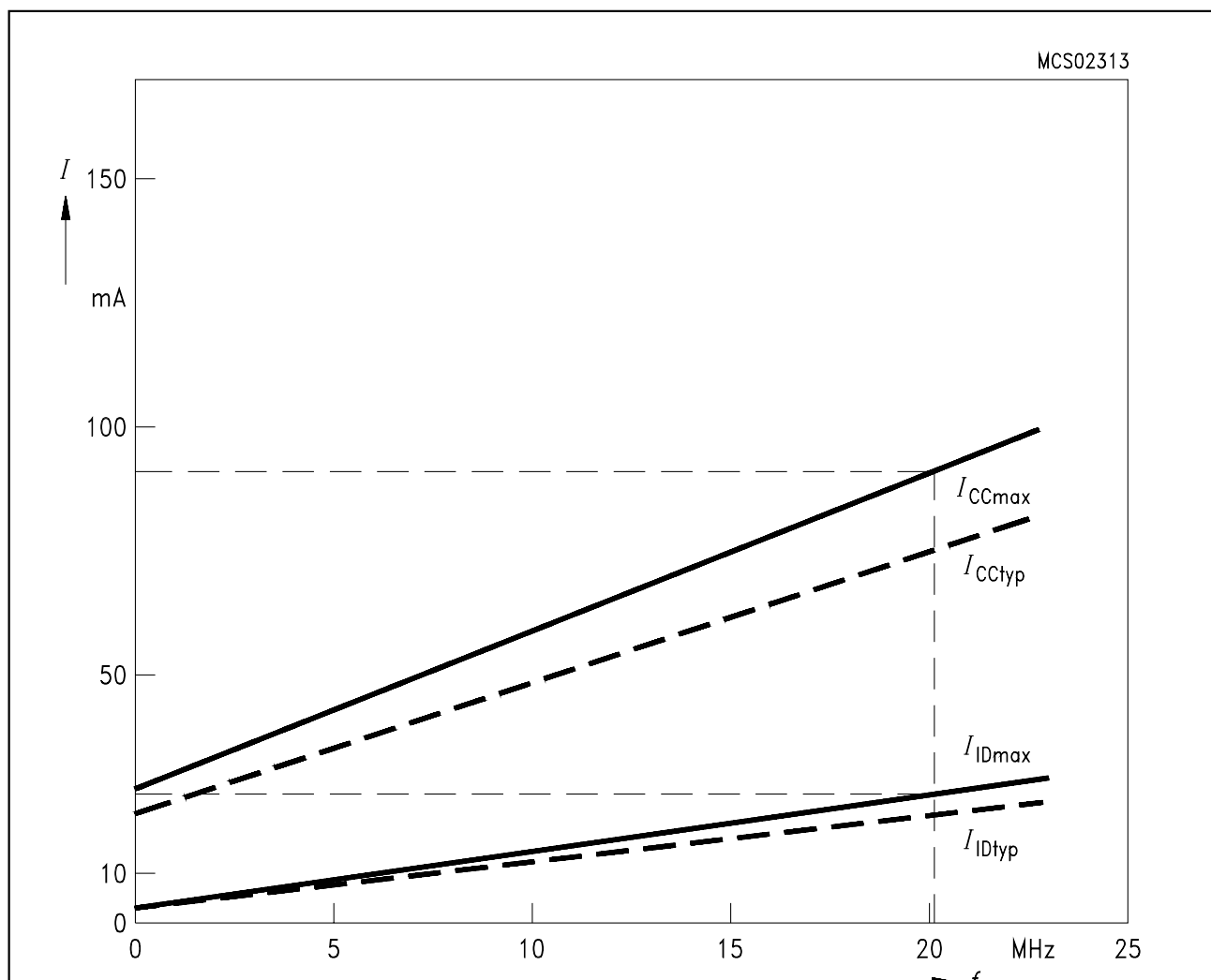

Figure 8
Supply/Idle Current as a Function of Operating Frequency

Testing Waveforms

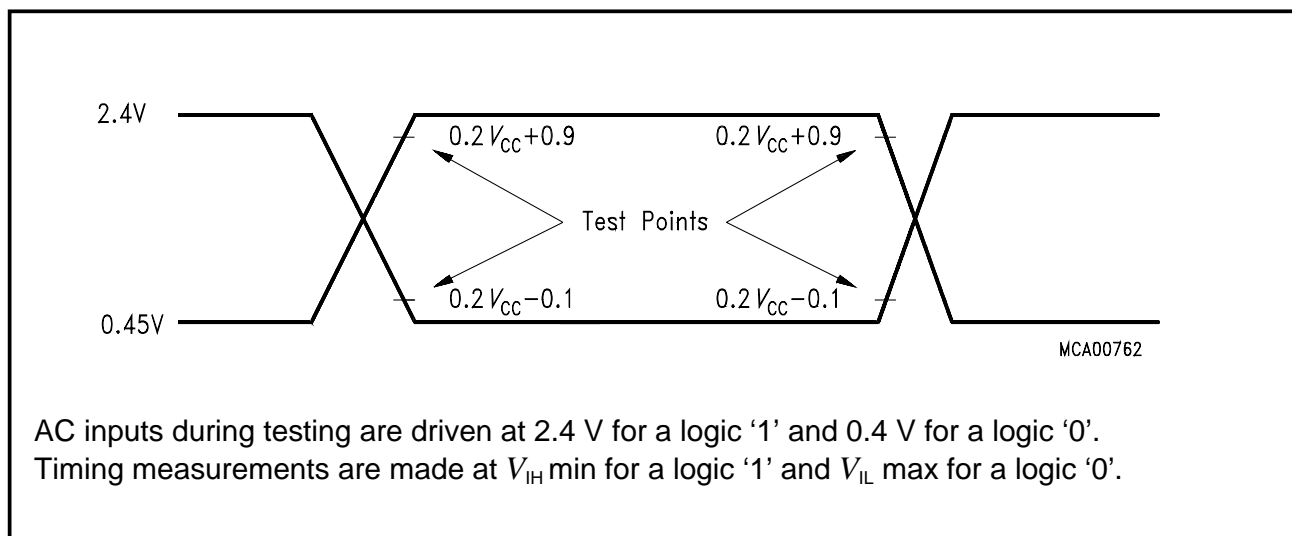

Figure 9
Input Output Waveforms

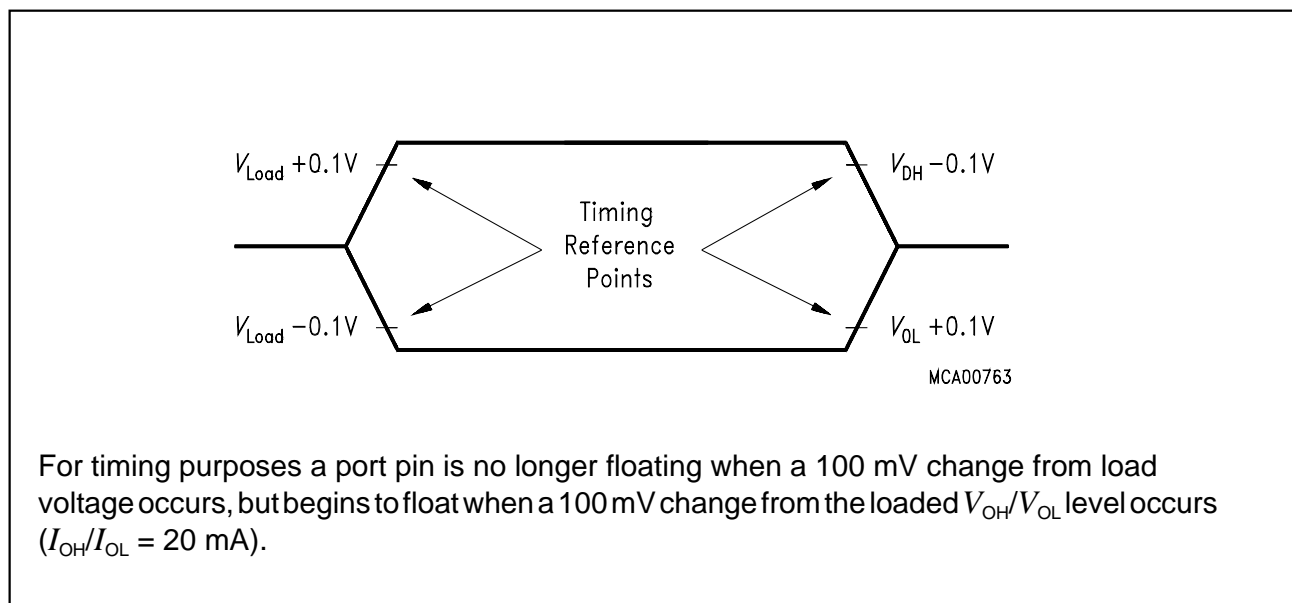

Figure 10
Float Waveforms

AC Characteristics

External Clock Drive XTAL1

$V_{CC} = 5\text{ V} \pm 10\%$; $V_{SS} = 0\text{ V}$

$T_A = 0\text{ to }+70\text{ }^\circ\text{C}$ for SAB-C165-LM, SAB-C165-RM, SAB-C165-LF, SAB-C165-RF

$T_A = -40\text{ to }+85\text{ }^\circ\text{C}$ for SAF-C165-LM

Parameter	Symbol	Max. CPU Clock = 20 MHz		Variable CPU Clock 1/2TCL = 1 to 20 MHz		Unit
		min.	max.	min.	max.	
Oscillator period	TCL SR	25	25	25	500	ns
High time	t_1 SR	6	–	6	–	ns
Low time	t_2 SR	6	–	6	–	ns
Rise time	t_3 SR	–	5	–	5	ns
Fall time	t_4 SR	–	5	–	5	ns

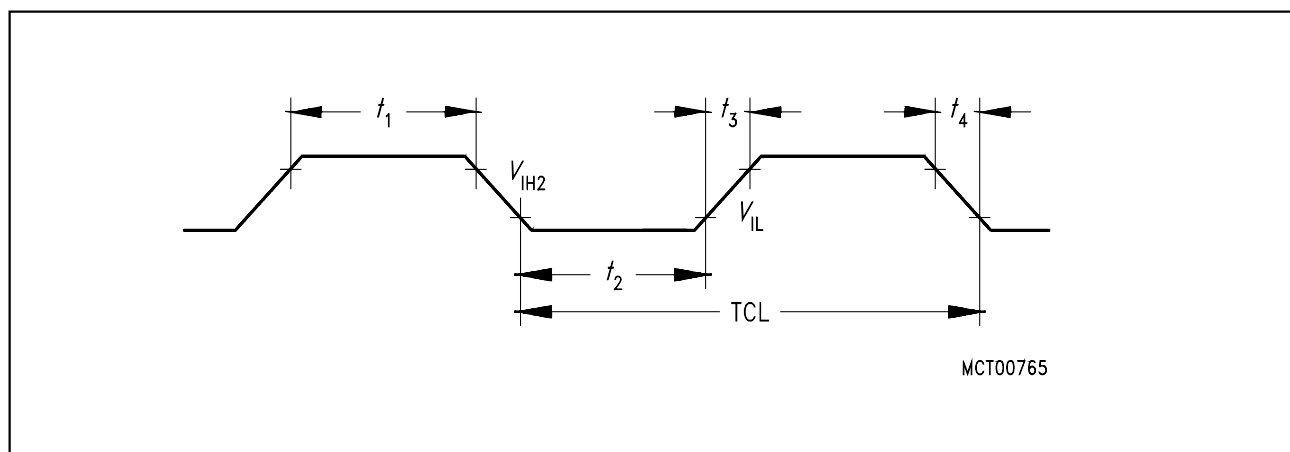

Figure 11
External Clock Drive XTAL1

Memory Cycle Variables

The timing tables below use three variables which are derived from the BUSCONx registers and represent the special characteristics of the programmed memory cycle. The following table describes, how these variables are to be computed.

Description	Symbol	Values
ALE Extension	t_A	$TCL * \langle ALECTL \rangle$
Memory Cycle Time Waitstates	t_C	$2TCL * (15 - \langle MCTC \rangle)$
Memory Tristate Time	t_F	$2TCL * (1 - \langle MTTC \rangle)$

AC Characteristics (cont'd)

Multiplexed Bus

$V_{CC} = 5\text{ V} \pm 10\%$; $V_{SS} = 0\text{ V}$

$T_A = 0\text{ to }+70\text{ }^\circ\text{C}$ for SAB-C165-LM, SAB-C165-RM, SAB-C165-LF, SAB-C165-RF

$T_A = -40\text{ to }+85\text{ }^\circ\text{C}$ for SAF-C165-LM

C_L (for PORT0, PORT1, Port 4, ALE, $\overline{\text{RD}}$, $\overline{\text{WR}}$, $\overline{\text{BHE}}$, CLKOUT) = 100 pF

C_L (for Port 6, $\overline{\text{CS}}$) = 100 pF

ALE cycle time = $6\text{ TCL} + 2t_A + t_C + t_F$ (150 ns at 20-MHz CPU clock without waitstates)

Parameter	Symbol	Max. CPU Clock = 20 MHz		Variable CPU Clock 1/2TCL = 1 to 20 MHz		Unit
		min.	max.	min.	max.	
ALE high time	t_5 CC	$15 + t_A$	–	$\text{TCL} - 10 + t_A$	–	ns
Address setup to ALE	t_6 CC	$10 + t_A$	–	$\text{TCL} - 15 + t_A$	–	ns
Address hold after ALE	t_7 CC	$15 + t_A$	–	$\text{TCL} - 10 + t_A$	–	ns
ALE falling edge to $\overline{\text{RD}}$, $\overline{\text{WR}}$ (with RW-delay)	t_8 CC	$15 + t_A$	–	$\text{TCL} - 10 + t_A$	–	ns
ALE falling edge to $\overline{\text{RD}}$, $\overline{\text{WR}}$ (no RW-delay)	t_9 CC	$-10 + t_A$	–	$-10 + t_A$	–	ns
Address float after $\overline{\text{RD}}$, $\overline{\text{WR}}$ (with RW-delay)	t_{10} CC	–	5	–	5	ns
Address float after $\overline{\text{RD}}$, $\overline{\text{WR}}$ (no RW-delay)	t_{11} CC	–	30	–	$\text{TCL} + 5$	ns
$\overline{\text{RD}}$, $\overline{\text{WR}}$ low time (with RW-delay)	t_{12} CC	$40 + t_C$	–	$2\text{TCL} - 10$ $+ t_C$	–	ns
$\overline{\text{RD}}$, $\overline{\text{WR}}$ low time (no RW-delay)	t_{13} CC	$65 + t_C$	–	$3\text{TCL} - 10$ $+ t_C$	–	ns
$\overline{\text{RD}}$ to valid data in (with RW-delay)	t_{14} SR	–	$30 + t_C$	–	$2\text{TCL} - 20$ $+ t_C$	ns
$\overline{\text{RD}}$ to valid data in (no RW-delay)	t_{15} SR	–	$55 + t_C$	–	$3\text{TCL} - 20$ $+ t_C$	ns
ALE low to valid data in	t_{16} SR	–	55 $+ t_A + t_C$	–	$3\text{TCL} - 20$ $+ t_A + t_C$	ns
Address to valid data in	t_{17} SR	–	70 $+ 2t_A + t_C$	–	$4\text{TCL} - 30$ $+ 2t_A + t_C$	ns
Data hold after $\overline{\text{RD}}$ rising edge	t_{18} SR	0	–	0	–	ns
Data float after $\overline{\text{RD}}$	t_{19} SR	–	$35 + t_F$	–	$2\text{TCL} - 15$ $+ t_F$	ns
Data valid to $\overline{\text{WR}}$	t_{22} SR	$35 + t_C$	–	$2\text{TCL} - 15$ $+ t_C$	–	ns

Parameter	Symbol	Max. CPU Clock = 20 MHz		Variable CPU Clock 1/2TCL = 1 to 20 MHz		Unit
		min.	max.	min.	max.	
Data hold after \overline{WR}	t_{23} CC	$35 + t_F$	–	$2TCL - 15 + t_F$	–	ns
ALE rising edge after \overline{RD} , \overline{WR}	t_{25} CC	$35 + t_F$	–	$2TCL - 15 + t_F$	–	ns
Address hold after \overline{RD} , \overline{WR}	t_{27} CC	$35 + t_F$	–	$2TCL - 15 + t_F$	–	ns
ALE falling edge to \overline{CS}	t_{38} CC	$-5 - t_A$	$10 - t_A$	$-5 - t_A$	$10 - t_A$	ns
\overline{CS} low to Valid Data In	t_{39} SR	–	$55 + t_C + 2t_A$	–	$3TCL - 20 + t_C + 2t_A$	ns
\overline{CS} hold after \overline{RD} , \overline{WR}	t_{40} CC	$60 + t_F$	–	$3TCL - 15 + t_F$	–	ns
ALE fall. edge to \overline{RdCS} , \overline{WrCS} (with RW delay)	t_{42} CC	$20 + t_A$	–	$TCL - 5 + t_A$	–	ns
ALE fall. edge to \overline{RdCS} , \overline{WrCS} (no RW delay)	t_{43} CC	$-5 + t_A$	–	$-5 + t_A$	–	ns
Address float after \overline{RdCS} , \overline{WrCS} (with RW delay)	t_{44} CC	–	0	–	0	ns
Address float after \overline{RdCS} , \overline{WrCS} (no RW delay)	t_{45} CC	–	25	–	TCL	ns
\overline{RdCS} to Valid Data In (with RW delay)	t_{46} SR	–	$25 + t_C$	–	$2TCL - 25 + t_C$	ns
\overline{RdCS} to Valid Data In (no RW delay)	t_{47} SR	–	$50 + t_C$	–	$3TCL - 25 + t_C$	ns
\overline{RdCS} , \overline{WrCS} Low Time (with RW delay)	t_{48} CC	$40 + t_C$	–	$2TCL - 10 + t_C$	–	ns
\overline{RdCS} , \overline{WrCS} Low Time (no RW delay)	t_{49} CC	$65 + t_C$	–	$3TCL - 10 + t_C$	–	ns
Data valid to \overline{WrCS}	t_{50} CC	$35 + t_C$	–	$2TCL - 15 + t_C$	–	ns
Data hold after \overline{RdCS}	t_{51} SR	0	–	0	–	ns
Data float after \overline{RdCS}	t_{52} SR	–	$30 + t_F$	–	$2TCL - 20 + t_F$	ns
Address hold after \overline{RdCS} , \overline{WrCS}	t_{54} CC	$30 + t_F$	–	$2TCL - 20 + t_F$	–	ns
Data hold after \overline{WrCS}	t_{56} CC	$30 + t_F$	–	$2TCL - 20 + t_F$	–	ns

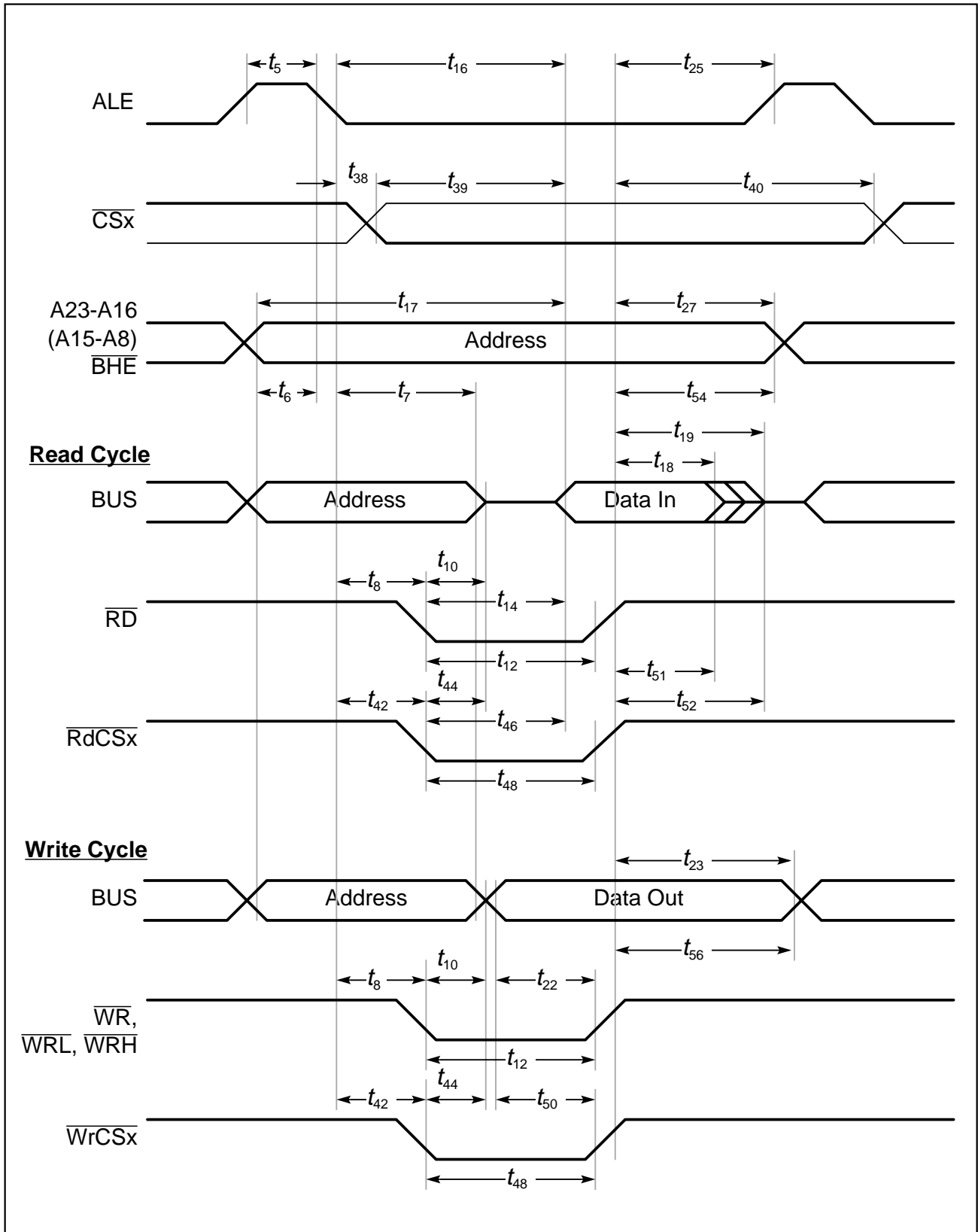

Figure 12-1
External Memory Cycle: Multiplexed Bus, With Read/Write Delay, Normal ALE

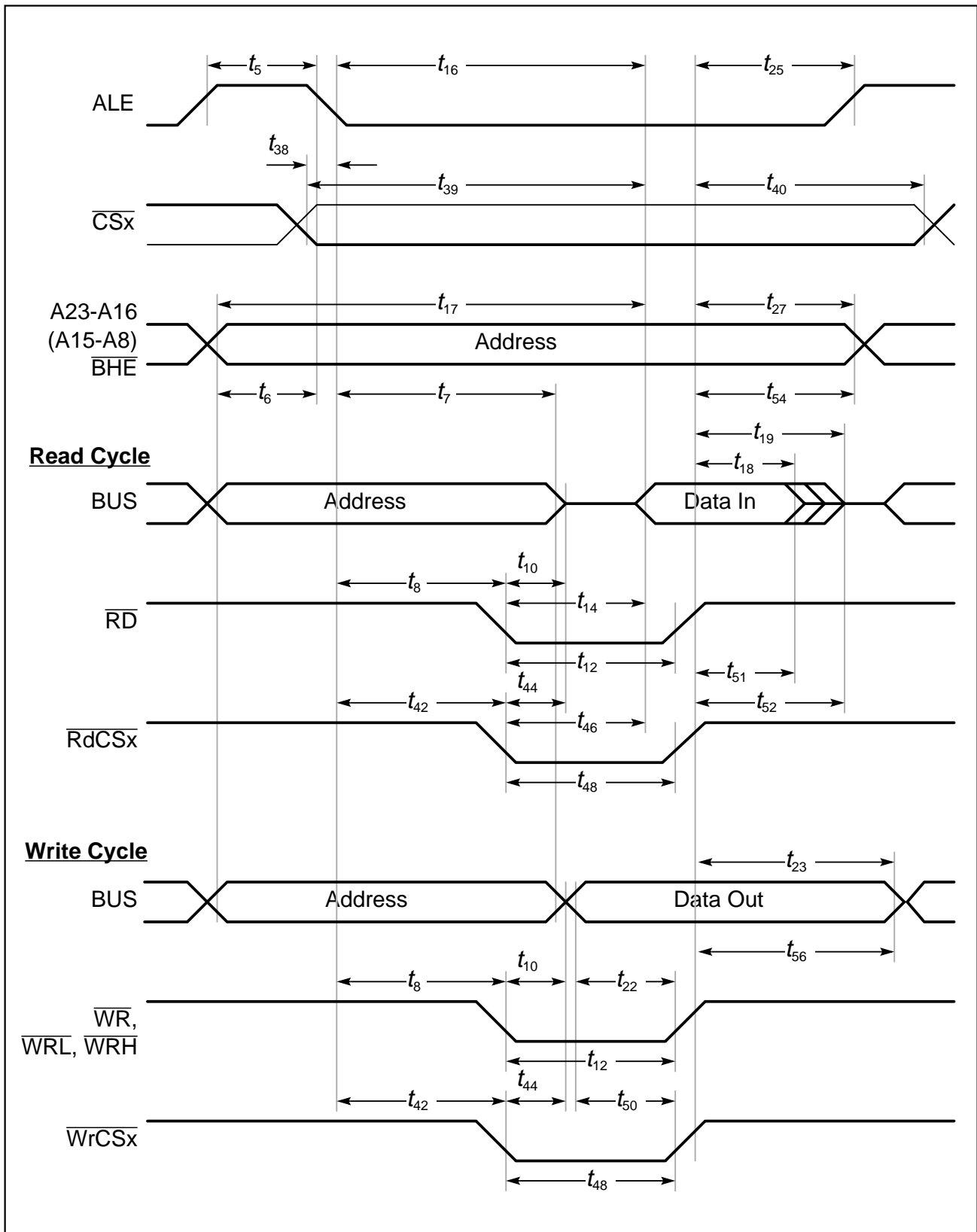

Figure 12-2
External Memory Cycle: Multiplexed Bus, With Read/Write Delay, Extended ALE

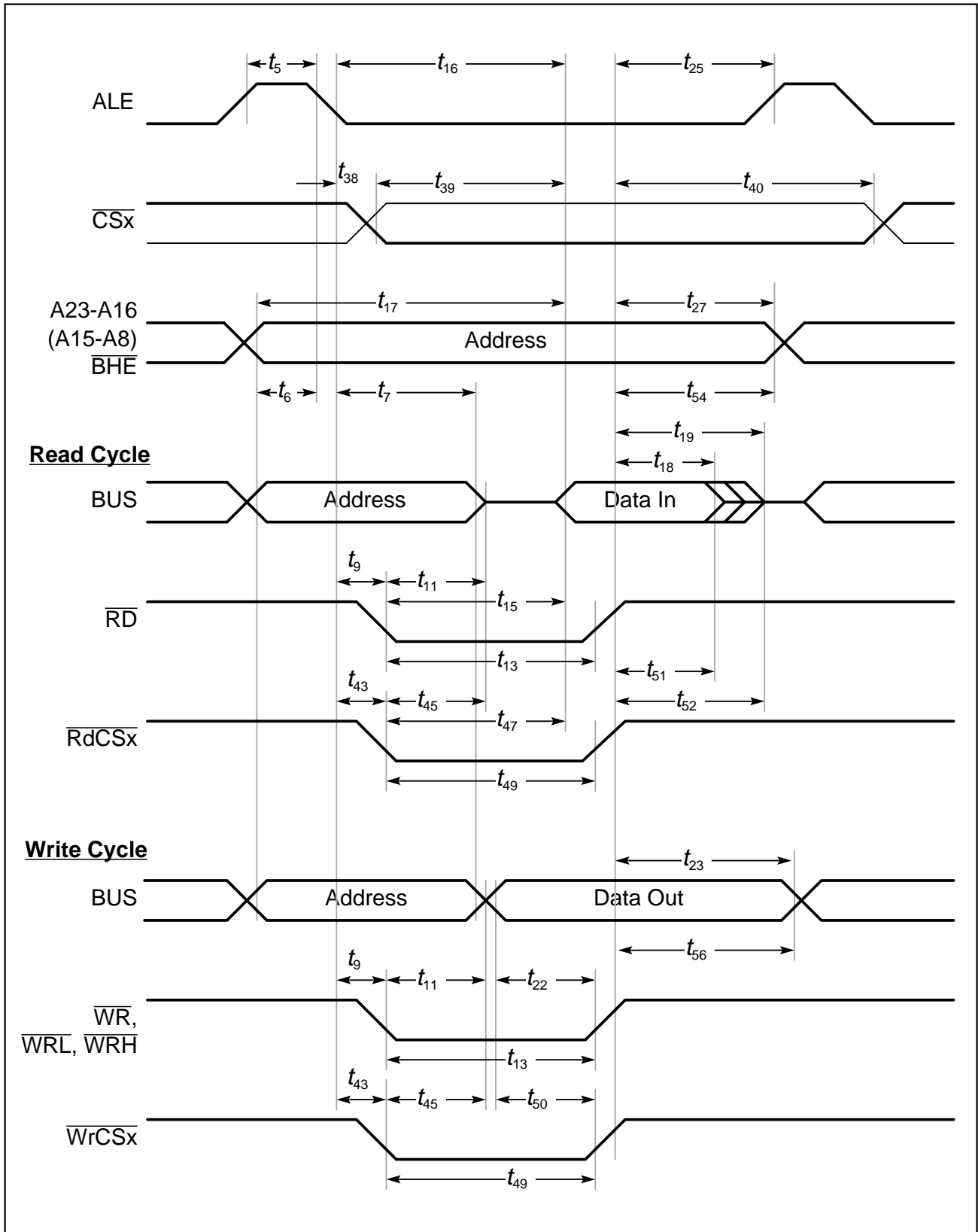

Figure 12-3
External Memory Cycle: Multiplexed Bus, No Read/Write Delay, Normal ALE

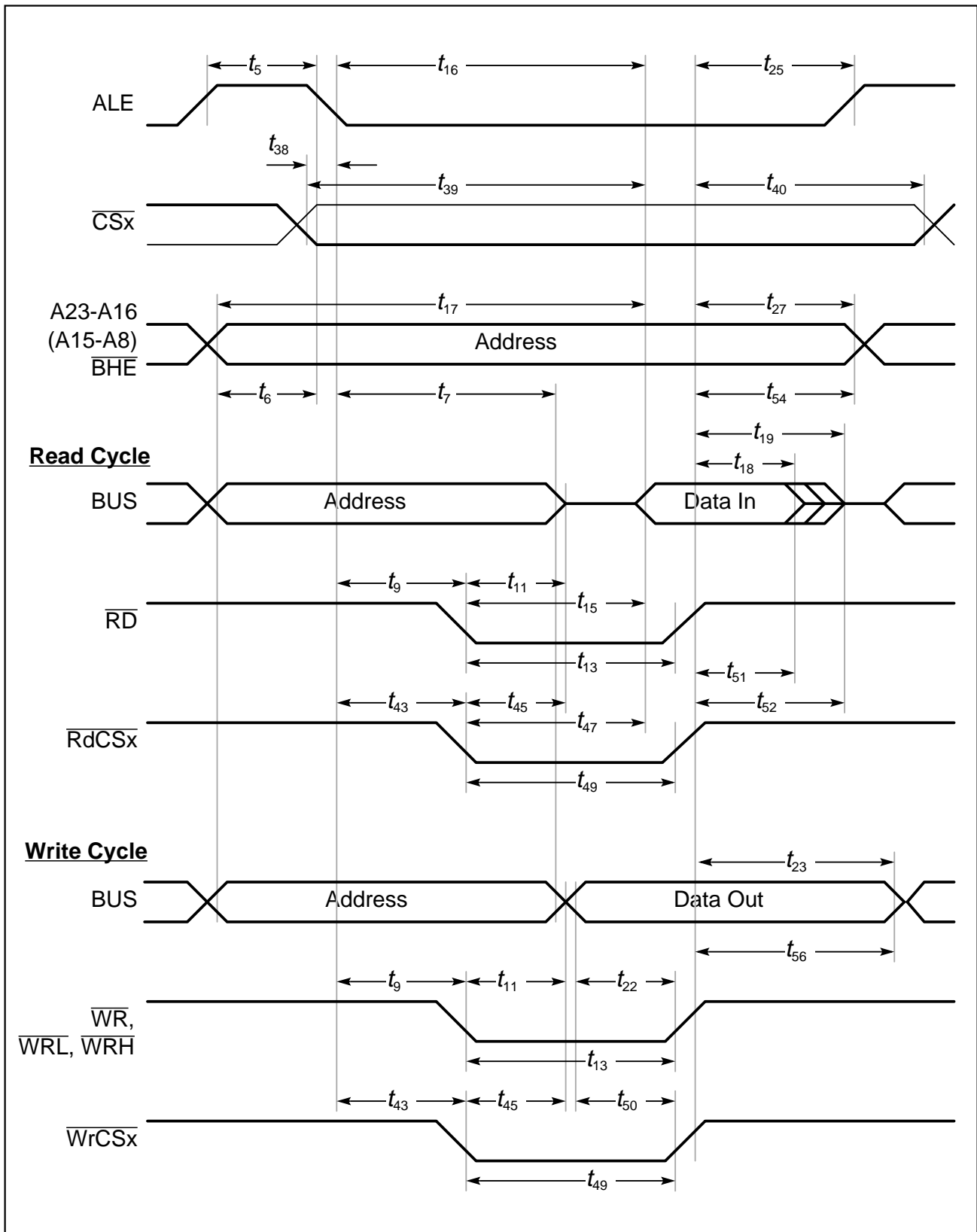

Figure 12-4
External Memory Cycle: Multiplexed Bus, No Read/Write Delay, Extended ALE

AC Characteristics (cont'd)

Demultiplexed Bus

$V_{CC} = 5\text{ V} \pm 10\%$; $V_{SS} = 0\text{ V}$

$T_A = 0\text{ to }+70\text{ }^\circ\text{C}$ for SAB-C165-LM, SAB-C165-RM, SAB-C165-LF, SAB-C165-RF

$T_A = -40\text{ to }+85\text{ }^\circ\text{C}$ for SAF-C165-LM

C_L (for PORT0, PORT1, Port 4, ALE, $\overline{\text{RD}}$, $\overline{\text{WR}}$, $\overline{\text{BHE}}$, CLKOUT) = 100 pF

C_L (for Port 6, $\overline{\text{CS}}$) = 100 pF

ALE cycle time = $4\text{ TCL} + 2t_A + t_C + t_F$ (100 ns at 20-MHz CPU clock without waitstates)

Parameter	Symbol	Max. CPU Clock = 20 MHz		Variable CPU Clock 1/2TCL = 1 to 20 MHz		Unit
		min.	max.	min.	max.	
ALE high time	t_5 CC	$15 + t_A$	–	$\text{TCL} - 10 + t_A$	–	ns
Address setup to ALE	t_6 CC	$10 + t_A$	–	$\text{TCL} - 15 + t_A$	–	ns
ALE falling edge to $\overline{\text{RD}}$, $\overline{\text{WR}}$ (with RW-delay)	t_8 CC	$15 + t_A$	–	$\text{TCL} - 10 + t_A$	–	ns
ALE falling edge to $\overline{\text{RD}}$, $\overline{\text{WR}}$ (no RW-delay)	t_9 CC	$-10 + t_A$	–	$-10 + t_A$	–	ns
$\overline{\text{RD}}$, $\overline{\text{WR}}$ low time (with RW-delay)	t_{12} CC	$40 + t_C$	–	$2\text{TCL} - 10 + t_C$	–	ns
$\overline{\text{RD}}$, $\overline{\text{WR}}$ low time (no RW-delay)	t_{13} CC	$65 + t_C$	–	$3\text{TCL} - 10 + t_C$	–	ns
$\overline{\text{RD}}$ to valid data in (with RW-delay)	t_{14} SR	–	$30 + t_C$	–	$2\text{TCL} - 20 + t_C$	ns
$\overline{\text{RD}}$ to valid data in (no RW-delay)	t_{15} SR	–	$55 + t_C$	–	$3\text{TCL} - 20 + t_C$	ns
ALE low to valid data in	t_{16} SR	–	$55 + t_A + t_C$	–	$3\text{TCL} - 20 + t_A + t_C$	ns
Address to valid data in	t_{17} SR	–	$70 + 2t_A + t_C$	–	$4\text{TCL} - 30 + 2t_A + t_C$	ns
Data hold after $\overline{\text{RD}}$ rising edge	t_{18} SR	0	–	0	–	ns
Data float after $\overline{\text{RD}}$ rising edge (with RW-delay)	t_{20} SR	–	$35 + t_F$	–	$2\text{TCL} - 15 + t_F$	ns
Data float after $\overline{\text{RD}}$ rising edge (no RW-delay)	t_{21} SR	–	$15 + t_F$	–	$\text{TCL} - 10 + t_F$	ns
Data valid to $\overline{\text{WR}}$	t_{22} CC	$35 + t_C$	–	$2\text{TCL} - 15 + t_C$	–	ns
Data hold after $\overline{\text{WR}}$	t_{24} CC	$15 + t_F$	–	$\text{TCL} - 10 + t_F$	–	ns
ALE rising edge after $\overline{\text{RD}}$, $\overline{\text{WR}}$	t_{26} CC	$-10 + t_F$	–	$-10 + t_F$	–	ns

Parameter	Symbol	Max. CPU Clock = 20 MHz		Variable CPU Clock 1/2TCL = 1 to 20 MHz		Unit
		min.	max.	min.	max.	
Address hold after \overline{RD} , \overline{WR}	t_{28} CC	$0 + t_F$	–	$0 + t_F$	–	ns
ALE falling edge to \overline{CS}	t_{38} CC	$-5 - t_A$	$10 - t_A$	$-5 - t_A$	$10 - t_A$	ns
\overline{CS} low to Valid Data In	t_{39} SR	–	$55 + t_C + 2t_A$	–	$3TCL - 20 + t_C + 2t_A$	ns
\overline{CS} hold after \overline{RD} , \overline{WR}	t_{41} CC	$10 + t_F$	–	$TCL - 15 + t_F$	–	ns
ALE falling edge to \overline{RdCS} , \overline{WrCS} (with RW-delay)	t_{42} CC	$20 + t_A$	–	$TCL - 5 + t_A$	–	ns
ALE falling edge to \overline{RdCS} , \overline{WrCS} (no RW-delay)	t_{43} CC	$-5 + t_A$	–	$-5 + t_A$	–	ns
\overline{RdCS} to Valid Data In (with RW-delay)	t_{46} SR	–	$25 + t_C$	–	$2TCL - 25 + t_C$	ns
\overline{RdCS} to Valid Data In (no RW-delay)	t_{47} SR	–	$50 + t_C$	–	$3TCL - 25 + t_C$	ns
\overline{RdCS} , \overline{WrCS} Low Time (with RW-delay)	t_{48} CC	$40 + t_C$	–	$2TCL - 10 + t_C$	–	ns
\overline{RdCS} , \overline{WrCS} Low Time (no RW-delay)	t_{49} CC	$65 + t_C$	–	$3TCL - 10 + t_C$	–	ns
Data valid to \overline{WrCS}	t_{50} CC	$35 + t_C$	–	$2TCL - 15 + t_C$	–	ns
Data hold after \overline{RdCS}	t_{51} SR	0	–	0	–	ns
Data float after \overline{RdCS} (with RW-delay)	t_{53} SR	–	$30 + t_F$	–	$2TCL - 20 + t_F$	ns
Data float after \overline{RdCS} (no RW-delay)	t_{68} SR	–	$5 + t_F$	–	$TCL - 20 + t_F$	ns
Address hold after \overline{RdCS} , \overline{WrCS}	t_{55} CC	$-5 + t_F$	–	$-5 + t_F$	–	ns
Data hold after \overline{WrCS}	t_{57} CC	$10 + t_F$	–	$TCL - 15 + t_F$	–	ns

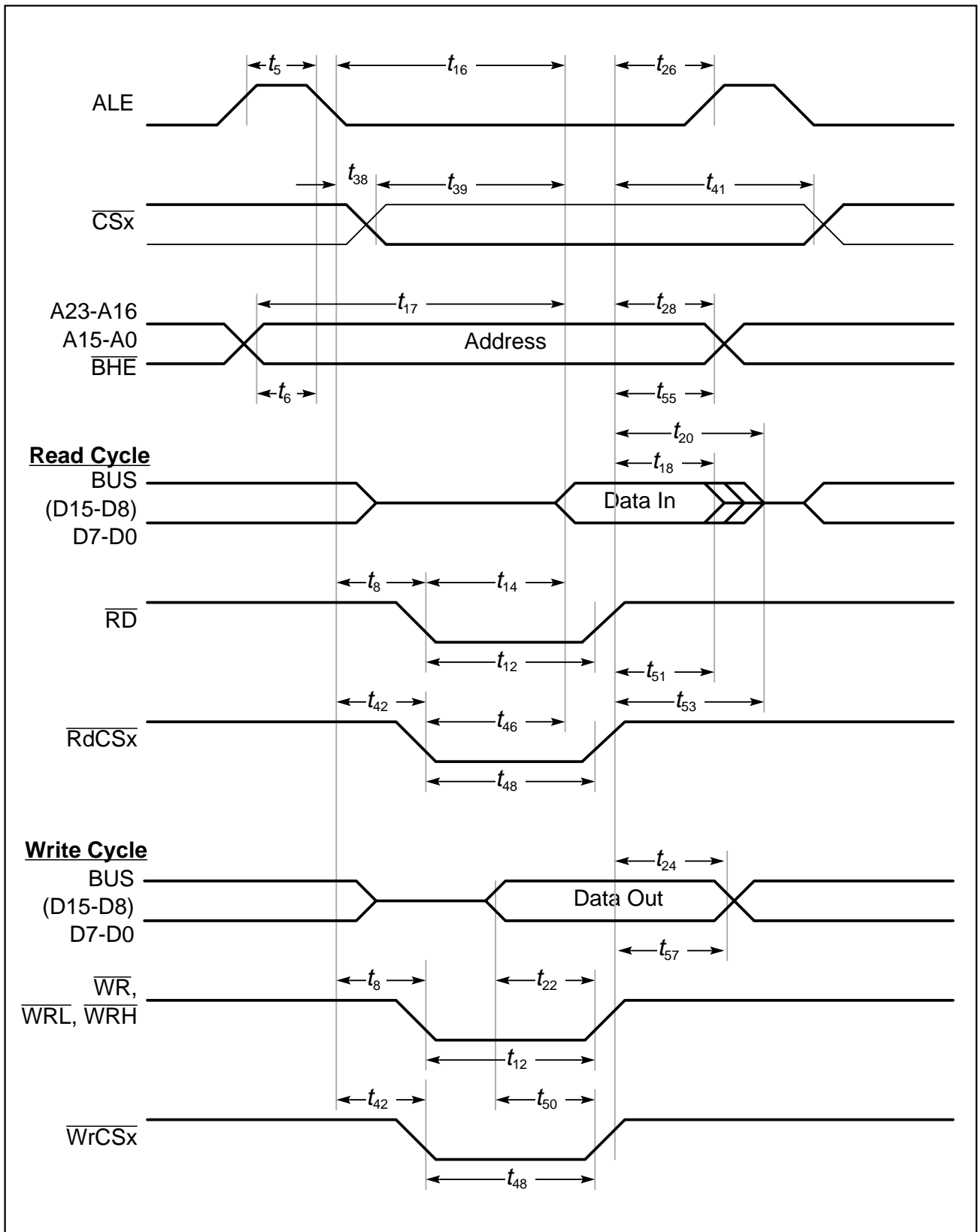

Figure 13-1
External Memory Cycle: Demultiplexed Bus, With Read/Write Delay, Normal ALE

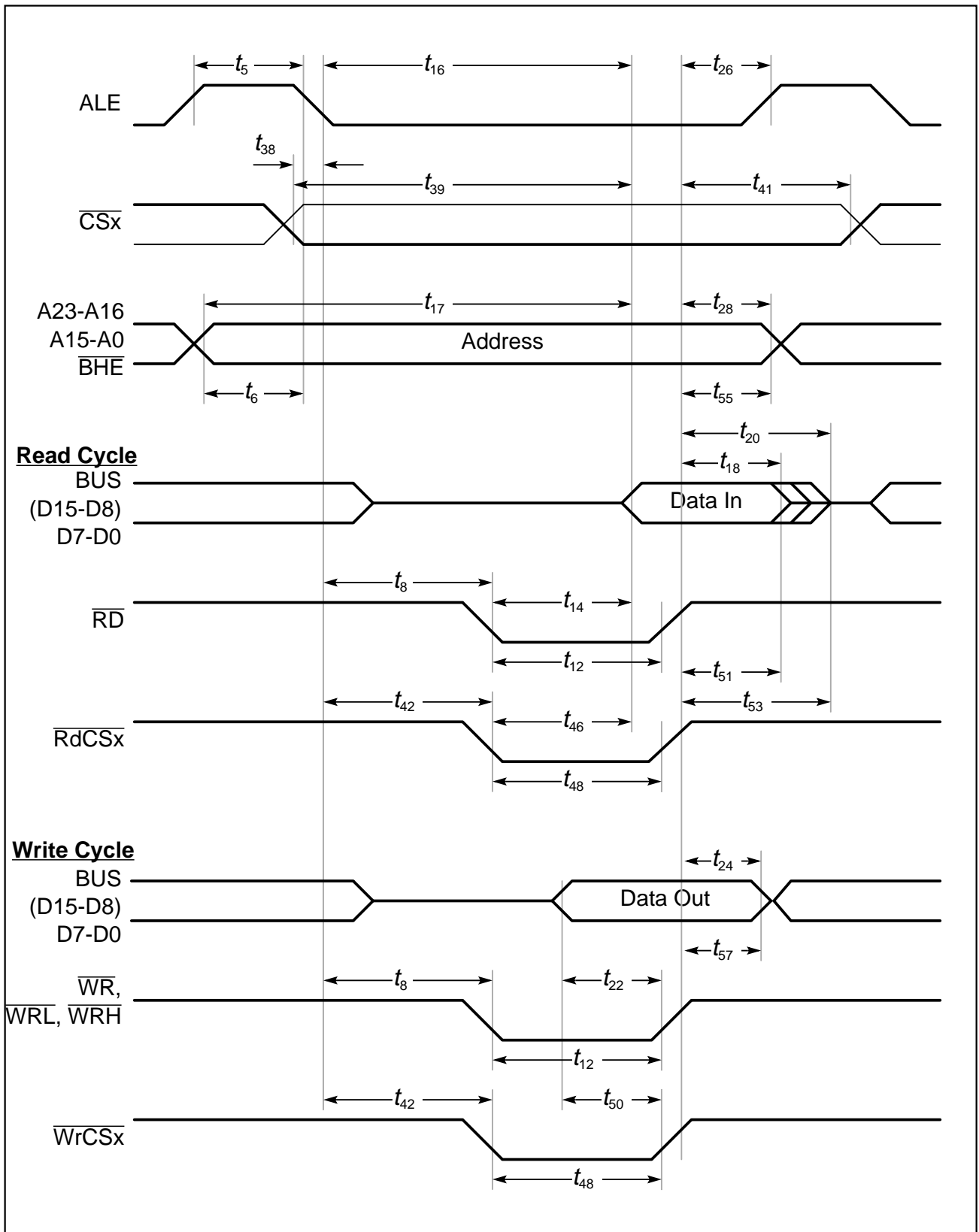

Figure 13-2
External Memory Cycle: Demultiplexed Bus, With Read/Write Delay, Extended ALE

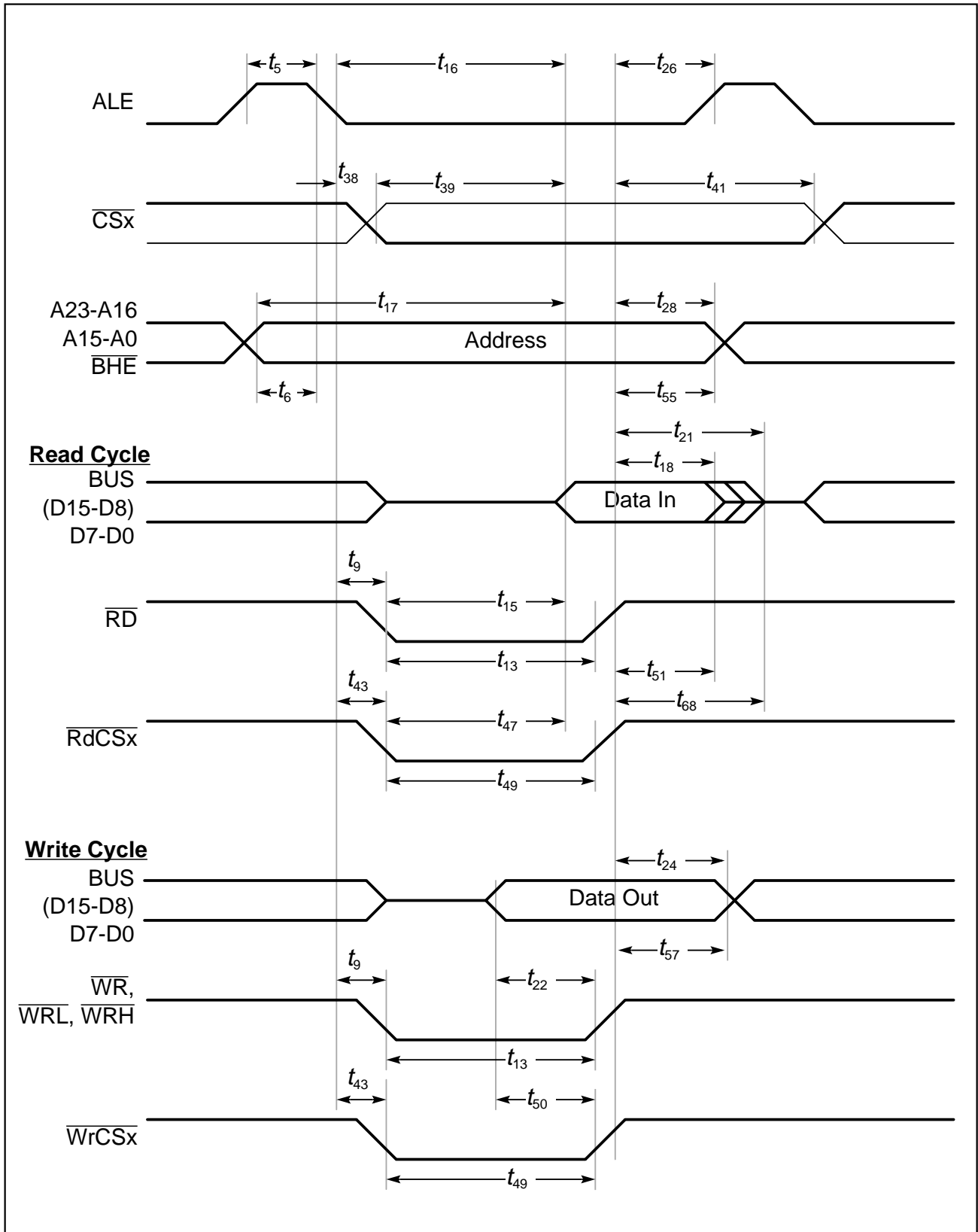

Figure 13-3
External Memory Cycle: Demultiplexed Bus, No Read/Write Delay, Normal ALE

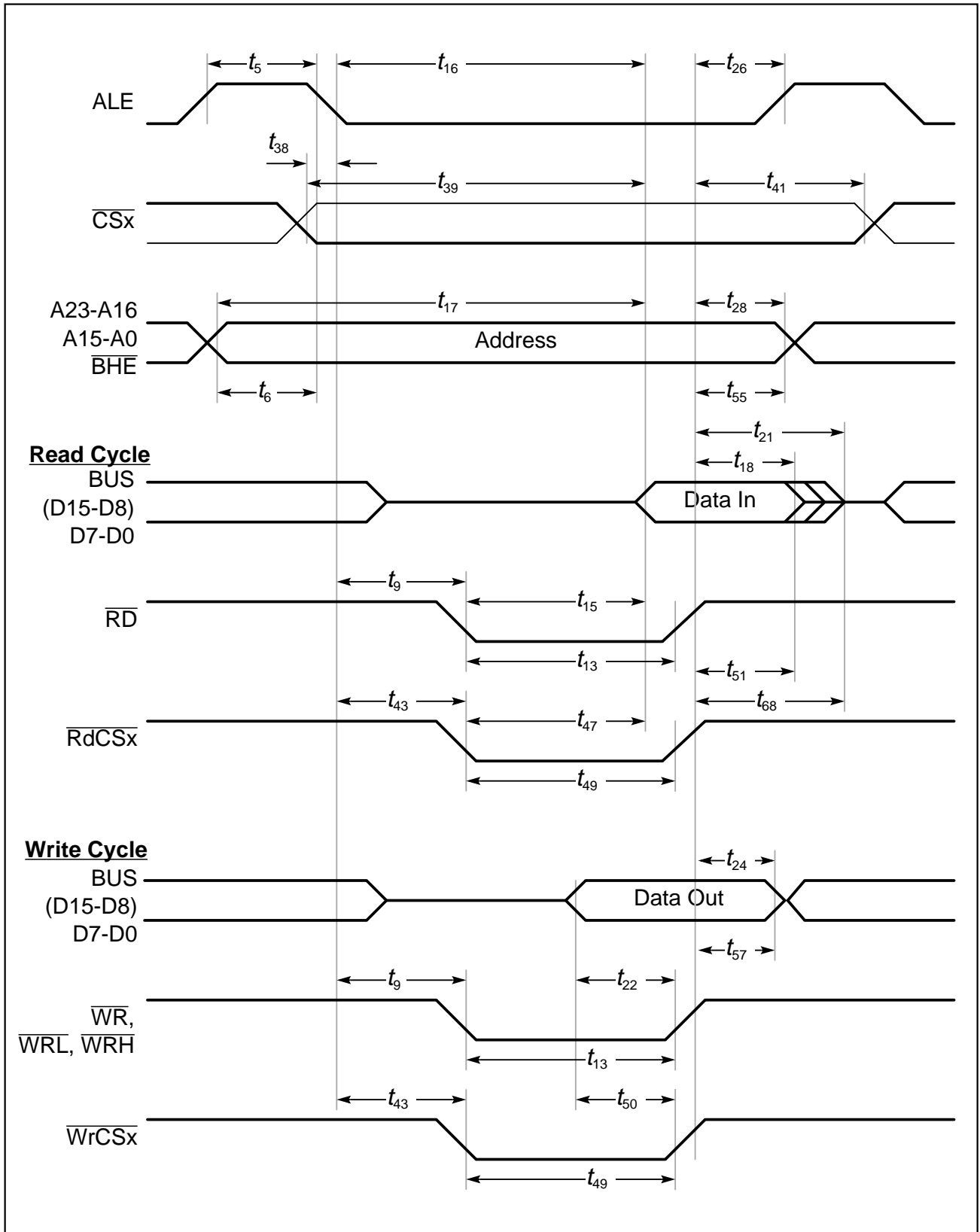

Figure 13-4
External Memory Cycle: Demultiplexed Bus, No Read/Write Delay, Extended ALE

AC Characteristics (cont'd)

CLKOUT and READY

$V_{CC} = 5\text{ V} \pm 10\%$; $V_{SS} = 0\text{ V}$

$T_A = 0\text{ to }+70\text{ }^\circ\text{C}$ for SAB-C165-LM, SAB-C165-RM, SAB-C165-LF, SAB-C165-RF

$T_A = -40\text{ to }+85\text{ }^\circ\text{C}$ for SAF-C165-LM

C_L (for PORT0, PORT1, Port 4, ALE, \overline{RD} , \overline{WR} , \overline{BHE} , CLKOUT) = 100 pF

C_L (for Port 6, \overline{CS}) = 100 pF

Parameter	Symbol	Max. CPU Clock = 20 MHz		Variable CPU Clock 1/2TCL = 1 to 20 MHz		Unit
		min.	max.	min.	max.	
CLKOUT cycle time	t_{29} CC	50	50	2TCL	2TCL	ns
CLKOUT high time	t_{30} CC	20	–	TCL – 5	–	ns
CLKOUT low time	t_{31} CC	15	–	TCL – 10	–	ns
CLKOUT rise time	t_{32} CC	–	5	–	5	ns
CLKOUT fall time	t_{33} CC	–	5	–	5	ns
CLKOUT rising edge to ALE falling edge	t_{34} CC	$0 + t_A$	$10 + t_A$	$0 + t_A$	$10 + t_A$	ns
Synchronous \overline{READY} setup time to CLKOUT	t_{35} SR	10	–	10	–	ns
Synchronous \overline{READY} hold time after CLKOUT	t_{36} SR	0	–	0	–	ns
Asynchronous \overline{READY} low time	t_{37} SR	65	–	2TCL + 15	–	ns
Asynchronous \overline{READY} setup time ¹⁾	t_{58} SR	15	–	15	–	ns
Asynchronous \overline{READY} hold time ¹⁾	t_{59} SR	0	–	0	–	ns
Async. \overline{READY} hold time after \overline{RD} , \overline{WR} high (Demultiplexed Bus) ²⁾	t_{60} SR	0	$0 + 2t_A + t_F$ ²⁾	0	TCL - 25 $+ 2t_A + t_F$ ²⁾	ns

Notes

- 1) These timings are given for test purposes only, in order to assure recognition at a specific clock edge.
- 2) Demultiplexed bus is the worst case. For multiplexed bus 2TCL are to be added to the maximum values. This adds even more time for deactivating READY.
The $2t_A$ refer to the next following bus cycle.

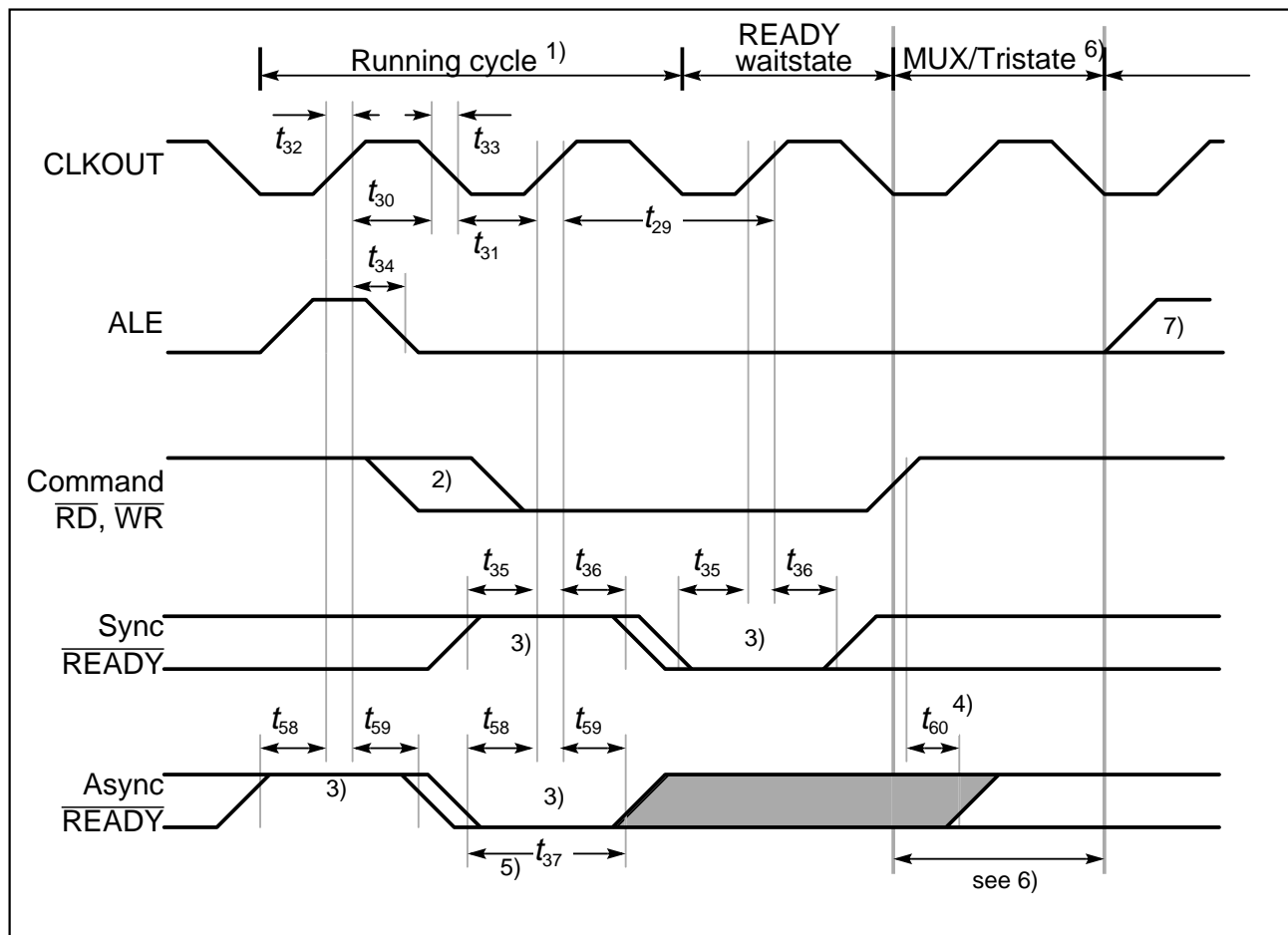

Figure 14
CLKOUT and $\overline{\text{READY}}$

Notes

- 1) Cycle as programmed, including MCTC waitstates (Example shows 0 MCTC WS).
- 2) The leading edge of the respective command depends on RW-delay.
- 3) $\overline{\text{READY}}$ sampled HIGH at this sampling point generates a READY controlled waitstate, $\overline{\text{READY}}$ sampled LOW at this sampling point terminates the currently running bus cycle.
- 4) $\overline{\text{READY}}$ may be deactivated in response to the trailing (rising) edge of the corresponding command ($\overline{\text{RD}}$ or $\overline{\text{WR}}$).
- 5) If the Asynchronous $\overline{\text{READY}}$ signal does not fulfill the indicated setup and hold times with respect to CLKOUT (e.g. because CLKOUT is not enabled), it must fulfill t_{37} in order to be safely synchronized. This is guaranteed, if $\overline{\text{READY}}$ is removed in response to the command (see Note 4).
- 6) Multiplexed bus modes have a MUX waitstate added after a bus cycle, and an additional MTTC waitstate may be inserted here.
For a multiplexed bus with MTTC waitstate this delay is 2 CLKOUT cycles, for a demultiplexed bus without MTTC waitstate this delay is zero.
- 7) The next external bus cycle may start here.

AC Characteristics (cont'd)

External Bus Arbitration

$V_{CC} = 5\text{ V} \pm 10\%$; $V_{SS} = 0\text{ V}$

$T_A = 0\text{ to }+70\text{ }^\circ\text{C}$ for SAB-C165-LM, SAB-C165-RM, SAB-C165-LF, SAB-C165-RF

$T_A = -40\text{ to }+85\text{ }^\circ\text{C}$ for SAF-C165-LM

C_L (for PORT0, PORT1, Port 4, ALE, $\overline{\text{RD}}$, $\overline{\text{WR}}$, $\overline{\text{BHE}}$, CLKOUT) = 100 pF

C_L (for Port 6, $\overline{\text{CS}}$) = 100 pF

Parameter	Symbol	Max. CPU Clock = 20 MHz		Variable CPU Clock 1/2TCL = 1 to 20 MHz		Unit
		min.	max.	min.	max.	
$\overline{\text{HOLD}}$ input setup time to CLKOUT	t_{61} SR	20	–	20	–	ns
CLKOUT to $\overline{\text{HLDA}}$ high or $\overline{\text{BREQ}}$ low delay	t_{62} CC	–	20	–	20	ns
CLKOUT to $\overline{\text{HLDA}}$ low or $\overline{\text{BREQ}}$ high delay	t_{63} CC	–	20	–	20	ns
$\overline{\text{CSx}}$ release	t_{64} CC	–	20	–	20	ns
$\overline{\text{CSx}}$ drive	t_{65} CC	-5	25	-5	25	ns
Other signals release	t_{66} CC	–	20	–	20	ns
Other signals drive	t_{67} CC	-5	25	-5	25	ns

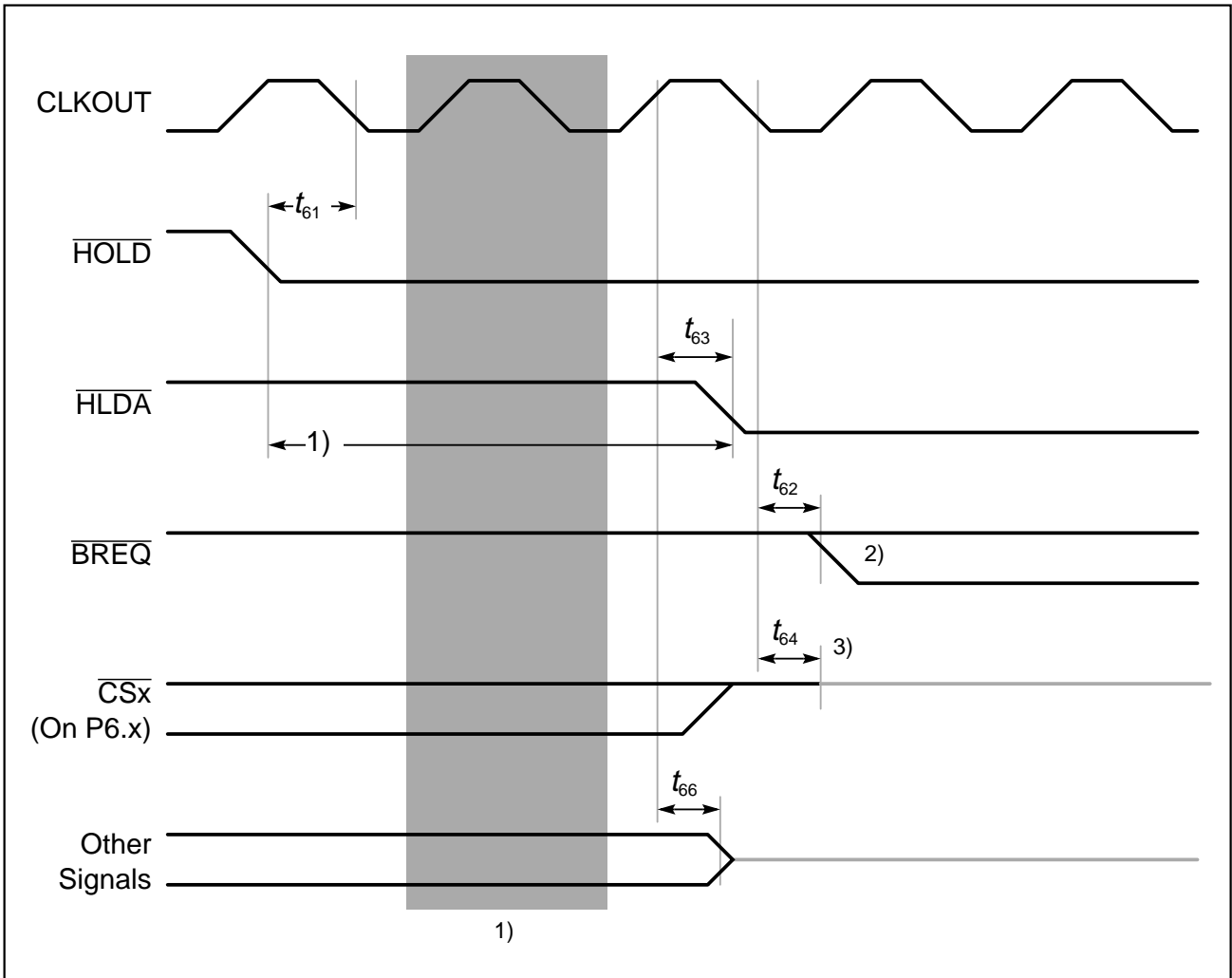

Figure 15
External Bus Arbitration, Releasing the Bus

Notes

- 1) The C165 will complete the currently running bus cycle before granting bus access.
- 2) This is the first possibility for $\overline{\text{BREQ}}$ to get active.
- 3) The $\overline{\text{CS}}$ outputs will be resistive high (pullup) after t_{64} .

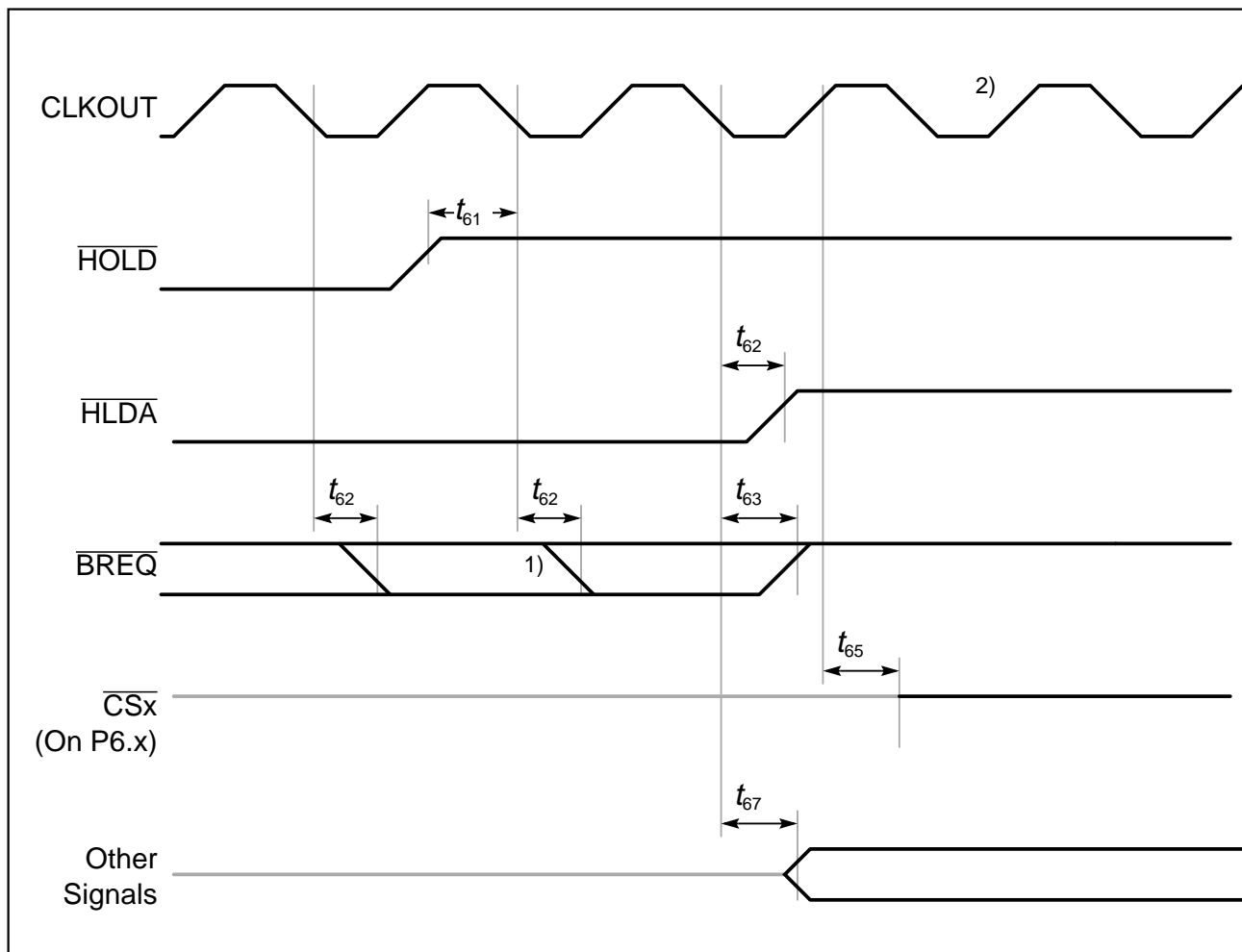

Figure 16
External Bus Arbitration, (Regaining the Bus)

Notes

- 1) This is the last chance for $\overline{\text{BREQ}}$ to trigger the indicated regain-sequence. Even if $\overline{\text{BREQ}}$ is activated earlier, the regain-sequence is initiated by $\overline{\text{HOLD}}$ going high. Please note that $\overline{\text{HOLD}}$ may also be deactivated without the C165 requesting the bus.
- 2) The next C165 driven bus cycle may start here.