



**Introduction**

DryLin® T slide guide rails were developed for applications in the automation and handling industries.

Rather than extreme precision the development objective was a robust linear guide system for reliable use in the widest range of different - environments. DryLin® T guide rails are shock resistant and have an extremely low weight design.

DryLin® T slide guide rails are exceptionally quiet in operation because there are no moving parts or metallic rollers.

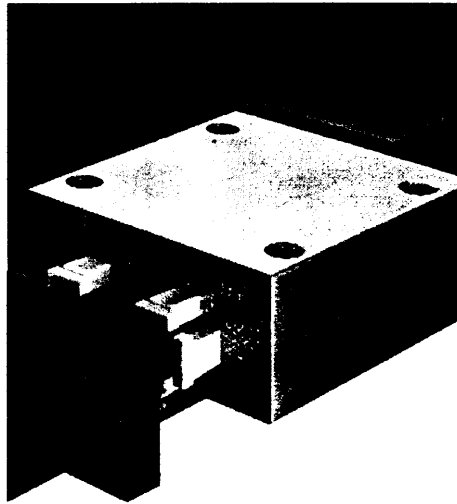

**Special Characteristics**

- No lubrication necessary
- adjustable clearance
- replaceable sliding inserts
- quiet operation
- resistant to dust, dirt and moisture
- corrosion resistant
- high static load rating in all directions
- low weight
- shock and vibration resistant
- excellent wear resistance

**Design**

DryLin® T slide guide rails consist of carriages mounted on the rail.

1. The rail, together with the basic body of the wagon, is made of aluminium Al Mg Si 0,5. The rail is hard anodised and the aluminium body of the slide is clear anodised.
2. The guide bearing consists of six opposing pairs of slide inserts made of iglidur J.
3. One side of each of the three guide bearings can be infinitely adjusted in height.
4. All steel parts are galvanised
5. The end covers are made of plastic

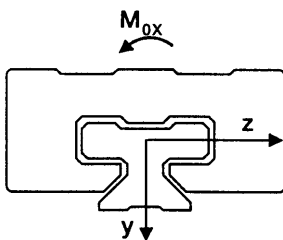

**Static load-bearing capacity**

Type	C <sub>0y</sub> [N]	C <sub>0(-y)</sub> [N]	C <sub>0z</sub> [N]	M <sub>0x</sub> [Nm]
15	4000	4000	2000	32
20	7400	7400	3700	85
25	10000	10000	5000	125
30	14000	14000	7000	200

- Very high accelerations possible
- extreme speeds can be attained quickly
- minimum effort for assembly
- replaceable slide inserts
- maintenance free
- corrosion resistant

igus® DryLin® T

igus GmbH P.O. Box 906123  
51127 Cologne / Germany

Telefon (02203) 9649-0  
Telefax (02203) 68950

Internet: <http://www.igus.de>

Mailbox: 0 22 03 - 66 61 54

email: [igus@compuserve.com](mailto:igus@compuserve.com)

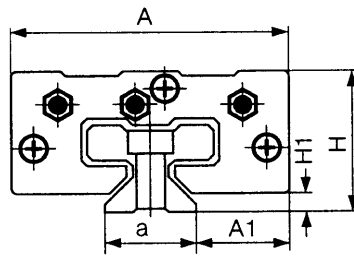
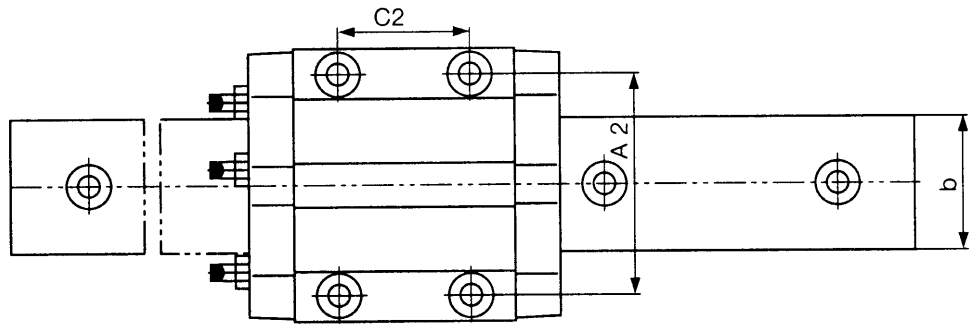
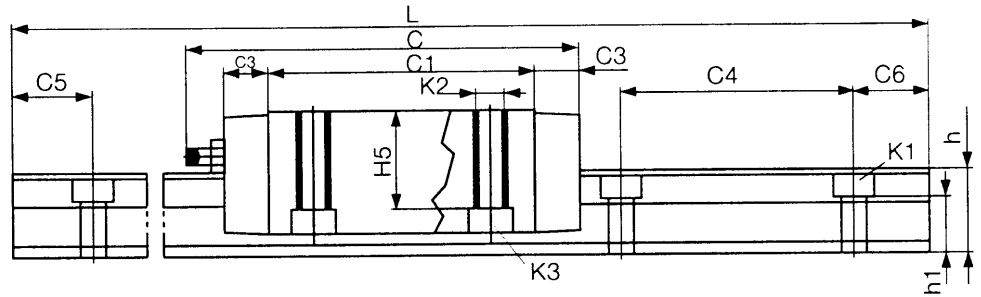

### Slide rail dimension table

Part. No.	weight kg/m	L max.	a -0,2	C4	C5 min.	C5 max.	C6 min.	C6 max.	h	h1	K1 for screw DIN 912	b	I <sub>y</sub> mm <sup>4</sup>	I <sub>z</sub> mm <sup>4</sup>
TS- 01-15	0,6	3960	15	60	20	49	20	49	15,5	10	M4	22	6440	4290
TS-01-20	1,0	3960	20	60	20	49	20	49	19	12,3	M5	31	22570	11520
TS-01-25	1,3	3960	23	60	20	49	20	49	21,5	13,8	M6	34	34700	19300
TS-01-30	1,9	3960	28	80	20	59	20	59	26	15,8	M8	40	70040	40780

### Slide carriage dimension table

Part. No.	weight kg	H ±0,35	A	C max.	A1 ±0,35	A2	C1	C2	C3	H1 ±0,35	H5	K2 thread	Nm max.	K3 for screw DIN 912
TW-01-15	0,11	24	47	72	16	38	50	30	9	4	16	M5	1,5	M4
TW-01-20	0,19	30	63	95	21,5	53	61	40	10	5	19,8	M6	2,5	M5
TW-01-25	0,29	36	70	105	23,5	57	68	45	11	5	24,8	M8	6	M6
TW-01-30	0,50	42	90	118	31	72	79	52	12	6,5	27	M10	15	M8

igus DryLin I

igus GmbH P.O. Box 906123

Telefon (02203) 9649-0

Internet: <http://www.igus.de>

51127 Cologne / Germany

Mailbox: 0 22 03 - 66 61 54

email: [igus@compuserve.com](mailto:igus@compuserve.com)



DryLin® T slide rail guides are delivered ready for installation. The slides are mounted on the rails and the tolerance is pre-adjusted.

As standard the rails of the DryLin® T guides are cut with a symmetrical bore pattern (C5=C6).

If you require another bore pattern please specify this in the order.

Please specify in the order how many slides per rail should be fitted. It is also necessary that you specify whether the guide is to be fitted as a fixed or floating bearing.

**Example:**

The requirement is a 550-mm-long, complete size 25 system, consisting of 2 guides, each fitted with 2 slides, and one side is to have a loose bearing:

**Order**

1 piece TK-01-25-2, length: 550m  
 + 1 piece TK-01-25-2, length: 550mm, LB

**Order number for individual guide carriage (Clearance only preset)**

- TW-01-15
- TW-01-20
- TW-01-25
- TW-01-30

Suffix for floating bearing: LB

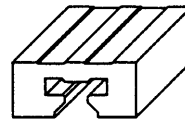

**Order number for guide rails**

- TS-01-15, length in mm
- TS-01-20, length in mm
- TS-01-25, length in mm
- TS-01-30, length in mm

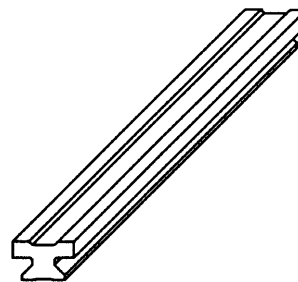

**Order number for pre-mounted DryLin® T slide rail guides (Assembled and clearance set)**

- TK-01-15 - specification on number of wagons, length in mm
- TK-01-20 - specification on number of wagons, length in mm
- TK-01-25 - specification on number of wagons, length in mm
- TK-01-30 - specification on number of wagons, length in mm

Suffix for floating bearing: LB

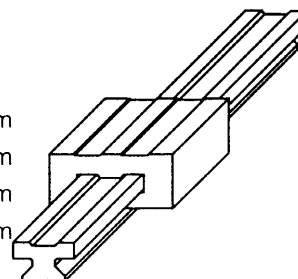

For the exact calculation of the DryLin® T linear guide system it is essential to find out whether the position of the forces is within the allowed limits and if the sliding element where the highest forces occur is not overloaded. The calculation of the possible driving force and the maximum speed allowed is important. The position of the guiding system leads to different formulas for calculation. Factors concerning shocks and acceleration forces are not included in the calculation, therefore the distance between maximum load and allowable load has to be observed.

This analysis cannot provide information regarding the wear or lifetime of the system.

## Procedure

### Preparation

#### 1. Step:

Change the position of the system (p. 8-10)

#### 2. Step:

Control of the distances between the forces and comparison with the maximum distances allowed

### Calculation

#### 3. Step:

Calculation of the necessary driving force (page 8-10)

#### 4. Step:

Calculation of the maximum load on the bearings in y- and z-direction

### Result

#### 5. Step:

Control of the maximum load on the bearings (table page 7), the sliding element where the biggest load occurs (step 4)

#### 6. Step:

Establishing the maximum speed allowed for the calculated loads of step 4. (diagram page 7)



6. step:

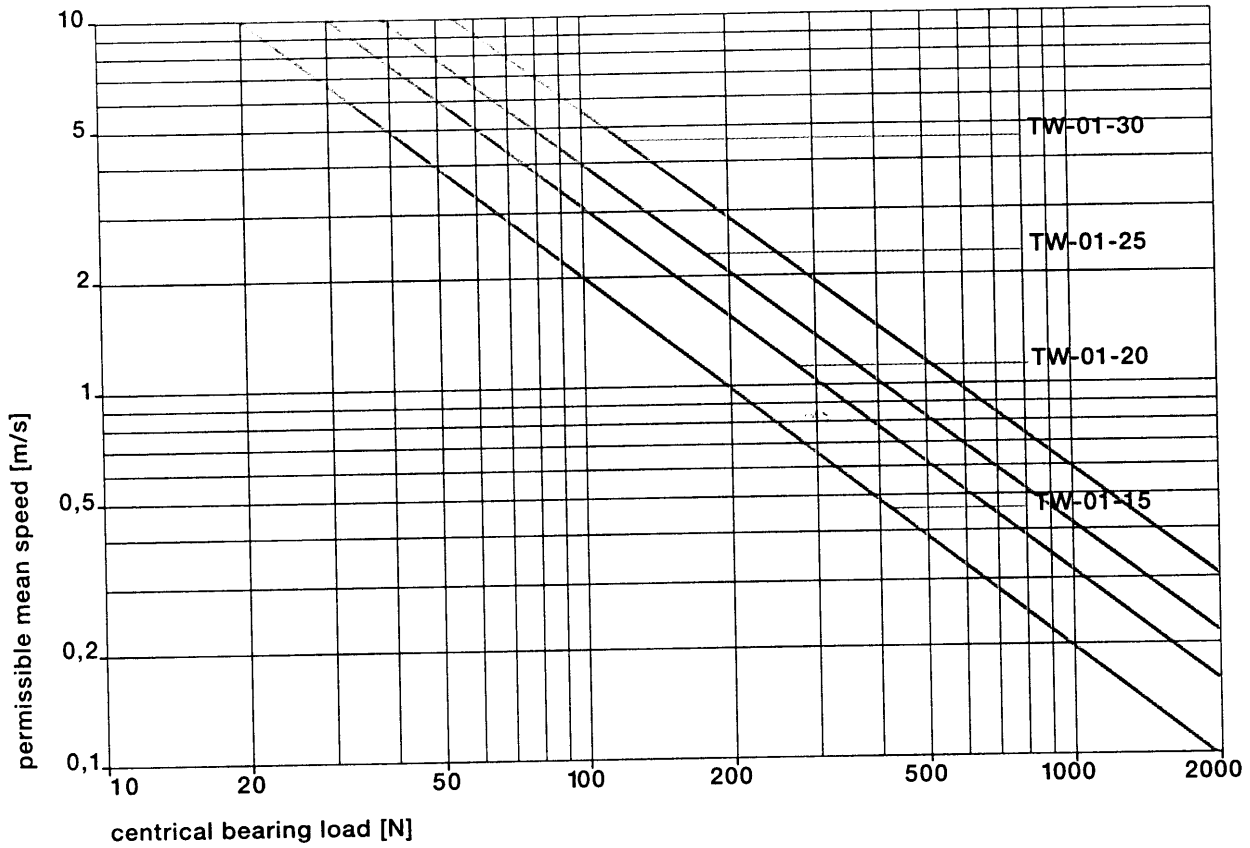

igus® DryLin® T

igus GmbH P.O. Box 906123

51127 Cologne / Germany

Telefon (02203) 9649-0

Telefax (02203) 68950

Internet: <http://www.igus.de>

Mailbox: 0 22 03 - 66 61 54

email: [igus@compuserve.com](mailto:igus@compuserve.com)

5. step

maximum permissible load

Part. No.	F <sub>y</sub> max, F <sub>z</sub> max [N]	Constant factors to allow calculation			
		Pat. No.	L <sub>x</sub> [mm]	Z <sub>M</sub> [mm]	Y <sub>0</sub> [mm]
TW-01-15	2000	TW-01-15	29	16	11,5
TW-01-20	3700	TW-01-20	35	23	15
TW-01-25	5000	TW-01-25	41	25	19
TW-01-30	7000	TW-01-30	49	29	21,5

μ = 0,2 dynamic application

μ = 0 static application

- F<sub>a</sub> : driving force
- F<sub>s</sub> : applied mass force
- F<sub>y</sub>, F<sub>z</sub> : bearing load in y or z direction
- S<sub>x</sub>, S<sub>y</sub>, S<sub>z</sub> : distance of mass force in xy or z direction
- a<sub>y</sub>, a<sub>z</sub> : distance of driving force in xy or z direction
- w<sub>x</sub> : distance of carriages on a rail
- L<sub>x</sub> : constant from table
- Z<sub>M</sub> : constant from table
- Y<sub>0</sub> : constant from table
- b : distance of guide rails
- μ : coefficient of friction

2. step:

maximum allowable distances between the acting forces

Part No.	Sx [mm]	Sy, ay [mm]	Sz, az [mm]
TW-01-15	14	44	55
TW-01-20	17	52	67
TW-01-25	20	59	78
TW-01-30	24	72	93

Horizontal mounting:

3. step: calculate required driving force

$$F_a = \frac{F_s \mu L_x (Z_M + 2S_z)}{Z_M (L_x - 2a_z \mu)}$$

4. step:

maximum bearing load in y direction

$$F_{y_{max}} = F_s \left[ \frac{S_x}{L_x} + \frac{S_z}{Z_M} + 0,5 + \frac{\mu(a_y + Y_o) (Z_M + 2S_z)}{Z_M (L_x - 2a_z \mu)} \right]$$

maximum bearing load in z direction

$$F_{z_{max}} = \frac{2F_s \mu a_z (Z_M + 2S_z)}{Z_M (L_x - 2a_z \mu)}$$

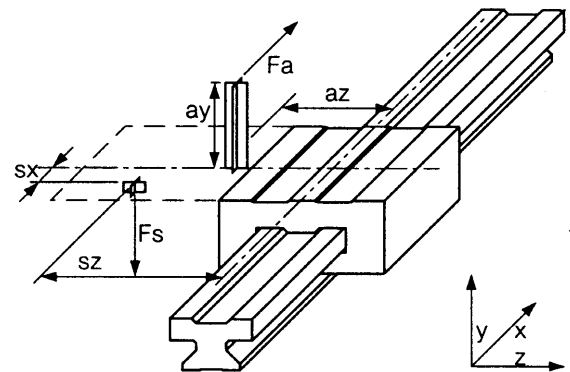

Vertical mounting:

3. step: calculate required driving force

$$F_a = \frac{F_s \mu L_x (Z_M + 2S_y)}{Z_M [L_x - 2\mu (a_y + Y_o)]}$$

4. step:

maximum bearing load in y direction

$$F_{y_{max}} = \frac{F_s}{Z_M} \left[ S_y + Y_o + \frac{\mu (a_y + Y_o) (Z_M + 2S_y)}{L_x - 2\mu (a_y + Y_o)} \right]$$

maximum bearing load in z direction

$$F_{z_{max}} = F_s \left[ 1 + \frac{2S_x}{L_x} + \frac{2\mu a_z (Z_M + 2S_y)}{Z_M [L_x - 2\mu (a_y + Y_o)]} \right]$$

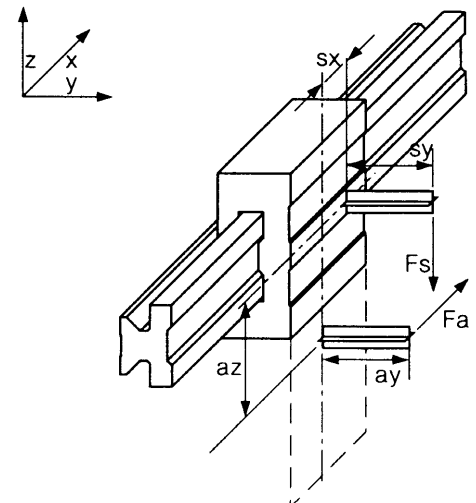

# One rail and two carriages



## 2. step

maximum allowable distances between the acting forces

Part. No.	$s_y, a_y$ [mm]	$s_z, a_z$ [mm]
TW-01-15	$2w_x - 11,5 \text{ mm}$	$2w_x$
TW-01-20	$2w_x - 15 \text{ mm}$	$2w_x$
TW-01-25	$2w_x - 19 \text{ mm}$	$2w_x$
TW-01-30	$2w_x - 21,5 \text{ mm}$	$2w_x$

### Horizontal mounting:

3. step: calculate required driving force

$$F_a = \frac{F_s \mu w_x (Z_M + 2s_z)}{Z_M (w_x - 2a_z \mu)}$$

## 4. step

maximum bearing load in y direction

$$F_{y_{max}} = \frac{F_s}{2} \left[ \frac{s_{xk}}{w_x} + \frac{s_z}{Z_M} + \frac{2\mu (a_y + Y_o) (Z_M + 2s_z)}{Z_M (w_x - 2a_z \mu)} \right]$$

$$s_{xk} = w_x - s_x \quad (\text{if } s_x < 0,5 w_x)$$

$$s_{xk} = s_x \quad (\text{if } w_x > s_x > 0,5 w_x)$$

maximum bearing load in z direction

$$F_{z_{max}} = \frac{F_s \mu a_z (Z_M + 2s_z)}{Z_M (w_x - 2a_z \mu)}$$

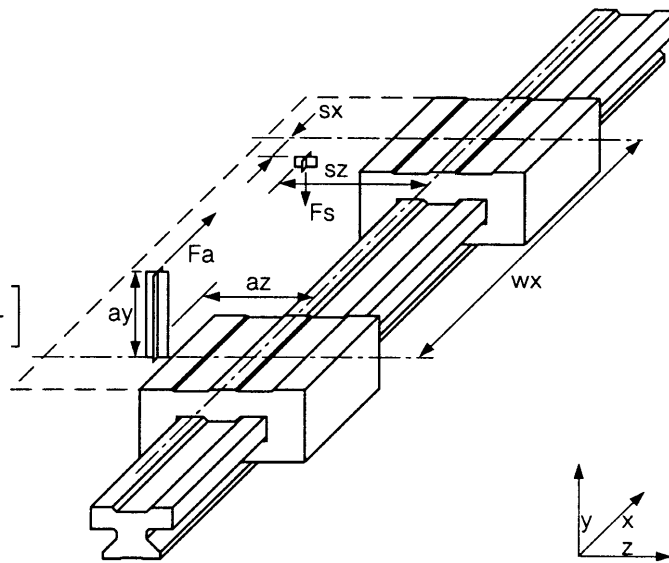

### Vertical mounting:

3. step: calculate required driving force

$$F_a = \frac{F_s \mu w_x [Z_M + 2(s_y + Y_o)]}{Z_M [w_x - 2\mu (a_y + Y_o)]}$$

## 4. step

maximum bearing load in z direction

$$F_{y_{max}} = F_s \left[ 1 - \frac{s_{xk}}{w_x} + \frac{s_y + Y_o}{2Z_M} + \frac{\mu a_z [Z_M + 2(s_y + Y_o)]}{Z_M [w_x - 2\mu (a_y + Y_o)]} \right]$$

$$s_{xk} = w_x - s_x \quad (\text{if } s_x < 0,5 w_x)$$

$$s_{xk} = s_x \quad (\text{if } w_x > s_x > 0,5 w_x)$$

maximum bearing load in y direction

$$F_{y_{max}} = \frac{F_s}{2} \left[ \frac{s_y}{Z_M} + \frac{\mu (a_y + Y_o) [Z_M + 2(s_y + Y_o)]}{Z_M [w_x - 2\mu (a_y + Y_o)]} \right]$$

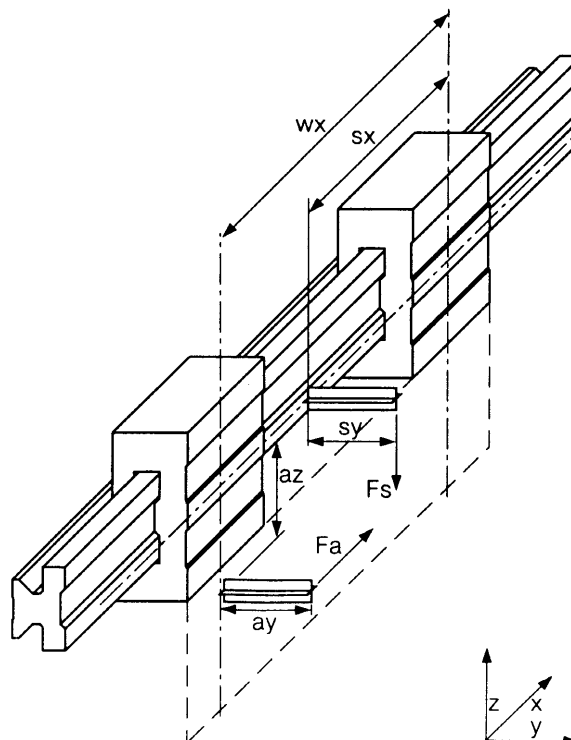

igus® DryLin® T

igus GmbH P.O. Box 906123

51127 Cologne / Germany

Telefon (02203) 9649-0

Telefax (02203) 68950

Internet: <http://www.igus.de>

Mailbox: 0 22 03 - 66 61 54

email: [igus@compuserve.com](mailto:igus@compuserve.com)

**Horizontal mounting:**

3. step: calculate required driving force

$$F_a = \frac{F_s \mu w_x}{w_x - 2 a_z \mu}$$

4. step

maximum bearing load in y direction

$$F_{y_{max}} = \frac{F_s}{2} \left[ \frac{S_{xk} \cdot S_{zk}}{w_x \cdot b} + \frac{\mu (a_y + Y_o)}{2 (w_x - 2 a_z \mu)} \right]$$

$$S_{xk} = w_x - S_x \quad (\text{if } S_x < 0,5 w_x)$$

$$S_{xk} = S_x \quad (\text{if } w_x > S_x > 0,5 w_x)$$

$$S_{zk} = b - S_z \quad (\text{if } S_z < 0,5 b)$$

$$S_{zk} = S_z \quad (\text{if } b > S_z > 0,5 b)$$

maximum bearing load in z direction

$$F_{z_{max}} = \frac{F_s \mu a_z}{w_x - 2 a_z \mu}$$

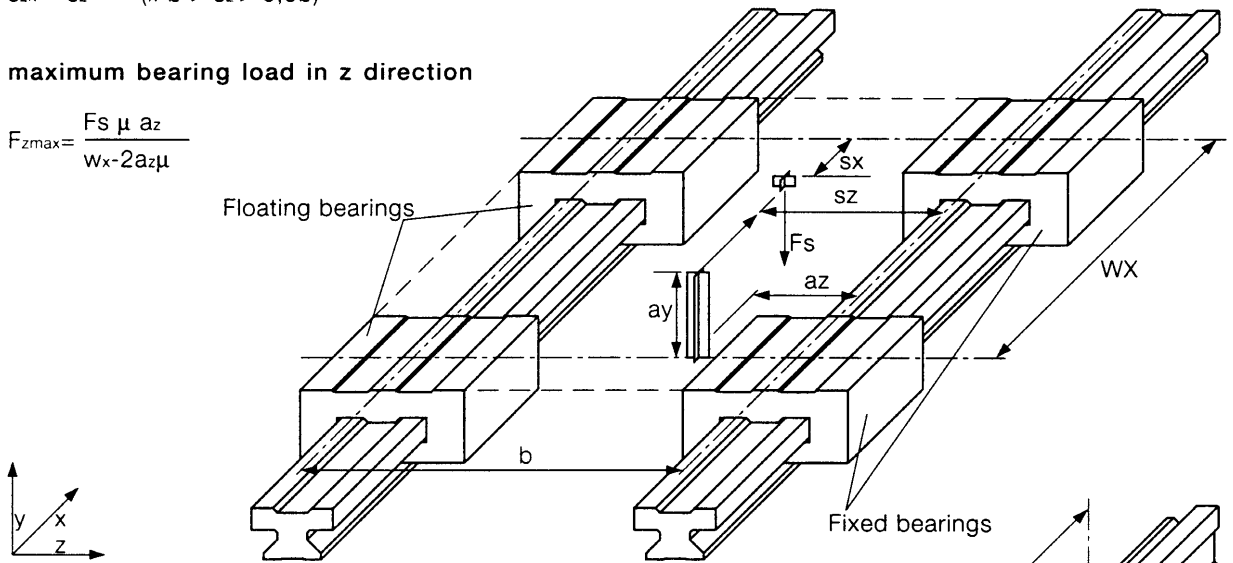

2. step

maximum allowable distances between the acting forces

Part No.	Sy, ay [mm]	Sz, az [mm]
TW-01-15	2wx - 11,5 mm	2wx
TW-01-20	2wx - 15 mm	2wx
TW-01-25	2wx - 19 mm	2wx
TW-01-30	2wx - 21,5 mm	2wx

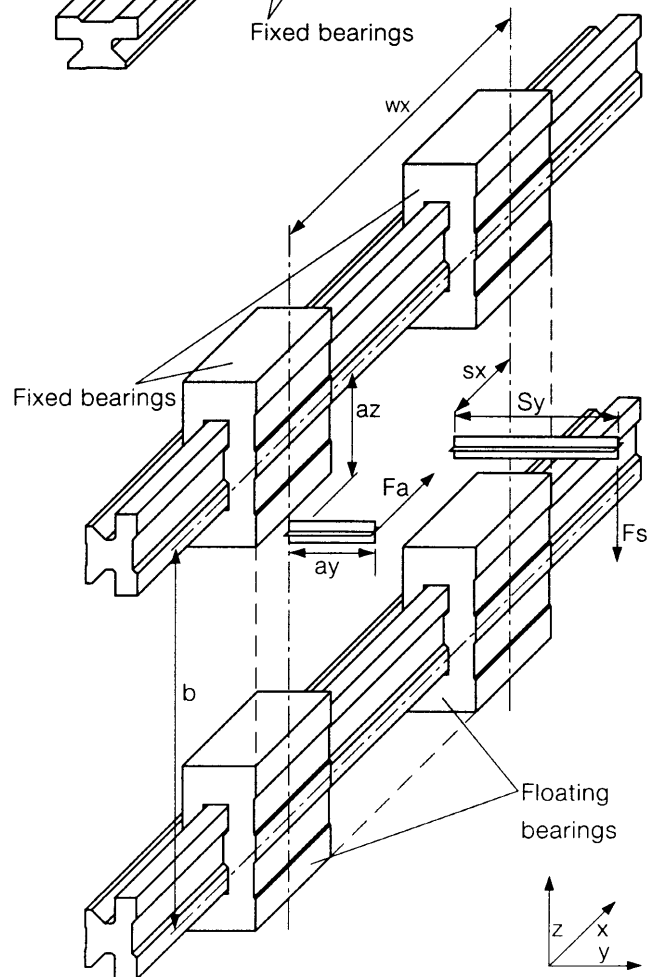

**vertical mounting:**

3. step: calculate required driving force

$$F_a = \frac{F_s \mu w_x [b + 2 (S_y + Y_o)]}{b [w_x - 2 \mu (a_y + Y_o)]}$$

4. step

maximum bearing load in y direction

$$F_{y_{max}} = \frac{F_s}{4} \left[ \frac{(S_y + Y_o)}{b} + \frac{\mu (a_y + Y_o) [b + 2 (S_y + Y_o)]}{b [w_x - 2 \mu (a_y + Y_o)]} \right]$$

maximum bearing load in z direction

$$F_{z_{max}} = F_s \left[ \frac{S_{xk}}{w_x} + \frac{\mu a_z [b + 2 (S_y + Y_o)]}{b [w_x - 2 \mu (a_y + Y_o)]} \right]$$

$$S_{xk} = w_x - S_x \quad (\text{if } S_x < 0,5 w_x)$$

$$S_{xk} = S_x \quad (\text{if } w_x > S_x > 0,5 w_x)$$





The iglidur J material with hard anodised aluminium achieved the best results by far in our tests.

Comprehensive investigations showed that for the relevant loads of linear guides the slide bearings made of iglidur J are the most suitable.

They offer the greatest wear resistance and at the same time guarantee very favourable abrasion values.

Compared to slide partners made of hardened steel it even proved possible to further improve the abrasion resistance by a factor of 3 using gliding partners made of hard anodised aluminium.

**Special Characteristics of iglidur J**

- very low abrasion values during dry operation
- excellent wear resistance
- maintenance-free dry operation
- vibration damping
- very low moisture absorption

**Operating Temperatures**

igidur J slide bearings can be used under temperatures of -40° to a maximum of +90° C. The excellent heat conduction of the aluminium rail means that it is only necessary to take note of the generated friction heat during very high speeds for prolonged periods of time.

**Chemical Resistance**

igidur J is resistant to weak acids, diluted alkalis, as well as fuels and all types of lubricants.

The very low moisture absorption allows them to be used in wet or moist environments.

The resistance to alkalis allows them to be used in applications in which plants or parts of them have to be frequently cleaned.

Medium	Resistance
Alcohols	resistant
Chlorinated hydrocabons	resistant
Ester	not resistant
Fats, oils	resistant
Ketone	resistant to an extent
Fuels	resistant
Weak acids	resistant to an extent
Strong acids	not resistant
Weak lyes	resistant
Strong lyes	resistant
Water	resistant

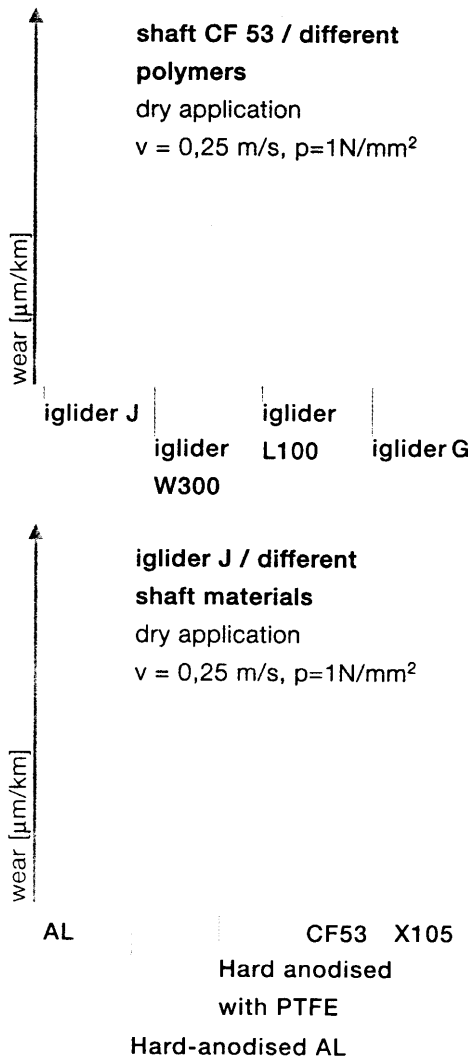

igus® DryLin® T

igus GmbH P.O. Box 906123  
51127 Cologne / Germany

Telefon (02203) 9649-0  
Telefax (02203) 68950

Internet: <http://www.igus.de>  
Mailbox: 0 22 03 - 66 61 54  
email: [igus@compuserve.com](mailto:igus@compuserve.com)



DryLin® T are delivered ready for mounting. The setting of the bearing clearance is carried out at the factory.

The pre-adjustment is carried out on the basis of the displacement force per slide.

If you have special requirements please indicate in your order whether particularly limited or extended bearing play is to be preset.

If required the bearing play of the Dry-Lin® T slides can be readjusted. This should always take place without any additional load:

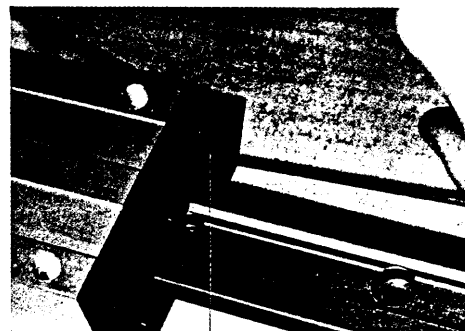
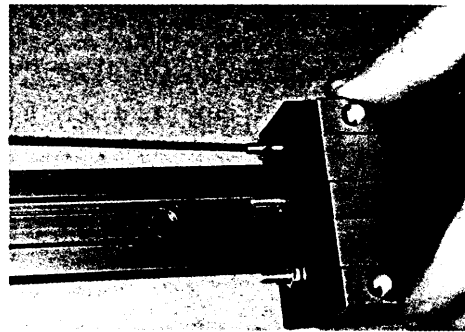
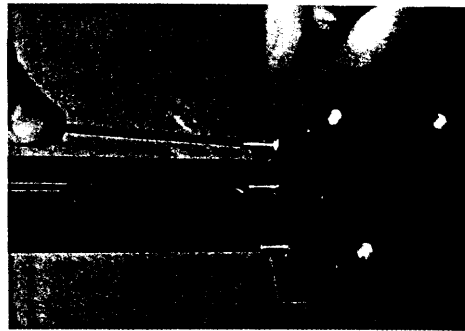

1. First loosen the lock nuts
2. The guide play for the 3 bearing points can then be readjusted with an Allen key. In doing so please check the effectiveness via the sliding forces.
3. After you have adjusted all 3 bearing levels the play on the guide inserts should be checked once again.
4. There is a danger that the excessive reduction of the clearance seizes the slide elements and that the play cannot be re-set simply by loosening the Allen screws. The sliding elements are then loosened again by pressing the **re-set button** on the opposite side. Please use a 3 mm pin for models 25 and 30 and a 2.5 mm pin for the models 15 and 20 to press strongly against the readjusting spring. You must already have loosened the respective hexagon socket screws.

re-set button

## Fitting Instructions



igus

The DryLin® T slide guide rail always requires a small clearance between the slide and rail.

The connecting surface which is screwed to the slide must be very flat, otherwise there is a danger that the slide will be subjected to tension.

When two parallel rails are used one slide must be fitted as a fixed bearing and one slide must be fitted as a floating bearing. When you order we will therefore ask you to describe the fitting situation, preferably on the special order form.

DryLin® T slide rail guides are supplied in assembled and pre-set conditions.

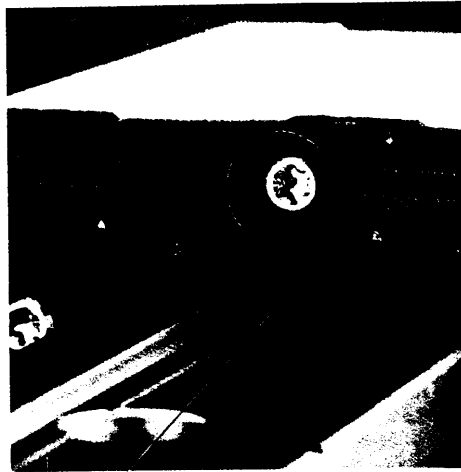

marked

If necessary the slides can be removed for better mounting of the rails.

Please note that the side with endcover which has the part number on the bottom right-hand edge must be first pushed onto the rail.

The setting of the bearing clearance is also to adjust the slide exactly to match the slide rail. Both the rails and the plastic cover of the slide are **marked** to avoid accidentally turning the slide around when mounting.

### Technical Data

Slide Rail	Material	Aluminium, extruded
	Construction material	Al Mg Si 0,5
	Coating	Hard anodised, 50 µm
	Hardness	500 HV
Slide Wagon	Basic body	Aluminium, extruded profile
	Construction material	Al Mg Si 0,5
	Coating	Anodised, E6/EV1
	Slide inserts	Maintenance-free sliding bearing material iglidurJ
	Screws	Galvanised steel
	Springs	Galvanised steel
	Cover	Plastic
Max. Sliding Speed		10 m/s
Temperature Range		-40° ... +90°C

igus® DryLin® T

igus GmbH P.O. Box 906123

51127 Cologne / Germany

Telefon (02203) 9649-0

Telefax (02203) 68950

Internet: <http://www.igus.de>

Mailbox: 0 22 03 - 66 61 54

email: [igus@compuserve.com](mailto:igus@compuserve.com)