

Description

ACE722A is a 420kHz fixed frequency PWM buck (step-down) DC-DC converter, capable of driving a 2A load with high efficiency, low ripple and excellent line and load regulation. The device includes a voltage reference, an oscillation circuit, an error amplifier, an internal PMOS and etc.

The PWM control circuit is able to adjust the duty ratio linearly from 0 to 100%. The enable function, over current protection function, short circuit protection function and soft-start function are built inside. When OCP or SCP happens, the operation frequency will be reduced from 420kHz to 40kHz. An internal compensation block is employed to minimize external components.

The ACE722A serves as an ideal power supply unit for portable devices, especially for chip set power in portable systems. It's widely used for PDVD, LCD monitor and DPF chip set powers.

Features

- 2A Constant Output Current
- 130mΩ R_{DS(on)} Internal Power MOSFET Switch
- Up to 94% Efficiency
- Fixed 420kHz Frequency
- Wide 4.75V to 25V Input Voltage Range
- Output Voltage Adjustable from 0.8V to 21V
- Built in Thermal Shutdown Function
- Built-in Current Limit Function
- Built-in Soft-Start Function
- Support Ceramic or Electrolytic Capacitors

Application

- Portable DVE
- LCD Monitor/LCD TV
- Digital Photo Frame
- ADSL
- Set-up Box

Absolute Maximum Ratings

Parameter	Symbol	Max	Unit
Input Voltage	V _{IN}	-0.3 to 30	V
FB Pin Voltage	V _{FB}	-0.3 to 6	V
EN Pin Voltage	V _{EN}	-0.3 to V _{IN}	V
COMP Pin Voltage	V _{COMP}	-0.3 to 6	V
SW Pin Voltage	V _{SW}	-0.3 to V _{IN}	V
Power Dissipation	P _D	Internally Limited	mW
Thermal Resistance (Junction to Ambient, No Heat Sink, Free AIR)	θ _{JA}	100	°C/W
Operating Junction Temperature	T _J	150	°C
Storage Temperature	T _{STG}	-65 to 150	°C
Lead Temperature (Soldering, 10sec)	T _{LEAD}	260	°C
ESD (Human Body Model)	ESD	2000	V

Note 1: Stresses greater than those listed under “Absolute Maximum Ratings” may cause permanent damage to the device. These are stress ratings only, and functional operation of the device at these or any other conditions beyond those indicated under “Recommended Operating Conditions” is not implied. Exposure to “Absolute Maximum Ratings” for extended periods may affect device reliability.

Packaging Type

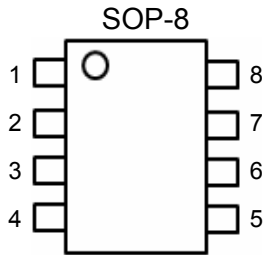

Pin	SOP-8	Function
1	NC	Not Connected
2	VIN	Supply Voltage Input Pin. ACE722A operates from a 4.75V to 25V DC voltage. Bypass VIN to GND with a suitable large capacitor to eliminate noise on the input.
3	SW	Power Switch Output Pin. SW is the switch node that supplies power to the output.
4	GND	Ground Pin
5	FB	Feedback Pin. Through an external resistor divider network, FB senses the output voltage and regulates it. To prevent current limit run away in a short circuit fault condition, the frequency feedback comparator lowers the oscillator frequency to 40kHz when the FB voltage is below 0.52V. The feedback threshold voltage is 0.8V.
6	COMP	Compensation Pin. This pin is the output of the error amplifier. Frequency compensation is done at this pin by connecting a series RC to ground (parallel a C if necessary)
7	EN	Enable Pin. Drive EN pin high to turn on the device, drive it low to turn off. Default of this pin is high level.
8	NC	Not Connected

Ordering information

Selection Guide

ACE722A XX + H

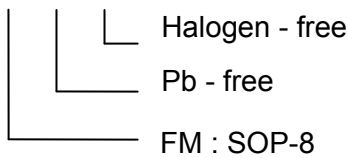

Block Diagram

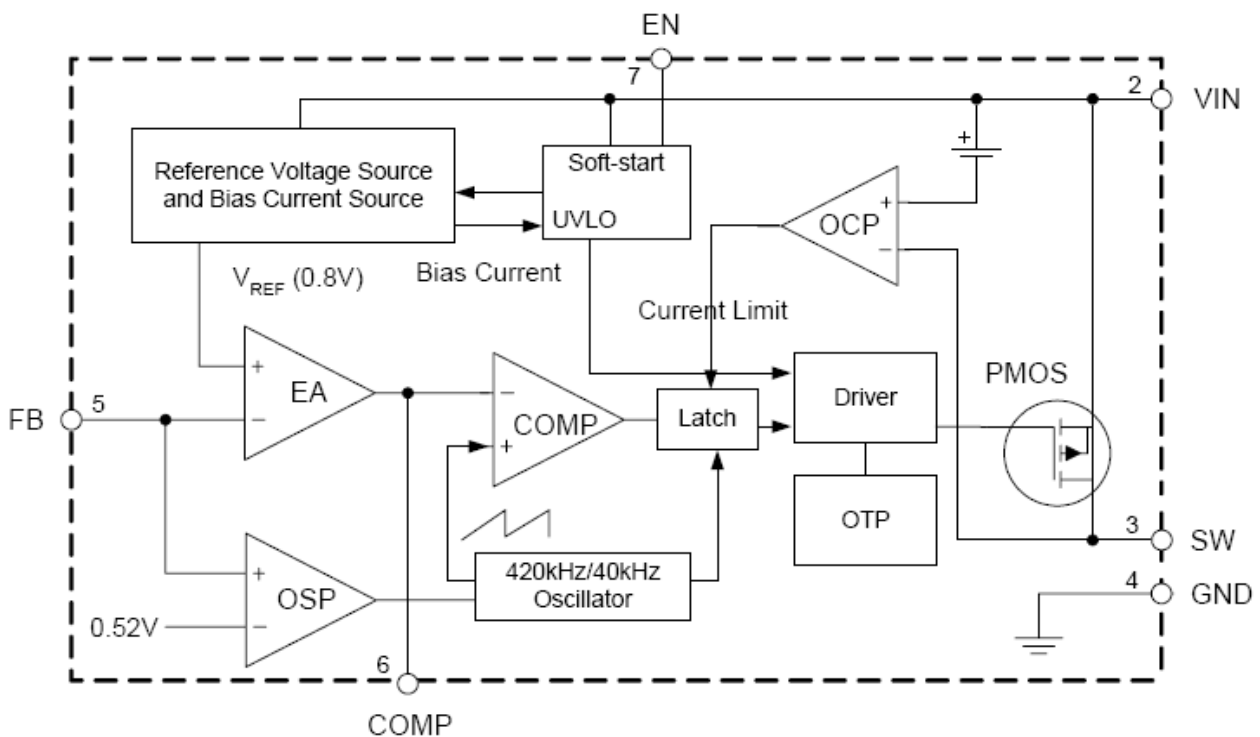

Recommended Operating Conditions

Parameter	Symbol	Min	Max	Unit
Input Voltage	V_{IN}	4.75	25	V
Output Voltage	V_{OUT}	0.8	21	V
Operating Junction Temperature	T_J	-40	125	°C

Electrical Characteristics

(V_{CC}=12V, V_{OUT}=5V, T_A=25°C, unless otherwise noted.)

Parameter	Symbol	Conditions	Min	Typ	Max	Units
Input Voltage	V _{IN}		4.75		25	V
Shutdown Quiescent Current	I _{SHDN}	V _{EN} =0.4V		44	60	μA
Quiescent Current	I _Q	V _{EN} =2V, V _{FB} =1.3V		1.3	2	mA
Feedback Voltage	V _{FB}	V _{IN} =5V to 25V	0.784	0.8	0.816	V
Feedback Bias Current	I _{FB}	V _{FB} =1.3V		-0.1	-0.5	μA
Switch Current Limit	I _{LIM}		2.5	3.4		A
Oscillator Frequency	fosc		336	420	504	kHz
Frequency of Current Limit or Short Circuit Protection	fosc1	V _{FB} <0.52V		40		kHz
Error Amplifier Voltage Gain	G _V			1000		V/V
Error Amplifier Transconductance	G _S			700		μA/V
EN Pin Threshold	V _H		1.5			V
	V _L				0.7	V
EN Pin Input Leakage Current	I _{EN}	V _{EN} =2.5V		-5	-10	μA
Internal PMOS ON Resistance	R _{DSON}	V _{IN} =12V V _{FB} =0.65V V _{EN} =12V, I _{OUT} =2A		130	150	mΩ
Maximum Duty Cycle	D _{MAX}	V _{FB} =0.65V, I _{SW} =0.1A			100	%
Thermal Shutdown	T _{OTSD}			155		°C
Thermal Shutdown Hysteresis	T _{HYS}			20		°C

Typical Performance Characteristics

V_{CC}=12V, V_{OUT}=5V, T_A=25°C, unless otherwise specified

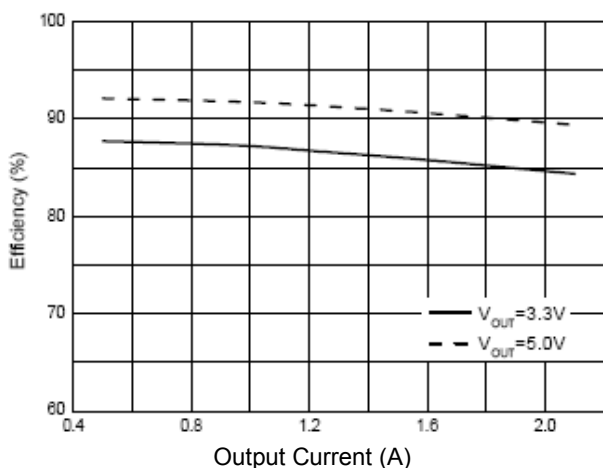

Figure 1. Efficiency vs. Output Current

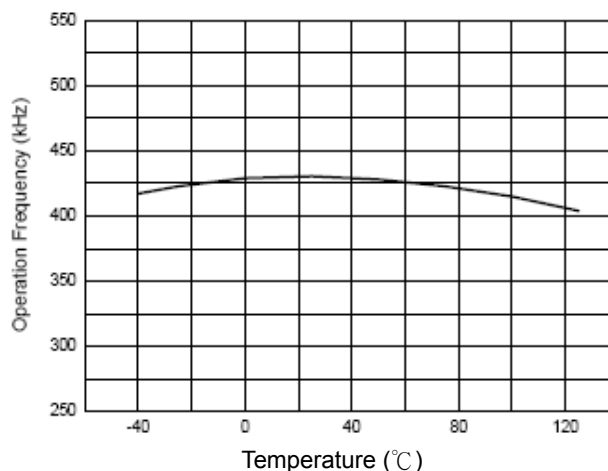

Figure 2. Operation Frequency vs. Temperature

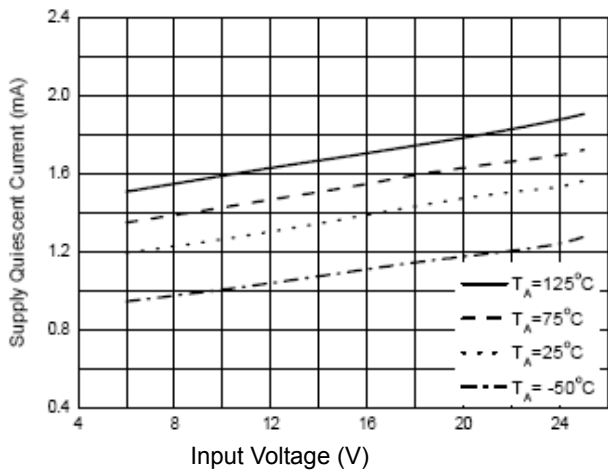

Figure 3. Supply Quiescent Current vs. Input Voltage

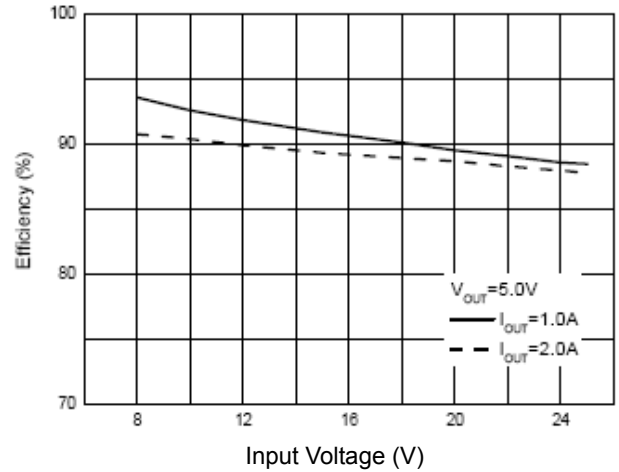

Figure 4. Efficiency vs. Input Voltage

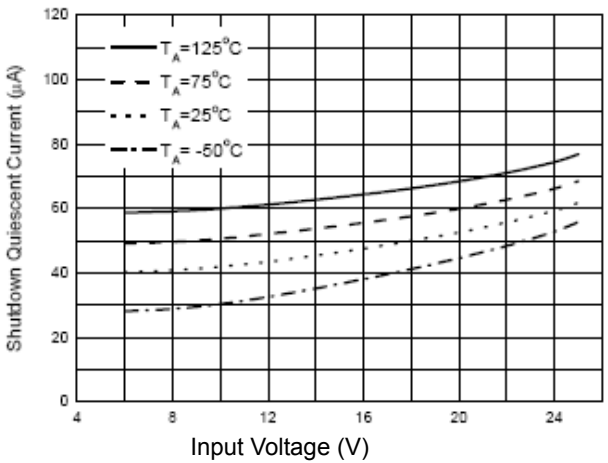

Figure 5. Shutdown Quiescent Current vs. Input Voltage

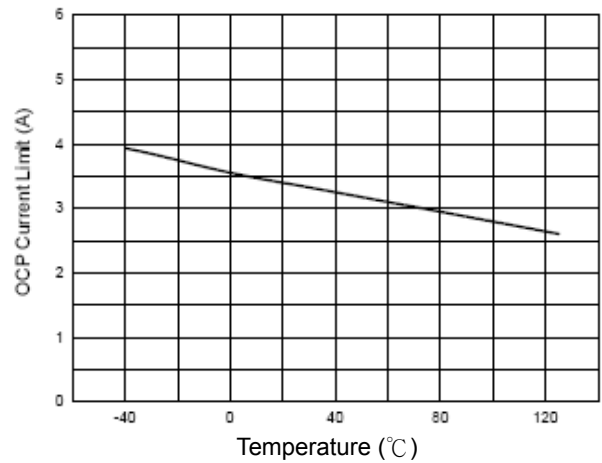

Figure 6. OCP Current Limit vs. Temperature

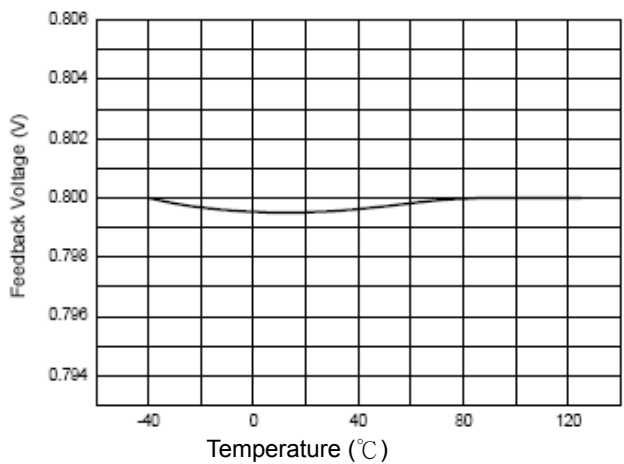

Figure 7. Feedback Voltage vs. Temperature

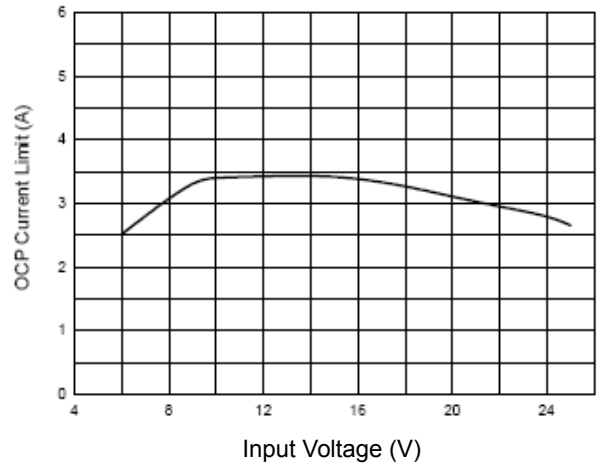

Figure 8. OCP Current Limit vs. Input Voltage

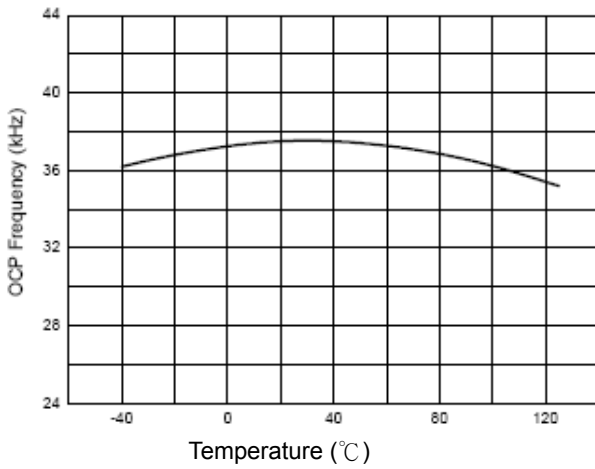

Figure 9. OCP Frequency vs. Temperature

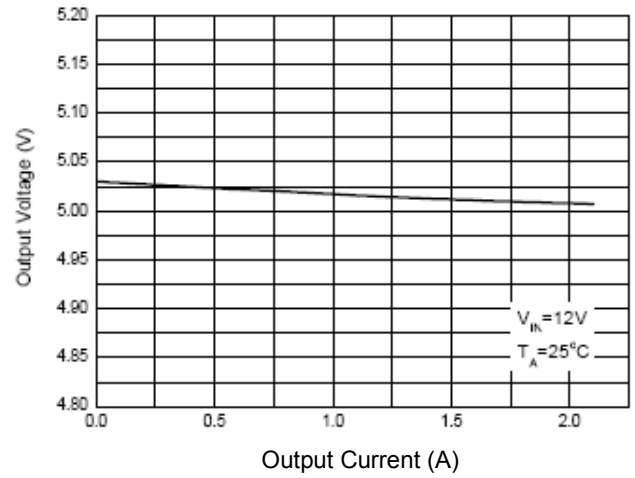

Figure 10. Output Voltage vs. Output Current

Typical Application

($V_{IN} = 12V$, $V_{OUT} = 5V$, $I_{OUT} = 2A$)

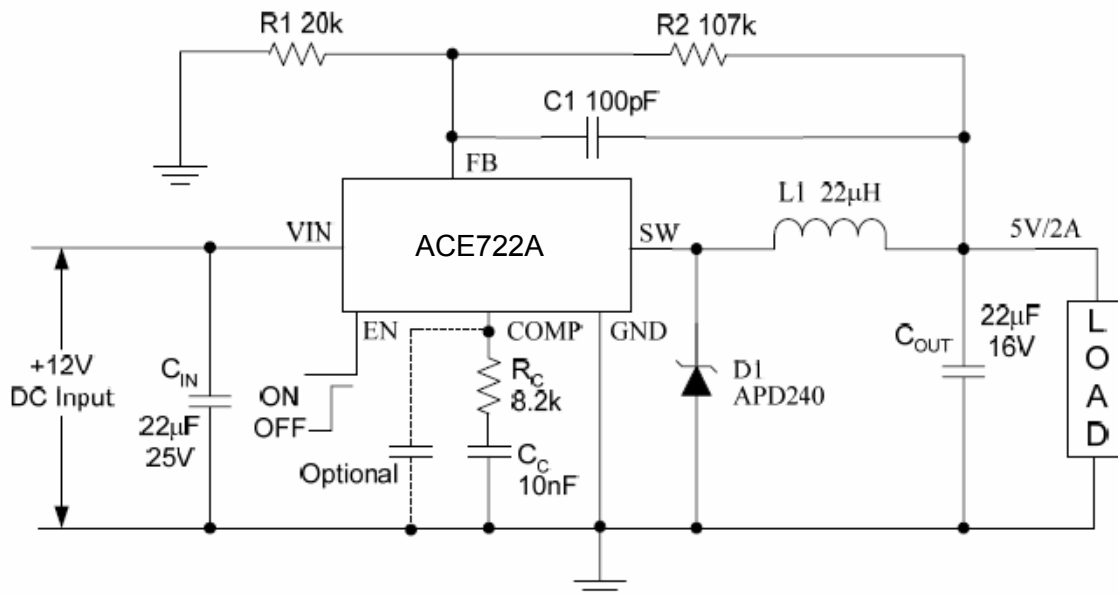

Figure 11. Typical Application 1 of ACE722A Applied with Ceramic Input and Output Capacitors

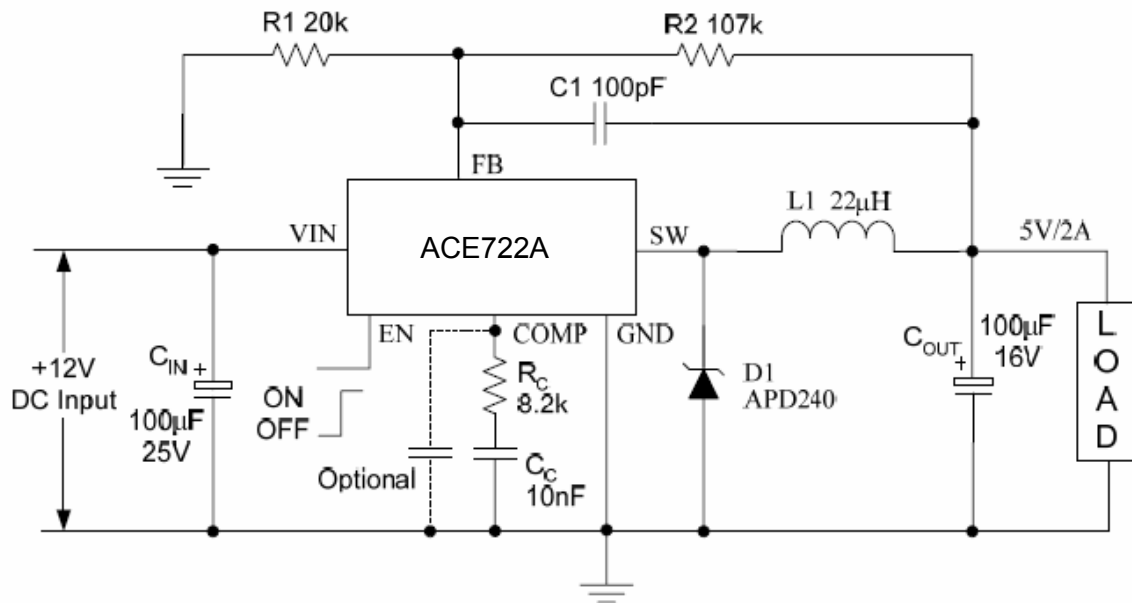
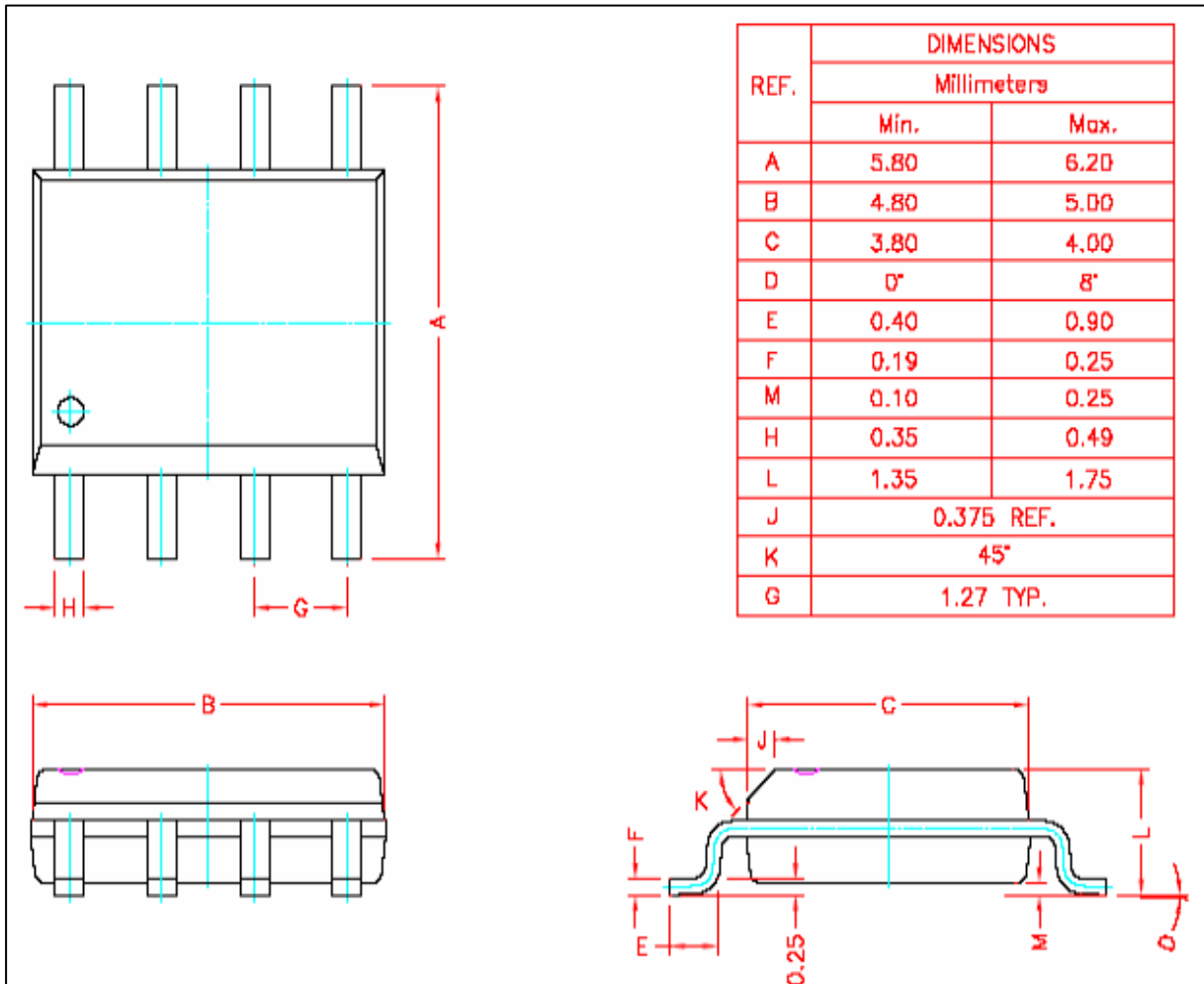

Figure 12. Typical Application 2 of ACE722A Applied with Electrolytic Input and Output Capacitors

Packing Information

SOP-8



Notes

ACE does not assume any responsibility for use as critical components in life support devices or systems without the express written approval of the president and general counsel of ACE Electronics Co., LTD. As sued herein:

1. Life support devices or systems are devices or systems which, (a) are intended for surgical implant into the body, or (b) support or sustain life, and whose failure to perform when properly used in accordance with instructions for use provided in the labeling, can be reasonably expected to result in a significant injury to the user.
2. A critical component is any component of a life support device or system whose failure to perform can be reasonably expected to cause the failure of the life support device or system, or to affect its safety or effectiveness.

ACE Technology Co., LTD.
<http://www.ace-ele.com/>