

APPROVAL SHEET

WA04X

±5%, Convex Type

General purpose chip resistors array

Size 0402x4

Customer : _____

Approval No : _____

Issue Date : _____

Customer Approval :

Walsin Technology Corporation

FEATURE

1. Small size and light weight
2. Reduced size of final equipment
3. Lower surface mounted assembly costs
4. Higher component and equipment reliability
5. Lead (Pb) free product is available

APPLICATION

- Consumer electrical equipment, PDA, Digital Camcorder, ...
- EDP, Computer application
- Mobile phone, Telecom

DESCRIPTION

The resistors array is constructed in a high grade ceramic body (aluminum oxide). Internal metal electrodes are added at each end and connected by a resistive paste that is applied to the top surface of the substrate. The composition of the paste is adjusted to give the approximate resistance required and the value is trimmed to within tolerance by laser cutting of this resistive layer.

The resistive layer is covered with a protective coat. Finally, the two external end terminations are added. For ease of soldering the outer layer of these end terminations is a Lead-tin or Tin (Lead free) solder alloy.

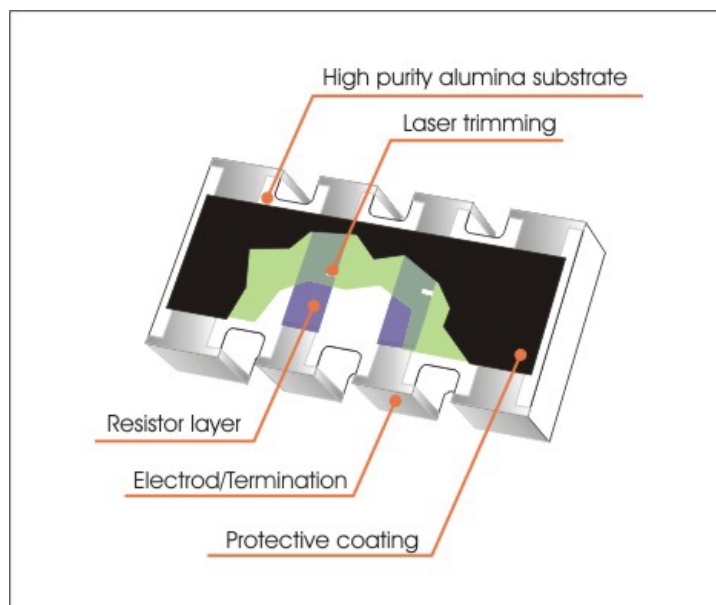

Fig 1. Constraction of a Chip-R array WA04

Walsin Technology Corporation

QUICK REFERENCE DATA

Item	General Specification
Series No.	WA04X(Convex)
Size	0402x4 (1005x4)
Resistance Tolerance	±5%
Resistance Range	10Ω ~ 1MΩ Jumper
TCR (ppm/°C) 10Ω≤R<1MΩ R<10Ω, R>1MΩ	≤ ± 300 -300~+500
Max. dissipation at T _{amb} =70°C	1/16 W
Max. Operation Voltage (DC or RMS)	25V
Max. overload voltage	50V
Climatic category	55/155/56

Note :

1. This is the maximum voltage that may be continuously supplied to the resistor element, see "IEC publication 60115-8"
2. Max. Operation Voltage : So called RCWV (Rated Continuous Working Voltage) is determined by

$$RCWV = \sqrt{\text{Rated Power} \times \text{Resistance Value}} \text{ or Max. RCWV listed above, whichever is lower.}$$

DIMENSIONS

	WA04X
L	2.00 ± 0.10
W	1.00 ± 0.10
T	0.45 ± 0.10
P	0.50 ± 0.05
A	0.40 ± 0.10
B	0.20 ± 0.10
C	0.30 ± 0.05
G	0.25 ± 0.10

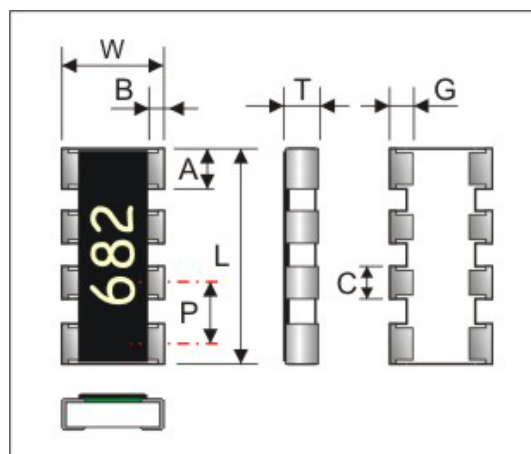

CONSTRUCTION

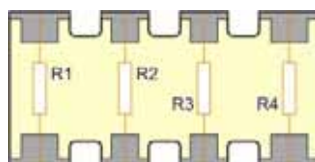

$$R1=R2=R3=R4$$

Walsin Technology Corporation

MARKING

3-digits marking

Each resistor is marked with three digits on the protective coating to designate the nominal resistance value.

For values below 100Ω the 0 is used as a final digit. For values of 1KΩ or greater the first 2 digits apply to the resistance value and 3rd digit indicates the multiple number of zero.

Example

RESISTANCE	10Ω	12Ω	100Ω	6800Ω	47000Ω
3-digits marking	100	120	101	682	473

FUNCTIONAL DESCRIPTION

Product characterization

Standard values of nominal resistance are taken from the E24 series for resistors with a tolerance of $\pm 5\%$, The values of the E24 series are in accordance with "IEC publication 60063"

Derating

The power that the resistor can dissipate depends on the operating temperature; see Fig.2

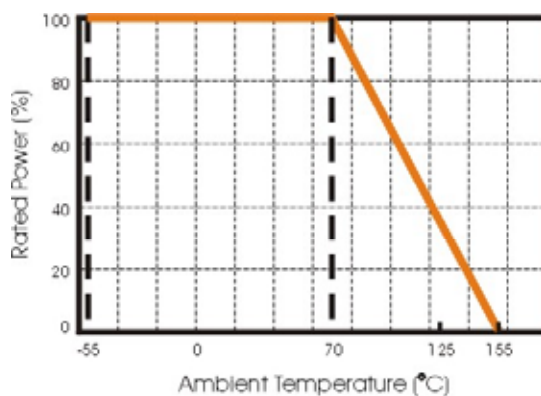

Figure 2. Maximum dissipation in percentage of rated power
As a function of the ambient temperature

Walsin Technology Corporation

CATALOGUE NUMBERS

The resistors have a catalogue number starting with .

WA04	X	472_	J	T	_
Size code WA04 : 0402 per element	Type code X : x4, convex	Resistance code E24 : 2 significant digits followed by no. of zeros and a blank 10Ω =100_ 220Ω =221_ Jumper =000_ (“_” means a blank)	Tolerance J : ±5% P : Jumper	Packaging code T : 7" Reel taping	Termination code _ = SnPb base (“_” means a blank) L = Sn base (lead free)

1. Reeled tape packaging : 8mm width paper taping 10,000pcs per reel.

MOUNTING

Due to their rectangular shapes and small tolerances, Surface Mountable Resistors are suitable for handling by automatic placement systems.

Chip placement can be on ceramic substrates and printed-circuit boards (PCBs).

Electrical connection to the circuit is by individual soldering condition.

The end terminations guarantee a reliable contact.

SOLDERING CONDITION

The robust construction of chip resistors allows them to be completely immersed in a solder bath of 260°C for one minute. Therefore, it is possible to mount Surface Mount Resistors on one side of a PCB and other discrete components on the reverse (mixed PCBs).

Surface Mount Resistors are tested for solderability at 235°C during 2 seconds. The test condition for no leaching is 260°C for 60 seconds. Typical examples of soldering processes that provide reliable joints without any damage are given in Fig 3.

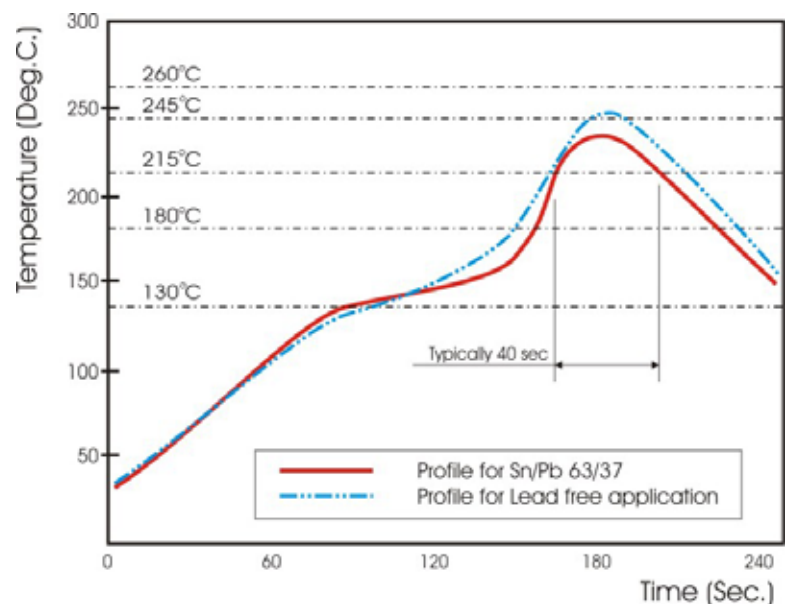

Fig 3. Infrared soldering profile for Chip Resistors array

TEST CONDITION FOR JUMPER (0 Ω)

Item	WA04X
Power Rating At 70°C	1/16W
Resistance	MAX. 50mΩ
Rated Current	1A
Peak Current	1.5A
Operating Temperature	-55~155°C

TEST AND REQUIREMENTS(JIS C 5201-1 : 1998)

TEST	PROCEDURE	REQUIREMENT	
		Resistor	Jumper
DC resistance Clause 4.5	DC resistance values measured at the test voltages specified below : <10Ω@0.1V,<100Ω@0.3V,<1KΩ@1.0V,<10KΩ@3V, <100KΩ@10V, <1MΩ@25V, <10MΩ@30V	Within the specified tolerance	< 50mΩ
Temperature Coefficient of Resistance (T.C.R) Clause 4.8	Natural resistance change per change in degree centigrade. $\frac{R_2 - R_1}{R_1(t_2 - t_1)} \times 10^6 \text{ (ppm/°C)}$ $t_1 : 20^\circ\text{C}+5^\circ\text{C}-1^\circ\text{C}$ R ₁ : Resistance at reference temperature R ₂ : Resistance at test temperature	Refer to "QUICK REFERENCE DATA"	N/a
Short time overload (S.T.O.L) Clause 4.13	Permanent resistance change after a 5second application of a voltage 2.5 times RCWV or the maximum overload voltage specified in the above list, whichever is less.	ΔR/R max. ±(2%+0.10Ω)	< 50mΩ
Resistance to Soldering Heat (R.S.H) Clause 4.18	Un-mounted chips completely immersed for 10±1second in a solder bath at 270 ±5°C	R/R max. ±(1%+0.05) no visible damage	< 50mΩ
Solderability Clause 4.17	Un-mounted chips completely immersed for 2±0.5second in a solder bath at 235 ±5	good tinning (>95% covered) no visible damage	
Leaching Test Clause 4.18	Un-mounted chips completely immersed for 60±1second in a solder bath at 260 ±5	Ditto	
Temperature cycling Clause 4.19	30 minutes at -55°C±3°C, 2~3 minutes at 20°C+5°C-1°C, 30 minutes at +155°C±3°C, 2~3 minutes at 20°C+5°C-1°C, total 5 continuous cycles	R/R max. ±(1%+0.05) no visible damage	< 50mΩ
Load life (endurance) Clause 4.25	70±2°C, 1000 hours, loaded with RCWV or Vmax,1.5 hours on and 0.5 hours off	R/R max.±(3%+0.10) For 10Ω≤R<1MΩ ; R/R max.±(5%+0.10) For R<10Ω, R≥1MΩ	< 50mΩ
Load life in Humidity Clause 4.24	1000 hours, at rated continuous working voltage in humidity chamber controller at 40°C±2°C and 90~95% relative humidity, 1.5hours on and 0.5 hours off	R/R max.±(3%+0.10) For 10Ω≤R<1MΩ ; R/R max.±(5%+0.10) For R<10Ω, R≥1MΩ	< 50mΩ
Adhesion Clause 4.32	Pressurizing force: 5N, Test time: 10±1sec.	No remarkable damage or removal of the terminations.	

Walsin Technology Corporation

PACKAGING

Paper Tape specifications (unit :mm)

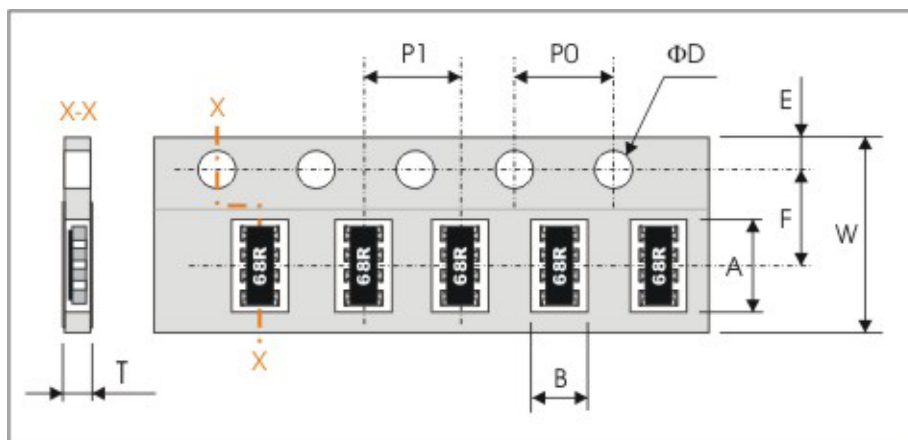

Series No.	A	B	W	F	E
WA04X	2.20±0.20	1.20±0.20	8.00±0.30	3.50±0.20	1.75±0.10

Series No.	P1	P0	ΦD	T
WA04X	2.00±0.05	4.00±0.10	Φ1.50 ^{+0.1} _{-0.0}	Max. 0.6

Reel dimensions

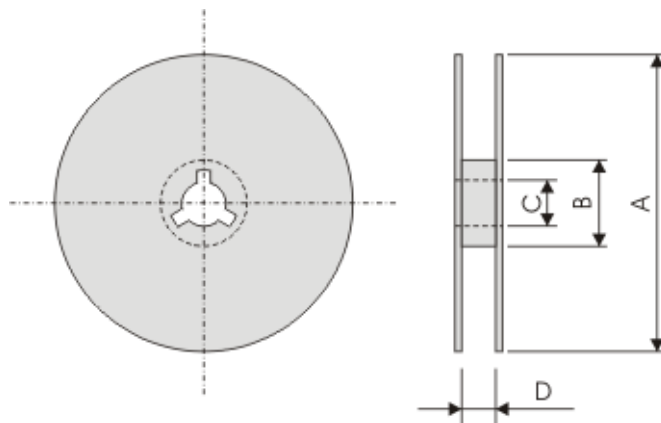

Symbol	A	B	C	D
(unit : mm)	Φ178.0±2.0	Φ60.0±1.0	13.0±0.2	9.0±0.5