

Wireless Bipolar Power Transistor, 60W

1450 - 1550 MHz

PH1516-60

Features

- Designed for Linear Amplifier Applications
- Class AB: -30 dBc Typ 3rd IMD at 60 Watts PEP
- Class A: +53 dBm Typ 3rd Order Intercept Point
- Common Emitter Configuration
- Internal Input Impedance Matching
- Diffused Emitter Ballasting

Absolute Maximum Ratings at 25°C

Parameter	Symbol	Rating	Units
Collector-Base Voltage	V_{CBO}	65	V
Collector-Emitter Voltage	V_{CES}	65	V
Emitter-Base Voltage	V_{EBO}	3.0	V
Collector Current	I_C	10	A
Power Dissipation	P_D	116	W
Junction Temperature	T_J	200	°C
Storage Temperature	T_{STG}	-55 to +150	°C
Thermal Resistance	θ_{JC}	1.5	°C/W

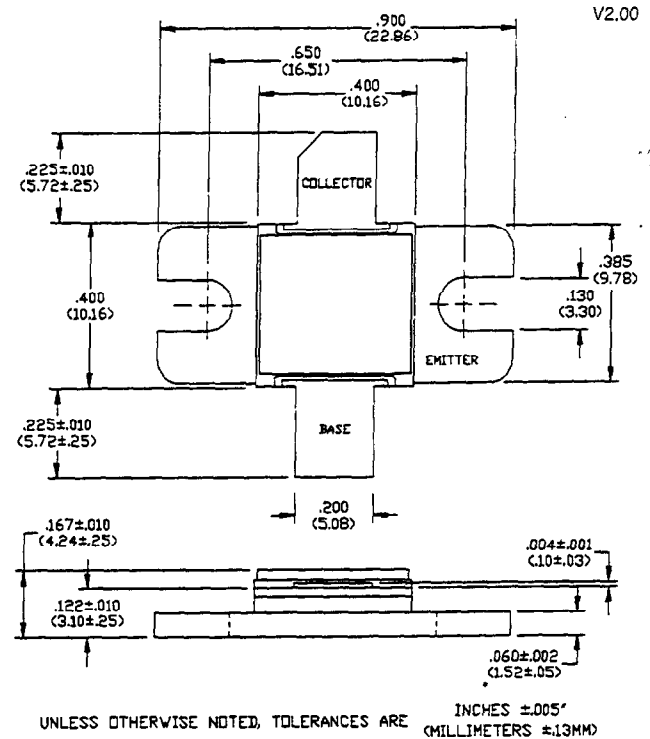

Electrical Characteristics at 25°C

Parameter	Symbol	Min	Max	Units	Test Conditions
Collector-Emitter Breakdown Voltage	BV_{CES}	60	-	V	$I_C=40$ mA
Collector-Emitter Leakage Current	I_{CES}	-	10	mA	$V_{CE}=26$ V
Collector-Emitter Breakdown Voltage	BV_{CEO}	24	-	V	$I_C=40$ mA
Emitter-Base Breakdown Voltage	BV_{EBO}	3.0	-	V	$I_B=40$ mA
DC Forward Current Gain	h_{FE}	15	120	-	$V_{CE}=5$ V, $I_C=1$ A
Power Gain	G_P	8	-	dB	$V_{CC}=26$ V, $I_{CO}=50$ mA, $P_{OUT}=60$ W PEP F=1500 MHz, $\Delta F=100$ kHz
Collector Efficiency	η_C	30	-	%	$V_{CC}=26$ V, $I_{CO}=50$ mA, $P_{OUT}=60$ W PEP F=1500 MHz, $\Delta F=100$ kHz
Input Return Loss	RL	10	-	dB	$V_{CC}=26$ V, $I_{CO}=50$ mA, $P_{OUT}=60$ W PEP F=1500 MHz, $\Delta F=100$ kHz
Load Mismatch Tolerance	VSWR-T	-	5.0:1	-	$V_{CC}=26$ V, $I_{CO}=50$ mA, $P_{OUT}=60$ W PEP F=1500 MHz, $\Delta F=100$ kHz
3rd Order IMD	IMD_3	-	-28	dBc	$V_{CC}=26$ V, $I_{CO}=50$ mA, $P_{OUT}=60$ W PEP F=1500 MHz, $\Delta F=100$ kHz

Typical Optimum Device Impedances

F(MHz)	$Z_{IN}(\Omega)$	$Z_{LOAD}(\Omega)$
1450	$2.2 + j5.0$	$3.0 - j3.8$
1500	$2.7 + j4.5$	$2.2 - j4.0$
1550	$2.1 + j3.7$	$1.5 - j4.1$

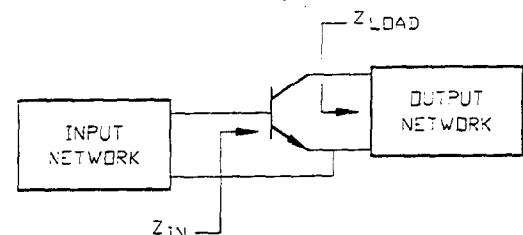

RF Test Fixture

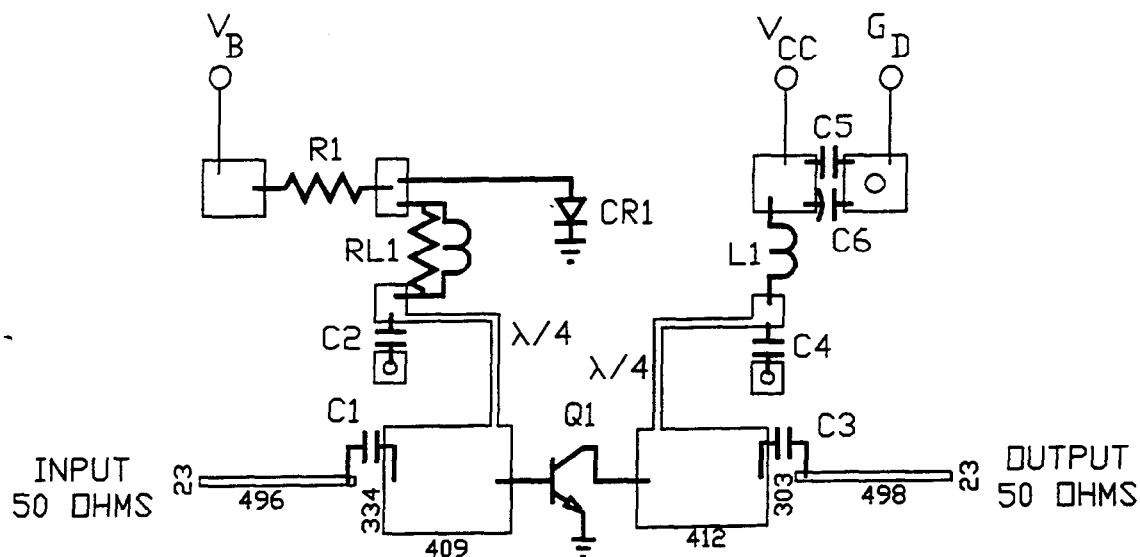

ARTWORK DIMENSIONS IN MILS

PARTS LIST

C1	C2	C3	C4	18pF ATC SIZE B CAPACITOR
C5				5000pF CHIP CAPACITOR
C6				50 VOLT 50 μ F ELECTROLYTIC CAPACITOR
CR1				1N5417 DIODE
L1				7 TURNS OF NO. 22 AWG ON .125" DIA
Q1				PH1516-60
R1				4.7 OHM 1/2 WATT RESISTOR
RL1				10 TURNS OF NO. 26 AWG ON 3 OHM 1/4 WATT RESISTOR
BOARD TYPE:				ROGERS 6010.5 .025" THICK, $E_R = 10.5$

Typical Broadband Performance Curves

