

V854™ 32-BIT RISC MICROCONTROLLER

The high-speed, low-voltage, low-power V854 microcontroller features on-chip DSP functionality with 128K single-cycle flash memory and the advanced 32-bit RISC engine of NEC's V850™ family. The V854 microcontroller provides standard on-chip peripherals such as D/A and A/D converters, complex timers, and serial interfaces (including I²C™) while maintaining exceptionally low power consumption (118 mW at 33 MHz) and 3V low-voltage operation. When combined with the integrated multiply and accumulate (MAC) function, the device offers an efficient and cost-effective solution for wireless and multimedia applications.

Many versions of the V850 core are available as part of NEC's ASIC library. The architecture of the V854 device is highly optimized for fast DSP-like operation and very efficient implementation of C programmability.

SPECIFICATIONS

- Clock frequency: DC to 33 MHz
- Performance
 - 38 Dhrystone MIPS
 - 322 MIPS/W
- Two-cycle MAC instruction
- Single-cycle frequency shift
- 2.7–3.6V operation
- Power consumption: 118 mW at 33 MHz
- 0.35- μ m CMOS process technology
- 6.3 mm x 6.4 mm die size
- Package
 - 144-pin plastic QFP
 - 20 mm x 20 mm

BLOCK DIAGRAM

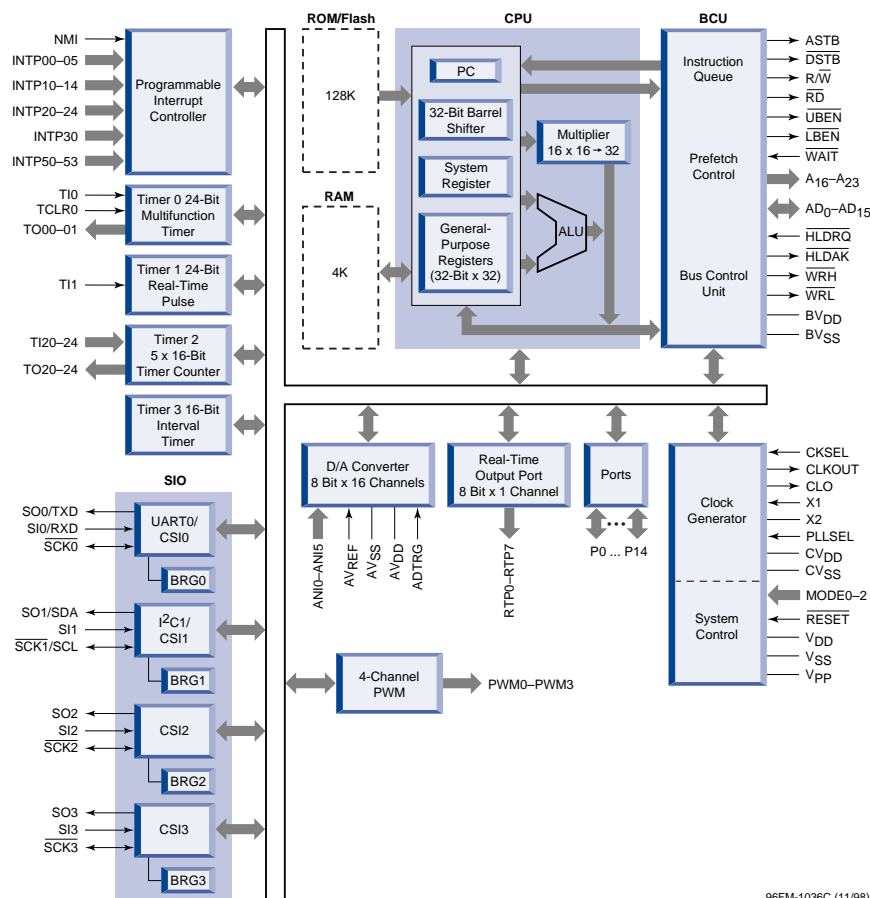

FEATURE DESCRIPTION

CPU

- **Highly integrated microcontroller**
 - 32-bit arithmetic logic unit (ALU)
 - Thirty-two general-purpose 32-bit registers
 - 32-bit barrel shifter
- **Single-cycle 16 x 16 → 32-bit hardware multiplier**
- **Powerful RISC instruction set**
 - 74 RISC instructions: 16- and 32-bit
 - Two-cycle MAC function for DSP applications
 - Saturated operation instructions (overflow/underflow detection function)
 - Single-cycle 32-bit shift instructions
 - Bit manipulation instructions
 - Load and store instructions with 8-/16-/32-bit data
- **Fast instruction execution: 30 ns at 33 MHz**

MEMORY

- **128K single-cycle internal flash memory or ROM**
- **4K single-cycle internal RAM**

EXTERNAL BUS INTERFACE

- **16-MB linear external memory expansion**
- **Multiplexed 24-bit address/16-bit data bus**
- **Multiple bus mastership**
- **Programmable and external wait functions**
- **Idle state insertion for slow memory**

INTERRUPTS

- **31 maskable interrupts plus NMI**
- **Eight programmable priority levels on all interrupts and traps**

- **Specifiable rising and/or falling edge detection**
- **11 software traps**

PERIPHERALS

- **112 general-purpose, reassignable I/O pins**
- **Real-time pulse unit**
 - 24-bit multifunction timer: two channels
 - 16-bit timer/counters: five channels
 - 16-bit interval timer: one channel
- **8-bit, real-time output port: one channel**
- **Serial interface**
 - UART
 - Four clocked serial interfaces
 - I²C serial interface
 - Four dedicated baud rate generators
- **Clock generator**
 - Internal PLL (5x, 1x)
 - Direct clock input (¹/₂x)
- **Analog interface**
 - Sixteen-channel A/D converter with 8-bit resolution
 - Four-channel pulse-width modulator with 16-bit resolution

OTHER

- **Power saving features**
 - Halt/idle/stop modes
 - Clock output stop function
 - Fully static, 3V low-voltage operation

ORDERING INFORMATION

PART NUMBER	INTERNAL ROM	PACKAGE
μPD70F3008YGJ-33-8EU	128K flash EEPROM	144-pin plastic QFP (fine pitch), 20 mm x 20 mm
μPD703008YGJ-33-8EU	128K masked ROM	144-pin plastic QFP (fine pitch), 20 mm x 20 mm



For literature, call **1-800-366-9782** 7 a.m. to 6 p.m. Pacific time
or fax your request to **1-800-729-9288**
or visit our Web site at **www.nec.com**

© 1998 NEC Electronics Inc. NEC, V850 and V854 are either trademarks or registered trademarks of NEC Corporation in the United States and/or other countries. PC is a trademark of NV Philips. All other trademarks are the property of their respective owners. No part of this document may be copied or reproduced in any form or by any means without the prior written consent of NEC Electronics Inc. (NECEL). The information in this document is subject to change without notice. ALL DEVICES SOLD BY NECEL ARE COVERED BY THE PROVISIONS APPEARING IN NECEL TERMS AND CONDITIONS OF SALES ONLY, INCLUDING THE LIMITATION OF LIABILITY, WARRANTY, AND PATENT PROVISIONS. NECEL makes no warranty, express, statutory, implied, or by description, regarding information set forth herein or regarding the freedom of the described devices from patent infringement. NECEL assumes no responsibility for any errors that may appear in this document. NECEL makes no commitments to update or to keep current information contained in this document. The devices listed in this document are not suitable for use in applications such as, but not limited to, aircraft control systems, aerospace equipment, submarine cables, nuclear reactor control systems, and life-support systems. *Standard* quality grade devices are recommended for computers, office equipment, communication equipment, test and measurement equipment, machine tools, industrial robots, audio and visual equipment, and other consumer products. For automotive and transportation equipment, traffic control systems, and anti-disaster and anti-crime systems, it is recommended that the customer contact the responsible NECEL salesperson to determine the reliability requirements for any such application and any cost adder. NECEL does not recommend or approve use of any of its products in life-support devices or systems or in any application where failure could result in injury or death. If customers wish to use NECEL devices in applications not intended by NECEL, customers must contact the responsible NECEL salesperson to determine NECEL's willingness to support a given application.