

# MassPRO™ MP6101

## GPS production test turnkey solution

### KEY FEATURES

- GPS production test turnkey solution
- Highly automatic testing procedure
- Built-in high-precision GPS simulator
- Support multiple DUT connectivity (typ. 4 DUT)
- Firmware upgrading possible for various GPS chipset support
- Optional BT MAC address programming
- PXI platform eases the combined test by adding various functions of PXI cards

### OVERVIEW

The MP6101 is a highly automatic GPS production test turnkey solution. It equips a ultra-high-precision GPS simulator which provides a stable and accurate signal for GPS receivers testing. With the help of built-in test firmware, the MP6101 enables manufacturers to easily perform the product verification testing on the GPS PCBA.

In addition to test automation, the MP6101 also supports multiple DUT connectivity to further increase the production test efficiency. With the help of the integrated testing software, the users need only one click on the test button then the MP6101 will do all the corresponding testing item(s) specified, indicate the testing progress, display the result and log the report file automatically. Besides, BT MAC address programming feature can be optionally upgraded to help the customers who involve in BT+GPS related production.

With the high integration and automation, the MP6101 is very suitable for those customers who require a low cost and high performance production test solution.

### SETUP ARCHITECTURE

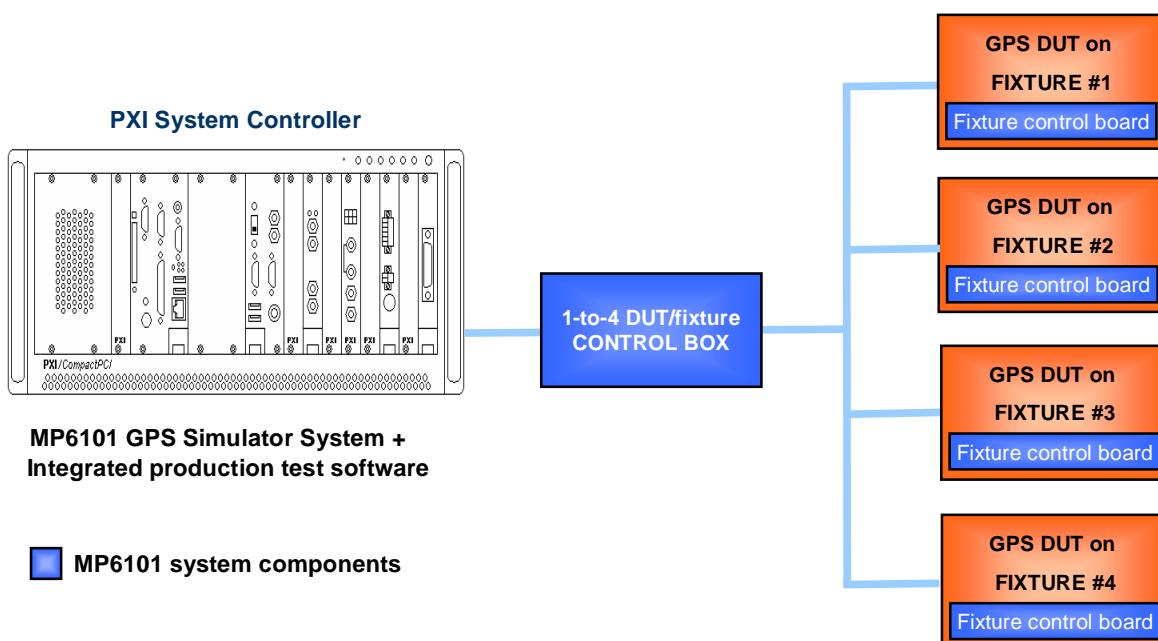

## SPECIFICATION

### Output Frequency

- L1 1575.42MHz

### Frequency accuracy

- +/- 0.01ppm

### Phase Modulation

- BPSK

### Channel

- Single channel 1 to 32 selectable

### NAV Data

- GPS C/A @1.023MHz with 50 bps fixed-pattern data

### Output RF Level (Nominal)

- -85 dBm to -135 dBm in 1 dB step

### RF control

- ON/OFF/CW

### RF connector

- SMA type

### Master Oscillator

- Frequency:  
10.23MHz
- Thermal stability:  
0.02ppm @ -30 ~ +70°C
- Aging:  
0.1ppm/yr (0.001ppm/day)
- Phase noise:  
-85dBc/Hz @1Hz  
-140dBc/Hz @100Hz  
-150dBc/Hz @10KHz
- Short-term stability:  
1.0E-011 @ 1 sec  
0.0E+000 @ 10 secs

### System Specification

- System  
OS: Microsoft® Windows® XP  
CPU: Celeron® / Pentium® M  
Chipset: Intel® 855GME + ICH4  
Input: 100-240VAC  
Size: 257.1x177x212.8mm (W x H x D)  
Weight: 5Kg
- Environment:  
Operating temperature: 0 ~ +50°C  
Storage temperature : -20 ~ +70°C



### System Design Center

#### Asian Information Technology Group

詮鼎事業群技術中心

[www.aitgroup.com.tw](http://www.aitgroup.com.tw)

#### Taiwan

台北市內湖區瑞光路441號3樓  
3F, No.441, Ruei-Guang Road, Neihu,  
Taipei, Taiwan

Tel: +886-2-87978997

Fax:+886-2-87977388

Email: [michael.chen@aitgroup.com.tw](mailto:michael.chen@aitgroup.com.tw)

#### Shenzhen

深圳市福華三路深国际商会中心13樓(新  
国际会展中心旁边)

13F, Fuhua 3 Road, Shenzhen P. R.  
518028

Tel : +86-755-8831-3166

Fax: +86-755-8331-2366

Email: [alex.jiang@apachecomm.com.cn](mailto:alex.jiang@apachecomm.com.cn)

#### Shanghai

上海市淮海西路55号申通信息廣場12樓G  
座

Room 12G, Sun Tong Infoport Plaza,  
No.55, Huaihai West Road , Shanghai  
China 200030

Tel : +86-21-52989847

Fax: +86-21-52989027

#### Beijing

北京市建国门外大街甲24号东海中心  
1001室

Room1001, East Ocean Centre, No.24A  
Jianguomenwai Street , Chaoyang  
District, Beijing 100004, P.R. China

Tel : +86-10-6515-5711

Fax: +86-10-6515-6190

#### Singapore

16 New Industrial Road #03-10 Hudson  
TechnoCentre Singapore 536204

Tel : +65-64880637

Email: [Damian.Lee@ait-aitg.com](mailto:Damian.Lee@ait-aitg.com)

#### Korea

7F Newai Bldg, 981-3, Kwanyang-Dong,  
Dongan-Ku Anyang-Si, Kyungki-Do,  
South Korea 431-060

Tel : +82-31-442-1818

Email: [john@www.DataSheet4U.com](mailto:john@www.DataSheet4U.com)