

Features

- Backscatter-based UHF RFID IC (860 Mhz to 960 Mhz) Supporting Current and Future Radio Regulations
- Support for All Data Structures Defined in ISO/IEC 18000-6, ISO/IEC 15961, ISO/IEC 15963, GTAG, ePC
- ATA5590 is a Passive Backscatter-communication-based Data Carrier IC
 - 12 μ W RF Power Required for Minimum Communication Feasibility
- Programming of the Memory Possible in Atomic and Global Mode
 - Dynamic Programming Time Management
 - Programming Range: 80% of the Read Space
- Programmable EAS Functionality
- Double-edge PIE Encoding
- Short, Long and Temporary Commands
- PSK for the Backscatter Data Stream to Achieve Highest SNR
- Full-duplex and Half-duplex Communication Modes
- Synchronous Return Link to Achieve Highest SNR
- ATA5590 Enables Several Closed-loop Possibilities to Enable:
 - Adaptive Speed During Read and Anticollision Procedures
 - Fast Programming
- Communication Speed 5 Kbit/s to 60 Kbit/s, Fully Controlled by the Reader
 - Different Speed Factors Possible in Forward and Return Link
- Two Kinds of Anticollision Procedures Implemented
 - Deterministic and Slotted Aloha Anticollision Procedure
 - Group_Selection Commands Supporting = < > Decisions
 - Wakeup Commands
 - All Procedures Support 16-Bit Random Values for Access Control Mechanisms
- No Unique Data Structures are Needed to Enable Both Anticollision Procedures
 - Parallel Handling of Different Structures and Opening of Migration Paths for Private Structures
 - Applications in Open Data Systems as well as in Closed Systems
 - Maximum ID is Limited Only by the User Memory Space (1024 Bits + 256 Bits)
- Both Procedures Also Support Virgin-tag Initialization During Anticollision
- High-efficiency Commands to Increase and Adapt Anticollision Speed



1-kbit UHF R/W IDIC[®] with Anti-collision Function

ATA5590 TAGIDU[™]

Summary

Preliminary

1. Overview

ATA5590 is a wireless data carrier IC. The IC is powered by the RF field transmitted by an RFID reader. The carrier frequency is typically in the UHF region (860 MHz to 960 MHz).

The functionality of the IC is controlled by the reader.

The IC backscatters the required information back to the reader using a backscatter modulation technique; it is a passive UHF Transponder device based on the experience of the EU-funded project Palomar (IST1999-10339).

ATA5590 was created to enable applications for open data management systems also supporting old or private data structures.

Rev. 4817DS-RFID-12/05



Note: This is a summary document. A complete document is available under NDA. For more information, please contact your local Atmel sales office.

2. The Structure of ATA5590

Figure 2-1. Structure of ATA5590

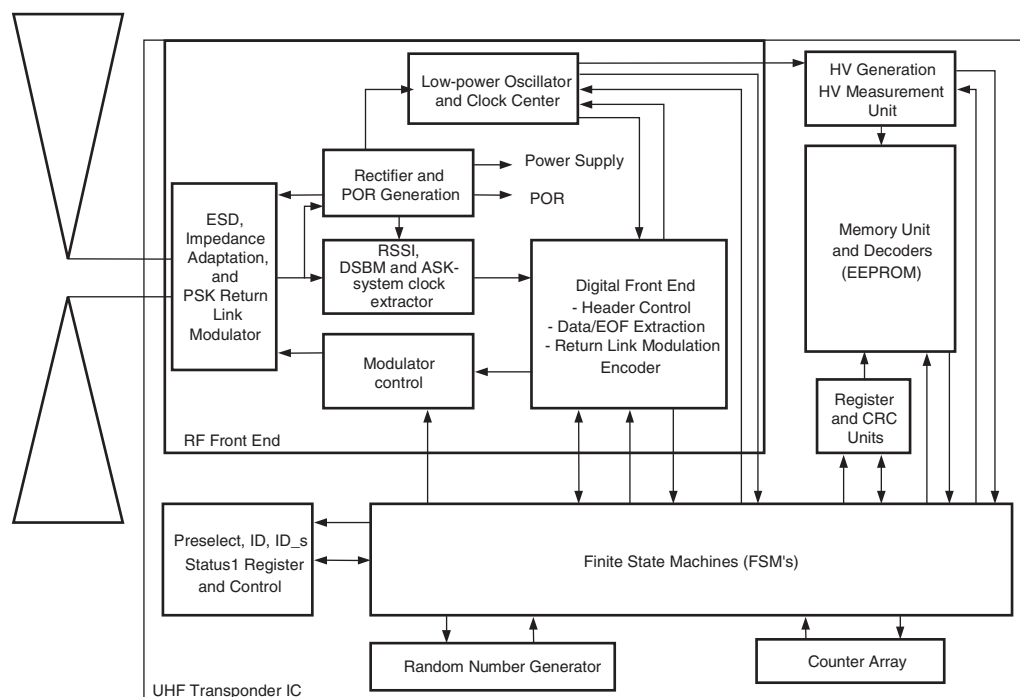

ATA5590 contains the following top level blocks:

- The analog front end, which extracts
 - the supply voltage for the IC from the RF beam
 - the modulation dips transmitted by the reader
 - the control signals indicating the status of the power supply
- The analog front end also contains structures for ESD protection, a low-power oscillator, and a modulator stage.
- The digital front end, which extract status signals of the link as well as the extracted symbols
- A memory block which is implemented as an EEPROM containing an on chip HV voltage generator to program the memory
- A register unit, which contains the transmitted commands and parameters
- A main finite state machine (FSM), which controls the frond end and the access mechanism.
- A random number generator, which is used to generate random values for the Aloha and tree-walker-based anticollision procedures.
- Three different persistent nodes, which are able to store the status of the anticollision routine over a certain time without any external power.

Please refer to the Application Note “Antenna Matching”.

3. Ordering Information

Extended Type Number	Package	Remarks
ATA559001-DBW	6" Wafer	15 µm NiAu bumps, 300 µm wafer thickness
ATA559001-6DSY	TSSOP10	For development of tag antenna designs, Pb-free

4. Package Information

Package: TSSOP 10
 (acc. to JEDEC Standard MO-187)

Dimensions in mm
 Not indicated tolerances ± 0.05

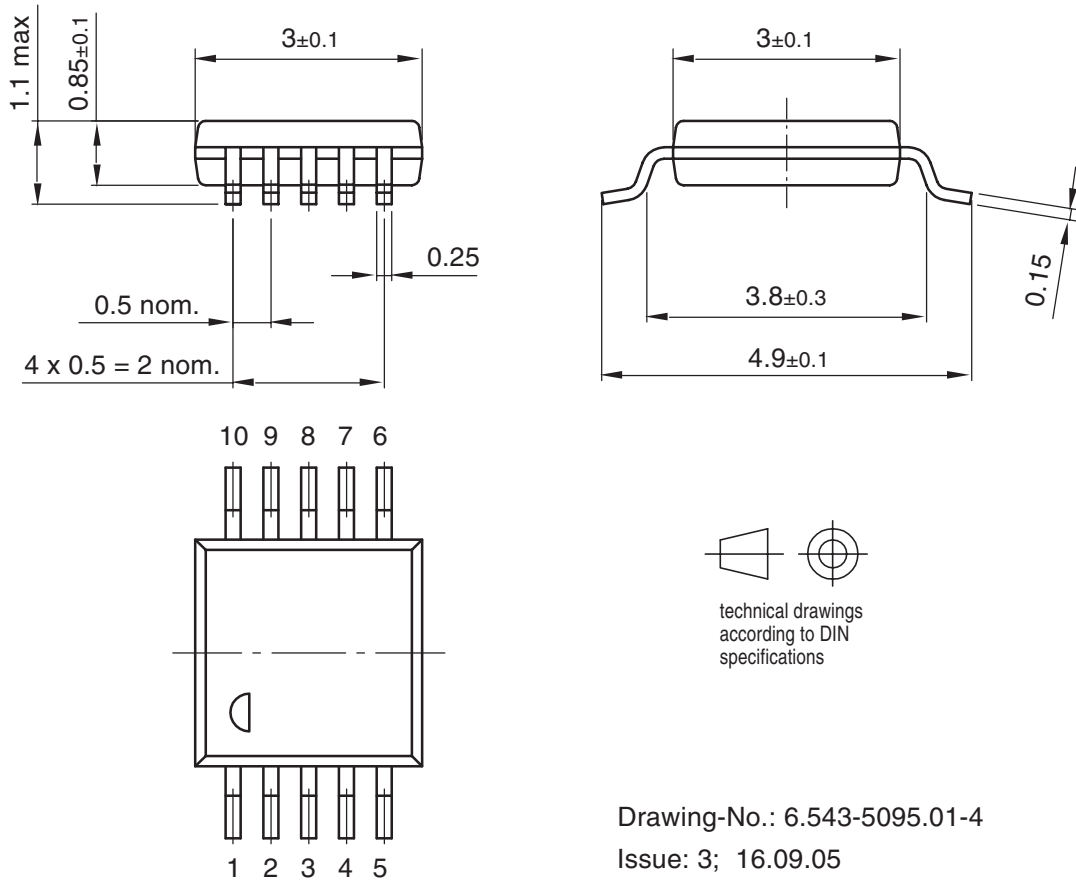



Atmel Corporation

2325 Orchard Parkway
San Jose, CA 95131, USA
Tel: 1(408) 441-0311
Fax: 1(408) 487-2600

Regional Headquarters

Europe

Atmel Sarl
Route des Arsenaux 41
Case Postale 80
CH-1705 Fribourg
Switzerland
Tel: (41) 26-426-5555
Fax: (41) 26-426-5500

Asia

Room 1219
Chinachem Golden Plaza
77 Mody Road Tsimshatsui
East Kowloon
Hong Kong
Tel: (852) 2721-9778
Fax: (852) 2722-1369

Japan

9F, Tonetsu Shinkawa Bldg.
1-24-8 Shinkawa
Chuo-ku, Tokyo 104-0033
Japan
Tel: (81) 3-3523-3551
Fax: (81) 3-3523-7581

Atmel Operations

Memory

2325 Orchard Parkway
San Jose, CA 95131, USA
Tel: 1(408) 441-0311
Fax: 1(408) 436-4314

Microcontrollers

2325 Orchard Parkway
San Jose, CA 95131, USA
Tel: 1(408) 441-0311
Fax: 1(408) 436-4314

La Chantrerie
BP 70602
44306 Nantes Cedex 3, France
Tel: (33) 2-40-18-18-18
Fax: (33) 2-40-18-19-60

ASIC/ASSP/Smart Cards

Zone Industrielle
13106 Rousset Cedex, France
Tel: (33) 4-42-53-60-00
Fax: (33) 4-42-53-60-01

1150 East Cheyenne Mtn. Blvd.
Colorado Springs, CO 80906, USA
Tel: 1(719) 576-3300
Fax: 1(719) 540-1759

Scottish Enterprise Technology Park
Maxwell Building
East Kilbride G75 0QR, Scotland
Tel: (44) 1355-803-000
Fax: (44) 1355-242-743

RF/Automotive

Theresienstrasse 2
Postfach 3535
74025 Heilbronn, Germany
Tel: (49) 71-31-67-0
Fax: (49) 71-31-67-2340

1150 East Cheyenne Mtn. Blvd.
Colorado Springs, CO 80906, USA
Tel: 1(719) 576-3300
Fax: 1(719) 540-1759

Biometrics/Imaging/Hi-Rel MPU/ High Speed Converters/RF Datacom

Avenue de Rochepleine
BP 123
38521 Saint-Egreve Cedex, France
Tel: (33) 4-76-58-30-00
Fax: (33) 4-76-58-34-80

Literature Requests

www.atmel.com/literature

Disclaimer: The information in this document is provided in connection with Atmel products. No license, express or implied, by estoppel or otherwise, to any intellectual property right is granted by this document or in connection with the sale of Atmel products. **EXCEPT AS SET FORTH IN ATMEL'S TERMS AND CONDITIONS OF SALE LOCATED ON ATMEL'S WEB SITE, ATMEL ASSUMES NO LIABILITY WHATSOEVER AND DISCLAIMS ANY EXPRESS, IMPLIED OR STATUTORY WARRANTY RELATING TO ITS PRODUCTS INCLUDING, BUT NOT LIMITED TO, THE IMPLIED WARRANTY OF MERCHANTABILITY, FITNESS FOR A PARTICULAR PURPOSE, OR NON-INFRINGEMENT. IN NO EVENT SHALL ATMEL BE LIABLE FOR ANY DIRECT, INDIRECT, CONSEQUENTIAL, PUNITIVE, SPECIAL OR INCIDENTAL DAMAGES (INCLUDING, WITHOUT LIMITATION, DAMAGES FOR LOSS OF PROFITS, BUSINESS INTERRUPTION, OR LOSS OF INFORMATION) ARISING OUT OF THE USE OR INABILITY TO USE THIS DOCUMENT, EVEN IF ATMEL HAS BEEN ADVISED OF THE POSSIBILITY OF SUCH DAMAGES.** Atmel makes no representations or warranties with respect to the accuracy or completeness of the contents of this document and reserves the right to make changes to specifications and product descriptions at any time without notice. Atmel does not make any commitment to update the information contained herein. Unless specifically provided otherwise, Atmel products are not suitable for, and shall not be used in, automotive applications. Atmel's products are not intended, authorized, or warranted for use as components in applications intended to support or sustain life.

© Atmel Corporation 2005. All rights reserved. Atmel®, logo and combinations thereof, Everywhere You Are®, IDIC®, and others, are registered trademarks, TAGIDU™ and others are trademarks of Atmel Corporation or its subsidiaries. Other terms and product names may be trademarks of others.



Printed on recycled paper.

4817DS-RFID-12/05