

## 1K 5.0V I<sup>2</sup>C™ Serial EEPROM

### FEATURES

- Single supply with operation from 4.5 to 5.5V
- Low power CMOS technology
  - 1 mA active current typical
  - 10 µA standby current typical at 5.5V
- Organized as a single block of 128 bytes (128 x 8)
- 2-wire serial interface bus, I<sup>2</sup>C compatible
- 100 kHz and 400 kHz compatibility
- Page-write buffer for up to 16 bytes
- Self-timed write cycle (including auto-erase)
- Fast 1 mS write cycle time for byte or page mode
- Address lines allow up to eight devices on bus
- 1,000,000 erase/write cycles guaranteed
- ESD protection > 4,000V
- Data retention > 200 years
- 8-pin PDIP, SOIC or TSSOP packages
  - Commercial (C): 0°C to +70°C
  - Industrial (I): -40°C to +85°C
  - Automotive (E): -40°C to +125°C
- Available for extended temperature ranges

### DESCRIPTION

The Microchip Technology Inc. 24C01C is a 1K bit Serial Electrically Erasable PROM with a voltage range of 4.5V to 5.5V. The device is organized as a single block of 128 x 8-bit memory with a 2-wire serial interface. Low current design permits operation with typical standby and active currents of only 10 µA and 1 mA respectively. The device has a page-write capability for up to 16 bytes of data and has fast write cycle times of only 1 mS for both byte and page writes. Functional address lines allow the connection of up to eight 24C01C devices on the same bus for up to 8K bits of contiguous EEPROM memory. The device is available in the standard 8-pin PDIP, 8-pin SOIC (150 mil), and TSSOP packages.

### PACKAGE TYPES

#### PDIP/SOIC

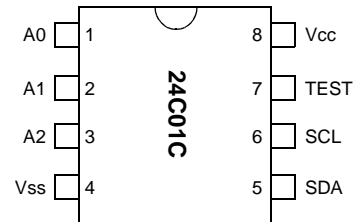

#### TSSOP

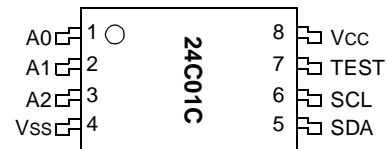

### BLOCK DIAGRAM

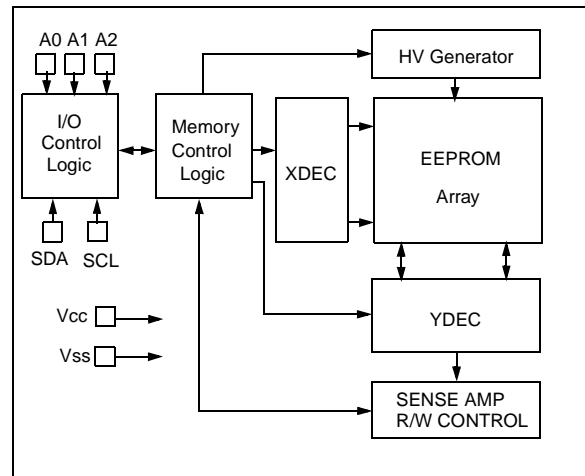

# 24C01C

## 1.0 ELECTRICAL CHARACTERISTICS

### 1.1 Maximum Ratings\*

VCC.....7.0V  
 All inputs and outputs w.r.t. Vss .....-0.6V to Vcc +1.0V  
 Storage temperature .....-65°C to +150°C  
 Ambient temp. with power applied.....-65°C to +125°C  
 Soldering temperature of leads (10 seconds) .. +300°C  
 ESD protection on all pins ..... ≥ 4 kV

**\*Notice:** Stresses above those listed under "Maximum ratings" may cause permanent damage to the device. This is a stress rating only and functional operation of the device at those or any other conditions above those indicated in the operational listings of this specification is not implied. Exposure to maximum rating conditions for extended periods may affect device reliability.

**TABLE 1-1: PIN FUNCTION TABLE**

Name	Function
Vss	Ground
SDA	Serial Data
SCL	Serial Clock
Vcc	+4.5V to 5.5V Power Supply
A0, A1, A2	Chip Selects
Test	Test Pin: may be tied high, low or left floating

**TABLE 1-2: DC CHARACTERISTICS**

Parameter	Symbol	Min.	Max.	Units	Conditions
VCC = +4.5V to +5.5V Commercial (C): Tamb = 0°C to +70°C Industrial (I): Tamb = -40°C to +85°C Automotive (E): Tamb = -40°C to +125°C					
SCL and SDA pins:					
High level input voltage	V <sub>IH</sub>	0.7 V <sub>CC</sub>		V	
Low level input voltage	V <sub>IL</sub>		.3 V <sub>CC</sub>	V	
Hysteresis of Schmitt trigger inputs	V <sub>HYS</sub>	0.05 V <sub>CC</sub>	—	V	(Note)
Low level output voltage	V <sub>OL</sub>		.40	V	I <sub>OL</sub> = 3.0 mA, V <sub>CC</sub> = 4.5V
Input leakage current	I <sub>LI</sub>	-10	10	µA	V <sub>IN</sub> = 0.1V to 5.5V, WP = V <sub>ss</sub>
Output leakage current	I <sub>LO</sub>	-10	10	µA	V <sub>OUT</sub> = 0.1V to 5.5V
Pin capacitance (all inputs/outputs)	C <sub>IN</sub> , C <sub>OUT</sub>	—	10	pF	V <sub>CC</sub> = 5.0V (Note) Tamb = 25°C, f = 1 MHz
Operating current	I <sub>CC</sub> Read	—	1	mA	V <sub>CC</sub> = 5.5V, SCL = 400 kHz
	I <sub>CC</sub> Write	—	3	mA	V <sub>CC</sub> = 5.5V
Standby current	I <sub>CCS</sub>	—	50	µA	V <sub>CC</sub> = 5.5V, SDA = SCL = V <sub>CC</sub> WP = V <sub>ss</sub>

**Note:** This parameter is periodically sampled and not 100% tested.

**TABLE 1-3: AC CHARACTERISTICS**

Parameter		Tamb > +85°C		-40°C ≤ Tamb ≤ +85°C		Units	Remarks
		Min.	Max.	Min.	Max.		
All parameters apply across the specified operating ranges unless otherwise noted.		Vcc = 4.5V to 5.5V Commercial (C): Tamb = 0°C to +70°C Industrial (I): Tamb = -40°C to +85°C Automotive (E): Tamb = -40°C to +125°C					
Clock frequency	FCLK	—	100	—	400	kHz	
Clock high time	THIGH	4000	—	600	—	ns	
Clock low time	TLOW	4700	—	1300	—	ns	
SDA and SCL rise time	TR	—	1000	—	300	ns	(Note 1)
SDA and SCL fall time	TF	—	300	—	300	ns	(Note 1)
START condition hold time	THD:STA	4000	—	600	—	ns	After this period the first clock pulse is generated
START condition setup time	TSU:STA	4700	—	600	—	ns	Only relevant for repeated START condition
Data input hold time	THD:DAT	0	—	0	—	ns	(Note 2)
Data input setup time	TSU:DAT	250	—	100	—	ns	
STOP condition setup time	TSU:STO	4000	—	600	—	ns	
Output valid from clock	TAA	—	3500	—	900	ns	(Note 2)
Bus free time	TBUF	4700	—	1300	—	ns	Time the bus must be free before a new transmission can start
Output fall time from VIH minimum to VIL maximum	TOF	—	250	20 + 0.1 CB	250	ns	(Note 1), CB ≤ 100 pF
Input filter spike suppression (SDA and SCL pins)	TSP	—	50	—	50	ns	(Note 3)
Write cycle time	TWR	—	1.5	—	1	ms	Byte or Page mode
Endurance		1M	—	1M	—	cycles	25°C, Vcc = 5.0V, Block Mode (Note 4)

- Note 1:** Not 100% tested. CB = total capacitance of one bus line in pF.
- 2:** As a transmitter, the device must provide an internal minimum delay time to bridge the undefined region (minimum 300 ns) of the falling edge of SCL to avoid unintended generation of START or STOP conditions.
- 3:** The combined TSP and VHYS specifications are due to Schmitt trigger inputs which provide improved noise spike suppression. This eliminates the need for a TI specification for standard operation.
- 4:** This parameter is not tested but guaranteed by characterization. For endurance estimates in a specific application, please consult the Total Endurance Model which can be obtained on our website.

**FIGURE 1-1: BUS TIMING DATA**

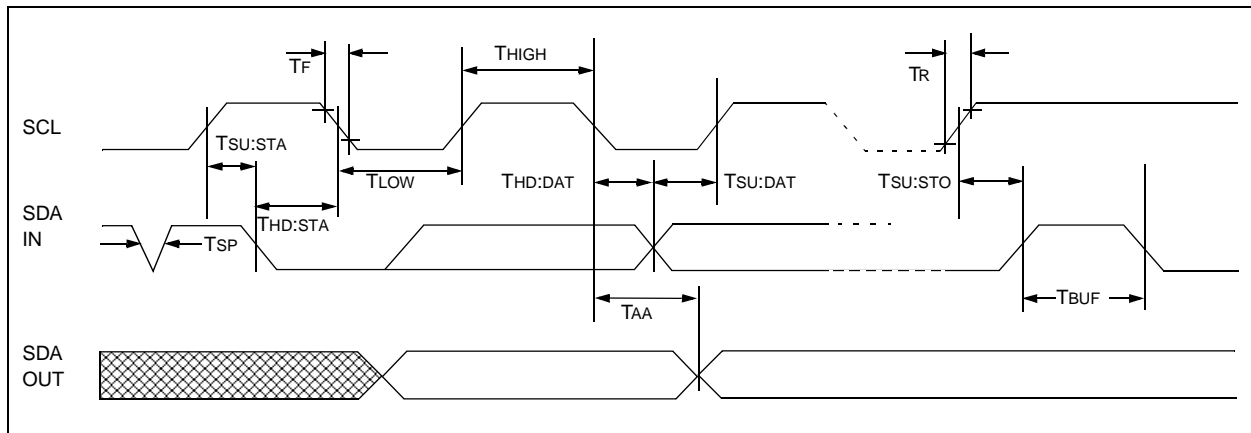

## 2.0 PIN DESCRIPTIONS

### 2.1 SDA Serial Data

This is a bi-directional pin used to transfer addresses and data into and data out of the device. It is an open drain terminal, therefore the SDA bus requires a pull-up resistor to Vcc (typical 10 k $\Omega$  for 100 kHz, 2 k $\Omega$  for 400 kHz).

For normal data transfer SDA is allowed to change only during SCL low. Changes during SCL high are reserved for indicating the START and STOP conditions.

### 2.2 SCL Serial Clock

This input is used to synchronize the data transfer from and to the device.

### 2.3 A0, A1, A2

The levels on these inputs are compared with the corresponding bits in the slave address. The chip is selected if the compare is true.

Up to eight 24C01C devices may be connected to the same bus by using different chip select bit combinations. These inputs must be connected to either Vcc or Vss.

### 2.4 Test

This pin is utilized for testing purposes only. It may be tied high, tied low or left floating.

### 2.5 Noise Protection

The 24C01C employs a Vcc threshold detector circuit which disables the internal erase/write logic if the Vcc is below 3.8 volts at nominal conditions.

The SCL and SDA inputs have Schmitt trigger and filter circuits which suppress noise spikes to assure proper device operation even on a noisy bus.

## 3.0 FUNCTIONAL DESCRIPTION

The 24C01C supports a bi-directional 2-wire bus and data transmission protocol. A device that sends data onto the bus is defined as transmitter, and a device receiving data as receiver. The bus has to be controlled by a master device which generates the serial clock (SCL), controls the bus access, and generates the START and STOP conditions, while the 24C01C works as slave. Both master and slave can operate as transmitter or receiver but the master device determines which mode is activated.

## 4.0 BUS CHARACTERISTICS

The following **bus protocol** has been defined:

- Data transfer may be initiated only when the bus is not busy.
- During data transfer, the data line must remain stable whenever the clock line is HIGH. Changes in the data line while the clock line is HIGH will be interpreted as a START or STOP condition.

Accordingly, the following bus conditions have been defined (Figure 4-1).

### 4.1 Bus not Busy (A)

Both data and clock lines remain HIGH.

### 4.2 Start Data Transfer (B)

A HIGH to LOW transition of the SDA line while the clock (SCL) is HIGH determines a START condition. All commands must be preceded by a START condition.

### 4.3 Stop Data Transfer (C)

A LOW to HIGH transition of the SDA line while the clock (SCL) is HIGH determines a STOP condition. All operations must be ended with a STOP condition.

### 4.4 Data Valid (D)

The state of the data line represents valid data when, after a START condition, the data line is stable for the duration of the HIGH period of the clock signal.

The data on the line must be changed during the LOW period of the clock signal. There is one bit of data per clock pulse.

Each data transfer is initiated with a START condition and terminated with a STOP condition. The number of the data bytes transferred between the START and STOP conditions is determined by the master device and is theoretically unlimited, although only the last sixteen will be stored when doing a write operation. When an overwrite does occur it will replace data in a first in first out fashion.

### 4.5 Acknowledge

Each receiving device, when addressed, is required to generate an acknowledge after the reception of each byte. The master device must generate an extra clock pulse which is associated with this acknowledge bit.

**Note:** The 24C01C does not generate any acknowledge bits if an internal programming cycle is in progress.

The device that acknowledges has to pull down the SDA line during the acknowledge clock pulse in such a way that the SDA line is stable LOW during the HIGH period of the acknowledge related clock pulse. Of course, setup and hold times must be taken into account. A master must signal an end of data to the slave by not generating an acknowledge bit on the last byte that has been clocked out of the slave. In this case, the slave must leave the data line HIGH to enable the master to generate the STOP condition (Figure 4-2).

**FIGURE 4-1: DATA TRANSFER SEQUENCE ON THE SERIAL BUS CHARACTERISTICS**

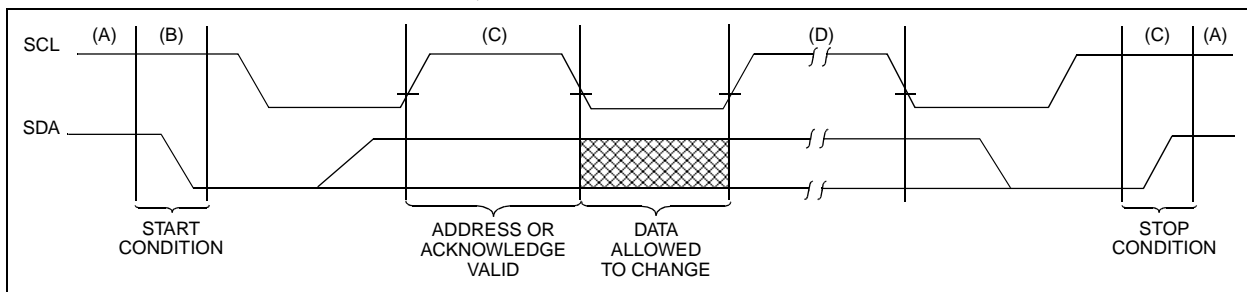

**FIGURE 4-2: ACKNOWLEDGE TIMING**

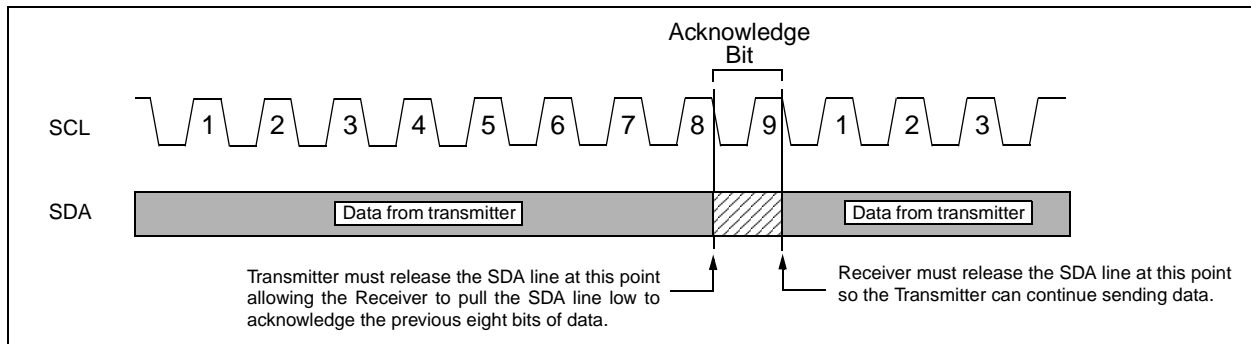

## 5.0 DEVICE ADDRESSING

A control byte is the first byte received following the start condition from the master device (Figure 5-1). The control byte consists of a four bit control code; for the 24C01C this is set as 1010 binary for read and write operations. The next three bits of the control byte are the chip select bits (A2, A1, A0). The chip select bits allow the use of up to eight 24C01C devices on the same bus and are used to select which device is accessed. The chip select bits in the control byte must correspond to the logic levels on the corresponding A2, A1, and A0 pins for the device to respond. These bits are in effect the three most significant bits of the word address.

The last bit of the control byte defines the operation to be performed. When set to a one a read operation is selected, and when set to a zero a write operation is selected. Following the start condition, the 24C01C monitors the SDA bus checking the control byte being transmitted. Upon receiving a 1010 code and appropriate chip select bits, the slave device outputs an acknowledge signal on the SDA line. Depending on the state of the R/W bit, the 24C01C will select a read or write operation.

FIGURE 5-1: CONTROL BYTE FORMAT

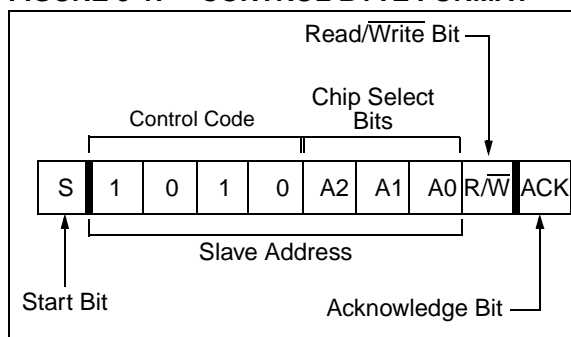

### 5.1 Contiguous Addressing Across Multiple Devices

The chip select bits A2, A1, A0 can be used to expand the contiguous address space for up to 8K bits by adding up to eight 24C01C devices on the same bus. In this case, software can use A0 of the control byte as address bit A8, A1 as address bit A9, and A2 as address bit A10. It is not possible to write or read across device boundaries.

## 6.0 WRITE OPERATIONS

### 6.1 Byte Write

Following the start signal from the master, the device code (4 bits), the chip select bits (3 bits), and the R/W bit which is a logic low is placed onto the bus by the master transmitter. The device will acknowledge this control byte during the ninth clock pulse. The next byte transmitted by the master is the word address and will be written into the address pointer of the 24C01C. After receiving another acknowledge signal from the 24C01C the master device will transmit the data word to be written into the addressed memory location. The 24C01C acknowledges again and the master generates a stop condition. This initiates the internal write cycle, and during this time the 24C01C will not generate acknowledge signals (Figure 6-1).

### 6.2 Page Write

The write control byte, word address and the first data byte are transmitted to the 24C01C in the same way as in a byte write. But instead of generating a stop condition, the master transmits up to 15 additional data bytes to the 24C01C which are temporarily stored in the on-chip page buffer and will be written into the memory after the master has transmitted a stop condition. After the receipt of each word, the four lower order address

pointer bits are internally incremented by one. The higher order four bits of the word address remains constant. If the master should transmit more than 16 bytes prior to generating the stop condition, the address counter will roll over and the previously received data will be overwritten. As with the byte write operation, once the stop condition is received an internal write cycle will begin (Figure 6-2).

**Note:** Page write operations are limited to writing bytes within a single physical page, regardless of the number of bytes actually being written. Physical page boundaries start at addresses that are integer multiples of the page buffer size (or 'page size') and end at addresses that are integer multiples of [page size - 1]. If a page write command attempts to write across a physical page boundary, the result is that the data wraps around to the beginning of the current page (overwriting data previously stored there), instead of being written to the next page as might be expected. It is therefore necessary for the application software to prevent page write operations that would attempt to cross a page boundary.

**FIGURE 6-1: BYTE WRITE**

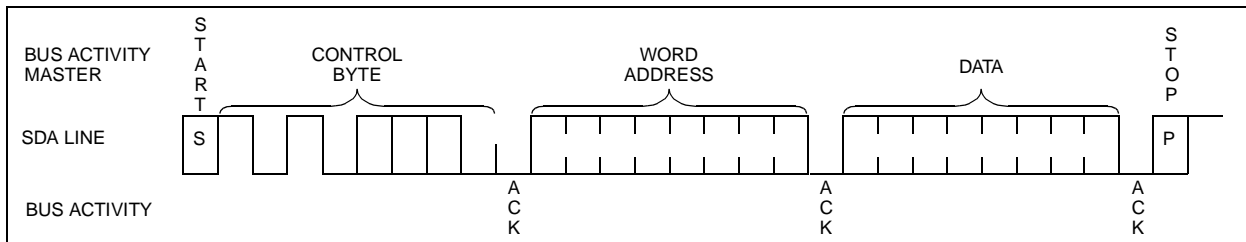

**FIGURE 6-2: PAGE WRITE**

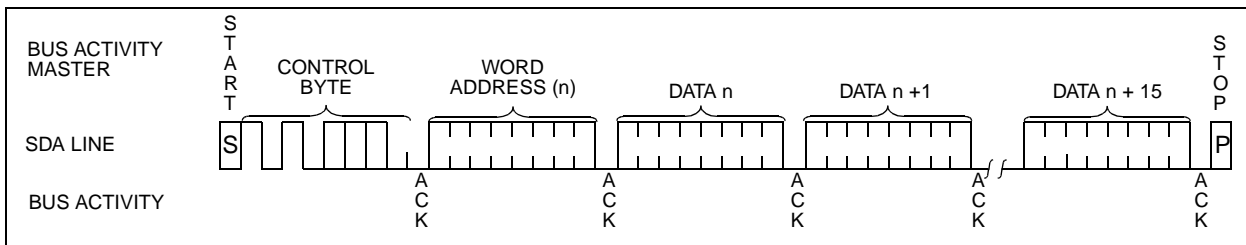

## 7.0 ACKNOWLEDGE POLLING

Since the device will not acknowledge during a write cycle, this can be used to determine when the cycle is complete (this feature can be used to maximize bus throughput). Once the stop condition for a write command has been issued from the master, the device initiates the internally timed write cycle. ACK polling can be initiated immediately. This involves the master sending a start condition followed by the control byte for a write command ( $R/\overline{W} = 0$ ). If the device is still busy with the write cycle, then no ACK will be returned. If no ACK is returned, then the start bit and control byte must be re-sent. If the cycle is complete, then the device will return the ACK and the master can then proceed with the next read or write command. See Figure 7-1 for flow diagram.

FIGURE 7-1: ACKNOWLEDGE POLLING FLOW

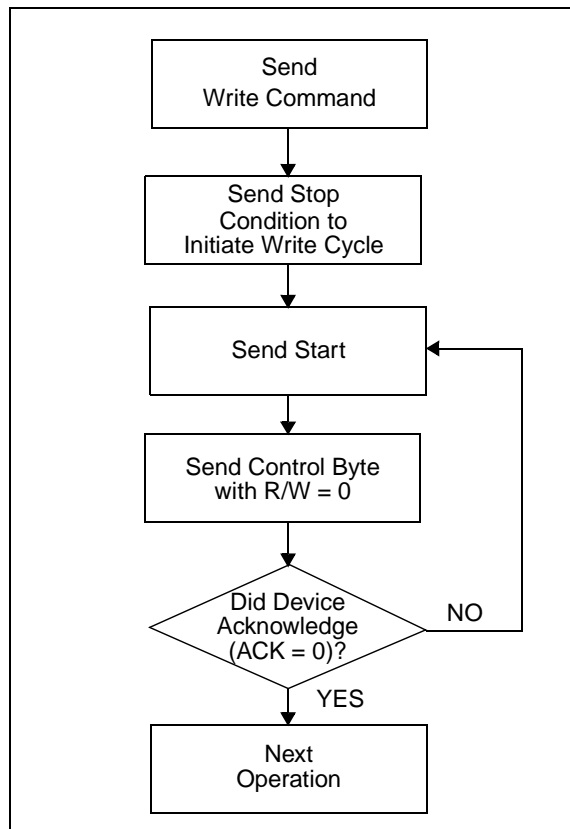



## 8.0 READ OPERATIONS

Read operations are initiated in the same way as write operations with the exception that the  $R/\bar{W}$  bit of the slave address is set to one. There are three basic types of read operations: current address read, random read, and sequential read.

### 8.1 Current Address Read

The 24C01C contains an address counter that maintains the address of the last word accessed, internally incremented by one. Therefore, if the previous read access was to address  $n$ , the next current address read operation would access data from address  $n + 1$ . Upon receipt of the slave address with the  $R/\bar{W}$  bit set to one, the 24C01C issues an acknowledge and transmits the eight bit data word. The master will not acknowledge the transfer but does generate a stop condition and the 24C01C discontinues transmission (Figure 8-1).

### 8.2 Random Read

Random read operations allow the master to access any memory location in a random manner. To perform this type of read operation, first the word address must be set. This is done by sending the word address to the 24C01C as part of a write operation. After the word

address is sent, the master generates a start condition following the acknowledge. This terminates the write operation, but not before the internal address pointer is set. Then the master issues the control byte again but with the  $R/\bar{W}$  bit set to a one. The 24C01C will then issue an acknowledge and transmits the eight bit data word. The master will not acknowledge the transfer but does generate a stop condition and the 24C01C discontinues transmission (Figure 8-2). After this command, the internal address counter will point to the address location following the one that was just read.

### 8.3 Sequential Read

Sequential reads are initiated in the same way as a random read except that after the 24C01C transmits the first data byte, the master issues an acknowledge as opposed to a stop condition in a random read. This directs the 24C01C to transmit the next sequentially addressed 8-bit word (Figure 8-3).

To provide sequential reads the 24C01C contains an internal address pointer which is incremented by one at the completion of each operation. This address pointer allows the entire memory contents to be serially read during one operation. The internal address pointer will automatically roll over from address 7F to address 00.

**FIGURE 8-1: CURRENT ADDRESS READ**

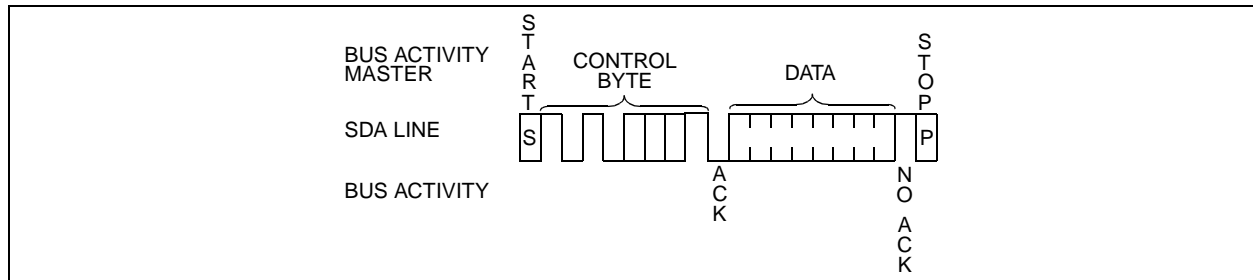

**FIGURE 8-2: RANDOM READ**

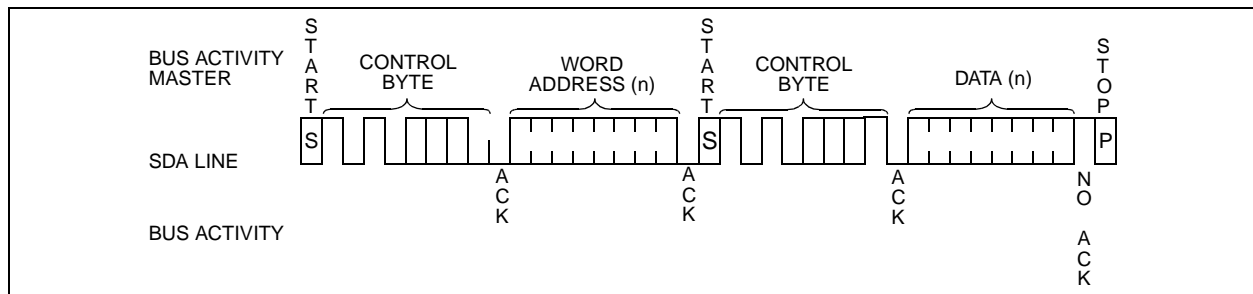

**FIGURE 8-3: SEQUENTIAL READ**

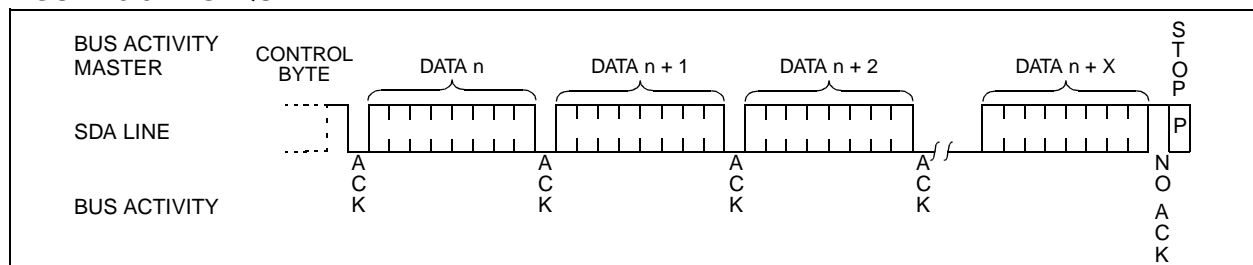

NOTES:

## 24C01C PRODUCT IDENTIFICATION SYSTEM

To order or obtain information, e.g., on pricing or delivery, refer to the factory or the listed sales office.

<b>24C01C</b> —	<b>/P</b>	
		<b>Package:</b>
		P = Plastic DIP (300 mil Body), 8-lead
		SN = Plastic SOIC, (150 mil Body), 8-lead
		ST = TSSOP (4.4 mm Body), 8-lead
		<b>Temperature Range:</b>
		Blank = 0°C to +70°C
		I = -40°C to +85°C
		E = -40°C to +125°C
		<b>Device:</b>
		24C01C 1K I <sup>2</sup> C Serial EEPROM
		24C01CT 1K I <sup>2</sup> C Serial EEPROM (Tape and Reel)

### Sales and Support

#### Data Sheets

Products supported by a preliminary Data Sheet may have an errata sheet describing minor operational differences and recommended workarounds. To determine if an errata sheet exists for a particular device, please contact one of the following:

1. Your local Microchip sales office
2. The Microchip Corporate Literature Center U.S. FAX: (602) 786-7277
3. The Microchip Worldwide Site ([www.microchip.com](http://www.microchip.com))

Please specify which device, revision of silicon and Data Sheet (include Literature #) you are using.

#### New Customer Notification System

4. Register on our web site ([www.microchip.com/cn](http://www.microchip.com/cn)) to receive the most current information on our products.



# MICROCHIP

## WORLDWIDE SALES AND SERVICE

### AMERICAS

#### Corporate Office

2355 West Chandler Blvd.  
Chandler, AZ 85224-6199  
Tel: 480-792-7200 Fax: 480-792-7277  
Technical Support: 480-792-7627  
Web Address: <http://www.microchip.com>

#### Rocky Mountain

2355 West Chandler Blvd.  
Chandler, AZ 85224-6199  
Tel: 480-792-7966 Fax: 480-792-7456

#### Atlanta

500 Sugar Mill Road, Suite 200B  
Atlanta, GA 30350  
Tel: 770-640-0034 Fax: 770-640-0307

#### Boston

2 Lan Drive, Suite 120  
Westford, MA 01886  
Tel: 978-692-3848 Fax: 978-692-3821

#### Chicago

333 Pierce Road, Suite 180  
Itasca, IL 60143  
Tel: 630-285-0071 Fax: 630-285-0075

#### Dallas

4570 Westgrove Drive, Suite 160  
Addison, TX 75001  
Tel: 972-818-7423 Fax: 972-818-2924

#### Detroit

Tri-Atria Office Building  
32255 Northwestern Highway, Suite 190  
Farmington Hills, MI 48334  
Tel: 248-538-2250 Fax: 248-538-2260

#### Kokomo

2767 S. Albright Road  
Kokomo, Indiana 46902  
Tel: 765-864-8360 Fax: 765-864-8387

#### Los Angeles

18201 Von Karman, Suite 1090  
Irvine, CA 92612  
Tel: 949-263-1888 Fax: 949-263-1338

#### New York

150 Motor Parkway, Suite 202  
Hauppauge, NY 11788  
Tel: 631-273-5305 Fax: 631-273-5335

#### San Jose

Microchip Technology Inc.  
2107 North First Street, Suite 590  
San Jose, CA 95131  
Tel: 408-436-7950 Fax: 408-436-7955

#### Toronto

6285 Northam Drive, Suite 108  
Mississauga, Ontario L4V 1X5, Canada  
Tel: 905-673-0699 Fax: 905-673-6509

### ASIA/PACIFIC

#### Australia

Microchip Technology Australia Pty Ltd  
Suite 22, 41 Rawson Street  
Epping 2121, NSW  
Australia  
Tel: 61-2-9868-6733 Fax: 61-2-9868-6755

#### China - Beijing

Microchip Technology Consulting (Shanghai)  
Co., Ltd., Beijing Liaison Office  
Unit 915  
Bei Hai Wan Tai Bldg.  
No. 6 Chaoyangmen Beidajie  
Beijing, 100027, No. China  
Tel: 86-10-85282100 Fax: 86-10-85282104

#### China - Chengdu

Microchip Technology Consulting (Shanghai)  
Co., Ltd., Chengdu Liaison Office  
Rm. 2401, 24th Floor,  
Ming Xing Financial Tower  
No. 88 TIDU Street  
Chengdu 610016, China  
Tel: 86-28-6766200 Fax: 86-28-6766599

#### China - Fuzhou

Microchip Technology Consulting (Shanghai)  
Co., Ltd., Fuzhou Liaison Office  
Unit 28F, World Trade Plaza  
No. 71 Wusi Road  
Fuzhou 350001, China  
Tel: 86-591-7503506 Fax: 86-591-7503521

#### China - Shanghai

Microchip Technology Consulting (Shanghai)  
Co., Ltd.  
Room 701, Bldg. B  
Far East International Plaza  
No. 317 Xian Xia Road  
Shanghai, 200051  
Tel: 86-21-6275-5700 Fax: 86-21-6275-5060

#### China - Shenzhen

Microchip Technology Consulting (Shanghai)  
Co., Ltd., Shenzhen Liaison Office  
Rm. 1315, 13/F, Shenzhen Kerry Centre,  
Renminnan Lu  
Shenzhen 518001, China  
Tel: 86-755-2350361 Fax: 86-755-2366086

#### Hong Kong

Microchip Technology Hongkong Ltd.  
Unit 901-6, Tower 2, Metroplaza  
223 Hing Fong Road  
Kwai Fong, N.T., Hong Kong  
Tel: 852-2401-1200 Fax: 852-2401-3431

#### India

Microchip Technology Inc.  
India Liaison Office  
Divyasree Chambers  
1 Floor, Wing A (A3/A4)  
No. 11, O'Shaugnessey Road  
Bangalore, 560 025, India  
Tel: 91-80-2290061 Fax: 91-80-2290062

### Japan

Microchip Technology Japan K.K.  
Benex S-1 6F  
3-18-20, Shinyokohama  
Kohoku-Ku, Yokohama-shi  
Kanagawa, 222-0033, Japan  
Tel: 81-45-471- 6166 Fax: 81-45-471-6122

### Korea

Microchip Technology Korea  
168-1, Youngbo Bldg. 3 Floor  
Samsung-Dong, Kangnam-Ku  
Seoul, Korea 135-882  
Tel: 82-2-554-7200 Fax: 82-2-558-5934

### Singapore

Microchip Technology Singapore Pte Ltd.  
200 Middle Road  
#07-02 Prime Centre  
Singapore, 188980  
Tel: 65-334-8870 Fax: 65-334-8850

### Taiwan

Microchip Technology Taiwan  
11F-3, No. 207  
Tung Hua North Road  
Taipei, 105, Taiwan  
Tel: 886-2-2717-7175 Fax: 886-2-2545-0139

### EUROPE

#### Denmark

Microchip Technology Nordic ApS  
Regus Business Centre  
Lautrup høj 1-3  
Ballerup DK-2750 Denmark  
Tel: 45 4420 9895 Fax: 45 4420 9910

#### France

Microchip Technology SARL  
Parc d'Activite du Moulin de Massy  
43 Rue du Saule Trapu  
Batiment A - ler Etage  
91300 Massy, France  
Tel: 33-1-69-53-63-20 Fax: 33-1-69-30-90-79

#### Germany

Microchip Technology GmbH  
Gustav-Heinemann Ring 125  
D-81739 Munich, Germany  
Tel: 49-89-627-144 0 Fax: 49-89-627-144-44

#### Italy

Microchip Technology SRL  
Centro Direzionale Colleoni  
Palazzo Taurus 1 V. Le Colleoni 1  
20041 Agrate Brianza  
Milan, Italy  
Tel: 39-039-65791-1 Fax: 39-039-6899883

#### United Kingdom

Arizona Microchip Technology Ltd.  
505 Eskdale Road  
Winnersh Triangle  
Wokingham  
Berkshire, England RG41 5TU  
Tel: 44 118 921 5869 Fax: 44-118 921-5820

01/18/02