

## 1.8/2.5/3.3 V LOW JITTER, LOW SKEW CLOCK BUFFER/LEVEL TRANSLATOR

### Features

- Supports single-ended or differential input clock signals
- Generates four differential (LVPECL, LVDS, HCSL) or eight single-ended (CMOS, SSTL, HSTL) outputs
- Provides signal level translation
  - Differential to single-ended
  - Single-ended to differential
  - Differential to differential
  - Single-ended to single-ended
- Wide frequency range
  - LVPECL, LVDS: 5 to 710 MHz
  - HCSL: 5 to 250 MHz
  - SSTL, HSTL: 5 to 350 MHz
  - CMOS: 5 to 200 MHz
- Additive jitter: 150 fs RMS typ
- Output-output skew: 100 ps
- Propagation delay: 2.5 ns typ
- Single core supply with excellent PSRR: 1.8, 2.5, or 3.3 V
- Output driver supply voltage independent of core supply: 1.5, 1.8, 2.5, or 3.3 V
- Loss Of Signal (LOS) indicator allows system clock monitoring
- Output Enable (OEB) pin allows glitchless control of output clocks
- Low power: 10 mA typical core current
- Industrial temperature range: -40 to +85 °C
- Small size: 24-lead, 4 x 4 mm QFN

### Applications

- High Speed Clock Distribution
- Ethernet Switch/Router
- SONET / SDH
- PCI Express 2.0/3.0
- Fibre Channel
- MSAN/DSLAM/PON
- Telecom Line Cards

### Functional Block Diagram

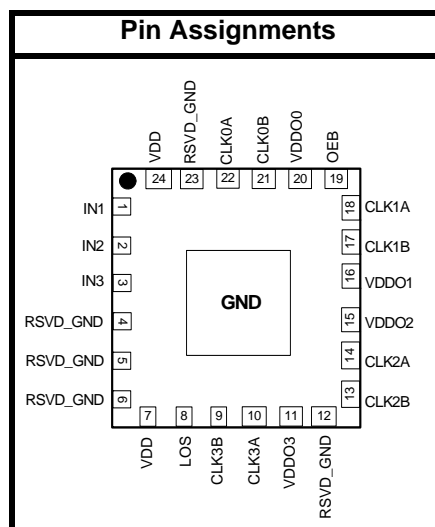
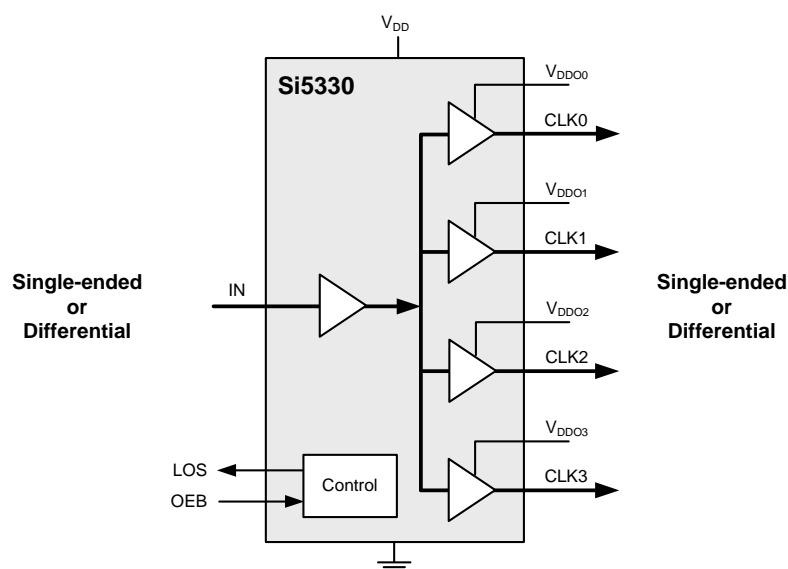

## 1. Functional Block Diagrams Based on Orderable Part Number\*

### 1:4 Differential to Differential Buffer

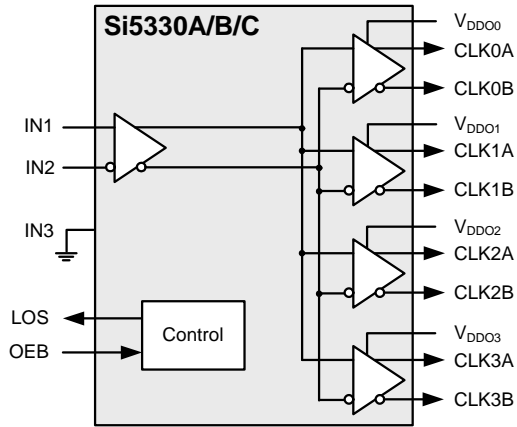

### 1:8 Single-Ended to Single-Ended Buffer

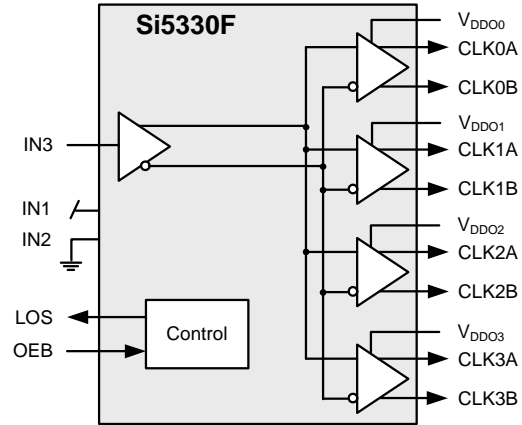

### 1:8 Differential to Single-Ended Buffer

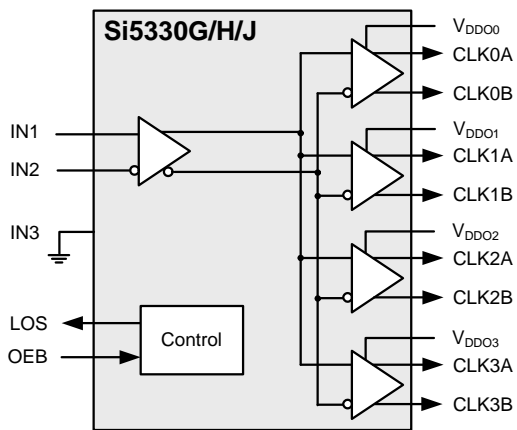

### 1:4 Single-Ended to Differential Buffer

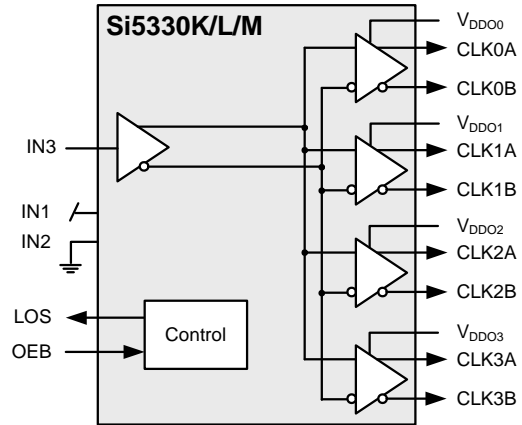

Figure 1. Si5330 Functional Block Diagrams

\*Note: See Table 10 for detailed ordering information.

---

**TABLE OF CONTENTS**

---

| <b><u>Section</u></b>   | <b><u>Page</u></b> |
|---|--------------------|
| <b>1. Functional Block Diagrams Based on Orderable Part Number*</b> ..... | <b>2</b>           |
| <b>2. Electrical Specifications</b> .....                                 | <b>4</b>           |
| <b>3. Functional Description</b> .....                                    | <b>9</b>           |
| 3.1. VDD and VDDO Supplies .....  | 9                  |
| 3.2. Loss Of Signal Indicator (LOS) .....                                 | 9                  |
| 3.3. Output Enable (OEB) .....  | 9                  |
| 3.4. Input Signals .....  | 9                  |
| 3.5. Output Driver Formats .....  | 9                  |
| 3.6. Input and Output Terminations .....                                  | 9                  |
| <b>4. Ordering the Si5330</b> .....                                       | <b>9</b>           |
| <b>5. Pin Descriptions—Si5330</b> .....                                   | <b>10</b>          |
| <b>6. Orderable Part Numbers and Device Functionality</b> .....           | <b>14</b>          |
| <b>7. Package Outline: 24-Lead QFN</b> .....                              | <b>16</b>          |
| <b>8. Recommended PCB Layout</b> .....                                    | <b>17</b>          |
| <b>Document Change List</b> .....   | <b>18</b>          |
| <b>Contact Information</b> .....  | <b>20</b>          |

## 2. Electrical Specifications

**Table 1. Recommended Operating Conditions**

( $V_{DD} = 1.8\text{ V} -5\%$  to  $+10\%$ ,  $2.5\text{ V} \pm 10\%$ , or  $3.3\text{ V} \pm 10\%$ ,  $T_A = -40$  to  $85^\circ\text{C}$ )

| Parameter                    | Symbol     | Test Condition | Min  | Typ | Max  | Unit             |
|------------------------------|------------|----------------|------|-----|------|------------------|
| Ambient Temperature          | $T_A$      |                | -40  | 25  | 85   | $^\circ\text{C}$ |
| Core Supply Voltage          | $V_{DD}$   |                | 2.97 | 3.3 | 3.63 | V                |
|                              |            |                | 2.25 | 2.5 | 2.75 | V                |
|                              |            |                | 1.71 | 1.8 | 1.98 | V                |
| Output Buffer Supply Voltage | $V_{DDOn}$ |                | 1.4  | —   | 3.63 | V                |

**Note:** All minimum and maximum specifications are guaranteed and apply across the recommended operating conditions. Typical values apply at nominal supply voltages and an operating temperature of  $25^\circ\text{C}$  unless otherwise noted.

**Table 2. Absolute Maximum Ratings**

| Parameter                 | Symbol    | Test Condition                   | Value            | Unit             |
|---------------------------|-----------|----------------------------------|------------------|------------------|
| DC Supply Voltage         | $V_{DD}$  |                                  | -0.5 to 3.8      | V                |
| Storage Temperature Range | $T_{STG}$ |                                  | -55 to 150       | $^\circ\text{C}$ |
| ESD Tolerance             |           | HBM<br>(100 pF, 1.5 k $\Omega$ ) | 2.5              | kV               |
| ESD Tolerance             |           | CDM                              | 550              | V                |
| ESD Tolerance             |           | MM                               | 175              | V                |
| Latch-up Tolerance        |           |                                  | JESD78 Compliant |                  |

**Note:** Permanent device damage may occur if the absolute maximum ratings are exceeded. Functional operation should be restricted to the conditions as specified in the operational sections of this data sheet. Exposure to absolute maximum rating conditions for extended periods may affect device reliability.

**Table 3. DC Characteristics**(V<sub>DD</sub> = 1.8 V -5% to +10%, 2.5 V ±10%, or 3.3 V ±10%, T<sub>A</sub> = -40 to 85°C)

| Parameter                    | Symbol            | Test Condition                         | Min | Typ | Max | Unit |
|------------------------------|-------------------|--|-----|-----|-----|------|
| Core Supply Current          | I <sub>DD</sub>   | 50 MHz refclk                          | —   | 10  | —   | mA   |
| Output Buffer Supply Current | I <sub>DDOx</sub> | LVPECL, 710 MHz                        | —   | —   | 30  | mA   |
|                              |                   | LVDS, 710 MHz                          | —   | —   | 8   | mA   |
|                              |                   | HCSL, 250 MHz<br>2 pF load capacitance | —   | —   | 20  | mA   |
|                              |                   | SSTL, 350 MHz                          | —   | —   | 19  | mA   |
|                              |                   | CMOS, 50 MHz<br>15 pF load capacitance | —   | —   | 28  | mA   |
|                              |                   | CMOS, 200 MHz<br>2 pF load capacitance | —   | —   | 28  | mA   |
|                              |                   | HSTL, 350 MHz                          | —   | —   | 19  | mA   |

**Table 4. Thermal Characteristics**

| Parameter                                 | Symbol          | Test Condition | Value | Unit |
|---|-----------------|----------------|-------|------|
| Thermal Resistance<br>Junction to Ambient | θ <sub>JA</sub> | Still Air      | 37    | °C/W |
| Thermal Resistance<br>Junction to Case    | θ <sub>JC</sub> | Still Air      | 25    | °C/W |

**Table 5. Performance Characteristics**(V<sub>DD</sub> = 1.8 V -5% to +10%, 2.5 V ±10%, or 3.3 V ±10%, T<sub>A</sub> = -40 to 85°C)

| Parameter                              | Symbol             | Test Condition                              | Min  | Typ | Max | Unit |
|--|--------------------|---|------|-----|-----|------|
| CLKIN Loss of Signal Assert<br>Time    | t <sub>LOS</sub>   |   | —    | 2.6 | 5   | µs   |
| CLKIN Loss of Signal De-Assert<br>Time | t <sub>LOS_B</sub> |   | 0.01 | 0.2 | 1   | µs   |
| Input-to-Output Propagation<br>Delay   | t <sub>PROP</sub>  |   | —    | 2.5 | —   | ns   |
| Output-Output Skew                     | t <sub>DSKEW</sub> | Outputs at same frequency,<br>signal format | —    | —   | 100 | ps   |

**Table 6. Input and Output Clock Characteristics** $(V_{DD} = 1.8\text{ V } -5\% \text{ to } +10\%, 2.5\text{ V } \pm 10\%, \text{ or } 3.3\text{ V } \pm 10\%, T_A = -40 \text{ to } 85\text{ }^\circ\text{C})$ 

| Parameter  | Symbol     | Test Condition                            | Min   | Typ                      | Max   | Units     |
|--|------------|---|-------|--------------------------|-------|-----------|
| <b>Input Clock (AC Coupled Differential Input Clocks on Pin IN1/2)</b> |            |   |       |                          |       |           |
| Frequency  | $f_{IN}$   |   | 5     | —                        | 710   | MHz       |
| Differential Voltage Swing   | $V_{PP}$   | 710 MHz input                             | 0.4   | —                        | 2.4   | $V_{PP}$  |
| Rise/Fall Time   | $t_R/t_F$  | 20%–80%                                   | —     | —                        | 1.0   | ns        |
| Duty Cycle   | DC         | < 1 ns tr/tf                              | —     | 50                       | —     | %         |
| Input Impedance  | $R_{IN}$   |   | 10    | —                        | —     | $k\Omega$ |
| Input Capacitance  | $C_{IN}$   |   | —     | 3.5                      | —     | pF        |
| <b>Input Clock (DC-Coupled Single-Ended Input Clock on Pin IN3)</b>    |            |   |       |                          |       |           |
| Frequency  | $f_{IN}$   | CMOS                                      | 5     | —                        | 200   | MHz       |
| Input Voltage  | $V_I$      |   | –0.1  | —                        | 3.63  | $V_{pp}$  |
| Input Voltage Swing (CMOS Standard)                                    |            | 200 MHz, $T_r/T_f = 1.3\text{ ns}$        | 0.8   | —                        | 3.73  | V         |
| Rise/Fall Time   | $t_R/t_F$  | 20%–80%                                   | —     | —                        | 4     | ns        |
| Duty Cycle   | DC         | < 2 ns tr/tf                              | —     | 50                       | —     | %         |
| Input Capacitance  | $C_{IN}$   |   | —     | 2                        | —     | pF        |
| <b>Output Clocks (Differential)</b>                                    |            |   |       |                          |       |           |
| Frequency  | $f_{OUT}$  | LVPECL, LVDS                              | 5     | —                        | 710   | MHz       |
|  |            | HCSL                                      | 5     | —                        | 250   | MHz       |
| LVPECL Output Voltage  | $V_{OC}$   | common mode                               | —     | $V_{DDO} - 1.4\text{ V}$ | —     | V         |
|  | $V_{SEPP}$ | peak-to-peak single-ended swing           | 0.55  | 0.8                      | 0.96  | $V_{PP}$  |
| LVDS Output Voltage (2.5/3.3 V)  | $V_{OC}$   | common mode                               | 1.125 | 1.2                      | 1.275 | V         |
|  | $V_{SEPP}$ | peak-to-peak single-ended swing           | 0.25  | 0.35                     | 0.45  | $V_{PP}$  |
| LVDS Output Voltage (1.8 V)  | $V_{OC}$   | common mode                               | 0.8   | 0.875                    | 0.95  | V         |
|  | $V_{SEPP}$ | peak-to-peak single-ended swing           | 0.25  | 0.35                     | 0.45  | $V_{PP}$  |
| HCSL Output Voltage  | $V_{OC}$   | common mode                               | 0.35  | 0.375                    | 0.400 | V         |
|  | $V_{SEPP}$ | peak-to-peak single-ended swing           | 0.575 | 0.725                    | 0.85  | $V_{PP}$  |
| Rise/Fall Time   | $t_R/t_F$  | 20%–80%                                   | —     | —                        | 450   | ps        |
| Duty Cycle*  | DC         | $CK_n < 350\text{ MHz}$                   | 45    | —                        | 55    | %         |
|  |            | $350\text{ MHz} < CLK_n < 710\text{ MHz}$ | 40    | —                        | 60    | %         |
| <b>Output Clocks (Single-Ended)</b>                                    |            |   |       |                          |       |           |
| Frequency  | $f_{OUT}$  | CMOS                                      | 5     | —                        | 200   | MHz       |
|  |            | SSTL, HSTL                                | 5     | —                        | 350   | MHz       |

**Table 6. Input and Output Clock Characteristics (Continued)**(V<sub>DD</sub> = 1.8 V -5% to +10%, 2.5 V ±10%, or 3.3 V ±10%, T<sub>A</sub> = -40 to 85 °C)

| Parameter                   | Symbol                         | Test Condition                             | Min            | Typ  | Max            | Units |
|-----------------------------|--------------------------------|--|----------------|------|----------------|-------|
| CMOS 20%-80% Rise/Fall Time | t <sub>R</sub> /t <sub>F</sub> | 2 pF load                                  | —              | 0.45 | 0.85           | ns    |
| CMOS 20%-80% Rise/Fall Time | t <sub>R</sub> /t <sub>F</sub> | 15 pF load                                 | —              | —    | 1.7            | ns    |
| CMOS Output Resistance      |                                |  | —              | 50   | —              | Ω     |
| SSTL Output Resistance      |                                |  | —              | 50   | —              | Ω     |
| HSTL Output Resistance      |                                |  | —              | 50   | —              | Ω     |
| CMOS Output Voltage         | V <sub>OH</sub>                | 4 mA load                                  | VDDO-0.3       | —    | —              | V     |
|                             | V <sub>OL</sub>                | 4 mA load                                  | —              | —    | 0.3            | V     |
| SSTL Output Voltage         | V <sub>OH</sub>                | SSTL-3 VDDO <sub>x</sub> = 2.97 to 3.63 V  | 0.45xVDDO+0.41 | —    | —              | V     |
|                             | V <sub>OL</sub>                |  | —              | —    | 0.45xVDDO-0.41 | V     |
|                             | V <sub>OH</sub>                | SSTL-2 VDDO <sub>x</sub> = 2.25 to 2.75 V  | 0.5xVDDO+0.41  | —    | —              | V     |
|                             | V <sub>OL</sub>                |  | —              | —    | 0.5xVDDO-0.41  | V     |
|                             | V <sub>OH</sub>                | SSTL-18 VDDO <sub>x</sub> = 1.71 to 1.98 V | 0.5xVDDO+0.34  | —    | —              | V     |
|                             | V <sub>OL</sub>                |  | —              | —    | 0.5xVDDO-0.34  | V     |
| HSTL Output Voltage         | V <sub>OH</sub>                | VDDO = 1.4 to 1.6 V                        | 0.5xVDDO +0.3  | —    | —              | V     |
|                             | V <sub>OL</sub>                |  | —              | —    | 0.5xVDDO-0.3   | V     |
| Duty Cycle*                 | DC                             |  | 45             | —    | 55             | %     |

\*Note: Input clock has a 50% duty cycle.

**Table 7. OEB Input Specifications**

| Parameter          | Symbol   | Test Condition | Min                 | Typ | Max                 | Unit      |
|--------------------|----------|----------------|---------------------|-----|---------------------|-----------|
| Input Voltage Low  | $V_{IL}$ |                | —                   | —   | $0.3 \times V_{DD}$ | V         |
| Input Voltage High | $V_{IH}$ |                | $0.7 \times V_{DD}$ | —   | —                   | V         |
| Input Resistance   | $R_{IN}$ |                | 20                  | —   | —                   | $k\Omega$ |

**Table 8. Jitter Specifications**

( $V_{DD} = 1.8 \text{ V } -5\% \text{ to } +10\%$ ,  $2.5 \text{ V } \pm 10\%$ , or  $3.3 \text{ V } \pm 10\%$ ,  $T_A = -40 \text{ to } 85^\circ\text{C}$ )

| Parameter                                | Symbol         | Test Condition   | Min | Typ   | Max | Unit   |
|--|----------------|--|-----|-------|-----|--------|
| Additive Phase Jitter<br>(12 kHz–20 MHz) | $t_{RPHASE}$   | 0.7 V pk-pk differential input<br>clock at 622.08 MHz with<br>70 ps rise/fall time | —   | 0.150 | —   | ps RMS |
| Additive Phase Jitter<br>(50 kHz–80 MHz) | $t_{RPHASEWB}$ | 0.7 V pk-pk differential input<br>clock at 622.08 MHz with<br>70 ps rise/fall time | —   | 0.225 | —   | ps RMS |



### 3. Functional Description

The Si5330 is a low-jitter, low-skew fanout buffer optimized for high-performance PCB clock distribution applications. The device produces four differential or eight single-ended, low-jitter output clocks from a single input clock. The input can accept either a single-ended or a differential clock allowing the device to function as a clock level translator.

#### 3.1. $V_{DD}$ and $V_{DDO}$ Supplies

The core  $V_{DD}$  and output  $V_{DDO}$  supplies have separate and independent supply pins allowing the core supply to operate at a different voltage than the I/O voltage levels.

The  $V_{DD}$  supply powers the core functions of the device, which operates from 1.8, 2.5, or 3.3 V. Using a lower supply voltage helps minimize the device's power consumption. The  $V_{DDO}$  supply pins are used to set the output signal levels and must be set at a voltage level compatible with the output signal format.

#### 3.2. Loss Of Signal Indicator (LOS)

The input is monitored for a valid clock signal using an LOS circuit that monitors input clock edges and declares an LOS condition when signal edges are not detected over a 5  $\mu$ s observation period. The LOS pin is asserted "low" when valid clock is present. A "high" level on the LOS pin indicates a loss of signal (LOS). The LOS pin must be pulled to  $V_{DD}$  as shown in Figure 2.

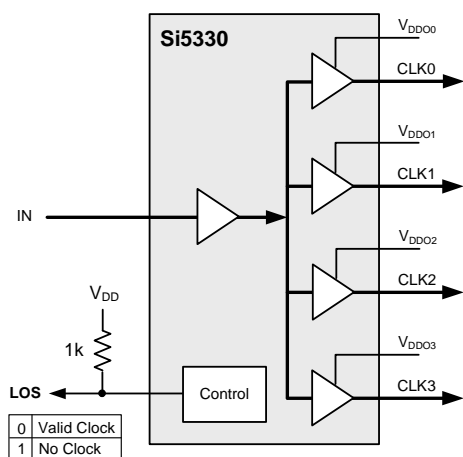

Figure 2. LOS Indicator with External Pull-Up

#### 3.3. Output Enable (OEB)

The output enable (OEB) pin allows disabling or enabling of the outputs clocks (CLK0-CLK3). The output enable is logically controlled to ensure that no glitches or runt pulses are generated at the output as shown in Figure 3.

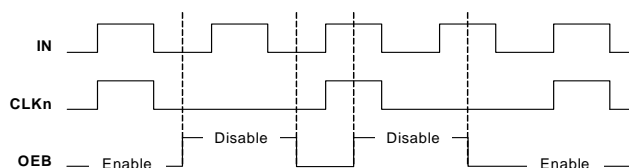

Figure 3. OEB Glitchless Operation

All outputs are enabled when the OEB pin is connected to ground or below the  $V_{IL}$  voltage for this pin. Connecting the OEB pin to  $V_{DD}$  or above the  $V_{IH}$  level will disable the outputs. Both  $V_{IL}$  and  $V_{IH}$  are specified in Table 7. All outputs are forced to a logic "low" when disabled. The OEB pin is 3.3 V tolerant.

#### 3.4. Input Signals

The Si5330 can accept single-ended and differential input clocks. See "AN408: Termination Options for Any-Frequency, Any-Output Clock Generators and Clock Buffers—Si5338, Si5334, Si5330" for details on connecting a wide variety of signals to the Si5330 inputs.

#### 3.5. Output Driver Formats

The Si5330 supports single-ended output formats of CMOS, SSTL, and HSTL and differential formats of LVDS, LVPECL, and HCSL. It is normally required that the LVDS driver be dc-coupled to the 100  $\Omega$  termination at the receiver end. If your application requires an ac-coupled 100  $\Omega$  load, contact the applications team for advice. See AN408 for additional information on the terminations for these driver types.

#### 3.6. Input and Output Terminations

See AN408 for detailed information.

### 4. Ordering the Si5330

The Si5330 can be ordered to meet the requirements of the most commonly-used input and output signal types, such as CMOS, SSTL, HSTL, LVPECL, LVDS, and HSCL. See Figure 1, "Si5330 Functional Block Diagrams," on page 2 and Table 10, "Order Numbers and Device Functionality," on page 14 for specific ordering information.

## 5. Pin Descriptions—Si5330

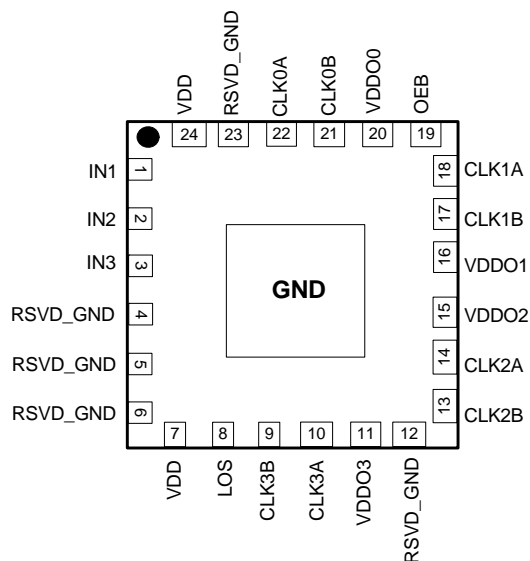

**Note:** Center pad must be tied to GND for normal operation.

**Table 9. Si5330 Pin Descriptions**

| Pin # | Pin Name | I/O | Signal Type | Description  |
|-------|----------|-----|-------------|--|
| 1     | IN1      | I   | Multi       | <b>Si5330A/B/C/G/H/J Differential Input Devices.</b>   |
| 2     | IN2      | I   | Multi       | These pins are used as the differential clock input. IN1 is the positive input; IN2 is the negative input. Refer to “AN408: Termination Options for Any-Frequency, Any-Output Clock Generators and Clock Buffers—Si5338, Si5334, Si5330” for interfacing and termination details.<br><br><b>Si5330F/K/L/M Single-Ended Input Devices.</b><br>These pins are not used. Leave IN1 unconnected and IN2 connected to ground. |
| 3     | IN3      | I   | Multi       | <b>Si5330F/K/L/M Single-Ended Devices.</b><br>This is the single-ended clock input. Refer to AN408 for interfacing and termination details.<br><br><b>Si5330A/B/C/G/H/J Differential Input Devices.</b><br>This pin is not used. Connect to ground.  |
| 4     | RSVD_GND |     |             | <b>Ground.</b><br>Must be connected to system ground.  |
| 5     | RSVD_GND |     |             | <b>Ground.</b><br>Must be connected to system ground.  |
| 6     | RSVD_GND |     |             | <b>Ground.</b><br>Must be connected to system ground.  |

Table 9. Si5330 Pin Descriptions (Continued)

| Pin # | Pin Name | I/O | Signal Type | Description   |
|-------|----------|-----|-------------|---|
| 7     | VDD      | VDD | Supply      | <b>Core Supply Voltage.</b><br>The device operates from a 1.8, 2.5, or 3.3 V supply. A 0.1 $\mu$ F bypass capacitor should be located very close to this pin.   |
| 8     | LOS      | O   | Open Drain  | <b>Loss of Signal Indicator.</b><br>0 = CLKIN present.<br>1 = Loss of signal (LOS).<br>This pin requires an external $\geq 1$ k $\Omega$ pull-up resistor.  |
| 9     | CLK3B    | O   | Multi       | <b>Si5330A/B/C/K/L/M Differential Output Devices.</b><br>This is the negative side of the differential CLK3 output. Refer to AN408 for interfacing and termination details. Leave unconnected when not in use.<br><b>Si5330F/G/H/J Single-Ended Output Devices.</b><br>This is one of the single-ended CLK3 outputs. Both CLK3A and CLK3B single-ended outputs are in phase. Refer to AN408 for interfacing and termination details. Leave unconnected when not is use. |
| 10    | CLK3A    | O   | Multi       | <b>Si5330A/B/C/K/L/M Differential Devices.</b><br>This is the positive side of the differential CLK3 output. Refer to AN408 for interfacing and termination details. Leave unconnected when not in use.<br><b>Si5330F/G/H/J Single-Ended Devices.</b><br>This is one of the single-ended CLK3 outputs. Both CLK3A and CLK3B single-ended outputs are in phase. Refer to AN408 for interfacing and termination details. Leave unconnected when not is use.               |
| 11    | VDDO3    | VDD | Supply      | <b>Output Clock Supply Voltage.</b><br>Supply voltage for CLK3A/B. Use a 0.1 $\mu$ F bypass cap as close as possible to this pin. If CLK3 is not used, this pin must be tied to $V_{DD}$ (pin 7 and/or pin 24).   |
| 12    | RSVD_GND |     |             | <b>Ground.</b><br>Must be connected to system ground.   |
| 13    | CLK2B    | O   | Multi       | <b>Si5330A/B/C/K/L/M Differential Output Devices.</b><br>This is the negative side of the differential CLK2 output. Refer to AN408 for interfacing and termination details. Leave unconnected when not in use.<br><b>Si5330F/G/H/J Single-Ended Output Devices.</b><br>This is one of the single-ended CLK2 outputs. Both CLK2A and CLK2B single-ended outputs are in phase. Refer to AN408 for interfacing and termination details. Leave unconnected when not is use. |

Table 9. Si5330 Pin Descriptions (Continued)

| Pin # | Pin Name | I/O | Signal Type | Description  |
|-------|----------|-----|-------------|--|
| 14    | CLK2A    | O   | Multi       | <p><b>Si5330A/B/C/K/L/M Differential Devices.</b><br/>This is the positive side of the differential CLK2 output. Refer to AN408 for interfacing and termination details. Leave unconnected when not in use.</p> <p><b>Si5330F/G/H/J Single-Ended Devices.</b><br/>This is one of the single-ended CLK2 outputs. Both CLK2A and CLK2B single-ended outputs are in phase. Refer to AN408 for interfacing and termination details. Leave unconnected when not is use.</p>               |
| 15    | VDDO2    | VDD | Supply      | <p><b>Output Clock Supply Voltage.</b><br/>Supply voltage for CLK2A/B. Use a 0.1 <math>\mu</math>F bypass cap as close as possible to this pin. If CLK2 is not used, this pin must be tied to <math>V_{DD}</math> (pin 7 and/or pin 24).</p>   |
| 16    | VDDO1    | VDD | Supply      | <p><b>Output Clock Supply Voltage.</b><br/>Supply voltage for CLK1A,B. Use a 0.1 <math>\mu</math>F bypass cap as close as possible to this pin. If CLK1 is not used, this pin must be tied to <math>V_{DD}</math> (pin 7 and/or pin 24).</p>   |
| 17    | CLK1B    | O   | Multi       | <p><b>Si5330A/B/C/K/L/M Differential Output Devices.</b><br/>This is the negative side of the differential CLK1 output. Refer to AN408 for interfacing and termination details. Leave unconnected when not in use.</p> <p><b>Si5330F/G/H/J Single-Ended Output Devices.</b><br/>This is one of the single-ended CLK1 outputs. Both CLK1A and CLK1B single-ended outputs are in phase. Refer to AN408 for interfacing and termination details. Leave unconnected when not is use.</p> |
| 18    | CLK1A    | O   | Multi       | <p><b>Si5330A/B/C/K/L/M Differential Devices.</b><br/>This is the positive side of the differential CLK1 output. Refer to AN408 for interfacing and termination details. Leave unconnected when not in use.</p> <p><b>Si5330F/G/H/J Single-Ended Devices.</b><br/>This is one of the single-ended CLK1 outputs. Both CLK1A and CLK1B single-ended outputs are in phase. Refer to AN408 for interfacing and termination details. Leave unconnected when not is use.</p>               |
| 19    | OEB      | I   | CMOS        | <p><b>Output Enable.</b><br/>All outputs are enabled when the OEB pin is connected to ground or below the <math>V_{IL}</math> voltage for this pin. Connecting the OEB pin to <math>V_{DD}</math> or above the <math>V_{IH}</math> level will disable the outputs. Both <math>V_{IL}</math> and <math>V_{IH}</math> are specified in Table 7. All outputs are forced to a logic "low" when disabled. This pin is 3.3 V tolerant.</p>   |

Table 9. Si5330 Pin Descriptions (Continued)

| Pin #   | Pin Name | I/O | Signal Type | Description   |
|---------|----------|-----|-------------|---|
| 20      | VDDO0    | VDD | Supply      | <b>Output Clock Supply Voltage.</b><br>Supply voltage for CLK0A,B. Use a 0.1 $\mu$ F bypass cap as close as possible to this pin. If CLK2 is not used, this pin must be tied to $V_{DD}$ (pin 7 and/or pin 24).   |
| 21      | CLK0B    | O   | Multi       | <b>Si5330A/B/C/K/L/M Differential Output Devices.</b><br>This is the negative side of the differential CLK0 output. Refer to AN408 for interfacing and termination details. Leave unconnected when not in use.<br><br><b>Si5330F/G/H/J Single-ended Output Devices.</b><br>This is one of the single-ended CLK0 outputs. Both CLK0A and CLK0B single-ended outputs are in phase. Refer to AN408 for interfacing and termination details. Leave unconnected when not is use. |
| 22      | CLK0A    | O   | Multi       | <b>Si5330A/B/C/K/L/M Differential Devices.</b><br>This is the positive side of the differential CLK0 output. Refer to AN408 for interfacing and termination details. Leave unconnected when not in use.<br><br><b>Si5330F/G/H/J Single-ended Devices.</b><br>This is one of the single-ended CLK0 outputs. Both CLK0A and CLK0B single-ended outputs are in phase. Refer to AN408 for interfacing and termination details. Leave unconnected when not is use.               |
| 23      | RSVD_GND |     |             | <b>Ground.</b><br>Must be connected to system ground.   |
| 24      | VDD      | VDD | Supply      | <b>Core Supply Voltage.</b><br>The device operates from a 1.8, 2.5, or 3.3 V supply. A 0.1 $\mu$ F bypass capacitor should be located very close to this pin.   |
| GND PAD | GND      | GND | Supply      | <b>Ground Pad.</b><br>This is main ground connection for this device. It is located at the bottom center of the package. Use as many vias as possible to connect this pad to the main ground plane.   |

## 6. Orderable Part Numbers and Device Functionality

Table 10. Order Numbers and Device Functionality

| Part Number   | Input Signal Format | Output Signal Format | Number of Outputs | Frequency Range |
|---|---------------------|----------------------|-------------------|-----------------|
| <b>LVPECL Buffers</b>   |                     |                      |                   |                 |
| Si5330A-A00200-GM   | Differential        | 3.3 V LVPECL         | 4                 | 5 to 710 MHz    |
| Si5330A-A00202-GM   | Differential        | 2.5 V LVPECL         | 4                 | 5 to 710 MHz    |
| <b>LVDS Buffers</b>   |                     |                      |                   |                 |
| Si5330B-A00204-GM   | Differential        | 3.3 V LVDS           | 4                 | 5 to 710 MHz    |
| Si5330B-A00205-GM   | Differential        | 2.5 V LVDS           | 4                 | 5 to 710 MHz    |
| Si5330B-A00206-GM   | Differential        | 1.8 V LVDS           | 4                 | 5 to 710 MHz    |
| <b>HCSL Buffers</b>   |                     |                      |                   |                 |
| Si5330C-A00207-GM   | Differential        | 3.3 V HCSL           | 4                 | 5 to 250 MHz    |
| Si5330C-A00208-GM   | Differential        | 2.5 V HCSL           | 4                 | 5 to 250 MHz    |
| Si5330C-A00209-GM   | Differential        | 1.8 V HCSL           | 4                 | 5 to 250 MHz    |
| <b>CMOS Buffers</b>   |                     |                      |                   |                 |
| Si5330F-A00214-GM   | Single-Ended        | 3.3 V CMOS           | 8                 | 5 to 200 MHz    |
| Si5330F-A00215-GM   | Single-Ended        | 2.5 V CMOS           | 8                 | 5 to 200 MHz    |
| Si5330F-A00216-GM   | Single-Ended        | 1.8 V CMOS           | 8                 | 5 to 200 MHz    |
| <b>CMOS Buffers (Differential Input)</b>  |                     |                      |                   |                 |
| Si5330G-A00217-GM   | Differential        | 3.3 V CMOS           | 8                 | 5 to 200 MHz    |
| Si5330G-A00218-GM   | Differential        | 2.5 V CMOS           | 8                 | 5 to 200 MHz    |
| Si5330G-A00219-GM   | Differential        | 1.8 V CMOS           | 8                 | 5 to 200 MHz    |
| <b>SSTL Buffers (Differential Input)</b>  |                     |                      |                   |                 |
| Si5330H-A00220-GM   | Differential        | 3.3 V SSTL           | 8                 | 5 to 350 MHz    |
| Si5330H-A00221-GM   | Differential        | 2.5 V SSTL           | 8                 | 5 to 350 MHz    |
| Si5330H-A00222-GM   | Differential        | 1.8 V SSTL           | 8                 | 5 to 350 MHz    |
| <b>HSTL Buffers (Differential Input)</b>  |                     |                      |                   |                 |
| Si5330J-A00223-GM   | Differential        | 1.5 V HSTL           | 8                 | 5 to 350 MHz    |
| <b>LVPECL Buffers (Single-Ended Input)</b>  |                     |                      |                   |                 |
| Si5330K-A00224-GM   | Single-Ended        | 3.3 V LVPECL         | 4                 | 5 to 350 MHz    |
| Si5330K-A00226-GM   | Single-Ended        | 2.5 V LVPECL         | 4                 | 5 to 350 MHz    |
| <b>Note:</b> Custom configurations with mixed output types are also available. Please contact the factory for ordering details. |                     |                      |                   |                 |

Table 10. Order Numbers and Device Functionality (Continued)

| Part Number   | Input Signal Format | Output Signal Format | Number of Outputs | Frequency Range |
|---|---------------------|----------------------|-------------------|-----------------|
| <b>LVDS Buffers (Single-Ended Input)</b>  |                     |                      |                   |                 |
| Si5330L-A00228-GM   | Single-Ended        | 3.3 V LVDS           | 4                 | 5 to 350 MHz    |
| Si5330L-A00229-GM   | Single-Ended        | 2.5 V LVDS           | 4                 | 5 to 350 MHz    |
| Si5330L-A00230-GM   | Single-Ended        | 1.8 V LVDS           | 4                 | 5 to 350 MHz    |
| <b>HCSL Buffers (Single-Ended Input)</b>  |                     |                      |                   |                 |
| Si5330M-A00231-GM   | Single-Ended        | 3.3 V HCSL           | 4                 | 5 to 250 MHz    |
| Si5330M-A00232-GM   | Single-Ended        | 2.5 V HCSL           | 4                 | 5 to 250 MHz    |
| Si5330M-A00233-GM   | Single-Ended        | 1.8 V HCSL           | 4                 | 5 to 250 MHz    |
| <b>Note:</b> Custom configurations with mixed output types are also available. Please contact the factory for ordering details. |                     |                      |                   |                 |

## 7. Package Outline: 24-Lead QFN

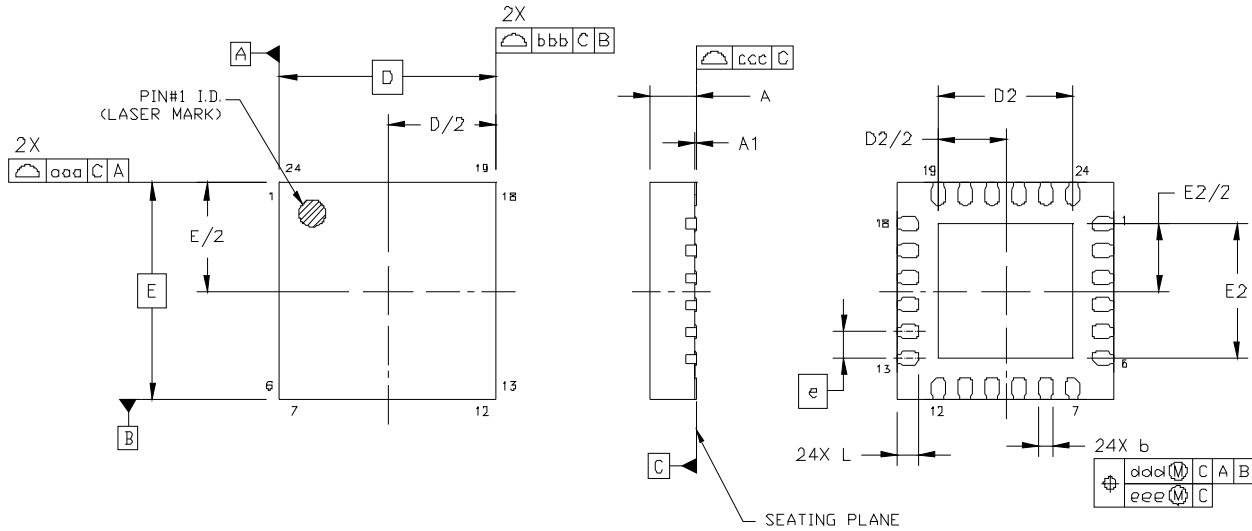

**Figure 4. 24-Lead Quad Flat No-lead (QFN)**

**Table 11. Package Dimensions**

| Dimension | Min       | Nom  | Max  |
|-----------|-----------|------|------|
| A         | 0.80      | 0.85 | 0.90 |
| A1        | 0.00      | 0.02 | 0.05 |
| b         | 0.18      | 0.25 | 0.30 |
| D         | 4.00 BSC. |      |      |
| D2        | 2.35      | 2.50 | 2.65 |
| e         | 0.50 BSC. |      |      |
| E         | 4.00 BSC. |      |      |
| E2        | 2.35      | 2.50 | 2.65 |
| L         | 0.30      | 0.40 | 0.50 |
| aaa       | 0.10      |      |      |
| bbb       | 0.10      |      |      |
| ccc       | 0.08      |      |      |
| ddd       | 0.10      |      |      |
| eee       | 0.05      |      |      |

**Notes:**

1. All dimensions shown are in millimeters (mm) unless otherwise noted.
2. Dimensioning and Tolerancing per ANSI Y14.5M-1994.
3. This drawing conforms to the JEDEC Outline MO-220, variation VGGD-8.
4. Recommended card reflow profile is per the JEDEC/IPC J-STD-020 specification for Small Body Components.



## 8. Recommended PCB Layout

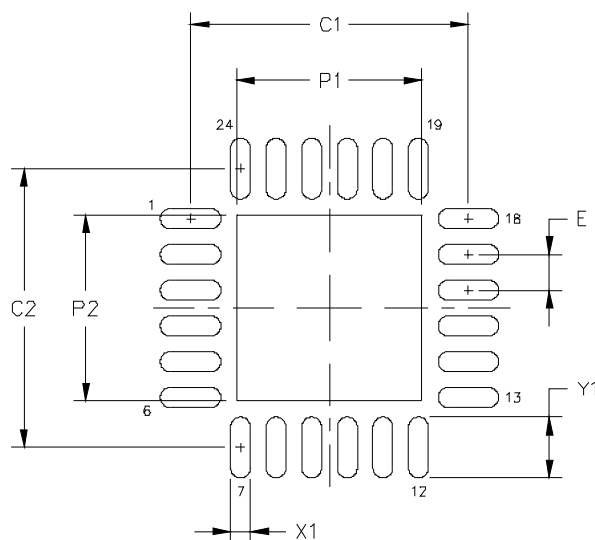

**Table 12. PCB Land Pattern**

| Dimension | Min  | Nom  | Max  |
|-----------|------|------|------|
| P1        | 2.50 | 2.55 | 2.60 |
| P2        | 2.50 | 2.55 | 2.60 |
| X1        | 0.20 | 0.25 | 0.30 |
| Y1        | 0.75 | 0.80 | 0.85 |
| C1        |      | 3.90 |      |
| C2        |      | 3.90 |      |
| E         |      | 0.50 |      |

### Notes:

#### General

- All dimensions shown are in millimeters (mm) unless otherwise noted.
- Dimensioning and Tolerancing per ANSI Y14.5M-1994 specification.
- This Land Pattern Design is based on the IPC-7351 guidelines.
- Connect the center ground pad to a ground plane with no less than five vias to a ground plane that is no more than 20 mils below it. Via drill size should be no smaller than 10 mils. A longer distance to the ground plane is allowed if more vias are used to keep the inductance from increasing.

#### Solder Mask Design

- All metal pads are to be non-solder mask defined (NSMD). Clearance between the solder mask and the metal pad is to be 60  $\mu\text{m}$  minimum, all the way around the pad.

#### Stencil Design

- A stainless steel, laser-cut and electro-polished stencil with trapezoidal walls should be used to assure good solder paste release.
- The stencil thickness should be 0.125 mm (5 mils).
- The ratio of stencil aperture to land pad size should be 1:1 for all perimeter pins.
- A 2x2 array of 1.0 mm square openings on 1.25 mm pitch should be used for the center ground pad.

#### Card Assembly

- A No-Clean, Type-3 solder paste is recommended.
- The recommended card reflow profile is per the JEDEC/IPC J-STD-020C specification for Small Body Components.

## DOCUMENT CHANGE LIST

### Revision 0.1 to Revision 0.2

- Clarified documentation to reflect that Pin 19 is OEB (OE Enable Low).
- Updated Table 4, “Jitter Specifications” on page 7.

### Revision 0.2 to Revision 0.3

- Major editorial updates to improve clarity.
- Updated “Additive Jitter” Specification Table.
- Updated “Core Supply Current” Specification in Table 3.
- Removed the Low-Power LVPECL output options from the ordering table in section 6.
- Removed D/E ordering options.

### Revision 0.3 to Revision 0.35

- Typo of 150 ps on front page changed to 150 fs.
- Updated PCB layout notes.
- Added no ac coupling for LVDS outputs.
- Changed input rise/fall time spec to 2 ns.

**NOTES:**

## CONTACT INFORMATION

### Silicon Laboratories Inc.

400 West Cesar Chavez  
Austin, TX 78701  
Tel: 1+(512) 416-8500  
Fax: 1+(512) 416-9669  
Toll Free: 1+(877) 444-3032

Please visit the Silicon Labs Technical Support web page:  
<https://www.silabs.com/support/pages/contacttechnicalsupport.aspx>  
and register to submit a technical support request.

The information in this document is believed to be accurate in all respects at the time of publication but is subject to change without notice. Silicon Laboratories assumes no responsibility for errors and omissions, and disclaims responsibility for any consequences resulting from the use of information included herein. Additionally, Silicon Laboratories assumes no responsibility for the functioning of undescribed features or parameters. Silicon Laboratories reserves the right to make changes without further notice. Silicon Laboratories makes no warranty, representation or guarantee regarding the suitability of its products for any particular purpose, nor does Silicon Laboratories assume any liability arising out of the application or use of any product or circuit, and specifically disclaims any and all liability, including without limitation consequential or incidental damages. Silicon Laboratories products are not designed, intended, or authorized for use in applications intended to support or sustain life, or for any other application in which the failure of the Silicon Laboratories product could create a situation where personal injury or death may occur. Should Buyer purchase or use Silicon Laboratories products for any such unintended or unauthorized application, Buyer shall indemnify and hold Silicon Laboratories harmless against all claims and damages.

Silicon Laboratories and Silicon Labs are trademarks of Silicon Laboratories Inc.  
Other products or brandnames mentioned herein are trademarks or registered trademarks of their respective holders.