

Customer Information Sheet

DRAWING No.: M83-LFCIFIN60-0000-000

SHEET 2 OF 2

IF IN DOUBT - ASK

Ⓒ

NOT TO SCALE

THIRD ANGLE PROJECTION

ALL DIMENSIONS IN mm

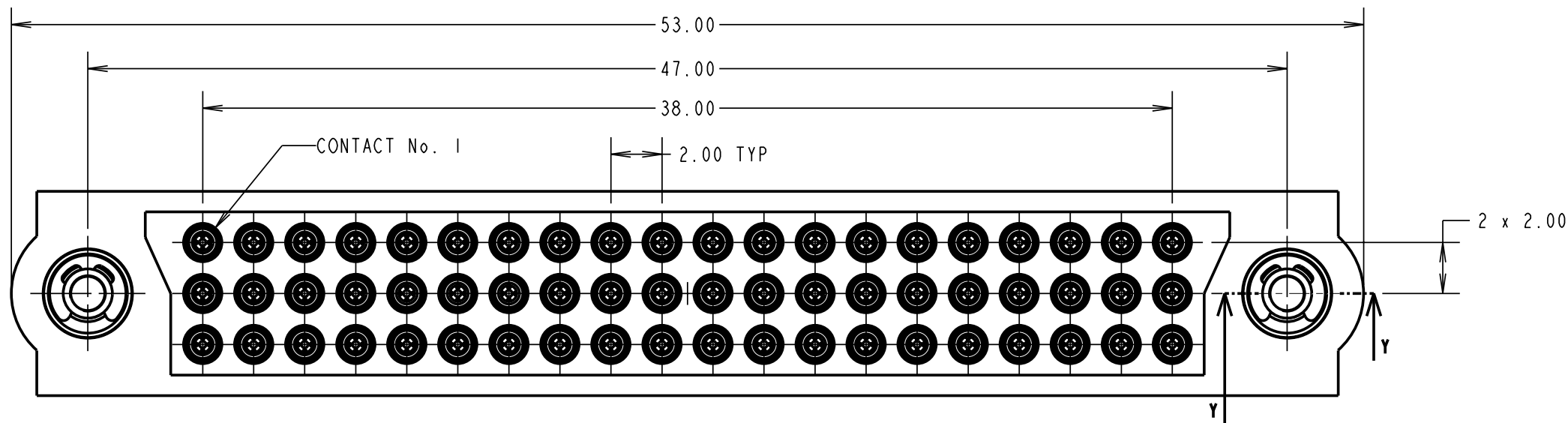

SPECIFICATIONS:
MATERIAL:
 MOULDING = GLASS-FILLED PPS, UL94V-0, BLACK
 JACKSCREW = STAINLESS STEEL
 CONTACT CLIP = BERYLLIUM COPPER
 CONTACT SHELL = BRASS
FINISH:
 CONTACT CLIP = 0.3µ GOLD
 CONTACT SHELL = 0.25-0.3µ GOLD
ELECTRICAL:
 CURRENT RATING AT 25°C = 3.0A MAX
 CURRENT RATING AT 85°C = 2.2A MAX
 WORKING VOLTAGE = 120V AC/DC
 VOLTAGE PROOF = 360V AC/DC
 CONTACT RESISTANCE = 25 mΩ MAX
 INSULATION RESISTANCE = 100 MΩ MIN
MECHANICAL:
 DURABILITY = 500 OPERATIONS
 INSERTION FORCE = 1.0N MAX
 WITHDRAWAL FORCE = 0.2N MIN
ENVIRONMENTAL:
 TEMPERATURE RANGE = -55°C TO +125°C
PACKING:
 BAG
 FOR COMPLETE SPECIFICATION, SEE COMPONENT SPECIFICATION C005XX (LATEST ISSUE)

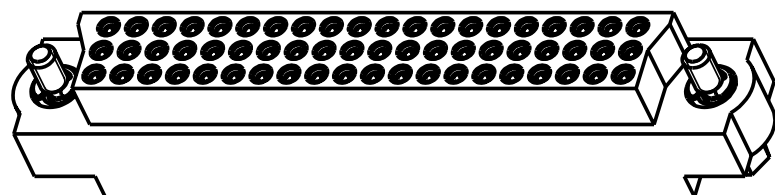
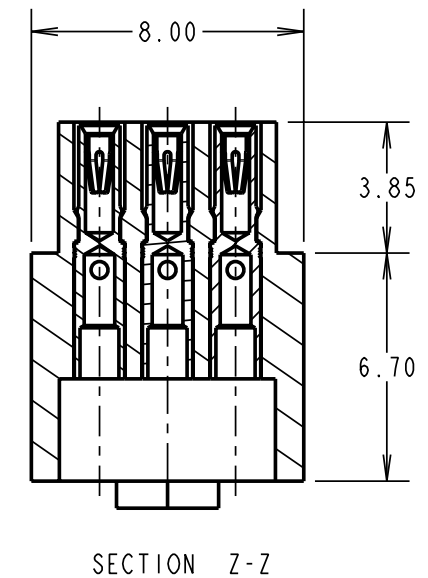
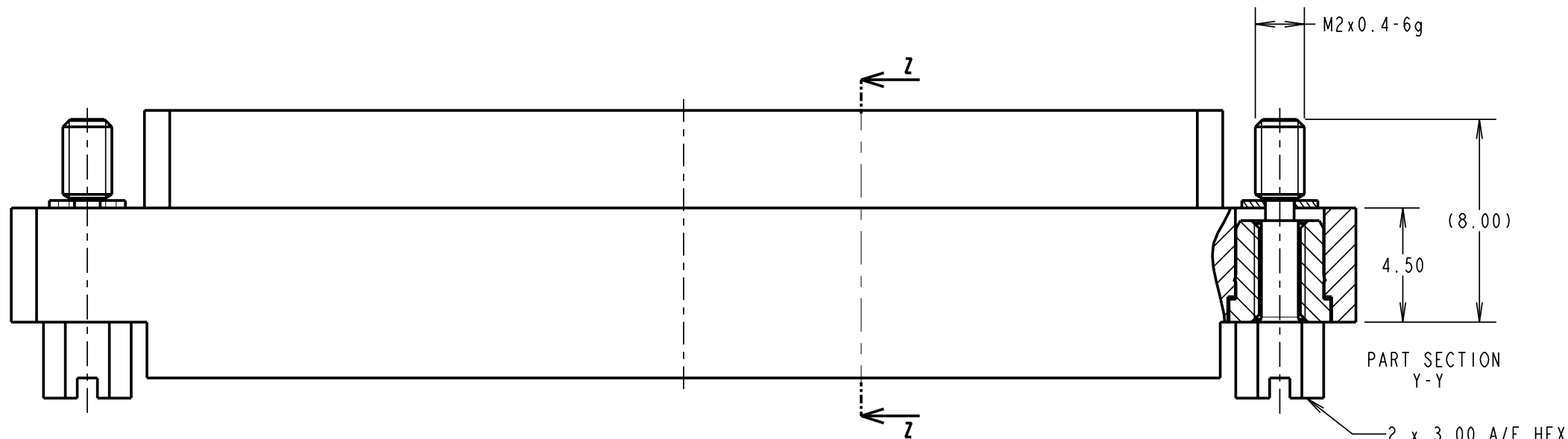

NOTES:

- CONNECTORS ARE SUPPLIED WITH CONTACTS LOOSE.
- FOR EXTRA CONTACTS, USE PART NUMBER M83-0130005.
- RECOMMENDED WIRE TYPE = BS 3G 210 TYPE A, PTFE INSULATED 24-28 AWG. MAX INSULATION DIAMETER = Ø1.10mm, STRIP WIRE BY 2.00mm.
- RECOMMENDED HAND CRIMP TOOL = M22520/2-01 WITH POSITIONER T5747, SEE INSTRUCTION SHEET IS-01 FOR DETAILS.
- CONTACT INSERTION AND EXTRACTION TOOL = Z80-280, SEE INSTRUCTION SHEET IS-25 FOR DETAILS.

RA	A	11.03.08	----
NAME	ISS.	DATE	C/NOTE
APPROVED:		R.ADDE	
CHECKED:		M.G.PLESTED	
DRAWN:		R.ADDE	
CUSTOMER REF.:			
ASSEMBLY DRG:			

HARWIN			THIS DRAWING AND ANY INFORMATION OR DESCRIPTIVE MATTER SET OUT HEREON ARE CONFIDENTIAL AND COPYRIGHT PROPERTY OF THE HARWIN GROUP AND MUST NOT BE DISCLOSED, LOANED, COPIED OR USED FOR MANUFACTURING, TENDERING OR FOR ANY OTHER PURPOSE WITHOUT THEIR WRITTEN PERMISSION.	TOLERANCES X. = ±1mm X.X = ±0.25mm X.XX = ±0.10mm X.XXX = ±0.01mm ANGLES = ±5° UNLESS STATED	MATERIAL: SEE ABOVE FINISH: SEE ABOVE S/AREA: mm ²	TITLE: JACKSCREW DATAMATE 3-ROW CRIMP FEMALE ASSY (60-WAY) DRAWING NUMBER: M83-LFCIFIN60-0000-000	SHT 2 OF 2
HARWIN USA TEL: 603 893 5376 FAX: 603 893 5396 mis@harwin.com	HARWIN Europe (UK) TEL: 023 9231 4545 FAX: 023 9231 4590 mis@harwin.co.uk	HARWIN Asia TEL: +65 6 779 4909 FAX: +65 6 779 3868 mis@harwin.com.sg		S/AREA: mm ²	DRAWING NUMBER: M83-LFCIFIN60-0000-000		