

PLEASE CHECK WWW.MOLEX.COM FOR LATEST PART INFORMATION

Part Number: [0022233044](#)
Status: **Active**
Description: 2.54mm (.100") Pitch KK® Solid Header, Vertical, with Staggered Tail, 4 Circuits

Documents:

[3D Model](#) [RoHS Certificate of Compliance \(PDF\)](#)
[Drawing \(PDF\)](#)

Agency Certification

CSA LR19980
 UL E29179

General

Product Family PCB Headers
 Series [42009](#)
 Application Wire-to-Board
 Product Name KK®

Physical

Breakaway No
 Circuits (Loaded) 4
 Circuits (maximum) 4
 Color - Resin Natural
 Durability (mating cycles max) 25
 Flammability 94V-0
 Glow-Wire Compliant No
 Lock to Mating Part Yes
 Material - Plating Mating Tin
 Material - Plating Termination Tin
 Material - Resin Polyester
 Number of Rows 1
 Orientation Vertical
 PC Tail Length (in) 0.130 In
 PC Tail Length (mm) 3.30 mm
 PCB Locator No
 PCB Retention Yes
 PCB Thickness Recommended (in) 0.062 In
 PCB Thickness Recommended (mm) 1.60 mm
 Packaging Type Bag
 Pitch - Mating Interface (in) 0.100 In
 Pitch - Mating Interface (mm) 2.54 mm
 Plating min: Mating (µin) 200
 Plating min: Mating (µm) 5
 Plating min: Termination (µin) 200
 Plating min: Termination (µm) 5
 Polarized to Mating Part Yes
 Polarized to PCB No
 Shrouded Partial
 Stackable No
 Temperature Range - Operating 0°C to +75°C
 Termination Interface: Style Through Hole

Electrical

Current - Maximum per Contact 4A
 Voltage - Maximum 250V

Solder Process Data

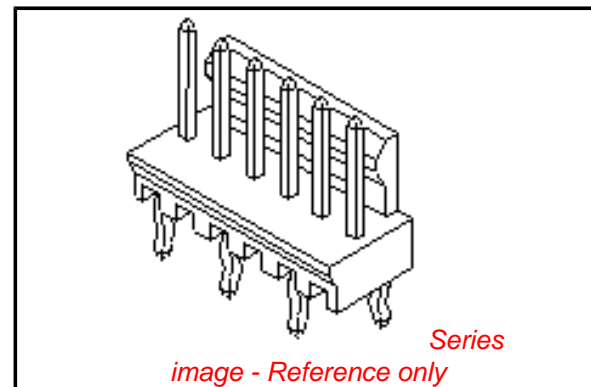

EU RoHS

**ELV and RoHS
 Compliant**
**REACH SVHC
 Contains SVHC: No**
**Halogen-Free
 Status
 Not Reviewed**

China RoHS



**Need more information on product
 environmental compliance?**

Email productcompliance@molex.com
 For a multiple part number RoHS Certificate of
 Compliance, [click here](#)

Please visit the [Contact Us](#) section for any
 non-product compliance questions.

Search Parts in this Series

[42009Series](#)

Mates With

[2695](#) , [6471](#) , [7880](#) , [4455](#) , [7720](#) , [40555](#)

Duration at Max. Process Temperature (seconds)	5
Lead-free Process Capability	Wave Capable (TH only)
Max. Cycles at Max. Process Temperature	1
Process Temperature max. C	235

Material Info

Old Part Number	A-42009-04
-----------------	------------

Reference - Drawing Numbers

Sales Drawing	SDA-42009-*
---------------	-------------

This document was generated on 03/19/2010

PLEASE CHECK WWW.MOLEX.COM FOR LATEST PART INFORMATION

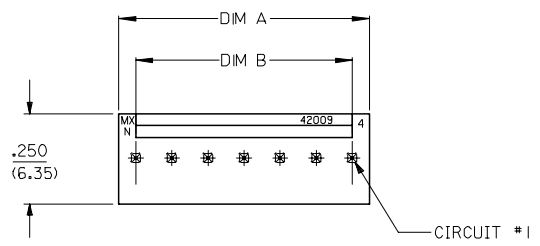

- NOTES
1. MATERIAL: INSULATOR - POLYESTER, GLASS FILLED
PIN - BRASS
 2. FINISH: TIN: .000200/(0.00508) MIN.,
OVERALL COPPER UNDERPLATE: .000100/(0.00254) MIN.
 3. PRODUCT SPECIFICATION: PS-10-07
 4. BULK PACK PER PK-43009-001
 5. THIS PART CONFORMS TO CLASS B REQUIREMENTS OF
COSMETIC SPECIFICATION PS-45499-002.

ENG. NO. DESIGNATION:

A-42009- N * - **
 CKT. SIZE ——— VOID PIN DESIGNATION
 A = #1 PIN
 B = #2 PIN
 C = #3 PIN
 ECT.

MOLDED COLOR:
 BLANK = NATURAL
 A = BLUE
 E = GREEN
 R = RED
 H = BLACK

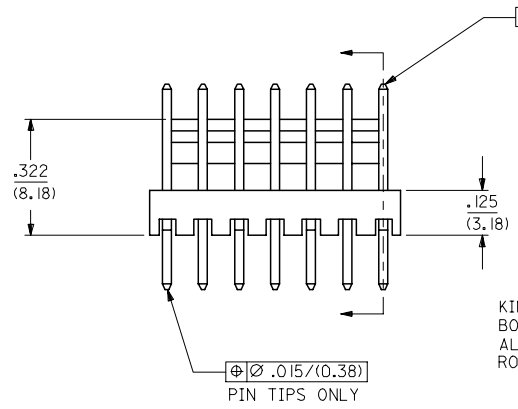

KINKED PINS FOR P.C. BOARD RETENTION- ALL PINS KINKED, TWO ROWS OPPOSING EACH OTHER

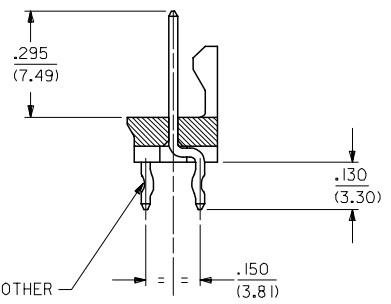

10	.995/(25.27)	.900/(22.86)
9	.895/(22.73)	.800/(20.32)
8	.795/(20.19)	.700/(17.78)
7	.695/(17.65)	.600/(15.24)
6	.595/(15.11)	.500/(12.70)
5	.495/(12.57)	.400/(10.16)
4	.395/(10.03)	.300/(7.62)
3	.295/(7.49)	.200/(5.08)
2	.195/(4.95)	.100/(2.54)
CKT SIZE	DIM A	DIM B

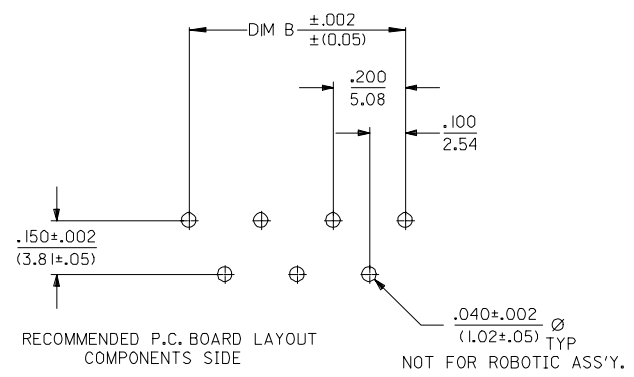
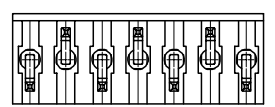

3	I1
2	H1
1	J1
SHT. REV.	

ADD TOL. BLOCK EC NO: UCP2007-1476 DRAWN/PR/DER 2006/12/19 CHKD:ADERR 2006/12/19 APPR:FSM TH 2006/12/20 J1 REV	QUALITY SYMBOLS ▽=0 ▽=0	GENERAL TOLERANCES (UNLESS SPECIFIED)		DIMENSION STYLE IN/MM		SCALE 1:1	DESIGN UNITS INCH	THIRD ANGLE PROJECTION
		4 PLACES ± --- ± --- 3 PLACES ± --- ± .010 2 PLACES ± 0.25 ± .014 1 PLACE ± 0.36 ± --- ANGULAR ±1/2°	DRAWN BY EDGLEY	DATE 1986/11/29	TITLE WAFER, FRICTION LOCK ASSEMBLY			
		DRAFT WHERE APPLICABLE MUST REMAIN WITHIN DIMENSIONS	CHECKED BY EDGLEY	DATE 1986/11/29	MOLEX INCORPORATED			
		SEE CHART	APPROVED BY EDGLEY	DATE 1986/11/29	MATERIAL NO. SDA-42009-*	DOCUMENT NO.	SHEET NO. 1 OF 3	

13		12		11		10		9		8		7		6		4		3		2		1																									
A-42009-N												A-42009-NA												A-42009-NE												A-42009-NH											
PART NO.	ENG. NO.	VOID CKT.	PART NO.	ENG. NO.	VOID CKT.	PART NO.	ENG. NO.	VOID CKT.	PART NO.	ENG. NO.	VOID CKT.	PART NO.	ENG. NO.	VOID CKT.	PART NO.	ENG. NO.	VOID CKT.	PART NO.	ENG. NO.	VOID CKT.	PART NO.	ENG. NO.	VOID CKT.																								
22-23-3024	A-42009-2	NONE	22-23-5026	A-42009-2A	NONE	22-23-5027	A-42009-2E	NONE	22-23-5028	A-42009-2H	NONE	22-23-5029	A-42009-2I	NONE	22-23-5030	A-42009-2J	NONE	22-23-5031	A-42009-2K	NONE	22-23-5032	A-42009-2L	NONE																								
22-23-3034	A-42009-3	NONE	22-23-5036	A-42009-3A	NONE	22-23-5037	A-42009-3E	NONE	22-23-5038	A-42009-3H	NONE	22-23-5039	A-42009-3I	NONE	22-23-5040	A-42009-3J	NONE	22-23-5041	A-42009-3K	NONE	22-23-5042	A-42009-3L	NONE																								
22-23-3044	A-42009-4	NONE	22-23-5046	A-42009-4A	NONE	22-23-5047	A-42009-4E	NONE	22-23-5048	A-42009-4H	NONE	22-23-5049	A-42009-4I	NONE	22-23-5050	A-42009-4J	NONE	22-23-5051	A-42009-4K	NONE	22-23-5052	A-42009-4L	NONE																								
22-23-3054	A-42009-5	NONE	22-23-5056	A-42009-5A	NONE	22-23-5057	A-42009-5E	NONE	22-23-5058	A-42009-5H	NONE	22-23-5059	A-42009-5I	NONE	22-23-5060	A-42009-5J	NONE	22-23-5061	A-42009-5K	NONE	22-23-5062	A-42009-5L	NONE																								
22-23-3064	A-42009-6	NONE	22-23-5066	A-42009-6A	NONE	22-23-5067	A-42009-6E	NONE	22-23-5068	A-42009-6H	NONE	22-23-5069	A-42009-6I	NONE	22-23-5070	A-42009-6J	NONE	22-23-5071	A-42009-6K	NONE	22-23-5072	A-42009-6L	NONE																								
22-23-3074	A-42009-7	NONE	22-23-5076	A-42009-7A	NONE	22-23-5077	A-42009-7E	NONE	22-23-5078	A-42009-7H	NONE	22-23-5079	A-42009-7I	NONE	22-23-5080	A-42009-7J	NONE	22-23-5081	A-42009-7K	NONE	22-23-5082	A-42009-7L	NONE																								
22-23-3084	A-42009-8	NONE	22-23-5086	A-42009-8A	NONE	22-23-5087	A-42009-8E	NONE	22-23-5088	A-42009-8H	NONE	22-23-5089	A-42009-8I	NONE	22-23-5090	A-42009-8J	NONE	22-23-5091	A-42009-8K	NONE	22-23-5092	A-42009-8L	NONE																								
22-23-3094	A-42009-9	NONE	22-23-5096	A-42009-9A	NONE	22-23-5097	A-42009-9E	NONE	22-23-5098	A-42009-9H	NONE	22-23-5099	A-42009-9I	NONE	22-23-5100	A-42009-9J	NONE	22-23-5101	A-42009-9K	NONE	22-23-5102	A-42009-9L	NONE																								
22-23-3104	A-42009-10	NONE	22-23-5106	A-42009-10A	NONE	22-23-5107	A-42009-10E	NONE	22-23-5108	A-42009-10H	NONE	22-23-5109	A-42009-10I	NONE	22-23-5110	A-42009-10J	NONE	22-23-5111	A-42009-10K	NONE	22-23-5112	A-42009-10L	NONE																								
22-46-4041	A-42009-4-B	2																																													
22-46-4042	A-42009-4-C	3																																													
22-46-4052	A-42009-5-B	2																																													
22-46-4053	A-42009-5-C	3																																													
22-46-4050	A-42009-5-D	4																																													
22-46-4051	A-42009-5-E	5																																													
22-46-4064	A-42009-6-B	2																																													
	A-42009-6-BC	2,3																																													
22-46-4068	A-42009-6-D	4																																													
22-46-4065	A-42009-6-E	5																																													
22-46-4069	A-42009-6-F	6																																													
22-46-4072	A-42009-7-E	5																																													
22-46-4080	A-42009-8-D	4																																													
22-46-4081	A-42009-8-E	5																																													
22-46-4081	A-42009-8-E	5																																													
22-46-4031	A-42009-3-C	3																																													
22-46-4063	A-42009-6-DE	4,5																																													
22-46-4062	A-42009-6-CF	3,6																																													
22-46-4061	A-42009-6-BD	2,4																																													
22-46-4030	A-42009-3-B	2																																													
22-46-4066	A-42009-6-C	3																																													
22-46-4071	A-42009-7-D	4																																													
22-46-4067	A-42009-6-CE	3,5																																													
22-46-4074	A-42009-7-C	3																																													
22-46-4075	A-42009-7-F	6																																													
22-46-4073	A-42009-7-B	2																																													
22-46-4082	A-42009-8-H	8																																													
22-46-4083	A-42009-8-F	6																																													
22-46-4101	A-42009-10-1	9																																													
22-46-4100	A-42009-10-B	2																																													
22-46-4043	A-42009-4-D	2,5																																													
22-46-4060	A-42009-6-BE	2,4																																													

MOLDDED COLOR: _____
 BLANK = NATURAL
 A = BLUE
 E = GREEN
 R = RED
 H = BLACK

VOID PIN DESIGNATION
 A# #1 PIN
 B# #2 PIN
 C# #3 PIN
 ECT.

DIMENSIONS SHOWN UNLESS OTHERWISE SPECIFIED
 UNLESS OTHERWISE SPECIFIED
 3 HOLE ± .010
 2 HOLE ± .010
 1 HOLE ± .010

PART NO. 542009X2
 TITLE WAFER FRICTION LOCK ASSEMBLY
 DATE 9/11/87
 DESIGNED BY SD A-42009-4
 CHECKED BY KK
 DRAWN BY KK

REVISE ONLY ON CAD SYSTEM
 SCALE 1:1