

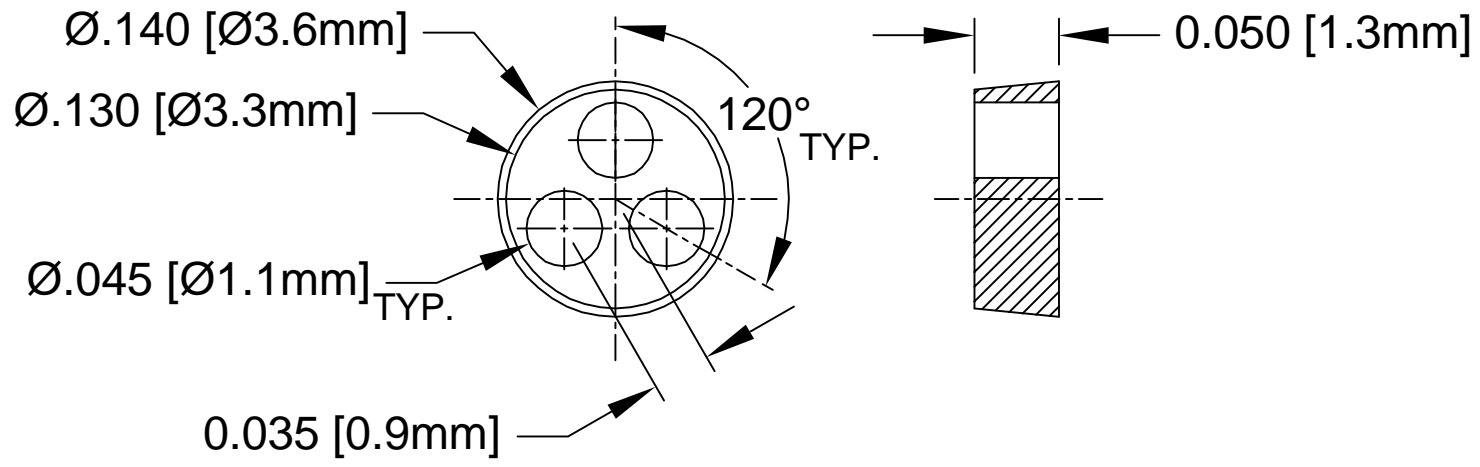
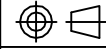

REV.	DESCRIPTION	DATE	APPROVED
A	Engineering Update w/o Changes	02/16/04	M. C.



- 2. MATERIAL: NYLON 6/6, 94V-2, WHITE. BIVAR MATERIAL CODE 04-WE. BASF ULTRAMID NYLON 6/6 A3K WHITE.
- 1. GENERAL SPECIFICATIONS: BIVAR MOLDED COMPONENT SPECIFICATION BV00-E101.

STANDARD TOLERANCE ( UNLESS OTHERWISE SPECIFIED )		 4 THOMAS, IRVINE, CA. 92618 TEL: (949) 951-8808 FAX: (949) 951-3974			
DECIMALS	ANGULAR				
.X $\pm .1$	$X^\circ \pm 1^\circ$	 TITLE: PERM-O-PAD TO-18 MOUNT			
.XX $\pm .01$					
.XXX $\pm .005$		DESIGNED: <b>Shane Irving</b>	DATE: <b>06/19/98</b>	PART NO: <b>123-050</b>	REVISION: <b>A</b>
		CHECKED: <b>D. Green</b>	DATE: <b>02/16/04</b>	CAGE CODE : <b>32559</b>	SHEET # <b>1 OF 1</b>
CAD GENERATED DOCUMENT, DO NOT MEASURE DRAWING.					