



# PHOTOCOUPLER PS9613, PS9613L

**1 Mbps, OPEN COLLECTOR OUTPUT, FOR GATE DRIVE INTERFACE  
INTELLIGENT POWER MODULE  
8-PIN DIP PHOTOCOUPLER**

–NEPOC Series–

## DESCRIPTION

The PS9613 and PS9613L are optically coupled isolators containing a GaAlAs LED on the input side and a photo diode and a signal processing circuit on the output side on one chip.

The PS9613 is in a plastic DIP (Dual In-line Package) and the PS9613L is lead bending type (Gull-wing) for surface mounting.

## FEATURES

- High common mode transient immunity ( $CM_H, CM_L = \pm 15 \text{ kV}/\mu\text{s}$  MIN.)
- High-speed response ( $t_{PHL} = 500 \text{ ns}$  MAX.,  $t_{PLH} = 750 \text{ ns}$  MAX.)
- Maximum propagation delays ( $t_{PLH} - t_{PHL} = 270 \text{ ns}$  TYP.)
- Pulse width distortion ( $|t_{PHL} - t_{PLH}| = 270 \text{ ns}$  TYP.)
- Ordering number of tape product: PS9613L-E3, E4: 1 000 pcs/reel
- Safety standards
  - UL approved: File No. E72422 (S)
  - VDE0884 approved (Option) : No.91877

## APPLICATIONS

- IPM Driver
- General purpose inverter

The information in this document is subject to change without notice. Before using this document, please confirm that this is the latest version.

★ PACKAGE DIMENSIONS (UNIT: mm)

DIP Type

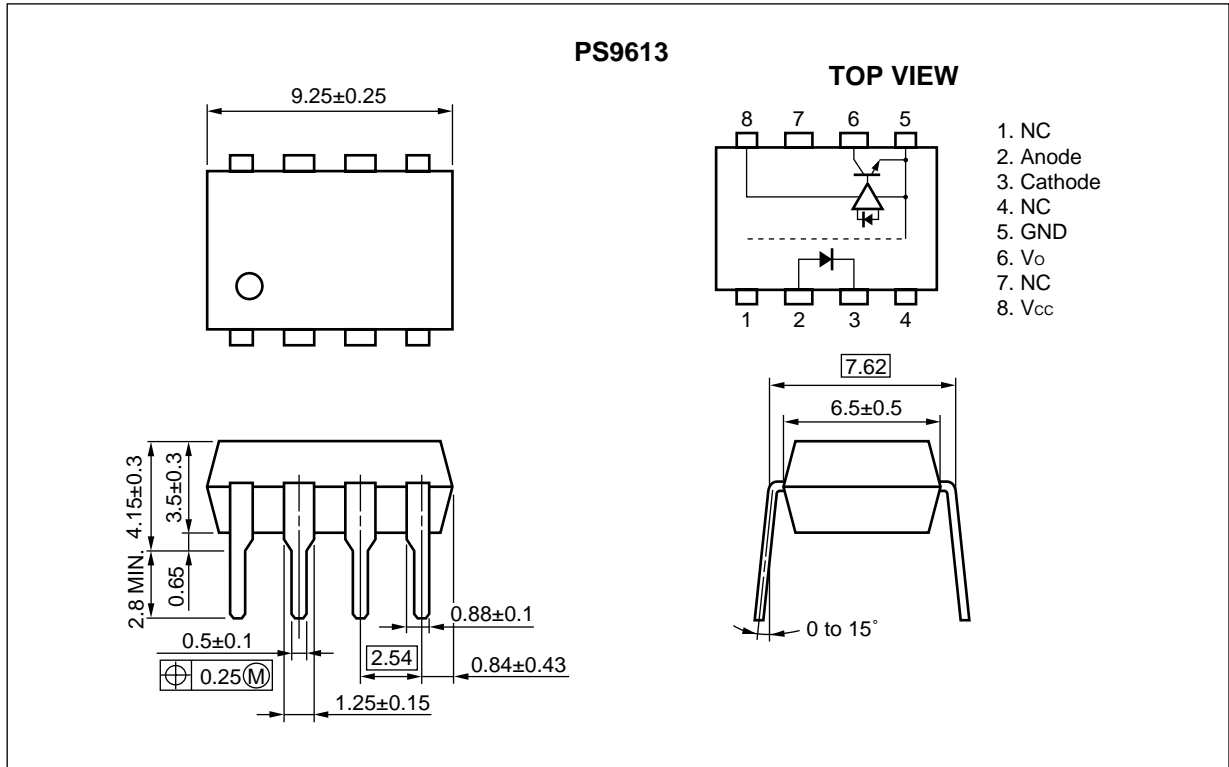

Lead Bending Type

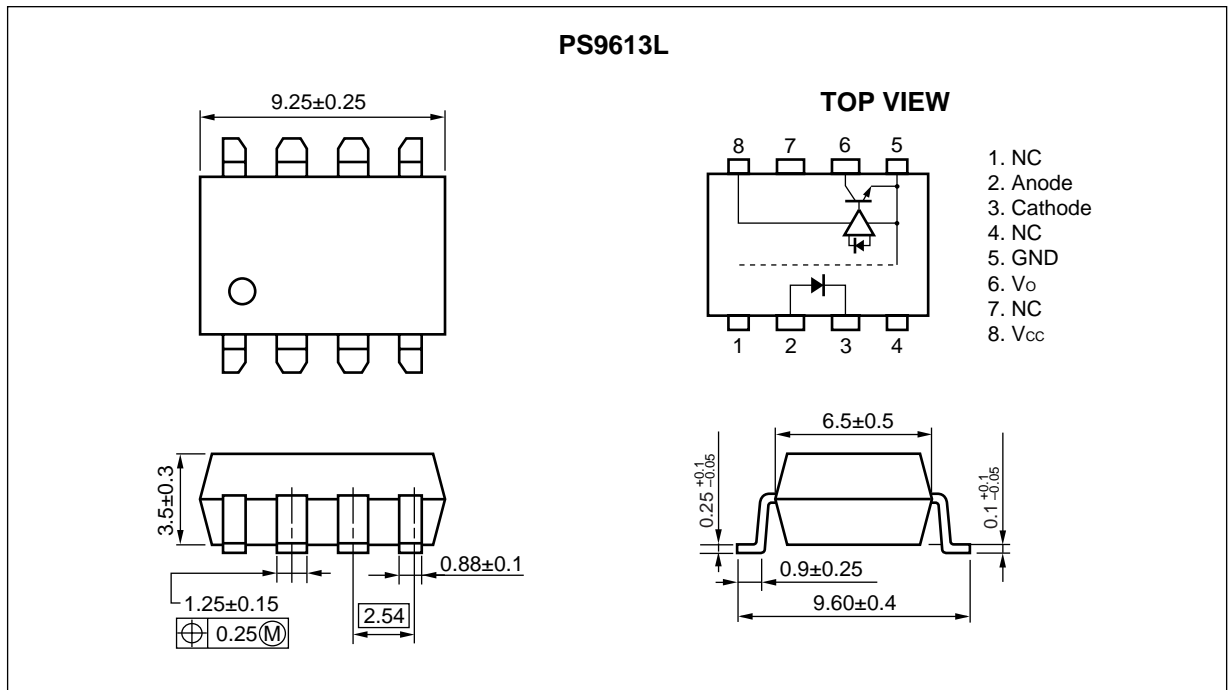

**FUNCTIONAL DIAGRAM**

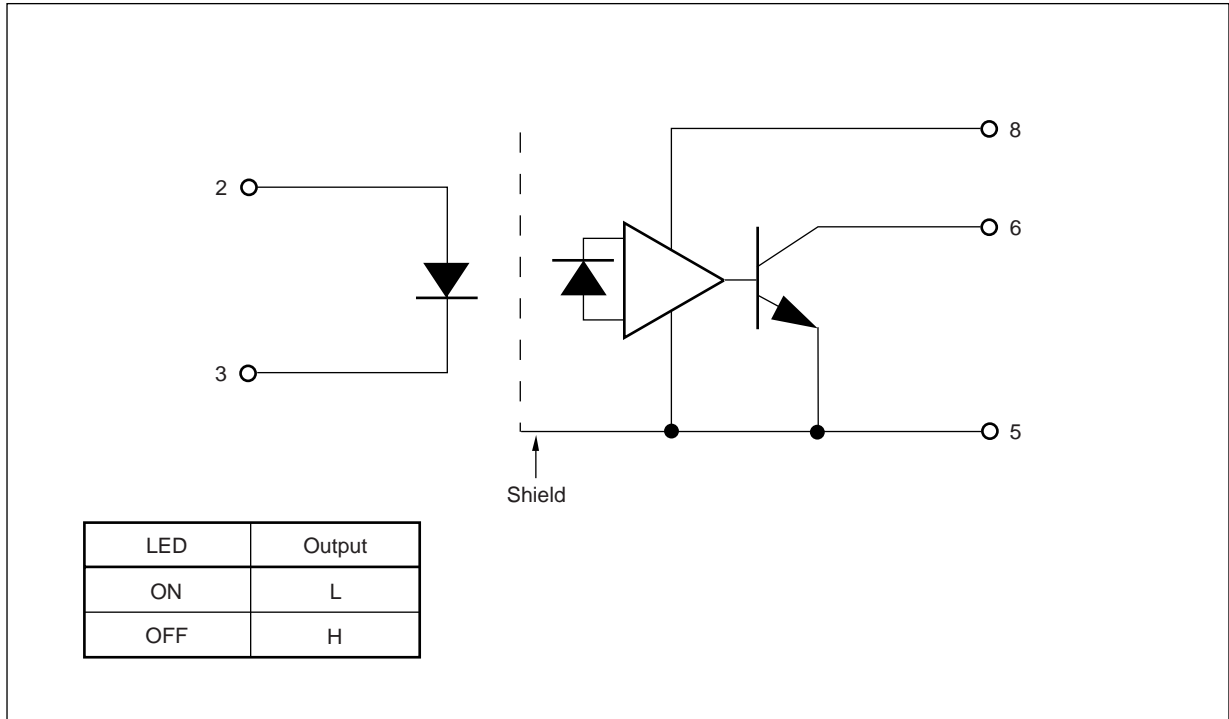

**MARKING EXAMPLE**

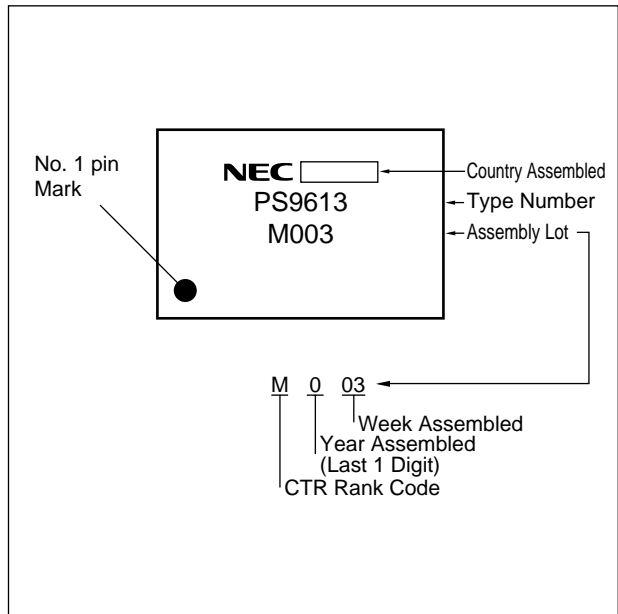

**ORDERING INFORMATION (Solder Contains Lead)**

Part Number	Package	Packing Style	Safety Standards Approval	Application Part Number <sup>*1</sup>	
PS9613	8-pin DIP	Magazine case 50 pcs	Approved products other than VDE	PS9613	
PS9613L				PS9613L	
PS9613L-E3		Embossed Tape 1 000 pcs/reel		VDE0884 approved (Option)	
PS9613L-E4					
PS9613-V		Magazine case 50 pcs	PS9613		
PS9613L-V			PS9613L		
PS9613L-V-E3		Embossed Tape 1 000 pcs/reel			
PS9613L-V-E4					

\*1 For the application of the Safety Standard, following part number should be used.

**ORDERING INFORMATION (Pb-Free)**

Part Number	Package	Packing Style	Safety Standards Approval	Application Part Number <sup>*1</sup>	
PS9613-A	8-pin DIP	Magazine case 50 pcs	Approved products other than VDE	PS9613	
PS9613L-A				PS9613L	
PS9613L-E3-A		Embossed Tape 1 000 pcs/reel		VDE0884 approved (Option)	
PS9613L-E4-A					
PS9613-V-A		Magazine case 50 pcs	PS9613		
PS9613L-V-A			PS9613L		
PS9613L-V-E3-A		Embossed Tape 1 000 pcs/reel			
PS9613L-V-E4-A					

\*1 For the application of the Safety Standard, following part number should be used.

**ABSOLUTE MAXIMUM RATINGS (T<sub>A</sub> = 25°C, unless otherwise specified)**

Parameter		Symbol	Ratings	Unit
Diode	Forward Current	I <sub>F</sub>	25	mA
	Reverse Voltage	V <sub>R</sub>	3.0	V
Detector	Supply Voltage	V <sub>CC</sub>	-0.5 to +35	V
	Output Voltage	V <sub>O</sub>	-0.5 to +35	V
	Output Current	I <sub>O</sub>	15	mA
	Power Dissipation	P <sub>C</sub>	100	mW
Isolation Voltage <sup>*1</sup>		BV	5 000	Vr.m.s.
Operating Ambient Temperature		T <sub>A</sub>	-40 to +100	°C
Storage Temperature		T <sub>stg</sub>	-55 to +125	°C

\*1 AC voltage for 1 minute at T<sub>A</sub> = 25°C, RH = 60% between input and output.

**RECOMMENDED OPERATING CONDITIONS**

Parameter	Symbol	MIN.	TYP.	MAX.	Unit
Forward Current	I <sub>F</sub>	10		20	mA
Output Voltage	V <sub>O</sub>	0		30	V
Supply Voltage	V <sub>CC</sub>	4.5	15	30	V
Input Voltage	V <sub>F</sub>	0		0.8	V

**ELECTRICAL CHARACTERISTICS (T<sub>A</sub> = -40 to +100°C, V<sub>CC</sub> = 15 V, unless otherwise specified)**

Parameter		Symbol	Conditions	MIN.	TYP. <sup>*1</sup>	MAX.	Unit
Diode	Forward Voltage	V <sub>F</sub>	I <sub>F</sub> = 10 mA	1.3	1.65	2.1	V
	Reverse Current	I <sub>R</sub>	V <sub>R</sub> = 3 V			200	μA
	Terminal Capacitance	C <sub>t</sub>	V = 0 V, f = 1 MHz, T <sub>A</sub> = 25°C		30		pF
Detector	Low Level Output Voltage	V <sub>OL</sub>	I <sub>F</sub> = 10 mA, V <sub>CC</sub> = 5 V, I <sub>OL</sub> = 2.4 mA		0.13	0.6	V
	High Level Output Current	I <sub>OH</sub>	V <sub>CC</sub> = 30 V, V <sub>F</sub> = 0.8 V		1.0	50	μA
	High Level Supply Current	I <sub>CCH</sub>	V <sub>CC</sub> = 30 V, V <sub>F</sub> = 0.8 V, V <sub>O</sub> = open		0.6	1.3	mA
	Low Level Supply Current	I <sub>CCL</sub>	V <sub>CC</sub> = 30 V, I <sub>F</sub> = 10 mA, V <sub>O</sub> = open		0.6	1.3	mA
Coupled	Threshold Input Current (H → L)	I <sub>FHL</sub>	V <sub>O</sub> = 0.8 V, I <sub>O</sub> = 0.75 mA		1.5	5.0	mA
	Current Transfer Ratio (I <sub>C</sub> /I <sub>F</sub> )	CTR	I <sub>F</sub> = 10 mA, V <sub>O</sub> = 0.6 V	44	110		%
	Isolation Resistance	R <sub>I-O</sub>	V <sub>I-O</sub> = 1 kV <sub>DC</sub> , R <sub>H</sub> = 40 to 60%, T <sub>A</sub> = 25°C	10 <sup>11</sup>			Ω
	Isolation Capacitance	C <sub>I-O</sub>	V = 0 V, f = 1 MHz, T <sub>A</sub> = 25°C		0.6		pF
	Propagation Delay Time (H → L) <sup>*2</sup>	t <sub>PHL</sub>	I <sub>F</sub> = 10mA, R <sub>L</sub> = 20 kΩ, C <sub>L</sub> = 100 pF, V <sub>THHL</sub> = 1.5 V, V <sub>THLH</sub> = 2.0 V		250	500	ns
	Propagation Delay Time (L → H) <sup>*2</sup>	t <sub>PLH</sub>			520	750	
	Maximum Propagation Delays	t <sub>PLH</sub> -t <sub>PHL</sub>		-200	270	650	
	Pulse Width Distortion (PWD) <sup>*2</sup>	t <sub>PHL</sub> -t <sub>PLH</sub>			270	650	
	Common Mode Transient Immunity at High Level Output <sup>*3</sup>	CM <sub>H</sub>	T <sub>A</sub> = 25°C, I <sub>F</sub> = 0 mA, V <sub>O</sub> > 3.0 V, V <sub>CM</sub> = 1.5 kV, R <sub>L</sub> = 20 kΩ, C <sub>L</sub> = 100 pF	15			kV/μs
Common Mode Transient Immunity at Low Level Output <sup>*3</sup>	CM <sub>L</sub>	T <sub>A</sub> = 25°C, I <sub>F</sub> = 10 mA, V <sub>O</sub> < 1.0 V, V <sub>CM</sub> = 1.5 kV, R <sub>L</sub> = 20 kΩ, C <sub>L</sub> = 100 pF	15			kV/μs	

\*1 Typical values at  $T_A = 25^\circ\text{C}$ .

\*2 Test circuit for propagation delay time

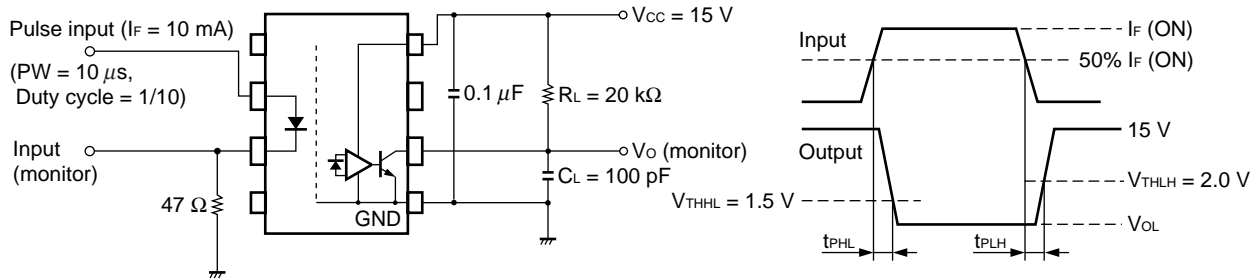

$C_L$  includes probe and stray wiring capacitance.

\*3 Test circuit for common mode transient immunity

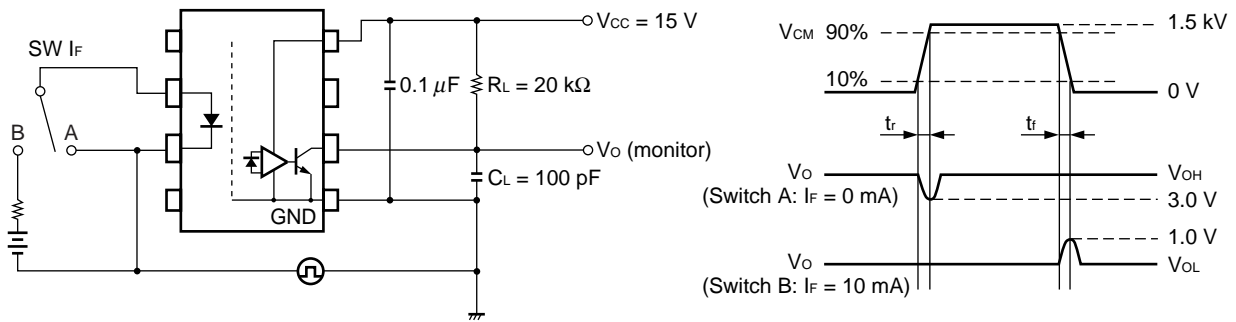

$C_L$  includes probe and stray wiring capacitance.

**USAGE CAUTIONS**

1. This product is weak for static electricity by designed with high-speed integrated circuit so protect against static electricity when handling.
2. By-pass capacitor of more than  $0.1 \mu\text{F}$  is used between  $V_{cc}$  and GND near device. Also, ensure that the distance between the leads of the photocoupler and capacitor is no more than 10 mm.
- ★ 3. Avoid storage at a high temperature and high humidity.

**TYPICAL CHARACTERISTICS ( $T_A = 25^\circ\text{C}$ , unless otherwise specified)**

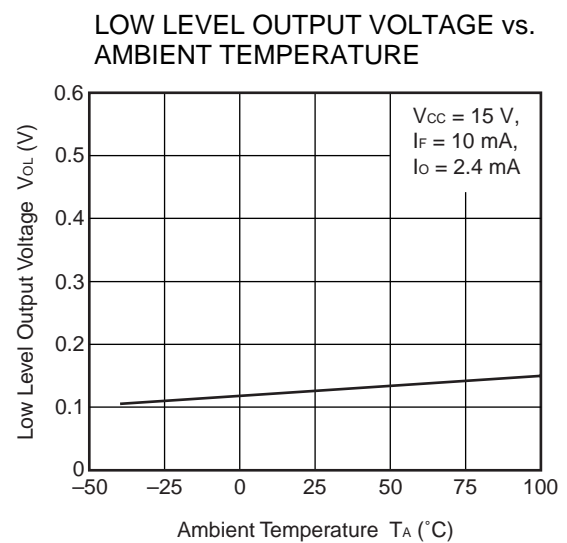
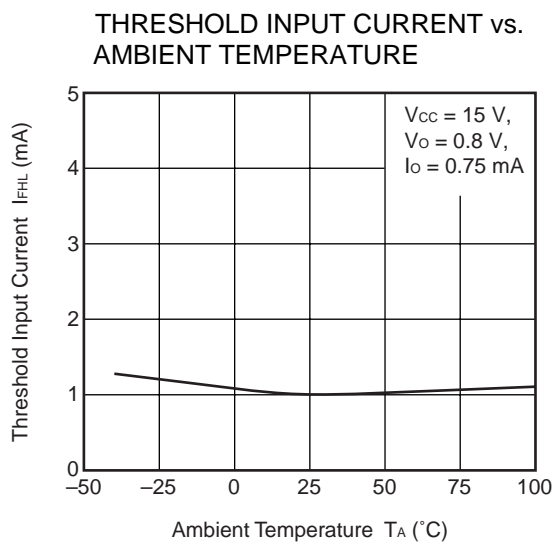
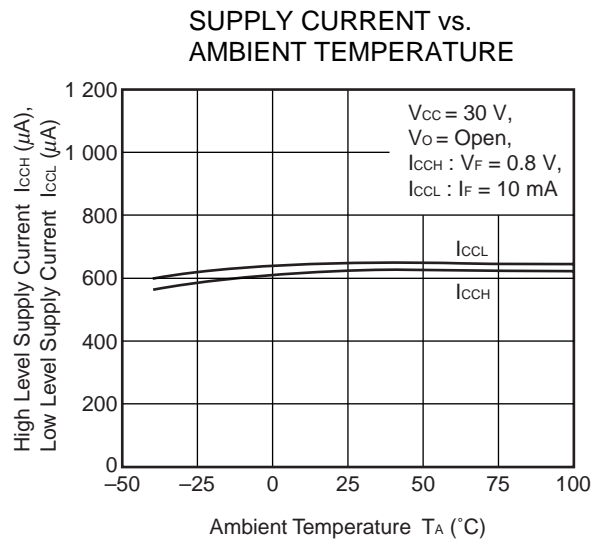
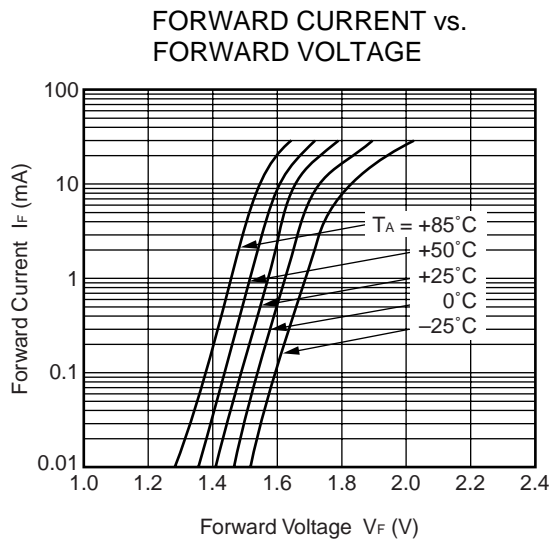
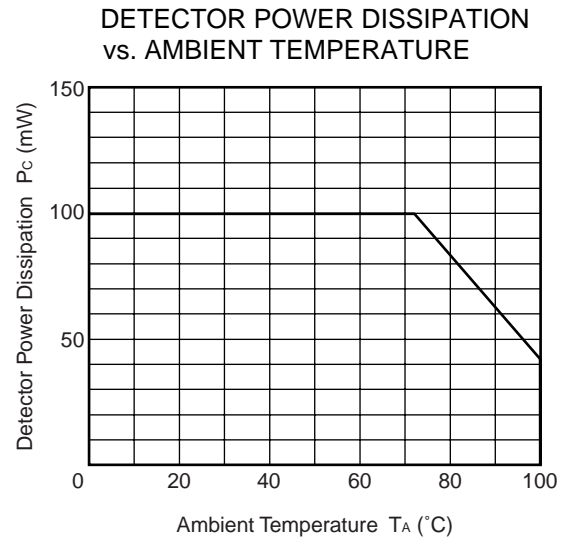
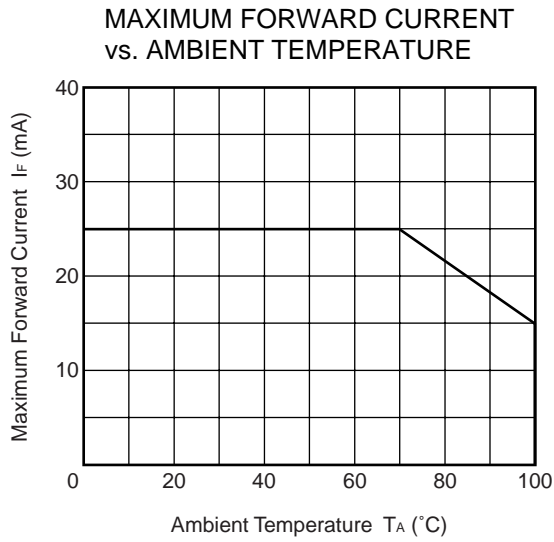



OUTPUT CURRENT vs. FORWARD CURRENT

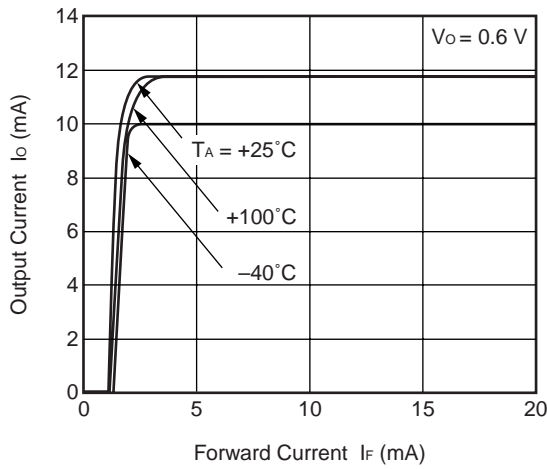

OUTPUT CURRENT vs. AMBIENT TEMPERATURE

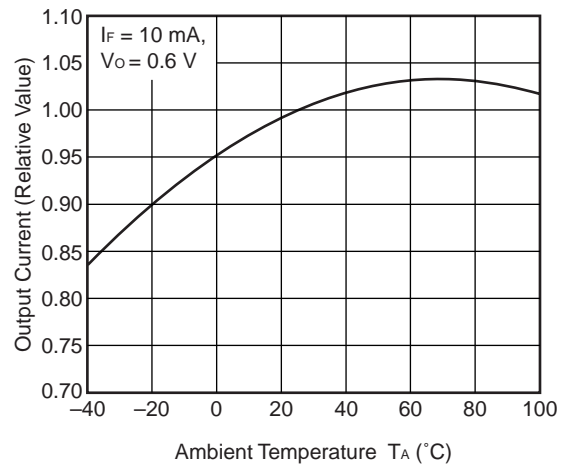

PROPAGATION DELAY TIME, MAXIMUM PROPAGATION DELAYS vs. FORWARD CURRENT

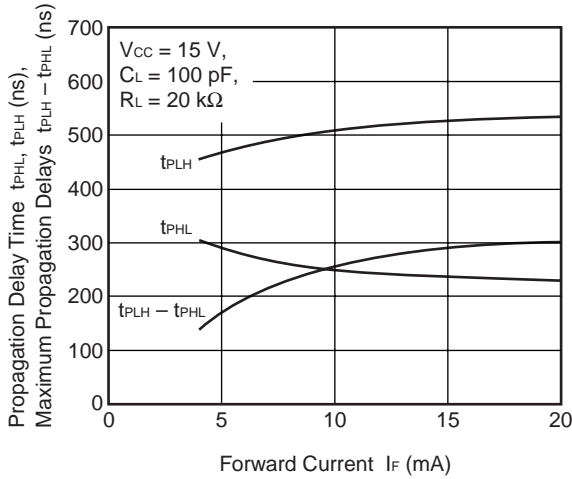

PROPAGATION DELAY TIME, MAXIMUM PROPAGATION DELAYS vs. SUPPLY VOLTAGE

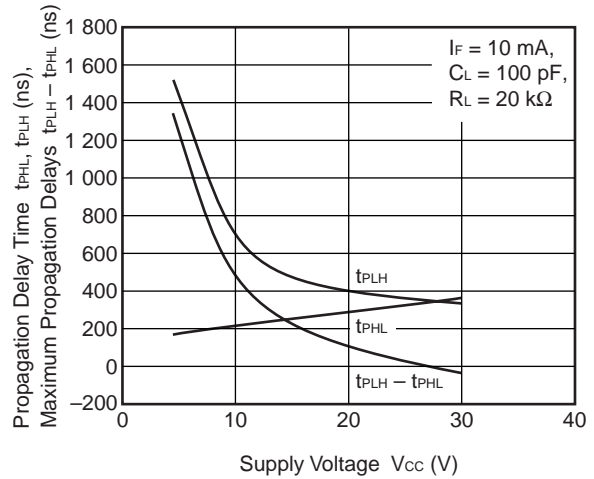

PROPAGATION DELAY TIME, PULSE WIDTH DISTORTION vs. AMBIENT TEMPERATURE

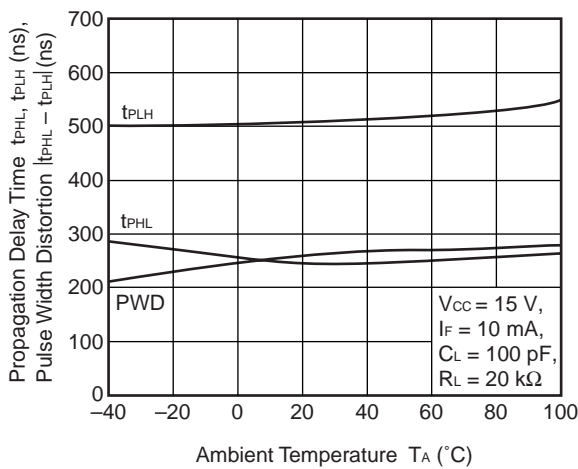

PROPAGATION DELAY TIME vs. LOAD CAPACITANCE

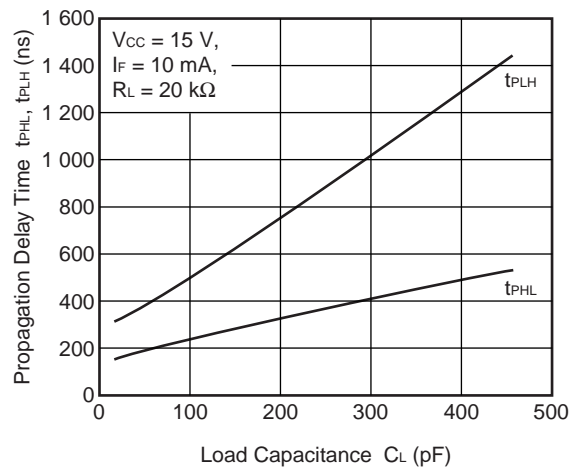

PROPAGATION DELAY TIME,  
MAXIMUM PROPAGATION DELAYS  
vs. LOAD RESISTANCE

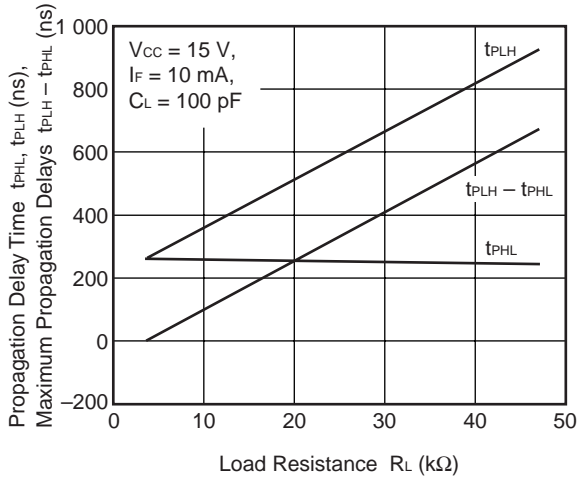

PROPAGATION DELAY TIME,  
MAXIMUM PROPAGATION DELAYS  
vs. LOAD RESISTANCE

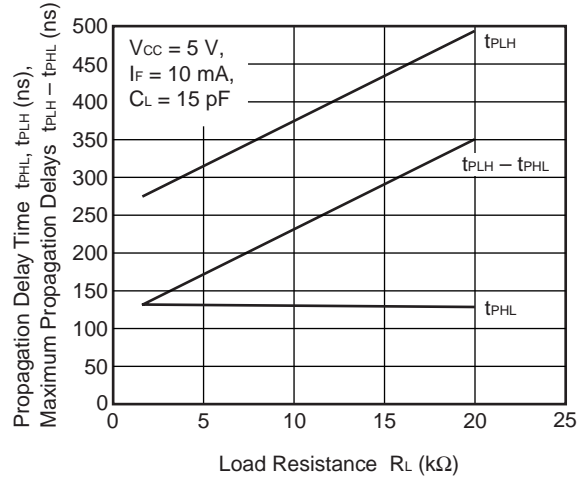

**Remark** The graphs indicate nominal characteristics.

★ TAPING SPECIFICATIONS (UNIT: mm)

Outline and Dimensions (Tape)

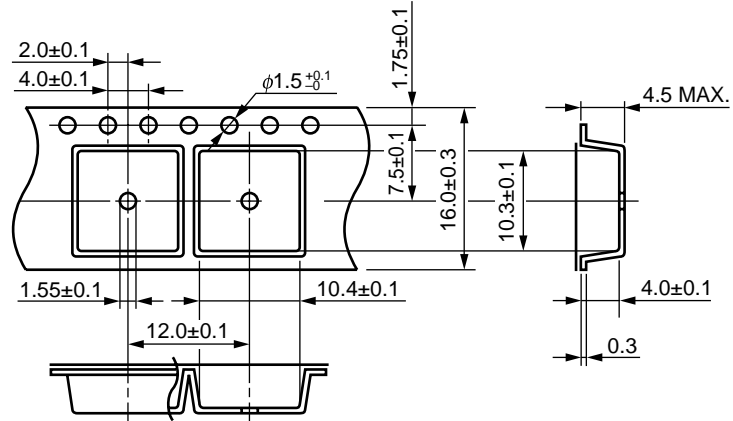

Tape Direction

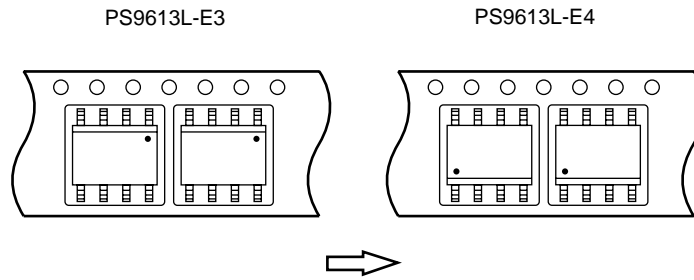

Outline and Dimensions (Reel)

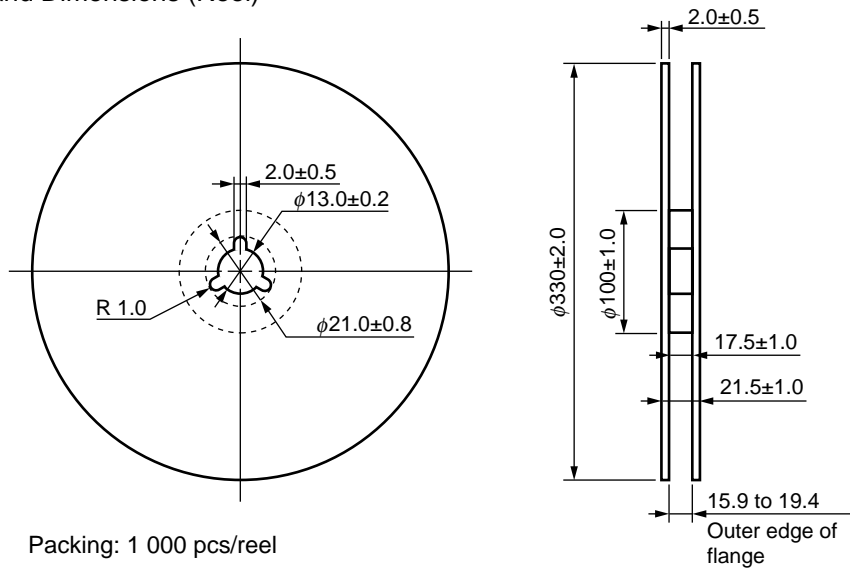

**NOTES ON HANDLING**

**1. Recommended soldering conditions**

**(1) Infrared reflow soldering**

- Peak reflow temperature 260°C or below (package surface temperature)
- Time of peak reflow temperature 10 seconds or less
- Time of temperature higher than 220°C 60 seconds or less
- Time to preheat temperature from 120 to 180°C 120±30 s
- Number of reflows Three
- Flux Rosin flux containing small amount of chlorine (The flux with a maximum chlorine content of 0.2 Wt% is recommended.)

Recommended Temperature Profile of Infrared Reflow

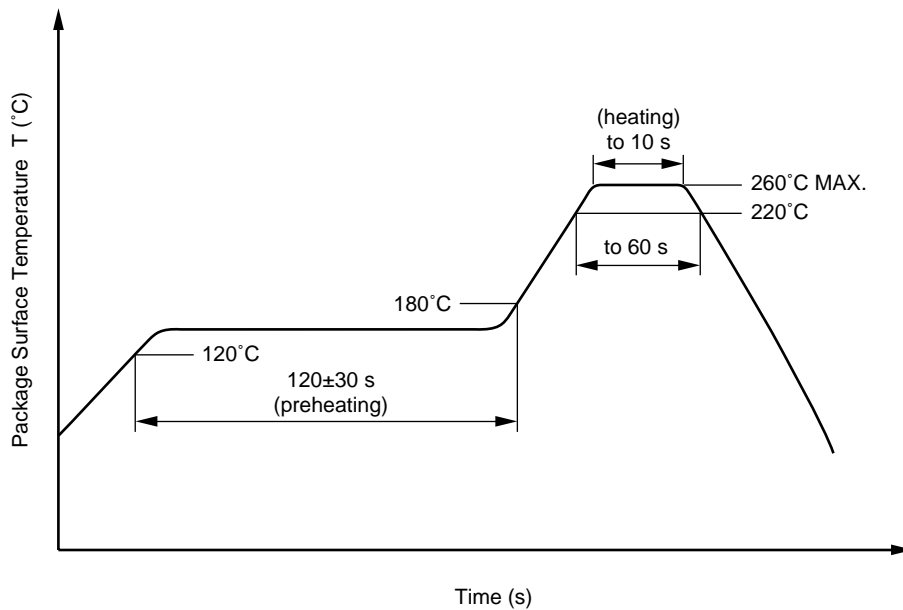

**(2) Wave soldering**

- Temperature 260°C or below (molten solder temperature)
- Time 10 seconds or less
- Preheating conditions 120°C or below (package surface temperature)
- Number of times One (Allowed to be dipped in solder including plastic mold portion.)
- Flux Rosin flux containing small amount of chlorine (The flux with a maximum chlorine content of 0.2 Wt% is recommended.)

**(3) Cautions**

- Fluxes  
Avoid removing the residual flux with freon-based and chlorine-based cleaning solvent.

★ **2. Cautions regarding noise**

Be aware that when voltage is applied suddenly between the photocoupler's input and output or between collector-emitters at startup, the output side may enter the on state, even if the voltage is within the absolute maximum ratings.

Subject: Compliance with EU Directives

CEL certifies, to its knowledge, that semiconductor and laser products detailed below are compliant with the requirements of European Union (EU) Directive 2002/95/EC Restriction on Use of Hazardous Substances in electrical and electronic equipment (RoHS) and the requirements of EU Directive 2003/11/EC Restriction on Penta and Octa BDE.

CEL Pb-free products have the same base part number with a suffix added. The suffix –A indicates that the device is Pb-free. The –AZ suffix is used to designate devices containing Pb which are exempted from the requirement of RoHS directive (\*). In all cases the devices have Pb-free terminals. All devices with these suffixes meet the requirements of the RoHS directive.

This status is based on CEL’s understanding of the EU Directives and knowledge of the materials that go into its products as of the date of disclosure of this information.

Restricted Substance per RoHS	Concentration Limit per RoHS (values are not yet fixed)	Concentration contained in CEL devices	
		-A	-AZ
Lead (Pb)	< 1000 PPM	Not Detected	(*)
Mercury	< 1000 PPM	Not Detected	
Cadmium	< 100 PPM	Not Detected	
Hexavalent Chromium	< 1000 PPM	Not Detected	
PBB	< 1000 PPM	Not Detected	
PBDE	< 1000 PPM	Not Detected	

If you should have any additional questions regarding our devices and compliance to environmental standards, please do not hesitate to contact your local representative.

**Important Information and Disclaimer:** Information provided by CEL on its website or in other communications concerning the substance content of its products represents knowledge and belief as of the date that it is provided. CEL bases its knowledge and belief on information provided by third parties and makes no representation or warranty as to the accuracy of such information. Efforts are underway to better integrate information from third parties. CEL has taken and continues to take reasonable steps to provide representative and accurate information but may not have conducted destructive testing or chemical analysis on incoming materials and chemicals. CEL and CEL suppliers consider certain information to be proprietary, and thus CAS numbers and other limited information may not be available for release.

In no event shall CEL’s liability arising out of such information exceed the total purchase price of the CEL part(s) at issue sold by CEL to customer on an annual basis.

See CEL Terms and Conditions for additional clarification of warranties and liability.