

KLC-50 B

KLC-50 B is a high bright InGaN blue LED, and has the optimized optical characteristics.

Features

- Transparent epoxy lens
- High Optical Output

Applications

- Display
- Indicator
- Signage

DIMENSIONS

Unit : [mm]

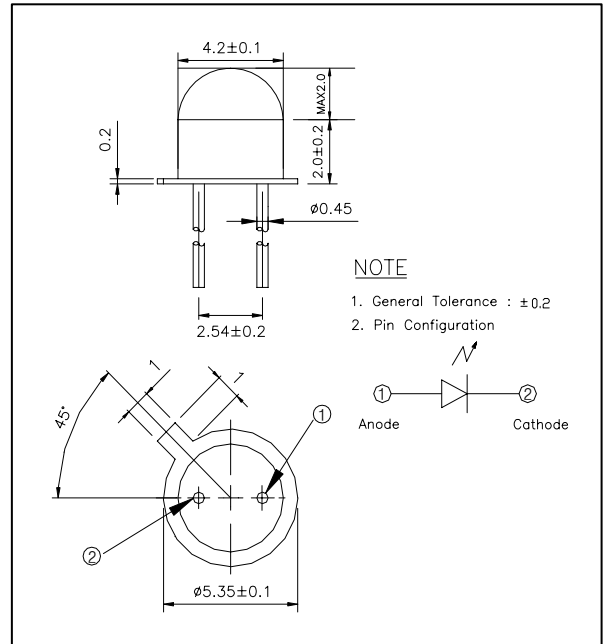

Maximum Ratings

[Ta=25°C]

Parameter	Symbol	Ratings	Unit
Reverse voltage	V_R	5	V
Forward current	I_F	30	mA
Pulse forward current *1	I_{FP}	0.5	A
Power dissipation	P_D	105	mW
Operating temperature	$T_{opr.}$	-30 ~ +85	°C
Storage temperature	$T_{stg.}$	-40 ~ +100	°C
Soldering Temperature *2	$T_{sol.}$	260	°C

*1. I_{FP} Measured under duty $\frac{1}{10}$ @ 1KHz

*2. Soldering time $\frac{1}{2}$ Sec

Keep the distance more than 3mm from soldering foundation.

Electro-Optical Characteristics

[Ta=25°C]

Parameter	Symbol	Conditions	Min	Typ	Max	Unit
Forward voltage	V_F	$I_F = 20$ mA	-	3.2	3.5	V
Reverse current	I_R	$V_R = 5$ V	-	-	10	uA
Luminous Intensity	I_v	$I_F = 20$ mA	90	120	150	mcd
Doninant Wave Length	λ_d	$I_F = 20$ mA	465	470	475	nm
Spectral half bandwidth	$\Delta\lambda$	$I_F = 20$ mA	-	25	-	nm
Half angle	$2\Delta\theta_{1/2}$	$I_F = 20$ mA	-	180	-	deg.

KLC-50 B

Forward current vs. Ambient temperature

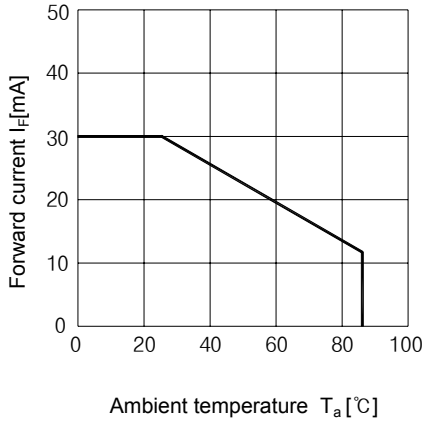

Radiant Intensity vs. Forward current

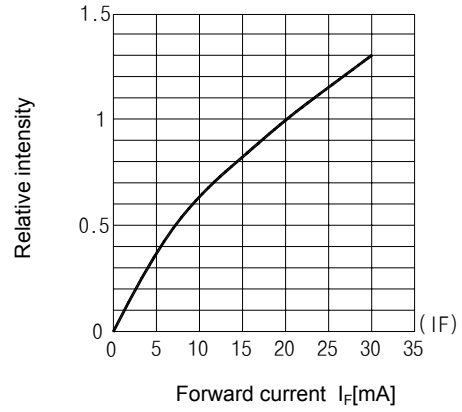

Relative radiant intensity vs. Ambient temperature

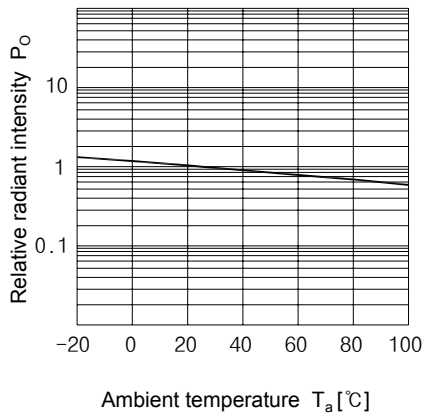

Relative intensity vs. Wavelength

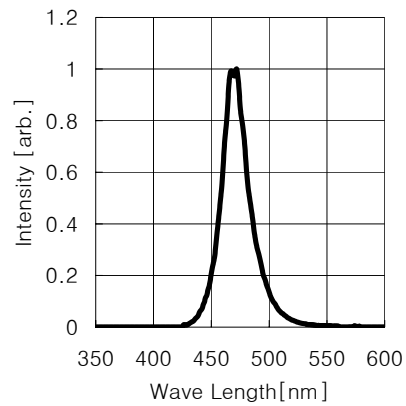

Forward current vs. Forward voltage

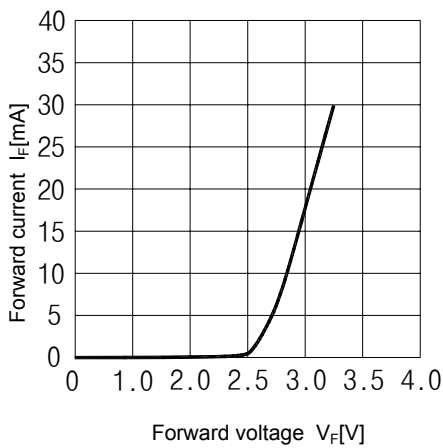

Radiant Pattern

