

To all our customers

---

**Regarding the change of names mentioned in the document, such as Hitachi Electric and Hitachi XX, to Renesas Technology Corp.**

---

The semiconductor operations of Mitsubishi Electric and Hitachi were transferred to Renesas Technology Corporation on April 1st 2003. These operations include microcomputer, logic, analog and discrete devices, and memory chips other than DRAMs (flash memory, SRAMs etc.) Accordingly, although Hitachi, Hitachi, Ltd., Hitachi Semiconductors, and other Hitachi brand names are mentioned in the document, these names have in fact all been changed to Renesas Technology Corp. Thank you for your understanding. Except for our corporate trademark, logo and corporate statement, no changes whatsoever have been made to the contents of the document, and these changes do not constitute any alteration to the contents of the document itself.

Renesas Technology Home Page: <http://www.renesas.com>

Renesas Technology Corp.  
Customer Support Dept.  
April 1, 2003

## Cautions

Keep safety first in your circuit designs!

1. Renesas Technology Corporation puts the maximum effort into making semiconductor products better and more reliable, but there is always the possibility that trouble may occur with them. Trouble with semiconductors may lead to personal injury, fire or property damage.  
Remember to give due consideration to safety when making your circuit designs, with appropriate measures such as (i) placement of substitutive, auxiliary circuits, (ii) use of nonflammable material or (iii) prevention against any malfunction or mishap.

Notes regarding these materials

1. These materials are intended as a reference to assist our customers in the selection of the Renesas Technology Corporation product best suited to the customer's application; they do not convey any license under any intellectual property rights, or any other rights, belonging to Renesas Technology Corporation or a third party.
2. Renesas Technology Corporation assumes no responsibility for any damage, or infringement of any third-party's rights, originating in the use of any product data, diagrams, charts, programs, algorithms, or circuit application examples contained in these materials.
3. All information contained in these materials, including product data, diagrams, charts, programs and algorithms represents information on products at the time of publication of these materials, and are subject to change by Renesas Technology Corporation without notice due to product improvements or other reasons. It is therefore recommended that customers contact Renesas Technology Corporation or an authorized Renesas Technology Corporation product distributor for the latest product information before purchasing a product listed herein.  
The information described here may contain technical inaccuracies or typographical errors. Renesas Technology Corporation assumes no responsibility for any damage, liability, or other loss rising from these inaccuracies or errors.  
Please also pay attention to information published by Renesas Technology Corporation by various means, including the Renesas Technology Corporation Semiconductor home page (<http://www.renesas.com>).
4. When using any or all of the information contained in these materials, including product data, diagrams, charts, programs, and algorithms, please be sure to evaluate all information as a total system before making a final decision on the applicability of the information and products. Renesas Technology Corporation assumes no responsibility for any damage, liability or other loss resulting from the information contained herein.
5. Renesas Technology Corporation semiconductors are not designed or manufactured for use in a device or system that is used under circumstances in which human life is potentially at stake. Please contact Renesas Technology Corporation or an authorized Renesas Technology Corporation product distributor when considering the use of a product contained herein for any specific purposes, such as apparatus or systems for transportation, vehicular, medical, aerospace, nuclear, or undersea repeater use.
6. The prior written approval of Renesas Technology Corporation is necessary to reprint or reproduce in whole or in part these materials.
7. If these products or technologies are subject to the Japanese export control restrictions, they must be exported under a license from the Japanese government and cannot be imported into a country other than the approved destination.  
Any diversion or reexport contrary to the export control laws and regulations of Japan and/or the country of destination is prohibited.
8. Please contact Renesas Technology Corporation for further details on these materials or the products contained therein.

# H8S/2633 Series

H8S/2633

HD6432633

H8S/2632

HD6432632

H8S/2631

HD6432631

H8S/2633 F-ZTAT™

HD64F2633

H8S/2633R F-ZTAT™

HD64F2633R

H8S/2695

HD6432695

Hardware Manual

**RENESAS**

ADE-602-165C

Rev. 4.0

8/29/02

Hitachi, Ltd.

## Cautions

1. Hitachi neither warrants nor grants licenses of any rights of Hitachi's or any third party's patent, copyright, trademark, or other intellectual property rights for information contained in this document. Hitachi bears no responsibility for problems that may arise with third party's rights, including intellectual property rights, in connection with use of the information contained in this document.
2. Products and product specifications may be subject to change without notice. Confirm that you have received the latest product standards or specifications before final design, purchase or use.
3. Hitachi makes every attempt to ensure that its products are of high quality and reliability. However, contact Hitachi's sales office before using the product in an application that demands especially high quality and reliability or where its failure or malfunction may directly threaten human life or cause risk of bodily injury, such as aerospace, aeronautics, nuclear power, combustion control, transportation, traffic, safety equipment or medical equipment for life support.
4. Design your application so that the product is used within the ranges guaranteed by Hitachi particularly for maximum rating, operating supply voltage range, heat radiation characteristics, installation conditions and other characteristics. Hitachi bears no responsibility for failure or damage when used beyond the guaranteed ranges. Even within the guaranteed ranges, consider normally foreseeable failure rates or failure modes in semiconductor devices and employ systemic measures such as fail-safes, so that the equipment incorporating Hitachi product does not cause bodily injury, fire or other consequential damage due to operation of the Hitachi product.
5. This product is not designed to be radiation resistant.
6. No one is permitted to reproduce or duplicate, in any form, the whole or part of this document without written approval from Hitachi.
7. Contact Hitachi's sales office for any questions regarding this document or Hitachi semiconductor products.

## General Precautions on the Handling of Products

### 1. Treatment of NC Pins

Note: Do not connect anything to the NC pins.

The NC (not connected) pins are either not connected to any of the internal circuitry; or are used as test pins or to reduce noise. If something is connected to the NC pins, the operation of the LSI is not guaranteed.

### 2. Treatment of Unused Input Pins

Note: Fix all unused input pins to high or low level.

Generally, the input pins of CMOS products are high-impedance input pins. If unused pins are in their open states, intermediate levels are induced by noise in the vicinity, a pass-through current flows internally, and a malfunction may occur.

### 3. Processing before Initialization

Note: When power is first supplied, the product's state is undefined. The states of internal circuits are undefined until full power is supplied throughout the chip and a low level is input on the reset pin. During the period where the states are undefined, the register settings and the output state of each pin are also undefined. Design your system so that it does not malfunction because of processing while it is in this undefined state. For those products which have a reset function, reset the LSI immediately after the power supply has been turned on.

### 4. Prohibition of Access to Undefined or Reserved Address

Note: Access to undefined or reserved addresses is prohibited.

The undefined or reserved addresses may be used to expand functions, or test registers may have been allocated to these addresses. Do not access these registers: the system's operation is not guaranteed if they are accessed.

 RENESAS

## Preface

These LSIs are high-performance microcomputers with a 32-bit H8S/2600 CPU core and a variety of built-in peripheral functions necessary for a system configuration.

The built-in peripheral devices include a 16-bit timer pulse unit (TPU), a programmable pulse generator (PPG)\*<sup>1</sup>, a watchdog timer (WDT), 8-bit timers, a 14-bit PWM timer (PWM)\*<sup>1</sup>, serial communication interfaces (SCI, IrDA)\*<sup>1</sup>, an A/D converter, a D/A converter\*<sup>1</sup>, and I/O ports. An I<sup>2</sup>C bus interface (IIC)\*<sup>1</sup> can also be incorporated as an option. An on-chip DMA controller (DMAC)\*<sup>1</sup> and data transfer controller (DTC) perform high-speed data transfer without using the CPU, enabling use of these LSIs as embedded microcomputers in various advanced control systems. Two types of internal ROM-flash memory (F-ZTAT™\*<sup>2</sup>) and mask ROM-are available, providing a quick and flexible response to conditions from ramp-up through full-scale volume production, even for applications with frequently changing specifications.

Notes: \*1 This function is not available in the H8S/2695.

\*2 F-ZTAT is a trademark of Hitachi, Ltd.

**Target Users:** This manual was written for users who will be using the H8S/2633 Series, H8S/2633R, or H8S/2695 in the design of application systems. Readers are expected to understand the fundamentals of electrical circuits, logic circuits, and microcomputers.

**Objective:** This manual was written to provide users with an explanation of the hardware functions and electrical characteristics of the H8S/2633 Series, H8S/2633R, and H8S/2695. Refer to the H8S/2600 Series, H8S/2000 Series Programming Manual for a detailed description of the instruction set.

**Notes on reading this manual:**

- In order to understand the overall functions of the chip  
Read the manual according to the contents. This manual is broadly divided into parts covering the CPU, system control functions, peripheral functions, and electrical characteristics.
- In order to understand the details of the CPU's functions  
Refer to the H8S/2600 Series, H8S/2000 Series Programming Manual.

**Example:** Bit order: The MSB is on the left and the LSB is on the right.

**Related Manuals:** The latest versions of all related manuals are available from our website. Please ensure that you have the latest versions of all documents you require.  
<http://www.hitachisemiconductor.com/>

H8S/2633 Series manuals:

<b>Manual Title</b>	<b>ADE No.</b>
H8S/2633 Series Hardware Manual	This manual
H8S/2600 Series, H8S/2000 Series Programming Manual	ADE-602-083

Users manuals for development tools:

<b>Manual Title</b>	<b>ADE No.</b>
C/C++ Compiler, Assembler, Optimized Linkage Editor User's Manual	ADE-702-247
Simulator Debugger (for Windows) User's Manual	ADE-702-037
Hitachi Embedded Workshop User's Manual	ADE-702-201

Application Notes:

<b>Manual Title</b>	<b>ADE No.</b>
H8S Series Technical Q & A	ADE-502-059



## List of Items Revised or Added for This Version

Section	Page	Item	Description
Preface			Replaced
Comparison of H8S/2633, H8S/2632, H8S/2631, H8S/2633F-ZTAT, H8S/2633RF-ZTAT, and H8S/2695 Product Specifications			Newly added
1.1 Overview	1		Note *2 added
	2 to 7	Table 1-1 Overview	CPU, 14-bit PWM timer (PWM), memory, interrupt controller, clock pulse generator descriptions added Notes *, *1 and *2 added Package description added Product lineup description replaced
1.2 Internal Block Diagram	8		Description added
	9	Figure 1-1 (b) H8S/2633R Internal Block Diagram	Newly added
	10	Figure 1-1 (c) H8S/2695 Internal Block Diagram	
1.3.1 Pin Arrangement	11		Description added
		Figure 1-2 (a) H8S/2633, H8S/2632, H8S/2631, H8S/2633F Pin Arrangement (TFP-120: Top View)	Description added to Note *
	12	Figure 1-2 (b) H8S/2633R Pin Arrangement (TFP-120: Top View)	Newly added
	13	Figure 1-3 (a) H8S/2633, H8S/2632, H8S/2631, H8S/2633F Pin Arrangement (FP-120B: Top View)	Package name amended from FP-128 to FP-128B Description added to Note *
	15	Figure 1-3 (b) H8S/2633R Pin Arrangement (FP-128B: Top View)	Newly added
	16	Figure 1-3 (c) H8S/2695 Pin Arrangement (FP-128B: Top View)	
1.3.2 Pin Functions in Each Operating Mode	17		Description added
		Table 1-2 (a) Pin Functions in Each Operating Mode (H8S/2633, H8S/2632, H8S/2631, H8S/2633F)	Pin numbers amended from FP-128 to FP-128B

Section	Page	Item	Description
1.3.2 Pin Functions in Each Operating Mode	18		Note * added to FEW pin
	22 to 26	Table 1-2 (b) Pin Functions in Each Operating Mode (H8S/2633R)	Newly added
	27 to 31	Table 1-2 (c) Pin Functions in Each Operating Mode (H8S/2695)	
1.3.3 Pin Functions	32		Description added
	38 to 43	Table 1-3 (b) Pin Functions (H8S/2633R)	Newly added
	44 to 48	Table 1-3 (c) Pin Functions (H8S/2695)	
2.1.1 Features	50	• High-speed operation	Description added
2.8.5 Bus-Released State	90		Note * added
2.8.6 Power-Down State	90		Description added
			Notes *1 and *2 added
3.2.2 System Control Register (SYSCR)	98	Bit 2—Manual Reset Selection Bit (MRESE)	Note * added
		Bit 0—RAM Enable (RAME)	
3.2.3 Pin Function Control Register (PFCR)	100	Bit 5—BUZZ Output Enable (BUZZE)	
		Bit 4—LCAS Output Pin Selection Bit (LCASS)	
3.5 Address Map in Each Operating Mode	103		Description added 16 kbytes amended to 16 Mbytes
	104	Figure 3-1 Memory Map in Each Operating Mode in the H8S/2633, H8S/2633R	Address map for H8S/2633R operating modes newly added
	107	Figure 3-4 Memory Map in Each Operating Mode in the H8S/2695	Newly added
4.1.3 Exception Vector Table	111	Table 4-2 Exception Vector Table	Note *3 amended
4.2.5 State of On-Chip Supporting Modules after Reset Release	115		Note * added

Section	Page	Item	Description
4.4	Interrupts	117	Note * added
		Figure 4-4	Interrupt Sources and Number of Interrupts
			Note *3 added
5.1.1	Features	121	• DTC and DMAC control
5.2.2	Interrupt Priority Registers A to L, O (IPRA to IPRL, IPRO)	125	Table 5-3 Correspondence between Interrupt Sources and IPR Settings
5.2.5	IRQ Status Register (ISR)	128	Bits 7 to 0—IRQ7 to IRQ0 flags (IRQ7F to IRQ0F)
			Note * added (n = 5 to 0) amended to (n = 7 to 0)
5.3.1	External Interrupts	129	IRQ7 to IRQ0 Interrupts IRQ5 to IRQ0 amended to IRQ7 to IRQ0
5.3.2	Internal Interrupts	130	Notes *1 and *2 added
5.3.3	Interrupt Exception Handling Vector Table	131 to 134	Table 5-4(a) Interrupt Sources, Vector Addresses, and Interrupt Priorities (H8S/2633, H8S/2632, H8S/2631, H8S/2633R)
			H8S/2633R added Amend as follows: Interrupt Source column: "CMI" → "Reserved" Origin of Interrupt Source column: "Refresh timer" → "___"
		135 to 138	Table 5-4(b) Interrupt Sources, Vector Addresses, and Interrupt Priorities (H8S/2695)
			Newly added
5.6	DTC and DMAC Activation by Interrupt (DMAC and DTC functions are not available in the H8S/2695)	150	Title amended
5.6.2	Block Diagram	151	Figure 5-9 Interrupt Control for DTC and DMAC
5.6.3	Operation (DMAC and DTC functions are not available in the H8S/2695)	152	Table 5-11 Interrupt Source Selection and Clearing Control
			(4) Notes on Use
			Note *1 added Note * added

Section	Page	Item	Description
Section 6 PC Break Controller (PBC) (This function is not available in the H8S/2695)	153		Title amended
7.1 Overview	165		Note * added
7.1.1 Features	165, 166		
7.1.2 Block Diagram	167	Figure 7-1 Block Diagram of Bus Controller	
7.1.3 Pin Configuration	168	Table 7-1 Bus Controller Pins	
7.1.4 Register Configuration	169	Table 7-2 Bus Controller Registers	Note *3 added
7.2.4 Bus Control Register H (BCRH)	175		Note * added
	177	Bits 2 to 0—RAM Type Select (RMTS2 to RMTS0)	
7.2.5 Bus Control Register L (BCRL)	178		
7.2.6 Pin Function Control Register (PFCR)	180		
7.2.7 Memory Control Register (MCR)	183		
7.2.8 DRAM Control Register (DRAMCR)	185		Self-refresh amended to refresh control (RFSHE = 1)
		Bits 2 to 0—Refresh Counter Clock Select (CKS2 to CKS0)	Note * added
7.2.9 Refresh Timer Counter (RTCNT)	187		
7.2.10 Refresh Time Constant Register (RTCOR)			
7.3 Overview of Bus Control	188 to 192		
7.3.2 Bus Specifications	189	(1) Bus Width	Amended from ADWCR to ABWCR

<b>Section</b>	<b>Page</b>	<b>Item</b>	<b>Description</b>
7.5 DRAM Interface (This function is not available in the H8S/2695)	206		Title amended
7.6 DMAC Single Address Mode and DRAM Interface (This function is not available in the H8S/2695)	223		
7.11 Bus Arbitration (DMAC and DTC functions are not available in the H8S/2695)	238		
7.11.3 Bus Transfer Timing	239		Description of CPU amended
7.12 Resets and the Bus Controller	239		Note * added
Section 8 DMA Controller (DMAC) (This function is not available in the H8S/2695)	241		Title amended
Section 9 Data Transfer Controller (DTC) (This function is not available in the H8S/2695)	329		
9.2.9 Module Stop Control Register A (MSTPCRA)	338		Description amended
9.5 Usage Notes	359		Description added
Section 10A I/O Ports (H8S/2633, H8S/2632, H8S/2631, H8S/2633R)	361		Title amended
10A.3.3 Pin Functions	384	Table 10A-5 Port 3 Pin Functions	Last portion of selection method and pin functions table for P35/SCK1/SCK4/SCL0/IRQ5 replaced
10A.5.1 Overview	389	Figure 10A-4 Port 7 Pin Functions	Title amended

Section	Page	Item	Description
10A.7.1 Overview	397		6-bit I/O port amended to 4-bit I/O port
10A.12.3 Pin Functions	429, 430	Table 10A-21 Port F Pin Functions	TMTS0 amended to RMTS0 in note * to pins PF6/AS/LCAS and PF2/LCAS/WAIT/BREQ0
Section 10B (H8S/2695) I/O Ports	437 to 510		Newly added
11.1.1 Features	512		Note * added
	514	Table 11-1 TPU Functions	
11.2.5 Timer Status Register (TSR)	545, 546	Bit 3—Input Capture/Output Compare Flag D (TGFD), Bit 2—Input Capture/Output Compare Flag C (TGFC), Bit 1—Input Capture/Output Compare Flag B (TGFB), Bit 0—Input Capture/Output Compare Flag A (TGFA)	
11.2.9 Timer Synchro Register (TSYR)	550		Channels 0 to 4 amended to channels 0 to 5
11.4.2 Basic Functions	557	Figure 11-8 Periodic Counter Operation	Note * added
11.5.1 Interrupt Sources and Priorities	582	Table 11-13 TPU Interrupts	
11.5.2 DTC/DMAC Activation (This function is not available in the H8S/2695)	583		Title amended
11.6.1 Input/Output Timing	585	Output Compare Output Timing	(TIOC pin) added
11.6.2 Interrupt Signal Timing	591	Status Flag Clearing Timing Figure 11-47 Timing for Status Flag Clearing by DTC or DMAC Activation	Note * added
11.7 Usage Notes	601	Interrupts and Module Stop Mode	The DTC amended to DMAC and DTC activation source and Note * added

Section	Page	Item	Description
Section 12 Programmable Pulse Generator (PPG) (This function is not available in the H8S/2695)	603		Title amended
12.2.1 Next Data Enable Registers H and L (NDERH, NDERL)	608	NDERL Bits 7 to 0—Next Data Enable 7 to 0 (NDER7 to NDER0)	Description added
Section 13 8-Bit Timers (TMR) (This function is not available in the H8S/2695)	629		Title amended
13.3.5 Operation with Cascaded Connection	645		Description amended
13.4.1 Interrupt Sources and DTC Activation (The H8S/2695 does not have a DTC function or an 8-bit timer)	646		Title amended
Section 14 14-Bit PWM D/A (This function is not available in the H8S/2695)	655		
Section 15 Watchdog Timer (WDT1 is not available in the H8S/2695)	671		
15.1.1 Features	671		Note * added
15.1.2 Block Diagram	673	Figure 15-1 (b) Block Diagram	Description added to note of WDT1
15.1.3 Pin Configuration	674	Table 15-1 WDT Pin	Note * added
15.2.2 Timer Control/Status Register (TCSR)	675 676	TCSR1 Bit 6—Timer Mode Select (WT/IT) Bit 7—Overflow Flag (OVF)	Note *1 added Note * added Description added

Section	Page	Item	Description
15.2.2 Timer Control/Status Register (TCSR)	677	WDT1 Mode Select	Note * added
		WDT0 TCSR Bit 4—Reserve bit	Note added
	678	WDT1 TCSR Bit 4—Prescaler Select (PSS)	
	679	Bits 2 to 0—Clock Select 2 to 0 (CKS2 to CKS0)	
15.2.3 Reset Control/Status Register (RSTCSR)	680	WDT1 Input Clock Select	Note *1 added
15.2.3 Reset Control/Status Register (RSTCSR)	680	Bit 7—Watchdog Overflow Flag (WOVF)	TCSR amended to RSTCSR in bit table description
15.2.4 Pin Function Control Register (PFCR)	681		Note * added to bit table
		Bit 5—BUZZ Output Enable (BUZZE)	Note added
15.3.3 Timing of Setting Overflow Flag (OVF)	686		Note * added
15.5.5 Internal Reset in Watchdog Timer Mode	689		Description amended
15.5.6 OVF Flag Clearing in Interval Timer Mode	690		Newly added
Section 16 Serial Communication Interface (SCI, IrDA) (The H8S/2695 is not equipped with an IrDA function)	691		Title amended
16.2.7 Serial Status Register (SSR)	706	Bit 7—Transmit Data Register Empty (TDRE)	Note * added
	707	Bit 6—Receive Data Register Full (RDRF)	
	709	Bit 2—Transmit End (TEND)	



Section	Page	Item	Description
16.2.8 Bit Rate Register (BRR)	713	Table 16-3 BRR Settings for Various Bit Rates (Asynchronous Mode)	28 MHz bit rate added
	714	Table 16-4 BRR Settings for Various Bit Rates (Clocked Synchronous Mode)	
	716	Table 16-5 Maximum Bit Rate for Each Frequency (Asynchronous Mode)	
	717	Table 16-6 Maximum Bit Rate with External Clock Input (Asynchronous Mode)	
	718	Table 16-7 Maximum Bit Rate with External Clock Input (Clocked Synchronous Mode)	
16.2.10 IrDA Control Register (IrCR)	720		Note added
16.3.2 Operation in Asynchronous Mode	730	Figure 16-5 Sample Serial Transmission Flowchart	Note * added
16.3.3 Multiprocessor Communication Function	739	Figure 16-10 Sample Multiprocessor Serial Transmission Flowchart	
16.3.4 Operation in Clocked Synchronous Mode	747	Figure 16-16 Sample Serial Transmission Flowchart	
	750	Figure 16-18 Sample Serial Reception Flowchart	
	752	Figure 16-20 Sample Flowchart of Simultaneous Serial Transmit and Receive Operations	
16.4 SCI Interrupts	756		
	757	Table 16-13 SCI Interrupt Sources	Note *1 added
16.5 Usage Notes	761	Restrictions on Use of DMAC or DTC	Note * added
	762	Figure 16-25 Sample Flowchart for Mode Transition during Transmission	

Section	Page	Item	Description
17.1.1 Features	767	• Three interrupt sources	Note * added
17.2.2 Serial Status Register (SSR)	775		Note * added to Bit 2 table
17.3.5 Clock	785	Table 17-5 Examples of Bit Rate B (bit/s) for Various BRR Settings	28 MHz bit rate added
	786	Table 17-6 Examples of BRR Settings for Bit Rate B (bit/s)	
		Table 17-7 Maximum Bit Rate at Various Frequencies (Smart Card Interface Mode)	
17.3.6 Data Transfer Operations	793, 794	Data Transfer Operation by DMAC or DTC	Note * added
17.4 Usage Notes	797, 798	Retransfer Operations (Except Block Transfer Mode)	
Section 18 I <sup>2</sup> C Bus Interface [Option] (This function is not available in the H8S/2695)	799		Title amended
18.2.4 I <sup>2</sup> C Bus Mode Register (ICMR)	811	Bits 5 to 3—Serial Clock Select (CKS2 to CKS0)	Transfer rate $\phi = 28$ MHz portion added
	815	Bit 3—Acknowledge Bit Judgement Selection (ACKE)	Note * added
	816 to 818	Bit 1—I <sup>2</sup> C Bus Interface Interrupt Request Flag (IRIC)	
	820, 821	Bit 5—I <sup>2</sup> C Bus Interface Continuous Transmission/Reception Interrupt Request Flag (IRTR)	
18.3.2 Initial Setting	829		Newly added
18.3.3 Master Transmit Operation	829 to 832		Replaced
18.3.4 Master Receive Operation	833 to 837		
18.3.8 Operation Using the DTC	843		Note * added
		Table 18-5 Examples of Operation Using the DTC	

Section	Page	Item	Description
18.3.9 Noise Canceler	—	Figure 18-14 Flowchart for Master Transmit Mode (Example)	Deleted
		Figure 18-15 Flowchart for Master Receive Mode (Example)	
18.4 Usage Notes	850	Table 18-7 Permissible SCL Rise Time ( $t_{sr}$ ) Values	$\emptyset = 28$ MHz portion added to time indication [ns]
	851	Table 18-8 I <sup>2</sup> C Bus Timing (with Maximum Influence of $t_{sr}/t_{st}$ )	$\emptyset = 28$ MHz portion added to time indication [ns] and values amended
	854 to 857	<ul style="list-style-type: none"> <li>Notes on IRIC Flag Clearance when Using Wait Function</li> <li>Notes on ICDR Reads and ICCR Access in Slave Transmit Mode</li> <li>Notes on TRS Bit Setting in Slave Mode</li> <li>Notes on ICDR Reads in Transmit Mode and ICDR Writes in Receive Mode</li> <li>Notes on ACKE Bit and TRS Bit in Slave Mode</li> </ul>	Newly added
19.1.2 Block Diagram	860	Figure 19-1 Block Diagram of A/D Converter	Note * added
19.2.2 A/D Control/Status Register (ADCSR)	864	Bit 7—A/D End Flag (ADF)	
19.2.3 A/D Control Register (ADCR)	867	Bits 7 and 6—Timer Trigger Select 1 and 0 (TRGS1, TRGS0)	
19.5 Interrupts	876	Table 19-6 A/D Converter Interrupt Source	
Section 20 D/A Converter	883		Title amended
21.1 Overview	891 to 893		H8S/2633R added after H8S/2633 and H8S/2695 added after H8S/2631
21.2.1 System Control Register (SYSCR)	892		Note * added

Section	Page	Item	Description
21.4 Usage Notes	893	When Using the DTC	Note * added
22.1 Overview	895		Description amended
22.1.2 Register Configuration			BCRL amended to MDCR
22.3 Operation	898	Table 22-3 Operating Modes and ROM (Mask ROM Version)	Note * description amended
22.11 Flash Memory Programmer Mode	938	Table 22-13 Programmer Mode Pin Settings	Note * added
22.11.1 Socket Adapter Pin Correspondence Diagram	939	Figure 22-18 Socket Adapter Pin Correspondence Diagram	Some pin names of H8S/2633 amended Notes *1 and *2 added
Section 23A Clock Pulse Generator (H8S/2633, H8S/2632, H8S/2631, H8S/2633F)	959		Title amended
23A.2.1 System Clock Control Register (SCKCR)	960	Bit 7— $\emptyset$ Clock Output Disable (PSTOP)	Direct transition added to software standby mode and watch mode in description
Section 23B Clock Pulse Generator (H8S/2633R, H8S/2695)	971 to 981		Newly added
24.1 Overview	983		Note * added
	984	Table 24-1 LSI Internal States in Each Mode	Notes *4 and *5 added, Note *6 description amended
	985	Figure 24-1(a) Mode Transition Diagram (H8S/2633 Series, H8S/2633R)	H8S/2633R added
	986	Figure 24-1(b) Mode Transition Diagram (H8S/2695)	Newly added
	987	Table 24.2(a) Power-Down Mode Transition Conditions (H8S/2633 Series, H8S/2633R)	H8S/2633R added
		Table 24.2(b) Power-Down Mode Transition Conditions (H8S/2695)	Newly added
24.1.1 Register Configuration	988		Note * added
		Table 24-3 Power-Down Mode Registers	Note *2 added

Section	Page	Item	Description
24.2.1 Standby Control Register (SBYCR)	989	Bit 7—Software Standby (SSBY)	Note * added
	990	Bits 6 to 4—Standby Timer Select 2 to 0 (STS2 to STS0)	Note * added and Description amended (Setting Prohibited) added to Bits 6 to 4 table
		Bit 3—Output Port Enable (OPE)	Note * added
24.2.2 System Clock Control Register (SCKCR)	991, 992	Bit 7— $\emptyset$ Clock Output Disable (PSTOP), Bit 3—Frequency Multiplication Factor Switch Mode Select (STCS), Bits 2 to 0—System Clock Select (SCK2 to SCK0)	Note * added
24.2.3 Low-Power Control Register (LPWRCR)	992		H8S/2633R added to bit table for H8S/2633 Series H8S/2695 bit table and Note * added
	993, 994	Bit 7—Direct Transfer On Flag (DTON) and Bit 6—Low Speed ON Flag (LSON)	Note *, *2 added
24.2.4 Timer Control/Status Register (TCSR)	995, 996		Note *1 added
24.5.1 Module Stop Mode	999		Note * added
	1000	Table 24-4 MSTP Bits and Corresponding On-Chip Supporting Modules	Note *2 added
24.5.2 Usage Notes	1001		Description of Reading I/O Ports in Subactive Mode added
24.6.3 Setting Oscillation Stabilization Time after Clearing Software Standby Mode	1003	Table 24-5 Oscillation Stabilization Time Settings	Under Standby Time, 16 states changed to 16 states (setting prohibited) Note * deleted.

Section	Page	Item	Description
24.8 Watch Mode (This function is not available in the H8S/2695)	1006 to 1009		Description (This function is not available in the H8S/2695) added after title
24.11 Direct Transitions (This function not available in the H8S/2695)			
24.8.3 Notes	1007	(3) DMAC/DTC activation and sub-active mode/watch mode transition, (4) Interrupt sources and sub-active mode/watch mode transition	Newly added
24.10.3 Usage Notes	1009		
24.12 $\emptyset$ Clock Output Disabling Function			Note * added
25.2 DC Characteristics	1012	Table 25-2 DC Characteristics (1)	Conditions amended Output high voltage item amended Input leakage current test conditions amended
	1013		Three-state leakage current (off state) test conditions amended Current dissipation standby mode typ. value amended from 0.01 to 1.0
	1014		Reference power supply current test conditions amended
	1015 to 1017	Table 25-2 DC Characteristics (2)	Preliminary deleted Conditions amended Note *2 PVcc value amended Notes *7 and *8 added
	1015		Input leakage current test conditions amended
	1016		Three-state leakage current (off state) test conditions amended

<b>Section</b>	<b>Page</b>	<b>Item</b>	<b>Description</b>
25.2 DC Characteristics	1017	Table 25-2 DC Characteristics (2)	Analog power supply current test conditions amended Reference current test conditions amended
	1018	Table 25-3 Permissible Output Currents	Conditions amended and Notes *1 and *2 added
	1019	Table 25-4 Bus Drive Characteristics	Conditions amended
25.3.1 Clock Timing	1021	Table 25-5 Clock Timing	Condition B clock oscillator settling time at reset (crystal) and clock oscillator settling time in software standby (crystal) min. values in table amended Conditions A and B amended Notes *1 and *2 added
25.3.2 Control Signal Timing	1023	Table 25-6 Control Signal Timing	
25.3.3 Bus Timing	1025, 1026	Table 25-7 Bus Timing	
	1027	Figure 25-6 Basic Bus Timing (Two-State Access)	Figure amended
25.3.4 DMAC Timing	1034	Table 25-8 DMAC Timing	Conditions A and B amended Notes *1 and *2 added
25.3.5 Timing of On-Chip Supporting Modules	1038, 1039	Table 25-9 Timing of On-Chip Supporting Modules	
	1044	Table 25-10 I <sup>2</sup> C Bus Timing	Conditions amended
25.4 A/D Conversion Characteristics	1046	Table 25-11 A/D Conversion Characteristics	Conditions A and B amended Full-scale error condition A maximum value amended from $\pm 7.0$ to $\pm 7.5$
25.5 D/A Conversion Characteristics	1047	Table 25-12 D/A Conversion Characteristics	Conditions A and B amended
25.6 Flash Memory Characteristics	1048	Table 25-13 Flash Memory Characteristics	Conditions amended
Section 26 Electrical Characteristics (H8S/2633R)	1051 to 1086		Newly added
Section 27 Electrical Characteristics (H8S/2695)	1087 to 1106		

Section	Page	Item	Description
A.2 Instruction Codes	1137 to 1144	Table A-2 Instruction Codes	CLRMAC, LDMAC, MAC, SHAL, and STMAC instructions amended
B.1A Addresses (H8S/2633 Series, H8S/2633F, H8S/2633R)	1184		H8S/2633R added to Addresses
	1193		Note added
B.1B Addresses (H8S/2695)	1194 to 1200		Newly added
B.2 Functions	1215	SSR0—Serial Status Register 0 to SSR4—Serial Status Register 4	Bit table for SSR0 to SSR4 amended Note *3 added
	1217	SBYCR—Standby Control Register	Note * added to standby timer select 2 to 0 table
	1218	SYSCR—System Control Register	1 under SYSCR amended to I
	1222	PFCR—Pin Function Control Register	Note * added to BUZZ output enable table
	1223	LPWRCR—Low-Power Control Register	Note *1 added to bit table
	1258	TSR1—Timer Status Register 1 to TSR5—Timer Status Register 5	Note *2 added
	1260, 1265	IPRA to IPRO, BCRL—Bus Control Register L	Note * added
	1266 to 1268, 1276 to 1289	MCR, DRAMCR, RTCNT, RTCOR, DMAWER, DMATCR, DMACR0A, DMACR0B, DMACR1A, DMACR1B, DMABCR, ICCR0, ICCR1, ICSR0, ICSR1, ICDR0, ICDR1, SARX0, SARX1, ICMR0, ICMR1, SAR0, and SAR1	Descriptions added
	1284	RSTCSR—Reset Control/Status Register	TCNT amended to RSTCSR in Note
	1288		∅ = 28 MHz transfer rate for bits 5 to 3 and note * added
	1292	TCSR1—Timer Control/Status Register 1	Description added
Appendix C I/O Port Block Diagrams	1299		



<b>Section</b>	<b>Page</b>	<b>Item</b>	<b>Description</b>
C.6 Port A Block Diagram	1322	Figure C-6 (a) Port A Block Diagram (Pin PA0)	PAn amended to PA0
	1323	Figure C-6 (b) Port A Block Diagram (Pin PA1)	PAn amended to PA1
	1324	Figure C-6 (c) Port A Block Diagram (Pin PA2)	Figure replaced
	1325	Figure C-6 (d) Port A Block Diagram (Pin PA3)	PAn amended to PA3
C.7 Port B Block Diagram	1326	Figure C-7 Port B Block Diagram (Pins PB0 to PB7)	PB1 amended to PBn
C.8 Port C Block Diagram	1327	Figure C-8 (a) Port C Block Diagram (Pins PC0 to PC5)	WDDRA amended to WDDRC, and WDRA amended to WDRC
	1328	Figure C-8 (b) Port C Block Diagram (Pins PC6 and PC7)	Legend amended
C.9 Port D Block Diagram	1329	Figure C-9 Port D Block Diagram (Pins PD0 to PD7)	Legend n = 1 to 7 amended to n = 0 to 7
C.10 Port E Block Diagram	1330	Figure C-10 Port E Block Diagram (Pins PE0 to PE7)	
C.13 Port 1 Block Diagram to C.24 Port G Block Diagram	1343 to 1386		Newly added
D.1 Port States in Each Mode	1387		Description added
		Table D-1 I/O Port States in Each Processing State (H8S/2633, H8S/2632, H8S/2631, H8S/2633F, H8S/2633R)	H8S/2633R added
	1388	Table D-1 I/O Port States in Each Processing State (H8S/2633, H8S/2632, H8S/2631, H8S/2633F, H8S/2633R)	LCAS under software standby mode amended to LCAS
	1391 to 1394	Table D-2 I/O Port States in Each Processing State (H8S/2695)	Newly added
Appendix F Product Code Lineup	1396	Table F.1 H8S/2633 Series Product Code Lineup	FP-128 amended to FP-128B H8S/2633R and H8S/2695 portion added Note * deleted

<b>Section</b>	<b>Page</b>	<b>Item</b>	<b>Description</b>
Appendix G Package Dimensions	1397		Description amended
		Figure G-1 TFP-120 Package Dimensions	Figures amended
	1398	Figure G-2 FP-128B Package Dimensions	

# Comparison of H8S/2633, H8S/2632, H8S/2631, H8S/2633F-ZTAT, H8S/2633RF-ZTAT, and H8S/2695 Product Specifications

A comparative listing of the specifications of the H8S/2633, H8S/2632, H8S/2631, H8S/2633F-ZTAT, H8S/2633RF-ZTAT, and H8S/2695 is provided below.

## Comparison of H8S/2633, H8S/2632, H8S/2631, H8S/2633F-ZTAT, H8S/2633RF-ZTAT, and H8S/2695 Product Specifications

	H8S/2633 Series				H8S/2633R Series	H8S/2695
	H8S/2633F-ZTAT	H8S/2633	H8S/2632	H8S/2631	H8S/2633RF-ZTAT	
Model	HD64F2633F25 HD64F2633TE25 HD64F2633F16 HD64F2633TE16	HD6432633F25 HD6432633TE25 HD6432633F16 HD6432633TE16	HD6432632F25 HD6432632TE25 HD6432632F16 HD6432632TE16	HD6432631F25 HD6432631TE25 HD6432631F16 HD6432631TE16	HD64F2633RF28 HD64F2633RTE28	HD6432695F28
RAM	16 kB	16 kB	12 kB	8 kB	16 kB	8 kB
ROM	256 kB flash memory	256 kB mask ROM	192 kB mask ROM	128 kB mask ROM	256 kB flash memory	192 kB mask ROM
ROM, RAM memory map	H'000000 H'01FFFF H'02FFFF H'03FFFF  H'FFB000 H'FFC000 H'FFD000 H'FFEFBF  H'FFFFC0 H'FFFFFF	On-chip ROM (256 kbytes)	On-chip ROM (192 kbytes)	On-chip ROM (128 kbytes)	On-chip ROM (256 kbytes)	On-chip ROM (192 kbytes)
Input clock frequency range	2 to 25 MHz* (2 to 16 MHz for 16 MHz operation version)					
Operating frequency range	25 MHz operation version: 2 to 25 MHz 16 MHz operation version: 2 to 16 MHz				2 to 28 MHz*	
Operating voltage range	25 MHz operation version PV <sub>cc</sub> = 4.5 V to 5.5 V, V <sub>cc</sub> = PLLV <sub>cc</sub> = 3.0 V to 3.6 V, AV <sub>cc</sub> = 4.5 V to 5.5 V, Vref = 4.5 V to AV <sub>cc</sub> 16 MHz operation version (low-voltage version)				PV <sub>cc</sub> = 4.5 V to 5.5 V (Single power supply version lacking V <sub>cc</sub> and PLLV <sub>cc</sub> pins) AV <sub>cc</sub> = 4.5 V to 5.5 V	

	H8S/2633 Series				H8S/2633R Series	H8S/2695	
	H8S/2633F-ZTAT	H8S/2633	H8S/2632	H8S/2631	H8S/2633RF-ZTAT		
	$PV_{CC} = 3.0\text{ V to }5.5\text{ V}$ , $V_{CC} = PLLV_{CC} = 3.0\text{ V to }3.6\text{ V}$ [When using A/D or D/A] $AV_{CC} = 3.6\text{ V to }5.5\text{ V}$ , $V_{ref} = 3.6\text{ V to }AV_{CC}$ [When not using A/D or D/A] $AV_{CC} = 3.3\text{ V to }5.5\text{ V}$ , $V_{ref} = 3.3\text{ V to }AV_{CC}$				$V_{ref} = 4.5\text{ V to }AV_{CC}$		
Power supply pins	2 power supply configurations, $PV_{CC}$ (5 V power supply) and $V_{CC}$ (3 V power supply), $PLLV_{CC}$ is 3 V power supply				<ul style="list-style-type: none"> <li><math>PV_{CC}</math> (5 V power supply) single power supply configuration</li> <li>Do not connect the VCL pin to the power supply. Instead, connect it to a ground via a 0.1 <math>\mu\text{F}</math> power supply stabilizer capacitor (which should be mounted close to the pin).</li> <li>Do not connect the <math>V_{CC}</math> power supply to the VCL pin.</li> <li>Note that the VCL pin is located in the same position as the <math>V_{CC}</math> pin on the older H8S/2633 Series and H8S/2633F.</li> </ul> <ul style="list-style-type: none"> <li>There is no <math>PLLV_{CC}</math> power supply pin.</li> </ul>		
EXTAL input level	$V_{IH}: V_{CC} \times 0.8\text{ V to }V_{CC} + 0.3\text{ V}$ $V_{IL}: -0.3\text{ V to }V_{CC} \times 0.2\text{ V}$ ( $V_{CC} = 3.0\text{ V to }3.6\text{ V}$ )				$V_{IH}: PV_{CC} \times 0.8\text{ V to }PV_{CC} + 0.3\text{ V}$ $V_{IL}: -0.3\text{ V to }PV_{CC} \times 0.2\text{ V}$ ( $PV_{CC} = 4.5\text{ V to }5.5\text{ V}$ )		
Interrupt sources	External interrupts: NMLIRQ7 to IRQ0 Internal interrupts: 72 sources				External interrupts: NMLIRQ7 to IRQ0 Internal interrupts: 49 sources		
32 kHz oscillator	Yes (subactive mode, subsleep mode, and watch mode supported)				No (subactive mode, subsleep mode, and watch mode not supported)		
Method of fixing OSC pin when 32 kHz oscillator not used							No 32 kHz oscillator. The HD6432695 is the HD6432633 Series. The pins corresponding to OSC1 and OSC2 in the HD64F2633 are NC pins in the HD6432695.

	H8S/2633 Series				H8S/2633R Series	H8S/2695
	H8S/2633F-ZTAT	H8S/2633	H8S/2632	H8S/2631	H8S/2633RF-ZTAT	
Properties of multi-use pins (pins 34 and 35)	Output of pins 34 and 35 is normally NMOS push-pull output, but is NMOS open-drain output when the IIC bus drive function is selected.					No IIC function. Pins 34 and 35 output is CMOS output.
Recommended external PLL circuit	See section 23A, Clock Oscillator (H8S/2633, H8S/2632, H8S/2631, H8S/2633F).				See section 23B, Clock Oscillator (H8S/2633R, H8S/2695).	
PC break controller (PBC)	Yes					No
DRAM interface	Yes					No
DMA controller (DMAC)	Yes					No
Data transfer controller (DTC)	Yes					No
I/O ports	Functions of H8S/2633, H8S/2632, H8S/2631, H8S/2633F, and H8S/2633R are identical. See section 10A, I/O Ports, for details.					Some functions of the H8S/2633 Series have been eliminated. See section 10B, I/O Ports, for details.
Programmable pulse generator (PPG)	Yes					No
8-bit timer (TMR)	Yes					No
14-bit PWM timer	Yes					No
WDTI	Yes					No
IrDA	Yes					No
I <sup>2</sup> C bus interface (IIC)	Yes [option]				Yes	No
D/A converter	Yes					No

Note: \* The input clock frequency range is 2 to 25 MHz (2 to 16 MHz on 16 MHz operation version: H8S/2633 Series only).

For 25 MHz <  $\phi$  ≤ 28 MHz operation on the H8S/2633R and H8S/2695, make sure to use a PLL with a multiplying factor set to  $\times 2$  or  $\times 4$  ( $\phi$  = operating frequency).

## Notes on H8S/2695

### 1. Notes on P35 Pin Functions (SCK1, SCK4) in H8S/2695

The following restrictions apply to the functions of P35 (SCK1, SCK4) in the H8S/2695. The functions indicated by \*2 below cannot be used in the H8S/2695, and these combinations must not be set.

#### (1) P35 Pin Functions in H8S/2633 Series and H8S/2633R

ICE	0				1	
CKE1(SCI1) CKE1(SCI4)	0 0		0, 1, 1 1, 0, 1		0 0	
C/ $\bar{A}$ (SCI1) C/ $\bar{A}$ (SCI4)	0 0		1 1		— 0	
CKE0(SCI1) CKE0(SCI4)	0 0		0, 1, 1 1, 0, 1		— 0	
P35DDR	0	1	—	—	—	—
Pin function	P35 input pin	P35 output pin*1	SCK1/SCK4 output pin*1	SCK1/SCK4 output pin*1	SCK1/SCK4 input pin	SCL0 input/output pin
	$\overline{\text{IRQ5}}$ input					

#### (2) P35 Pin Functions in H8S/2695

CKE1(SCI1) CKE1(SCI4)	0 0		0*2 1*2		1*2 0*2		1 1	
C/ $\bar{A}$ (SCI1) C/ $\bar{A}$ (SCI4)	0 0		1 1		— —		— —	
CKE0(SCI1) CKE0(SCI4)	0 0		0, 1, 1 1, 0, 1		— —		— —	
P35DDR	0	1	—	—	—	—	0*3	
Pin function	P35 input pin	P35 output pin	SCK1/SCK4 output pin	SCK1/SCK4 output pin	—	—	SCK1/SCK4 input pin	
	$\overline{\text{IRQ5}}$ input							

Notes: \*1 The output type is normally NMOS push-pull output, but NMOS open-drain output when P35ODR = 1.

\*2 These combinations must not be set.

\*3 If SCK1 and SCK4 are used as input (clock input) pins on the H8S/2695, P35DDR must be cleared to 0.

### 2. Notes on H8S/2695 Development (Using H8S/2633 Emulator Chip)

The H8S/2695 is not equipped with an I2C bus function and output from pins 34 and 35 is CMOS output (unless P34ODR or P35ODR is set to 1, respectively). These pins are used for NMOS push-pull output on the H8S/2633 emulator chip, so the output characteristics of these pins are different than is the case with the H8S/2695. If it is necessary to use pins 34 and 35 for CMOS output, use an appropriate resistance to pull up pins 34 and 35 of the H8S/2633 emulator chip.

## Manual Reference Pages

	H8S/2633 Series				H8S/2633R Series	H8S/2695
	H8S/2633F-ZTAT	H8S/2633	H8S/2632	H8S/2631	H8S/2633RF-ZTAT	
RAM	See section 21, RAM					
ROM	See section 22, ROM					
Interrupt Controller (INT)	See section 5, Interrupt Controller					
PC Break Controller (PBC)	See section 6, PC Break Controller (PBC)					—
DRAM Interface	See section 7, Bus Controller					—
DMA Controller (DMAC)	See section 8, DMA Controller (DMAC)					—
Data Transfer Controller (DTC)	See section 9, Data Transfer Controller (DTC)					—
I/O Ports	See section 10A, I/O Ports (H8S/2633, H8S/2632, H8S/2631, H8S/2633R)					See section 10B, I/O Ports (H8S/2695)
16-Bit Timer Pulse Unit (TPU)	See section 11, 16-Bit Timer Pulse Unit (TPU)					
Programmable Pulse Generator (PPG)	See section 12, Programmable Pulse Generator (PPG)					—
8-Bit Timers (TMR)	See section 13, 8-Bit Timers (TMR)					—
14-Bit PWM D/A	See section 14, 14-Bit PWM D/A					—
WDT0	See section 15, Watchdog Timer					
WDT1	See section 15, Watchdog Timer					—
Serial Communication Interface (SCI)	See section 16, Serial Communication Interface (SCI, IrDA)					
IrDA	See section 16, Serial Communication Interface (SCI, IrDA)					—
Smart Card Interface	See section 17, Smart Card Interface					
I <sup>2</sup> C Bus Interface (IIC)	See section 18, I <sup>2</sup> C Bus Interface (IIC)					—
A/D Converter	See section 19, A/D Converter					
D/A Converter	See section 20, D/A Converter					—
32 kHz oscillator	See section 23A, Clock Pulse Generator (H8S/2633, H8S/2632, H8S/2631, H8S/2633F)				See section 23B, Clock Pulse Generator (H8S/2633R, H8S/2695)	—
Clock Pulse Generator	See section 23A, Clock Pulse Generator (H8S/2633, H8S/2632, H8S/2631, H8S/2633F)				See section 23B, Clock Pulse Generator (H8S/2633R, H8S/2695)	
EXTAL input level	See section 25, Electrical Characteristics (H8S/2633, H8S/2632, H8S/2631, H8S/2633F)				See section 26, Electrical Characteristics (H8S/2633R)	See section 27, Electrical Characteristics (H8S/2695)

	H8S/2633 Series				H8S/2633R Series	H8S/2695
	H8S/2633F-ZTAT	H8S/2633	H8S/2632	H8S/2631	H8S/2633RF-ZTAT	
Recommended external PLL circuit	See section 23A, Clock Pulse Generator (H8S/2633, H8S/2632, H8S/2631, H8S/2633F)				See section 23B, Clock Pulse Generator (H8S/2633R, H8S/2695)	
Interrupt processing vector table	See section 5, Interrupt Controller See table 5.4(a)				See section 5, Interrupt Controller See table 5.4(b)	



# Contents

Section 1	Overview .....	1
1.1	Overview.....	1
1.2	Internal Block Diagram .....	8
1.3	Pin Description .....	11
1.3.1	Pin Arrangement .....	11
1.3.2	Pin Functions in Each Operating Mode.....	16
1.3.3	Pin Functions.....	31
Section 2	CPU.....	49
2.1	Overview.....	49
2.1.1	Features .....	49
2.1.2	Differences between H8S/2600 CPU and H8S/2000 CPU .....	50
2.1.3	Differences from H8/300 CPU .....	51
2.1.4	Differences from H8/300H CPU .....	52
2.2	CPU Operating Modes .....	52
2.3	Address Space.....	57
2.4	Register Configuration .....	58
2.4.1	Overview .....	58
2.4.2	General Registers.....	59
2.4.3	Control Registers.....	60
2.4.4	Initial Register Values .....	62
2.5	Data Formats.....	63
2.5.1	General Register Data Formats .....	63
2.5.2	Memory Data Formats.....	65
2.6	Instruction Set.....	66
2.6.1	Overview .....	66
2.6.2	Instructions and Addressing Modes .....	67
2.6.3	Table of Instructions Classified by Function.....	69
2.6.4	Basic Instruction Formats.....	76
2.7	Addressing Modes and Effective Address Calculation .....	78
2.7.1	Addressing Mode.....	78
2.7.2	Effective Address Calculation.....	81
2.8	Processing States .....	85
2.8.1	Overview .....	85
2.8.2	Reset State .....	86
2.8.3	Exception-Handling State .....	87
2.8.4	Program Execution State.....	90
2.8.5	Bus-Released State .....	90
2.8.6	Power-Down State.....	90

2.9	Basic Timing.....	91
2.9.1	Overview .....	91
2.9.2	On-Chip Memory (ROM, RAM) .....	91
2.9.3	On-Chip Supporting Module Access Timing.....	93
2.9.4	External Address Space Access Timing.....	94
2.10	Usage Note .....	94
2.10.1	TAS Instruction .....	94
<b>Section 3 MCU Operating Modes .....</b>		<b>95</b>
3.1	Overview.....	95
3.1.1	Operating Mode Selection.....	95
3.1.2	Register Configuration .....	96
3.2	Register Descriptions.....	96
3.2.1	Mode Control Register (MDCR).....	96
3.2.2	System Control Register (SYSCR) .....	97
3.2.3	Pin Function Control Register (PFCR) .....	99
3.3	Operating Mode Descriptions.....	102
3.3.1	Mode 4.....	102
3.3.2	Mode 5.....	102
3.3.3	Mode 6.....	102
3.3.4	Mode 7.....	102
3.4	Pin Functions in Each Operating Mode.....	103
3.5	Address Map in Each Operating Mode.....	103
<b>Section 4 Exception Handling.....</b>		<b>109</b>
4.1	Overview.....	109
4.1.1	Exception Handling Types and Priority .....	109
4.1.2	Exception Handling Operation .....	110
4.1.3	Exception Vector Table.....	110
4.2	Reset .....	112
4.2.1	Overview .....	112
4.2.2	Types of Reset.....	112
4.2.3	Reset Sequence .....	113
4.2.4	Interrupts after Reset .....	115
4.2.5	State of On-Chip Supporting Modules after Reset Release .....	115
4.3	Traces .....	116
4.4	Interrupts.....	117
4.5	Trap Instruction .....	118
4.6	Stack Status after Exception Handling .....	119
4.7	Notes on Use of the Stack.....	120
<b>Section 5 Interrupt Controller .....</b>		<b>121</b>
5.1	Overview.....	121

5.1.1	Features .....	121
5.1.2	Block Diagram.....	122
5.1.3	Pin Configuration .....	123
5.1.4	Register Configuration .....	123
5.2	Register Descriptions.....	124
5.2.1	System Control Register (SYSCR) .....	124
5.2.2	Interrupt Priority Registers A to L, O (IPRA to IPRL, IPRO).....	125
5.2.3	IRQ Enable Register (IER) .....	126
5.2.4	IRQ Sense Control Registers H and L (ISCRH, ISCRL).....	127
5.2.5	IRQ Status Register (ISR).....	128
5.3	Interrupt Sources.....	129
5.3.1	External Interrupts.....	129
5.3.2	Internal Interrupts .....	130
5.3.3	Interrupt Exception Handling Vector Table .....	130
5.4	Interrupt Operation .....	139
5.4.1	Interrupt Control Modes and Interrupt Operation .....	139
5.4.2	Interrupt Control Mode 0.....	142
5.4.3	Interrupt Control Mode 2.....	144
5.4.4	Interrupt Exception Handling Sequence .....	146
5.4.5	Interrupt Response Times.....	147
5.5	Usage Notes .....	148
5.5.1	Contention between Interrupt Generation and Disabling .....	148
5.5.2	Instructions that Disable Interrupts .....	149
5.5.3	Times when Interrupts are Disabled .....	149
5.5.4	Interrupts during Execution of EEPMOV Instruction.....	150
5.6	DTC and DMAC Activation by Interrupt (DMAC and DTC functions are not available in the H8S/2695) .....	150
5.6.1	Overview .....	150
5.6.2	Block Diagram.....	150
5.6.3	Operation (DMAC and DTC functions are not available in the H8S/2695).....	151
<b>Section 6 PC Break Controller (PBC)</b> (This function is not available in the H8S/2695).....		153
6.1	Overview.....	153
6.1.1	Features .....	153
6.1.2	Block Diagram.....	154
6.1.3	Register Configuration .....	155
6.2	Register Descriptions.....	155
6.2.1	Break Address Register A (BARA) .....	155
6.2.2	Break Address Register B (BARB).....	156
6.2.3	Break Control Register A (BCRA) .....	156
6.2.4	Break Control Register B (BCRB).....	158
6.2.5	Module Stop Control Register C (MSTPCRC).....	158

6.3	Operation .....	159
6.3.1	PC Break Interrupt Due to Instruction Fetch.....	159
6.3.2	PC Break Interrupt Due to Data Access .....	159
6.3.3	Notes on PC Break Interrupt Handling .....	160
6.3.4	Operation in Transitions to Power-Down Modes .....	160
6.3.5	PC Break Operation in Continuous Data Transfer .....	161
6.3.6	When Instruction Execution is Delayed by One State .....	162
6.3.7	Additional Notes .....	163
<b>Section 7 Bus Controller.....</b>		<b>165</b>
7.1	Overview.....	165
7.1.1	Features .....	165
7.1.2	Block Diagram.....	167
7.1.3	Pin Configuration .....	168
7.1.4	Register Configuration .....	169
7.2	Register Descriptions.....	170
7.2.1	Bus Width Control Register (ABWCR).....	170
7.2.2	Access State Control Register (ASTCR).....	171
7.2.3	Wait Control Registers H and L (WCRH, WCRL).....	172
7.2.4	Bus Control Register H (BCRH).....	175
7.2.5	Bus Control Register L (BCRL).....	178
7.2.6	Pin Function Control Register (PFCR) .....	180
7.2.7	Memory Control Register (MCR) .....	183
7.2.8	DRAM Control Register (DRAMCR).....	185
7.2.9	Refresh Timer Counter (RTCNT) .....	187
7.2.10	Refresh Time Constant Register (RTCOR).....	187
7.3	Overview of Bus Control.....	188
7.3.1	Area Partitioning .....	188
7.3.2	Bus Specifications .....	189
7.3.3	Memory Interfaces.....	190
7.3.4	Interface Specifications for Each Area.....	191
7.3.5	Chip Select Signals.....	192
7.4	Basic Bus Interface.....	193
7.4.1	Overview .....	193
7.4.2	Data Size and Data Alignment .....	193
7.4.3	Valid Strokes .....	195
7.4.4	Basic Timing .....	196
7.4.5	Wait Control .....	204
7.5	DRAM Interface	
	(This function is not available in the H8S/2695).....	206
7.5.1	Overview .....	206
7.5.2	Setting up DRAM Space .....	206
7.5.3	Address Multiplexing .....	207

7.5.4	Data Bus .....	207
7.5.5	DRAM Interface Pins .....	208
7.5.6	Basic Timing .....	208
7.5.7	Precharge State Control.....	210
7.5.8	Wait Control .....	211
7.5.9	Byte Access Control .....	213
7.5.10	Burst Operation .....	215
7.5.11	Refresh Control .....	219
7.6	DMAC Single Address Mode and DRAM Interface (This function is not available in the H8S/2695).....	223
7.6.1	DDS=1 .....	223
7.6.2	DDS=0.....	224
7.7	Burst ROM Interface .....	225
7.7.1	Overview .....	225
7.7.2	Basic Timing .....	225
7.7.3	Wait Control .....	227
7.8	Idle Cycle.....	228
7.8.1	Operation.....	228
7.8.2	Pin States in Idle Cycle .....	232
7.9	Write Data Buffer Function .....	233
7.10	Bus Release.....	234
7.10.1	Overview .....	234
7.10.2	Operation.....	234
7.10.3	Pin States in External Bus Released State.....	235
7.10.4	Transition Timing.....	236
7.10.5	Notes.....	237
7.11	Bus Arbitration (DMAC and DTC functions are not available in the H8S/2695) .....	238
7.11.1	Overview .....	238
7.11.2	Operation.....	238
7.11.3	Bus Transfer Timing .....	239
7.12	Resets and the Bus Controller.....	239
Section 8	DMA Controller (DMAC) (This function is not available in the H8S/2695) .....	241
8.1	Overview.....	241
8.1.1	Features .....	241
8.1.2	Block Diagram.....	242
8.1.3	Overview of Functions .....	243
8.1.4	Pin Configuration .....	245
8.1.5	Register Configuration .....	246
8.2	Register Descriptions (1) (Short Address Mode) .....	247
8.2.1	Memory Address Registers (MAR).....	248

8.2.2	I/O Address Register (IOAR).....	249
8.2.3	Execute Transfer Count Register (ETCR).....	249
8.2.4	DMA Control Register (DMACR).....	250
8.2.5	DMA Band Control Register (DMABCR).....	254
8.3	Register Descriptions (2) (Full Address Mode) .....	259
8.3.1	Memory Address Register (MAR).....	259
8.3.2	I/O Address Register (IOAR).....	259
8.3.3	Execute Transfer Count Register (ETCR).....	260
8.3.4	DMA Control Register (DMACR).....	261
8.3.5	DMA Band Control Register (DMABCR).....	265
8.4	Register Descriptions (3) .....	270
8.4.1	DMA Write Enable Register (DMAWER).....	270
8.4.2	DMA Terminal Control Register (DMATCR).....	272
8.4.3	Module Stop Control Register (MSTPCR) .....	273
8.5	Operation .....	274
8.5.1	Transfer Modes .....	274
8.5.2	Sequential Mode.....	276
8.5.3	Idle Mode.....	279
8.5.4	Repeat Mode .....	282
8.5.5	Single Address Mode .....	286
8.5.6	Normal Mode.....	289
8.5.7	Block Transfer Mode.....	292
8.5.8	DMAC Activation Sources .....	298
8.5.9	Basic DMAC Bus Cycles .....	301
8.5.10	DMAC Bus Cycles (Dual Address Mode) .....	302
8.5.11	DMAC Bus Cycles (Single Address Mode) .....	310
8.5.12	Write Data Buffer Function.....	316
8.5.13	DMAC Multi-Channel Operation .....	317
8.5.14	Relation between External Bus Requests, Refresh Cycles, the DTC, and the DMAC .....	319
8.5.15	NMI Interrupts and DMAC.....	320
8.5.16	Forced Termination of DMAC Operation.....	321
8.5.17	Clearing Full Address Mode .....	322
8.6	Interrupts.....	323
8.7	Usage Notes .....	324
Section 9	Data Transfer Controller (DTC) (This function is not available in the H8S/2695) .....	329
9.1	Overview.....	329
9.1.1	Features .....	329
9.1.2	Block Diagram.....	330
9.1.3	Register Configuration .....	331
9.2	Register Descriptions.....	332

9.2.1	DTC Mode Register A (MRA).....	332
9.2.2	DTC Mode Register B (MRB).....	334
9.2.3	DTC Source Address Register (SAR).....	335
9.2.4	DTC Destination Address Register (DAR).....	335
9.2.5	DTC Transfer Count Register A (CRA).....	335
9.2.6	DTC Transfer Count Register B (CRB).....	336
9.2.7	DTC Enable Registers (DTCER).....	336
9.2.8	DTC Vector Register (DTVECR).....	337
9.2.9	Module Stop Control Register A (MSTPCRA).....	338
9.3	Operation.....	339
9.3.1	Overview.....	339
9.3.2	Activation Sources.....	341
9.3.3	DTC Vector Table.....	342
9.3.4	Location of Register Information in Address Space.....	346
9.3.5	Normal Mode.....	347
9.3.6	Repeat Mode.....	348
9.3.7	Block Transfer Mode.....	349
9.3.8	Chain Transfer.....	351
9.3.9	Operation Timing.....	352
9.3.10	Number of DTC Execution States.....	353
9.3.11	Procedures for Using DTC.....	355
9.3.12	Examples of Use of the DTC.....	356
9.4	Interrupts.....	359
9.5	Usage Notes.....	359
Section 10A I/O Ports (H8S/2633, H8S/2632, H8S/2631, H8S/2633R).....		361
10A.1	Overview.....	361
10A.2	Port 1.....	366
10A.2.1	Overview.....	366
10A.2.2	Register Configuration.....	367
10A.2.3	Pin Functions.....	369
10A.3	Port 3.....	381
10A.3.1	Overview.....	381
10A.3.2	Register Configuration.....	381
10A.3.3	Pin Functions.....	384
10A.4	Port 4.....	387
10A.4.1	Overview.....	387
10A.4.2	Register Configuration.....	388
10A.4.3	Pin Functions.....	388
10A.5	Port 7.....	389
10A.5.1	Overview.....	389
10A.5.2	Register Configuration.....	390
10A.5.3	Pin Functions.....	392

10A.6	Port 9 .....	395
	10A.6.1 Overview .....	395
	10A.6.2 Register Configuration .....	396
	10A.6.3 Pin Functions .....	396
10A.7	Port A .....	397
	10A.7.1 Overview .....	397
	10A.7.2 Register Configuration .....	398
	10A.7.3 Pin Functions .....	401
	10A.7.4 MOS Input Pull-Up Function .....	401
10A.8	Port B .....	403
	10A.8.1 Overview .....	403
	10A.8.2 Register Configuration .....	404
	10A.8.3 Pin Functions .....	407
	10A.8.4 MOS Input Pull-Up Function .....	408
10A.9	Port C .....	409
	10A.9.1 Overview .....	409
	10A.9.2 Register Configuration .....	410
	10A.9.3 Pin Functions for Each Mode .....	413
	10A.9.4 MOS Input Pull-Up Function .....	415
10A.10	Port D .....	416
	10A.10.1 Overview .....	416
	10A.10.2 Register Configuration .....	417
	10A.10.3 Pin Functions .....	419
	10A.10.4 MOS Input Pull-Up Function .....	420
10A.11	Port E .....	421
	10A.11.1 Overview .....	421
	10A.11.2 Register Configuration .....	422
	10A.11.3 Pin Functions .....	424
	10A.11.4 MOS Input Pull-Up Function .....	425
10A.12	Port F .....	426
	10A.12.1 Overview .....	426
	10A.12.2 Register Configuration .....	427
	10A.12.3 Pin Functions .....	429
10A.13	Port G .....	431
	10A.13.1 Overview .....	431
	10A.13.2 Register Configuration .....	432
	10A.13.3 Pin Functions .....	434
Section 10B I/O Ports (H8S/2695) .....		437
10B.1	Overview .....	437
10B.2	Port 1 .....	442
	10B.2.1 Overview .....	442
	10B.2.2 Register Configuration .....	443



	10B.2.3 Pin Functions .....	445
10B.3	Port 3 .....	457
	10B.3.1 Overview .....	457
	10B.3.2 Register Configuration .....	457
	10B.3.3 Pin Functions .....	460
10B.4	Port 4 .....	463
	10B.4.1 Overview .....	463
	10B.4.2 Register Configuration .....	464
	10B.4.3 Pin Functions .....	464
10B.5	Port 7 .....	465
	10B.5.1 Overview .....	465
	10B.5.2 Register Configuration .....	466
	10B.5.3 Pin Functions .....	468
10B.6	Port 9 .....	470
	10B.6.1 Overview .....	470
	10B.6.2 Register Configuration .....	471
	10B.6.3 Pin Functions .....	471
10B.7	Port A .....	472
	10B.7.1 Overview .....	472
	10B.7.2 Register Configuration .....	473
	10B.7.3 Pin Functions .....	476
	10B.7.4 MOS Input Pull-Up Function .....	477
10B.8	Port B .....	478
	10B.8.1 Overview .....	478
	10B.8.2 Register Configuration .....	479
	10B.8.3 Pin Functions .....	482
	10B.8.4 MOS Input Pull-Up Function .....	483
10B.9	Port C .....	484
	10B.9.1 Overview .....	484
	10B.9.2 Register Configuration .....	485
	10B.9.3 Pin Functions for Each Mode .....	488
	10B.9.4 MOS Input Pull-Up Function .....	490
10B.10	Port D .....	491
	10B.10.1 Overview .....	491
	10B.10.2 Register Configuration .....	492
	10B.10.3 Pin Functions .....	494
	10B.10.4 MOS Input Pull-Up Function .....	495
10B.11	Port E .....	496
	10B.11.1 Overview .....	496
	10B.11.2 Register Configuration .....	497
	10B.11.3 Pin Functions .....	499
	10B.11.4 MOS Input Pull-Up Function .....	500
10B.12	Port F .....	501

10B.12.1 Overview .....	501
10B.12.2 Register Configuration .....	502
10B.12.3 Pin Functions .....	504
10B.13 Port G.....	506
10B.13.1 Overview .....	506
10B.13.2 Register Configuration .....	507
10B.13.3 Pin Functions.....	509
Section 11 16-Bit Timer Pulse Unit (TPU).....	511
11.1 Overview.....	511
11.1.1 Features .....	511
11.1.2 Block Diagram.....	515
11.1.3 Pin Configuration .....	516
11.1.4 Register Configuration .....	518
11.2 Register Descriptions.....	520
11.2.1 Timer Control Register (TCR) .....	520
11.2.2 Timer Mode Register (TMDR) .....	525
11.2.3 Timer I/O Control Register (TIOR) .....	527
11.2.4 Timer Interrupt Enable Register (TIER) .....	540
11.2.5 Timer Status Register (TSR).....	543
11.2.6 Timer Counter (TCNT) .....	547
11.2.7 Timer General Register (TGR) .....	548
11.2.8 Timer Start Register (TSTR).....	549
11.2.9 Timer Synchro Register (TSYR).....	550
11.2.10 Module Stop Control Register A (MSTPCRA).....	551
11.3 Interface to Bus Master.....	552
11.3.1 16-Bit Registers.....	552
11.3.2 8-Bit Registers.....	552
11.4 Operation .....	554
11.4.1 Overview .....	554
11.4.2 Basic Functions .....	555
11.4.3 Synchronous Operation .....	561
11.4.4 Buffer Operation .....	563
11.4.5 Cascaded Operation.....	567
11.4.6 PWM Modes .....	569
11.4.7 Phase Counting Mode .....	574
11.5 Interrupts.....	581
11.5.1 Interrupt Sources and Priorities.....	581
11.5.2 DTC/DMAC Activation (This function is not available in the H8S/2695).....	583
11.5.3 A/D Converter Activation .....	583
11.6 Operation Timing .....	584
11.6.1 Input/Output Timing .....	584

11.6.2	Interrupt Signal Timing .....	588
11.7	Usage Notes .....	592
Section 12	Programmable Pulse Generator (PPG) (This function is not available in the H8S/2695) .....	603
12.1	Overview.....	603
12.1.1	Features .....	603
12.1.2	Block Diagram.....	604
12.1.3	Pin Configuration .....	605
12.1.4	Registers .....	606
12.2	Register Descriptions.....	607
12.2.1	Next Data Enable Registers H and L (NDERH, NDERL).....	607
12.2.2	Output Data Registers H and L (PODRH, PODRL).....	608
12.2.3	Next Data Registers H and L (NDRH, NDRL).....	609
12.2.4	Notes on NDR Access.....	609
12.2.5	PPG Output Control Register (PCR).....	611
12.2.6	PPG Output Mode Register (PMR).....	613
12.2.7	Port 1 Data Direction Register (P1DDR) .....	616
12.2.8	Module Stop Control Register A (MSTPCRA).....	616
12.3	Operation .....	617
12.3.1	Overview .....	617
12.3.2	Output Timing .....	618
12.3.3	Normal Pulse Output.....	619
12.3.4	Non-Overlapping Pulse Output.....	621
12.3.5	Inverted Pulse Output .....	624
12.3.6	Pulse Output Triggered by Input Capture .....	625
12.4	Usage Notes .....	626
Section 13	8-Bit Timers (TMR) (This function is not available in the H8S/2695) .....	629
13.1	Overview.....	629
13.1.1	Features .....	629
13.1.2	Block Diagram.....	630
13.1.3	Pin Configuration .....	631
13.1.4	Register Configuration .....	632
13.2	Register Descriptions.....	633
13.2.1	Timer Counters 0 to 3 (TCNT0 to TCNT3) .....	633
13.2.2	Time Constant Registers A0 to A3 (TCORA0 to TCORA3).....	633
13.2.3	Time Constant Registers B0 to B3 (TCORB0 to TCORB3).....	634
13.2.4	Timer Control Registers 0 to 3 (TCR0 to TCR3).....	634
13.2.5	Timer Control/Status Registers 0 to 3 (TCSR0 to TCSR3) .....	637
13.2.6	Module Stop Control Register A (MSTPCRA).....	640
13.3	Operation .....	641

13.3.1	TCNT Incrementation Timing.....	641
13.3.2	Compare Match Timing .....	642
13.3.3	Timing of External RESET on TCNT.....	644
13.3.4	Timing of Overflow Flag (OVF) Setting.....	644
13.3.5	Operation with Cascaded Connection .....	645
13.4	Interrupts.....	646
13.4.1	Interrupt Sources and DTC Activation (The H8S/2695 does not have a DTC function or an 8-bit timer).....	646
13.4.2	A/D Converter Activation .....	646
13.5	Sample Application .....	647
13.6	Usage Notes .....	648
13.6.1	Contention between TCNT Write and Clear.....	648
13.6.2	Contention between TCNT Write and Increment .....	649
13.6.3	Contention between TCOR Write and Compare Match .....	650
13.6.4	Contention between Compare Matches A and B.....	651
13.6.5	Switching of Internal Clocks and TCNT Operation.....	651
13.6.6	Interrupts and Module Stop Mode.....	653
Section 14	14-Bit PWM D/A (This function is not available in the H8S/2695) .....	655
14.1	Overview.....	655
14.1.1	Features .....	655
14.1.2	Block Diagram.....	656
14.1.3	Pin Configuration .....	657
14.1.4	Register Configuration .....	657
14.2	Register Descriptions.....	658
14.2.1	PWM D/A Counter (DACNT) .....	658
14.2.2	PWM D/A Data Registers A and B (DADRA and DADRB) .....	659
14.2.3	PWM D/A Control Register (DACR).....	660
14.2.4	Module Stop Control Register B (MSTPCRB).....	662
14.3	Bus Master Interface.....	663
14.4	Operation .....	666
Section 15	Watchdog Timer (WDT1 is not available in the H8S/2695) .....	671
15.1	Overview.....	671
15.1.1	Features .....	671
15.1.2	Block Diagram.....	672
15.1.3	Pin Configuration .....	674
15.1.4	Register Configuration .....	674
15.2	Register Descriptions.....	675
15.2.1	Timer Counter (TCNT) .....	675
15.2.2	Timer Control/Status Register (TCSR) .....	675

15.2.3	Reset Control/Status Register (RSTCSR) .....	680
15.2.4	Pin Function Control Register (PFCR) .....	681
15.2.5	Notes on Register Access .....	682
15.3	Operation .....	684
15.3.1	Watchdog Timer Operation.....	684
15.3.2	Interval Timer Operation.....	686
15.3.3	Timing of Setting Overflow Flag (OVF).....	686
15.3.4	Timing of Setting of Watchdog Timer Overflow Flag (WOVF) .....	687
15.4	Interrupts.....	688
15.5	Usage Notes .....	688
15.5.1	Contention between Timer Counter (TCNT) Write and Increment .....	688
15.5.2	Changing Value of PSS and CKS2 to CKS0.....	689
15.5.3	Switching between Watchdog Timer Mode and Interval Timer Mode.....	689
15.5.4	System Reset by $\overline{\text{WDTOVF}}$ Signal .....	689
15.5.5	Internal Reset in Watchdog Timer Mode .....	689
15.5.6	OVF Flag Clearing in Interval Timer Mode .....	690
Section 16	Serial Communication Interface (SCI, IrDA) (The H8S/2695 is not equipped with an IrDA function).....	691
16.1	Overview.....	691
16.1.1	Features .....	691
16.1.2	Block Diagram.....	693
16.1.3	Pin Configuration .....	694
16.1.4	Register Configuration .....	695
16.2	Register Descriptions.....	697
16.2.1	Receive Shift Register (RSR).....	697
16.2.2	Receive Data Register (RDR) .....	697
16.2.3	Transmit Shift Register (TSR).....	698
16.2.4	Transmit Data Register (TDR) .....	698
16.2.5	Serial Mode Register (SMR).....	699
16.2.6	Serial Control Register (SCR).....	702
16.2.7	Serial Status Register (SSR).....	706
16.2.8	Bit Rate Register (BRR).....	710
16.2.9	Smart Card Mode Register (SCMR) .....	719
16.2.10	IrDA Control Register (IrCR) .....	720
16.2.11	Module Stop Control Registers B and C (MSTPCRB, MSTPCRC).....	721
16.3	Operation .....	723
16.3.1	Overview .....	723
16.3.2	Operation in Asynchronous Mode.....	726
16.3.3	Multiprocessor Communication Function.....	737
16.3.4	Operation in Clocked Synchronous Mode .....	745
16.3.5	IrDA Operation .....	753
16.4	SCI Interrupts .....	756
16.5	Usage Notes .....	758

Section 17	Smart Card Interface.....	767
17.1	Overview.....	767
17.1.1	Features .....	767
17.1.2	Block Diagram.....	768
17.1.3	Pin Configuration .....	769
17.1.4	Register Configuration .....	770
17.2	Register Descriptions.....	772
17.2.1	Smart Card Mode Register (SCMR).....	772
17.2.2	Serial Status Register (SSR).....	774
17.2.3	Serial Mode Register (SMR).....	776
17.2.4	Serial Control Register (SCR).....	778
17.3	Operation .....	779
17.3.1	Overview .....	779
17.3.2	Pin Connections.....	779
17.3.3	Data Format.....	781
17.3.4	Register Settings.....	783
17.3.5	Clock .....	785
17.3.6	Data Transfer Operations .....	787
17.3.7	Operation in GSM Mode.....	794
17.3.8	Operation in Block Transfer Mode .....	795
17.4	Usage Notes .....	796
Section 18	I <sup>2</sup> C Bus Interface [Option].....	799
	(This function is not available in the H8S/2695)	
18.1	Overview.....	799
18.1.1	Features .....	799
18.1.2	Block Diagram .....	800
18.1.3	Input/Output Pins.....	802
18.1.4	Register Configuration .....	803
18.2	Register Descriptions.....	804
18.2.1	I <sup>2</sup> C Bus Data Register (ICDR).....	804
18.2.2	Slave Address Register (SAR) .....	807
18.2.3	Second Slave Address Register (SARX).....	808
18.2.4	I <sup>2</sup> C Bus Mode Register (ICMR) .....	809
18.2.5	I <sup>2</sup> C Bus Control Register (ICCR) .....	812
18.2.6	I <sup>2</sup> C Bus Status Register (ICSR).....	819
18.2.7	Serial Control Register X (SCRX) .....	824
18.2.8	DDC Switch Register (DDCSWR) .....	825
18.2.9	Module Stop Control Register B (MSTPCRB).....	826
18.3	Operation .....	827
18.3.1	I <sup>2</sup> C Bus Data Format.....	827
18.3.2	Initial Setting .....	829
18.3.3	Master Transmit Operation .....	829

18.3.4	Master Receive Operation .....	833
18.3.5	Slave Receive Operation .....	838
18.3.6	Slave Transmit Operation.....	840
18.3.7	IRIC Setting Timing and SCL Control .....	842
18.3.8	Operation Using the DTC .....	843
18.3.9	Noise Canceler.....	844
18.3.10	Sample Flowcharts .....	844
18.3.11	Initialization of Internal State .....	847
18.4	Usage Notes .....	848
<b>Section 19 A/D Converter .....</b>		<b>859</b>
19.1	Overview.....	859
19.1.1	Features .....	859
19.1.2	Block Diagram.....	860
19.1.3	Pin Configuration .....	861
19.1.4	Register Configuration .....	862
19.2	Register Descriptions.....	863
19.2.1	A/D Data Registers A to D (ADDRA to ADDRD).....	863
19.2.2	A/D Control/Status Register (ADCSR).....	864
19.2.3	A/D Control Register (ADCR).....	867
19.2.4	Module Stop Control Register A (MSTPCRA).....	868
19.3	Interface to Bus Master.....	869
19.4	Operation .....	870
19.4.1	Single Mode (SCAN = 0).....	870
19.4.2	Scan Mode (SCAN = 1) .....	872
19.4.3	Input Sampling and A/D Conversion Time.....	874
19.4.4	External Trigger Input Timing .....	875
19.5	Interrupts.....	876
19.6	Usage Notes .....	876
<b>Section 20 D/A Converter</b>		
<b>(This function is not available in the H8S/2695) .....</b>		<b>883</b>
20.1	Overview.....	883
20.1.1	Features .....	883
20.1.2	Block Diagram.....	883
20.1.3	Input and Output Pins .....	885
20.1.4	Register Configuration .....	885
20.2	Register Descriptions.....	886
20.2.1	D/A Data Registers 0 to 3 (DADR0 to DADR3) .....	886
20.2.2	D/A Control Register 01 and 23 (DACR01 and DACR23) .....	886
20.2.3	Module Stop Control Register A and C (MSTPCRA and MSTPCRC).....	888
20.3	Operation .....	890

Section 21	RAM .....	891
21.1	Overview.....	891
21.1.1	Block Diagram.....	891
21.1.2	Register Configuration .....	892
21.2	Register Descriptions.....	892
21.2.1	System Control Register (SYSCR) .....	892
21.3	Operation .....	893
21.4	Usage Notes .....	893
Section 22	ROM .....	895
22.1	Overview.....	895
22.1.1	Block Diagram.....	895
22.1.2	Register Configuration .....	895
22.2	Register Descriptions.....	896
22.2.1	Mode Control Register (MDCR).....	896
22.3	Operation .....	896
22.4	Flash Memory Overview .....	899
22.4.1	Features .....	899
22.4.2	Overview .....	900
22.4.3	Flash Memory Operating Modes.....	901
22.4.4	On-Board Programming Modes .....	902
22.4.5	Flash Memory Emulation in RAM.....	904
22.4.6	Differences between Boot Mode and User Program Mode.....	905
22.4.7	Block Configuration .....	906
22.4.8	Pin Configuration .....	906
22.4.9	Register Configuration .....	907
22.5	Register Descriptions.....	907
22.5.1	Flash Memory Control Register 1 (FLMCR1).....	907
22.5.2	Flash Memory Control Register 2 (FLMCR2).....	910
22.5.3	Erase Block Register 1 (EBR1).....	911
22.5.4	Erase Block Register 2 (EBR2).....	912
22.5.5	RAM Emulation Register (RAMER) .....	913
22.5.6	Flash Memory Power Control Register (FLPWCR).....	915
22.5.7	Serial Control Register X (SCRX) .....	915
22.6	On-Board Programming Modes .....	916
22.6.1	Boot Mode.....	917
22.6.2	User Program Mode .....	921
22.7	Programming/Erasing Flash Memory.....	923
22.7.1	Program Mode.....	924
22.7.2	Program-Verify Mode .....	925
22.7.3	Erase Mode.....	929
22.7.4	Erase-Verify Mode .....	929
22.8	Protection.....	931



22.8.1	Hardware Protection .....	931
22.8.2	Software Protection .....	932
22.8.3	Error Protection .....	933
22.9	Flash Memory Emulation in RAM.....	935
22.10	Interrupt Handling when Programming/Erasing Flash Memory .....	937
22.11	Flash Memory Programmer Mode .....	937
22.11.1	Socket Adapter Pin Correspondence Diagram .....	938
22.11.2	Programmer Mode Operation.....	940
22.11.3	Memory Read Mode.....	941
22.11.4	Auto-Program Mode .....	944
22.11.5	Auto-Erase Mode.....	946
22.11.6	Status Read Mode.....	948
22.11.7	Status Polling.....	949
22.11.8	Programmer Mode Transition Time .....	949
22.11.9	Notes on Memory Programming.....	950
22.12	Flash Memory and Power-Down States .....	951
22.12.1	Note on Power-Down States .....	951
22.13	Flash Memory Programming and Erasing Precautions .....	952
22.14	Note on Switching from F-ZTAT Version to Mask ROM Version .....	957
Section 23A	<b>Clock Pulse Generator</b> (H8S/2633, H8S/2632, H8S/2631, H8S/2633F) .....	959
23A.1	Overview .....	959
23A.1.1	Block Diagram.....	959
23A.1.2	Register Configuration .....	960
23A.2	Register Descriptions.....	960
23A.2.1	System Clock Control Register (SCKCR) .....	960
23A.2.2	Low-Power Control Register (LPWRCR).....	961
23A.3	Oscillator .....	962
23A.3.1	Connecting a Crystal Resonator .....	962
23A.3.2	External Clock Input .....	965
23A.4	PLL Circuit .....	967
23A.5	Medium-Speed Clock Divider.....	967
23A.6	Bus Master Clock Selection Circuit .....	967
23A.7	Subclock Oscillator .....	968
23A.8	Subclock Waveform Shaping Circuit.....	969
23A.9	Note on Crystal Resonator.....	969
Section 23B	<b>Clock Pulse Generator (H8S/2633R, H8S/2695)</b> .....	971
23B.1	Overview .....	971
23B.1.1	Block Diagram.....	971
23B.1.2	Register Configuration .....	972
23B.2	Register Descriptions.....	972

23B.2.1	System Clock Control Register (SCKCR) .....	972
23B.2.2	Low-Power Control Register (LPWRCR).....	973
23B.3	Oscillator .....	974
23B.3.1	Connecting a Crystal Resonator .....	974
23B.3.2	External Clock Input .....	977
23B.4	PLL Circuit.....	979
23B.5	Medium-Speed Clock Divider.....	979
23B.6	Bus Master Clock Selection Circuit .....	980
23B.7	Subclock Oscillator (This function is not available in the H8S/2695).....	980
23B.8	Subclock Waveform Shaping Circuit.....	981
23B.9	Note on Crystal Resonator.....	981
 Section 24 Power-Down Modes .....		 983
24.1	Overview.....	983
24.1.1	Register Configuration .....	988
24.2	Register Descriptions.....	989
24.2.1	Standby Control Register (SBYCR) .....	989
24.2.2	System Clock Control Register (SCKCR) .....	991
24.2.3	Low-Power Control Register (LPWRCR).....	992
24.2.4	Timer Control/Status Register (TCSR).....	995
24.2.5	Module Stop Control Register (MSTPCR) .....	996
24.3	Medium-Speed Mode .....	997
24.4	Sleep Mode.....	998
24.4.1	Sleep Mode.....	998
24.4.2	Exiting Sleep Mode.....	998
24.5	Module Stop Mode.....	999
24.5.1	Module Stop Mode.....	999
24.5.2	Usage Notes.....	1001
24.6	Software Standby Mode .....	1001
24.6.1	Software Standby Mode .....	1001
24.6.2	Exiting Software Standby Mode .....	1001
24.6.3	Setting Oscillation Stabilization Time after Clearing Software Standby Mode....	1002
24.6.4	Software Standby Mode Application Example .....	1003
24.6.5	Usage Notes.....	1004
24.7	Hardware Standby Mode.....	1005
24.7.1	Hardware Standby Mode.....	1005
24.7.2	Hardware Standby Mode Timing .....	1005
24.8	Watch Mode (This function is not available in the H8S/2695).....	1006
24.8.1	Watch Mode.....	1006
24.8.2	Exiting Watch Mode.....	1006
24.8.3	Notes .....	1007

24.9 Sub-Sleep Mode	
(This function is not available in the H8S/2695).....	1007
24.9.1 Sub-Sleep Mode.....	1007
24.9.2 Exiting Sub-Sleep Mode.....	1008
24.10 Sub-Active Mode	
(This function is not available in the H8S/2695).....	1008
24.10.1 Sub-Active Mode.....	1008
24.10.2 Exiting Sub-Active Mode.....	1008
24.10.3 Usage Notes.....	1009
24.11 Direct Transitions	
(This function is not available in the H8S/2695).....	1010
24.11.1 Overview of Direct Transitions.....	1010
24.12 $\emptyset$ Clock Output Disabling Function.....	1010
Section 25 Electrical Characteristics	
(H8S/2633, H8S/2632, H8S/2631, H8S/2633F).....	1011
25.1 Absolute Maximum Ratings.....	1011
25.2 DC Characteristics.....	1012
25.3 AC Characteristics.....	1020
25.3.1 Clock Timing.....	1021
25.3.2 Control Signal Timing.....	1023
25.3.3 Bus Timing.....	1025
25.3.4 DMAC Timing.....	1034
25.3.5 Timing of On-Chip Supporting Modules.....	1038
25.4 A/D Conversion Characteristics.....	1046
25.5 D/A Conversion Characteristics.....	1047
25.6 Flash Memory Characteristics.....	1048
25.7 Usage Note.....	1049
Section 26 Electrical Characteristics (H8S/2633R).....	1051
26.1 Absolute Maximum Ratings.....	1051
26.2 DC Characteristics.....	1052
26.3 AC Characteristics.....	1057
26.3.1 Clock Timing.....	1058
26.3.2 Control Signal Timing.....	1060
26.3.3 Bus Timing.....	1062
26.3.4 DMAC Timing.....	1071
26.3.5 Timing of On-Chip Supporting Modules.....	1075
26.4 A/D Conversion Characteristics.....	1082
26.5 D/A Conversion Characteristics.....	1083
26.6 Flash Memory Characteristics.....	1084
26.7 Usage Note.....	1085

Section 27	Electrical Characteristics (H8S/2695)	1087
27.1	Absolute Maximum Ratings	1087
27.2	DC Characteristics	1088
27.3	AC Characteristics	1091
27.3.1	Clock Timing	1092
27.3.2	Control Signal Timing	1094
27.3.3	Bus Timing	1096
27.3.4	Timing of On-Chip Supporting Modules	1103
27.4	A/D Conversion Characteristics	1106
27.5	Usage Note	1106
Appendix A	Instruction Set	1107
A.1	Instruction List	1107
A.2	Instruction Codes	1131
A.3	Operation Code Map	1146
A.4	Number of States Required for Instruction Execution	1150
A.5	Bus States During Instruction Execution	1164
A.6	Condition Code Modification	1178
Appendix B	Internal I/O Register	1184
B.1A	Addresses (H8S/2633 Series, H8S/2633F, H8S/2633R)	1184
B.1B	Addresses (H8S/2695)	1194
B.2	Functions	1201
Appendix C	I/O Port Block Diagrams	1299
C.1	Port 1 Block Diagram	1299
C.2	Port 3 Block Diagram	1305
C.3	Port 4 Block Diagram	1313
C.4	Port 7 Block Diagram	1314
C.5	Port 9 Block Diagram	1321
C.6	Port A Block Diagram	1322
C.7	Port B Block Diagram	1326
C.8	Port C Block Diagram	1327
C.9	Port D Block Diagram	1329
C.10	Port E Block Diagram	1330
C.11	Port F Block Diagram	1331
C.12	Port G Block Diagram	1339
C.13	Port 1 Block Diagram	1343
C.14	Port 3 Block Diagram	1349
C.15	Port 4 Block Diagram	1357
C.16	Port 7 Block Diagram	1358
C.17	Port 9 Block Diagram	1365
C.18	Port A Block Diagram	1366

C.19	Port B Block Diagram .....	1370
C.20	Port C Block Diagram .....	1371
C.21	Port D Block Diagram .....	1373
C.22	Port E Block Diagram.....	1374
C.23	Port F Block Diagram.....	1375
C.24	Port G Block Diagram .....	1383
Appendix D Pin States .....		1387
D.1	Port States in Each Mode .....	1387
Appendix E Timing of Transition to and Recovery from Hardware Standby Mode.....		1395
Appendix F Product Code Lineup .....		1396
Appendix G Package Dimensions.....		1397



# Section 1 Overview

## 1.1 Overview

The H8S/2633 Series is a series of microcomputers (MCUs: microcomputer units), built around the H8S/2600 CPU, employing Hitachi's proprietary architecture, and equipped with peripheral functions on-chip.

The H8S/2600 CPU has an internal 32-bit architecture, is provided with sixteen 16-bit general registers and a concise, optimized instruction set designed for high-speed operation, and can address a 16-Mbyte linear address space. The instruction set is upward-compatible with H8/300 and H8/300H CPU instructions at the object-code level, facilitating migration from the H8/300, H8/300L, or H8/300H Series.

On-chip peripheral functions required for system configuration include DMA controller (DMAC)\*<sup>2</sup>, data transfer controller (DTC)\*<sup>2</sup> bus masters, ROM and RAM memory, a 16-bit timer-pulse unit (TPU), programmable pulse generator (PPG)\*<sup>2</sup>, 8-bit timer\*<sup>2</sup>, 14-bit PWM timer (PWM)\*<sup>2</sup>, watchdog timer (WDT), serial communication interface (SCI, IrDA)\*<sup>2</sup>, A/D converter, D/A converter\*<sup>2</sup>, and I/O ports. It is also possible to incorporate an on-chip PC bus interface (IIC)\*<sup>2</sup> as an option.

On-chip ROM is available as 256-kbyte flash memory (F-ZTAT™ version)\*<sup>1</sup> or as 256-, 128-, or 64-kbyte mask ROM. ROM is connected to the CPU via a 16-bit data bus, enabling both byte and word data to be accessed in one state. Instruction fetching has been speeded up, and processing speed increased.

Four operating modes, modes 4 to 7, are provided, and there is a choice of single-chip mode or external expansion mode.

The features of the H8S/2633 Series are shown in table 1-1.

Notes: \*1 F-ZTAT™ is a trademark of Hitachi, Ltd.

\*2 This function is not available in the H8S/2695.

**Table 1-1 Overview**

<b>Item</b>	<b>Specification</b>
CPU	<ul style="list-style-type: none"> <li>• General-register machine <ul style="list-style-type: none"> <li>— Sixteen 16-bit general registers (also usable as sixteen 8-bit registers or eight 32-bit registers)</li> </ul> </li> <li>• High-speed operation suitable for realtime control <ul style="list-style-type: none"> <li>— Maximum clock rate: 25 MHz (H8S/2633 Series, H8S/2633F), 28 MHz (H8S/2633R, H8S/2695)</li> <li>— High-speed arithmetic operations <ul style="list-style-type: none"> <li>8/16/32-bit register-register add/subtract : 40 ns, 35 ns</li> <li>16 × 16-bit register-register multiply : 160 ns, 140 ns</li> <li>16 × 16 + 42-bit multiply and accumulate : 160 ns, 140 ns</li> <li>32 ÷ 16-bit register-register divide : 800 ns, 700 ns</li> </ul> </li> </ul> </li> <li>• Instruction set suitable for high-speed operation <ul style="list-style-type: none"> <li>— Sixty-nine basic instructions</li> <li>— 8/16/32-bit move/arithmetic and logic instructions</li> <li>— Unsigned/signed multiply and divide instructions</li> <li>— Multiply-and accumulate instruction</li> <li>— Powerful bit-manipulation instructions</li> </ul> </li> <li>• Two CPU operating modes <ul style="list-style-type: none"> <li>— Normal mode: 64-kbyte address space (cannot be used in the H8S/2633 Series)</li> <li>— Advanced mode: 16-Mbyte address space</li> </ul> </li> </ul>
Bus controller	<ul style="list-style-type: none"> <li>• Address space divided into 8 areas, with bus specifications settable independently for each area</li> <li>• Choice of 8-bit or 16-bit access space for each area</li> <li>• 2-state or 3-state access space can be designated for each area</li> <li>• Number of program wait states can be set for each area</li> <li>• Burst ROM directly connectable</li> <li>• Possible to connect* a maximum of 8 MB of DRAM (alternatively, it is also possible to use an interval timer)</li> <li>• External bus release function</li> </ul>
PC break controller	<ul style="list-style-type: none"> <li>• Supports debugging functions by means of PC break interrupts</li> <li>• Two break channels</li> </ul>
DMA controller (DMAC)*	<ul style="list-style-type: none"> <li>• Short address mode and full address mode selectable</li> <li>• Short address mode: 4 channels</li> <li>• Full address mode: 2 channels</li> <li>• Transfer possible in repeat mode/block transfer mode</li> <li>• Transfer possible in single address mode</li> <li>• Activation by internal interrupt possible</li> </ul>

Note: \* This function is not available in the H8S/2695.



Item	Specification
Data transfer controller (DTC)* <sup>1</sup>	<ul style="list-style-type: none"> <li>• Can be activated by internal interrupt or software</li> <li>• Multiple transfers or multiple types of transfer possible for one activation source</li> <li>• Transfer possible in repeat mode, block transfer mode, etc.</li> <li>• Request can be sent to CPU for interrupt that activated DTC</li> </ul>
16-bit timer-pulse unit (TPU)	<ul style="list-style-type: none"> <li>• 6-channel 16-bit timer on-chip</li> <li>• Pulse I/O processing capability for up to 16 pins<sup>1</sup></li> <li>• Automatic 2-phase encoder count capability</li> </ul>
Programmable pulse generator (PPG)	<ul style="list-style-type: none"> <li>• Maximum 16-bit pulse output possible with TPU as time base</li> <li>• Output trigger selectable in 4-bit groups</li> <li>• Non-overlap margin can be set</li> <li>• Direct output or inverse output setting possible</li> </ul>
8-bit timer* <sup>1</sup> 4 channels	<ul style="list-style-type: none"> <li>• 8-bit up counter (external event count possible)</li> <li>• Time constant register × 2</li> <li>• 2 channel connection possible</li> </ul>
Watchdog timer 2 channels* <sup>2</sup>	<ul style="list-style-type: none"> <li>• Watchdog timer or interval timer selectable</li> <li>• Operation using sub-clock supported (WDT1 only)</li> </ul>
14-bit PWM timer (PWM)* <sup>1</sup>	<ul style="list-style-type: none"> <li>• Maximum of 4 outputs</li> <li>• Resolution: 1/16384</li> <li>• Maximum carrier frequency: 390.6 kHz (operating at 25 MHz), 437.6 kHz (operating at 28 MHz)</li> </ul>
Serial communication interface (SCI) 5 channels (SCI0 to SCI4)	<ul style="list-style-type: none"> <li>• Asynchronous mode or synchronous mode selectable</li> <li>• Multiprocessor communication function</li> <li>• Smart card interface function</li> </ul>
IrDA-equipped SCI* <sup>1</sup> 1 channel (SCI0)	<ul style="list-style-type: none"> <li>• Supports IrDA standard version 1.0</li> <li>• Tx/D and Rx/D encoding/decoding in IrDA format</li> <li>• Start/stop synchronization mode or clock synchronization mode selectable</li> <li>• Multiprocessor communications function</li> <li>• Smart card interface function</li> </ul>

Notes: \*1 This function is not available in the H8S/2695.

\*2 The watchdog timer in the H8S/2695 has one channel only.

Item	Specification																		
A/D converter	<ul style="list-style-type: none"> <li>Resolution: 10 bits</li> <li>Input: 16 channels</li> <li>High-speed conversion: 10.72 <math>\mu</math>s minimum conversion time (at 25 MHz operation)</li> <li>Single or scan mode selectable</li> <li>Sample and hold circuit</li> <li>A/D conversion can be activated by external trigger or timer trigger</li> </ul>																		
D/A converter*	<ul style="list-style-type: none"> <li>Resolution: 8 bits</li> <li>Output: 4 channels</li> </ul>																		
I/O ports	<ul style="list-style-type: none"> <li>73 I/O pins, 16 input-only pins</li> </ul>																		
Memory	<ul style="list-style-type: none"> <li>PROM or mask ROM</li> <li>High-speed static RAM</li> </ul> <table border="1"> <thead> <tr> <th>Product Name</th> <th>ROM</th> <th>RAM</th> </tr> </thead> <tbody> <tr> <td>H8S/2633</td> <td>256 kbytes</td> <td>16 kbytes</td> </tr> <tr> <td>H8S/2632</td> <td>192 kbytes</td> <td>12 kbytes</td> </tr> <tr> <td>H8S/2631</td> <td>128 kbytes</td> <td>8 kbytes</td> </tr> <tr> <td>H8S/2633R</td> <td>256 kbytes</td> <td>16 kbytes</td> </tr> <tr> <td>H8S/2695</td> <td>192 kbytes</td> <td>8 kbytes</td> </tr> </tbody> </table>	Product Name	ROM	RAM	H8S/2633	256 kbytes	16 kbytes	H8S/2632	192 kbytes	12 kbytes	H8S/2631	128 kbytes	8 kbytes	H8S/2633R	256 kbytes	16 kbytes	H8S/2695	192 kbytes	8 kbytes
Product Name	ROM	RAM																	
H8S/2633	256 kbytes	16 kbytes																	
H8S/2632	192 kbytes	12 kbytes																	
H8S/2631	128 kbytes	8 kbytes																	
H8S/2633R	256 kbytes	16 kbytes																	
H8S/2695	192 kbytes	8 kbytes																	
Interrupt controller	<ul style="list-style-type: none"> <li>Nine external interrupt pins (NMI, <math>\overline{\text{IRQ0}}</math> to <math>\overline{\text{IRQ7}}</math>)</li> <li>72 internal interrupt sources (including options), 49 interrupt sources in the H8S/2695</li> <li>Eight priority levels settable</li> </ul>																		
Power-down state	<ul style="list-style-type: none"> <li>Medium-speed mode</li> <li>Sleep mode</li> <li>Module stop mode</li> <li>Software standby mode</li> <li>Hardware standby mode</li> <li>Sub-clock operation (sub-active mode, sub-sleep mode, watch mode)</li> </ul>																		

Note: \* This function is not available in the H8S/2695.

Item	Specification				
Operating modes	Four MCU operating modes				
	<b>CPU Operating Mode</b>	<b>Description</b>	<b>On-Chip ROM</b>	<b>External Data Bus</b>	
				<b>Initial Value</b>	<b>Maximum Value</b>
	4	Advanced On-chip ROM disabled expansion mode	Disabled	16 bits	16 bits
	5	On-chip ROM disabled expansion mode	Disabled	8 bits	16 bits
	6	On-chip ROM enabled expansion mode	Enabled	8 bits	16 bits
	7	Single-chip mode	Enabled	—	—
Clock pulse generator	H8S/2633, H8S/2632, H8S/2631 <ul style="list-style-type: none"> <li>On-chip PLL circuit (×1, ×2, ×4)</li> <li>Input clock frequency: 2 to 25 MHz</li> </ul> H8S/2633R, H8S/2695 <ul style="list-style-type: none"> <li>On-chip PLL circuit (×1, ×2, ×4) : 2 to 25 MHz (×2, ×4) : 25 to 28 MHz</li> <li>Input clock frequency: 2 to 25 MHz</li> </ul>				
Packages	<ul style="list-style-type: none"> <li>120-pin plastic TQFP (TFP-120)</li> <li>128-pin plastic QFP (FP-128B)</li> </ul>				
I <sup>2</sup> C bus interface (IIC)* 2 channels (optional)	<ul style="list-style-type: none"> <li>Conforms to I<sup>2</sup>C bus interface type advocated by Philips</li> <li>Single master mode/slave mode</li> <li>Possible to determine arbitration lost conditions</li> <li>Supports two slave addresses</li> </ul>				

Note: \* This function is not available in the H8S/2695.

Item	Specification		
Product lineup	H8S/2633 Series, H8S/2633F, H8S/2633R, H8S/2695 Operating Frequencies and Voltages		
	28 MHz Operation Version	25 MHz Operation Version	16 MHz Operation Version
Input clock frequency range	2 to 25 MHz	2 to 25 MHz	2 to 16 MHz
Operating frequency range	2 to 25 MHz (For 25 to 28 MHz operation, make sure to use a PLL with a multiplying factor set to $\times 2$ or $\times 4$ .)	2 to 25 MHz	2 to 16 MHz
Operating voltage range	$PV_{CC} = 4.5$ to $5.5$ V (This is a single power supply and has no $V_{CC}$ pin. Refer to ~ for details.) $AV_{CC} = 4.5$ to $5.5$ V $V_{ref} = 4.5$ to $AV_{CC}$	$PV_{CC} = 4.5$ to $5.5$ V $V_{CC} = 3.0$ to $3.6$ V $AV_{CC} = 4.5$ to $5.5$ V $V_{ref} = 4.5$ to $AV_{CC}$	$PV_{CC} = 3.0$ to $5.5$ V $V_{CC} = 3.0$ to $3.6$ V [When using A/D or D/A] <sup>*2</sup> $AV_{CC} = 3.6$ to $5.5$ V $V_{ref} = 3.6$ V to $AV_{CC}$ [When not using A/D or D/A] <sup>*2</sup> $AV_{CC} = 3.3$ to $5.5$ V $V_{ref} = 3.3$ V to $AV_{CC}$
Flash version Model (ROM/RAM)	HD64F2633RF28 (256 kbytes/16 kbytes) HD64F2633RTE28 (256 kbytes/16 kbytes)	HD64F2633F25 (256 kbytes/16 kbytes) HD64F2633TE25 (256 kbytes/16 kbytes)	HD64F2633F16 (256 kbytes/16 kbytes) HD64F2633TE16 (256 kbytes/16 kbytes)
Mask version Model (ROM/RAM)	HD6432695F28 <sup>*1</sup> (192 kbytes/8 kbytes)	HD6432633F25 (256 kbytes/16 kbytes) HD6432633TE25 (256 kbytes/16 kbytes) HD6432632F25 (192 kbytes/12 kbytes) HD6432632TE25 (192 kbytes/12 kbytes) HD6432631F25 (128 kbytes/8 kbytes) HD6432631TE25 (128 kbytes/8 kbytes)	HD6432633F16 (256 kbytes/16 kbytes) HD6432633TE16 (256 kbytes/16 kbytes) HD6432632F16 (192 kbytes/12 kbytes) HD6432632TE16 (192 kbytes/12 kbytes) HD6432631F16 (128 kbytes/8 kbytes) HD6432631TE16 (128 kbytes/8 kbytes)
Notes: *1 The module configuration of the HD6432695 differs from that of the HD6432633 Series, HD64F2633, and HD64F2633R. (For information on the module configuration refer to comparison of H8S/2633, H8S/2632, H8S/2631, H8S/2633F-ZTAT, H8S/2633RF-ZTAT, and H8S/2695 Product Specifications.			
*2 In the case of the 16 MHz operation version, the operating power supply ranges differ depending on whether A/D or D/A conversion is used.			

Item	Specification																																								
Product lineup	Models and Corresponding Packages																																								
	<table border="1"> <thead> <tr> <th data-bbox="478 257 750 291">Model Name</th> <th data-bbox="750 257 1332 291">Package</th> </tr> </thead> <tbody> <tr> <td data-bbox="478 291 750 324">HD64F2633F25</td> <td data-bbox="750 291 1332 324">FP-128B</td> </tr> <tr> <td data-bbox="478 324 750 358">HD64F2633F16</td> <td></td> </tr> <tr> <td data-bbox="478 358 750 392">HD6432633F25</td> <td></td> </tr> <tr> <td data-bbox="478 392 750 425">HD6432633F16</td> <td></td> </tr> <tr> <td data-bbox="478 425 750 459">HD6432632F25</td> <td></td> </tr> <tr> <td data-bbox="478 459 750 492">HD6432632F16</td> <td></td> </tr> <tr> <td data-bbox="478 492 750 526">HD6432631F25</td> <td></td> </tr> <tr> <td data-bbox="478 526 750 560">HD6432631F16</td> <td></td> </tr> <tr> <td data-bbox="478 560 750 593">HD64F2633RF28</td> <td></td> </tr> <tr> <td data-bbox="478 593 750 627">HD6432695F28</td> <td></td> </tr> <tr> <td data-bbox="478 627 750 660">HD64F2633TE25</td> <td data-bbox="750 627 1332 660">TFP-120</td> </tr> <tr> <td data-bbox="478 660 750 694">HD64F2633TE16</td> <td></td> </tr> <tr> <td data-bbox="478 694 750 728">HD6432633TE25</td> <td></td> </tr> <tr> <td data-bbox="478 728 750 761">HD6432633TE16</td> <td></td> </tr> <tr> <td data-bbox="478 761 750 795">HD6432632TE25</td> <td></td> </tr> <tr> <td data-bbox="478 795 750 828">HD6432632TE16</td> <td></td> </tr> <tr> <td data-bbox="478 828 750 862">HD6432631TE25</td> <td></td> </tr> <tr> <td data-bbox="478 862 750 896">HD6432631TE16</td> <td></td> </tr> <tr> <td data-bbox="478 896 750 929">HD64F2633RTE28</td> <td></td> </tr> </tbody> </table>	Model Name	Package	HD64F2633F25	FP-128B	HD64F2633F16		HD6432633F25		HD6432633F16		HD6432632F25		HD6432632F16		HD6432631F25		HD6432631F16		HD64F2633RF28		HD6432695F28		HD64F2633TE25	TFP-120	HD64F2633TE16		HD6432633TE25		HD6432633TE16		HD6432632TE25		HD6432632TE16		HD6432631TE25		HD6432631TE16		HD64F2633RTE28	
Model Name	Package																																								
HD64F2633F25	FP-128B																																								
HD64F2633F16																																									
HD6432633F25																																									
HD6432633F16																																									
HD6432632F25																																									
HD6432632F16																																									
HD6432631F25																																									
HD6432631F16																																									
HD64F2633RF28																																									
HD6432695F28																																									
HD64F2633TE25	TFP-120																																								
HD64F2633TE16																																									
HD6432633TE25																																									
HD6432633TE16																																									
HD6432632TE25																																									
HD6432632TE16																																									
HD6432631TE25																																									
HD6432631TE16																																									
HD64F2633RTE28																																									

## 1.2 Internal Block Diagram

Figure 1-1 (a) shows an internal block diagram of the H8S/2633, H8S/2632, H8S/2631, and H8S/2633F. Figure 1-1 (b) shows the internal block diagram of the H8S/2633R. Figure 1-1 (c) shows the internal block diagram of the H8S/2695.

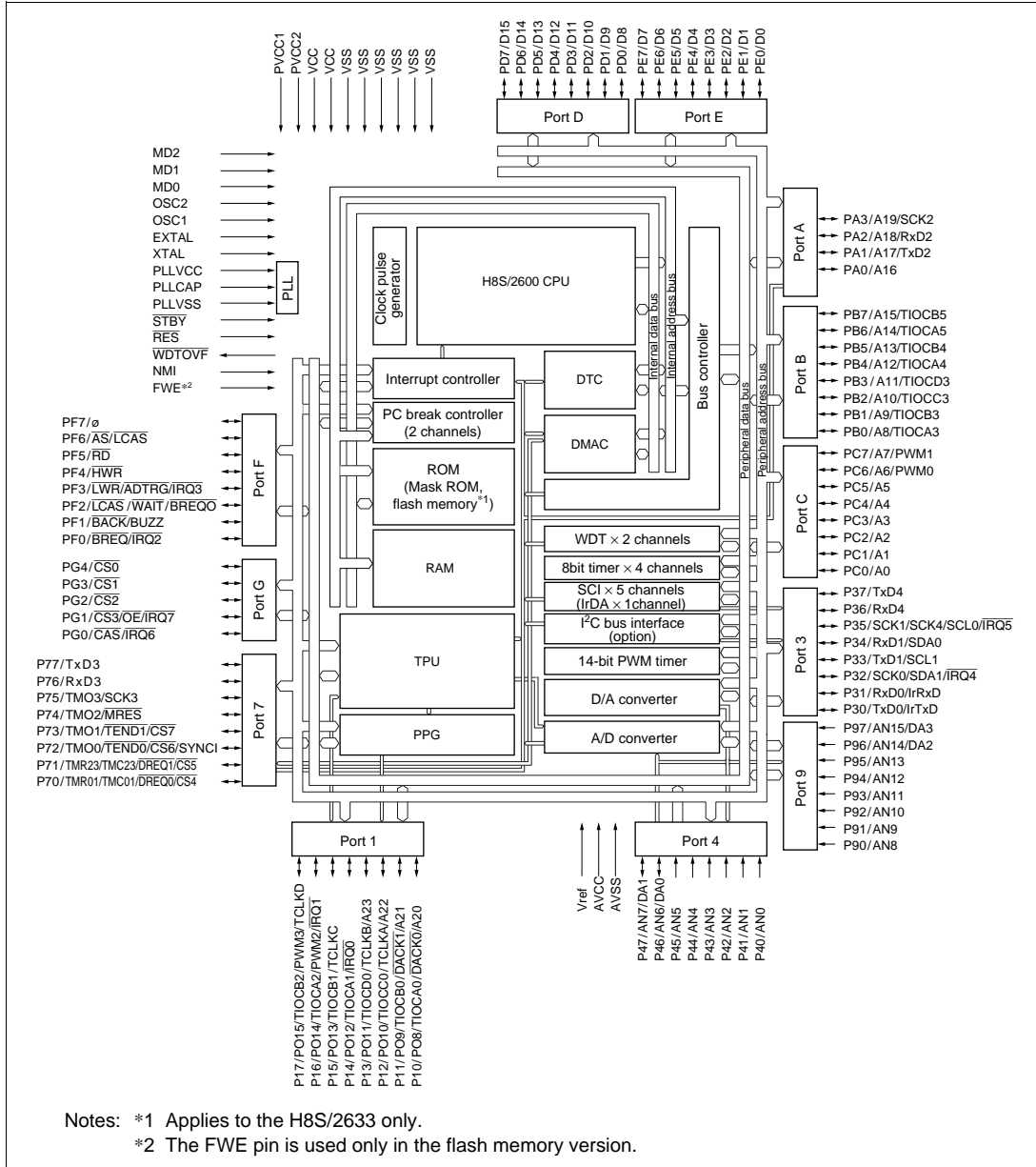


Figure 1-1 (a) H8S/2633F, H8S/2633, H8S/2632, H8S/2631 Internal Block Diagram

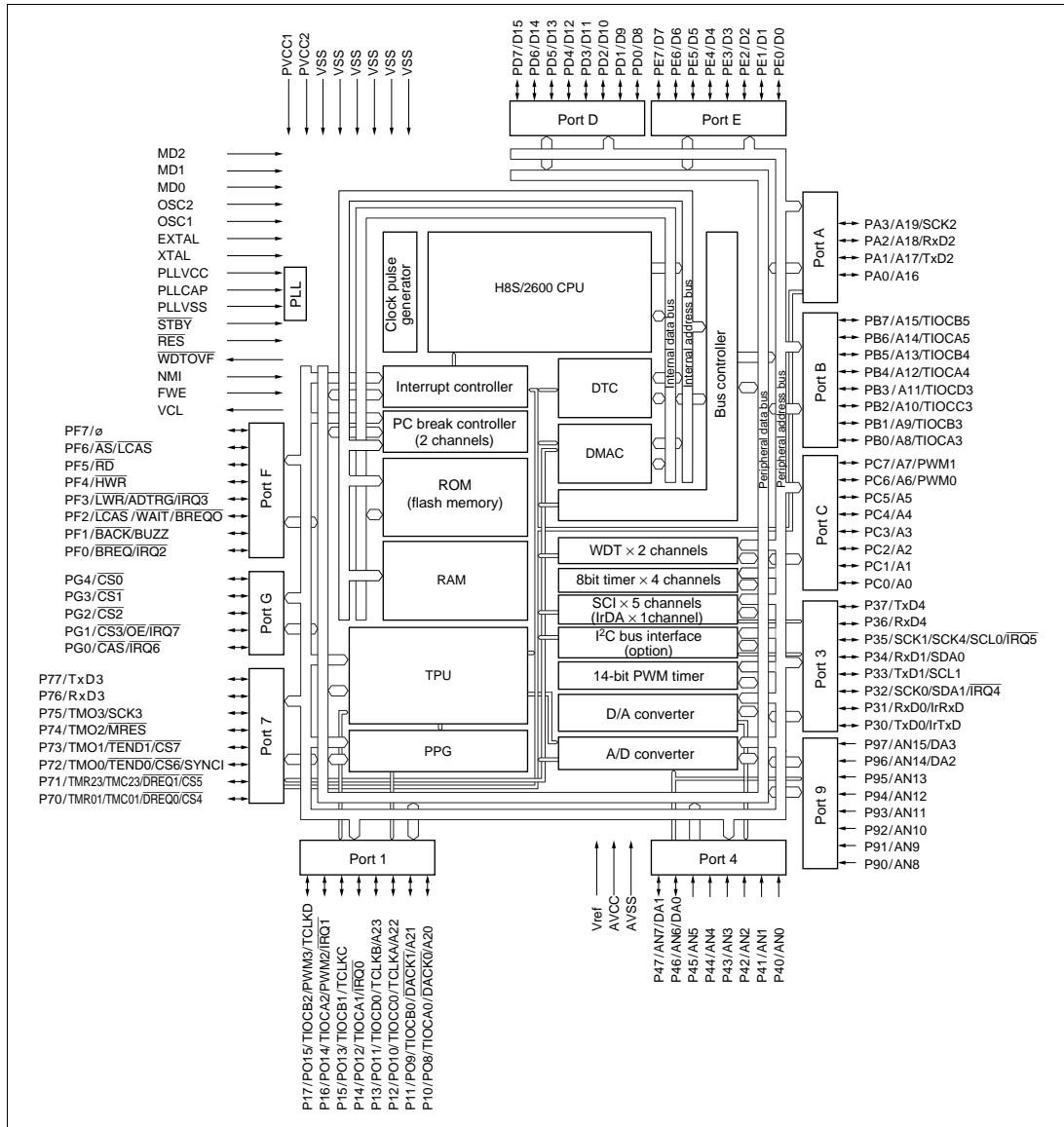


Figure 1-1 (b) H8S/2633R Internal Block Diagram

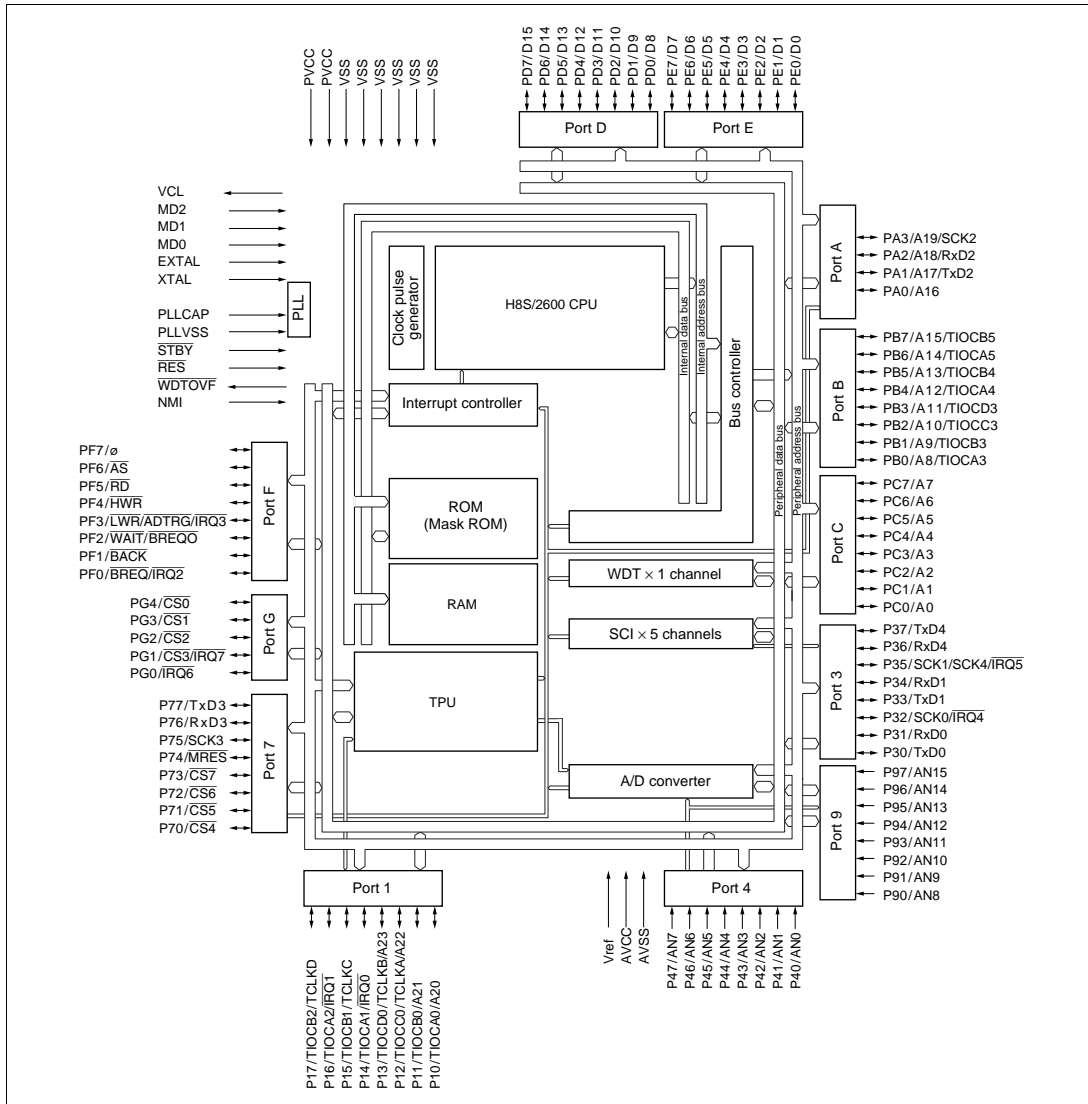


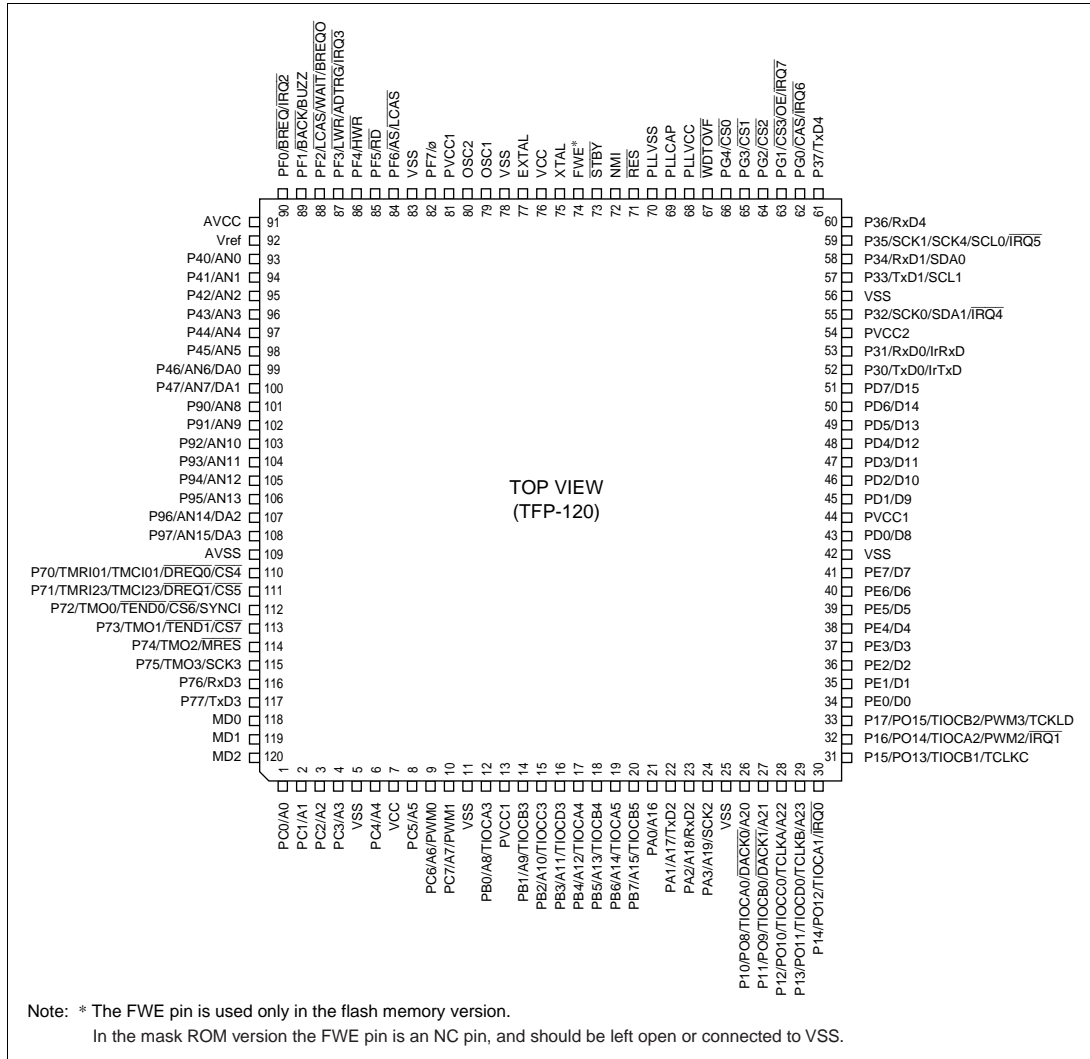
Figure 1-1 (c) H8S/2695 Internal Block Diagram



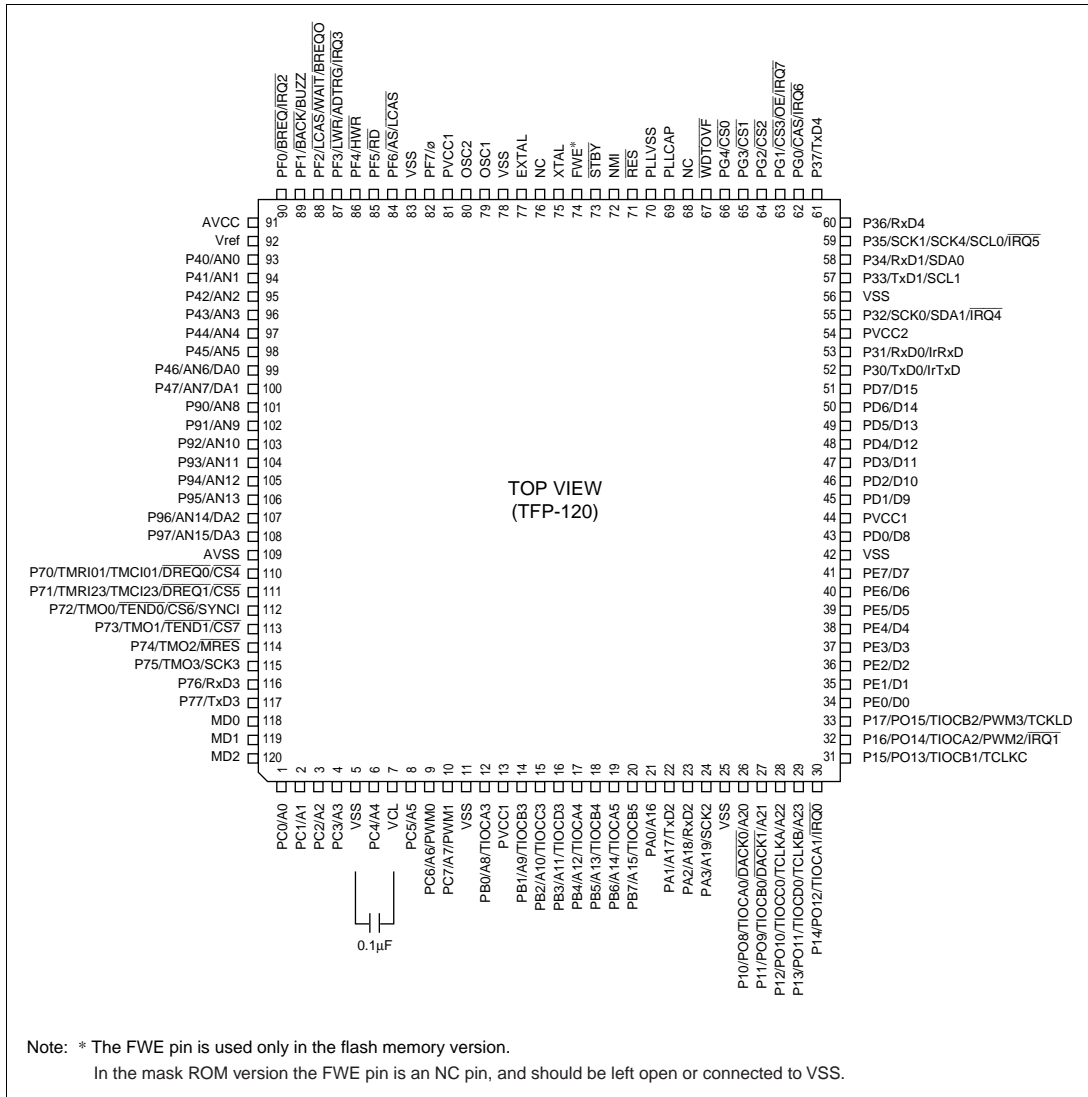
## 1.3 Pin Description

### 1.3.1 Pin Arrangement

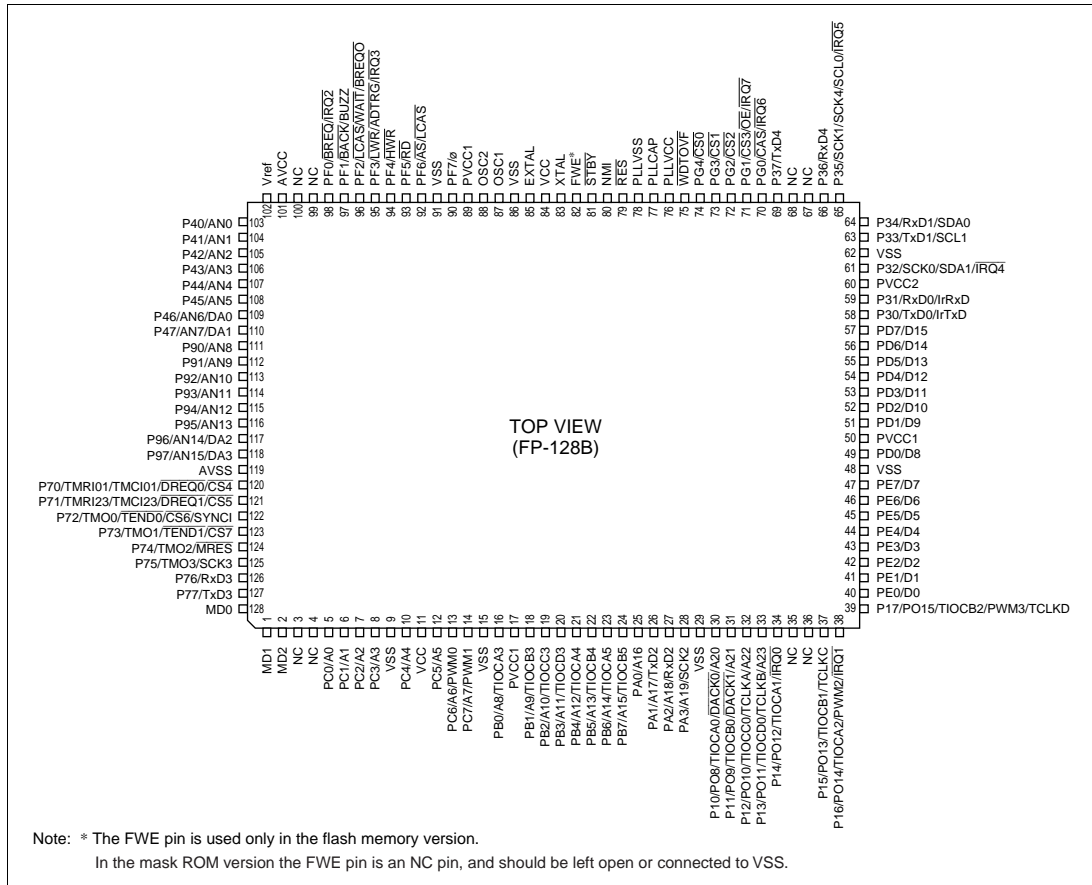
Figures 1-2 (a) and 1.3 (a) show the pin arrangement of the H8S/2633, H8S/2632, H8S/2631, and H8S/2633F. Figures 1-2 (b) and 1.3 (b) show the pin arrangement of the H8S/2633R. Figures 1-3 (c) shows the pin arrangement of the H8S/2695.



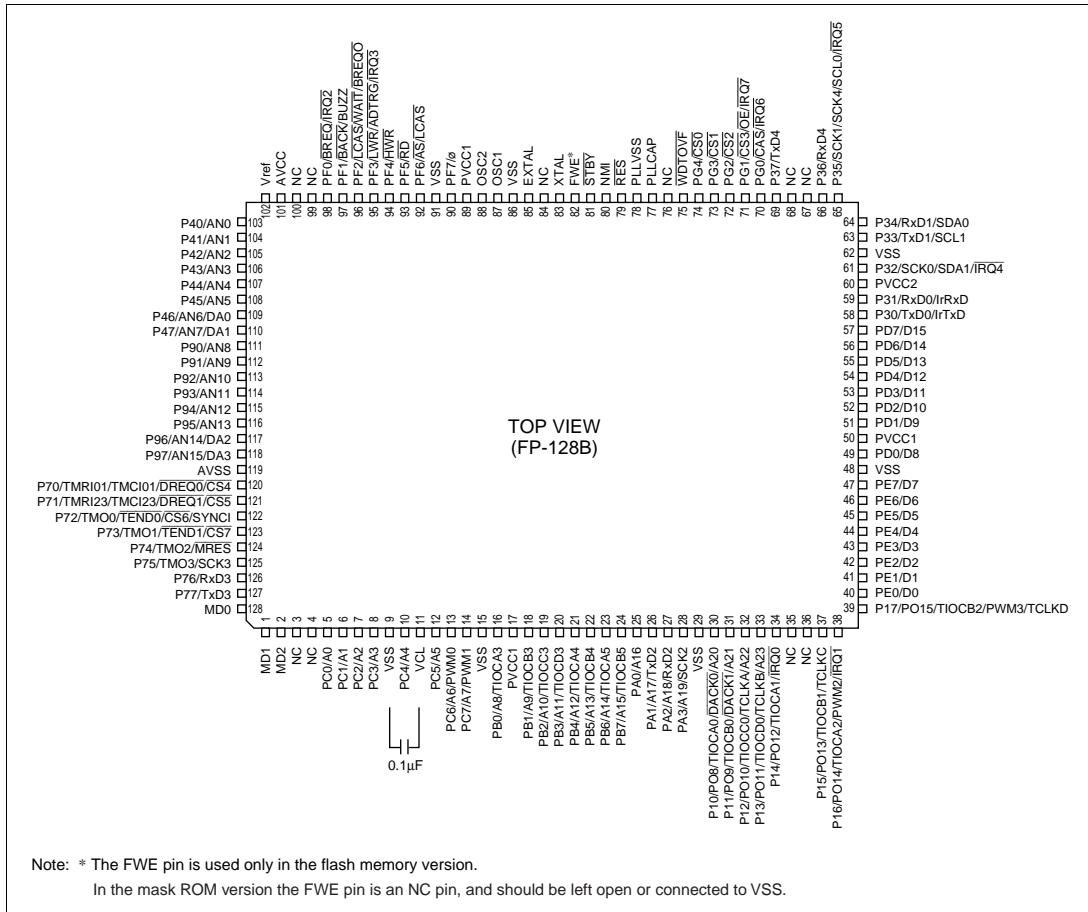
**Figure 1-2 (a) H8S/2633, H8S/2632, H8S/2631, H8S/2633F Pin Arrangement  
(TFP-120: Top View)**



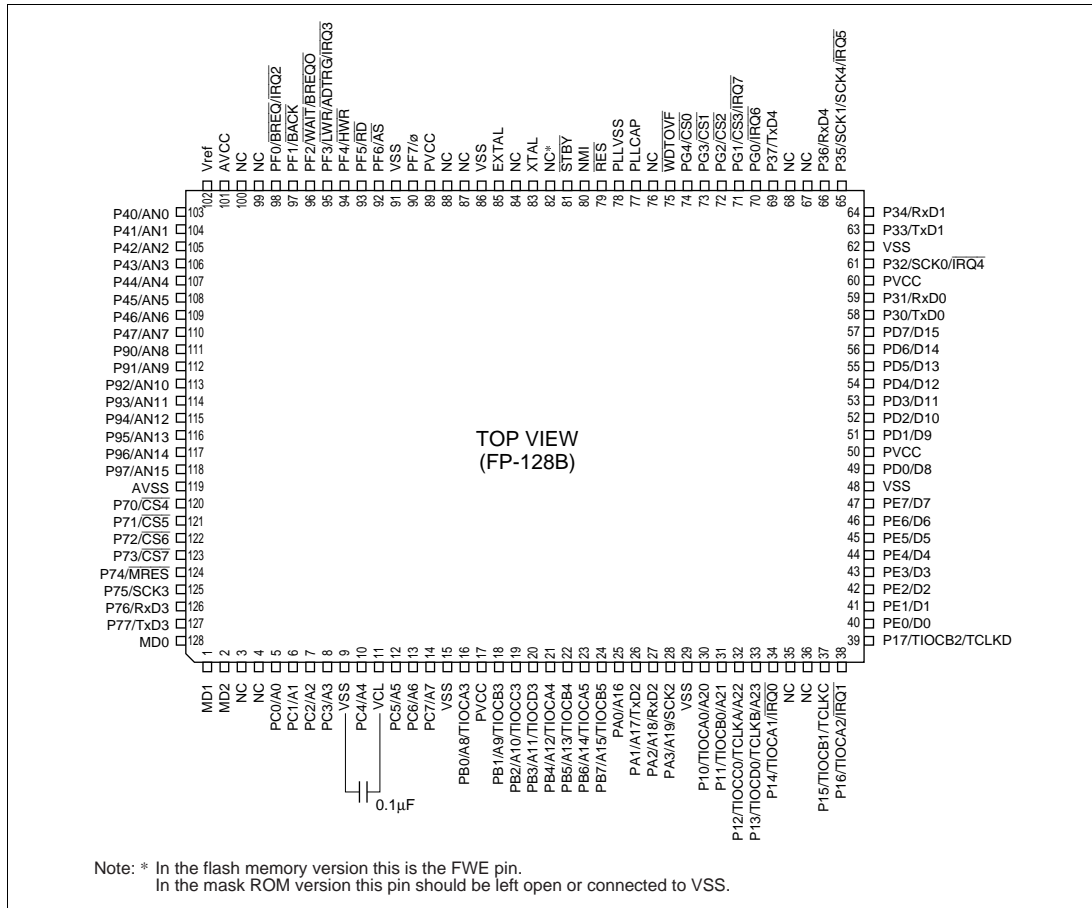
**Figure 1-2 (b) H8S/2633R Pin Arrangement (TFP-120: Top View)**



**Figure 1-3 (a) H8S/2633, H8S/2632, H8S/2631, H8S/2633F Pin Arrangement (FP-128B: Top View)**



**Figure 1-3 (b) H8S/2633R Pin Arrangement (FP-128B: Top View)**



**Figure 1-3 (c) H8S/2695 Pin Arrangement (FP-128B: Top View)**

### 1.3.2 Pin Functions in Each Operating Mode

Table 1-2 (a) shows the pin functions of the H8S/2633, H8S/2632, H8S/2631, and H8S/2633F in each of the operating modes. Table 1-2 (b) shows the pin functions of the H8S/2633R in each of the operating modes. Table 1-2 (c) shows the pin functions of the H8S/2695 in each of the operating modes.

**Table 1-2 (a) Pin Functions in Each Operating Mode (H8S/2633, H8S/2632, H8S/2631, H8S/2633F)**

Pin No.		Pin Name			
TFP-120	FP-128B	Mode 4	Mode 5	Mode 6	Mode 7
1	5	A0	A0	PC0/A0	PC0
2	6	A1	A1	PC1/A1	PC1
3	7	A2	A2	PC2/A2	PC2
4	8	A3	A3	PC3/A3	PC3
5	9	VSS	VSS	VSS	VSS
6	10	A4	A4	PC4/A4	PC4
7	11	VCC	VCC	VCC	VCC
8	12	A5	A5	PC5/A5	PC5
9	13	A6	A6	PC6/A6/PWM0	PC6/PWM0
10	14	A7	A7	PC7/A7/PWM1	PC7/PWM1
11	15	VSS	VSS	VSS	VSS
12	16	A8	A8	PB0/A8/TIOCA3	PB0/TIOCA3
13	17	PVCC1	PVCC1	PVCC1	PVCC1
14	18	A9	A9	PB1/A9/TIOCB3	PB1/TIOCB3
15	19	A10	A10	PB2/A10/TIOCC3	PB2/TIOCC3
16	20	A11	A11	PB3/A11/TIOCD3	PB3/TIOCD3
17	21	A12	A12	PB4/A12/TIOCA4	PB4/TIOCA4
18	22	A13	A13	PB5/A13/TIOCB4	PB5/TIOCB4
19	23	A14	A14	PB6/A14/TIOCA5	PB6/TIOCA5
20	24	A15	A15	PB7/A15/TIOCB5	PB7/TIOCB5
21	25	A16	A16	PA0/A16	PA0
22	26	A17	A17	PA1/A17/TxD2	PA1/TxD2
23	27	A18	A18	PA2/A18/RxD2	PA2/RxD2
24	28	A19	A19	PA3/A19/SCK2	PA3/SCK2
25	29	VSS	VSS	VSS	VSS

Pin No.		Pin Name			
TFP-120	FP-128B	Mode 4	Mode 5	Mode 6	Mode 7
26	30	P10/PO8/TIOCA0/ DACK0/A20	P10/PO8/TIOCA0/ DACK0/A20	P10/PO8/TIOCA0/ DACK0/A20	P10/PO8/TIOCA0/ DACK0
27	31	P11/PO9/TIOCB0/ DACK1/A21	P11/PO9/TIOCB0/ DACK1/A21	P11/PO9/TIOCB0/ DACK1/A21	P11/PO9/TIOCB0/ DACK1
28	32	P12/PO10/TIOCC0/ TCLKA/A22	P12/PO10/TIOCC0/ TCLKA/A22	P12/PO10/TIOCC0/ TCLKA/A22	P12/PO10/TIOCC0/ TCLKA
29	33	P13/PO11/TIOCD0/ TCLKB/A23	P13/PO11/TIOCD0/ TCLKB/A23	P13/PO11/TIOCD0/ TCLKB/A23	P13/PO11/TIOCD0/ TCLKB
30	34	P14/PO12/TIOCA1/ IRQ0	P14/PO12/TIOCA1/ IRQ0	P14/PO12/TIOCA1/ IRQ0	P14/PO12/TIOCA1/ IRQ0
—	35	NC	NC	NC	NC
—	36	NC	NC	NC	NC
31	37	P15/PO13/TIOCB1/ TCLKC	P15/PO13/TIOCB1/ TCLKC	P15/PO13/TIOCB1/ TCLKC	P15/PO13/TIOCB1/ TCLKC
32	38	P16/PO14/TIOCA2/ PWM2/IRQ1	P16/PO14/TIOCA2/ PWM2/IRQ1	P16/PO14/TIOCA2/ PWM2/IRQ1	P16/PO14/TIOCA2/ PWM2/IRQ1
33	39	P17/PO15/TIOCB2/ PWM3/TCLKD	P17/PO15/TIOCB2/ PWM3/TCLKD	P17/PO15/TIOCB2/ PWM3/TCLKD	P17/PO15/TIOCB2/ PWM3/TCLKD
34	40	D0	PE0/D0	PE0/D0	PE0
35	41	D1	PE1/D1	PE1/D1	PE1
36	42	D2	PE2/D2	PE2/D2	PE2
37	43	D3	PE3/D3	PE3/D3	PE3
38	44	D4	PE4/D4	PE4/D4	PE4
39	45	D5	PE5/D5	PE5/D5	PE5
40	46	D6	PE6/D6	PE6/D6	PE6
41	47	D7	PE7/D7	PE7/D7	PE7
42	48	VSS	VSS	VSS	VSS
43	49	D8	D8	D8	PD0
44	50	PVCC1	PVCC1	PVCC1	PVCC1
45	51	D9	D9	D9	PD1
46	52	D10	D10	D10	PD2
47	53	D11	D11	D11	PD3
48	54	D12	D12	D12	PD4
49	55	D13	D13	D13	PD5
50	56	D14	D14	D14	PD6

Pin No.		Pin Name			
TFP-120	FP-128B	Mode 4	Mode 5	Mode 6	Mode 7
51	57	D15	D15	D15	PD7
52	58	P30/TxD0/IrTxD	P30/TxD0/IrTxD	P30/TxD0/IrTxD	P30/TxD0/IrTxD
53	59	P31/RxD0/IrRxD	P31/RxD0/IrRxD	P31/RxD0/IrRxD	P31/RxD0/IrRxD
54	60	PVCC2	PVCC2	PVCC2	PVCC2
55	61	P32/SCK0/SDA1/ IRQ4	P32/SCK0/SDA1/ IRQ4	P32/SCK0/SDA1/ IRQ4	P32/SCK0/SDA1/ IRQ4
56	62	VSS	VSS	VSS	VSS
57	63	P33/TxD1/SCL1	P33/TxD1/SCL1	P33/TxD1/SCL1	P33/TxD1/SCL1
58	64	P34/RxD1/SDA0	P34/RxD1/SDA0	P34/RxD1/SDA0	P34/RxD1/SDA0
59	65	P35/SCK1/SCK4/ SCL0/IRQ5	P35/SCK1/SCK4/ SCL0/IRQ5	P35/SCK1/SCK4/ SCL0/IRQ5	P35/SCK1/SCK4/ SCL0/IRQ5
60	66	P36/RxD4	P36/RxD4	P36/RxD4	P36/RxD4
—	67	NC	NC	NC	NC
—	68	NC	NC	NC	NC
61	69	P37/TxD4	P37/TxD4	P37/TxD4	P37/TxD4
62	70	PG0/CAS/IRQ6	PG0/CAS/IRQ6	PG0/CAS/IRQ6	PG0/IRQ6
63	71	PG1/CS3/OE/IRQ7	PG1/CS3/OE/IRQ7	PG1/CS3/OE/IRQ7	PG1/IRQ7
64	72	PG2/CS2	PG2/CS2	PG2/CS2	PG2
65	73	PG3/CS1	PG3/CS1	PG3/CS1	PG3
66	74	PG4/CS0	PG4/CS0	PG4/CS0	PG4
67	75	WDTOVF	WDTOVF	WDTOVF	WDTOVF
68	76	PLLVC	PLLVC	PLLVC	PLLVC
69	77	PLLCAP	PLLCAP	PLLCAP	PLLCAP
70	78	PLLVSS	PLLVSS	PLLVSS	PLLVSS
71	79	RES	RES	RES	RES
72	80	NMI	NMI	NMI	NMI
73	81	STBY	STBY	STBY	STBY
74	82	FWE*	FWE*	FWE*	FWE*
75	83	XTAL	XTAL	XTAL	XTAL
76	84	VCC	VCC	VCC	VCC
77	85	EXTAL	EXTAL	EXTAL	EXTAL
78	86	VSS	VSS	VSS	VSS



Pin No.		Pin Name			
TFP-120	FP-128B	Mode 4	Mode 5	Mode 6	Mode 7
79	87	OSC1	OSC1	OSC1	OSC1
80	88	OSC2	OSC2	OSC2	OSC2
81	89	PVCC1	PVCC1	PVCC1	PVCC1
82	90	PF7/∅	PF7/∅	PF7/∅	PF7/∅
83	91	VSS	VSS	VSS	VSS
84	92	AS/LCAS	AS/LCAS	AS/LCAS	PF6
85	93	RD	RD	RD	PF5
86	94	HWR	HWR	HWR	PF4
87	95	LWR	PF3/LWR/ADTRG/ IRQ3	PF3/LWR/ADTRG/ IRQ3	PF3/ADTRG/IRQ3
88	96	PF2/LCAS/WAIT/ BREQO	PF2/LCAS/WAIT/ BREQO	PF2/LCAS/WAIT/ BREQO	PF2
89	97	PF1/BACK/BUZZ	PF1/BACK/BUZZ	PF1/BACK/BUZZ	PF1/BUZZ
90	98	PF0/BREQ/IRQ2	PF0/BREQ/IRQ2	PF0/BREQ/IRQ2	PF0/IRQ2
—	99	NC	NC	NC	NC
—	100	NC	NC	NC	NC
91	101	AVCC	AVCC	AVCC	AVCC
92	102	Vref	Vref	Vref	Vref
93	103	P40/AN0	P40/AN0	P40/AN0	P40/AN0
94	104	P41/AN1	P41/AN1	P41/AN1	P41/AN1
95	105	P42/AN2	P42/AN2	P42/AN2	P42/AN2
96	106	P43/AN3	P43/AN3	P43/AN3	P43/AN3
97	107	P44/AN4	P44/AN4	P44/AN4	P44/AN4
98	108	P45/AN5	P45/AN5	P45/AN5	P45/AN5
99	109	P46/AN6/DA0	P46/AN6/DA0	P46/AN6/DA0	P46/AN6/DA0
100	110	P47/AN7/DA1	P47/AN7/DA1	P47/AN7/DA1	P47/AN7/DA1
101	111	P90/AN8	P90/AN8	P90/AN8	P90/AN8
102	112	P91/AN9	P91/AN9	P91/AN9	P91/AN9
103	113	P92/AN10	P92/AN10	P92/AN10	P92/AN10
104	114	P93/AN11	P93/AN11	P93/AN11	P93/AN11
105	115	P94/AN12	P94/AN12	P94/AN12	P94/AN12
106	116	P95/AN13	P95/AN13	P95/AN13	P95/AN13

Pin No.		Pin Name			
TFP-120	FP-128B	Mode 4	Mode 5	Mode 6	Mode 7
107	117	P96/AN14/DA2	P96/AN14/DA2	P96/AN14/DA2	P96/AN14/DA2
108	118	P97/AN15/DA3	P97/AN15/DA3	P97/AN15/DA3	P97/AN15/DA3
109	119	AVSS	AVSS	AVSS	AVSS
110	120	P70/TMRI01/TMCI01/ DREQ0/CS4	P70/TMRI01/TMCI01/ DREQ0/CS4	P70/TMRI01/TMCI01/ DREQ0/CS4	P70/TMRI01/TMCI01/ DREQ0
111	121	P71/TMRI23/TMCI23/ DREQ1/CS5	P71/TMRI23/TMCI23/ DREQ1/CS5	P71/TMRI23/TMCI23/ DREQ1/CS5	P71/TMRI23/TMCI23/ DREQ1
112	122	P72/TMO0/TEND0/ CS6/SYNCI	P72/TMO0/TEND0/ CS6/SYNCI	P72/TMO0/TEND0/ CS6/SYNCI	P72/TMO0/TEND0/ SYNCI
113	123	P73/TMO1/TEND1/ CS7	P73/TMO1/TEND1/ CS7	P73/TMO1/TEND1/ CS7	P73/TMO1/TEND1
114	124	P74/TMO2/MRES	P74/TMO2/MRES	P74/TMO2/MRES	P74/TMO2/MRES
115	125	P75/TMO3/SCK3	P75/TMO3/SCK3	P75/TMO3/SCK3	P75/TMO3/SCK3
116	126	P76/RxD3	P76/RxD3	P76/RxD3	P76/RxD3
117	127	P77/TxD3	P77/TxD3	P77/TxD3	P77/TxD3
118	128	MD0	MD0	MD0	MD0
119	1	MD1	MD1	MD1	MD1
120	2	MD2	MD2	MD2	MD2
—	3	NC	NC	NC	NC
—	4	NC	NC	NC	NC

Notes: NC pins should be connected to VSS or left open.

- \* FWE is used only in the flash memory version. Leave open or connect VSS in the mask ROM version.

**Table 1-2 (b) Pin Functions in Each Operating Mode (H8S/2633R)**

Pin No.		Pin Name			
TFP-120	FP-128B	Mode 4	Mode 5	Mode 6	Mode 7
1	5	A0	A0	PC0/A0	PC0
2	6	A1	A1	PC1/A1	PC1
3	7	A2	A2	PC2/A2	PC2
4	8	A3	A3	PC3/A3	PC3
5	9	VSS	VSS	VSS	VSS
6	10	A4	A4	PC4/A4	PC4
7	11	VCL	VCL	VCL	VCL
8	12	A5	A5	PC5/A5	PC5
9	13	A6	A6	PC6/A6/PWM0	PC6/PWM0
10	14	A7	A7	PC7/A7/PWM1	PC7/PWM1
11	15	VSS	VSS	VSS	VSS
12	16	A8	A8	PB0/A8/TIOCA3	PB0/TIOCA3
13	17	PVCC1	PVCC1	PVCC1	PVCC1
14	18	A9	A9	PB1/A9/TIOCB3	PB1/TIOCB3
15	19	A11	A11	PB3/A11/TIOCD3	PB3/TIOCD3
17	21	A12	A12	PB4/A12/TIOCA4	PB4/TIOCA4
18	22	A13	A13	PB5/A13/TIOCB4	PB5/TIOCB4
19	23	A14	A14	PB6/A14/TIOCA5	PB6/TIOCA5
20	24	A15	A15	PB7/A15/TIOCB5	PB7/TIOCB5
21	25	A16	A16	PA0/A16	PA0
22	26	A17	A17	PA1/A17/TxD2	PA1/TxD2
23	27	A18	A18	PA2/A18/RxD2	PA2/RxD2
24	28	A19	A19	PA3/A19/SCK2	PA3/SCK2
25	29	VSS	VSS	VSS	VSS
26	30	P10/PO8/TIOCA0/ DACK0/A20	P10/PO8/TIOCA0/ DACK0/A20	P10/PO8/TIOCA0/ DACK0/A20	P10/PO8/TIOCA0/ DACK0
27	31	P11/PO9/TIOCB0/ DACK1/A21	P11/PO9/TIOCB0/ DACK1/A21	P11/PO9/TIOCB0/ DACK1/A21	P11/PO9/TIOCB0/ DACK1

Pin No.		Pin Name			
TFP-120	FP-128B	Mode 4	Mode 5	Mode 6	Mode 7
28	32	P12/PO10/TIOCC0/ TCLKA/A22	P12/PO10/TIOCC0/ TCLKA/A22	P12/PO10/TIOCC0/ TCLKA/A22	P12/PO10/TIOCC0/ TCLKA
29	33	P13/PO11/TIOCD0/ TCLKB/A23	P13/PO11/TIOCD0/ TCLKB/A23	P13/PO11/TIOCD0/ TCLKB/A23	P13/PO11/TIOCD0/ TCLKB
30	34	P14/PO12/TIOCA1/ IRQ0	P14/PO12/TIOCA1/ IRQ0	P14/PO12/TIOCA1/ IRQ0	P14/PO12/TIOCA1/ IRQ0
—	35	NC	NC	NC	NC
—	36	NC	NC	NC	NC
31	37	P15/PO13/TIOCB1/ TCLKC	P15/PO13/TIOCB1/ TCLKC	P15/PO13/TIOCB1/ TCLKC	P15/PO13/TIOCB1/ TCLKC
32	38	P16/PO14/TIOCA2/ PWM2/IRQ1	P16/PO14/TIOCA2/ PWM2/IRQ1	P16/PO14/TIOCA2/ PWM2/IRQ1	P16/PO14/TIOCA2/ PWM2/IRQ1
33	39	P17/PO15/TIOCB2/ PWM3/TCLKD	P17/PO15/TIOCB2/ PWM3/TCLKD	P17/PO15/TIOCB2/ PWM3/TCLKD	P17/PO15/TIOCB2/ PWM3/TCLKD
34	40	D0	PE0/D0	PE0/D0	PE0
35	41	D1	PE1/D1	PE1/D1	PE1
36	42	D2	PE2/D2	PE2/D2	PE2
37	43	D3	PE3/D3	PE3/D3	PE3
38	44	D4	PE4/D4	PE4/D4	PE4
39	45	D5	PE5/D5	PE5/D5	PE5
40	46	D6	PE6/D6	PE6/D6	PE6
41	47	D7	PE7/D7	PE7/D7	PE7
42	48	VSS	VSS	VSS	VSS
43	49	D8	D8	D8	PD0
44	50	PVCC1	PVCC1	PVCC1	PVCC1
45	51	D9	D9	D9	PD1
46	52	D10	D10	D10	PD2
47	53	D11	D11	D11	PD3
48	54	D12	D12	D12	PD4
49	55	D13	D13	D13	PD5
50	56	D14	D14	D14	PD6
51	57	D15	D15	D15	PD7
52	58	P30/TxD0/IrTxD	P30/TxD0/IrTxD	P30/TxD0/IrTxD	P30/TxD0/IrTxD

Pin No.		Pin Name			
TFP-120	FP-128B	Mode 4	Mode 5	Mode 6	Mode 7
53	59	P31/RxD0/IrRxD	P31/RxD0/IrRxD	P31/RxD0/IrRxD	P31/RxD0/IrRxD
54	60	PVCC2	PVCC2	PVCC2	PVCC2
55	61	P32/SCK0/SDA1/ IRQ4	P32/SCK0/SDA1/ IRQ4	P32/SCK0/SDA1/ IRQ4	P32/SCK0/SDA1/ IRQ4
56	62	VSS	VSS	VSS	VSS
57	63	P33/TxD1/SCL1	P33/TxD1/SCL1	P33/TxD1/SCL1	P33/TxD1/SCL1
58	64	P34/RxD1/SDA0	P34/RxD1/SDA0	P34/RxD1/SDA0	P34/RxD1/SDA0
59	65	P35/SCK1/SCK4/ SCL0/IRQ5	P35/SCK1/SCK4/ SCL0/IRQ5	P35/SCK1/SCK4/ SCL0/IRQ5	P35/SCK1/SCK4/ SCL0/IRQ5
60	66	P36/RxD4	P36/RxD4	P36/RxD4	P36/RxD4
—	67	NC	NC	NC	NC
—	68	NC	NC	NC	NC
61	69	P37/TxD4	P37/TxD4	P37/TxD4	P37/TxD4
62	70	PG0/CAS/IRQ6	PG0/CAS/IRQ6	PG0/CAS/IRQ6	PG0/IRQ6
63	71	PG1/CS3/OE/IRQ7	PG1/CS3/OE/IRQ7	PG1/CS3/OE/IRQ7	PG1/IRQ7
64	72	PG2/CS2	PG2/CS2	PG2/CS2	PG2
65	73	PG3/CS1	PG3/CS1	PG3/CS1	PG3
66	74	PG4/CS0	PG4/CS0	PG4/CS0	PG4
67	75	WDTOVF	WDTOVF	WDTOVF	WDTOVF
68	76	NC	NC	NC	NC
69	77	PLLCAP	PLLCAP	PLLCAP	PLLCAP
70	78	PLLVSS	PLLVSS	PLLVSS	PLLVSS
71	79	RES	RES	RES	RES
72	80	NMI	NMI	NMI	NMI
73	81	STBY	STBY	STBY	STBY
74	82	FWE	FWE	FWE	FWE
75	83	XTAL	XTAL	XTAL	XTAL
76	84	NC	NC	NC	NC
77	85	EXTAL	EXTAL	EXTAL	EXTAL
78	86	VSS	VSS	VSS	VSS
79	87	OSC1	OSC1	OSC1	OSC1

Pin No.		Pin Name			
TFP-120	FP-128B	Mode 4	Mode 5	Mode 6	Mode 7
80	88	OSC2	OSC2	OSC2	OSC2
81	89	PVCC1	PVCC1	PVCC1	PVCC1
82	90	PF7/ $\emptyset$	PF7/ $\emptyset$	PF7/ $\emptyset$	PF7/ $\emptyset$
83	91	VSS	VSS	VSS	VSS
84	92	$\overline{AS/LCAS}$	$\overline{AS/LCAS}$	$\overline{AS/LCAS}$	PF6
85	93	$\overline{RD}$	$\overline{RD}$	$\overline{RD}$	PF5
86	94	$\overline{HWR}$	$\overline{HWR}$	$\overline{HWR}$	PF4
87	95	$\overline{LWR}$	PF3/ $\overline{LWR/ADTRG/IRQ3}$	PF3/ $\overline{LWR/ADTRG/IRQ3}$	PF3/ $\overline{ADTRG/IRQ3}$
88	96	PF2/ $\overline{LCAS/WAIT/BREQO}$	PF2/ $\overline{LCAS/WAIT/BREQO}$	PF2/ $\overline{LCAS/WAIT/BREQO}$	PF2
89	97	PF1/ $\overline{BACK/BUZZ}$	PF1/ $\overline{BACK/BUZZ}$	PF1/ $\overline{BACK/BUZZ}$	PF1/ $\overline{BUZZ}$
90	98	PF0/ $\overline{BREQ/IRQ2}$	PF0/ $\overline{BREQ/IRQ2}$	PF0/ $\overline{BREQ/IRQ2}$	PF0/ $\overline{IRQ2}$
—	99	NC	NC	NC	NC
—	100	NC	NC	NC	NC
91	101	AVCC	AVCC	AVCC	AVCC
92	102	Vref	Vref	Vref	Vref
93	103	P40/AN0	P40/AN0	P40/AN0	P40/AN0
94	104	P41/AN1	P41/AN1	P41/AN1	P41/AN1
95	105	P42/AN2	P42/AN2	P42/AN2	P42/AN2
96	106	P43/AN3	P43/AN3	P43/AN3	P43/AN3
97	107	P44/AN4	P44/AN4	P44/AN4	P44/AN4
98	108	P45/AN5	P45/AN5	P45/AN5	P45/AN5
99	109	P46/AN6/DA0	P46/AN6/DA0	P46/AN6/DA0	P46/AN6/DA0
100	110	P47/AN7/DA1	P47/AN7/DA1	P47/AN7/DA1	P47/AN7/DA1
101	111	P90/AN8	P90/AN8	P90/AN8	P90/AN8
102	112	P91/AN9	P91/AN9	P91/AN9	P91/AN9
103	113	P92/AN10	P92/AN10	P92/AN10	P92/AN10
104	114	P93/AN11	P93/AN11	P93/AN11	P93/AN11
105	115	P94/AN12	P94/AN12	P94/AN12	P94/AN12
106	116	P95/AN13	P95/AN13	P95/AN13	P95/AN13

Pin No.		Pin Name			
TFP-120	FP-128B	Mode 4	Mode 5	Mode 6	Mode 7
107	117	P96/AN14/DA2	P96/AN14/DA2	P96/AN14/DA2	P96/AN14/DA2
108	118	P97/AN15/DA3	P97/AN15/DA3	P97/AN15/DA3	P97/AN15/DA3
109	119	AVSS	AVSS	AVSS	AVSS
110	120	P70/TMRI01/TMCI01/ DREQ0/CS4	P70/TMRI01/TMCI01/ DREQ0/CS4	P70/TMRI01/TMCI01/ DREQ0/CS4	P70/TMRI01/TMCI01/ DREQ0
111	121	P71/TMRI23/TMCI23/ DREQ1/CS5	P71/TMRI23/TMCI23/ DREQ1/CS5	P71/TMRI23/TMCI23/ DREQ1/CS5	P71/TMRI23/TMCI23/ DREQ1
112	122	P72/TMO0/TEND0/ CS6/SYNCI	P72/TMO0/TEND0/ CS6/SYNCI	P72/TMO0/TEND0/ CS6/SYNCI	P72/TMO0/TEND0/ SYNCI
113	123	P73/TMO1/TEND1/ CS7	P73/TMO1/TEND1/ CS7	P73/TMO1/TEND1/ CS7	P73/TMO1/TEND1
114	124	P74/TMO2/MRES	P74/TMO2/MRES	P74/TMO2/MRES	P74/TMO2/MRES
115	125	P75/TMO3/SCK3	P75/TMO3/SCK3	P75/TMO3/SCK3	P75/TMO3/SCK3
116	126	P76/RxD3	P76/RxD3	P76/RxD3	P76/RxD3
117	127	P77/TxD3	P77/TxD3	P77/TxD3	P77/TxD3
118	128	MD0	MD0	MD0	MD0
119	1	MD1	MD1	MD1	MD1
120	2	MD2	MD2	MD2	MD2
—	3	NC	NC	NC	NC
—	4	NC	NC	NC	NC

Note: NC pins should be connected to VSS or left open.

**Table 1-2 (c) Pin Functions in Each Operating Mode (H8S/2695)**

Pin No.	Pin Name				
	FP-128B	Mode 4	Mode 5	Mode 6	Mode 7
5		A0	A0	PC0/A0	PC0
6		A1	A1	PC1/A1	PC1
7		A2	A2	PC2/A2	PC2
8		A3	A3	PC3/A3	PC3
9		VSS	VSS	VSS	VSS
10		A4	A4	PC4/A4	PC4
11		VCL	VCL	VCL	VCL
12		A5	A5	PC5/A5	PC5
13		A6	A6	PC6/A6	PC6
14		A7	A7	PC7/A7	PC7
15		VSS	VSS	VSS	VSS
16		A8	A8	PB0/A8/TIOCA3	PB0/TIOCA3
17		PVCC1	PVCC1	PVCC1	PVCC1
18		A9	A9	PB1/A9/TIOCB3	PB1/TIOCB3
19		A10	A10	PB2/A10/TIOCC3	PB2/TIOCC3
20		A11	A11	PB3/A11/TIOCD3	PB3/TIOCD3
21		A12	A12	PB4/A12/TIOCA4	PB4/TIOCA4
22		A13	A13	PB5/A13/TIOCB4	PB5/TIOCB4
23		A14	A14	PB6/A14/TIOCA5	PB6/TIOCA5
24		A15	A15	PB7/A15/TIOCB5	PB7/TIOCB5
25		A16	A16	PA0/A16	PA0
26		A17	A17	PA1/A17/TxD2	PA1/TxD2
27		A18	A18	PA2/A18/RxD2	PA2/RxD2
28		A19	A19	PA3/A19/SCK2	PA3/SCK2
29		VSS	VSS	VSS	VSS
30		P10/TIOCA0/A20	P10/TIOCA0/A20	P10/TIOCA0/A20	P10/TIOCA0
31		P11/TIOCB0/A21	P11/TIOCB0/A21	P11/TIOCB0/A21	P11/TIOCB0
32		P12/TIOCC0/ TCLKA/A22	P12/TIOCC0/ TCLKA/A22	P12/TIOCC0/ TCLKA/A22	P12/TIOCC0/ TCLKA
33		P13/TIOCD0/ TCLKB/A23	P13/TIOCD0/ TCLKB/A23	P13/TIOCD0/ TCLKB/A23	P13/TIOCD0/ TCLKB
34		P14/TIOCA1/ $\overline{\text{IRQ0}}$	P14/TIOCA1/ $\overline{\text{IRQ0}}$	P14/TIOCA1/ $\overline{\text{IRQ0}}$	P14/TIOCA1/ $\overline{\text{IRQ0}}$



Pin No.	Pin Name			
	Mode 4	Mode 5	Mode 6	Mode 7
FP-128B				
35	NC	NC	NC	NC
36	NC	NC	NC	NC
37	P15/TIOCB1/TCLKC	P15/TIOCB1/TCLKC	P15/TIOCB1/TCLKC	P15/TIOCB1/TCLKC
38	P16/TIOCA2/ $\overline{\text{IRQ1}}$	P16/TIOCA2/ $\overline{\text{IRQ1}}$	P16/TIOCA2/ $\overline{\text{IRQ1}}$	P16/TIOCA2/ $\overline{\text{IRQ1}}$
39	P17/TIOCB2/TCLKD	P17/TIOCB2/TCLKD	P17/TIOCB2/TCLKD	P17/TIOCB2/TCLKD
40	D0	PE0/D0	PE0/D0	PE0
41	D1	PE1/D1	PE1/D1	PE1
42	D2	PE2/D2	PE2/D2	PE2
43	D3	PE3/D3	PE3/D3	PE3
44	D4	PE4/D4	PE4/D4	PE4
45	D5	PE5/D5	PE5/D5	PE5
46	D6	PE6/D6	PE6/D6	PE6
47	D7	PE7/D7	PE7/D7	PE7
48	VSS	VSS	VSS	VSS
49	D8	D8	D8	PD0
50	PVCC1	PVCC1	PVCC1	PVCC1
51	D9	D9	D9	PD1
52	D10	D10	D10	PD2
53	D11	D11	D11	PD3
54	D12	D12	D12	PD4
55	D13	D13	D13	PD5
56	D14	D14	D14	PD6
57	D15	D15	D15	PD7
58	P30/TxD0	P30/TxD0	P30/TxD0	P30/TxD0
59	P31/RxD0	P31/RxD0	P31/RxD0	P31/RxD0
60	PVCC2	PVCC2	PVCC2	PVCC2
61	P32/SCK0/ $\overline{\text{IRQ4}}$	P32/SCK0/ $\overline{\text{IRQ4}}$	P32/SCK0/ $\overline{\text{IRQ4}}$	P32/SCK0/ $\overline{\text{IRQ4}}$
62	VSS	VSS	VSS	VSS
63	P33/TxD1	P33/TxD1	P33/TxD1	P33/TxD1
64	P34/RxD1	P34/RxD1	P34/RxD1	P34/RxD1
65	P35/SCK1/SCK4/ $\overline{\text{IRQ5}}$	P35/SCK1/SCK4/ $\overline{\text{IRQ5}}$	P35/SCK1/SCK4/ $\overline{\text{IRQ5}}$	P35/SCK1/SCK4/ $\overline{\text{IRQ5}}$

Pin No.	Pin Name			
	Mode 4	Mode 5	Mode 6	Mode 7
66	P36/RxD4	P36/RxD4	P36/RxD4	P36/RxD4
67	NC	NC	NC	NC
68	NC	NC	NC	NC
69	P37/TxD4	P37/TxD4	P37/TxD4	P37/TxD4
70	PG0/IRQ6	PG0/IRQ6	PG0/IRQ6	PG0/IRQ6
71	PG1/CS3/IRQ7	PG1/CS3/IRQ7	PG1/CS3/IRQ7	PG1/IRQ7
72	PG2/CS2	PG2/CS2	PG2/CS2	PG2
73	PG3/CS1	PG3/CS1	PG3/CS1	PG3
74	PG4/CS0	PG4/CS0	PG4/CS0	PG4
75	WDTOVF	WDTOVF	WDTOVF	WDTOVF
76	NC	NC	NC	NC
77	PLLCAP	PLLCAP	PLLCAP	PLLCAP
78	PLLSS	PLLSS	PLLSS	PLLSS
79	RES	RES	RES	RES
80	NMI	NMI	NMI	NMI
81	STBY	STBY	STBY	STBY
82	NC*	NC*	NC*	NC*
83	XTAL	XTAL	XTAL	XTAL
84	NC	NC	NC	NC
85	EXTAL	EXTAL	EXTAL	EXTAL
86	VSS	VSS	VSS	VSS
87	NC	NC	NC	NC
88	NC	NC	NC	NC
89	PVCC1	PVCC1	PVCC1	PVCC1
90	PF7/Ø	PF7/Ø	PF7/Ø	PF7/Ø
91	VSS	VSS	VSS	VSS
92	AS	AS	AS	PF6
93	RD	RD	RD	PF5
94	HWR	HWR	HWR	PF4
95	LWR	PF3/LWR/ADTRG/ IRQ3	PF3/LWR/ADTRG/ IRQ3	PF3/ADTRG/IRQ3
96	PF2/WAIT/BREQO	PF2/WAIT/BREQO	PF2/WAIT/BREQO	PF2

Pin No.	Pin Name			
	Mode 4	Mode 5	Mode 6	Mode 7
97	PF1/ $\overline{\text{BACK}}$	PF1/ $\overline{\text{BACK}}$	PF1/ $\overline{\text{BACK}}$	PF1
98	PF0/BREQ/ $\overline{\text{IRQ2}}$	PF0/BREQ/ $\overline{\text{IRQ2}}$	PF0/BREQ/ $\overline{\text{IRQ2}}$	PF0/ $\overline{\text{IRQ2}}$
99	NC	NC	NC	NC
100	NC	NC	NC	NC
101	AVCC	AVCC	AVCC	AVCC
102	Vref	Vref	Vref	Vref
103	P40/AN0	P40/AN0	P40/AN0	P40/AN0
104	P41/AN1	P41/AN1	P41/AN1	P41/AN1
105	P42/AN2	P42/AN2	P42/AN2	P42/AN2
106	P43/AN3	P43/AN3	P43/AN3	P43/AN3
107	P44/AN4	P44/AN4	P44/AN4	P44/AN4
108	P45/AN5	P45/AN5	P45/AN5	P45/AN5
109	P46/AN6	P46/AN6	P46/AN6	P46/AN6
110	P47/AN7	P47/AN7	P47/AN7	P47/AN7
111	P90/AN8	P90/AN8	P90/AN8	P90/AN8
112	P91/AN9	P91/AN9	P91/AN9	P91/AN9
113	P92/AN10	P92/AN10	P92/AN10	P92/AN10
114	P93/AN11	P93/AN11	P93/AN11	P93/AN11
115	P94/AN12	P94/AN12	P94/AN12	P94/AN12
116	P95/AN13	P95/AN13	P95/AN13	P95/AN13
117	P96/AN14	P96/AN14	P96/AN14	P96/AN14
118	P97/AN15	P97/AN15	P97/AN15	P97/AN15
119	AVSS	AVSS	AVSS	AVSS
120	P70/ $\overline{\text{CS4}}$	P70/ $\overline{\text{CS4}}$	P70/ $\overline{\text{CS4}}$	P70
121	P71/ $\overline{\text{CS5}}$	P71/ $\overline{\text{CS5}}$	P71/ $\overline{\text{CS5}}$	P71
122	P72/ $\overline{\text{CS6}}$	P72/ $\overline{\text{CS6}}$	P72/ $\overline{\text{CS6}}$	P72
123	P73/ $\overline{\text{CS7}}$	P73/ $\overline{\text{CS7}}$	P73/ $\overline{\text{CS7}}$	P73
124	P74/ $\overline{\text{MRES}}$	P74/ $\overline{\text{MRES}}$	P74/ $\overline{\text{MRES}}$	P74/ $\overline{\text{MRES}}$
125	P75/SCK3	P75/SCK3	P75/SCK3	P75/SCK3
126	P76/RxD3	P76/RxD3	P76/RxD3	P76/RxD3
127	P77/TxD3	P77/TxD3	P77/TxD3	P77/TxD3

Pin No.	Pin Name			
	Mode 4	Mode 5	Mode 6	Mode 7
FP-128B	MD0	MD0	MD0	MD0
128	MD0	MD0	MD0	MD0
1	MD1	MD1	MD1	MD1
2	MD2	MD2	MD2	MD2
3	NC	NC	NC	NC
4	NC	NC	NC	NC

Notes: NC pins should be connected to VSS or left open.

\* In the flash memory version this is the FWE pin.

### 1.3.3 Pin Functions

Table 1-3 (a) outlines the pin functions of the H8S/2633, H8S/2632, H8S/2631 and H8S/2633F. Table 1-3 (b) outlines the pin functions of the H8S/2633R. Table 1-3 (c) outlines the pin functions of the H8S/2695.

**Table 1-3 (a) Pin Functions (H8S/2633, H8S/2632, H8S/2631, H8S/2633F)**

Type	Symbol	I/O	Name and Function
Power	VCC	Input	Power supply: For connection to the power supply. All VCC pins should be connected to the system power supply.
	PVCC1, PVCC2	Input	Port power supply pin. Connect all pins to the same power supply.
	VSS	Input	Ground: For connection to ground (0 V). All VSS pins should be connected to the system power supply (0 V).
Clock	PLLVCC	Input	PLL power supply: Power supply for on-chip PLL oscillator.
	PLLVSS	Input	PLL ground: Ground for on-chip PLL oscillator.
	PLLCAP	Input	PLL capacitance: External capacitance pin for on-chip PLL oscillator.
	XTAL	Input	Connects to a crystal oscillator. See section 23A, Clock Pulse Generator (H8S/2633, H8S/2632, H8S/2631, H8S/2633F), for typical connection diagrams for a crystal oscillator and external clock input.
	EXTAL	Input	Connects to a crystal oscillator. The EXTAL pin can also input an external clock. See section 23A, Clock Pulse Generator (H8S/2633, H8S/2632, H8S/2631, H8S/2633F), for typical connection diagrams for a crystal oscillator and external clock input.
	OSC1	Input	Subclock: Connects to a 32.768 kHz crystal oscillator. See section 23A, Clock Pulse Generator (H8S/2633, H8S/2632, H8S/2631, H8S/2633F), for examples of connections to a crystal oscillator.
	OSC2	Input	Subclock: Connects to a 32.768 kHz crystal oscillator. See section 23A, Clock Pulse Generator (H8S/2633, H8S/2632, H8S/2631, H8S/2633F), for examples of connections to a crystal oscillator.
	∅	Output	System clock: Supplies the system clock to an external device.

Type	Symbol	I/O	Name and Function			
Operating mode control	MD2 to MD0	Input	Mode pins: These pins set the operating mode. The relation between the settings of pins MD2 to MD0 and the operating mode is shown below. These pins should not be changed while the H8S/2633 Series is operating.			
			<b>MD2</b>	<b>MD1</b>	<b>MD0</b>	<b>Operating Mode</b>
			0	0	0	—
					1	—
				1	0	—
					1	—
			1	0	0	Mode 4
					1	Mode 5
				1	0	Mode 6
					1	Mode 7
System control	$\overline{\text{RES}}$	Input	Reset input: When this pin is driven low, the chip is reset.			
	$\overline{\text{MRES}}$	Input	Manual reset: When this pin is driven low, a transmission is made to manual reset mode.			
	$\overline{\text{STBY}}$	Input	Standby: When this pin is driven low, a transition is made to hardware standby mode.			
	$\overline{\text{BREQ}}$	Input	Bus request: Used by an external bus master to issue a bus request to the H8S/2633 Series.			
	$\overline{\text{BREQO}}$	Output	Bus request output: The external bus request signal used when an internal bus master accesses external space in the external bus-released state.			
	$\overline{\text{BACK}}$	Output	Bus request acknowledge: Indicates that the bus has been released to an external bus master.			
	FWE	Input	Flash write enable: Pin for flash memory use (in planning stage).			

Type	Symbol	I/O	Name and Function
Interrupts	NMI	Input	Nonmaskable interrupt: Requests a nonmaskable interrupt. When this pin is not used, it should be fixed high.
	$\overline{\text{IRQ7}}$ to $\overline{\text{IRQ0}}$	Input	Interrupt request 7 to 0: These pins request a maskable interrupt.
Address bus	A23 to A0	Output	Address bus: These pins output an address.
Data bus	D15 to D0	I/O	Data bus: These pins constitute a bidirectional data bus.
Bus control	$\overline{\text{CS7}}$ to $\overline{\text{CS0}}$	Output	Chip select: Selection signal for areas 0 to 7.
	$\overline{\text{AS}}$	Output	Address strobe: When this pin is low, it indicates that address output on the address bus is enabled.
	$\overline{\text{RD}}$	Output	Read: When this pin is low, it indicates that the external address space can be read.
	$\overline{\text{HWR}}$	Output	High write/write enable/upper write enable: A strobe signal that writes to external space and indicates that the upper half (D15 to D8) of the data bus is enabled. The 2CAS type DRAM write enable signal. The 2WE type DRAM upper write enable signal.
	$\overline{\text{LWR}}$	Output	Low write/lower column address strobe/lower write enable: A strobe signal that writes to external space and indicates that the lower half (D7 to D0) of the data bus is enabled. The 2CAS type (LCASS = 1) DRAM lower column address strobe signal. The 2WE type DRAM lower write enable signal.
	$\overline{\text{CAS}}$	Output	Upper column address strobe/column address strobe: The 2CAS type DRAM upper column address strobe signal.
	$\overline{\text{LCAS}}$	Output	Lower column address strobe: The 2CAS type DRAM lower column address strobe signal.
	$\overline{\text{OE}}$	Output	Output enable: Output enable signal for DRAM space read access.
	$\overline{\text{WAIT}}$	Input	Wait: Requests insertion of a wait state in the bus cycle when accessing external 3-state address space.

Type	Symbol	I/O	Name and Function
DMA controller (DMAC)	DREQ1, DREQ0	Input	DMA request 1,0: Requests DMAC activation.
	TEND1, TEND0	Output	DMA transfer completed 1,0: Indicates DMAC data transfer end.
	DACK1, DACK0	Output	DMA transfer acknowledge 1,0: DMAC single address transfer acknowledge pin.
16-bit timer-pulse unit (TPU)	TCLKD to TCLKA	Input	Clock input D to A: These pins input an external clock.
	TIOCA0, TIOCB0, TIOCC0, TIOCD0	I/O	Input capture/ output compare match A0 to D0: The TGR0A to TGR0D input capture input or output compare output, or PWM output pins.
	TIOCA1, TIOCB1	I/O	Input capture/ output compare match A1 and B1: The TGR1A and TGR1B input capture input or output compare output, or PWM output pins.
	TIOCA2, TIOCB2	I/O	Input capture/ output compare match A2 and B2: The TGR2A and TGR2B input capture input or output compare output, or PWM output pins.
	TIOCA3, TIOCB3, TIOCC3, TIOCD3	I/O	Input capture/ output compare match A3 to D3: The TGR3A to TGR3D input capture input or output compare output, or PWM output pins.
	TIOCA4, TIOCB4	I/O	Input capture/output compare match A4 and B4: The TGR4A and TGR4B input capture input or output compare output, or PWM output pins.
	TIOCA5, TIOCB5	I/O	Input capture/output compare match A5 and B5: The TGR5A and TGR5B input capture input or output compare output, or PWM output pins.
Programmable pulse generator (PPG)	PO15 to PO8	Output	Pulse output 15 to 8: Pulse output pins.
8-bit timer	TMO0 to TMO3	Output	Compare match output: The compare match output pins.
	TMCI01, TMCI23	Input	Counter external clock input: Input pins for the external clock input to the counter.
	TMRI01, TMRI23	Input	Counter external reset input: The counter reset input pins.



Type	Symbol	I/O	Name and Function
14-bit PWM timer (PWMX)	PWM0 to PWM3	Output	PWMX timer output: PWM D/A pulse output pins.
Watchdog timer (WDT)	$\overline{\text{WDTOVF}}$	Output	Watchdog timer overflows: The counter overflows signal output pin in watchdog timer mode.
	BUZZ	Output	BUZZ output: Output pins for the pulse divided by the watchdog timer.
Serial communication interface (SCI)/ Smart Card interface	TxD4, TxD3, TxD2, TxD1, TxD0	Output	Transmit data (channel 0, 1, 2): Data output pins.
	RxD4, RxD3, RxD2, RxD1, RxD0	Input	Receive data (channel 0, 1, 2): Data input pins.
	SCK4, SCK3, SCK2, SCK1, SCK0	I/O	Serial clock (channel 0, 1, 2): Clock I/O pins. SCK0 output type is NMOS push-pull.
IrDA-equipped SCI 1 channel (SCI0)	IrTxD, IrRxD	Output/ Input	IrDA transmission data/receive data: Input/output pins for the data encoded for the IrDA.
I <sup>2</sup> C bus interface (IIC) (optional)	SCL0, SCL1	I/O	I <sup>2</sup> C clock input (channel 1, 0): I <sup>2</sup> C clock input/output pins. These functions have a bus driving function. SCL0's output format is an NMOS open drain.
	SDA0, SDA1	I/O	I <sup>2</sup> C data input/output (channel 1, 0): I <sup>2</sup> C clock input/output pins. These functions have a bus driving function. SCL0's output format is an NMOS open drain.
A/D converter	AN15 to AN0	Input	Analog 15 to 0: Analog input pins.
	$\overline{\text{ADTRG}}$	Input	A/D conversion external trigger input: Pin for input of an external trigger to start A/D conversion.
D/A converter	DA3 to DA0	Output	Analog output: Analog output pins for D/A converter.
A/D converter, D/A converter	AVCC	Input	A/D converter and D/A converter power supply pin. When the A/D converter and D/A converter are not used, this pin should be connected to the system power supply (+5 V).

Type	Symbol	I/O	Name and Function
A/D converter, D/A converter	AVSS	Input	Analog circuit ground and reference voltage A/D converter and D/A converter ground and reference voltage. Connect to system power supply (0 V).
	Vref	Input	A/D converter and D/A converter reference voltage input pin. When the A/D converter and D/A converter are not used, this pin should be connected to the system power supply (+5 V).
I/O ports	P17 to P10	I/O	Port 1: An 8-bit I/O port. Input or output can be designated for each bit by means of the port 1 data direction register (P1DDR).
	P37 to P30	I/O	Port 3: An 8-bit I/O port. Input or output can be designated for each bit by means of the port 3 data direction register (P3DDR).
	P47 to P40	Input	Port 4: An 8-bit input port.
	P77 to P70	I/O	Port 7: An 8-bit I/O port. Input or output can be designated for each bit by means of the port 7 data direction register (P7DDR).
	P97 to P90	Input	Port 9: An 8-bit input port.
	PA3 to PA0	I/O	Port A: A 4-bit I/O port. Input or output can be designated for each bit by means of the port A data direction register (PADDR).
	PB7 to PB0	I/O	Port B: An 8-bit I/O port. Input or output can be designated for each bit by means of the port B data direction register (PBDDR).
	PC7 to PC0	I/O	Port C: An 8-bit I/O port. Input or output can be designated for each bit by means of the port C data direction register (PCDDR).
	PD7 to PD0	I/O	Port D: An 8-bit I/O port. Input or output can be designated for each bit by means of the port D data direction register (PDDDR).
	PE7 to PE0	I/O	Port E: An 8-bit I/O port. Input or output can be designated for each bit by means of the port E data direction register (PEDDR).
PF7 to PF0	I/O	Port F: An 8-bit I/O port. Input or output can be designated for each bit by means of the port F data direction register (PFDDR).	
PG4 to PG0	I/O	Port G: An 5-bit I/O port. Input or output can be designated for each bit by means of the port G data direction register (PGDDR).	

**Table 1-3 (b) Pin Functions (H8S/2633R)**

Type	Symbol	I/O	Name and Function
Power	VCL	Output	On-chip power supply stabilizer pin: The VCL pin need not be connected to the power supply. Connect this pin to VSS via a 0.1 $\mu$ F capacitor (placed close to the pins).
	PVCC1, PVCC2	Input	Port power supply pin. Connect all pins to the same power supply.
	VSS	Input	Ground: For connection to ground (0 V). All VSS pins should be connected to the system power supply (0 V).
Clock	PLLVSS	Input	PLL ground: Ground for on-chip PLL oscillator.
	PLLCAP	Input	PLL capacitance: External capacitance pin for on-chip PLL oscillator.
	XTAL	Input	Connects to a crystal oscillator. See section 23B, Clock Pulse Generator (H8S/2633R, H8S/2695), for typical connection diagrams for a crystal oscillator and external clock input.
	EXTAL	Input	Connects to a crystal oscillator. The EXTAL pin can also input an external clock. See section 23B, Clock Pulse Generator (H8S/2633R, H8S/2695), for typical connection diagrams for a crystal oscillator and external clock input.
	OSC1	Input	Subclock: Connects to a 32.768 kHz crystal oscillator. See section 23B, Clock Pulse Generator (H8S/2633R, H8S/2695), for examples of connections to a crystal oscillator.
	OSC2	Input	Subclock: Connects to a 32.768 kHz crystal oscillator. See section 23B, Clock Pulse Generator (H8S/2633R, H8S/2695), for examples of connections to a crystal oscillator.
	$\emptyset$	Output	System clock: Supplies the system clock to an external device.

Type	Symbol	I/O	Name and Function			
Operating mode control	MD2 to MD0	Input	Mode pins: These pins set the operating mode. The relation between the settings of pins MD2 to MD0 and the operating mode is shown below. These pins should not be changed while the H8S/2633 Series is operating.			
			<b>MD2</b>	<b>MD1</b>	<b>MD0</b>	<b>Operating Mode</b>
			0	0	0	—
					1	—
				1	0	—
					1	—
			1	0	0	Mode 4
					1	Mode 5
				1	0	Mode 6
					1	Mode 7
System control	$\overline{\text{RES}}$	Input	Reset input: When this pin is driven low, the chip is reset.			
	$\overline{\text{MRES}}$	Input	Manual reset: When this pin is driven low, a transmission is made to manual reset mode.			
	$\overline{\text{STBY}}$	Input	Standby: When this pin is driven low, a transition is made to hardware standby mode.			
	$\overline{\text{BREQ}}$	Input	Bus request: Used by an external bus master to issue a bus request to the H8S/2633 Series.			
	$\overline{\text{BREQO}}$	Output	Bus request output: The external bus request signal used when an internal bus master accesses external space in the external bus-released state.			
	$\overline{\text{BACK}}$	Output	Bus request acknowledge: Indicates that the bus has been released to an external bus master.			
	FWE	Input	Flash write enable: Pin for flash memory use (in planning stage).			

Type	Symbol	I/O	Name and Function
Interrupts	NMI	Input	Nonmaskable interrupt: Requests a nonmaskable interrupt. When this pin is not used, it should be fixed high.
	$\overline{\text{IRQ7}}$ to $\overline{\text{IRQ0}}$	Input	Interrupt request 7 to 0: These pins request a maskable interrupt.
Address bus	A23 to A0	Output	Address bus: These pins output an address.
Data bus	D15 to D0	I/O	Data bus: These pins constitute a bidirectional data bus.
Bus control	$\overline{\text{CS7}}$ to $\overline{\text{CS0}}$	Output	Chip select: Selection signal for areas 0 to 7.
	$\overline{\text{AS}}$	Output	Address strobe: When this pin is low, it indicates that address output on the address bus is enabled.
	$\overline{\text{RD}}$	Output	Read: When this pin is low, it indicates that the external address space can be read.
	$\overline{\text{HWR}}$	Output	High write/write enable/upper write enable: A strobe signal that writes to external space and indicates that the upper half (D15 to D8) of the data bus is enabled. The 2CAS type DRAM write enable signal. The 2WE type DRAM upper write enable signal.
	$\overline{\text{LWR}}$	Output	Low write/lower column address strobe/lower write enable: A strobe signal that writes to external space and indicates that the lower half (D7 to D0) of the data bus is enabled. The 2CAS type (LCASS = 1) DRAM lower column address strobe signal. The 2WE type DRAM lower write enable signal.
	$\overline{\text{CAS}}$	Output	Upper column address strobe/column address strobe: The 2CAS type DRAM upper column address strobe signal.
	$\overline{\text{LCAS}}$	Output	Lower column address strobe: The 2CAS type DRAM lower column address strobe signal.
	$\overline{\text{OE}}$	Output	Output enable: Output enable signal for DRAM space read access.
	$\overline{\text{WAIT}}$	Input	Wait: Requests insertion of a wait state in the bus cycle when accessing external 3-state address space.

Type	Symbol	I/O	Name and Function
DMA controller (DMAC)	DREQ1, DREQ0	Input	DMA request 1,0: Requests DMAC activation.
	TEND1, TEND0	Output	DMA transfer completed 1,0: Indicates DMAC data transfer end.
	DACK1, DACK0	Output	DMA transfer acknowledge 1,0: DMAC single address transfer acknowledge pin.
16-bit timer-pulse unit (TPU)	TCLKD to TCLKA	Input	Clock input D to A: These pins input an external clock.
	TIOCA0, TIOCB0, TIOCC0, TIOCD0	I/O	Input capture/ output compare match A0 to D0: The TGR0A to TGR0D input capture input or output compare output, or PWM output pins.
	TIOCA1, TIOCB1	I/O	Input capture/ output compare match A1 and B1: The TGR1A and TGR1B input capture input or output compare output, or PWM output pins.
	TIOCA2, TIOCB2	I/O	Input capture/ output compare match A2 and B2: The TGR2A and TGR2B input capture input or output compare output, or PWM output pins.
	TIOCA3, TIOCB3, TIOCC3, TIOCD3	I/O	Input capture/ output compare match A3 to D3: The TGR3A to TGR3D input capture input or output compare output, or PWM output pins.
	TIOCA4, TIOCB4	I/O	Input capture/output compare match A4 and B4: The TGR4A and TGR4B input capture input or output compare output, or PWM output pins.
	TIOCA5, TIOCB5	I/O	Input capture/output compare match A5 and B5: The TGR5A and TGR5B input capture input or output compare output, or PWM output pins.
Programmable pulse generator (PPG)	PO15 to PO8	Output	Pulse output 15 to 8: Pulse output pins.
8-bit timer	TMO0 to TMO3	Output	Compare match output: The compare match output pins.
	TMCI01, TMCI23	Input	Counter external clock input: Input pins for the external clock input to the counter.
	TMRI01, TMRI23	Input	Counter external reset input: The counter reset input pins.

Type	Symbol	I/O	Name and Function
14-bit PWM timer (PWMX)	PWM0 to PWM3	Output	PWMX timer output: PWM D/A pulse output pins.
Watchdog timer (WDT)	$\overline{\text{WDTOVF}}$	Output	Watchdog timer overflows: The counter overflows signal output pin in watchdog timer mode.
	BUZZ	Output	BUZZ output: Output pins for the pulse divided by the watchdog timer.
Serial communication interface (SCI)/ Smart Card interface	TxD4, TxD3, TxD2, TxD1, TxD0	Output	Transmit data (channel 0, 1, 2): Data output pins.
	RxD4, RxD3, RxD2, RxD1, RxD0	Input	Receive data (channel 0, 1, 2): Data input pins.
	SCK4, SCK3, SCK2, SCK1, SCK0	I/O	Serial clock (channel 0, 1, 2): Clock I/O pins. SCK0 output type is NMOS push-pull.
IrDA-equipped SCI 1 channel (SCI0)	IrTxD IrRxD	Output/ Input	IrDA transmission data/receive data: Input/output pins for the data encoded for the IrDA.
I <sup>2</sup> C bus interface (IIC)	SCL0 SCL1	I/O	I <sup>2</sup> C clock input (channel 1, 0): I <sup>2</sup> C clock input/output pins. These functions have a bus driving function. SCL0's output format is an NMOS open drain.
	SDA0 SDA1	I/O	I <sup>2</sup> C data input/output (channel 1, 0): I <sup>2</sup> C clock input/output pins. These functions have a bus driving function. SCL0's output format is an NMOS open drain.
A/D converter	AN15 to AN0	Input	Analog 15 to 0: Analog input pins.
	$\overline{\text{ADTRG}}$	Input	A/D conversion external trigger input: Pin for input of an external trigger to start A/D conversion.
D/A converter	DA3 to DA0	Output	Analog output: Analog output pins for D/A converter.
A/D converter, D/A converter	AVCC	Input	A/D converter and D/A converter power supply pin. When the A/D converter and D/A converter are not used, this pin should be connected to the system power supply (+5 V).

Type	Symbol	I/O	Name and Function
A/D converter, D/A converter	AVSS	Input	Analog circuit ground and reference voltage A/D converter and D/A converter ground and reference voltage. Connect to system power supply (0 V).
	Vref	Input	A/D converter and D/A converter reference voltage input pin. When the A/D converter and D/A converter are not used, this pin should be connected to the system power supply (+5 V).
I/O ports	P17 to P10	I/O	Port 1: An 8-bit I/O port. Input or output can be designated for each bit by means of the port 1 data direction register (P1DDR).
	P37 to P30	I/O	Port 3: An 8-bit I/O port. Input or output can be designated for each bit by means of the port 3 data direction register (P3DDR).
	P47 to P40	Input	Port 4: An 8-bit input port.
	P77 to P70	I/O	Port 7: An 8-bit I/O port. Input or output can be designated for each bit by means of the port 7 data direction register (P7DDR).
	P97 to P90	Input	Port 9: An 8-bit input port.
	PA3 to PA0	I/O	Port A: A 4-bit I/O port. Input or output can be designated for each bit by means of the port A data direction register (PADDR).
	PB7 to PB0	I/O	Port B: An 8-bit I/O port. Input or output can be designated for each bit by means of the port B data direction register (PBDDR).
	PC7 to PC0	I/O	Port C: An 8-bit I/O port. Input or output can be designated for each bit by means of the port C data direction register (PCDDR).
	PD7 to PD0	I/O	Port D: An 8-bit I/O port. Input or output can be designated for each bit by means of the port D data direction register (PDDDR).
	PE7 to PE0	I/O	Port E: An 8-bit I/O port. Input or output can be designated for each bit by means of the port E data direction register (PEDDR).
PF7 to PF0	I/O	Port F: An 8-bit I/O port. Input or output can be designated for each bit by means of the port F data direction register (PFDDR).	
PG4 to PG0	I/O	Port G: An 5-bit I/O port. Input or output can be designated for each bit by means of the port G data direction register (PGDDR).	



**Table 1-3 (c) Pin Functions (H8S/2695)**

Type	Symbol	I/O	Name and Function																							
Power	VCL	Output	On-chip power supply stabilizer pin: The VCL pin need not be connected to the power supply. Connect this pin to VSS via a 0.1 $\mu$ F capacitor (placed close to the pins).																							
	PVCC	Input	Port power supply pin. Connect all pins to the same power supply.																							
	VSS	Input	Ground: For connection to ground (0 V). All VSS pins should be connected to the system power supply (0 V).																							
Clock	PLLVSS	Input	PLL ground: Ground for on-chip PLL oscillator.																							
	PLLCAP	Input	PLL capacitance: External capacitance pin for on-chip PLL oscillator.																							
	XTAL	Input	Connects to a crystal oscillator. See section 23B, Clock Pulse Generator (H8S/2633R, H8S/2695), for typical connection diagrams for a crystal oscillator and external clock input.																							
	EXTAL	Input	Connects to a crystal oscillator. The EXTAL pin can also input an external clock. See section 23B, Clock Pulse Generator (H8S/2633R, H8S/2695), for typical connection diagrams for a crystal oscillator and external clock input.																							
	$\emptyset$	Output	System clock: Supplies the system clock to an external device.																							
Operating mode control	MD2 to MD0	Input	Mode pins: These pins set the operating mode. The relation between the settings of pins MD2 to MD0 and the operating mode is shown below. These pins should not be changed while the H8S/2633 Series is operating.																							
			<table border="1"> <thead> <tr> <th>MD2</th> <th>MD1</th> <th>MD0</th> <th>Operating Mode</th> </tr> </thead> <tbody> <tr> <td rowspan="4">0</td> <td rowspan="2">0</td> <td>0</td> <td>—</td> </tr> <tr> <td>1</td> <td>—</td> </tr> <tr> <td rowspan="2">1</td> <td>0</td> <td>—</td> </tr> <tr> <td>1</td> <td>—</td> </tr> <tr> <td rowspan="4">1</td> <td rowspan="2">0</td> <td>0</td> <td>Mode 4</td> </tr> <tr> <td>1</td> <td>Mode 5</td> </tr> <tr> <td rowspan="2">1</td> <td>0</td> <td>Mode 6</td> </tr> <tr> <td>1</td> <td>Mode 7</td> </tr> </tbody> </table>	MD2	MD1	MD0	Operating Mode	0	0	0	—	1	—	1	0	—	1	—	1	0	0	Mode 4	1	Mode 5	1	0
MD2	MD1	MD0	Operating Mode																							
0	0	0	—																							
		1	—																							
	1	0	—																							
		1	—																							
1	0	0	Mode 4																							
		1	Mode 5																							
	1	0	Mode 6																							
		1	Mode 7																							

Type	Symbol	I/O	Name and Function
System control	$\overline{\text{RES}}$	Input	Reset input: When this pin is driven low, the chip is reset.
	$\overline{\text{MRES}}$	Input	Manual reset: When this pin is driven low, a transmission is made to manual reset mode.
	$\overline{\text{STBY}}$	Input	Standby: When this pin is driven low, a transition is made to hardware standby mode.
	$\overline{\text{BREQ}}$	Input	Bus request: Used by an external bus master to issue a bus request to the H8S/2633 Series.
	$\overline{\text{BREQO}}$	Output	Bus request output: The external bus request signal used when an internal bus master accesses external space in the external bus-released state.
	$\overline{\text{BACK}}$	Output	Bus request acknowledge: Indicates that the bus has been released to an external bus master.
Interrupts	NMI	Input	Nonmaskable interrupt: Requests a nonmaskable interrupt. When this pin is not used, it should be fixed high.
	$\overline{\text{IRQ7}}$ to $\overline{\text{IRQ0}}$	Input	Interrupt request 7 to 0: These pins request a maskable interrupt.
Address bus	A23 to A0	Output	Address bus: These pins output an address.
Data bus	D15 to D0	I/O	Data bus: These pins constitute a bidirectional data bus.
Bus control	$\overline{\text{CS7}}$ to $\overline{\text{CS0}}$	Output	Chip select: Selection signal for areas 0 to 7.
	$\overline{\text{AS}}$	Output	Address strobe: When this pin is low, it indicates that address output on the address bus is enabled.
	$\overline{\text{RD}}$	Output	Read: When this pin is low, it indicates that the external address space can be read.
	$\overline{\text{HWR}}$	Output	High write/write enable/upper write enable: A strobe signal that writes to external space and indicates that the upper half (D15 to D8) of the data bus is enabled. The 2CAS type DRAM write enable signal. The 2WE type DRAM upper write enable signal.
	$\overline{\text{LWR}}$	Output	Low write/lower column address strobe/lower write enable: A strobe signal that writes to external space and indicates that the lower half (D7 to D0) of the data bus is enabled. The 2CAS type (LCASS = 1) DRAM lower column address strobe signal. The 2WE type DRAM lower write enable signal.
	$\overline{\text{WAIT}}$	Input	Wait: Requests insertion of a wait state in the bus cycle when accessing external 3-state address space.

Type	Symbol	I/O	Name and Function
16-bit timer-pulse unit (TPU)	TCLKD to TCLKA	Input	Clock input D to A: These pins input an external clock.
	TIOCA0, TIOCB0, TIOCC0, TIOCD0	I/O	Input capture/ output compare match A0 to D0: The TGR0A to TGR0D input capture input or output compare output, or PWM output pins.
	TIOCA1, TIOCB1	I/O	Input capture/ output compare match A1 and B1: The TGR1A and TGR1B input capture input or output compare output, or PWM output pins.
	TIOCA2, TIOCB2	I/O	Input capture/ output compare match A2 and B2: The TGR2A and TGR2B input capture input or output compare output, or PWM output pins.
	TIOCA3, TIOCB3, TIOCC3, TIOCD3	I/O	Input capture/ output compare match A3 to D3: The TGR3A to TGR3D input capture input or output compare output, or PWM output pins.
	TIOCA4, TIOCB4	I/O	Input capture/output compare match A4 and B4: The TGR4A and TGR4B input capture input or output compare output, or PWM output pins.
	TIOCA5, TIOCB5	I/O	Input capture/output compare match A5 and B5: The TGR5A and TGR5B input capture input or output compare output, or PWM output pins.
Watchdog timer (WDT)	WDTOVF	Output	Watchdog timer overflows: The counter overflows signal output pin in watchdog timer mode.
Serial communication interface (SCI)/ Smart Card interface	TxD4, TxD3, TxD2, TxD1, TxD0	Output	Transmit data (channel 0, 1, 2): Data output pins.
	RxD4, RxD3, RxD2, RxD1, RxD0	Input	Receive data (channel 0, 1, 2): Data input pins.
	SCK4, SCK3, SCK2, SCK1, SCK0	I/O	Serial clock (channel 0, 1, 2): Clock I/O pins. SCK0 output type is NMOS push-pull.

Type	Symbol	I/O	Name and Function
A/D converter	AN15 to AN0	Input	Analog 15 to 0: Analog input pins.
	$\overline{\text{ADTRG}}$	Input	A/D conversion external trigger input: Pin for input of an external trigger to start A/D conversion.
	AVCC	Input	A/D converter power supply pin. When the A/D converter are not used, this pin should be connected to the system power supply (+5 V).
	AVSS	Input	Analog circuit ground and reference voltage A/D converter ground and reference voltage. Connect to system power supply (0 V).
	Vref	Input	A/D converter reference voltage input pin. When the A/D converter are not used, this pin should be connected to the system power supply (+5 V).
I/O ports	P17 to P10	I/O	Port 1: An 8-bit I/O port. Input or output can be designated for each bit by means of the port 1 data direction register (P1DDR).
	P37 to P30	I/O	Port 3: An 8-bit I/O port. Input or output can be designated for each bit by means of the port 3 data direction register (P3DDR).
	P47 to P40	Input	Port 4: An 8-bit input port.
	P77 to P70	I/O	Port 7: An 8-bit I/O port. Input or output can be designated for each bit by means of the port 7 data direction register (P7DDR).
	P97 to P90	Input	Port 9: An 8-bit input port.
	PA3 to PA0	I/O	Port A: A 4-bit I/O port. Input or output can be designated for each bit by means of the port A data direction register (PADDDR).
	PB7 to PB0	I/O	Port B: An 8-bit I/O port. Input or output can be designated for each bit by means of the port B data direction register (PBDDR).
	PC7 to PC0	I/O	Port C: An 8-bit I/O port. Input or output can be designated for each bit by means of the port C data direction register (PCDDR).
	PD7 to PD0	I/O	Port D: An 8-bit I/O port. Input or output can be designated for each bit by means of the port D data direction register (PDDDR).

<b>Type</b>	<b>Symbol</b>	<b>I/O</b>	<b>Name and Function</b>
I/O ports	PE7 to PE0	I/O	Port E: An 8-bit I/O port. Input or output can be designated for each bit by means of the port E data direction register (PEDDR).
	PF7 to PF0	I/O	Port F: An 8-bit I/O port. Input or output can be designated for each bit by means of the port F data direction register (PFDDR).
	PG4 to PG0	I/O	Port G: An 5-bit I/O port. Input or output can be designated for each bit by means of the port G data direction register (PGDDR).



## Section 2 CPU

### 2.1 Overview

The H8S/2600 CPU is a high-speed central processing unit with an internal 32-bit architecture that is upward-compatible with the H8/300 and H8/300H CPUs. The H8S/2600 CPU has sixteen 16-bit general registers, can address a 16-Mbyte (architecturally 4-Gbyte) linear address space, and is ideal for realtime control.

#### 2.1.1 Features

The H8S/2600 CPU has the following features.

- Upward-compatible with H8/300 and H8/300H CPUs
  - Can execute H8/300 and H8/300H object programs
- General-register architecture
  - Sixteen 16-bit general registers (also usable as sixteen 8-bit registers or eight 32-bit registers)
- Sixty-nine basic instructions
  - 8/16/32-bit arithmetic and logic instructions
  - Multiply and divide instructions
  - Powerful bit-manipulation instructions
  - Multiply-and-accumulate instruction
- Eight addressing modes
  - Register direct [Rn]
  - Register indirect [@ERn]
  - Register indirect with displacement [@(d:16,ERn) or @(d:32,ERn)]
  - Register indirect with post-increment or pre-decrement [@ERn+ or @-ERn]
  - Absolute address [@aa:8, @aa:16, @aa:24, or @aa:32]
  - Immediate [#xx:8, #xx:16, or #xx:32]
  - Program-counter relative [@(d:8,PC) or @(d:16,PC)]
  - Memory indirect [@@aa:8]
- 16-Mbyte address space
  - Program: 16 Mbytes
  - Data: 16 Mbytes (4 Gbytes architecturally)

- High-speed operation
  - All frequently-used instructions execute in one or two states
  - Maximum clock rate : 25 MHz (H8S/2633, H8S/2632, H8S/2631, H8S/2633F), 28 MHz (H8S/2633R, H8S/2695)
  - 8/16/32-bit register-register add/subtract : 40 ns (25 MHz), 35 ns (28 MHz)
  - 8 × 8-bit register-register multiply : 120 ns (25 MHz), 105 ns (28 MHz)
  - 16 ÷ 8-bit register-register divide : 480 ns (25 MHz), 420 ns (28 MHz)
  - 16 × 16-bit register-register multiply : 160 ns (25 MHz), 140 ns (28 MHz)
  - 32 ÷ 16-bit register-register divide : 800 ns (25 MHz), 700 ns (28 MHz)
- Two CPU operating modes
  - Normal mode\*
  - Advanced mode

Note: \* Not available in the H8S/2633 Series.

- Power-down state
  - Transition to power-down state by SLEEP instruction
  - CPU clock speed selection

### 2.1.2 Differences between H8S/2600 CPU and H8S/2000 CPU

The differences between the H8S/2600 CPU and the H8S/2000 CPU are as shown below.

- Register configuration
  - The MAC register is supported only by the H8S/2600 CPU.
- Basic instructions
  - The four instructions MAC, CLRMAC, LDMAC, and STMAC are supported only by the H8S/2600 CPU.
- Number of execution states
  - The number of execution states of the MULXU and MULXS instructions is different in each CPU.



Instruction	Mnemonic	Execution States	
		H8S/2600	H8S/2000
MULXU	MULXU.B Rs, Rd	3	12
	MULXU.W Rs, ERd	4	20
MULXS	MULXS.B Rs, Rd	4	13
	MULXS.W Rs, ERd	5	21

In addition, there are differences in address space, CCR and EXR register functions, power-down modes, etc., depending on the model.

### 2.1.3 Differences from H8/300 CPU

In comparison to the H8/300 CPU, the H8S/2600 CPU has the following enhancements.

- More general registers and control registers
  - Eight 16-bit expanded registers, and one 8-bit and two 32-bit control registers, have been added.
- Expanded address space
  - Normal mode\* supports the same 64-kbyte address space as the H8/300 CPU.
  - Advanced mode supports a maximum 16-Mbyte address space.

Note: \* Not available in the H8S/2633 Series.

- Enhanced addressing
  - The addressing modes have been enhanced to make effective use of the 16-Mbyte address space.
- Enhanced instructions
  - Addressing modes of bit-manipulation instructions have been enhanced.
  - Signed multiply and divide instructions have been added.
  - A multiply-and-accumulate instruction has been added.
  - Two-bit shift instructions have been added.
  - Instructions for saving and restoring multiple registers have been added.
  - A test and set instruction has been added.
- Higher speed
  - Basic instructions execute twice as fast.

### 2.1.4 Differences from H8/300H CPU

In comparison to the H8/300H CPU, the H8S/2600 CPU has the following enhancements.

- Additional control register
  - One 8-bit and two 32-bit control registers have been added
- Enhanced instructions
  - Addressing modes of bit-manipulation instructions have been enhanced
  - A multiply-and-accumulate instruction has been added
  - Two-bit shift instructions have been added
  - Instructions for saving and restoring multiple registers have been added
  - A test and set instruction has been added
- Higher speed
  - Basic instructions execute twice as fast

## 2.2 CPU Operating Modes

The H8S/2600 CPU has two operating modes: normal and advanced. Normal mode\* supports a maximum 64-kbyte address space. Advanced mode supports a maximum 16-Mbyte total address space (architecturally a maximum 16-Mbyte program area and a maximum of 4 Gbytes for program and data areas combined). The mode is selected by the mode pins of the microcontroller.

Note: \* Not available in the H8S/2633 Series.

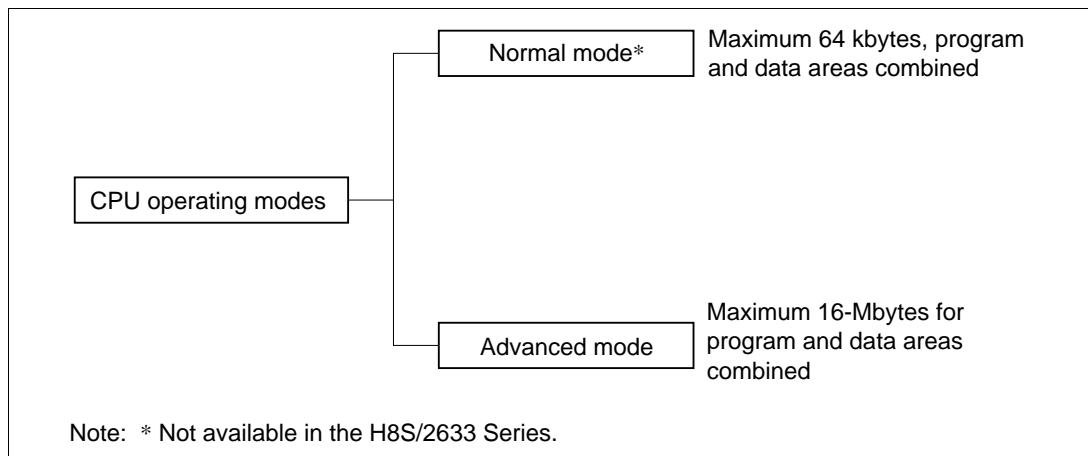


Figure 2-1 CPU Operating Modes

**(1) Normal Mode (Not Available in the H8S/2633 Series)**

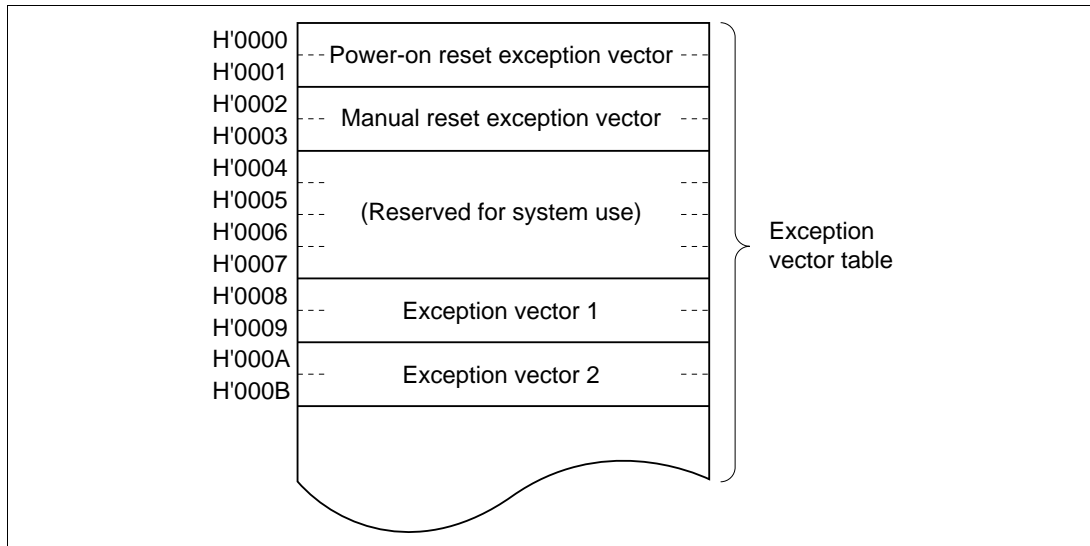
The exception vector table and stack have the same structure as in the H8/300 CPU.

**Address Space:** A maximum address space of 64 kbytes can be accessed.

**Extended Registers (En):** The extended registers (E0 to E7) can be used as 16-bit registers, or as the upper 16-bit segments of 32-bit registers. When En is used as a 16-bit register it can contain any value, even when the corresponding general register (Rn) is used as an address register. If the general register is referenced in the register indirect addressing mode with pre-decrement (@-Rn) or post-increment (@Rn+) and a carry or borrow occurs, however, the value in the corresponding extended register (En) will be affected.

**Instruction Set:** All instructions and addressing modes can be used. Only the lower 16 bits of effective addresses (EA) are valid.

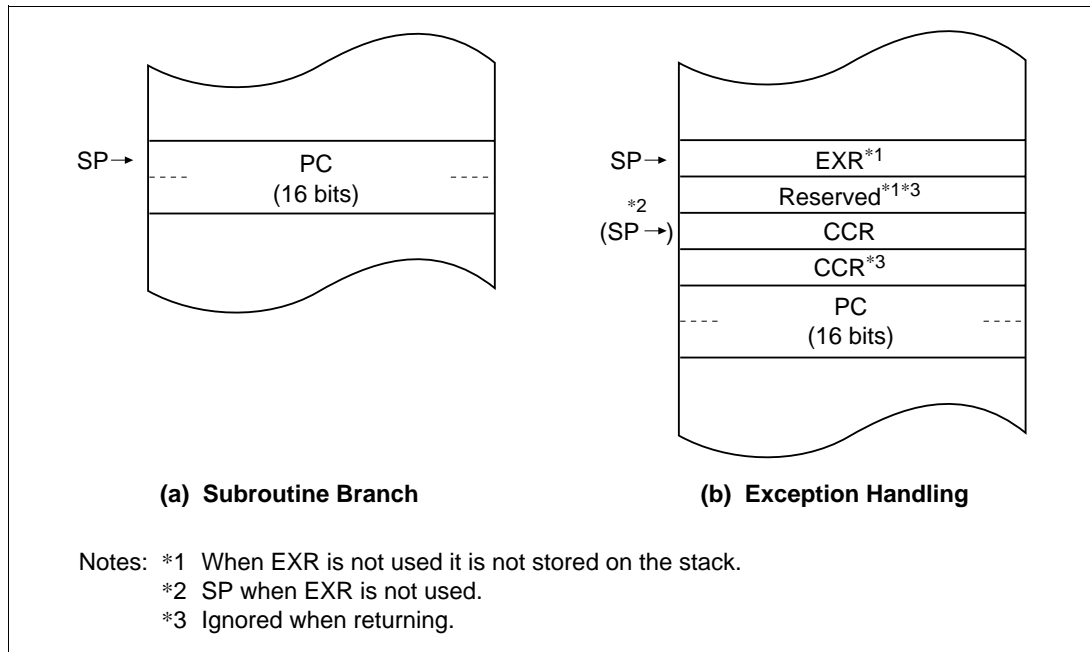
**Exception Vector Table and Memory Indirect Branch Addresses:** In normal mode the top area starting at H'0000 is allocated to the exception vector table. One branch address is stored per 16 bits (figure 2-2). The exception vector table differs depending on the microcontroller. For details of the exception vector table, see section 4, Exception Handling.



**Figure 2-2 Exception Vector Table (Normal Mode)**

The memory indirect addressing mode (@@aa:8) employed in the JMP and JSR instructions uses an 8-bit absolute address included in the instruction code to specify a memory operand that contains a branch address. In normal mode the operand is a 16-bit word operand, providing a 16-bit branch address. Branch addresses can be stored in the top area from H'0000 to H'00FF. Note that this area is also used for the exception vector table.

**Stack Structure:** When the program counter (PC) is pushed onto the stack in a subroutine call, and the PC, condition-code register (CCR), and extended control register (EXR) are pushed onto the stack in exception handling, they are stored as shown in figure 2-3. When EXR is invalid, it is not pushed onto the stack. For details, see section 4, Exception Handling.



**Figure 2-3 Stack Structure in Normal Mode**

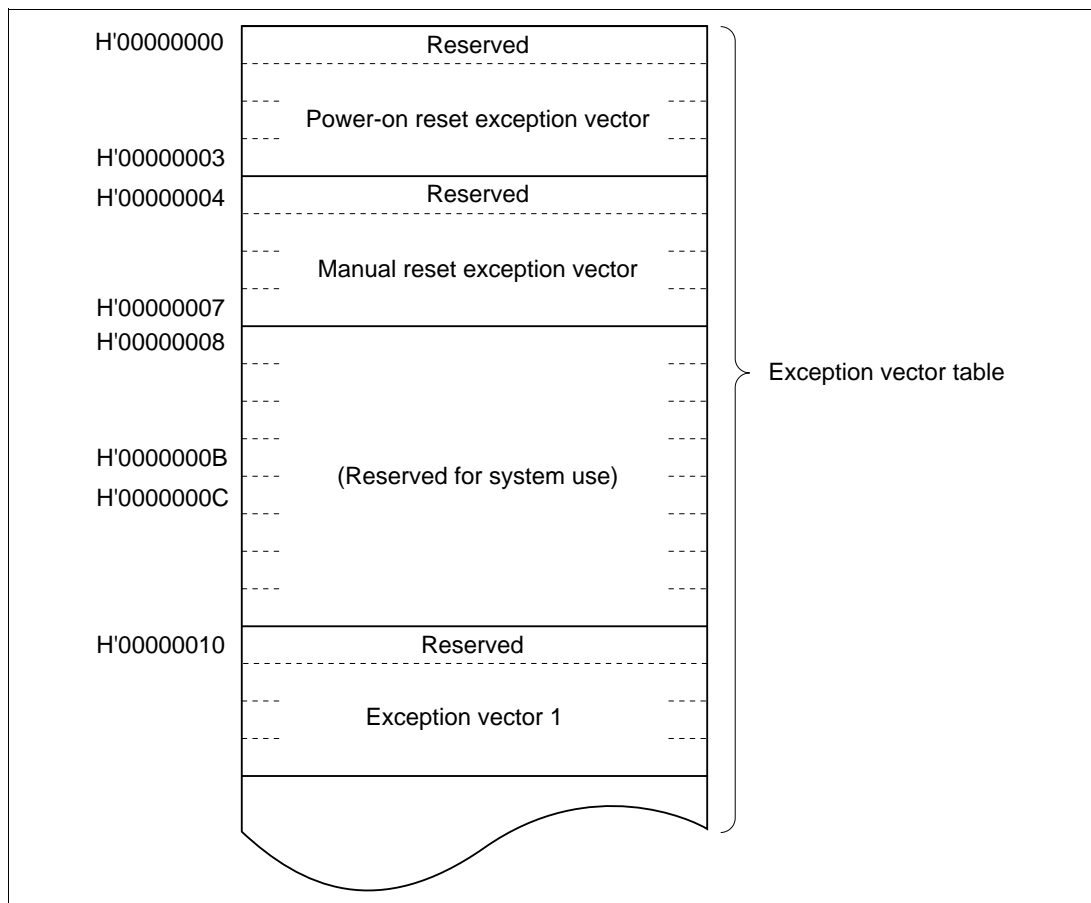
**(2) Advanced Mode**

**Address Space:** Linear access is provided to a 16-Mbyte maximum address space (architecturally a maximum 16-Mbyte program area and a maximum 4-Gbyte data area, with a maximum of 4 Gbytes for program and data areas combined).

**Extended Registers (En):** The extended registers (E0 to E7) can be used as 16-bit registers, or as the upper 16-bit segments of 32-bit registers or address registers.

**Instruction Set:** All instructions and addressing modes can be used.

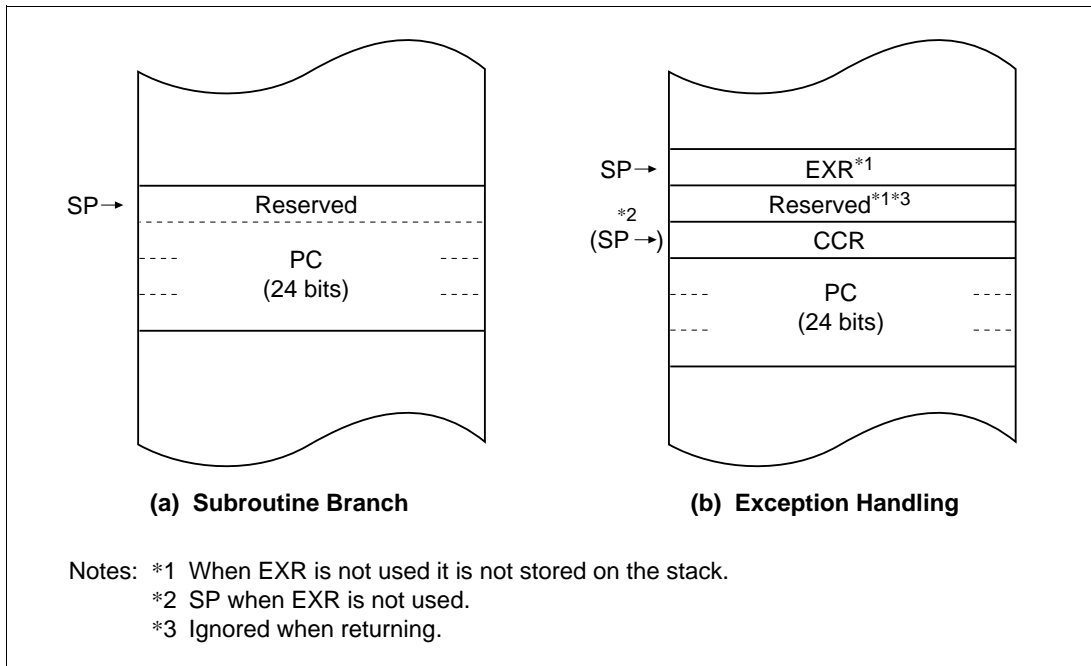
**Exception Vector Table and Memory Indirect Branch Addresses:** In advanced mode the top area starting at H'00000000 is allocated to the exception vector table in units of 32 bits. In each 32 bits, the upper 8 bits are ignored and a branch address is stored in the lower 24 bits (figure 2-4). For details of the exception vector table, see section 4, Exception Handling.



**Figure 2-4 Exception Vector Table (Advanced Mode)**

The memory indirect addressing mode (@@aa:8) employed in the JMP and JSR instructions uses an 8-bit absolute address included in the instruction code to specify a memory operand that contains a branch address. In advanced mode the operand is a 32-bit longword operand, providing a 32-bit branch address. The upper 8 bits of these 32 bits are a reserved area that is regarded as H'00. Branch addresses can be stored in the area from H'00000000 to H'000000FF. Note that the first part of this range is also the exception vector table.

**Stack Structure:** In advanced mode, when the program counter (PC) is pushed onto the stack in a subroutine call, and the PC, condition-code register (CCR), and extended control register (EXR) are pushed onto the stack in exception handling, they are stored as shown in figure 2-5. When EXR is invalid, it is not pushed onto the stack. For details, see section 4, Exception Handling.



**Figure 2-5 Stack Structure in Advanced Mode**

## 2.3 Address Space

Figure 2-6 shows a memory map of the H8S/2600 CPU. The H8S/2600 CPU provides linear access to a maximum 64-kbyte address space in normal mode, and a maximum 16-Mbyte (architecturally 4-Gbyte) address space in advanced mode.

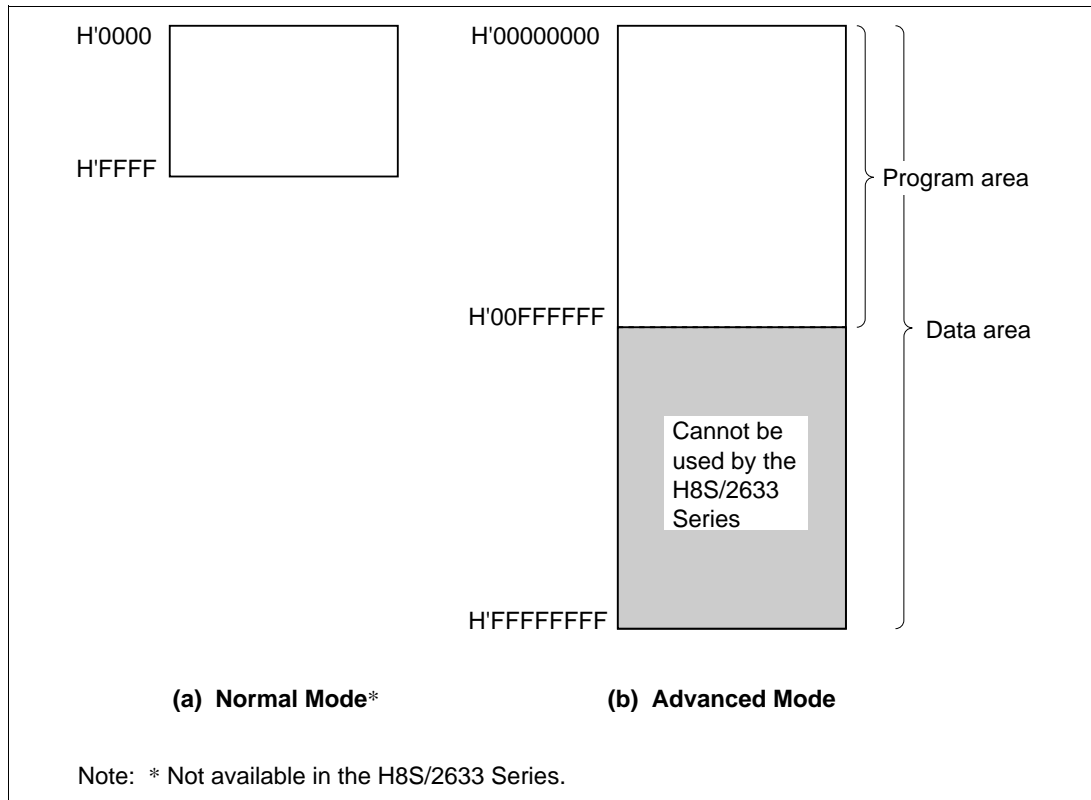


Figure 2-6 Memory Map

## 2.4 Register Configuration

### 2.4.1 Overview

The CPU has the internal registers shown in figure 2-7. There are two types of registers: general registers and control registers.

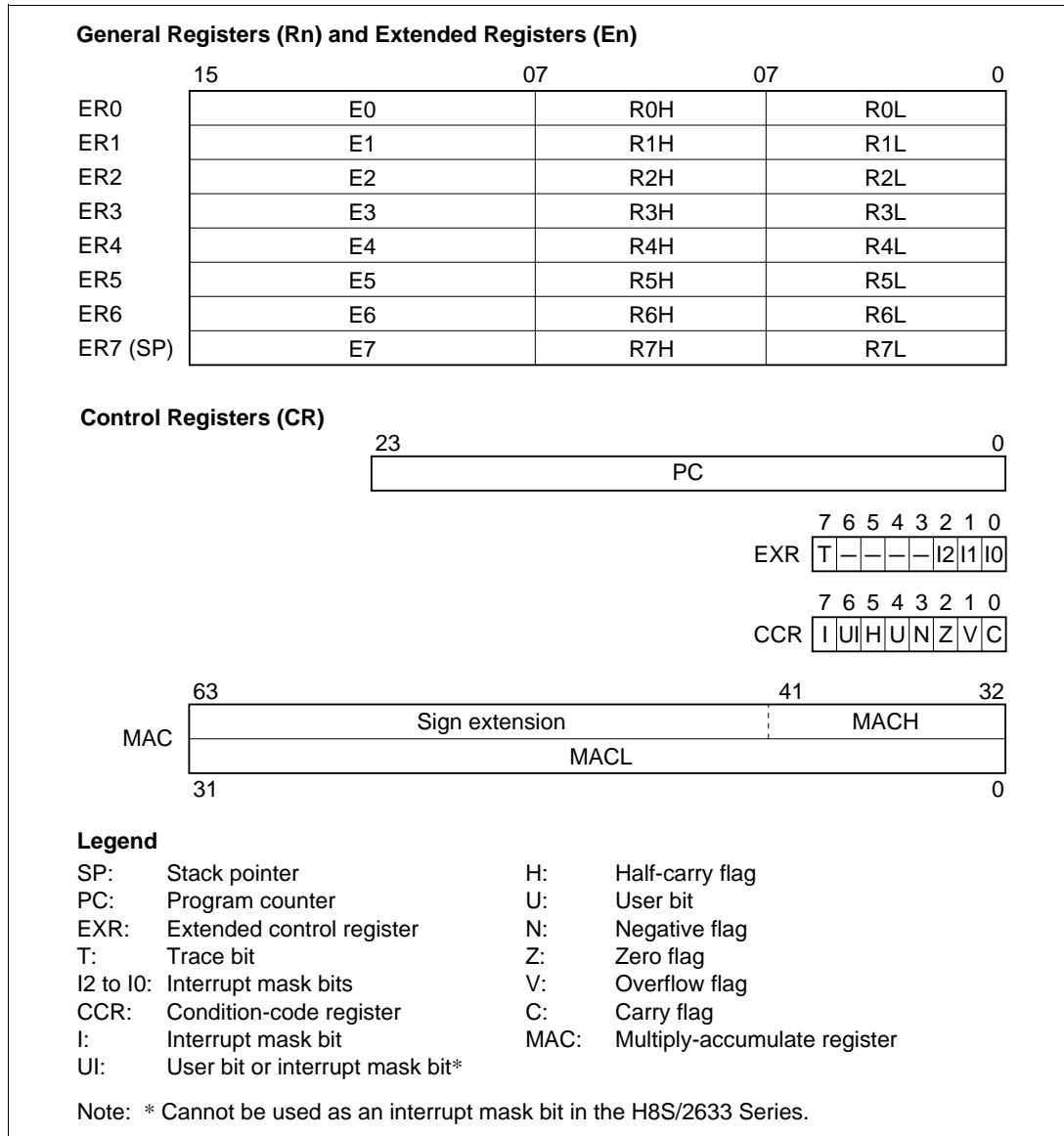


Figure 2-7 CPU Registers



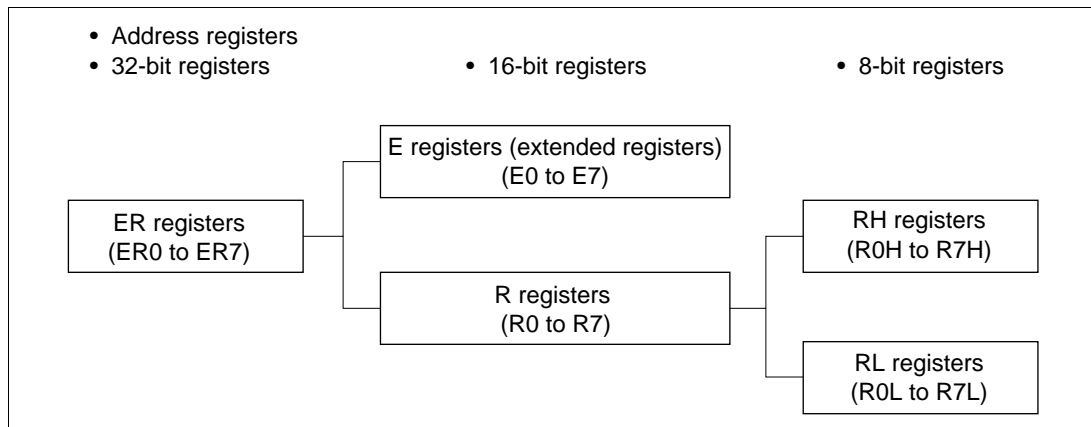
## 2.4.2 General Registers

The CPU has eight 32-bit general registers. These general registers are all functionally alike and can be used as both address registers and data registers. When a general register is used as a data register, it can be accessed as a 32-bit, 16-bit, or 8-bit register. When the general registers are used as 32-bit registers or address registers, they are designated by the letters ER (ER0 to ER7).

The ER registers divide into 16-bit general registers designated by the letters E (E0 to E7) and R (R0 to R7). These registers are functionally equivalent, providing a maximum sixteen 16-bit registers. The E registers (E0 to E7) are also referred to as extended registers.

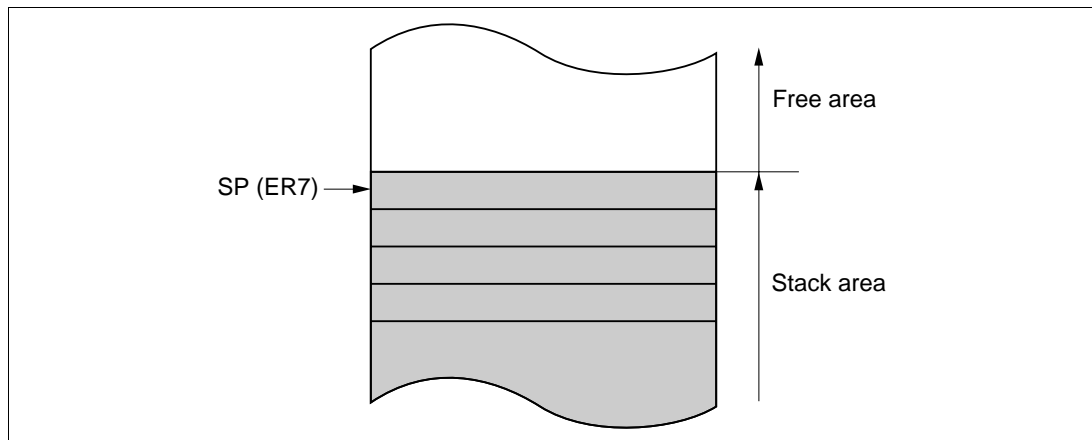
The R registers divide into 8-bit general registers designated by the letters RH (R0H to R7H) and RL (R0L to R7L). These registers are functionally equivalent, providing a maximum sixteen 8-bit registers.

Figure 2-8 illustrates the usage of the general registers. The usage of each register can be selected independently.



**Figure 2-8 Usage of General Registers**

General register ER7 has the function of stack pointer (SP) in addition to its general-register function, and is used implicitly in exception handling and subroutine calls. Figure 2-9 shows the stack.



**Figure 2-9 Stack**

### 2.4.3 Control Registers

The control registers are the 24-bit program counter (PC), 8-bit extended control register (EXR), 8-bit condition-code register (CCR), and 64-bit multiply-accumulate register (MAC).

**(1) Program Counter (PC):** This 24-bit counter indicates the address of the next instruction the CPU will execute. The length of all CPU instructions is 2 bytes (one word), so the least significant PC bit is ignored. (When an instruction is fetched, the least significant PC bit is regarded as 0.)

**(2) Extended Control Register (EXR):** This 8-bit register contains the trace bit (T) and three interrupt mask bits (I2 to I0).

**Bit 7—Trace Bit (T):** Selects trace mode. When this bit is cleared to 0, instructions are executed in sequence. When this bit is set to 1, a trace exception is generated each time an instruction is executed.

**Bits 6 to 3—Reserved:** They are always read as 1.

**Bits 2 to 0—Interrupt Mask Bits (I2 to I0):** These bits designate the interrupt mask level (0 to 7). For details, refer to section 5, Interrupt Controller.

Operations can be performed on the EXR bits by the LDC, STC, ANDC, ORC, and XORC instructions. All interrupts, including NMI, are disabled for three states after one of these instructions is executed, except for STC.

**(3) Condition-Code Register (CCR):** This 8-bit register contains internal CPU status information, including an interrupt mask bit (I) and half-carry (H), negative (N), zero (Z), overflow (V), and carry (C) flags.

**Bit 7—Interrupt Mask Bit (I):** Masks interrupts other than NMI when set to 1. (NMI is accepted regardless of the I bit setting.) The I bit is set to 1 by hardware at the start of an exception-handling sequence. For details, refer to section 5, Interrupt Controller.

**Bit 6—User Bit or Interrupt Mask Bit (UI):** Can be written and read by software using the LDC, STC, ANDC, ORC, and XORC instructions. This bit can also be used as an interrupt mask bit. For details, refer to section 5, Interrupt Controller.

**Bit 5—Half-Carry Flag (H):** When the ADD.B, ADDX.B, SUB.B, SUBX.B, CMP.B, or NEG.B instruction is executed, this flag is set to 1 if there is a carry or borrow at bit 3, and cleared to 0 otherwise. When the ADD.W, SUB.W, CMP.W, or NEG.W instruction is executed, the H flag is set to 1 if there is a carry or borrow at bit 11, and cleared to 0 otherwise. When the ADD.L, SUB.L, CMP.L, or NEG.L instruction is executed, the H flag is set to 1 if there is a carry or borrow at bit 27, and cleared to 0 otherwise.

**Bit 4—User Bit (U):** Can be written and read by software using the LDC, STC, ANDC, ORC, and XORC instructions.

**Bit 3—Negative Flag (N):** Stores the value of the most significant bit (sign bit) of data.

**Bit 2—Zero Flag (Z):** Set to 1 to indicate zero data, and cleared to 0 to indicate non-zero data.

**Bit 1—Overflow Flag (V):** Set to 1 when an arithmetic overflow occurs, and cleared to 0 at other times.

**Bit 0—Carry Flag (C):** Set to 1 when a carry occurs, and cleared to 0 otherwise. Used by:

- Add instructions, to indicate a carry
- Subtract instructions, to indicate a borrow
- Shift and rotate instructions, to store the value shifted out of the end bit

The carry flag is also used as a bit accumulator by bit manipulation instructions.

Some instructions leave some or all of the flag bits unchanged. For the action of each instruction on the flag bits, refer to Appendix A.1, Instruction List.

Operations can be performed on the CCR bits by the LDC, STC, ANDC, ORC, and XORC instructions. The N, Z, V, and C flags are used as branching conditions for conditional branch (Bcc) instructions.

**(4) Multiply-Accumulate Register (MAC):** This 64-bit register stores the results of multiply-and-accumulate operations. It consists of two 32-bit registers denoted MACH and MACL. The lower 10 bits of MACH are valid; the upper bits are a sign extension.

#### 2.4.4 Initial Register Values

Reset exception handling loads the CPU's program counter (PC) from the vector table, clears the trace bit in EXR to 0, and sets the interrupt mask bits in CCR and EXR to 1. The other CCR bits and the general registers are not initialized. In particular, the stack pointer (ER7) is not initialized. The stack pointer should therefore be initialized by an MOV.L instruction executed immediately after a reset.

## 2.5 Data Formats

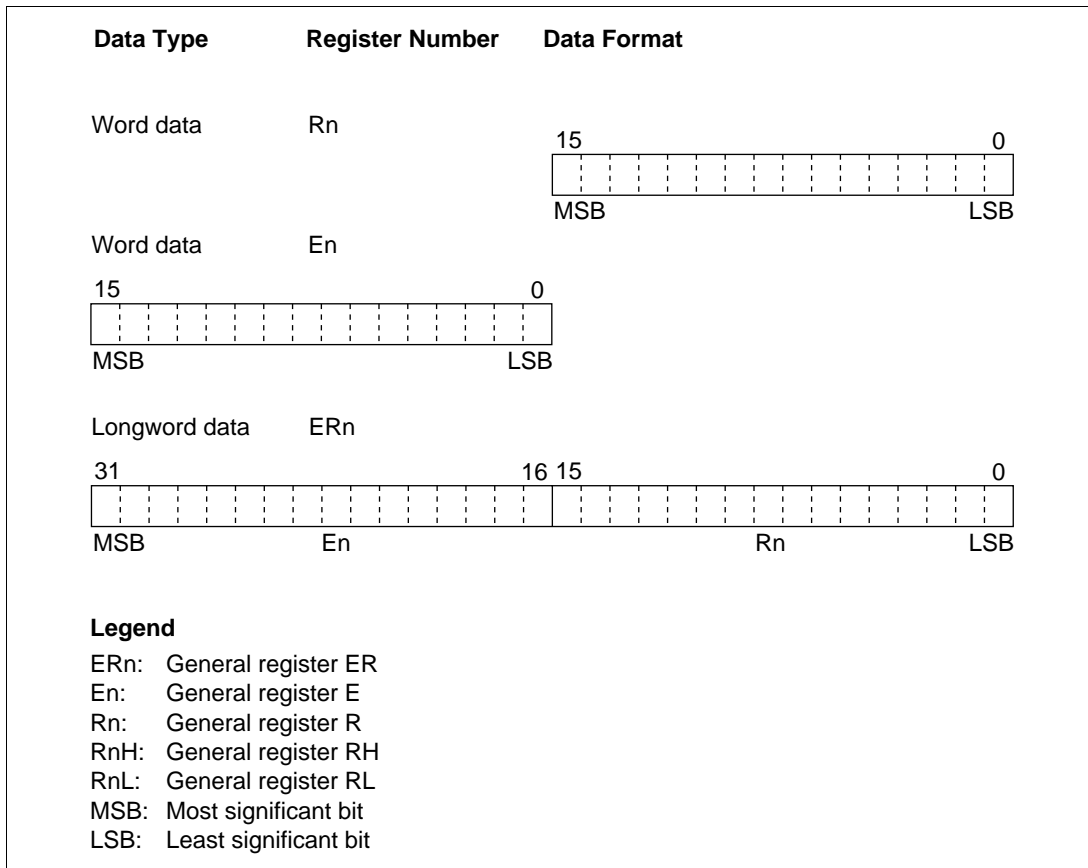
The CPU can process 1-bit, 4-bit (BCD), 8-bit (byte), 16-bit (word), and 32-bit (longword) data. Bit-manipulation instructions operate on 1-bit data by accessing bit  $n$  ( $n = 0, 1, 2, \dots, 7$ ) of byte operand data. The DAA and DAS decimal-adjust instructions treat byte data as two digits of 4-bit BCD data.

### 2.5.1 General Register Data Formats

Figure 2-10 shows the data formats in general registers.

Data Type	Register Number	Data Format
1-bit data	RnH	
1-bit data	RnL	
4-bit BCD data	RnH	
4-bit BCD data	RnL	
Byte data	RnH	
Byte data	RnL	

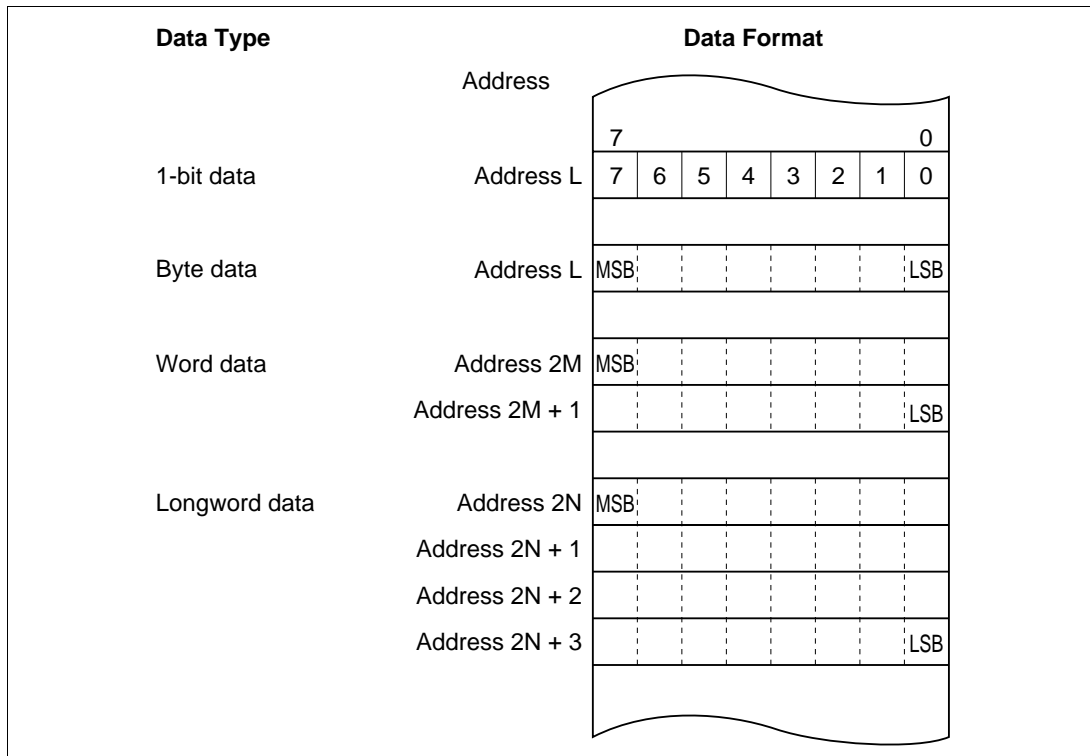
Figure 2-10 General Register Data Formats



**Figure 2-10 General Register Data Formats (cont)**

## 2.5.2 Memory Data Formats

Figure 2-11 shows the data formats in memory. The CPU can access word data and longword data in memory, but word or longword data must begin at an even address. If an attempt is made to access word or longword data at an odd address, no address error occurs but the least significant bit of the address is regarded as 0, so the access starts at the preceding address. This also applies to instruction fetches.



**Figure 2-11 Memory Data Formats**

When ER7 is used as an address register to access the stack, the operand size should be word size or longword size.

## 2.6 Instruction Set

### 2.6.1 Overview

The H8S/2600 CPU has 69 types of instructions. The instructions are classified by function in table 2-1.

**Table 2-1 Instruction Classification**

Function	Instructions	Size	Types
Data transfer	MOV	BWL	5
	POP* <sup>1</sup> , PUSH* <sup>1</sup>	WL	
	LDM, STM	L	
	MOVFPE* <sup>3</sup> , MOVTPPE* <sup>3</sup>	B	
Arithmetic operations	ADD, SUB, CMP, NEG	BWL	23
	ADDX, SUBX, DAA, DAS	B	
	INC, DEC	BWL	
	ADDS, SUBS	L	
	MULXU, DIVXU, MULXS, DIVXS	BW	
	EXTU, EXTS	WL	
	TAS* <sup>4</sup>	B	
	MAC, LDMAC, STMAC, CLRMAC	—	
Logic operations	AND, OR, XOR, NOT	BWL	4
Shift	SHAL, SHAR, SHLL, SHLR, ROTL, ROTR, ROTXL, ROTXR	BWL	8
Bit manipulation	BSET, BCLR, BNOT, BTST, BLD, BILD, BST, BIST, BAND, BIAND, BOR, BIOR, BXOR, BIXOR	B	14
Branch	Bcc* <sup>2</sup> , JMP, BSR, JSR, RTS	—	5
System control	TRAPA, RTE, SLEEP, LDC, STC, ANDC, ORC, XORC, NOP	—	9
Block data transfer	EEPMOV	—	1

Notes: B-byte size; W-word size; L-longword size.

\*1 POP.W Rn and PUSH.W Rn are identical to MOV.W @SP+, Rn and MOV.W Rn, @-SP. POP.L ERn and PUSH.L ERn are identical to MOV.L @SP+, ERn and MOV.L ERn, @-SP.

\*2 Bcc is the general name for conditional branch instructions.

\*3 Not available in the H8S/2633 Series.

\*4 When using the TAS instruction, use register ER0, ER1, ER4, or ER5.



## 2.6.2 Instructions and Addressing Modes

Table 2-2 indicates the combinations of instructions and addressing modes that the H8S/2600 CPU can use.

**Table 2-2 Combinations of Instructions and Addressing Modes**

Function	Instruction	Addressing Modes													
		#xx	Rn	@ERn	@(d:16,ERn)	@(d:32,ERn)	@-ERn/@ERn+	@aa:8	@aa:16	@aa:24	@aa:32	@(d:8,PC)	@(d:16,PC)	@aa:8	—
Data transfer	MOV	BWL	BWL	BWL	BWL	BWL	BWL	B	BWL	—	—	—	—	—	—
	POP, PUSH	—	—	—	—	—	—	—	—	—	—	—	—	WL	—
	LDM, STM	—	—	—	—	—	—	—	—	—	—	—	—	L	—
Arithmetic operations	MOVEPE <sup>*1</sup> , MOVE <sup>*1</sup>	—	—	—	—	—	—	—	—	—	—	B	—	—	—
	ADD, CMP	BWL	BWL	—	—	—	—	—	—	—	—	—	—	—	—
	SUB	WL	BWL	—	—	—	—	—	—	—	—	—	—	—	—
	ADDX, SUBX	B	B	—	—	—	—	—	—	—	—	—	—	—	—
	ADD, SUBS	—	L	—	—	—	—	—	—	—	—	—	—	—	—
	INC, DEC	—	BWL	—	—	—	—	—	—	—	—	—	—	—	—
	DAA, DAS	—	B	—	—	—	—	—	—	—	—	—	—	—	—
	MULXU, DIVXU	—	BW	—	—	—	—	—	—	—	—	—	—	—	—
	MULXS, DIVXS	—	BW	—	—	—	—	—	—	—	—	—	—	—	—
	NEG	—	BWL	—	—	—	—	—	—	—	—	—	—	—	—
	EXTU, EXTS	—	WL	—	—	—	—	—	—	—	—	—	—	—	—
	TAS <sup>*2</sup>	—	—	B	—	—	—	—	—	—	—	—	—	—	—
	MAC	—	—	—	—	—	—	—	—	—	—	—	—	—	—
	CLRMAC	—	—	—	—	—	—	—	—	—	—	—	—	—	—
LDMAC, STMAC	—	L	—	—	—	—	—	—	—	—	—	—	—	—	

Function	Instruction	Addressing Modes														
		#xx	Rn	@ERn	@(d:16,ERn)	@(d:32,ERn)	@-ERn@ERn+	@aa:8	@aa:16	@aa:24	@aa:32	@(d:8,PC)	@(d:16,PC)	@aa:8	—	
Logic operations	AND, OR, XOR	BWL	BWL	—	—	—	—	—	—	—	—	—	—	—	—	—
	NOT	—	BWL	—	—	—	—	—	—	—	—	—	—	—	—	—
Shift		—	BWL	—	—	—	—	—	—	—	—	—	—	—	—	—
Bit manipulation	Bcc, BSR	—	B	B	—	—	—	—	—	—	—	—	—	—	—	—
	JMP, JSR	—	—	—	—	—	—	—	—	—	—	—	—	—	—	—
System control	RTS	—	—	—	—	—	—	—	—	—	—	—	—	—	—	—
	TRAPA	—	—	—	—	—	—	—	—	—	—	—	—	—	—	—
	RTE	—	—	—	—	—	—	—	—	—	—	—	—	—	—	—
	SLEEP	—	—	—	—	—	—	—	—	—	—	—	—	—	—	—
	LDC	B	B	W	W	W	W	—	W	—	W	—	—	—	—	—
	STC	—	B	W	W	W	W	—	W	—	W	—	—	—	—	—
Block data transfer	ANDC, ORC, XORC	B	—	—	—	—	—	—	—	—	—	—	—	—	—	—
	NOP	—	—	—	—	—	—	—	—	—	—	—	—	—	—	—

**Legend**

B: Byte

W: Word

L: Longword

Notes: \*1 Not available in the H8S/2633 Series.

\*2 When using the TAS instruction, use register ER0, ER1, ER4, or ER5.

### 2.6.3 Table of Instructions Classified by Function

Table 2-3 summarizes the instructions in each functional category. The notation used in table 2-3 is defined below.

#### Operation Notation

Rd	General register (destination)*
Rs	General register (source)*
Rn	General register*
ERn	General register (32-bit register)
MAC	Multiply-accumulate register (32-bit register)
(EAd)	Destination operand
(EAs)	Source operand
EXR	Extended control register
CCR	Condition-code register
N	N (negative) flag in CCR
Z	Z (zero) flag in CCR
V	V (overflow) flag in CCR
C	C (carry) flag in CCR
PC	Program counter
SP	Stack pointer
#IMM	Immediate data
disp	Displacement
+	Addition
-	Subtraction
×	Multiplication
÷	Division
^	Logical AND
∨	Logical OR
⊕	Logical exclusive OR
→	Move
¬	NOT (logical complement)
:8/:16/:24/:32	8-, 16-, 24-, or 32-bit length

Note: \* General registers include 8-bit registers (R0H to R7H, R0L to R7L), 16-bit registers (R0 to R7, E0 to E7), and 32-bit registers (ER0 to ER7).

**Table 2-3 Instructions Classified by Function**

Type	Instruction	Size* <sup>1</sup>	Function
Data transfer	MOV	B/W/L	(EAs) → Rd, Rs → (Ead) Moves data between two general registers or between a general register and memory, or moves immediate data to a general register.
	MOVFPPE	B	Cannot be used in the H8S/2633 Series.
	MOVTPPE	B	Cannot be used in the H8S/2633 Series.
	POP	W/L	@SP+ → Rn Pops a register from the stack. POP.W Rn is identical to MOV.W @SP+, Rn. POP.L ERn is identical to MOV.L @SP+, ERn.
	PUSH	W/L	Rn → @-SP Pushes a register onto the stack. PUSH.W Rn is identical to MOV.W Rn, @-SP. PUSH.L ERn is identical to MOV.L ERn, @-SP.
	LDM	L	@SP+ → Rn (register list) Pops two or more general registers from the stack.
	STM	L	Rn (register list) → @-SP Pushes two or more general registers onto the stack.
	Arithmetic operations	ADD SUB	B/W/L
ADDX SUBX		B	Rd ± Rs ± C → Rd, Rd ± #IMM ± C → Rd Performs addition or subtraction with carry or borrow on byte data in two general registers, or on immediate data and data in a general register.
INC DEC		B/W/L	Rd ± 1 → Rd, Rd ± 2 → Rd Increments or decrements a general register by 1 or 2. (Byte operands can be incremented or decremented by 1 only.)
ADDS SUBS		L	Rd ± 1 → Rd, Rd ± 2 → Rd, Rd ± 4 → Rd Adds or subtracts the value 1, 2, or 4 to or from data in a 32-bit register.
DAA DAS		B	Rd decimal adjust → Rd Decimal-adjusts an addition or subtraction result in a general register by referring to the CCR to produce 4-bit BCD data.

Type	Instruction	Size* <sup>1</sup>	Function
Arithmetic operations	MULXU	B/W	$Rd \times Rs \rightarrow Rd$ Performs unsigned multiplication on data in two general registers: either 8 bits $\times$ 8 bits $\rightarrow$ 16 bits or 16 bits $\times$ 16 bits $\rightarrow$ 32 bits.
	MULXS	B/W	$Rd \times Rs \rightarrow Rd$ Performs signed multiplication on data in two general registers: either 8 bits $\times$ 8 bits $\rightarrow$ 16 bits or 16 bits $\times$ 16 bits $\rightarrow$ 32 bits.
	DIVXU	B/W	$Rd \div Rs \rightarrow Rd$ Performs unsigned division on data in two general registers: either 16 bits $\div$ 8 bits $\rightarrow$ 8-bit quotient and 8-bit remainder or 32 bits $\div$ 16 bits $\rightarrow$ 16-bit quotient and 16-bit remainder.
	DIVXS	B/W	$Rd \div Rs \rightarrow Rd$ Performs signed division on data in two general registers: either 16 bits $\div$ 8 bits $\rightarrow$ 8-bit quotient and 8-bit remainder or 32 bits $\div$ 16 bits $\rightarrow$ 16-bit quotient and 16-bit remainder.
	CMP	B/W/L	$Rd - Rs, Rd - \#IMM$ Compares data in a general register with data in another general register or with immediate data, and sets CCR bits according to the result.
	NEG	B/W/L	$0 - Rd \rightarrow Rd$ Takes the two's complement (arithmetic complement) of data in a general register.
	EXTU	W/L	$Rd$ (zero extension) $\rightarrow Rd$ Extends the lower 8 bits of a 16-bit register to word size, or the lower 16 bits of a 32-bit register to longword size, by padding with zeros on the left.
	EXTS	W/L	$Rd$ (sign extension) $\rightarrow Rd$ Extends the lower 8 bits of a 16-bit register to word size, or the lower 16 bits of a 32-bit register to longword size, by extending the sign bit.
	TAS* <sup>2</sup>	B	$@ERd - 0, 1 \rightarrow (<bit 7> \text{ of } @ERd)$ Tests memory contents, and sets the most significant bit (bit 7) to 1.
	MAC	—	$(EAs) \times (EAd) + MAC \rightarrow MAC$ Performs signed multiplication on memory contents and adds the result to the multiply-accumulate register. The following operations can be performed: 16 bits $\times$ 16 bits + 32 bits $\rightarrow$ 32 bits, saturating 16 bits $\times$ 16 bits + 42 bits $\rightarrow$ 42 bits, non-saturating

Type	Instruction	Size* <sup>1</sup>	Function
Arithmetic operations	CLRMAC	—	$0 \rightarrow \text{MAC}$ Clears the multiply-accumulate register to zero.
	LDMAC STMAC	L	$R_s \rightarrow \text{MAC}, \text{MAC} \rightarrow R_d$ Transfers data between a general register and a multiply-accumulate register.
Logic operations	AND	B/W/L	$R_d \wedge R_s \rightarrow R_d, R_d \wedge \#IMM \rightarrow R_d$ Performs a logical AND operation on a general register and another general register or immediate data.
	OR	B/W/L	$R_d \vee R_s \rightarrow R_d, R_d \vee \#IMM \rightarrow R_d$ Performs a logical OR operation on a general register and another general register or immediate data.
	XOR	B/W/L	$R_d \oplus R_s \rightarrow R_d, R_d \oplus \#IMM \rightarrow R_d$ Performs a logical exclusive OR operation on a general register and another general register or immediate data.
	NOT	B/W/L	$\neg (R_d) \rightarrow (R_d)$ Takes the one's complement of general register contents.
Shift operations	SHAL SHAR	B/W/L	$R_d (\text{shift}) \rightarrow R_d$ Performs an arithmetic shift on general register contents. 1-bit or 2-bit shift is possible.
	SHLL SHLR	B/W/L	$R_d (\text{shift}) \rightarrow R_d$ Performs a logical shift on general register contents. 1-bit or 2-bit shift is possible.
	ROTL ROTR	B/W/L	$R_d (\text{rotate}) \rightarrow R_d$ Rotates general register contents. 1-bit or 2-bit rotation is possible.
	ROTXL ROTXR	B/W/L	$R_d (\text{rotate}) \rightarrow R_d$ Rotates general register contents through the carry flag. 1-bit or 2-bit rotation is possible.
	Bit-manipulation instructions	BSET	B
BCLR		B	$0 \rightarrow (\text{<bit-No.> of <EAd>})$ Clears a specified bit in a general register or memory operand to 0. The bit number is specified by 3-bit immediate data or the lower three bits of a general register.
BNOT		B	$\neg (\text{<bit-No.> of <EAd>}) \rightarrow (\text{<bit-No.> of <EAd>})$ Inverts a specified bit in a general register or memory operand. The bit number is specified by 3-bit immediate data or the lower three bits of a general register.

Type	Instruction	Size* <sup>1</sup>	Function
Bit-manipulation instructions	BTST	B	$\neg (\text{<bit-No.> of <EAd>}) \rightarrow Z$ Tests a specified bit in a general register or memory operand and sets or clears the Z flag accordingly. The bit number is specified by 3-bit immediate data or the lower three bits of a general register.
	BAND	B	$C \wedge (\text{<bit-No.> of <EAd>}) \rightarrow C$ ANDs the carry flag with a specified bit in a general register or memory operand and stores the result in the carry flag.
	BIAND	B	$C \wedge \neg (\text{<bit-No.> of <EAd>}) \rightarrow C$ ANDs the carry flag with the inverse of a specified bit in a general register or memory operand and stores the result in the carry flag. The bit number is specified by 3-bit immediate data.
	BOR	B	$C \vee (\text{<bit-No.> of <EAd>}) \rightarrow C$ ORs the carry flag with a specified bit in a general register or memory operand and stores the result in the carry flag.
	BIOR	B	$C \vee \neg (\text{<bit-No.> of <EAd>}) \rightarrow C$ ORs the carry flag with the inverse of a specified bit in a general register or memory operand and stores the result in the carry flag. The bit number is specified by 3-bit immediate data.
	BXOR	B	$C \oplus (\text{<bit-No.> of <EAd>}) \rightarrow C$ Exclusive-ORs the carry flag with a specified bit in a general register or memory operand and stores the result in the carry flag.
	BIXOR	B	$C \oplus \neg (\text{<bit-No.> of <EAd>}) \rightarrow C$ Exclusive-ORs the carry flag with the inverse of a specified bit in a general register or memory operand and stores the result in the carry flag. The bit number is specified by 3-bit immediate data.
	BLD	B	$(\text{<bit-No.> of <EAd>}) \rightarrow C$ Transfers a specified bit in a general register or memory operand to the carry flag.
	BILD	B	$\neg (\text{<bit-No.> of <EAd>}) \rightarrow C$ Transfers the inverse of a specified bit in a general register or memory operand to the carry flag. The bit number is specified by 3-bit immediate data.

Type	Instruction	Size* <sup>1</sup>	Function		
Bit-manipulation instructions	BST	B	$C \rightarrow (<\text{bit-No.}> \text{ of } <\text{EAd}>)$ Transfers the carry flag value to a specified bit in a general register or memory operand.		
	BIST	B	$\neg C \rightarrow (<\text{bit-No.}> \text{ of } <\text{EAd}>)$ Transfers the inverse of the carry flag value to a specified bit in a general register or memory operand. The bit number is specified by 3-bit immediate data.		
Branch instructions	Bcc	—	Branches to a specified address if a specified condition is true. The branching conditions are listed below.		
			<b>Mnemonic</b>	<b>Description</b>	<b>Condition</b>
			BRA(BT)	Always (true)	Always
			BRN(BF)	Never (false)	Never
			BHI	High	$C \vee Z = 0$
			BLS	Low or same	$C \vee Z = 1$
			BCC(BHS)	Carry clear (high or same)	$C = 0$
			BCS(BLO)	Carry set (low)	$C = 1$
			BNE	Not equal	$Z = 0$
			BEQ	Equal	$Z = 1$
			BVC	Overflow clear	$V = 0$
			BVS	Overflow set	$V = 1$
			BPL	Plus	$N = 0$
			BMI	Minus	$N = 1$
			BGE	Greater or equal	$N \oplus V = 0$
			BLT	Less than	$N \oplus V = 1$
BGT	Greater than	$Z \vee (N \oplus V) = 0$			
BLE	Less or equal	$Z \vee (N \oplus V) = 1$			
	JMP	—	Branches unconditionally to a specified address.		
	BSR	—	Branches to a subroutine at a specified address.		
	JSR	—	Branches to a subroutine at a specified address.		
	RTS	—	Returns from a subroutine.		
System control instructions	TRAPA	—	Starts trap-instruction exception handling.		
	RTE	—	Returns from an exception-handling routine.		
	SLEEP	—	Causes a transition to a power-down state.		



Type	Instruction	Size* <sup>1</sup>	Function
System control instructions	LDC	B/W	(EAs) → CCR, (EAs) → EXR Moves the source operand contents or immediate data to CCR or EXR. Although CCR and EXR are 8-bit registers, word-size transfers are performed between them and memory. The upper 8 bits are valid.
	STC	B/W	CCR → (EAd), EXR → (EAd) Transfers CCR or EXR contents to a general register or memory. Although CCR and EXR are 8-bit registers, word-size transfers are performed between them and memory. The upper 8 bits are valid.
	ANDC	B	CCR ∧ #IMM → CCR, EXR ∧ #IMM → EXR Logically ANDs the CCR or EXR contents with immediate data.
	ORC	B	CCR ∨ #IMM → CCR, EXR ∨ #IMM → EXR Logically ORs the CCR or EXR contents with immediate data.
	XORC	B	CCR ⊕ #IMM → CCR, EXR ⊕ #IMM → EXR Logically exclusive-ORs the CCR or EXR contents with immediate data.
	NOP	—	PC + 2 → PC Only increments the program counter.
Block data transfer instruction	EEPMOV.B	—	if R4L ≠ 0 then Repeat @ER5+ → @ER6+ R4L-1 → R4L Until R4L = 0 else next;
	EEPMOV.W	—	if R4 ≠ 0 then Repeat @ER5+ → @ER6+ R4-1 → R4 Until R4 = 0 else next;  Transfers a data block according to parameters set in general registers R4L or R4, ER5, and ER6.  R4L or R4: size of block (bytes) ER5: starting source address ER6: starting destination address  Execution of the next instruction begins as soon as the transfer is completed.

Notes: \*1 Size refers to the operand size.

B: Byte

W: Word

L: Longword

\*2 When using the TAS instruction, use register ER0, ER1, ER4, or ER5.

#### 2.6.4 Basic Instruction Formats

The H8S/2633 Series instructions consist of 2-byte (1-word) units. An instruction consists of an operation field (op field), a register field (r field), an effective address extension (EA field), and a condition field (cc).

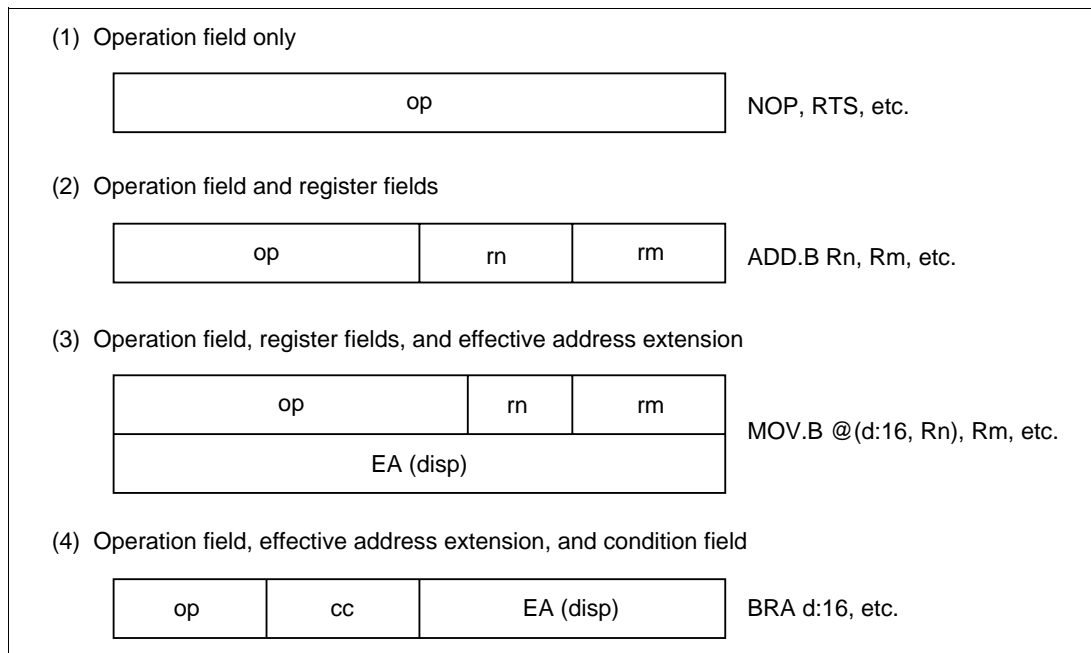
**(1) Operation Field:** Indicates the function of the instruction, the addressing mode, and the operation to be carried out on the operand. The operation field always includes the first 4 bits of the instruction. Some instructions have two operation fields.

**(2) Register Field:** Specifies a general register. Address registers are specified by 3 bits, data registers by 3 bits or 4 bits. Some instructions have two register fields. Some have no register field.

**(3) Effective Address Extension:** Eight, 16, or 32 bits specifying immediate data, an absolute address, or a displacement.

**(4) Condition Field:** Specifies the branching condition of Bcc instructions.

Figure 2-12 shows examples of instruction formats.



**Figure 2-12 Instruction Formats (Examples)**

## 2.7 Addressing Modes and Effective Address Calculation

### 2.7.1 Addressing Mode

The CPU supports the eight addressing modes listed in table 2-4. Each instruction uses a subset of these addressing modes. Arithmetic and logic instructions can use the register direct and immediate modes. Data transfer instructions can use all addressing modes except program-counter relative and memory indirect. Bit manipulation instructions use register direct, register indirect, or absolute addressing mode to specify an operand, and register direct (BSET, BCLR, BNOT, and BTST instructions) or immediate (3-bit) addressing mode to specify a bit number in the operand.

**Table 2-4 Addressing Modes**

No.	Addressing Mode	Symbol
1	Register direct	Rn
2	Register indirect	@ERn
3	Register indirect with displacement	@(d:16,ERn)/@(d:32,ERn)
4	Register indirect with post-increment Register indirect with pre-decrement	@ERn+ @-ERn
5	Absolute address	@aa:8/@aa:16/@aa:24/@aa:32
6	Immediate	#xx:8/#xx:16/#xx:32
7	Program-counter relative	@(d:8,PC)/@(d:16,PC)
8	Memory indirect	@@aa:8

(1) **Register Direct—Rn:** The register field of the instruction specifies an 8-, 16-, or 32-bit general register containing the operand. R0H to R7H and R0L to R7L can be specified as 8-bit registers. R0 to R7 and E0 to E7 can be specified as 16-bit registers. ER0 to ER7 can be specified as 32-bit registers.

(2) **Register Indirect—@ERn:** The register field of the instruction code specifies an address register (ERn) which contains the address of the operand on memory. If the address is a program instruction address, the lower 24 bits are valid and the upper 8 bits are all assumed to be 0 (H'00).

(3) **Register Indirect with Displacement—@(d:16, ERn) or @(d:32, ERn):** A 16-bit or 32-bit displacement contained in the instruction is added to an address register (ERn) specified by the register field of the instruction, and the sum gives the address of a memory operand. A 16-bit displacement is sign-extended when added.

**(4) Register Indirect with Post-Increment or Pre-Decrement—@ERn+ or @-ERn:**

- Register indirect with post-increment—@ERn+

The register field of the instruction code specifies an address register (ERn) which contains the address of a memory operand. After the operand is accessed, 1, 2, or 4 is added to the address register contents and the sum is stored in the address register. The value added is 1 for byte access, 2 for word transfer instruction, or 4 for longword transfer instruction. For word or longword transfer instruction, the register value should be even.

- Register indirect with pre-decrement—@-ERn

The value 1, 2, or 4 is subtracted from an address register (ERn) specified by the register field in the instruction code, and the result becomes the address of a memory operand. The result is also stored in the address register. The value subtracted is 1 for byte access, 2 for word transfer instruction, or 4 for longword transfer instruction. For word or longword transfer instruction, the register value should be even.

**(5) Absolute Address—@aa:8, @aa:16, @aa:24, or @aa:32:** The instruction code contains the absolute address of a memory operand. The absolute address may be 8 bits long (@aa:8), 16 bits long (@aa:16), 24 bits long (@aa:24), or 32 bits long (@aa:32).

To access data, the absolute address should be 8 bits (@aa:8), 16 bits (@aa:16), or 32 bits (@aa:32) long. For an 8-bit absolute address, the upper 24 bits are all assumed to be 1 (H'FFFF). For a 16-bit absolute address the upper 16 bits are a sign extension. A 32-bit absolute address can access the entire address space.

A 24-bit absolute address (@aa:24) indicates the address of a program instruction. The upper 8 bits are all assumed to be 0 (H'00).

Table 2-5 indicates the accessible absolute address ranges.

**Table 2-5 Absolute Address Access Ranges**

<b>Absolute Address</b>		<b>Normal Mode*</b>	<b>Advanced Mode</b>
Data address	8 bits (@aa:8)	H'FF00 to H'FFFF	H'FFFF00 to H'FFFFFF
	16 bits (@aa:16)	H'0000 to H'FFFF	H'000000 to H'007FFF, H'FF8000 to H'FFFFFF
	32 bits (@aa:32)		H'000000 to H'FFFFFF
Program instruction address	24 bits (@aa:24)		

Note: \* Not available in the H8S/2633 Series.

**(6) Immediate—#xx:8, #xx:16, or #xx:32:** The instruction contains 8-bit (#xx:8), 16-bit (#xx:16), or 32-bit (#xx:32) immediate data as an operand.

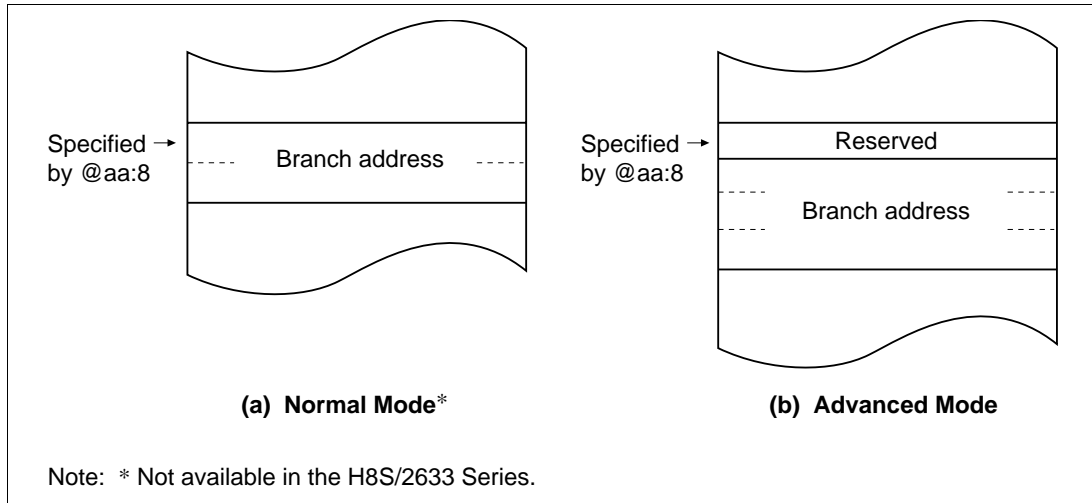
The ADDS, SUBS, INC, and DEC instructions contain immediate data implicitly. Some bit manipulation instructions contain 3-bit immediate data in the instruction code, specifying a bit number. The TRAPA instruction contains 2-bit immediate data in its instruction code, specifying a vector address.

**(7) Program-Counter Relative—@(d:8, PC) or @(d:16, PC):** This mode is used in the Bcc and BSR instructions. An 8-bit or 16-bit displacement contained in the instruction is sign-extended and added to the 24-bit PC contents to generate a branch address. Only the lower 24 bits of this branch address are valid; the upper 8 bits are all assumed to be 0 (H'00). The PC value to which the displacement is added is the address of the first byte of the next instruction, so the possible branching range is -126 to +128 bytes (-63 to +64 words) or -32766 to +32768 bytes (-16383 to +16384 words) from the branch instruction. The resulting value should be an even number.

**(8) Memory Indirect—@@aa:8:** This mode can be used by the JMP and JSR instructions. The instruction code contains an 8-bit absolute address specifying a memory operand. This memory operand contains a branch address. The upper bits of the absolute address are all assumed to be 0, so the address range is 0 to 255 (H'0000 to H'00FF in normal mode, H'000000 to H'0000FF in advanced mode). In normal mode\* the memory operand is a word operand and the branch address is 16 bits long. In advanced mode the memory operand is a longword operand, the first byte of which is assumed to be all 0 (H'00).

Note that the first part of the address range is also the exception vector area. For further details, refer to section 4, Exception Handling.

Note: \* Not available in the H8S/2633 Series.



**Figure 2-13 Branch Address Specification in Memory Indirect Mode**

If an odd address is specified in word or longword memory access, or as a branch address, the least significant bit is regarded as 0, causing data to be accessed or instruction code to be fetched at the address preceding the specified address. (For further information, see section 2.5.2, Memory Data Formats.)

### 2.7.2 Effective Address Calculation

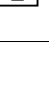
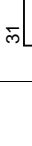






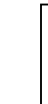
Table 2-6 indicates how effective addresses are calculated in each addressing mode. In normal mode\* the upper 8 bits of the effective address are ignored in order to generate a 16-bit address.

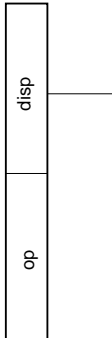
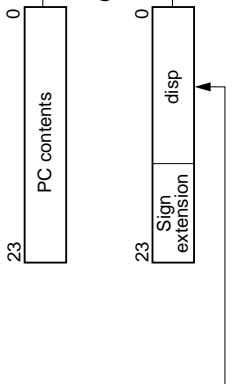
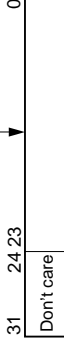


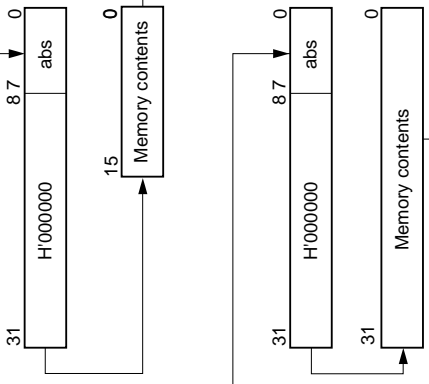
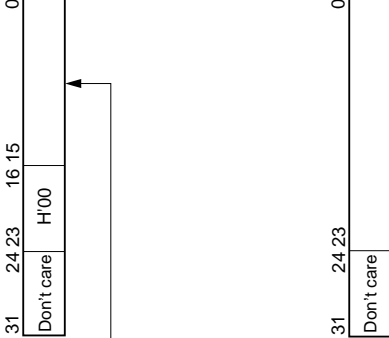
Note: \* Not available in the H8S/2633 Series.

**Table 2-6 Effective Address Calculation**

No.	Addressing Mode and Instruction Format	Effective Address Calculation	Effective Address (EA)								
1	Register direct (Rn) <div style="display: flex; justify-content: center; align-items: center; gap: 10px;"> <div style="border: 1px solid black; padding: 2px;">op</div> <div style="border: 1px solid black; padding: 2px;">rm</div> <div style="border: 1px solid black; padding: 2px;">rn</div> </div>		Operand is general register contents.								
2	Register indirect (@ERn) <div style="display: flex; justify-content: center; align-items: center; gap: 10px;"> <div style="border: 1px solid black; padding: 2px;">op</div> <div style="border: 1px solid black; padding: 2px;">r</div> </div>	<div style="display: flex; justify-content: center; align-items: center; gap: 10px;"> <div style="border: 1px solid black; padding: 2px; width: 150px; height: 20px;">General register contents</div> <div style="border: 1px solid black; padding: 2px; width: 40px; height: 20px;">0</div> </div>	<div style="display: flex; justify-content: center; align-items: center; gap: 10px;"> <div style="border: 1px solid black; padding: 2px; width: 150px; height: 20px;">31</div> <div style="border: 1px solid black; padding: 2px; width: 40px; height: 20px;">Don't care</div> <div style="border: 1px solid black; padding: 2px; width: 40px; height: 20px;">24</div> <div style="border: 1px solid black; padding: 2px; width: 40px; height: 20px;">23</div> <div style="border: 1px solid black; padding: 2px; width: 40px; height: 20px;">0</div> </div>								
3	Register indirect with displacement @(d:16, ERn) or @(d:32, ERn) <div style="display: flex; justify-content: center; align-items: center; gap: 10px;"> <div style="border: 1px solid black; padding: 2px;">op</div> <div style="border: 1px solid black; padding: 2px;">r</div> <div style="border: 1px solid black; padding: 2px; width: 60px; height: 20px;">disp</div> </div>	<div style="display: flex; justify-content: center; align-items: center; gap: 10px;"> <div style="border: 1px solid black; padding: 2px; width: 150px; height: 20px;">General register contents</div> <div style="border: 1px solid black; padding: 2px; width: 40px; height: 20px;">0</div> <div style="border: 1px solid black; padding: 2px; width: 100px; height: 20px;">Sign extension</div> <div style="border: 1px solid black; padding: 2px; width: 40px; height: 20px;">0</div> <div style="border: 1px solid black; padding: 2px; width: 40px; height: 20px;">disp</div> </div>	<div style="display: flex; justify-content: center; align-items: center; gap: 10px;"> <div style="border: 1px solid black; padding: 2px; width: 150px; height: 20px;">31</div> <div style="border: 1px solid black; padding: 2px; width: 40px; height: 20px;">Don't care</div> <div style="border: 1px solid black; padding: 2px; width: 40px; height: 20px;">24</div> <div style="border: 1px solid black; padding: 2px; width: 40px; height: 20px;">23</div> <div style="border: 1px solid black; padding: 2px; width: 40px; height: 20px;">0</div> </div>								
4	Register indirect with post-increment or pre-decrement • Register indirect with post-increment @ERn+ <div style="display: flex; justify-content: center; align-items: center; gap: 10px;"> <div style="border: 1px solid black; padding: 2px;">op</div> <div style="border: 1px solid black; padding: 2px;">r</div> </div> • Register indirect with pre-decrement @-ERn <div style="display: flex; justify-content: center; align-items: center; gap: 10px;"> <div style="border: 1px solid black; padding: 2px;">op</div> <div style="border: 1px solid black; padding: 2px;">r</div> </div>	<div style="display: flex; justify-content: center; align-items: center; gap: 10px;"> <div style="border: 1px solid black; padding: 2px; width: 150px; height: 20px;">General register contents</div> <div style="border: 1px solid black; padding: 2px; width: 40px; height: 20px;">0</div> <div style="border: 1px solid black; padding: 2px; width: 40px; height: 20px;">1, 2, or 4</div> </div> <div style="display: flex; justify-content: center; align-items: center; gap: 10px;"> <div style="border: 1px solid black; padding: 2px; width: 150px; height: 20px;">General register contents</div> <div style="border: 1px solid black; padding: 2px; width: 40px; height: 20px;">0</div> <div style="border: 1px solid black; padding: 2px; width: 40px; height: 20px;">1, 2, or 4</div> </div> <table border="1" style="margin-left: auto; margin-right: auto;"> <thead> <tr> <th>Operand Size</th> <th>Value added</th> </tr> </thead> <tbody> <tr> <td>Byte</td> <td>1</td> </tr> <tr> <td>Word</td> <td>2</td> </tr> <tr> <td>Longword</td> <td>4</td> </tr> </tbody> </table>	Operand Size	Value added	Byte	1	Word	2	Longword	4	<div style="display: flex; justify-content: center; align-items: center; gap: 10px;"> <div style="border: 1px solid black; padding: 2px; width: 150px; height: 20px;">31</div> <div style="border: 1px solid black; padding: 2px; width: 40px; height: 20px;">Don't care</div> <div style="border: 1px solid black; padding: 2px; width: 40px; height: 20px;">24</div> <div style="border: 1px solid black; padding: 2px; width: 40px; height: 20px;">23</div> <div style="border: 1px solid black; padding: 2px; width: 40px; height: 20px;">0</div> </div> <div style="display: flex; justify-content: center; align-items: center; gap: 10px;"> <div style="border: 1px solid black; padding: 2px; width: 150px; height: 20px;">31</div> <div style="border: 1px solid black; padding: 2px; width: 40px; height: 20px;">Don't care</div> <div style="border: 1px solid black; padding: 2px; width: 40px; height: 20px;">24</div> <div style="border: 1px solid black; padding: 2px; width: 40px; height: 20px;">23</div> <div style="border: 1px solid black; padding: 2px; width: 40px; height: 20px;">0</div> </div>
Operand Size	Value added										
Byte	1										
Word	2										
Longword	4										



No.	Addressing Mode and Instruction Format	Effective Address Calculation	Effective Address (EA)
5	Absolute address @aa:8 		
	@aa:16 		
	@aa:24 		
	@aa:32 		
6	Immediate #xx:8/#xx:16/#xx:32 		Operand is immediate data.

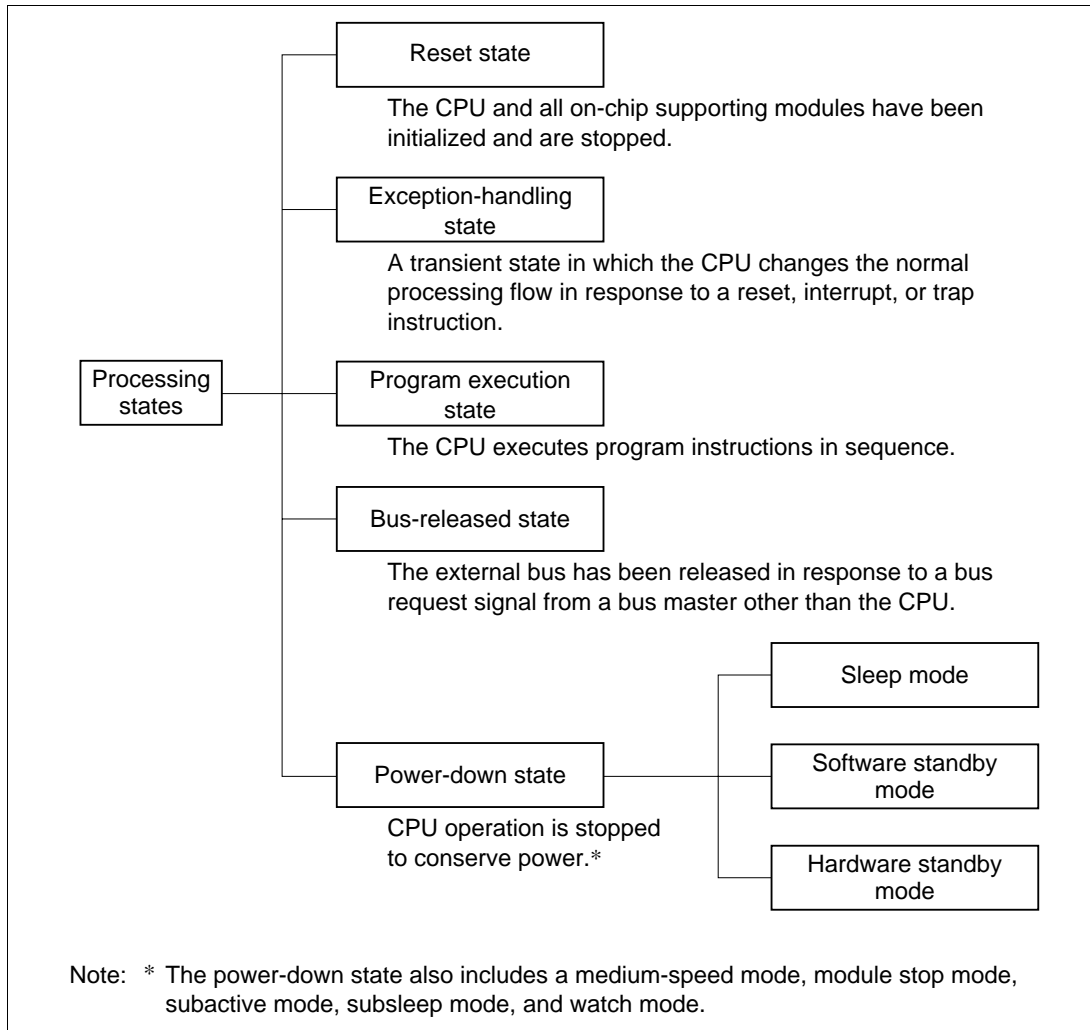
No.	Addressing Mode and Instruction Format	Effective Address Calculation	Effective Address (EA)
7	<p>Program-counter relative @(d:8, PC)/@(d:16, PC)</p> 		
8	<p>Memory indirect @@aa:8</p> <ul style="list-style-type: none"> <li>• Normal mode*</li> </ul>  <ul style="list-style-type: none"> <li>• Advanced mode</li> </ul> 		

Note: \* Not available in the H8S/2633 Series.

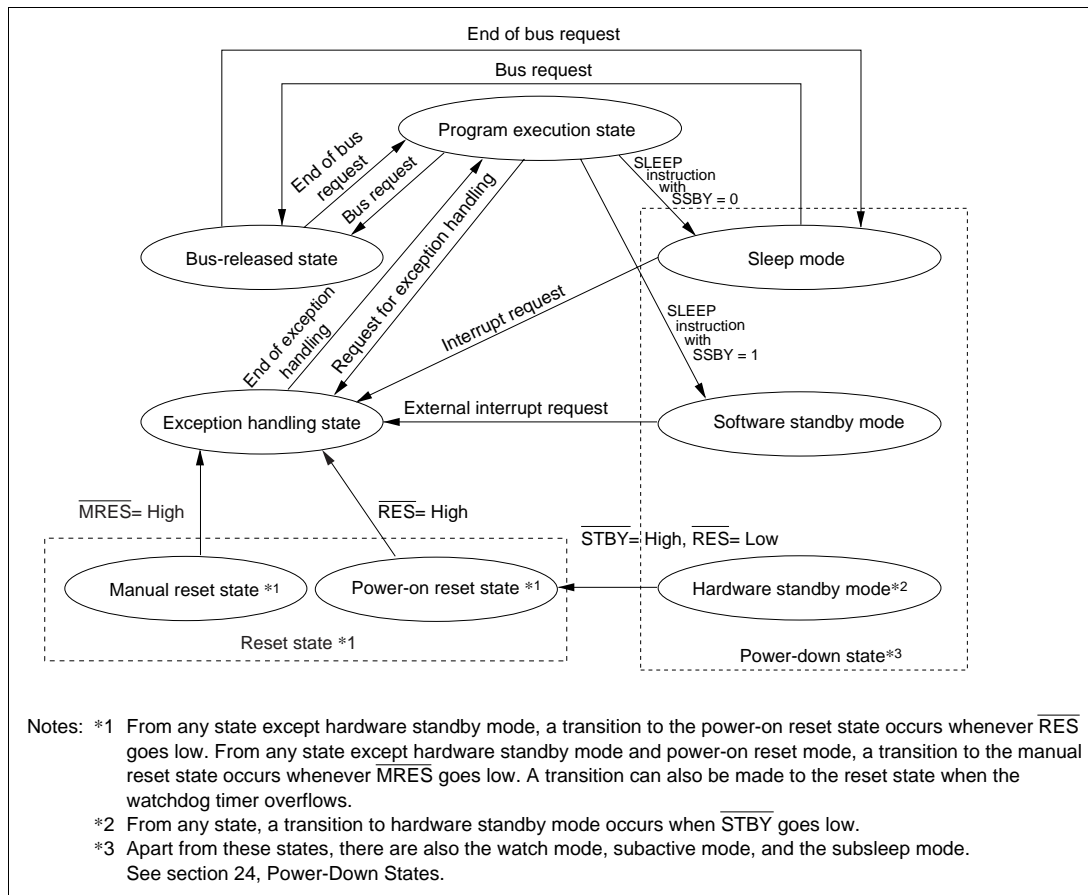
## 2.8 Processing States

### 2.8.1 Overview

The CPU has five main processing states: the reset state, exception handling state, program execution state, bus-released state, and power-down state. Figure 2-14 shows a diagram of the processing states. Figure 2-15 indicates the state transitions.



**Figure 2-14 Processing States**



**Figure 2-15 State Transitions**

## 2.8.2 Reset State

The CPU enters the reset state when the  $\overline{RES}$  pin goes low, or when the  $\overline{MRES}$  pin goes low while manual resets are enabled by the MRESE bit. In the reset state, currently executing processing is halted and all interrupts are disabled.

For details of MRESE bit setting, see section 3.2.2, System Control Register (SYSCR).

Reset exception handling starts when the  $\overline{RES}$  or  $\overline{MRES}$  pin\* changes from low to high.

The reset state can also be entered in the event of watchdog timer overflow. For details see section 15, Watchdog Timer.

Note: \*  $\overline{MRES}$  pin in the case of a manual reset.

### 2.8.3 Exception-Handling State

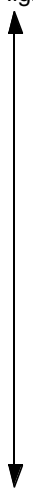
The exception-handling state is a transient state that occurs when the CPU alters the normal processing flow due to a reset, interrupt, or trap instruction. The CPU fetches a start address (vector) from the exception vector table and branches to that address.

#### (1) Types of Exception Handling and Their Priority

Exception handling is performed for traces, resets, interrupts, and trap instructions. Table 2-7 indicates the types of exception handling and their priority. Trap instruction exception handling is always accepted, in the program execution state.

Exception handling and the stack structure depend on the interrupt control mode set in SYSCR.

**Table 2-7 Exception Handling Types and Priority**

Priority	Type of Exception	Detection Timing	Start of Exception Handling
High  Low	Reset	Synchronized with clock	Exception handling starts immediately after a low-to-high transition at the $\overline{\text{RES}}$ pin, or when the watchdog timer overflows.
	Trace	End of instruction execution or end of exception-handling sequence* <sup>1</sup>	When the trace (T) bit is set to 1, the trace starts at the end of the current instruction or current exception-handling sequence
	Interrupt	End of instruction execution or end of exception-handling sequence* <sup>2</sup>	When an interrupt is requested, exception handling starts at the end of the current instruction or current exception-handling sequence
	Trap instruction	When TRAPA instruction is executed	Exception handling starts when a trap (TRAPA) instruction is executed* <sup>3</sup>

- Notes: \*1 Traces are enabled only in interrupt control mode 2. Trace exception-handling is not executed at the end of the RTE instruction.  
 \*2 Interrupts are not detected at the end of the ANDC, ORC, XORC, and LDC instructions, or immediately after reset exception handling.  
 \*3 Trap instruction exception handling is always accepted, in the program execution state.

## (2) Reset Exception Handling

After the  $\overline{\text{RES}}$  pin has gone low and the reset state has been entered, when  $\overline{\text{RES}}$  pin goes high again, reset exception handling starts. After the reset state has been entered by driving the  $\overline{\text{MRES}}$  pin low while manual resets are enabled by the MRESE bit, reset exception handling starts when  $\overline{\text{MRES}}$  pin is driven high again. The CPU enters the power-on reset state when the  $\overline{\text{RES}}$  pin is low, and enters the manual reset state when the  $\overline{\text{MRES}}$  pin is low. When reset exception handling starts the CPU fetches a start address (vector) from the exception vector table and starts program execution from that address. All interrupts, including NMI, are disabled during reset exception handling and after it ends.

## (3) Traces

Traces are enabled only in interrupt control mode 2. Trace mode is entered when the T bit of EXR is set to 1. When trace mode is established, trace exception handling starts at the end of each instruction.

At the end of a trace exception-handling sequence, the T bit of EXR is cleared to 0 and trace mode is cleared. Interrupt masks are not affected.

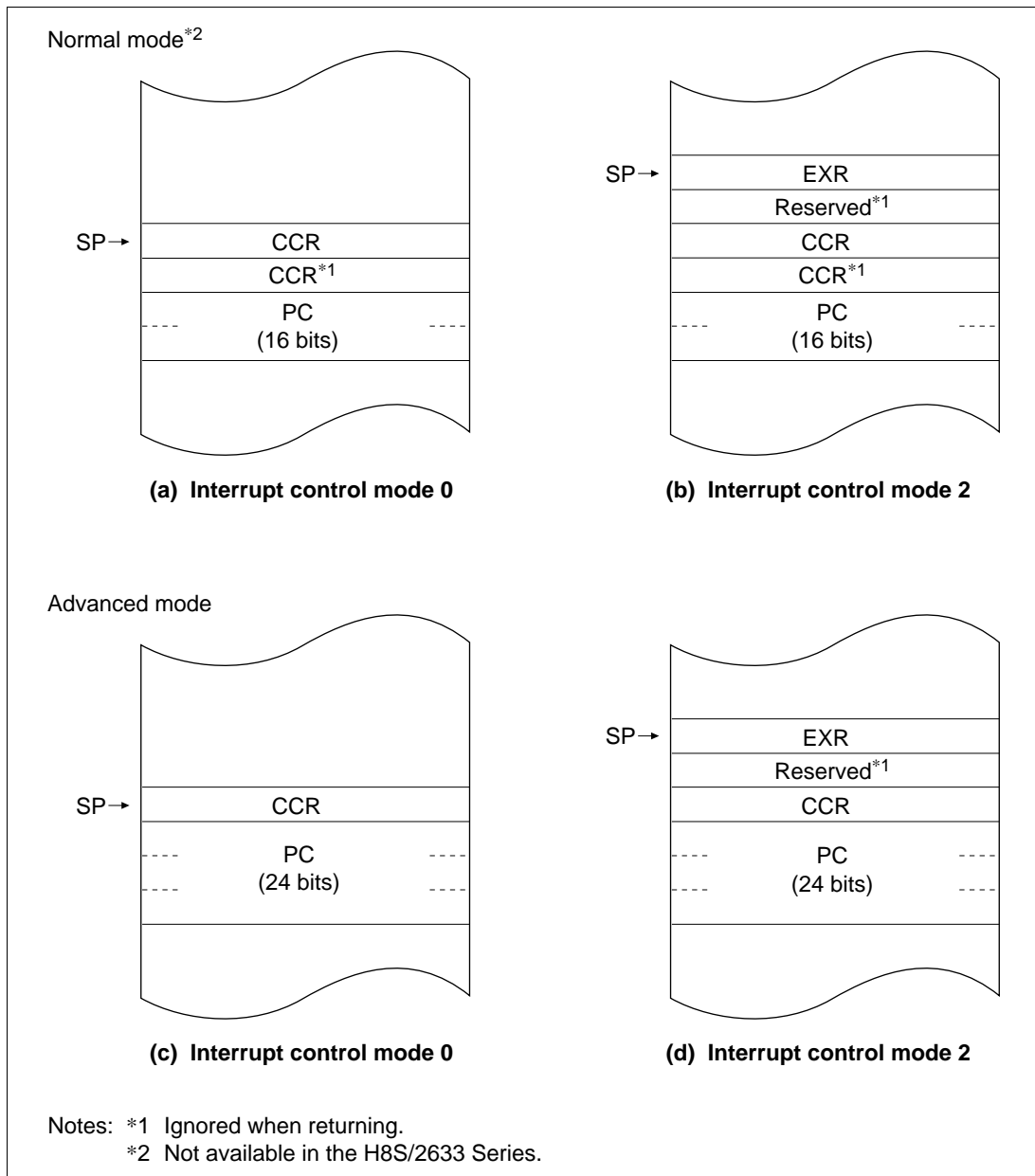
The T bit saved on the stack retains its value of 1, and when the RTE instruction is executed to return from the trace exception-handling routine, trace mode is entered again. Trace exception-handling is not executed at the end of the RTE instruction.

Trace mode is not entered in interrupt control mode 0, regardless of the state of the T bit.

## (4) Interrupt Exception Handling and Trap Instruction Exception Handling

When interrupt or trap-instruction exception handling begins, the CPU references the stack pointer (ER7) and pushes the program counter and other control registers onto the stack. Next, the CPU alters the settings of the interrupt mask bits in the control registers. Then the CPU fetches a start address (vector) from the exception vector table and program execution starts from that start address.

Figure 2-16 shows the stack after exception handling ends.



**Figure 2-16 Stack Structure after Exception Handling (Examples)**

#### 2.8.4 Program Execution State

In this state the CPU executes program instructions in sequence.

#### 2.8.5 Bus-Released State

This is a state in which the bus has been released in response to a bus request from a bus master other than the CPU. While the bus is released, the CPU halts operations.

Bus masters other than the CPU are DMA controller (DMAC)\* and data transfer controller (DTC)\*.

For further details, refer to section 7, Bus Controller.

Note: \* DMAC and DTC functions are not available in the H8S/2695.

#### 2.8.6 Power-Down State

The power-down state includes both modes in which the CPU stops operating and modes in which the CPU does not stop. There are five modes in which the CPU stops operating: sleep mode, software standby mode, hardware standby mode, subsleep mode\*<sup>1</sup>, and watch mode\*<sup>1</sup>. There are also three other power-down modes: medium-speed mode, module stop mode, and subactive mode\*<sup>1</sup>. In medium-speed mode the CPU and other bus masters operate on a medium-speed clock. Module stop mode permits halting of the operation of individual modules, other than the CPU. Subactive mode\*<sup>1</sup>, subsleep mode\*<sup>1</sup>, and watch mode\*<sup>1</sup> are power-down states using subclock input. For details, refer to section 24, Power-Down Modes.

**(1) Sleep Mode:** A transition to sleep mode is made if the SLEEP instruction is executed while the software standby bit (SSBY) in the standby control register (SBYCR) is cleared to 0. In sleep mode, CPU operations stop immediately after execution of the SLEEP instruction. The contents of CPU registers are retained.

**(2) Software Standby Mode:** A transition to software standby mode is made if the SLEEP instruction is executed while the SSBY bit in SBYCR is set to 1, the LSON bit in LPWRCR is set to 0, and the PSS bit in TCSR (WDT1)\*<sup>2</sup> is set to 0. In software standby mode, the CPU and clock halt and all MCU operations stop. As long as a specified voltage is supplied, the contents of CPU registers and on-chip RAM are retained. The I/O ports also remain in their existing states.

**(3) Hardware Standby Mode:** A transition to hardware standby mode is made when the  $\overline{\text{STBY}}$  pin goes low. In hardware standby mode, the CPU and clock halt and all MCU operations stop. The on-chip supporting modules are reset, but as long as a specified voltage is supplied, on-chip RAM contents are retained.

Notes: \*1 This function is not available in the H8S/2695.

\*2 WDT1 is not available in the H8S/2695.



## 2.9 Basic Timing

### 2.9.1 Overview

The H8S/2600 CPU is driven by a system clock, denoted by the symbol  $\phi$ . The period from one rising edge of  $\phi$  to the next is referred to as a "state." The memory cycle or bus cycle consists of one, two, or three states. Different methods are used to access on-chip memory, on-chip supporting modules, and the external address space.

### 2.9.2 On-Chip Memory (ROM, RAM)

On-chip memory is accessed in one state. The data bus is 16 bits wide, permitting both byte and word transfer instruction. Figure 2-17 shows the on-chip memory access cycle. Figure 2-18 shows the pin states.

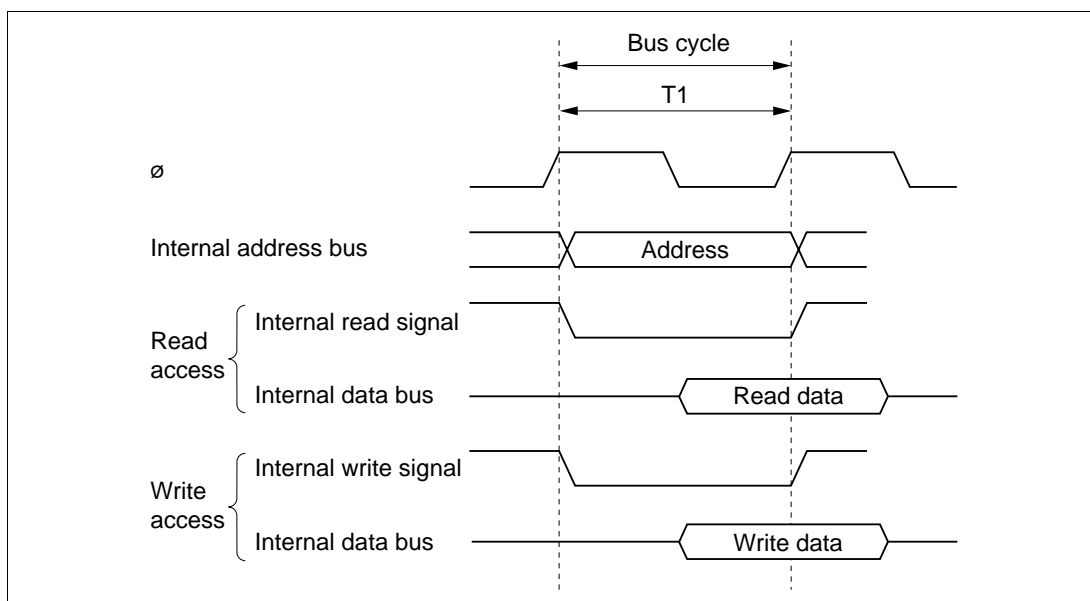
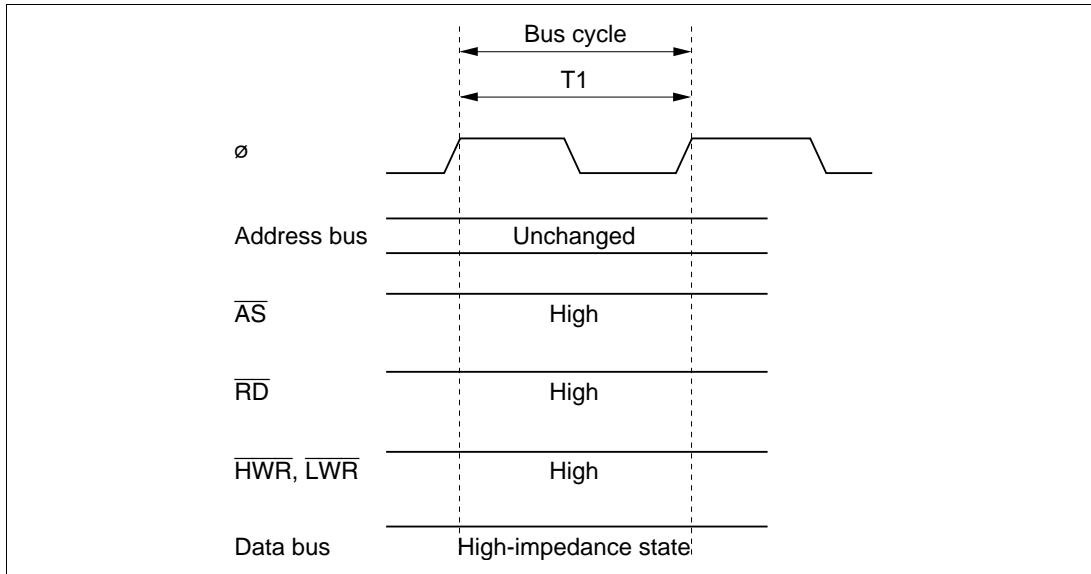


Figure 2-17 On-Chip Memory Access Cycle



**Figure 2-18 Pin States during On-Chip Memory Access**

### 2.9.3 On-Chip Supporting Module Access Timing

The on-chip supporting modules are accessed in two states. The data bus is either 8 bits or 16 bits wide, depending on the particular internal I/O register being accessed. Figure 2-19 shows the access timing for the on-chip supporting modules. Figure 2-20 shows the pin states.

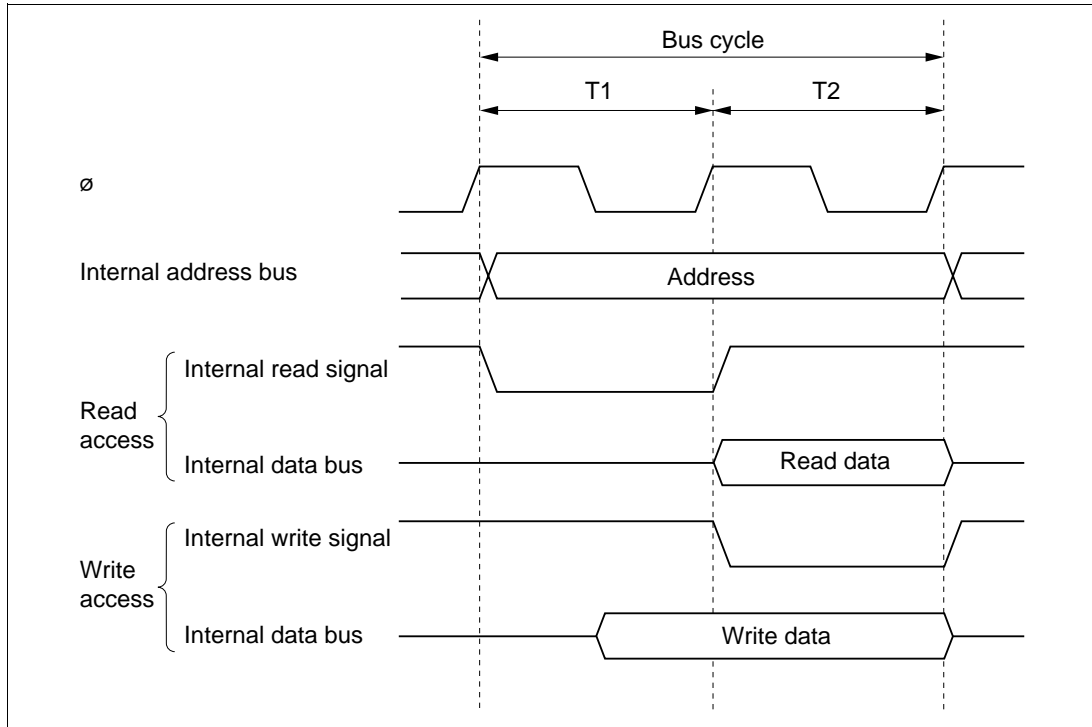
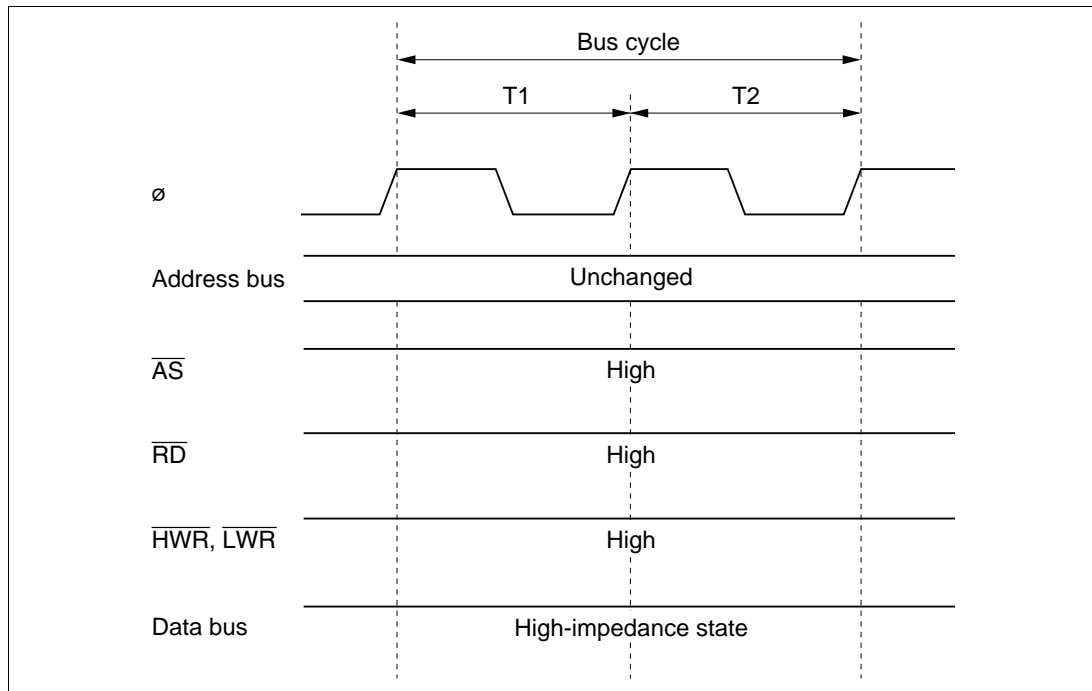


Figure 2-19 On-Chip Supporting Module Access Cycle



**Figure 2-20 Pin States during On-Chip Supporting Module Access**

#### 2.9.4 External Address Space Access Timing

The external address space is accessed with an 8-bit or 16-bit data bus width in a two-state or three-state bus cycle. In three-state access, wait states can be inserted. For further details, refer to section 7, Bus Controller.

### 2.10 Usage Note

#### 2.10.1 TAS Instruction

Only register ER0, ER1, ER4, or ER5 should be used when using the TAS instruction. The TAS instruction is not generated by the Hitachi H8S and H8/300 series C/C++ compilers. If the TAS instruction is used as a user-defined intrinsic function, ensure that only register ER0, ER1, ER4, or ER5 is used.

## Section 3 MCU Operating Modes

### 3.1 Overview

#### 3.1.1 Operating Mode Selection

The H8S/2633 Series has four operating modes (modes 4 to 7). These modes enable selection of the CPU operating mode, enabling/disabling of on-chip ROM, and the initial bus width setting, by setting the mode pins (MD2 to MD0).

Table 3-1 lists the MCU operating modes.

**Table 3-1 MCU Operating Mode Selection**

MCU Operating Mode	MD2	MD1	MD0	CPU Operating Mode	Description	External Data Bus	
						On-Chip ROM	Initial Width
0*	0	0	0	—	—	—	—
1*			1				
2*		1	0				
3*			1				
4	1	0	0	Advanced	On-chip ROM disabled, Disabled expanded mode	16 bits	16 bits
5			1			8 bits	16 bits
6		1	0	Enabled	On-chip ROM enabled, Enabled expanded mode	8 bits	16 bits
7			1		Single-chip mode	—	

Note: \* Not available in the H8S/2633 Series.

The CPU's architecture allows for 4 Gbytes of address space, but the H8S/2633 Series actually accesses a maximum of 16 Mbytes.

Modes 4 to 6 are externally expanded modes that allow access to external memory and peripheral devices.

The external expansion modes allow switching between 8-bit and 16-bit bus modes. After program execution starts, an 8-bit or 16-bit address space can be set for each area, depending on the bus controller setting. If 16-bit access is selected for any one area, 16-bit bus mode is set; if 8-bit access is selected for all areas, 8-bit bus mode is set.

Note that the functions of each pin depend on the operating mode.

The H8S/2633 Series can be used only in modes 4 to 7. This means that the mode pins must be set to select one of these modes. Do not change the inputs at the mode pins during operation.

### 3.1.2 Register Configuration

The H8S/2633 Series has a mode control register (MDCR) that indicates the inputs at the mode pins (MD2 to MD0), and a system control register (SYSCR) that controls the operation of the H8S/2633 Series. Table 3-2 summarizes these registers.

**Table 3-2 MCU Registers**

Name	Abbreviation	R/W	Initial Value	Address*
Mode control register	MDCR	R/W	Undetermined	H'FDE7
System control register	SYSCR	R/W	H'01	H'FDE5
Pin function control register	PFCR	R/W	H'0D/H'00	H'FDEB

Note: \* Lower 16 bits of the address.

## 3.2 Register Descriptions

### 3.2.1 Mode Control Register (MDCR)

Bit	:	7	6	5	4	3	2	1	0
		—	—	—	—	—	MDS2	MDS1	MDS0
Initial value	:	1	0	0	0	0	—*	—*	—*
R/W	:	R/W	—	—	—	—	R	R	R

Note: \* Determined by pins MD2 to MD0.

MDCR is an 8-bit register that indicates the current operating mode of the H8S/2633 Series.

**Bit 7—Reserved:** Only 1 should be written to this bit.

**Bits 6 to 3—Reserved:** These bits always read as 0 and cannot be modified.

**Bits 2 to 0—Mode Select 2 to 0 (MDS2 to MDS0):** These bits indicate the input levels at pins MD2 to MD0 (the current operating mode). Bits MDS2 to MDS0 correspond to MD2 to MD0. MDS2 to MDS0 are read-only bits—they cannot be written to. The mode pin (MD2 to MD0) input levels are latched into these bits when MDCR is read. These latches are cancelled by a power-on reset, but maintained by a manual reset.

### 3.2.2 System Control Register (SYSCR)

Bit	:	7	6	5	4	3	2	1	0
		MACS	—	INTM1	INTM0	NMIEG	MRESE	—	RAME
Initial value	:	0	0	0	0	0	0	0	1
R/W	:	R/W	—	R/W	R/W	R/W	R/W	—	R/W

SYSCR is an 8-bit readable-writable register that selects saturating or non-saturating calculation for the MAC instruction, selects the interrupt control mode, selects the detected edge for NMI, enables or disables  $\overline{\text{MRES}}$  pin input, and enables or disables on-chip RAM.

SYSCR is initialized to H'01 by a power-on reset and in hardware standby mode. MACS, INTM1, INTM0, NMIEG, and RAME bits are initialized in manual reset mode, but the MRESE bit is not initialized. SYSCR is not initialized in software standby mode.

**Bit 7—MAC Saturation (MACS):** Selects either saturating or non-saturating calculation for the MAC instruction.

#### Bit 7

MACS	Description
0	Non-saturating calculation for MAC instruction (Initial value)
1	Saturating calculation for MAC instruction

**Bit 6—Reserved:** This bit always read as 0 and cannot be modified.

**Bits 5 and 4—Interrupt Control Mode 1 and 0 (INTM1, INTM0):** These bits select the control mode of the interrupt controller. For details of the interrupt control modes, see section 5.4.1, Interrupt Control Modes and Interrupt Operation.

Bit 5	Bit 4	Interrupt Control Mode	Description
INTM1	INTM0		
0	0	0	Control of interrupts by I bit (Initial value)
	1	—	Setting prohibited
1	0	2	Control of interrupts by I2 to I0 bits and IPR
	1	—	Setting prohibited

**Bit 3—NMI Edge Select (NMIEG):** Selects the valid edge of the NMI interrupt input.

**Bit 3**

NMIEG	Description
0	An interrupt is requested at the falling edge of NMI input (Initial value)
1	An interrupt is requested at the rising edge of NMI input

**Bit 2—Manual Reset Selection Bit (MRESE):** Enables or disables manual reset input. It is possible to set the P74/TM02/ $\overline{\text{MRES}}$  pin to the manual reset input ( $\overline{\text{MRES}}$ ).

Table 3-3 shows the relationship between the  $\overline{\text{MRES}}$  pin power-on reset and manual reset.

**Bit 2**

MRESE	Description
0	Disables manual reset. Possible to use P74/TM02*/ $\overline{\text{MRES}}$ pin as P74/TM02* input pin. (Initial value)
1	Enables manual reset. Possible to use P74/TM02*/ $\overline{\text{MRES}}$ pin as $\overline{\text{MRES}}$ input pin.

Note: \* This function is not available in the H8S/2695.

**Table 3-3 Relationship Between Power-On Reset and Manual Reset**

RES	Pin		Reset Type
	RES	MRES	
0	*		Power-on reset (Initial state)
1	0		Manual reset
1	1		Operation state

\*: Don't care

**Bit 1—Reserved:** This bit always read as 0 and cannot be modified.

**Bit 0—RAM Enable (RAME):** Enables or disables the on-chip RAM. The RAME bit is initialized when the reset status is released. It is not initialized in software standby mode.

**Bit 0**

RAME	Description
0	On-chip RAM is disabled
1	On-chip RAM is enabled (Initial value)

Note: When the DTC\* is used, the RAME bit must be set to 1.

\* The DTC function is not available in the H8S/2695.



### 3.2.3 Pin Function Control Register (PFCR)

Bit	:	7	6	5	4	3	2	1	0
		CSS07	CSS36	BUZZE	LCASS	AE3	AE2	AE1	AE0
Initial value	:	0	0	0	0	1/0	1/0	0	1/0
R/W	:	R/W	R/W	R/W	R/W	R/W	R/W	R/W	R/W

PFCR is an 8-bit readable-writable register that carries out CS selection control for PG4 and PG1 pins, LCAS selection control for PF2 and PF6 pins, and address output control during extension modes with ROM.

PFCR is initialized by H'0D/H'00 by a power-on reset or a hardware standby mode. The immediately previous state is maintained in manual reset or software standby mode.

**Bit 7— $\overline{\text{CS0}}/\overline{\text{CS7}}$  Select (CSS07):** Selects the CS output content for PG4 pin. In modes 4 to 6, the selected CS is output by setting the corresponding DDR to 1.

#### Bit 7

CSS07	Description
0	Select $\overline{\text{CS0}}$ (Initial value)
1	Select $\overline{\text{CS7}}$

**Bit 6— $\overline{\text{CS3}}/\overline{\text{CS6}}$  Select (CSS36):** Selects the CS output content for PG1 pin. In modes 4 to 6, the selected CS is output by setting the corresponding DDR to 1.

#### Bit 6

CSS36	Description
0	Select $\overline{\text{CS3}}$ (Initial value)
1	Select $\overline{\text{CS6}}$

**Bit 5—BUZZ Output Enable (BUZZE)\*:** Disables/enables BUZZ output of PF1 pin. Input clock of WDT1 selected by PSS, CKS2 to CKS0 bits is output as a BUZZ signal.

**Bit 5**

<b>BUZZE</b>	<b>Description</b>	
0	Functions as PF1 input pin	(Initial value)
1	Functions as BUZZ output pin	

Note: \* This function is not available in the H8S/2695. This bit should not be set to 1.

**Bit 4—LCAS Output Pin Selection Bit (LCASS)\*:** Selects the LCAS signal output pin.

**Bit 4**

<b>LCASS</b>	<b>Description</b>	
0	Outputs LCAS signal from PF2	(Initial value)
1	Outputs LCAS signal from PF6	

Note: \* This function is not available in the H8S/2695. This bit should not be set to 1.

**Bits 3 to 0—Address Output Enable 3 to 0 (AE3–AE0):** These bits select enabling or disabling of address outputs A8 to A23 in ROMless expanded mode and modes with ROM. When a pin is enabled for address output, the address is output regardless of the corresponding DDR setting. When a pin is disabled for address output, it becomes an output port when the corresponding DDR bit is set to 1.

Bit 3	Bit 2	Bit 1	Bit 0	Description
AE3	AE2	AE1	AE0	
0	0	0	0	A8–A23 address output disabled (Initial value*)
			1	A8 address output enabled; A9–A23 address output disabled
		1	0	A8, A9 address output enabled; A10–A23 address output disabled
			1	A8–A10 address output enabled; A11–A23 address output disabled
	1	0	0	A8–A11 address output enabled; A12–A23 address output disabled
			1	A8–A12 address output enabled; A13–A23 address output disabled
		1	0	A8–A13 address output enabled; A14–A23 address output disabled
			1	A8–A14 address output enabled; A15–A23 address output disabled
1	0	0	0	A8–A15 address output enabled; A16–A23 address output disabled
			1	A8–A16 address output enabled; A17–A23 address output disabled
		1	0	A8–A17 address output enabled; A18–A23 address output disabled
			1	A8–A18 address output enabled; A19–A23 address output disabled
	1	0	0	A8–A19 address output enabled; A20–A23 address output disabled
			1	A8–A20 address output enabled; A21–A23 address output disabled (Initial value*)
		1	0	A8–A21 address output enabled; A22, A23 address output disabled
			1	A8–A23 address output enabled

Note: \* In expanded mode with ROM, bits AE3 to AE0 are initialized to B'0000.

In ROMless expanded mode, bits AE3 to AE0 are initialized to B'1101.

Address pins A0 to A7 are made address outputs by setting the corresponding DDR bits to 1.

## **3.3 Operating Mode Descriptions**

### **3.3.1 Mode 4**

The CPU can access a 16-Mbyte address space in advanced mode. The on-chip ROM is disabled.

Ports 1, A, B, and C, function as an address bus, ports D and E function as a data bus, and part of port F carries bus control signals.

The initial bus mode after a reset is 16 bits, with 16-bit access to all areas. However, note that if 8-bit access is designated by the bus controller for all areas, the bus mode switches to 8 bits.

### **3.3.2 Mode 5**

The CPU can access a 16-Mbyte address space in advanced mode. The on-chip ROM is disabled.

Ports 1, A, B, and C, function as an address bus, ports D and E function as a data bus, and part of port F carries bus control signals.

The initial bus mode after a reset is 8 bits, with 8-bit access to all areas. However, note that if 16-bit access is designated by the bus controller for any area, the bus mode switches to 16 bits and port E becomes a data bus.

### **3.3.3 Mode 6**

The CPU can access a 16-Mbyte address space in advanced mode. The on-chip ROM is enabled.

Ports 1, A, B, and C, function as input port pins immediately after a reset. Address output can be performed by setting the corresponding DDR (data direction register) bits to 1.

Port D function as a data bus, and part of port F carries data bus signals.

The initial bus mode after a reset is 8 bits, with 8-bit access to all areas. However, note that if 16-bit access is designated by the bus controller for any area, the bus mode switches to 16 bits and port E becomes a data bus.

### **3.3.4 Mode 7**

The CPU can access a 16-Mbyte address space in advanced mode. The on-chip ROM is enabled, but external addresses cannot be accessed.

All I/O ports are available for use as input-output ports.

### 3.4 Pin Functions in Each Operating Mode

The pin functions of ports A to F vary depending on the operating mode. Table 3-3 shows their functions in each operating mode.

**Table 3-3 Pin Functions in Each Mode**

Port		Mode 4	Mode 5	Mode 6	Mode 7
Port 1	P1 <sub>0</sub>	P/A*	P/A*	P*/A	P
	P1 <sub>1</sub> to P1 <sub>3</sub>	P*/A	P*/A	P*/A	P
Port A	PA <sub>4</sub> to PA <sub>0</sub>	A	A	P*/A	P
Port B		A	A	P*/A	P
Port C		A	A	P*/A	P
Port D		D	D	D	P
Port E		P/D*	P*/D	P*/D	P
Port F	PF <sub>7</sub>	P/C*	P/C*	P/C*	P*/C
	PF <sub>6</sub> to PF <sub>4</sub>	C	C	C	P
	PF <sub>3</sub>	P/C*	P*/C	P*/C	
	PF <sub>2</sub> to PF <sub>0</sub>	P*/C	P*/C	P*/C	
Port G	PG <sub>4</sub>	C	C	P*/C	P
	PG <sub>3</sub> to PG <sub>0</sub>	P*/C	P*/C	P*/C	P

#### Legend

P: I/O port

A: Address bus output

D: Data bus I/O

C: Control signals, clock I/O

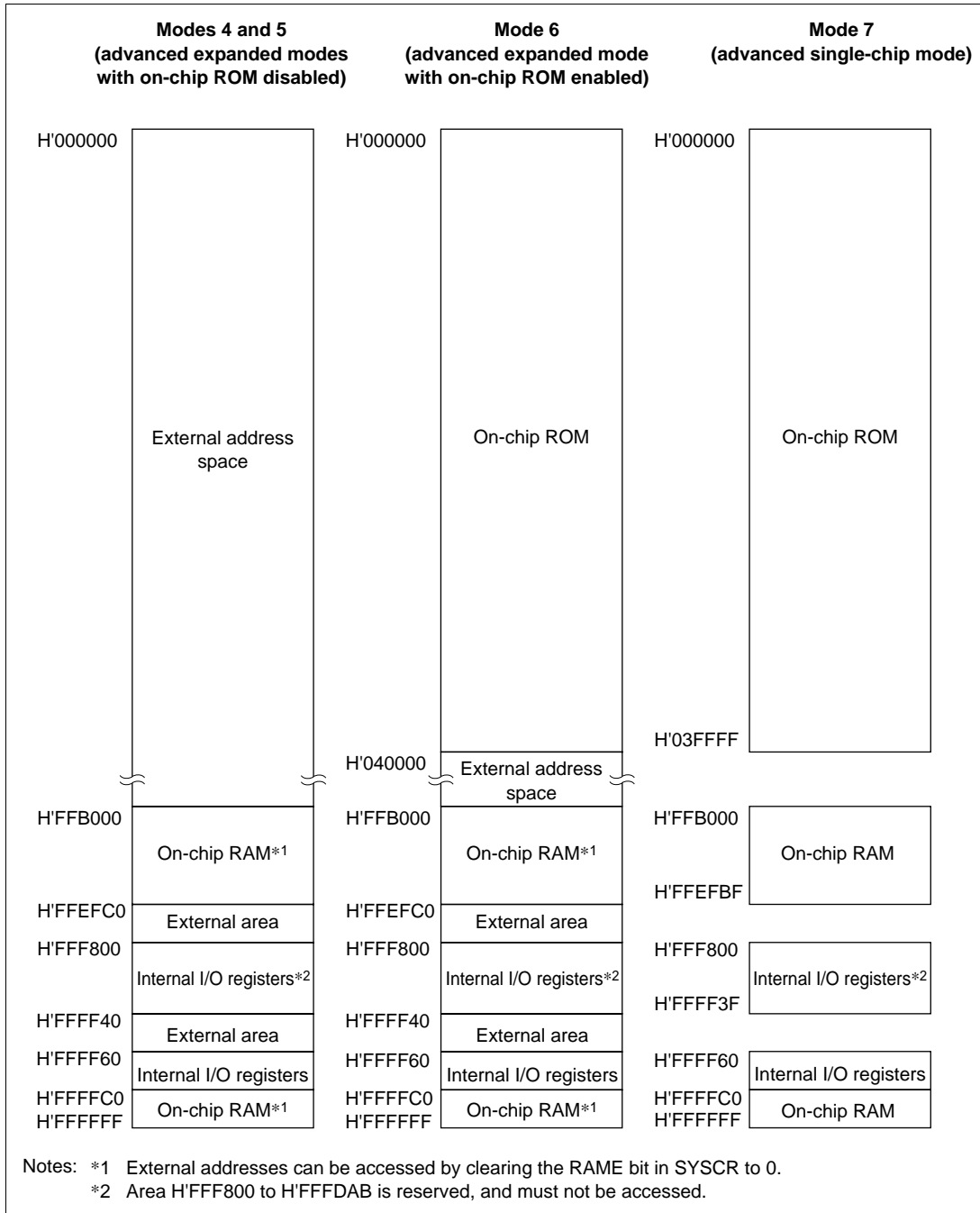
\*: After reset

### 3.5 Address Map in Each Operating Mode

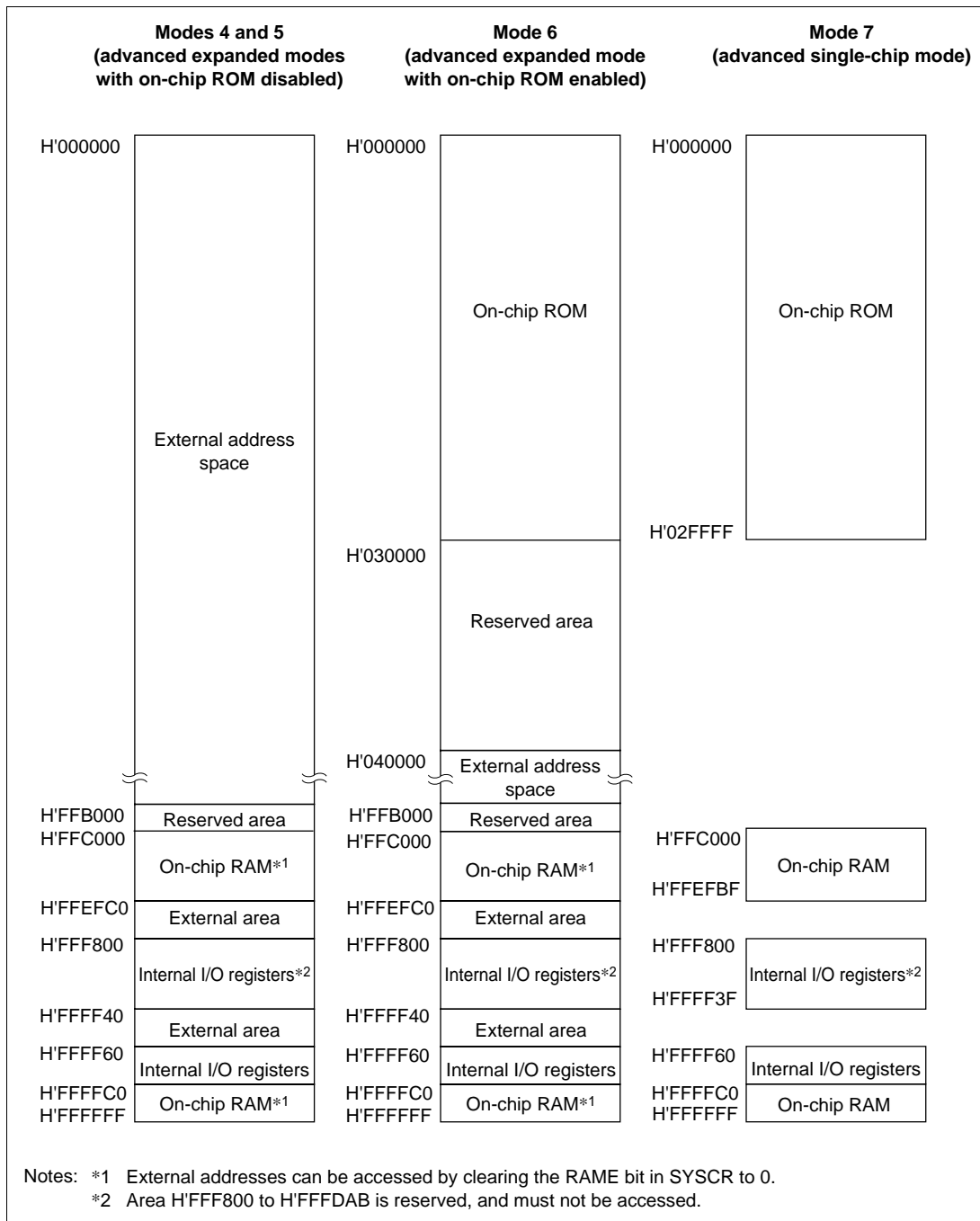
An address map of the H8S/2633, H8S/2633R are shown in figure 3-1, and an address map of the H8S/2632 in figure 3-2, and an address map of the H8S/2631 in figure 3-3, and an address map of the H8S/2695 in figure 3-4.

The address space is 16 Mbytes in modes 4 to 7 (advanced modes).

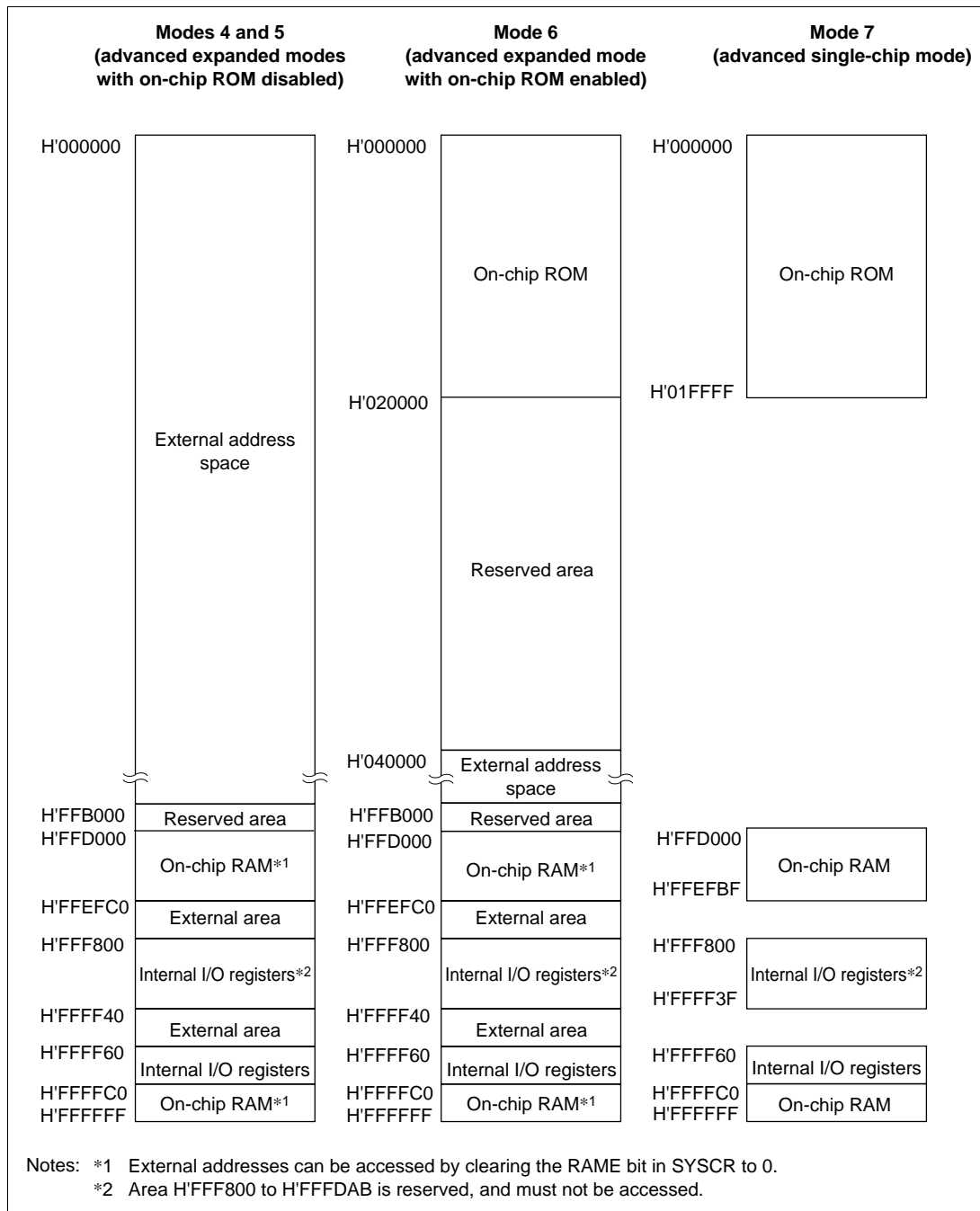
The address space is divided into eight areas for modes 4 to 7. For details, see section 7, Bus Controller.



**Figure 3-1 Memory Map in Each Operating Mode in the H8S/2633, H8S/2633R**

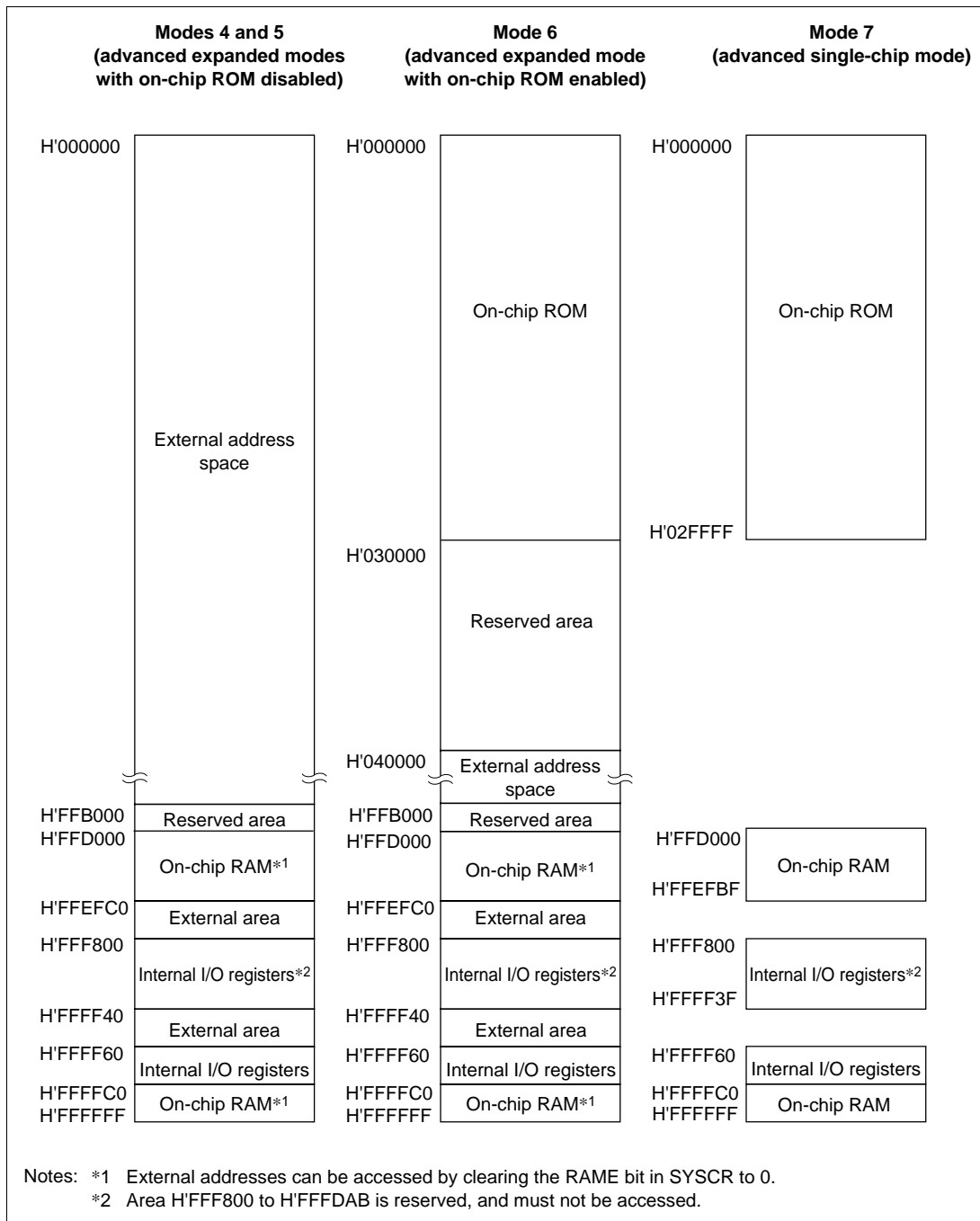


**Figure 3-2 Memory Map in Each Operating Mode in the H8S/2632**



**Figure 3-3 Memory Map in Each Operating Mode in the H8S/2631**





**Figure 3-4 Memory Map in Each Operating Mode in the H8S/2695**



## Section 4 Exception Handling

### 4.1 Overview

#### 4.1.1 Exception Handling Types and Priority

As table 4-1 indicates, exception handling may be caused by a reset, direct transition, trap instruction, or interrupt. Exception handling is prioritized as shown in table 4-1. If two or more exceptions occur simultaneously, they are accepted and processed in order of priority. Trap instruction exceptions are accepted at all times, in the program execution state.

Exception handling sources, the stack structure, and the operation of the CPU vary depending on the interrupt control mode set by the INTM0 and INTM1 bits of SYSCR.

**Table 4-1 Exception Types and Priority**

Priority	Exception Type	Start of Exception Handling
High ↑ ↓ Low	Reset	Starts immediately after a low-to-high transition at the $\overline{\text{RES}}$ pin or MRES pin, or when the watchdog overflows. The CPU enters the power-on reset state when the $\overline{\text{RES}}$ pin is low, and the manual reset state when the $\overline{\text{MRES}}$ pin is low
	Trace* <sup>1</sup>	Starts when execution of the current instruction or exception handling ends, if the trace (T) bit is set to 1
	Direct transition	Starts when a direct transition occurs due to execution of a SLEEP instruction
	Interrupt	Starts when execution of the current instruction or exception handling ends, if an interrupt request has been issued* <sup>2</sup>
Low	Trap instruction (TRAPA)* <sup>3</sup>	Started by execution of a trap instruction (TRAPA)

Notes: \*1 Traces are enabled only in interrupt control mode 2. Trace exception handling is not executed after execution of an RTE instruction.

\*2 Interrupt detection is not performed on completion of ANDC, ORC, XORC, or LDC instruction execution, or on completion of reset exception handling.

\*3 Trap instruction exception handling requests are accepted at all times in program execution state.

### 4.1.2 Exception Handling Operation

Exceptions originate from various sources. Trap instructions and interrupts are handled as follows:

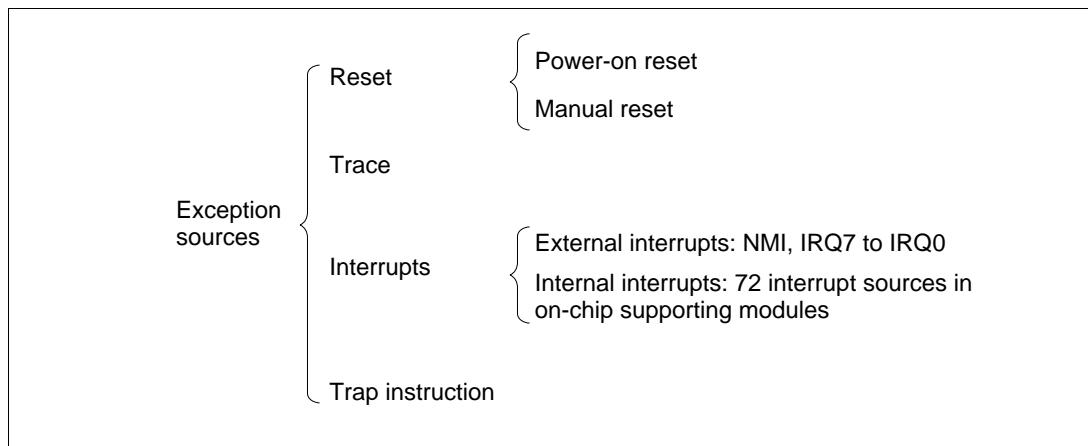
1. The program counter (PC), condition code register (CCR), and extended register (EXR) are pushed onto the stack.
2. The interrupt mask bits are updated. The T bit is cleared to 0.
3. A vector address corresponding to the exception source is generated, and program execution starts from that address.

For a reset exception, steps 2 and 3 above are carried out.

### 4.1.3 Exception Vector Table

The exception sources are classified as shown in figure 4-1. Different vector addresses are assigned to different exception sources.

Table 4-2 lists the exception sources and their vector addresses.



**Figure 4-1 Exception Sources**

**Table 4-2 Exception Vector Table**

Exception Source	Vector Number	Vector Address* <sup>1</sup>	
		Advanced Mode	
Power-on reset	0	H'0000 to H'0003	
Manual reset* <sup>3</sup>	1	H'0004 to H'0007	
Reserved for system use	2	H'0008 to H'000B	
	3	H'000C to H'000F	
	4	H'0010 to H'0013	
Trace	5	H'0014 to H'0017	
Direct transition* <sup>3</sup>	6	H'0018 to H'001B	
External interrupt      NMI	7	H'001C to H'001F	
Trap instruction (4 sources)	8	H'0020 to H'0023	
	9	H'0024 to H'0027	
	10	H'0028 to H'002B	
	11	H'002C to H'002F	
Reserved for system use	12	H'0030 to H'0033	
	13	H'0034 to H'0037	
	14	H'0038 to H'003B	
	15	H'003C to H'003F	
External interrupt	IRQ0	16	H'0040 to H'0043
	IRQ1	17	H'0044 to H'0047
	IRQ2	18	H'0048 to H'004B
	IRQ3	19	H'004C to H'004F
	IRQ4	20	H'0050 to H'0053
	IRQ5	21	H'0054 to H'0057
	IRQ6	22	H'0058 to H'005B
	IRQ7	23	H'005C to H'005F
Internal interrupt* <sup>2</sup>	24	H'0060 to H'0063	
	127	H'01FC to H'01FF	

Notes: \*1 Lower 16 bits of the address.

\*2 For details of internal interrupt vectors, see section 5.3.3, Interrupt Exception Handling Vector Table.

\*3 See section 24.11, Direct Transitions, for details on direct transitions.  
This function is not available in the H8S/2695.

## 4.2 Reset

### 4.2.1 Overview

A reset has the highest exception handling priority. There are two kinds of reset: a power-on reset executed via the  $\overline{\text{RES}}$  pin, and a manual reset executed via the  $\overline{\text{MRES}}$  pin.

When the  $\overline{\text{RES}}$  or  $\overline{\text{MRES}}$  pin\* goes low, currently executing processing is halted and the chip enters the reset state. A reset initializes the internal state of the CPU and the registers of on-chip supporting modules. Immediately after a reset, interrupt control mode 0 is set.

Reset exception handling starts when the  $\overline{\text{RES}}$  or  $\overline{\text{MRES}}$  pin\* changes from low to high.

The reset state can also be entered in the event of watchdog timer overflow. For details see section 15, Watchdog Timer.

Note: \*  $\overline{\text{MRES}}$  pin in the case of a manual reset.

### 4.2.2 Types of Reset

There are two types of reset: power-on reset and manual reset.

Table 4-3 shows the types of reset. When turning power on, do so as a power-on reset.

Both power-on reset and manual reset initialize the internal state of the CPU. In a power-on reset, all of the registers of the built-in vicinity modules are initialized, while in a manual reset, the registers of the built-in vicinity models except for bus controllers and I/O ports are initialized. The states of the bus controllers and I/O ports are maintained.

During a manual reset built-in vicinity modules are initialized, and ports used as input pins for built-in vicinity modules switch to the input ports controlled by DDR and DR.

If using manual reset, set the MRESE bit to 1 beforehand, thereby enabling manual resets.

See section 3.2.2, System Control Register (SYSCR) for settings of the MRESE bit.

There are also power-on resets and manual resets as the two types of reset carried out by the watchdog timer.

**Table 4-3 Types of Reset**

Type	Conditions for Transition to Reset		Internal State	
	$\overline{\text{MRES}}$	$\overline{\text{RES}}$	CPU	Built-in vicinity module
Power-on reset	*	Low	Initialization	Initialization
Manual reset	Low	High	Initialization	Initialization except for bus controller and I/O port

\*: Don't Care

### 4.2.3 Reset Sequence

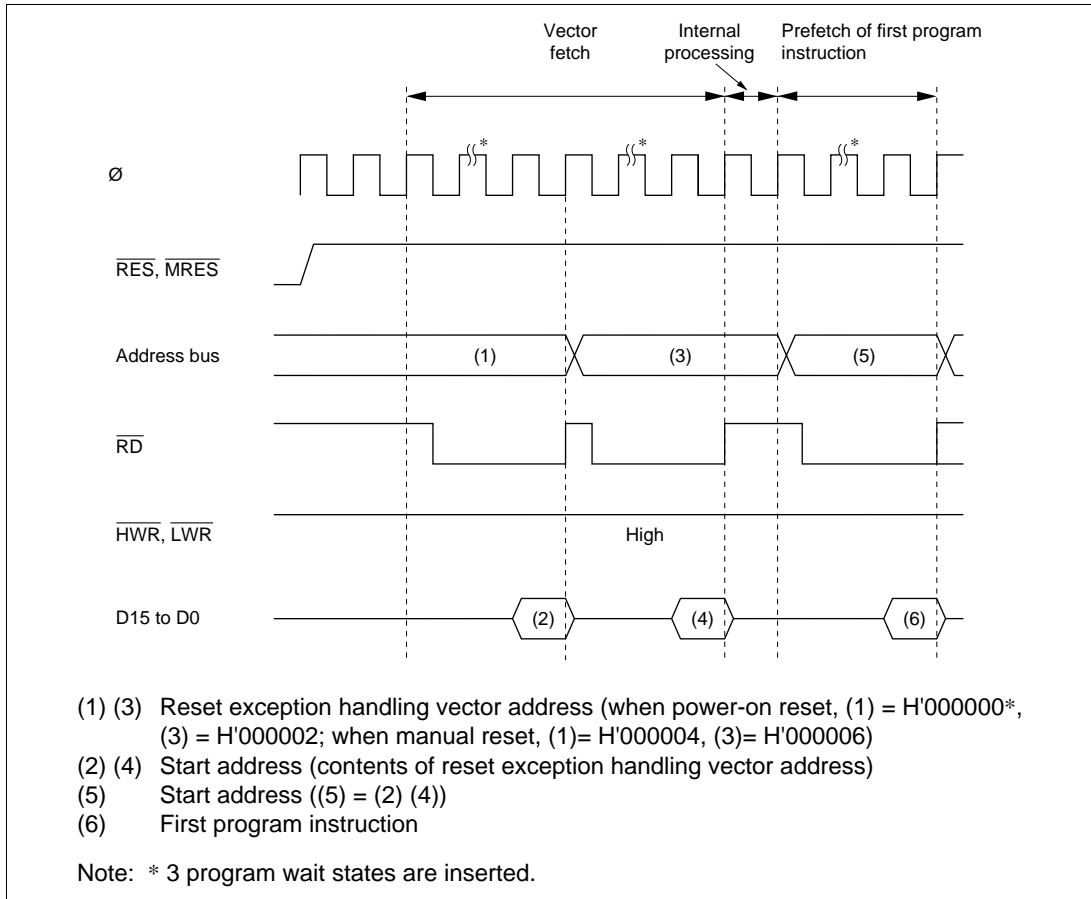
This LSI enters reset state when the  $\overline{\text{RES}}$  pin or  $\overline{\text{MRES}}$  pin goes low.

To ensure that this LSI is reset, hold the  $\overline{\text{RES}}$  pin or the  $\overline{\text{MRES}}$  pin low for at least 20 ms at power-up. To reset during operation, hold the  $\overline{\text{RES}}$  pin or the  $\overline{\text{MRES}}$  pin low for at least 20 states.

When the  $\overline{\text{RES}}$  pin or the  $\overline{\text{MRES}}$  pin goes high after being held low for the necessary time, this LSI starts reset exception handling as follows.

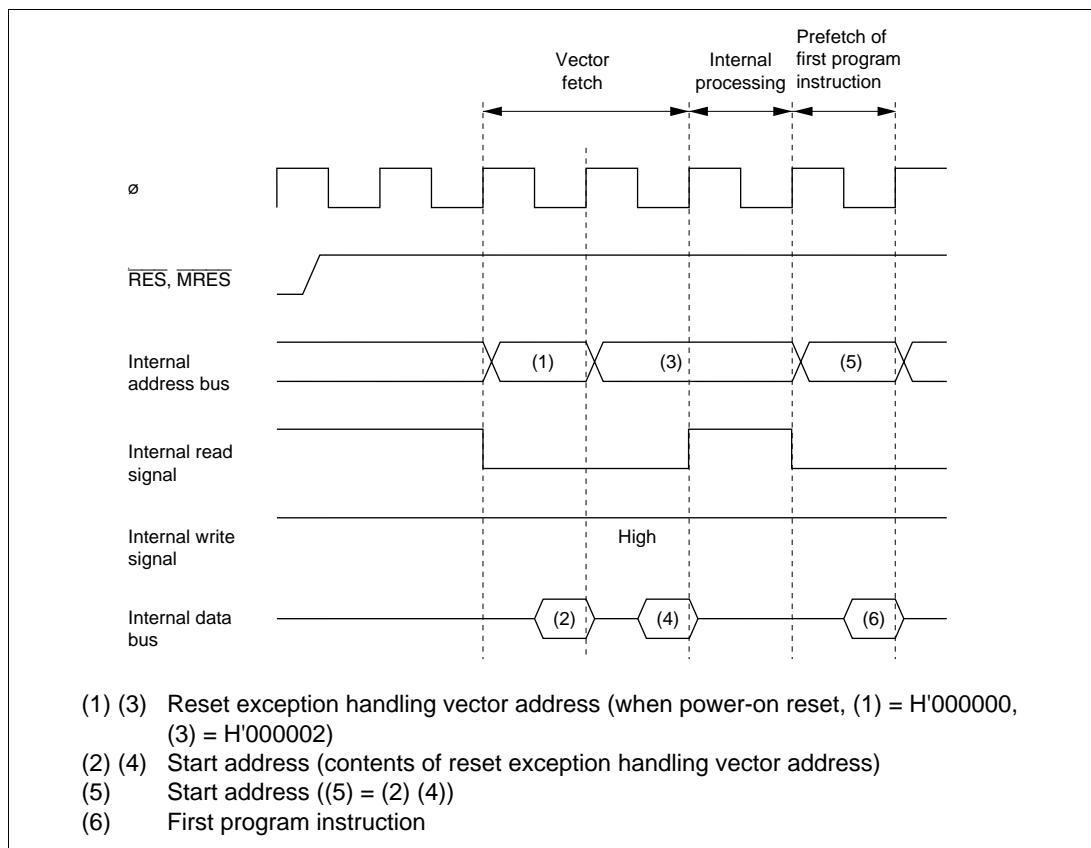
1. The internal state of the CPU and the registers of the on-chip supporting modules are initialized, the T bit is cleared to 0 in EXR, and the I bit is set to 1 in EXR and CCR.
2. The reset exception handling vector address is read and transferred to the PC, and program execution starts from the address indicated by the PC.

Figures 4-2 and 4-3 show examples of the reset sequence.



**Figure 4-2 Reset Sequence (Modes 4 and 5)**





**Figure 4-3 Reset Sequence (Modes 6 and 7)**

#### 4.2.4 Interrupts after Reset

If an interrupt is accepted after a reset but before the stack pointer (SP) is initialized, the PC and CCR will not be saved correctly, leading to a program crash. To prevent this, all interrupt requests, including NMI, are disabled immediately after a reset. Since the first instruction of a program is always executed immediately after the reset state ends, make sure that this instruction initializes the stack pointer (example: MOV.L #xx: 32, SP).

#### 4.2.5 State of On-Chip Supporting Modules after Reset Release

After reset release, MSTPCRA to MSTPCRC are initialized to H'3F, H'FF, and H'FF, respectively, and all modules except the DMAC\* and DTC\*, enter module stop mode. Consequently, on-chip supporting module registers cannot be read or written to. Register reading and writing is enabled when module stop mode is exited.

Note: \* DMAC and DTC functions are not available in the H8S/2695.

### 4.3 Traces

Traces are enabled in interrupt control mode 2. Trace mode is not activated in interrupt control mode 0, irrespective of the state of the T bit. For details of interrupt control modes, see section 5, Interrupt Controller.

If the T bit in EXR is set to 1, trace mode is activated. In trace mode, a trace exception occurs on completion of each instruction.

Trace mode is canceled by clearing the T bit in EXR to 0. It is not affected by interrupt masking.

Table 4-4 shows the state of CCR and EXR after execution of trace exception handling.

Interrupts are accepted even within the trace exception handling routine.

The T bit saved on the stack retains its value of 1, and when control is returned from the trace exception handling routine by the RTE instruction, trace mode resumes.

Trace exception handling is not carried out after execution of the RTE instruction.

**Table 4-4 Status of CCR and EXR after Trace Exception Handling**

Interrupt Control Mode	CCR		EXR	
	I	UI	I2 to I0	T
0	Trace exception handling cannot be used.			
2	1	—	—	0

**Legend**

1: Set to 1

0: Cleared to 0

—: Retains value prior to execution

## 4.4 Interrupts

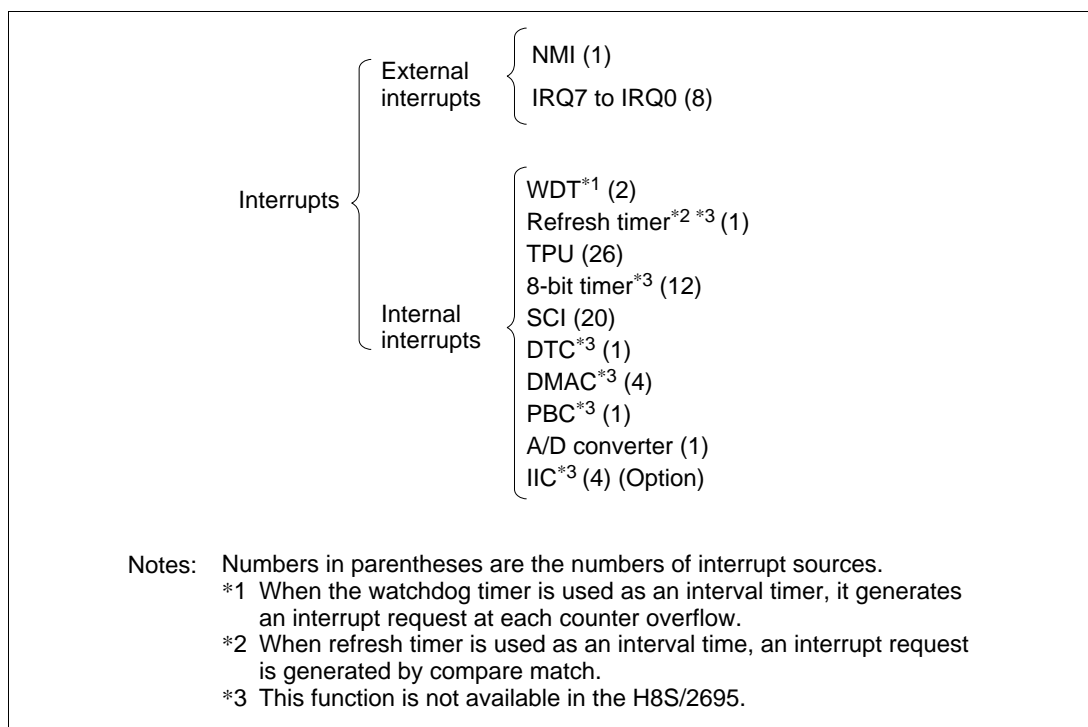
Interrupt exception handling can be requested by nine external sources (NMI, IRQ7 to IRQ0) and 72 internal sources in the on-chip supporting modules. Figure 4-4 classifies the interrupt sources and the number of interrupts of each type.

The on-chip supporting modules that can request interrupts include the watchdog timer (WDT), 16-bit timer-pulse unit (TPU), 8-bit timer\*, serial communication interface (SCI), data transfer controller (DTC)\*, DMA controller (DMAC)\*, PC break controller (PBC)\*, A/D converter, and I<sup>2</sup>C bus interface (IIC)\*. Each interrupt source has a separate vector address.

NMI is the highest-priority interrupt. Interrupts are controlled by the interrupt controller. The interrupt controller has two interrupt control modes and can assign interrupts other than NMI to eight priority/mask levels to enable multiplexed interrupt control.

For details of interrupts, see section 5, Interrupt Controller.

Note: \* This function is not available in the H8S/2695.



**Figure 4-4 Interrupt Sources and Number of Interrupts**

## 4.5 Trap Instruction

Trap instruction exception handling starts when a TRAPA instruction is executed. Trap instruction exception handling can be executed at all times in the program execution state.

The TRAPA instruction fetches a start address from a vector table entry corresponding to a vector number from 0 to 3, as specified in the instruction code.

Table 4-5 shows the status of CCR and EXR after execution of trap instruction exception handling.

**Table 4-5 Status of CCR and EXR after Trap Instruction Exception Handling**

Interrupt Control Mode	CCR		EXR	
	I	UI	I2 to I0	T
0	1	—	—	—
2	1	—	—	0

### Legend

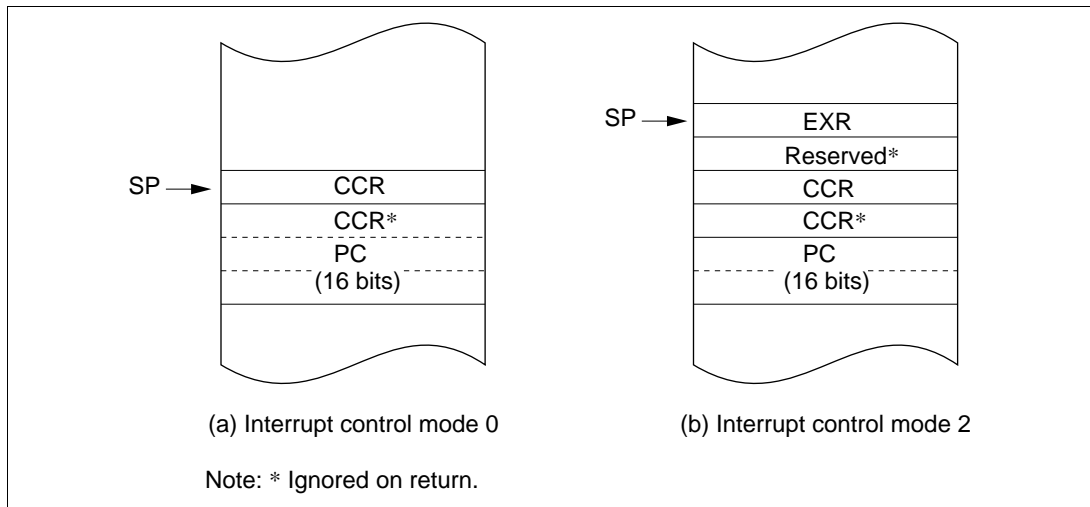
1: Set to 1

0: Cleared to 0

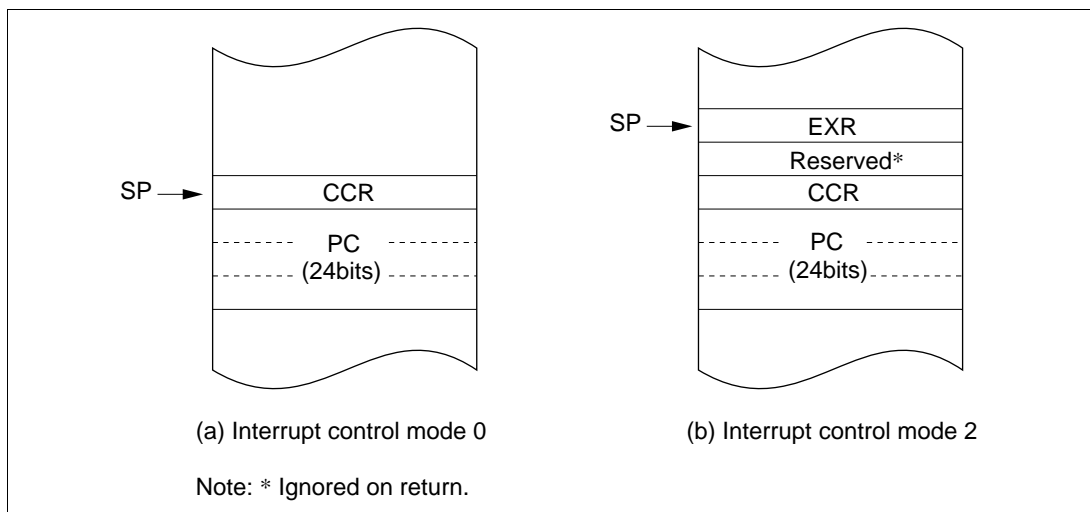
—: Retains value prior to execution

## 4.6 Stack Status after Exception Handling

Figure 4-5 shows the stack after completion of trap instruction exception handling and interrupt exception handling.



**Figure 4-5 (1) Stack Status after Exception Handling (Normal Modes: Not Available in the H8S/2633 Series)**



**Figure 4-5 (2) Stack Status after Exception Handling (Advanced Modes)**

## 4.7 Notes on Use of the Stack

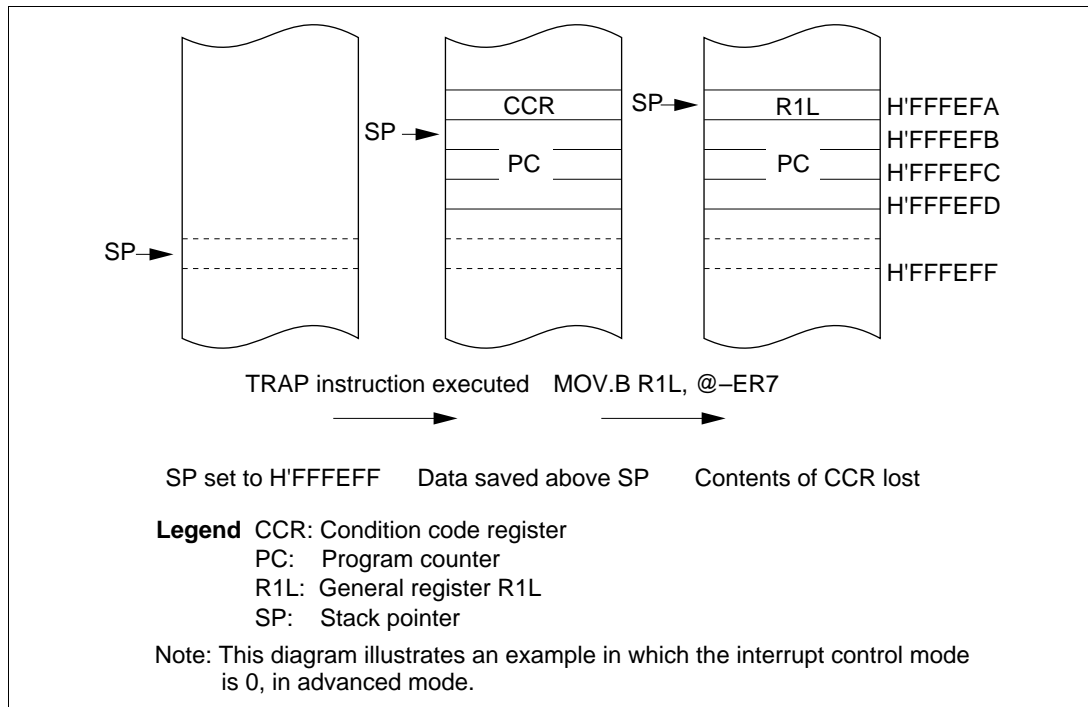
When accessing word data or longword data, the H8S/2633 Series assumes that the lowest address bit is 0. The stack should always be accessed by word transfer instruction or longword transfer instruction, and the value of the stack pointer (SP, ER7) should always be kept even. Use the following instructions to save registers:

```
PUSH.W  Rn    (or MOV.W Rn,  @-SP)
PUSH.L  ERn   (or MOV.L ERn, @-SP)
```

Use the following instructions to restore registers:

```
POP.W   Rn    (or MOV.W @SP+, Rn)
POP.L   ERn   (or MOV.L @SP+, ERn)
```

Setting SP to an odd value may lead to a malfunction. Figure 4-6 shows an example of what happens when the SP value is odd.



**Figure 4-6 Operation when SP Value is Odd**

# Section 5 Interrupt Controller

## 5.1 Overview

### 5.1.1 Features

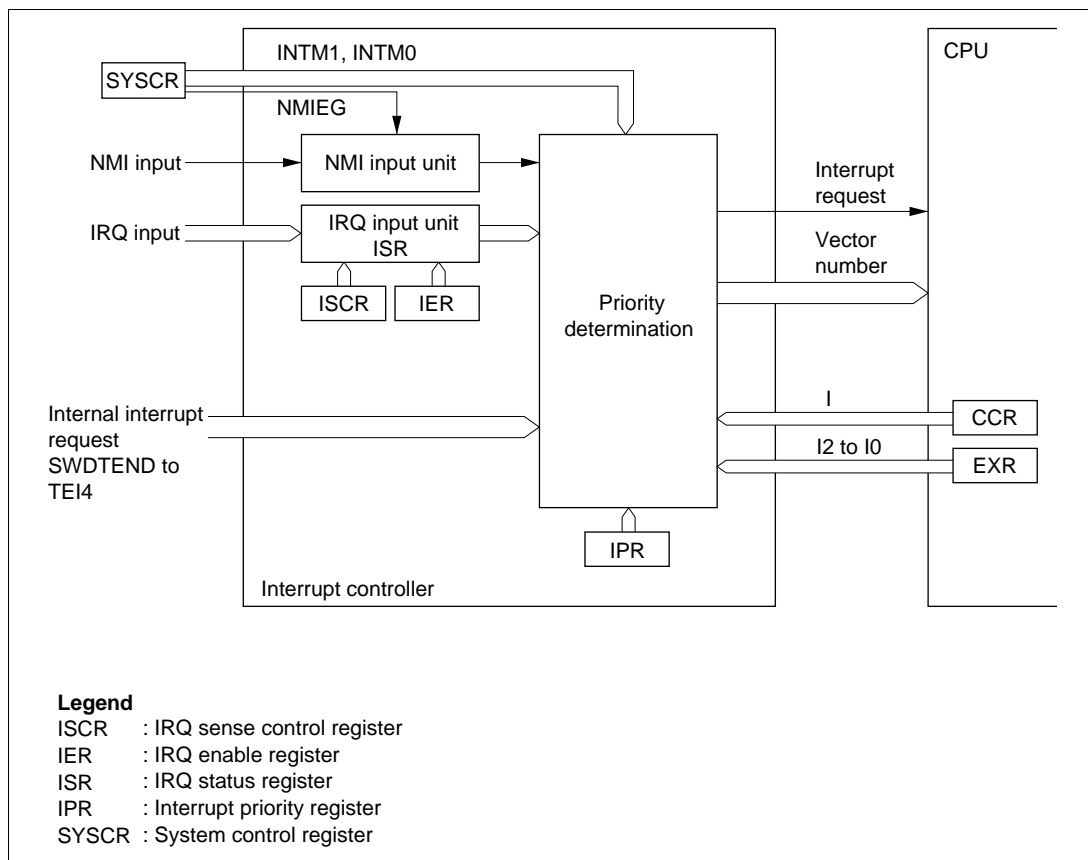
The H8S/2633 Series controls interrupts by means of an interrupt controller. The interrupt controller has the following features:

- Two interrupt control modes
  - Any of two interrupt control modes can be set by means of the INTM1 and INTM0 bits in the system control register (SYSCR)
- Priorities settable with IPR
  - An interrupt priority register (IPR) is provided for setting interrupt priorities. Eight priority levels can be set for each module for all interrupts except NMI
  - NMI is assigned the highest priority level of 8, and can be accepted at all times
- Independent vector addresses
  - All interrupt sources are assigned independent vector addresses, making it unnecessary for the source to be identified in the interrupt handling routine
- Nine external interrupts
  - NMI is the highest-priority interrupt, and is accepted at all times. Rising edge or falling edge can be selected for NMI
  - Falling edge, rising edge, or both edge detection, or level sensing, can be selected for IRQ7 to IRQ0
- DTC\* and DMAC\* control
  - DTC and DMAC activation is performed by means of interrupts

Note: \* This function is not available in the H8S/2695.

### 5.1.2 Block Diagram

A block diagram of the interrupt controller is shown in Figure 5-1.



**Figure 5-1 Block Diagram of Interrupt Controller**



### 5.1.3 Pin Configuration

Table 5-1 summarizes the pins of the interrupt controller.

**Table 5-1 Interrupt Controller Pins**

Name	Symbol	I/O	Function
Nonmaskable interrupt	NMI	Input	Nonmaskable external interrupt; rising or falling edge can be selected
External interrupt requests 7 to 0	$\overline{\text{IRQ}}7$ to $\overline{\text{IRQ}}0$	Input	Maskable external interrupts; rising, falling, or both edges, or level sensing, can be selected

### 5.1.4 Register Configuration

Table 5-2 summarizes the registers of the interrupt controller.

**Table 5-2 Interrupt Controller Registers**

Name	Abbreviation	R/W	Initial Value	Address* <sup>1</sup>
System control register	SYSCR	R/W	H'01	H'FDE5
IRQ sense control register H	ISCRH	R/W	H'00	H'FE12
IRQ sense control register L	ISCR L	R/W	H'00	H'FE13
IRQ enable register	IER	R/W	H'00	H'FE14
IRQ status register	ISR	R/(W)* <sup>2</sup>	H'00	H'FE15
Interrupt priority register A	IPRA	R/W	H'77	H'FEC0
Interrupt priority register B	IPRB	R/W	H'77	H'FEC1
Interrupt priority register C	IPRC	R/W	H'77	H'FEC2
Interrupt priority register D	IPRD	R/W	H'77	H'FEC3
Interrupt priority register E	IPRE	R/W	H'77	H'FEC4
Interrupt priority register F	IPRF	R/W	H'77	H'FEC5
Interrupt priority register G	IPRG	R/W	H'77	H'FEC6
Interrupt priority register H	IPRH	R/W	H'77	H'FEC7
Interrupt priority register I	IPRI	R/W	H'77	H'FEC8
Interrupt priority register J	IPRJ	R/W	H'77	H'FEC9
Interrupt priority register K	IPRK	R/W	H'77	H'FECA
Interrupt priority register L	IPRL	R/W	H'77	H'FECB
Interrupt priority register O	IPRO	R/W	H'77	H'FECE

Notes: \*1 Lower 16 bits of the address.

\*2 Can only be written with 0 for flag clearing.

## 5.2 Register Descriptions

### 5.2.1 System Control Register (SYSCR)

Bit	:	7	6	5	4	3	2	1	0
		MACS	—	INTM1	INTM0	NMIEG	MRESE	—	RAME
Initial value	:	0	0	0	0	0	0	0	1
R/W	:	R/W	—	R/W	R/W	R/W	R/W	—	R/W

SYSCR is an 8-bit readable/writable register that selects the interrupt control mode, and the detected edge for NMI.

Only bits 5 to 3 are described here; for details of the other bits, see section 3.2.2, System Control Register (SYSCR).

SYSCR is initialized to H'01 by a power-on reset, manual reset, and in hardware standby mode. SYSCR is not initialized in software standby mode.

**Bits 5 and 4—Interrupt Control Mode 1 and 0 (INTM1, INTM0):** These bits select one of two interrupt control modes for the interrupt controller.

Bit 5	Bit 4	Interrupt Control Mode	Description
INTM1	INTM0		
0	0	0	Interrupts are controlled by I bit (Initial value)
	1	—	Setting prohibited
1	0	2	Interrupts are controlled by bits I2 to I0, and IPR
	1	—	Setting prohibited

**Bit 3—NMI Edge Select (NMIEG):** Selects the input edge for the NMI pin.

Bit 3	Description
NMIEG	
0	Interrupt request generated at falling edge of NMI input (Initial value)
1	Interrupt request generated at rising edge of NMI input

### 5.2.2 Interrupt Priority Registers A to L, O (IPRA to IPRL, IPRO)

Bit	:	7	6	5	4	3	2	1	0
		—	IPR6	IPR5	IPR4	—	IPR2	IPR1	IPR0
Initial value	:	0	1	1	1	0	1	1	1
R/W	:	—	R/W	R/W	R/W	—	R/W	R/W	R/W

The IPR registers are thirteen 8-bit readable/writable registers that set priorities (levels 7 to 0) for interrupts other than NMI.

The correspondence between IPR settings and interrupt sources is shown in table 5-3.

The IPR registers set a priority (level 7 to 0) for each interrupt source other than NMI.

The IPR registers are initialized to H'77 by a reset and in hardware standby mode.

**Bits 7 and 3—Reserved:** These bits are always read as 0 and cannot be modified.

**Table 5-3 Correspondence between Interrupt Sources and IPR Settings**

Register	Bits	
	6 to 4	2 to 0
IPRA	IRQ0	IRQ1
IPRB	IRQ2 IRQ3	IRQ4 IRQ5
IPRC	IRQ6 IRQ7	DTC*
IPRD	Watchdog timer 0	Refresh timer
IPRE	PC break*	A/D converter, watchdog timer 1*
IPRF	TPU channel 0	TPU channel 1
IPRG	TPU channel 2	TPU channel 3
IPRH	TPU channel 4	TPU channel 5
IPRI	8-bit timer channel 0*	8-bit timer channel 1*
IPRJ	DMAC	SCI channel 0
IPRK	SCI channel 1	SCI channel 2
IPRL	8-bit timer 2, 3*	IIC (Option)*
IPRO	SCI channel 3	SCI channel 4

Note: \* This function is not available in the H8S/2695.

As shown in table 5-3, multiple interrupts are assigned to one IPR. Setting a value in the range from H'0 to H'7 in the 3-bit groups of bits 6 to 4 and 2 to 0 sets the priority of the corresponding interrupt. The lowest priority level, level 0, is assigned by setting H'0, and the highest priority level, level 7, by setting H'7.

When interrupt requests are generated, the highest-priority interrupt according to the priority levels set in the IPR registers is selected. This interrupt level is then compared with the interrupt mask level set by the interrupt mask bits (I2 to I0) in the extend register (EXR) in the CPU, and if the priority level of the interrupt is higher than the set mask level, an interrupt request is issued to the CPU.

### 5.2.3 IRQ Enable Register (IER)

Bit	:	7	6	5	4	3	2	1	0
		IRQ7E	IRQ6E	IRQ5E	IRQ4E	IRQ3E	IRQ2E	IRQ1E	IRQ0E
Initial value	:	0	0	0	0	0	0	0	0
R/W	:	R/W	R/W	R/W	R/W	R/W	R/W	R/W	R/W

IER is an 8-bit readable/writable register that controls enabling and disabling of interrupt requests IRQ7 to IRQ0.

IER is initialized to H'00 by a reset and in hardware standby mode.

They are not initialized in software standby mode.

**Bits 7 to 0—IRQ7 to IRQ0 Enable (IRQ7E to IRQ0E):** These bits select whether IRQ7 to IRQ0 are enabled or disabled.

Bit n	IRQnE	Description
0		IRQn interrupts disabled (Initial value)
1		IRQn interrupts enabled

(n = 7 to 0)

## 5.2.4 IRQ Sense Control Registers H and L (ISCRH, ISCR L)

### ISCRH

Bit	:	15	14	13	12	11	10	9	8
		IRQ7SCB	IRQ7SCA	IRQ6SCB	IRQ6SCA	IRQ5SCB	IRQ5SCA	IRQ4SCB	IRQ4SCA
Initial value :		0	0	0	0	0	0	0	0
R/W	:	R/W	R/W	R/W	R/W	R/W	R/W	R/W	R/W

### ISCR L

Bit	:	7	6	5	4	3	2	1	0
		IRQ3SCB	IRQ3SCA	IRQ2SCB	IRQ2SCA	IRQ1SCB	IRQ1SCA	IRQ0SCB	IRQ0SCA
Initial value :		0	0	0	0	0	0	0	0
R/W	:	R/W	R/W	R/W	R/W	R/W	R/W	R/W	R/W

The ISCR registers are 16-bit readable/writable registers that select rising edge, falling edge, or both edge detection, or level sensing, for the input at pins  $\overline{\text{IRQ7}}$  to  $\overline{\text{IRQ0}}$ .

The ISCR registers are initialized to H'0000 by a reset and in hardware standby mode.

They are not initialized in software standby mode.

**Bits 15 to 0:** IRQ7 Sense Control A and B (IRQ7SCA, IRQ7SCB) to IRQ0 Sense Control A and B (IRQ0SCA, IRQ0SCB)

#### Bits 15 to 0

IRQ7SCB to IRQ0SCB	IRQ7SCA to IRQ0SCA	Description
0	0	Interrupt request generated at $\overline{\text{IRQ7}}$ to $\overline{\text{IRQ0}}$ input low level (initial value)
	1	Interrupt request generated at falling edge of $\overline{\text{IRQ7}}$ to $\overline{\text{IRQ0}}$ input
1	0	Interrupt request generated at rising edge of $\overline{\text{IRQ7}}$ to $\overline{\text{IRQ0}}$ input
	1	Interrupt request generated at both falling and rising edges of $\overline{\text{IRQ7}}$ to $\overline{\text{IRQ0}}$ input

### 5.2.5 IRQ Status Register (ISR)

Bit	:	7	6	5	4	3	2	1	0
		IRQ7F	IRQ6F	IRQ5F	IRQ4F	IRQ3F	IRQ2F	IRQ1F	IRQ0F
Initial value	:	0	0	0	0	0	0	0	0
R/W	:	R/(W)*	R/(W)*	R/(W)*	R/(W)*	R/(W)*	R/(W)*	R/(W)*	R/(W)*

Note: \* Only 0 can be written, to clear the flag.

ISR is an 8-bit readable/writable register that indicates the status of IRQ7 to IRQ0 interrupt requests.

ISR is initialized to H'00 by a reset and in hardware standby mode.

They are not initialized in software standby mode.

**Bits 7 to 0—IRQ7 to IRQ0 flags (IRQ7F to IRQ0F):** These bits indicate the status of IRQ7 to IRQ0 interrupt requests.

#### Bit n

IRQnF	Description
0	<p>[Clearing conditions] (Initial value)</p> <ul style="list-style-type: none"> <li>• Cleared by reading IRQnF flag when IRQnF = 1, then writing 0 to IRQnF flag</li> <li>• When interrupt exception handling is executed when low-level detection is set (IRQnSCB = IRQnSCA = 0) and <math>\overline{\text{IRQn}}</math> input is high</li> <li>• When IRQn interrupt exception handling is executed when falling, rising, or both-edge detection is set (IRQnSCB = 1 or IRQnSCA = 1)</li> <li>• When the DTC* is activated by an IRQn interrupt, and the DISEL bit in MRB of the DTC* is cleared to 0</li> </ul>
1	<p>[Setting conditions]</p> <ul style="list-style-type: none"> <li>• When <math>\overline{\text{IRQn}}</math> input goes low when low-level detection is set (IRQnSCB = IRQnSCA = 0)</li> <li>• When a falling edge occurs in <math>\overline{\text{IRQn}}</math> input when falling edge detection is set (IRQnSCB = 0, IRQnSCA = 1)</li> <li>• When a rising edge occurs in <math>\overline{\text{IRQn}}</math> input when rising edge detection is set (IRQnSCB = 1, IRQnSCA = 0)</li> <li>• When a falling or rising edge occurs in <math>\overline{\text{IRQn}}</math> input when both-edge detection is set (IRQnSCB = IRQnSCA = 1)</li> </ul>

(n = 7 to 0)

Note: \* The DTC function is not available in the H8S/2695.

## 5.3 Interrupt Sources

Interrupt sources comprise external interrupts (NMI and IRQ7 to IRQ0) and internal interrupts (72 sources).

### 5.3.1 External Interrupts

There are nine external interrupts: NMI and IRQ7 to IRQ0. Of these, NMI and IRQ7 to IRQ0 can be used to restore the H8S/2633 Series from software standby mode.

**NMI Interrupt:** NMI is the highest-priority interrupt, and is always accepted by the CPU regardless of the interrupt control mode or the status of the CPU interrupt mask bits. The NMIEG bit in SYSCR can be used to select whether an interrupt is requested at a rising edge or a falling edge on the NMI pin.

The vector number for NMI interrupt exception handling is 7.

**IRQ7 to IRQ0 Interrupts:** Interrupts IRQ7 to IRQ0 are requested by an input signal at pins  $\overline{\text{IRQ}}7$  to  $\overline{\text{IRQ}}0$ . Interrupts IRQ7 to IRQ0 have the following features:

- Using ISCR, it is possible to select whether an interrupt is generated by a low level, falling edge, rising edge, or both edges, at pins  $\overline{\text{IRQ}}7$  to  $\overline{\text{IRQ}}0$ .
- Enabling or disabling of interrupt requests IRQ7 to IRQ0 can be selected with IER.
- The interrupt priority level can be set with IPR.
- The status of interrupt requests IRQ7 to IRQ0 is indicated in ISR. ISR flags can be cleared to 0 by software.

A block diagram of interrupts IRQ7 to IRQ0 is shown in figure 5-2.

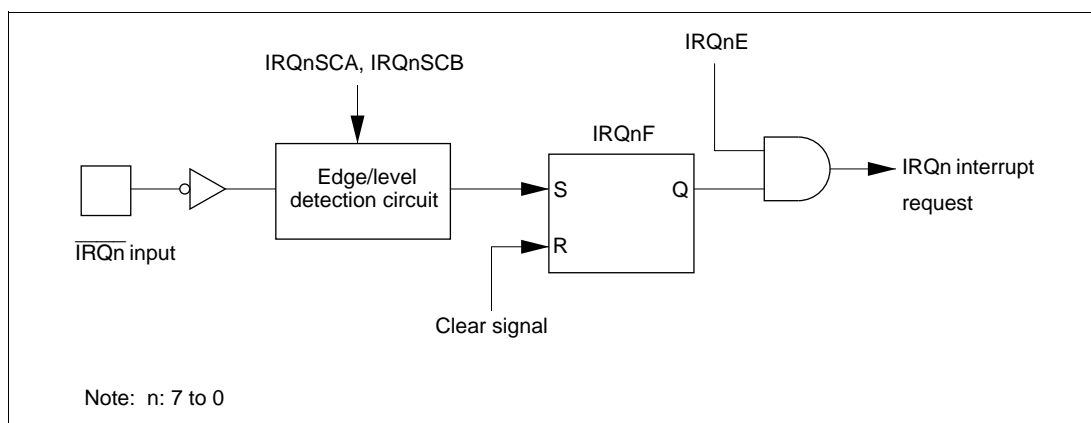
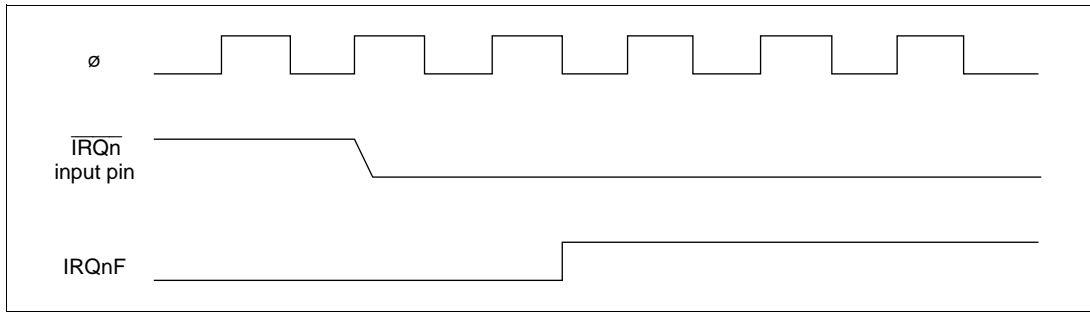


Figure 5-2 Block Diagram of Interrupts IRQ7 to IRQ0

Figure 5-3 shows the timing of setting IRQnF.



**Figure 5-3 Timing of Setting IRQnF**

The vector numbers for IRQ7 to IRQ0 interrupt exception handling are 23 to 16.

Detection of IRQ7 to IRQ0 interrupts does not depend on whether the relevant pin has been set for input or output. However, when a pin is used as an external interrupt input pin, do not clear the corresponding DDR to 0 and use the pin as an I/O pin for another function.

### 5.3.2 Internal Interrupts

There are 72\*<sup>1</sup> sources for internal interrupts from on-chip supporting modules.

- For each on-chip supporting module there are flags that indicate the interrupt request status, and enable bits that select enabling or disabling of these interrupts. If both of these are set to 1 for a particular interrupt source, an interrupt request is issued to the interrupt controller.
- The interrupt priority level can be set by means of IPR.
- The DMAC\*<sup>2</sup> and DTC\*<sup>2</sup> can be activated by a TPU, 8-bit timer\*<sup>2</sup>, SCI, or other interrupt request. When the DMAC\*<sup>2</sup> and DTC\*<sup>2</sup> are activated by an interrupt, the interrupt control mode and interrupt mask bits are not affected.

Notes: \*1 The H8S/2695 has 54 sources for internal interrupts from on-chip supporting modules.

\*2 This function is not available in the H8S/2695.

### 5.3.3 Interrupt Exception Handling Vector Table

Tables 5-4(a) and 5-4(b) show interrupt exception handling sources, vector addresses, and interrupt priorities. For default priorities, the lower the vector number, the higher the priority.

Priorities among modules can be set by means of the IPR. The situation when two or more modules are set to the same priority, and priorities within a module, are fixed as shown in table 5-4.



**Table 5-4(a) Interrupt Sources, Vector Addresses, and Interrupt Priorities  
(H8S/2633, H8S/2632, H8S/2631, H8S/2633R)**

Interrupt Source	Origin of Interrupt Source	Vector Number	Vector Address*		Priority
			Advanced Mode	IPR	
NMI	External pin	7	H'001C		High ↑
IRQ0		16	H'0040	IPRA6 to 4	
IRQ1		17	H'0044	IPRA2 to 0	
IRQ2		18	H'0048	IPRB6 to 4	
IRQ3		19	H'004C		
IRQ4		20	H'0050	IPRB2 to 0	
IRQ5		21	H'0054		
IRQ6		22	H'0058	IPRC6 to 4	
IRQ7		23	H'005C		
SWDTEND (software activation interrupt end)		DTC	24	H'0060	
WOVI0 (interval timer)	Watchdog timer 0	25	H'0064	IPRD6 to 4	
Reserved	—	26	H'0068	IPRD2 to 0	
PC break	PC break	27	H'006C	IPRE6 to 4	
ADI (A/D conversion end)	A/D	28	H'0070	IPRE2 to 0	
WOVI1 (interval timer)	Watchdog timer 1	29	H'0074		
Reserved	—	30	H'0078		
		31	H'007C		
TGIOA (TGR0A input capture/compare match)	TPU channel 0	32	H'0080	IPRF6 to 4	
TGIOB (TGR0B input capture/compare match)		33	H'0084		
TGIOC (TGR0C input capture/compare match)		34	H'0088		
TGIOD (TGR0D input capture/compare match)		35	H'008C		
TCIOV (overflow 0)		36	H'0090		
Reserved		—	37	H'0094	
	38		H'0098		
	39		H'009C		

Interrupt Source	Origin of Interrupt Source	Vector Number	Vector Address*		Priority
			Advanced Mode	IPR	
TGI1A (TGR1A input capture/compare match)	TPU channel 1	40	H'00A0	IPRF2 to 0	High ↑
TGI1B (TGR1B input capture/compare match)		41	H'00A4		
TCI1V (overflow 1)		42	H'00A8		
TCI1U (underflow 1)		43	H'00AC		
TGI2A (TGR2A input capture/compare match)	TPU channel 2	44	H'00B0	IPRG6 to 4	
TGI2B (TGR2B input capture/compare match)		45	H'00B4		
TCI2V (overflow 2)		46	H'00B8		
TCI2U (underflow 2)		47	H'00BC		
TGI3A (TGR3A input capture/compare match)	TPU channel 3	48	H'00C0	IPRG2 to 0	
TGI3B (TGR3B input capture/compare match)		49	H'00C4		
TGI3C (TGR3C input capture/compare match)		50	H'00C8		
TGI3D (TGR3D input capture/compare match)		51	H'00CC		
TCI3V (overflow 3)		52	H'00D0		
Reserved		—	53		H'00D4
		54	H'00D8		
		55	H'00DC		
TGI4A (TGR4A input capture/compare match)	TPU channel 4	56	H'00E0	IPRH6 to 4	
TGI4B (TGR4B input capture/compare match)		57	H'00E4		
TCI4V (overflow 4)		58	H'00E8		
TCI4U (underflow 4)		59	H'00EC		
TGI5A (TGR5A input capture/compare match)	TPU channel 5	60	H'00F0	IPRH2 to 0	↓ Low
TGI5B (TGR5B input capture/compare match)		61	H'00F4		
TCI5V (overflow 5)		62	H'00F8		
TCI5U (underflow 5)		63	H'00FC		



Interrupt Source	Origin of Interrupt Source	Vector Number	Vector Address*	IPR	Priority
			Advanced Mode		
CMIA0 (compare match A2)	8 bit timer channel 2	92	H'0170	IPRL6 to 4	High ↑
CMIB0 (compare match B2)		93	H'0174		
OVI0 (overflow 2)		94	H'0178		
Reserved	—	95	H'017C		
CMIA1 (compare match A3)	8 bit timer channel 3	96	H'0180		
CMIB1 (compare match B3)		97	H'0184		
OVI1 (overflow 3)		98	H'0188		
Reserved	—	99	H'018C		
IICI0 (1 byte transmission/reception completed)	IIC channel 0 (optional)	100	H'0190		
DDCSW1 (format switch)		101	H'0194		
IICI1 (1 byte transmission/reception completed)	IIC channel 1 (optional)	102	H'0198		
Reserved		103	H'019C		
Reserved	—	104	H'01A0	IPRM6 to 4	
		105	H'01A4		
		106	H'01A8		
		107	H'01AC		
Reserved	—	108	H'01B0	IPRM2 to 0	
		109	H'01B4		
		110	H'01B8		
		111	H'01BC		
Reserved	—	112	H'01C0	IPRN6 to 4	
		113	H'01C4		
		114	H'01C8		
		115	H'01CC		
Reserved	—	116	H'01D0	IPRN2 to 0	
		117	H'01D4		
		118	H'01D8		
		119	H'01DC		
ERI3 (reception error 3)	SCI channel 3	120	H'01E0	IPRO6 to 4	
RXI3 (reception completed 3)		121	H'01E4		
TXI3 (transmission data empty 3)		122	H'01E8		
TEI3 (transmission end 3)		123	H'01EC		
ERI4 (reception error 4)	SCI channel 4	124	H'01F0	IPRO2 to 0	
RXI4 (reception completed 4)		125	H'01F4		
TXI4 (transmission data empty 4)		126	H'01F8		
TEI4 (transmission end 4)		127	H'01FC		
					Low ↓

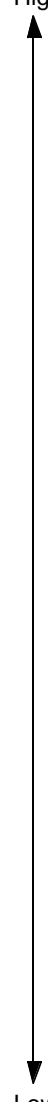
Note: \* Lower 16 bits of the start address.

**Table 5-4(b) Interrupt Sources, Vector Addresses, and Interrupt Priorities (H8S/2695)**

Interrupt Source	Origin of Interrupt Source	Vector Number	Vector Address*		Priority
			Advanced Mode	IPR	
NMI	External pin	7	H'001C		High ↑
IRQ0		16	H'0040	IPRA6 to 4	
IRQ1		17	H'0044	IPRA2 to 0	
IRQ2		18	H'0048	IPRB6 to 4	
IRQ3		19	H'004C		
IRQ4		20	H'0050	IPRB2 to 0	
IRQ5		21	H'0054		
IRQ6		22	H'0058	IPRC6 to 4	
IRQ7		23	H'005C		
Reserved		—	24	H'0060	
WOVI0 (interval timer)	Watchdog timer 0	25	H'0064	IPRD6 to 4	
Reserved		—	26	H'0068	IPRD2 to 0
		27	H'006C	IPRE6 to 4	
ADI (A/D conversion end)	A/D	28	H'0070	IPRE2 to 0	
Reserved		—	29	H'0074	
			30	H'0078	
			31	H'007C	
TGI0A (TGR0A input capture/compare match)	TPU channel 0	32	H'0080	IPRF6 to 4	
TGI0B (TGR0B input capture/compare match)		33	H'0084		
TGI0C (TGR0C input capture/compare match)		34	H'0088		
TGI0D (TGR0D input capture/compare match)		35	H'008C		
TCIOV (overflow 0)		36	H'0090		
Reserved		—	37	H'0094	
		38	H'0098		
		39	H'009C		
				Low ↓	

Interrupt Source	Origin of Interrupt Source	Vector Number	Vector Address*		Priority
			Advanced Mode	IPR	
TGI1A (TGR1A input capture/compare match)	TPU channel 1	40	H'00A0	IPRF2 to 0	
TGI1B (TGR1B input capture/compare match)		41	H'00A4		
TCI1V (overflow 1)		42	H'00A8		
TCI1U (underflow 1)		43	H'00AC		
TGI2A (TGR2A input capture/compare match)	TPU channel 2	44	H'00B0	IPRG6 to 4	
TGI2B (TGR2B input capture/compare match)		45	H'00B4		
TCI2V (overflow 2)		46	H'00B8		
TCI2U (underflow 2)		47	H'00BC		
TGI3A (TGR3A input capture/compare match)	TPU channel 3	48	H'00C0	IPRG2 to 0	
TGI3B (TGR3B input capture/compare match)		49	H'00C4		
TGI3C (TGR3C input capture/compare match)		50	H'00C8		
TGI3D (TGR3D input capture/compare match)		51	H'00CC		
TCI3V (overflow 3)		52	H'00D0		
Reserved		—	53		H'00D4
		54	H'00D8		
		55	H'00DC		
TGI4A (TGR4A input capture/compare match)	TPU channel 4	56	H'00E0	IPRH6 to 4	
TGI4B (TGR4B input capture/compare match)		57	H'00E4		
TCI4V (overflow 4)		58	H'00E8		
TCI4U (underflow 4)		59	H'00EC		
TGI5A (TGR5A input capture/compare match)	TPU channel 5	60	H'00F0	IPRH2 to 0	
TGI5B (TGR5B input capture/compare match)		61	H'00F4		
TCI5V (overflow 5)		62	H'00F8		
TCI5U (underflow 5)		63	H'00FC		

Interrupt Source	Origin of Interrupt Source	Vector Number	Vector Address*	IPR	Priority
			Advanced Mode		
Reserved	—	64	H'0100	IPRI6 to 4	High
		65	H'0104		
		66	H'0108		
		67	H'010C		
Reserved	—	68	H'0110	IPRI2 to 0	
		69	H'0114		
		70	H'0118		
		71	H'011C		
Reserved	—	72	H'0120	IPRJ6 to 4	
		73	H'0124		
		74	H'0128		
		75	H'012C		
		76	H'0130		
		77	H'0134		
		78	H'0138		
		79	H'013C		
ERI0 (receive error 0)	SCI channel 0	80	H'0140	IPRJ2 to 0	
RX10 (reception completed 0)		81	H'0144		
TX10 (transmit data empty 0)		82	H'0148		
TEI0 (transmission end 0)		83	H'014C		
ERI1 (receive error 1)	SCI channel 1	84	H'0150	IPRK6 to 4	
RX11 (reception completed 1)		85	H'0154		
TX11 (transmit data empty 1)		86	H'0158		
TEI1 (transmission end 1)		87	H'015C		
ERI2 (receive error 2)	SCI channel 2	88	H'0160	IPRK2 to 0	
RX12 (reception completed 2)		89	H'0164		
TX12 (transmit data empty 2)		90	H'0168		
TEI2 (transmission end 2)		91	H'016C		
Reserved	—	92	H'0170	IPRL6 to 4	
		93	H'0174		
		94	H'0178		
		95	H'017C		
		96	H'0180		
		97	H'0184		
		98	H'0188		
		99	H'018C		



Interrupt Source	Origin of Interrupt Source	Vector Number	Vector Address*		Priority
			Advanced Mode	IPR	
Reserved	—	100	H'0190	IPRL2 to 0	High
		101	H'0194		
		102	H'0198		
		103	H'019C		
Reserved	—	104	H'01A0	IPRM6 to 4	
		105	H'01A4		
		106	H'01A8		
		107	H'01AC		
Reserved	—	108	H'01B0	IPRM2 to 0	
		109	H'01B4		
		110	H'01B8		
		111	H'01BC		
Reserved	—	112	H'01C0	IPRN6 to 4	
		113	H'01C4		
		114	H'01C8		
		115	H'01CC		
Reserved	—	116	H'01D0	IPRN2 to 0	
		117	H'01D4		
		118	H'01D8		
		119	H'01DC		
ERI3 (reception error 3)	SCI channel 3	120	H'01E0	IPRO6 to 4	
RX13 (reception completed 3)		121	H'01E4		
TX13 (transmission data empty 3)		122	H'01E8		
TE13 (transmission end 3)		123	H'01EC		
ERI4 (reception error 4)	SCI channel 4	124	H'01F0	IPRO2 to 0	
RX14 (reception completed 4)		125	H'01F4		
TX14 (transmission data empty 4)		126	H'01F8		
TE14 (transmission end 4)		127	H'01FC		

Note: \* Lower 16 bits of the start address.



## 5.4 Interrupt Operation

### 5.4.1 Interrupt Control Modes and Interrupt Operation

Interrupt operations in the H8S/2633 Series differ depending on the interrupt control mode.

NMI interrupts are accepted at all times except in the reset state and the hardware standby state. In the case of IRQ interrupts and on-chip supporting module interrupts, an enable bit is provided for each interrupt. Clearing an enable bit to 0 disables the corresponding interrupt request. Interrupt sources for which the enable bits are set to 1 are controlled by the interrupt controller.

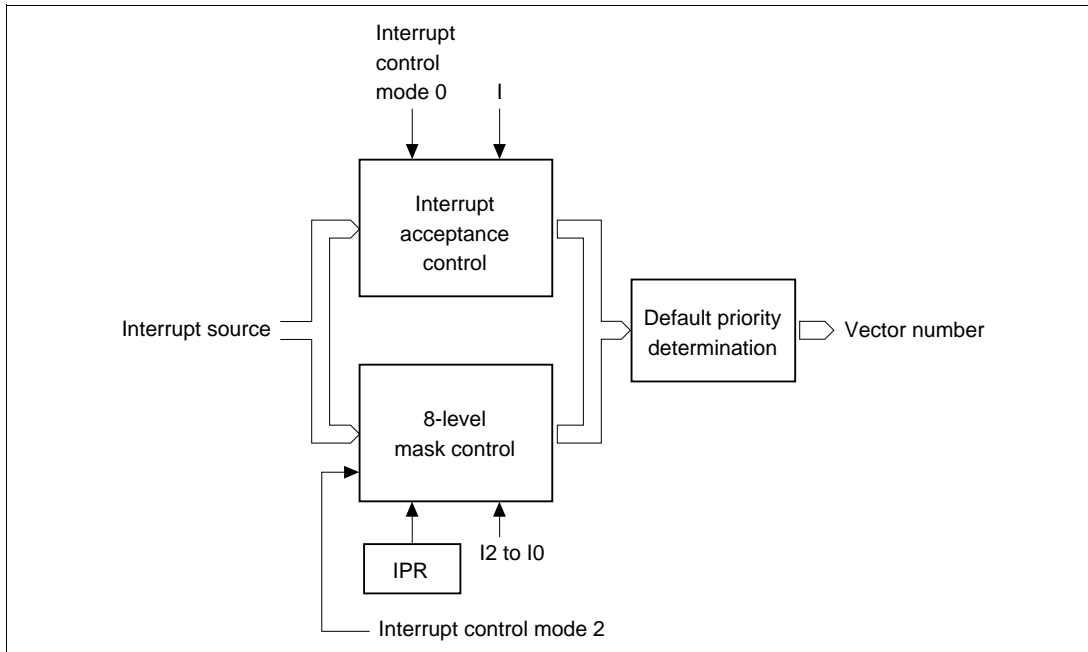
Table 5-5 shows the interrupt control modes.

The interrupt controller performs interrupt control according to the interrupt control mode set by the INTM1 and INTM0 bits in SYSCR, the priorities set in IPR, and the masking state indicated by the I and UI bits in the CPU's CCR, and bits I2 to I0 in EXR.

**Table 5-5 Interrupt Control Modes**

Interrupt Control Mode	SYSCR		Priority Setting Registers	Interrupt Mask Bits	Description
	INTM1	INTM0			
0	0	0	—	I	Interrupt mask control is performed by the I bit.
—	—	1	—	—	Setting prohibited
2	1	0	IPR	I2 to I0	8-level interrupt mask control is performed by bits I2 to I0. 8 priority levels can be set with IPR.
—	—	1	—	—	Setting prohibited

Figure 5-4 shows a block diagram of the priority decision circuit.



**Figure 5-4 Block Diagram of Interrupt Control Operation**

**(1) Interrupt Acceptance Control**

In interrupt control mode 0, interrupt acceptance is controlled by the I bit in CCR.

Table 5-6 shows the interrupts selected in each interrupt control mode.

**Table 5-6 Interrupts Selected in Each Interrupt Control Mode (1)**

Interrupt Control Mode	Interrupt Mask Bits	
	I	Selected Interrupts
0	0	All interrupts
	1	NMI interrupts
2	*	All interrupts

**Legend**

\* : Don't care

## (2) 8-Level Control

In interrupt control mode 2, 8-level mask level determination is performed for the selected interrupts in interrupt acceptance control according to the interrupt priority level (IPR).

The interrupt source selected is the interrupt with the highest priority level, and whose priority level set in IPR is higher than the mask level.

**Table 5-7 Interrupts Selected in Each Interrupt Control Mode (2)**

Interrupt Control Mode	Selected Interrupts
0	All interrupts
2	Highest-priority-level (IPR) interrupt whose priority level is greater than the mask level (IPR > I2 to I0)

## (3) Default Priority Determination

When an interrupt is selected by 8-level control, its priority is determined and a vector number is generated.

If the same value is set for IPR, acceptance of multiple interrupts is enabled, and so only the interrupt source with the highest priority according to the preset default priorities is selected and has a vector number generated.

Interrupt sources with a lower priority than the accepted interrupt source are held pending.

Table 5-8 shows operations and control signal functions in each interrupt control mode.

**Table 5-8 Operations and Control Signal Functions in Each Interrupt Control Mode**

Interrupt Control Mode	Setting		Interrupt Acceptance Control		8-Level Control		Default Priority Determination	T (Trace)	
	INTM1	INTM0	I	IM	I2 to I0	IPR			
0	0	0	○	IM	X	—	—*2	○	—
2	1	0	X	—*1	○	IM	PR	○	T

### Legend

- : Interrupt operation control performed
- X : No operation (All interrupts enabled)
- IM : Used as interrupt mask bit
- PR : Sets priority
- : Not used

Notes: \*1 Set to 1 when interrupt is accepted.

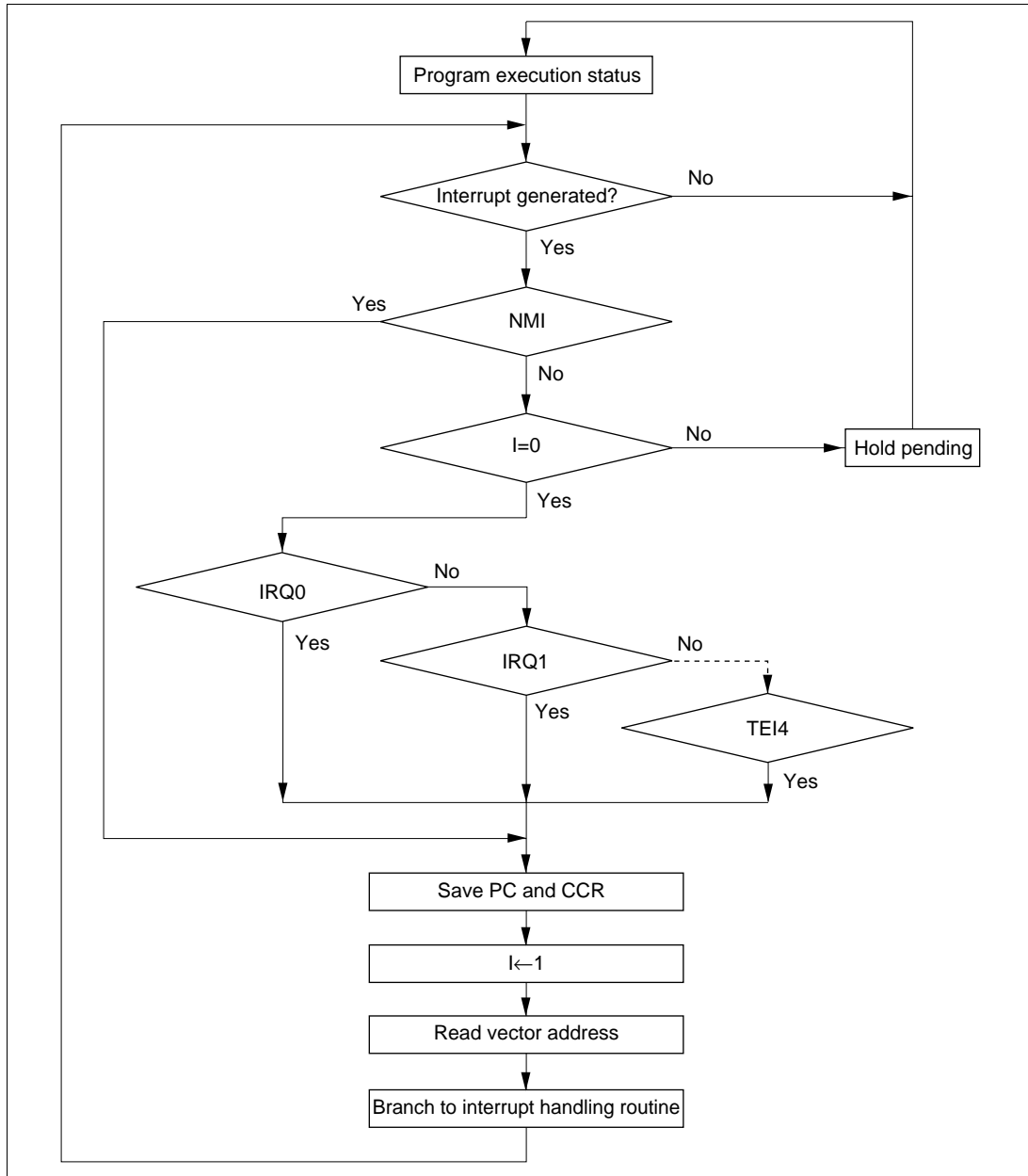
\*2 Keep the initial setting.

### 5.4.2 Interrupt Control Mode 0

Enabling and disabling of IRQ interrupts and on-chip supporting module interrupts can be set by means of the I bit in the CPU's CCR. Interrupts are enabled when the I bit is cleared to 0, and disabled when set to 1.

Figure 5-5 shows a flowchart of the interrupt acceptance operation in this case.

- [1] If an interrupt source occurs when the corresponding interrupt enable bit is set to 1, an interrupt request is sent to the interrupt controller.
- [2] The I bit is then referenced. If the I bit is cleared to 0, the interrupt request is accepted. If the I bit is set to 1, only an NMI interrupt is accepted, and other interrupt requests are held pending.
- [3] Interrupt requests are sent to the interrupt controller, the highest-ranked interrupt according to the priority system is accepted, and other interrupt requests are held pending.
- [4] When an interrupt request is accepted, interrupt exception handling starts after execution of the current instruction has been completed.
- [5] The PC and CCR are saved to the stack area by interrupt exception handling. The PC saved on the stack shows the address of the first instruction to be executed after returning from the interrupt handling routine.
- [6] Next, the I bit in CCR is set to 1. This masks all interrupts except NMI.
- [7] A vector address is generated for the accepted interrupt, and execution of the interrupt handling routine starts at the address indicated by the contents of that vector address.



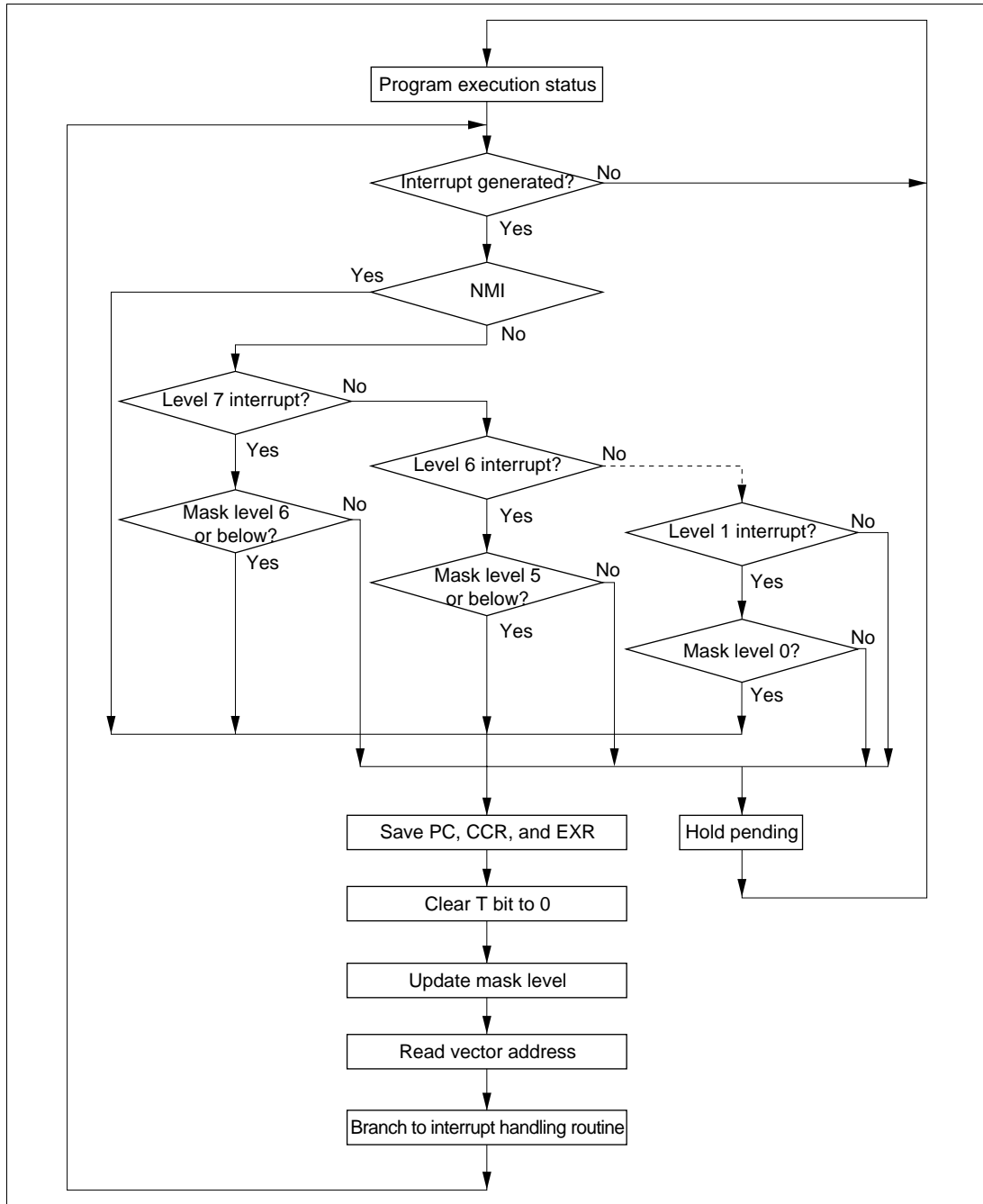
**Figure 5-5** Flowchart of Procedure Up to Interrupt Acceptance in Interrupt Control Mode 0

### 5.4.3 Interrupt Control Mode 2

Eight-level masking is implemented for IRQ interrupts and on-chip supporting module interrupts by comparing the interrupt mask level set by bits I2 to I0 of EXR in the CPU with IPR.

Figure 5-6 shows a flowchart of the interrupt acceptance operation in this case.

- [1] If an interrupt source occurs when the corresponding interrupt enable bit is set to 1, an interrupt request is sent to the interrupt controller.
- [2] When interrupt requests are sent to the interrupt controller, the interrupt with the highest priority according to the interrupt priority levels set in IPR is selected, and lower-priority interrupt requests are held pending. If a number of interrupt requests with the same priority are generated at the same time, the interrupt request with the highest priority according to the priority system shown in table 5-4 is selected.
- [3] Next, the priority of the selected interrupt request is compared with the interrupt mask level set in EXR. An interrupt request with a priority no higher than the mask level set at that time is held pending, and only an interrupt request with a priority higher than the interrupt mask level is accepted.
- [4] When an interrupt request is accepted, interrupt exception handling starts after execution of the current instruction has been completed.
- [5] The PC, CCR, and EXR are saved to the stack area by interrupt exception handling. The PC saved on the stack shows the address of the first instruction to be executed after returning from the interrupt handling routine.
- [6] The T bit in EXR is cleared to 0. The interrupt mask level is rewritten with the priority level of the accepted interrupt.  
If the accepted interrupt is NMI, the interrupt mask level is set to H'7.
- [7] A vector address is generated for the accepted interrupt, and execution of the interrupt handling routine starts at the address indicated by the contents of that vector address.



**Figure 5-6 Flowchart of Procedure Up to Interrupt Acceptance in Interrupt Control Mode 2**

### 5.4.4 Interrupt Exception Handling Sequence

Figure 5-7 shows the interrupt exception handling sequence. The example shown is for the case where interrupt control mode 0 is set in advanced mode, and the program area and stack area are in on-chip memory.

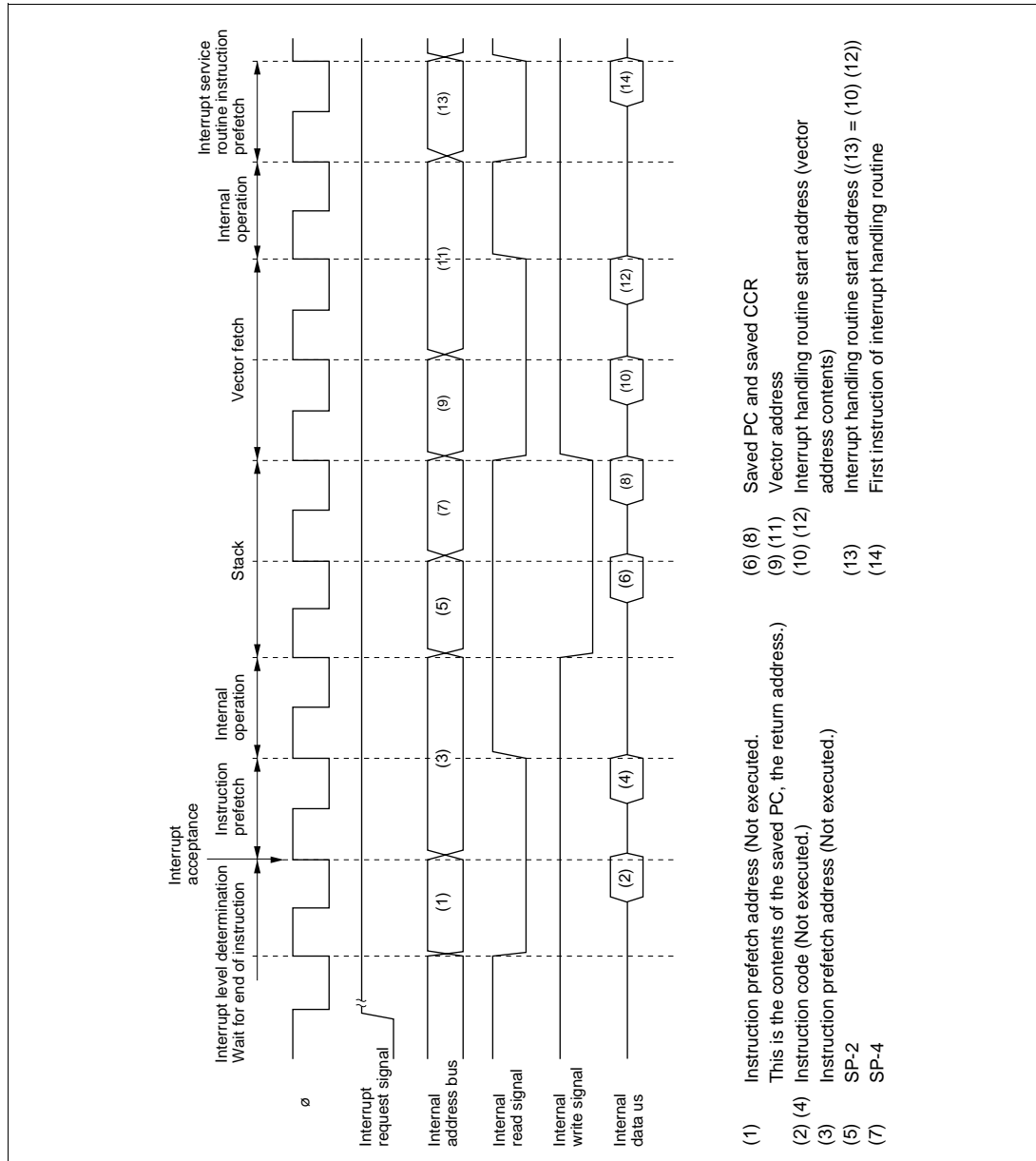


Figure 5-7 Interrupt Exception Handling



### 5.4.5 Interrupt Response Times

The H8S/2633 Series is capable of fast word transfer instruction to on-chip memory, and the program area is provided in on-chip ROM and the stack area in on-chip RAM, enabling high-speed processing.

Table 5-9 shows interrupt response times - the interval between generation of an interrupt request and execution of the first instruction in the interrupt handling routine. The execution status symbols used in table 5-9 are explained in table 5-10.

**Table 5-9 Interrupt Response Times**

No.	Execution Status	Normal Mode* <sup>5</sup>		Advanced Mode	
		INTM1 = 0	INTM1 = 1	INTM1 = 0	INTM1 = 1
1	Interrupt priority determination* <sup>1</sup>	3	3	3	3
2	Number of wait states until executing instruction ends* <sup>2</sup>	1 to (19+2·S <sub>I</sub> )	1 to (19+2·S <sub>I</sub> )	1 to (19+2·S <sub>I</sub> )	1 to (19+2·S <sub>I</sub> )
3	PC, CCR, EXR stack save	2·S <sub>K</sub>	3·S <sub>K</sub>	2·S <sub>K</sub>	3·S <sub>K</sub>
4	Vector fetch	S <sub>I</sub>	S <sub>I</sub>	2·S <sub>I</sub>	2·S <sub>I</sub>
5	Instruction fetch* <sup>3</sup>	2·S <sub>I</sub>	2·S <sub>I</sub>	2·S <sub>I</sub>	2·S <sub>I</sub>
6	Internal processing* <sup>4</sup>	2	2	2	2
Total (using on-chip memory)		11 to 31	12 to 32	12 to 32	13 to 33

Notes: \*1 Two states in case of internal interrupt.

\*2 Refers to MULXS and DIVXS instructions.

\*3 Prefetch after interrupt acceptance and interrupt handling routine prefetch.

\*4 Internal processing after interrupt acceptance and internal processing after vector fetch.

\*5 Not available in the H8S/2633 Series.

**Table 5-10 Number of States in Interrupt Handling Routine Execution Statuses**

Symbol		Internal Memory	Object of Access			
			External Device			
			8 Bit Bus		16 Bit Bus	
		2-State Access	3-State Access	2-State Access	3-State Access	
Instruction fetch	$S_i$	1	4	$6+2m$	2	$3+m$
Branch address read	$S_j$					
Stack manipulation	$S_k$					

**Legend**

m : Number of wait states in an external device access.

## 5.5 Usage Notes

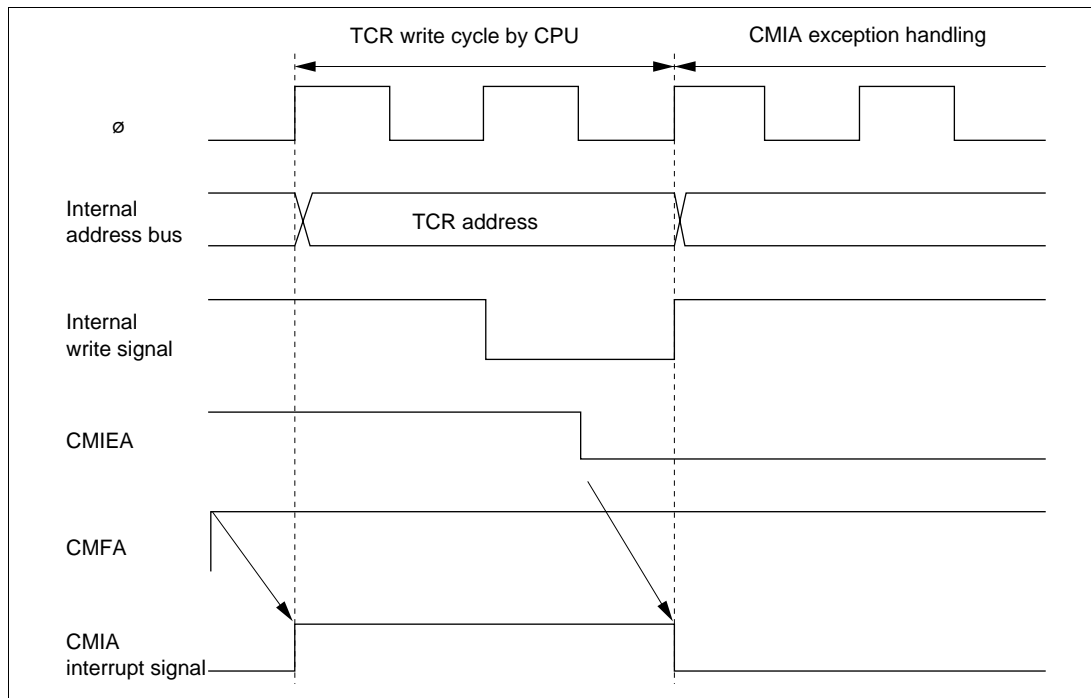
### 5.5.1 Contention between Interrupt Generation and Disabling

When an interrupt enable bit is cleared to 0 to disable interrupts, the disabling becomes effective after execution of the instruction.

In other words, when an interrupt enable bit is cleared to 0 by an instruction such as BCLR or MOV, if an interrupt is generated during execution of the instruction, the interrupt concerned will still be enabled on completion of the instruction, and so interrupt exception handling for that interrupt will be executed on completion of the instruction. However, if there is an interrupt request of higher priority than that interrupt, interrupt exception handling will be executed for the higher-priority interrupt, and the lower-priority interrupt will be ignored.

The same also applies when an interrupt source flag is cleared to 0.

Figure 5-8 shows an example in which the CMIEA bit in the TMR's TCR register is cleared to 0.



**Figure 5-8 Contention between Interrupt Generation and Disabling**

The above contention will not occur if an enable bit or interrupt source flag is cleared to 0 while the interrupt is masked.

### 5.5.2 Instructions that Disable Interrupts

Instructions that disable interrupts are LDC, ANDC, ORC, and XORC. After any of these instructions is executed, all interrupts including NMI are disabled and the next instruction is always executed. When the I bit is set by one of these instructions, the new value becomes valid two states after execution of the instruction ends.

### 5.5.3 Times when Interrupts are Disabled

There are times when interrupt acceptance is disabled by the interrupt controller.

The interrupt controller disables interrupt acceptance for a 3-state period after the CPU has updated the mask level with an LDC, ANDC, ORC, or XORC instruction.

#### 5.5.4 Interrupts during Execution of EEPMOV Instruction

Interrupt operation differs between the EEPMOV.B instruction and the EEPMOV.W instruction.

With the EEPMOV.B instruction, an interrupt request (including NMI) issued during the transfer is not accepted until the move is completed.

With the EEPMOV.W instruction, if an interrupt request is issued during the transfer, interrupt exception handling starts at a break in the transfer cycle. The PC value saved on the stack in this case is the address of the next instruction.

Therefore, if an interrupt is generated during execution of an EEPMOV.W instruction, the following coding should be used.

```
L1:   EEPMOV.W
      MOV.W   R4,R4
      BNE    L1
```

### 5.6 DTC and DMAC Activation by Interrupt (DMAC and DTC functions are not available in the H8S/2695)

#### 5.6.1 Overview

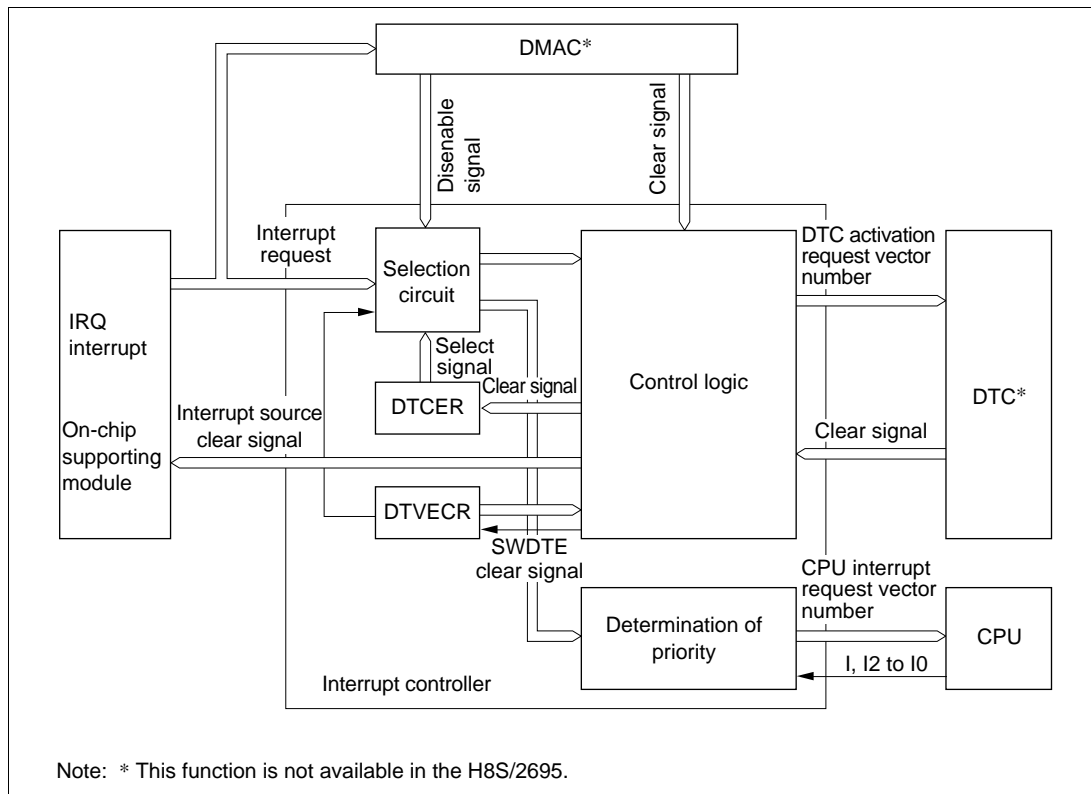
The DTC and DMAC can be activated by an interrupt. In this case, the following options are available:

- Interrupt request to CPU
- Activation request to DTC
- Activation request to DMAC
- Selection of a number of the above

For details of interrupt requests that can be used with to activate the DTC and DMAC, see section 9, Data Transfer Controller (DTC) and section 8, DMA Controller (DMAC).

#### 5.6.2 Block Diagram

Figure 5-9 shows a block diagram of the DTC and DMAC interrupt controller.



**Figure 5-9 Interrupt Control for DTC\* and DMAC\***

### 5.6.3 Operation (DMAC and DTC functions are not available in the H8S/2695)

The interrupt controller has three main functions in DTC and DMAC control.

**(1) Selection of Interrupt Source:** DMAC inputs activation factor directly to each channel. The activation factors for each channel of DMAC are selected by DTF3 to DTF0 bits of DMACR. The DTA bit of DMABCR can be used to select whether the selected activation factors are managed by DMAC. By setting the DTA bit to 1, the interrupt factor which were the activation factor for that DMAC do not act as the DTC activation factor or the CPU interrupt factor.

Interrupt factors other than the interrupts managed by the DMAC are selected as DTC activation request or CPU interrupt request by the DTCERA to DTCERF of DTC and the DTCE bit of DTCERI.

By specifying the DISEL bit of the DTC's MRB, it is possible to clear the DTCE bit to 0 after DTC data transfer, and request a CPU interrupt.

If DTC carries out the designate number of data transfers and the transfer counter reads 0, after DTC data transfer, the DTCE bit is also cleared to 0, and a CPU interrupt requested.

**(2) Determination of Priority:** The DTC activation source is selected in accordance with the default priority order, and is not affected by mask or priority levels. See section 8.6, Interrupts, and section 9.3.3, DTC Vector Table for the respective priority.

**(3) Operation Order:** If the same interrupt is selected as a DTC activation source and a CPU interrupt source, the DTC data transfer is performed first, followed by CPU interrupt exception handling.

If the same interrupt is selected as the DMAC activation factor and as the DTC activation factor or CPU interrupt factor, these operate independently. They operate in accordance with the respective operating states and bus priorities.

Table 5-11 shows the interrupt factor clear control and selection of interrupt factors by specification of the DTA bit of DMAC's DMABCR, DTC's DTCERA to DTCERF, DTCERI's DTCE bits, and the DISEL bit of DTC's MRB.

**Table 5-11 Interrupt Source Selection and Clearing Control**

Settings					
DMAC* <sup>1</sup>	DTC* <sup>1</sup>		Interrupt Source Selection/Clearing Control		
DTA* <sup>1</sup>	DTCE* <sup>1</sup>	DISEL* <sup>1</sup>	DMAC* <sup>1</sup>	DTC* <sup>1</sup>	CPU
0	0	*	○	X	△
		1	○	△	X
			1	○	○
1	*	*	△	X	X

**Legend**

- △ : The relevant interrupt is used. Interrupt source clearing is performed.  
(The CPU should clear the source flag in the interrupt handling routine.)
- : The relevant interrupt is used. The interrupt source is not cleared.
- X : The relevant bit cannot be used.
- \* : Don't care

Note: \*<sup>1</sup> This function is not available in the H8S/2695.

**(4) Notes on Use:** SCI and A/D converter interrupt sources are cleared when the DMAC\* or DTC\* reads or writes to the prescribed register, and are not dependent upon the DTA\*, DTCE\*, and DISEL\* bits.

Note: \* This function is not available in the H8S/2695.

## Section 6 PC Break Controller (PBC)

(This function is not available in the H8S/2695)

### 6.1 Overview

The PC break controller (PBC) provides functions that simplify program debugging. Using these functions, it is easy to create a self-monitoring debugger, enabling programs to be debugged with the chip alone, without using an in-circuit emulator. Four break conditions can be set in the PBC: instruction fetch, data read, data write, and data read/write.

#### 6.1.1 Features

The PC break controller has the following features:

- Two break channels (A and B)
- The following can be set as break compare conditions:
  - 24 address bits
    - Bit masking possible
  - Bus cycle
    - Instruction fetch
    - Data access: data read, data write, data read/write
  - Bus master
    - Either CPU or CPU/DTC can be selected
- The timing of PC break exception handling after the occurrence of a break condition is as follows:
  - Immediately before execution of the instruction fetched at the set address (instruction fetch)
  - Immediately after execution of the instruction that accesses data at the set address (data access)
- Module stop mode can be set
  - The initial setting is for PBC operation to be halted. Register access is enabled by clearing module stop mode.

### 6.1.2 Block Diagram

Figure 6-1 shows a block diagram of the PC break controller.

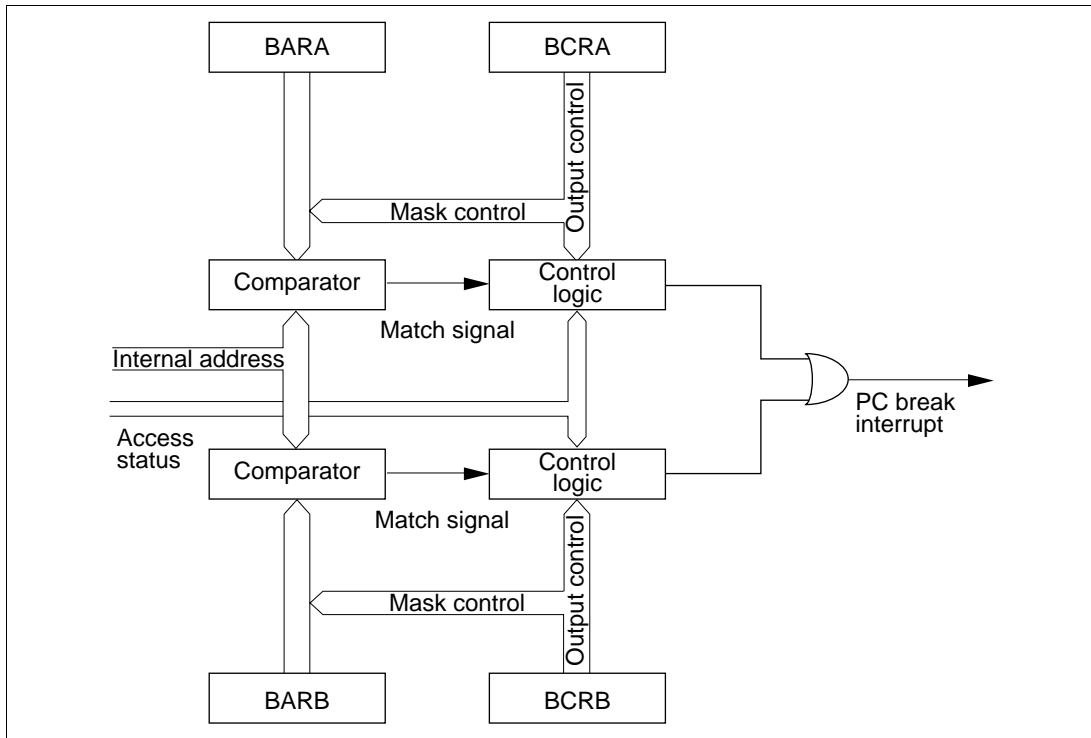


Figure 6-1 Block Diagram of PC Break Controller



### 6.1.3 Register Configuration

Table 6-1 shows the PC break controller registers.

**Table 6-1 PC Break Controller Registers**

Name	Abbreviation	R/W	Initial Value		Address* <sup>1</sup>
			Power-On Reset	Manual Reset	
Break address register A	BARA	R/W	H'XX000000	Retained	H'FE00
Break address register B	BARB	R/W	H'XX000000	Retained	H'FE04
Break control register A	BCRA	R/(W)* <sup>2</sup>	H'00	Retained	H'FE08
Break control register B	BCRB	R/(W)* <sup>2</sup>	H'00	Retained	H'FE09
Module stop control register C	MSTPCRC	R/W	H'FF	Retained	H'FDEA

Notes: \*1 Lower 16 bits of the address.

\*2 Only 0 can be written, for flag clearing.

## 6.2 Register Descriptions

### 6.2.1 Break Address Register A (BARA)

Bit	: 31	...	24	23	22	21	20	19	18	17	16	...	7	6	5	4	3	2	1	0
	—	...	—	BAA 23	BAA 22	BAA 21	BAA 20	BAA 19	BAA 18	BAA 17	BAA 16	...	BAA 7	BAA 6	BAA 5	BAA 4	BAA 3	BAA 2	BAA 1	BAA 0
Initial value:	Unde- fined	...	Unde- fined	0	0	0	0	0	0	0	0	...	0	0	0	0	0	0	0	0
R/W	—	...	—	R/W	R/W	R/W	R/W	R/W	R/W	R/W	R/W	...	R/W	R/W	R/W	R/W	R/W	R/W	R/W	R/W

BARA is a 32-bit readable/writable register that specifies the channel A break address.

BAA23 to BAA0 are initialized to H'000000 by a power-on reset and in hardware standby mode.

**Bits 31 to 24—Reserved:** These bits return an undefined value if read, and cannot be modified.

**Bits 23 to 0—Break Address A23 to A0 (BAA23–BAA0):** These bits hold the channel A PC break address.

## 6.2.2 Break Address Register B (BARB)

BARB is the channel B break address register. The bit configuration is the same as for BARA.

## 6.2.3 Break Control Register A (BCRA)

Bit	:	7	6	5	4	3	2	1	0
		CMFA	CDA	BAMRA2	BAMRA1	BAMRA0	CSELA1	CSELA0	BIEA
Initial value	:	0	0	0	0	0	0	0	0
R/W	:	R/(W)*	R/W	R/W	R/W	R/W	R/W	R/W	R/W

Note: \* Only 0 can be written, for flag clearing.

BCRA is an 8-bit readable/writable register that controls channel A PC breaks. BCRA (1) selects the break condition bus master, (2) specifies bits subject to address comparison masking, and (3) specifies whether the break condition is applied to an instruction fetch or a data access. It also contains a condition match flag.

BCRA is initialized to H'00 by a power-on reset and in hardware standby mode.

**Bit 7—Condition Match Flag A (CMFA):** Set to 1 when a break condition set for channel A is satisfied. This flag is not cleared to 0.

### Bit 7

CMFA	Description
0	[Clearing condition] When 0 is written to CMFA after reading CMFA = 1 (Initial value)
1	[Setting condition] When a condition set for channel A is satisfied

**Bit 6—CPU Cycle/DTC Cycle Select A (CDA):** Selects the channel A break condition bus master.

### Bit 6

CDA	Description
0	PC break is performed when CPU is bus master (Initial value)
1	PC break is performed when CPU or DTC is bus master

**Bits 5 to 3—Break Address Mask Register A2 to A0 (BAMRA2–BAMRA0):** These bits specify which bits of the break address (BAA23–BAA0) set in BARA are to be masked.

Bit 5	Bit 4	Bit 3	Description
BAMRA2	BAMRA1	BAMRA0	
0	0	0	All BARA bits are unmasked and included in break conditions (Initial value)
		1	BAA0 (lowest bit) is masked, and not included in break conditions
		1	BAA1–0 (lower 2 bits) are masked, and not included in break conditions
1	0	1	BAA2–0 (lower 3 bits) are masked, and not included in break conditions
		1	BAA3–0 (lower 4 bits) are masked, and not included in break conditions
	1	0	BAA7–0 (lower 8 bits) are masked, and not included in break conditions
		1	BAA11–0 (lower 12 bits) are masked, and not included in break conditions
		1	BAA15–0 (lower 16 bits) are masked, and not included in break conditions

**Bits 2 and 1—Break Condition Select A (CSELA1, CSELA0):** These bits selection an instruction fetch, data read, data write, or data read/write cycle as the channel A break condition.

Bit 2	Bit 1	Description
CSELA1	CSELA0	
0	0	Instruction fetch is used as break condition (Initial value)
	1	Data read cycle is used as break condition
1	0	Data write cycle is used as break condition
	1	Data read/write cycle is used as break condition

**Bits 0—Break Interrupt Enable A (BIEA):** Enables or disables channel A PC break interrupts.

Bit 0	Description
BIEA	
0	PC break interrupts are disabled (Initial value)
1	PC break interrupts are enabled

#### 6.2.4 Break Control Register B (BCRB)

BCRB is the channel B break control register. The bit configuration is the same as for BCRA.

#### 6.2.5 Module Stop Control Register C (MSTPCRC)

Bit	:	7	6	5	4	3	2	1	0
		MSTPC7	MSTPC6	MSTPC5	MSTPC4	MSTPC3	MSTPC2	MSTPC1	MSTPC0
Initial value	:	1	1	1	1	1	1	1	1
R/W	:	R/W	R/W	R/W	R/W	R/W	R/W	R/W	R/W

MSTPCRC is an 8-bit readable/writable register that performs module stop mode control.

When the MSTPC4 bit is set to 1, PC break controller operation is stopped at the end of the bus cycle, and module stop mode is entered. Register read/write accesses are not possible in module stop mode. For details, see section 24.5, Module Stop Mode.

MSTPCRC is initialized to H'FF by a power on reset and in hardware standby mode. It is not initialized by a manual reset and in software standby mode.

**Bit 4—Module Stop (MSTPC4):** Specifies the PC break controller module stop mode.

##### Bit 4

MSTPC4	Description
0	PC break controller module stop mode is cleared
1	PC break controller module stop mode is set (Initial value)

## 6.3 Operation

The operation flow from break condition setting to PC break interrupt exception handling is shown in sections 6.3.1, PC Break Interrupt Due to Instruction Fetch, and 6.3.2, PC Break Interrupt Due to Data Access, taking the example of channel A.

### 6.3.1 PC Break Interrupt Due to Instruction Fetch

#### (1) Initial settings

- Set the break address in BARA. For a PC break caused by an instruction fetch, set the address of the first instruction byte as the break address.
- Set the break conditions in BCRA.
  - BCRA bit 6 (CDA):** With a PC break caused by an instruction fetch, the bus master must be the CPU. Set 0 to select the CPU.
  - BCRA bits 5–3 (BAMA2–0):** Set the address bits to be masked.
  - BCRA bits 2–1 (CSELA1–0):** Set 00 to specify an instruction fetch as the break condition.
  - BCRA bit 0 (BIEA):** Set to 1 to enable break interrupts.

#### (2) Satisfaction of break condition

- When the instruction at the set address is fetched, a PC break request is generated immediately before execution of the fetched instruction, and the condition match flag (CMFA) is set.

#### (3) Interrupt handling

- After priority determination by the interrupt controller, PC break interrupt exception handling is started.

### 6.3.2 PC Break Interrupt Due to Data Access

#### (1) Initial settings

- Set the break address in BARA. For a PC break caused by a data access, set the target ROM, RAM, I/O, or external address space address as the break address. Stack operations and branch address reads are included in data accesses.
- Set the break conditions in BCRA.
  - BCRA bit 6 (CDA):** Select the bus master.
  - BCRA bits 5–3 (BAMA2–0):** Set the address bits to be masked.
  - BCRA bits 2–1 (CSELA1–0):** Set 01, 10, or 11 to specify data access as the break condition.
  - BCRA bit 0 (BIEA):** Set to 1 to enable break interrupts.

- (2) Satisfaction of break condition
  - After execution of the instruction that performs a data access on the set address, a PC break request is generated and the condition match flag (CMFA) is set.
- (3) Interrupt handling
  - After priority determination by the interrupt controller, PC break interrupt exception handling is started.

### **6.3.3 Notes on PC Break Interrupt Handling**

- (1) The PC break interrupt is shared by channels A and B. The channel from which the request was issued must be determined by the interrupt handler.
- (2) The CMFA and CMFB flags are not cleared to 0, so 0 must be written to CMFA or CMFB after first reading the flag while it is set to 1. If the flag is left set to 1, another interrupt will be requested after interrupt handling ends.
- (3) A PC break interrupt generated when the DTC is the bus master is accepted after the bus has been transferred to the CPU by the bus controller.

### **6.3.4 Operation in Transitions to Power-Down Modes**

The operation when a PC break interrupt is set for an instruction fetch at the address after a SLEEP instruction is shown below.

- (1) When the SLEEP instruction causes a transition from high-speed (medium-speed) mode to sleep mode, or from subactive mode to subsleep mode:  
After execution of the SLEEP instruction, a transition is not made to sleep mode or subsleep mode, and PC break interrupt handling is executed. After execution of PC break interrupt handling, the instruction at the address after the SLEEP instruction is executed (figure 6-2 (A)).
- (2) When the SLEEP instruction causes a transition from high-speed (medium-speed) mode to subactive mode:  
After execution of the SLEEP instruction, a transition is made to subactive mode via direct transition exception handling. After the transition, PC break interrupt handling is executed, then the instruction at the address after the SLEEP instruction is executed (figure 6-2 (B)).
- (3) When the SLEEP instruction causes a transition from subactive mode to high-speed (medium-speed) mode:

After execution of the SLEEP instruction, and following the clock oscillation settling time, a transition is made to high-speed (medium-speed) mode via direct transition exception handling. After the transition, PC break interrupt handling is executed, then the instruction at the address after the SLEEP instruction is executed (figure 6-2 (C)).

(4) When the SLEEP instruction causes a transition to software standby mode or watch mode:

After execution of the SLEEP instruction, a transition is made to the respective mode, and PC break interrupt handling is not executed. However, the CMFA or CMFB flag is set (figure 6-2 (D)).

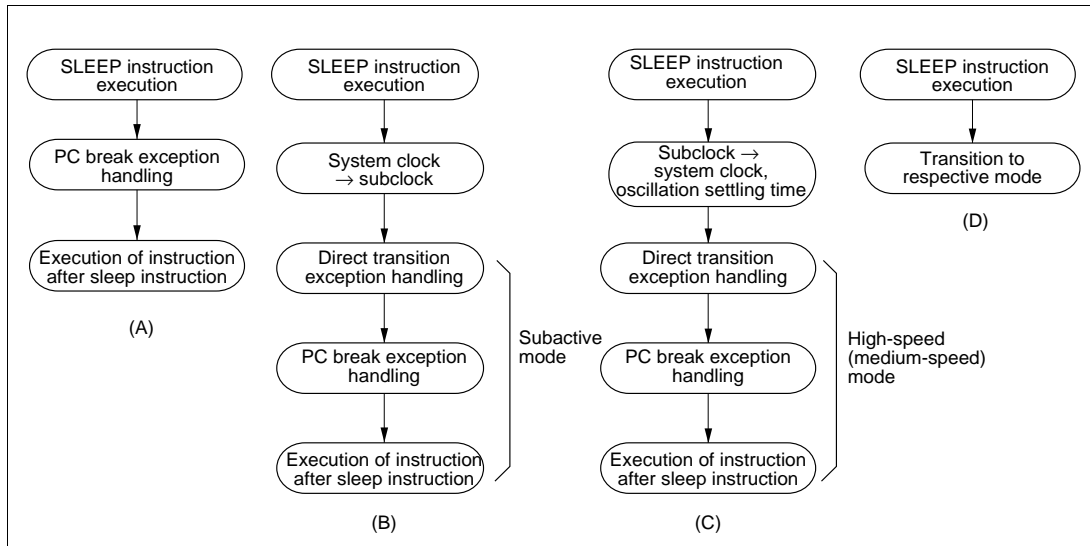


Figure 6-2 Operation in Power-Down Mode Transitions

### 6.3.5 PC Break Operation in Continuous Data Transfer

If a PC break interrupt is generated when the following operations are being performed, exception handling is executed on completion of the specified transfer.

(1) When a PC break interrupt is generated at the transfer address of an EEPMOV.B instruction:

PC break exception handling is executed after all data transfers have been completed and the EEPMOV.B instruction has ended.

(2) When a PC break interrupt is generated at a DTC transfer address:

PC break exception handling is executed after the DTC has completed the specified number of data transfers, or after data for which the DISEL bit is set to 1 has been transferred.

### 6.3.6 When Instruction Execution is Delayed by One State

Caution is required in the following cases, as instruction execution is one state later than usual.

- (1) When the PBC is enabled (i.e. when the break interrupt enable bit is set to 1), execution of a one-word branch instruction (Bcc d:8, BSR, JSR, JMP, TRAPA, RTE, or RTS) located in on-chip ROM or RAM is always delayed by one state.
- (2) When break interruption by instruction fetch is set, the set address indicates on-chip ROM or RAM space, and that address is used for data access, the instruction that executes the data access is one state later than in normal operation.
- (3) When break interruption by instruction fetch is set and a break interrupt is generated, if the executing instruction immediately preceding the set instruction has one of the addressing modes shown below, and that address indicates on-chip ROM or RAM, and that address is used for data access, the instruction will be one state later than in normal operation.  
@ERn, @(d:16,ERn), @(d:32,ERn), @-ERn/ERn+, @aa:8, @aa:24, @aa:32, @(d:8,PC), @(d:16,PC), @@aa:8
- (4) When break interruption by instruction fetch is set and a break interrupt is generated, if the executing instruction immediately preceding the set instruction is NOP or SLEEP, or has #xx,Rn as its addressing mode, and that instruction is located in on-chip ROM or RAM, the instruction will be one state later than in normal operation.



### 6.3.7 Additional Notes

- (1) When a PC break is set for an instruction fetch at the address following a BSR, JSR, JMP, TRAPA, RTE, or RTS instruction:

Even if the instruction at the address following a BSR, JSR, JMP, TRAPA, RTE, or RTS instruction is fetched, it is not executed, and so a PC break interrupt is not generated by the instruction fetch at the next address.

- (2) When the I bit is set by an LDC, ANDC, ORC, or XORC instruction, a PC break interrupt becomes valid two states after the end of the executing instruction. If a PC break interrupt is set for the instruction following one of these instructions, since interrupts, including NMI, are disabled for a 3-state period in the case of LDC, ANDC, ORC, and XORC, the next instruction is always executed. For details, see section 5, Interrupt Controller.

- (3) When a PC break is set for an instruction fetch at the address following a Bcc instruction:

A PC break interrupt is generated if the instruction at the next address is executed in accordance with the branch condition, but is not generated if the instruction at the next address is not executed.

- (4) When a PC break is set for an instruction fetch at the branch destination address of a Bcc instruction:

A PC break interrupt is generated if the instruction at the branch destination is executed in accordance with the branch condition, but is not generated if the instruction at the branch destination is not executed.



## Section 7 Bus Controller

### 7.1 Overview

The H8S/2633 Series has a built-in bus controller (BSC) that manages the external address space divided into eight areas. The bus specifications, such as bus width and number of access states, can be set independently for each area, enabling multiple memories to be connected easily.

The bus controller also has a bus arbitration function, and controls the operation of the internal bus masters: the CPU, DMA controller (DMAC)\*, and data transfer controller (DTC)\*.

Note: \* This function is not available in the H8S/2695.

#### 7.1.1 Features

The features of the bus controller are listed below.

- Manages external address space in area units
  - Manages the external space as 8 areas of 2-Mbytes
  - Bus specifications can be set independently for each area
  - DRAM/Burst ROM interface can be set
- Basic bus interface
  - Chip selects ( $\overline{CS0}$  to  $\overline{CS7}$ ) can be output for areas 0 to 7
  - 8-bit access or 16-bit access can be selected for each area
  - 2-state access or 3-state access can be selected for each area
  - Program wait states can be inserted for each area
- DRAM interface\*
  - DRAM interface can be set for areas 2 to 5 (in advanced mode)
  - Multiplexed output of row and column addresses (8/9/10-bit)
  - 2 CAS method
  - Burst operation (in high-speed mode)
  - Insertion of  $T_p$  cycle to secure RAS precharge time
  - Selection of CAS-before-RAS refresh and self refresh
- Burst ROM interface
  - Burst ROM interface can be set for area 0
  - Choice of 1- or 2-state burst access

- Idle cycle insertion
  - An idle cycle can be inserted in case of an external read cycle between different areas
  - An idle cycle can be inserted in case of an external write cycle immediately after an external read cycle
- Write buffer functions
  - External write cycle and internal access can be executed in parallel
  - DMAC\* single-address mode and internal access can be executed in parallel
- Bus arbitration function
  - Includes a bus arbiter that arbitrates bus mastership among the CPU, DMAC\* and DTC\*
- Other features
  - Refresh counter (refresh timer) can be used as an interval timer
  - External bus release function

Note: \* This function is not available in the H8S/2695.

## 7.1.2 Block Diagram

Figure 7-1 shows a block diagram of the bus controller.

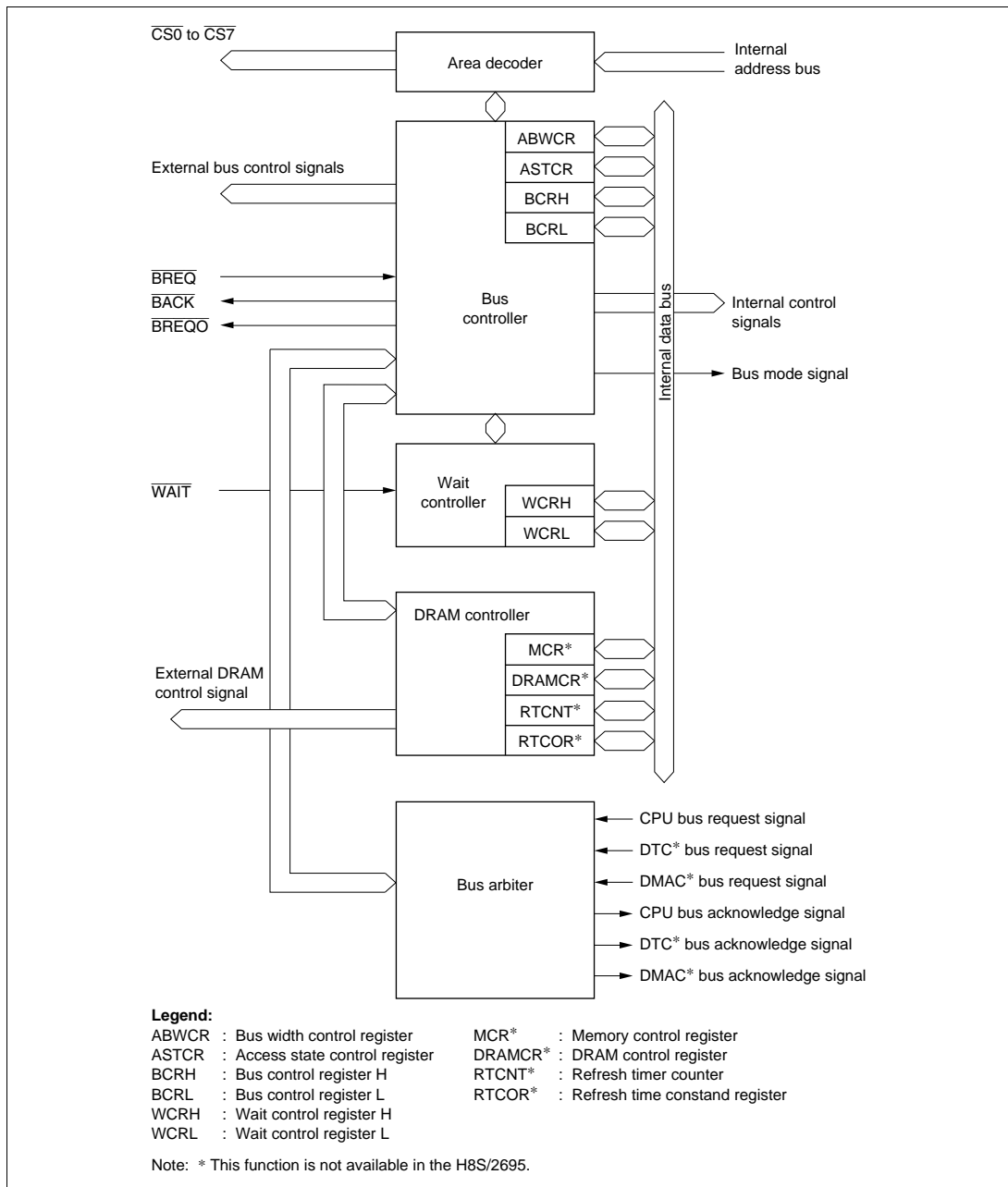


Figure 7-1 Block Diagram of Bus Controller

### 7.1.3 Pin Configuration

Table 7-1 summarizes the pins of the bus controller.

**Table 7-1 Bus Controller Pins**

Name	Symbol	I/O	Function
Address strobe	$\overline{AS}$	Output	Strobe signal indicating that address output on address bus is enabled.
Read	$\overline{RD}$	Output	Strobe signal indicating that external space is being read.
High write/ write enable*	$\overline{HWR}$	Output	Strobe signal indicating that external space is to be written, and upper half (D15 to D8) of data bus is enabled. 2CAS method DRAM with enable signal*.
Low write	$\overline{LWR}$	Output	Strobe signal indicating that external space is to be written, and lower half (D7 to D0) of data bus is enabled.
Chip select 0	$\overline{CS0}$	Output	Strobe signal showing selection of area 0
Chip select 1	$\overline{CS1}$	Output	Strobe signal showing selection of area 1
Chip select 2/row address strobe 2*	$\overline{CS2}$	Output	Strobe signal showing selection of area 2. When area 2 is allocated to DRAM space, this is the row address strobe signal for DRAM*. When areas 2 to 5 are contiguous DRAM space, this is the row address strobe signal for DRAM*.
Chip select 3/row address strobe 3*	$\overline{CS3}/\overline{OE}^*$	Output	Strobe signal showing selection of area 3. When area 3 is allocated to DRAM space, this is the row address strobe signal for DRAM*. When only area 2 is allocated to DRAM space, or when areas 2 to 5 are contiguous DRAM space, this is output enable signal*.
Chip select 4/row address strobe 4*	$\overline{CS4}$	Output	Strobe signal showing selection of area 4. When area 4 is allocated to DRAM space, this is the row address strobe signal for DRAM*.
Chip select 5/row address strobe 5*	$\overline{CS5}$	Output	Strobe signal showing selection of area 5. When area 5 is allocated to DRAM space, this is the row address strobe signal for DRAM*.
Chip select 6	$\overline{CS6}$	Output	Strobe signal showing selection of area 6
Chip select 7	$\overline{CS7}$	Output	Strobe signal showing selection of area 7
Upper column address strobe*	$\overline{CAS}^*$	Output	2 CAS method DRAM upper column address strobe signal*
Lower column strobe*	$\overline{LCAS}^*$	Output	DRAM lower column address strobe signal*

Note: \* This function is not available in the H8S/2695.

Name	Symbol	I/O	Function
Wait	$\overline{\text{WAIT}}$	Input	Wait request signal when accessing external 3-state access space.
Bus request	$\overline{\text{BREQ}}$	Input	Request signal that releases bus to external device.
Bus request acknowledge	$\overline{\text{BACK}}$	Output	Acknowledge signal indicating that bus has been released.
Bus request output	$\overline{\text{BREQO}}$	Output	External bus request signal used when internal bus master accesses external space when external bus is released.

#### 7.1.4 Register Configuration

Table 7-2 summarizes the registers of the bus controller.

**Table 7-2 Bus Controller Registers**

Name	Abbreviation	R/W	Initial Value		Address* <sup>1</sup>
			Power-On Reset	Manual Reset	
Bus width control register	ABWCR	R/W	H'FF/H'00* <sup>2</sup>	Retained	H'FED0
Access state control register	ASTCR	R/W	H'FF	Retained	H'FED1
Wait control register H	WCRH	R/W	H'FF	Retained	H'FED2
Wait control register L	WCRL	R/W	H'FF	Retained	H'FED3
Bus control register H	BCRH	R/W	H'D0	Retained	H'FED4
Bus control register L	BCRL	R/W	H'08	Retained	H'FED5
Pin function control register	PFCR	R/W	H'0D/H'00	Retained	H'FDEB
Memory control register	MCR* <sup>3</sup>	R/W	H'00	Retained	H'FED6
DRAM control register	DRAMCR* <sup>3</sup>	R/W	H'00	Retained	H'FED7
Refresh timer counter	RTCNT* <sup>3</sup>	R/W	H'00	Retained	H'FED8
Refresh time constant register	RTCOR* <sup>3</sup>	R/W	H'FF	Retained	H'FED9

Notes: \*1 Lower 16 bits of the address.

\*2 Determined by the MCU operating mode.

\*3 This function is not available in the H8S/2695.

## 7.2 Register Descriptions

### 7.2.1 Bus Width Control Register (ABWCR)

Bit	:	7	6	5	4	3	2	1	0
		ABW7	ABW6	ABW5	ABW4	ABW3	ABW2	ABW1	ABW0
Modes 5 to 7									
Initial value	:	1	1	1	1	1	1	1	1
R/W	:	R/W	R/W	R/W	R/W	R/W	R/W	R/W	R/W
Mode 4									
Initial value	:	0	0	0	0	0	0	0	0
R/W	:	R/W	R/W	R/W	R/W	R/W	R/W	R/W	R/W

ABWCR is an 8-bit readable/writable register that designates each area for either 8-bit access or 16-bit access.

ABWCR sets the data bus width for the external memory space. The bus width for on-chip memory and internal I/O registers is fixed regardless of the settings in ABWCR.

In normal mode, the settings of bits ABW7 to ABW1 have no effect on operation.

After a power-on reset and in hardware standby mode, ABWCR is initialized to H'FF in modes 5 to 7, and to H'00 in mode 4. It is not initialized by a manual reset or in software standby mode.

**Bits 7 to 0—Area 7 to 0 Bus Width Control (ABW7 to ABW0):** These bits select whether the corresponding area is to be designated for 8-bit access or 16-bit access.

Bit n	
ABWn	Description
0	Area n is designated for 16-bit access
1	Area n is designated for 8-bit access

(n = 7 to 0)



### 7.2.2 Access State Control Register (ASTCR)

Bit	:	7	6	5	4	3	2	1	0
		AST7	AST6	AST5	AST4	AST3	AST2	AST1	AST0
Initial value	:	1	1	1	1	1	1	1	1
R/W	:	R/W	R/W	R/W	R/W	R/W	R/W	R/W	R/W

ASTCR is an 8-bit readable/writable register that designates each area as either a 2-state access space or a 3-state access space.

ASTCR sets the number of access states for the external memory space. The number of access states for on-chip memory and internal I/O registers is fixed regardless of the settings in ASTCR.

In normal mode, the settings of bits AST7 to AST1 have no effect on operation.

ASTCR is initialized to H'FF by a power-on reset and in hardware standby mode. It is not initialized by a manual reset or in software standby mode.

**Bits 7 to 0—Area 7 to 0 Access State Control (AST7 to AST0):** These bits select whether the corresponding area is to be designated as a 2-state access space or a 3-state access space.

Wait state insertion is enabled or disabled at the same time.

Bit n		
ASTn	Description	
0	Area n is designated for 2-state access Wait state insertion in area n external space is disabled	
1	Area n is designated for 3-state access Wait state insertion in area n external space is enabled	(Initial value)

(n = 7 to 0)

### 7.2.3 Wait Control Registers H and L (WCRH, WCRL)

WCRH and WCRL are 8-bit readable/writable registers that select the number of program wait states for each area.

Program waits are not inserted in the case of on-chip memory or internal I/O registers.

WCRH and WCRL are initialized to H'FF by a power-on reset and in hardware standby mode. They are not initialized by a manual reset or in software standby mode.

#### (1) WCRH

Bit	:	7	6	5	4	3	2	1	0
		W71	W70	W61	W60	W51	W50	W41	W40
Initial value	:	1	1	1	1	1	1	1	1
R/W	:	R/W	R/W	R/W	R/W	R/W	R/W	R/W	R/W

**Bits 7 and 6—Area 7 Wait Control 1 and 0 (W71, W70):** These bits select the number of program wait states when area 7 in external space is accessed while the AST7 bit in ASTCR is set to 1.

Bit 7	Bit 6	Description
W71	W70	
0	0	Program wait not inserted when external space area 7 is accessed
	1	1 program wait state inserted when external space area 7 is accessed
1	0	2 program wait states inserted when external space area 7 is accessed
	1	3 program wait states inserted when external space area 7 is accessed (Initial value)

**Bits 5 and 4—Area 6 Wait Control 1 and 0 (W61, W60):** These bits select the number of program wait states when area 6 in external space is accessed while the AST6 bit in ASTCR is set to 1.

Bit 5	Bit 4	Description
W61	W60	
0	0	Program wait not inserted when external space area 6 is accessed
	1	1 program wait state inserted when external space area 6 is accessed
1	0	2 program wait states inserted when external space area 6 is accessed
	1	3 program wait states inserted when external space area 6 is accessed (Initial value)

**Bits 3 and 2—Area 5 Wait Control 1 and 0 (W51, W50):** These bits select the number of program wait states when area 5 in external space is accessed while the AST5 bit in ASTCR is set to 1.

Bit 3	Bit 2	
W51	W50	Description
0	0	Program wait not inserted when external space area 5 is accessed
	1	1 program wait state inserted when external space area 5 is accessed
1	0	2 program wait states inserted when external space area 5 is accessed
	1	3 program wait states inserted when external space area 5 is accessed (Initial value)

**Bits 1 and 0—Area 4 Wait Control 1 and 0 (W41, W40):** These bits select the number of program wait states when area 4 in external space is accessed while the AST4 bit in ASTCR is set to 1.

Bit 1	Bit 0	
W41	W40	Description
0	0	Program wait not inserted when external space area 4 is accessed
	1	1 program wait state inserted when external space area 4 is accessed
1	0	2 program wait states inserted when external space area 4 is accessed
	1	3 program wait states inserted when external space area 4 is accessed (Initial value)

## (2) WCRL

Bit	:	7	6	5	4	3	2	1	0
		W31	W30	W21	W20	W11	W10	W01	W00
Initial value	:	1	1	1	1	1	1	1	1
R/W	:	R/W	R/W	R/W	R/W	R/W	R/W	R/W	R/W

**Bits 7 and 6—Area 3 Wait Control 1 and 0 (W31, W30):** These bits select the number of program wait states when area 3 in external space is accessed while the AST3 bit in ASTCR is set to 1.

Bit 7	Bit 6	Description
W31	W30	
0	0	Program wait not inserted when external space area 3 is accessed
	1	1 program wait state inserted when external space area 3 is accessed
1	0	2 program wait states inserted when external space area 3 is accessed
	1	3 program wait states inserted when external space area 3 is accessed (Initial value)

**Bits 5 and 4—Area 2 Wait Control 1 and 0 (W21, W20):** These bits select the number of program wait states when area 2 in external space is accessed while the AST2 bit in ASTCR is set to 1.

Bit 5	Bit 4	Description
W21	W20	
0	0	Program wait not inserted when external space area 2 is accessed
	1	1 program wait state inserted when external space area 2 is accessed
1	0	2 program wait states inserted when external space area 2 is accessed
	1	3 program wait states inserted when external space area 2 is accessed (Initial value)

**Bits 3 and 2—Area 1 Wait Control 1 and 0 (W11, W10):** These bits select the number of program wait states when area 1 in external space is accessed while the AST1 bit in ASTCR is set to 1.

Bit 3	Bit 2	Description
W11	W10	
0	0	Program wait not inserted when external space area 1 is accessed
	1	1 program wait state inserted when external space area 1 is accessed
1	0	2 program wait states inserted when external space area 1 is accessed
	1	3 program wait states inserted when external space area 1 is accessed (Initial value)

**Bits 1 and 0—Area 0 Wait Control 1 and 0 (W01, W00):** These bits select the number of program wait states when area 0 in external space is accessed while the AST0 bit in ASTCR is set to 1.

Bit 1	Bit 0	Description
W01	W00	
0	0	Program wait not inserted when external space area 0 is accessed
	1	1 program wait state inserted when external space area 0 is accessed
1	0	2 program wait states inserted when external space area 0 is accessed
	1	3 program wait states inserted when external space area 0 is accessed (Initial value)

#### 7.2.4 Bus Control Register H (BCRH)

Bit	:	7	6	5	4	3	2	1	0
		ICIS1	ICIS0	BRSTRM	BRSTS1	BRSTS0	RMTS2*	RMTS1*	RMTS0*
Initial value	:	1	1	0	1	0	0	0	0
R/W	:	R/W	R/W	R/W	R/W	R/W	R/W	R/W	R/W

BCRH is an 8-bit readable/writable register that selects enabling or disabling of idle cycle insertion, and the memory interface for area 0.

BCRH is initialized to H'D0 by a power-on reset and in hardware standby mode. It is not initialized by a manual reset or in software standby mode.

Note: \* DRAM interface is not available in the H8S/2695.

Only a 0 may be written to RMTS2, RMTS1, or RMTS0.

**Bit 7—Idle Cycle Insert 1 (ICIS1):** Selects whether or not one idle cycle state is to be inserted between bus cycles when successive external read cycles are performed in different areas.

**Bit 7**

ICIS1	Description
0	Idle cycle not inserted in case of successive external read cycles in different areas
1	Idle cycle inserted in case of successive external read cycles in different areas (Initial value)

**Bit 6—Idle Cycle Insert 0 (ICIS0):** Selects whether or not one idle cycle state is to be inserted between bus cycles when successive external read and external write cycles are performed .

**Bit 6**

ICIS0	Description
0	Idle cycle not inserted in case of successive external read and external write cycles
1	Idle cycle inserted in case of successive external read and external write cycles (Initial value)

**Bit 5—Burst ROM Enable (BRSTRM):** Selects whether area 0 is used as a burst ROM interface.

**Bit 5**

BRSTRM	Description
0	Area 0 is basic bus interface (Initial value)
1	Area 0 is burst ROM interface

**Bit 4—Burst Cycle Select 1 (BRSTS1):** Selects the number of burst cycles for the burst ROM interface.

**Bit 4**

BRSTS1	Description
0	Burst cycle comprises 1 state
1	Burst cycle comprises 2 states (Initial value)

**Bit 3—Burst Cycle Select 0 (BRSTS0):** Selects the number of words that can be accessed in a burst ROM interface burst access.

**Bit 3**

BRSTS0	Description
0	Max. 4 words in burst access (Initial value)
1	Max. 8 words in burst access

**Bits 2 to 0—RAM Type Select (RMTS2 to RMTS0):** In advanced mode, these bits select the memory interface for areas 2 to 5.

When DRAM space\* is selected, the appropriate area becomes the DRAM interface\*.

Note: \* This function is not available in the H8S/2695.

Only a 0 may be written to RMTS2, RMTS1, or RMTS0.

Bit 2	Bit 1	Bit 0	Description			
RMTS2	RMTS1	RMTS0	Area 5	Area 4	Area 3	Area 2
0	0	0	Normal space	Normal space	Normal space	Normal space
		1	Normal space	Normal space	Normal space	DRAM space
	1	0	Normal space	Normal space	DRAM space	DRAM space
		1	DRAM space	DRAM space	DRAM space	DRAM space
1	1	1	Contiguous DRAM space	Contiguous DRAM space	Contiguous DRAM space	Contiguous DRAM space

Note: When all areas selected in DRAM are 8-bit space, the PF2 pin can be used as an I/O port and for  $\overline{\text{BREQ}}$  and  $\overline{\text{WAIT}}$ . When contiguous RAM is selected set the appropriate bus width and number of access states (the number of programmable waits) to the same values for all of areas 2 to 5. Do not set other than the above combinations.

### 7.2.5 Bus Control Register L (BCRL)

Bit	:	7	6	5	4	3	2	1	0
		BRLE	BREQOE	—	OES*	DDS*	RCTS*	WDBE	WAITE
Initial value	:	0	0	0	0	1	0	0	0
R/W	:	R/W	R/W	—	R/W	R/W	R/W	R/W	R/W

Note: \* This function is not available in the H8S/2695.

BCRL is an 8-bit readable/writable register that performs selection of the external bus-released state protocol, enabling or disabling of the write data buffer function, and enabling or disabling of  $\overline{\text{WAIT}}$  pin input.

BCRL is initialized to H'08 by a power-on reset and in hardware standby mode. It is not initialized by a manual reset or in software standby mode.

**Bit 7—Bus Release Enable (BRLE):** Enables or disables external bus release.

#### Bit 7

BRLE	Description
0	External bus release is disabled. $\overline{\text{BREQ}}$ , $\overline{\text{BACK}}$ and $\overline{\text{BREQO}}$ can be used as I/O ports (Initial value)
1	External bus release is enabled

**Bit 6—BREQO Pin Enable (BREQOE):** Outputs a signal that requests the external bus master to drop the bus request signal ( $\overline{\text{BREQ}}$ ) in the external bus release state, when an internal bus master performs an external space access, or when a refresh request is generated.

#### Bit 6

BREQOE	Description
0	$\overline{\text{BREQO}}$ output disabled. $\overline{\text{BREQO}}$ can be used as I/O port (Initial value)
1	$\overline{\text{BREQO}}$ output enabled

**Bit 5—Reserved:** This bit cannot be modified and is always read as 0.



**Bit 4—OE Select (OES):** Selects the  $\overline{CS3}$  pin as the  $\overline{OE}$  pin.

**Bit 4**

OES	Description
0	Uses the $\overline{CS3}$ pin as the port or as $\overline{CS3}$ signal output (Initial value)
1	When only area 2 is set for DRAM, or when areas 2 to 5 are set as contiguous DRAM space, the $\overline{CS3}$ pin is used as the $\overline{OE}$ pin

**Bit 3—DACK Timing Select (DDS):** When using the DRAM interface, this bit selects the DMAC single address transfer bus timing.

**Bit 3**

DDS	Description
0	When performing DMAC single address transfers to DRAM, always execute full access. The $\overline{DACK}$ signal is output as a low-level signal from the $T_r$ or $T_1$ cycle
1	Burst access is also possible when performing DMAC single address transfers to DRAM. The $\overline{DACK}$ signal is output as a low-level signal from the $T_{C1}$ or $T_2$ cycle (Initial value)

**Bit 2—Read CAS Timing Select (RCTS):** Selects the  $\overline{CAS}$  signal output timing.

**Bit 2**

RCTS	Description
0	$\overline{CAS}$ signal output timing is same when reading and writing (Initial value)
1	When reading, $\overline{CAS}$ signal is asserted half cycle earlier than when writing

**Bit 1—Write Data Buffer Enable (WDBE):** This bit selects whether or not to use the write buffer function in the external write cycle or the DMAC\* single address cycle.

**Bit 1**

WDBE	Description
0	Write data buffer function not used (Initial value)
1	Write data buffer function used

**Bit 0—WAIT Pin Enable (WAITE):** Selects enabling or disabling of wait input by the  $\overline{\text{WAIT}}$  pin.

**Bit 0**

WAITE	Description
0	Wait input by $\overline{\text{WAIT}}$ pin disabled. $\overline{\text{WAIT}}$ pin can be used as I/O port (Initial value)
1	Wait input by $\overline{\text{WAIT}}$ pin enabled

**7.2.6 Pin Function Control Register (PFCR)**

Bit	:	7	6	5	4	3	2	1	0
		CSS07	CSS36	BUZZE*	LCASS*	AE3	AE2	AE1	AE0
Initial value :		0	0	0	0	1/0	1/0	0	1/0
R/W :		R/W	R/W	R/W	R/W	R/W	R/W	R/W	R/W

Note: \* This function is not available in the H8S/2695. Only 0 should be written to the BUZZE and LCASS bits.

PFCR is an 8-bit read/write register that controls the CS selection of pins PG4 and PG1, controls LCAS selection of pins PF2 and PF6, and controls the address output in expanded mode with ROM.

PFCR is initialized to H'0D/H'00 by a power-on reset and in hardware standby mode. It retains its previous state by a manual reset or in software standby mode.

**Bit 7— $\overline{\text{CS0}}/\overline{\text{CS7}}$  Select (CSS07):** This bit selects the contents of CS output via the PG4 pin. In modes 4, 5, and 6, setting the corresponding DDR to 1 outputs the selected CS.

**Bit 7**

CSS07	Description
0	Selects $\overline{\text{CS0}}$ (Initial value)
1	Selects $\overline{\text{CS7}}$

**Bit 6— $\overline{\text{CS3}}/\overline{\text{CS6}}$  Select (CSS36):** This bit selects the contents of CS output via the PG1 pin. In modes 4, 5, and 6, setting the corresponding DDR to 1 outputs the selected CS.

**Bit 6**

CSS36	Description
0	Selects $\overline{\text{CS3}}$ (Initial value)
1	Selects $\overline{\text{CS6}}$

**Bit 5—BUZZ Output Enable (BUZZE):** This bit enables/disables BUZZ output via the PF1 pin. The WDT1 input clock, selected with PSS and CKS2 to CKS0, is output as the BUZZ signal. See section 15.2.4, Pin Function Control Register (PFCR) for details of BUZZ output.

**Bit 5**

<b>BUZZE</b>	<b>Description</b>	
0	Functions as PF1 input pin	(Initial value)
1	Functions as BUZZ output pin	

**Bit 4—LCAS Output Pin Select Bit (LCASS):** Selects output pin for LCAS signal.

**Bit 4**

<b>LCASS</b>	<b>Description</b>	
0	Outputs LCAS signal from PF2	(Initial value)
1	Outputs LCAS signal from PF6	

**Bits 3 to 0—Address Output Enable 3 to 0 (AE3–AE0):** These bits select enabling or disabling of address outputs A8 to A23 in ROMless expanded mode and modes with ROM. When a pin is enabled for address output, the address is output regardless of the corresponding DDR setting. When a pin is disabled for address output, it becomes an output port when the corresponding DDR bit is set to 1.

Bit 3	Bit 2	Bit 1	Bit 0	Description
AE3	AE2	AE1	AE0	
0	0	0	0	A8–A23 address output disabled (Initial value*)
			1	A8 address output enabled; A9–A23 address output disabled
		1	0	A8, A9 address output enabled; A10–A23 address output disabled
			1	A8–A10 address output enabled; A11–A23 address output disabled
	1	0	0	A8–A11 address output enabled; A12–A23 address output disabled
			1	A8–A12 address output enabled; A13–A23 address output disabled
		1	0	A8–A13 address output enabled; A14–A23 address output disabled
			1	A8–A14 address output enabled; A15–A23 address output disabled
1	0	0	0	A8–A15 address output enabled; A16–A23 address output disabled
			1	A8–A16 address output enabled; A17–A23 address output disabled
		1	0	A8–A17 address output enabled; A18–A23 address output disabled
			1	A8–A18 address output enabled; A19–A23 address output disabled
	1	0	0	A8–A19 address output enabled; A20–A23 address output disabled
			1	A8–A20 address output enabled; A21–A23 address output disabled (Initial value*)
		1	0	A8–A21 address output enabled; A22, A23 address output disabled
			1	A8–A23 address output enabled

Note: \* In expanded mode with ROM, bits AE3 to AE0 are initialized to B'0000.

In ROMless expanded mode, bits AE3 to AE0 are initialized to B'1101.

Address pins A0 to A7 are made address outputs by setting the corresponding DDR bits to 1.

### 7.2.7 Memory Control Register (MCR)\*

Bit	:	7	6	5	4	3	2	1	0
		TPC	BE	RCDM	CW2	MXC1	MXC0	RLW1	RLW0
Initial value	:	0	0	0	0	0	0	0	0
R/W	:	R/W	R/W	R/W	R/W	R/W	R/W	R/W	R/W

The MCR is an 8-bit read/write register that, when areas 2 to 5 are set as the DRAM interface, controls the DRAM strobe method, number of precharge cycles, access mode, address multiplex shift amount, and number of wait states to be inserted when a refresh is performed.

The MCR is initialized to H'00 at a power-on reset and in hardware standby mode. It is not initialized at a manual reset or in software standby mode.

Note: \* This function is not available in the H8S/2695.

**Bit 7—TP Cycle Control (TPC):** When accessing areas 2 to 5, allocated to DRAM, this bit selects whether the precharge cycle ( $T_p$ ) is 1 state or 2 states.

#### Bit 7

TPC	Description
0	Insert 1 precharge cycle (Initial value)
1	Insert 2 precharge cycles

**Bit 6—Burst Access Enable (BE):** This bit enables/disables burst access of areas 2 to 5, allocated as DRAM space. DRAM space burst access is in high-speed page mode. When using EDO type in this case, either select OE output or RAS up mode.

#### Bit 6

BE	Description
0	Burst disabled (always full access) (Initial value)
1	Access DRAM space in high-speed page mode

**Bit 5—RAS Down Mode (RCDM):** When areas 2 to 5 are allocated to DRAM space, this bit selects whether the  $\overline{\text{RAS}}$  signal level remains Low while waiting for the next DRAM access (RAS down mode) or the  $\overline{\text{RAS}}$  signal level returns to High (RAS up mode), when DRAM access is discontinued.

**Bit 5**

RCDM	Description
0	DRAM interface: selects RAS up mode (Initial value)
1	DRAM interface: selects RAS down mode

**Bit 4—Reserved (CW2):** Only write 0 to this bit.

**Bits 3 and 2—Multiplex shift counts 1 and 0 (MXC1 and MXC0):** These bits select the shift amount to the low side of the row address of the multiplexed row/column address in DRAM interface mode. They also select the row address to be compared in burst operation of the DRAM interface.

Bit 3 MXC1	Bit 2 MXC0	Description
0	0	8-bit shift (Initial value) (1) 8-bit access space: target row addresses for comparison are A23 to A8 (2) 16-bit access space: target row addresses for comparison are A23 to A9
	1	9-bit shift (1) 8-bit access space: target row addresses for comparison are A23 to A9 (2) 16-bit access space: target row addresses for comparison are A23 to A10
1	0	10-bit shift (1) 8-bit access space: target row addresses for comparison are A23 to A10 (2) 16-bit access space: target row addresses for comparison are A23 to A11
	1	—

**Bits 1 and 0—Refresh Cycle Wait Control 1 and 0 (RLW1 and RLW0):** These bits select the number of wait states to be inserted in the CAS-before-RAS refresh cycle of the DRAM interface. The selected number of wait states is applied to all areas set as DRAM space. Wait input via the WAIT pin is disabled.

Bit 1 RLW1	Bit 0 RLW0	Description
0	0	Do not insert wait state (Initial value)
	1	Insert 1 wait state
1	0	Insert 2 wait states
	1	Insert 3 wait states

## 7.2.8 DRAM Control Register (DRAMCR)\*

Bit	:	7	6	5	4	3	2	1	0
		RFSHE	CBRM	RMODE	CMF	CMIE	CKS2	CKS1	CKS0
Initial value	:	0	0	0	0	0	0	0	0
R/W	:	R/W	R/W	R/W	R/W	R/W	R/W	R/W	R/W

The DRAMCR is an 8-bit read/write register that selects DRAM refresh mode, the refresh counter clock, and sets the refresh timer control.

The DRAMCR is initialized to H'00 at a power-on reset and in hardware standby mode. It is not initialized at a manual reset or in software standby mode.

Note: \* This function is not available in the H8S/2695.

**Bit 7—Refresh Control (RFSHE):** This bit selects whether or not to perform refresh control. When not performing refresh control, the refresh timer can be used as an interval timer.

### Bit 7

RFSHE	Description
0	Do not perform refresh control (Initial value)
1	Perform refresh control

**Bit 6—CBR Refresh Mode (CBRM):** This bit selects whether CBR refresh is performed in parallel with other external access, or only CBR refresh is performed.

### Bit 6

CBRM	Description
0	Enables external access during CAS-before-RAS refresh (Initial value)
1	Disables external access during CAS-before-RAS refresh

**Bit 5—Refresh Mode (RMODE):** This bit selects whether or not to perform a self refresh in software standby mode when performing refresh control (RFSHE=1).

### Bit 5

RMODE	Description
0	Do not perform self-refresh in software standby mode (Initial value)
1	Perform self-refresh in software standby mode

**Bit 4—Compare Match Flag (CMF):** This status flag shows a match between RTCNT and RTCOR values.

When performing refresh control (RFSHE=1), write 1 to CMF when writing to the DRAMCR.

**Bit 4**

CMF	Description
0	[Clearing] When CMF=1, read the CMF flag, then clear the CMF flag to 0 (Initial value)
1	[Setting] CMF is set when RTCNT=RTCOR

**Bit 3—Compare Match Interrupt Enable (CMIE):** This bit enables/disables the CMF flag interrupt request (CMI) when the DRAMCR CMF flag is set to 1.

CMIE is always 0 when performing refresh control (RFSHE = 1).

**Bit 3**

CMIE	Description
0	Disables CMF flag interrupt requests (CMI) (Initial value)
1	Enables CMF flag interrupt requests (CMI)

**Bits 2 to 0—Refresh Counter Clock Select (CKS2 to CKS0):** These bits select from the seven internal clocks derived by dividing the system clock ( $\phi$ ) to be input to RTCNT. The RTCNT count up starts when CKS2 to CKS0 are set to select the input clock.

Bit 2	Bit 1	Bit 0	Description
CKS2	CKS1	CKS0	
0	0	0	Stops count (Initial value)
		1	Counts on $\phi/2$
	1	0	Counts on $\phi/8$
		1	Counts on $\phi/32$
1	0	0	Counts on $\phi/128$
		1	Counts on $\phi/512$
	1	0	Counts on $\phi/2048$
		1	Counts on $\phi/4096$



### 7.2.9 Refresh Timer Counter (RTCNT)\*

Bit	:	7	6	5	4	3	2	1	0
Initial value :		0	0	0	0	0	0	0	0
R/W	:	R/W	R/W	R/W	R/W	R/W	R/W	R/W	R/W

RTCNT is an 8-bit read/write up-counter.

RTCNT counts up using the internal clock selected by the DRAMCR CKS2 to CKS0 bits.

When RTCNT matches the value in RTCOR (compare match), the DRAMCR CMF flag is set to 1 and RTCNT is cleared to H'00. If, at this point, DRAMCR RFSHE is set to 1, the refresh cycle starts. When the DRAMCR CMIE bit is set to 1, a compare match interrupt (CMI) is also generated.

RTCNT is initialized to H'00 at a power-on reset and in hardware standby mode. It is not initialized at a manual reset or in software standby mode.

Note: \* This function is not available in the H8S/2695.

### 7.2.10 Refresh Time Constant Register (RTCOR)\*

Bit	:	7	6	5	4	3	2	1	0
Initial value :		1	1	1	1	1	1	1	1
R/W	:	R/W	R/W	R/W	R/W	R/W	R/W	R/W	R/W

RTCOR is an 8-bit read/write register that sets the RTCNT compare match cycle.

The values of RTCOR and RTCNT are constantly compared and, when both value match, the DRAMCR CMF flag is set to 1 and RTCNT is cleared to H'00.

RTCOR is initialized to H'FF at a power-on reset and in hardware standby mode. It is not initialized at a manual reset or in software standby mode.

Note: \* This function is not available in the H8S/2695.

## 7.3 Overview of Bus Control

### 7.3.1 Area Partitioning

In advanced mode, the bus controller partitions the 16 Mbytes address space into eight areas, 0 to 7, in 2-Mbyte units, and performs bus control for external space in area units. A chip select signal ( $\overline{CS0}$  to  $\overline{CS7}$ ) can be output for each area. In normal mode\*, it controls a 64-kbyte address space comprising part of area 0. Figure 7-2 shows an outline of the memory map.

Note: \* Not available in the H8S/2633 Series.

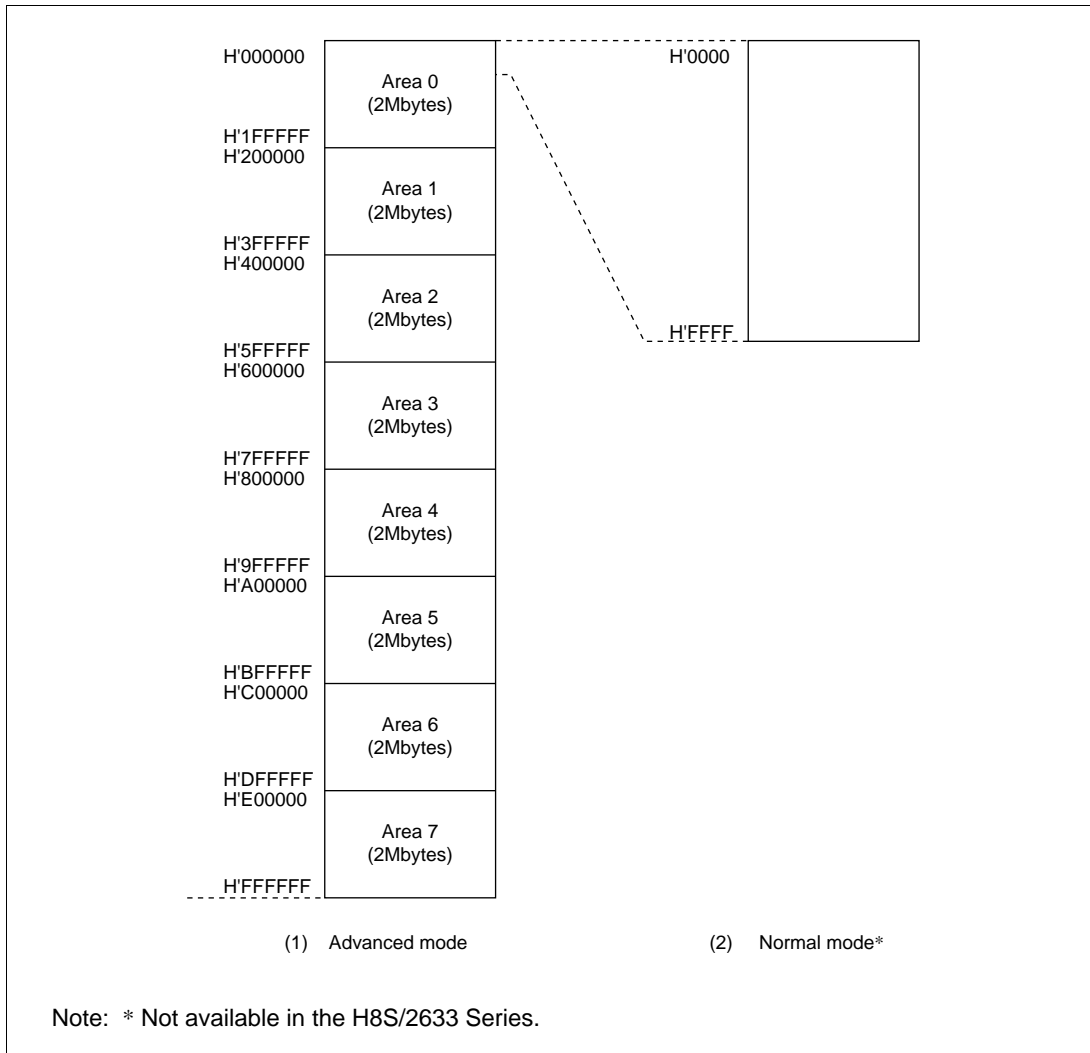


Figure 7-2 Overview of Area Partitioning

### 7.3.2 Bus Specifications

The external space bus specifications consist of three elements: bus width, number of access states, and number of program wait states.

The bus width and number of access states for on-chip memory and internal I/O registers are fixed, and are not affected by the bus controller.

**(1) Bus Width:** A bus width of 8 or 16 bits can be selected with ABWCR. An area for which an 8-bit bus is selected functions as an 8-bit access space, and an area for which a 16-bit bus is selected functions as a 16-bit access space.

If all areas are designated for 8-bit access, 8-bit bus mode is set; if any area is designated for 16-bit access, 16-bit bus mode is set. When the burst ROM interface is designated, 16-bit bus mode is always set.

**(2) Number of Access States:** Two or three access states can be selected with ASTCR. An area for which 2-state access is selected functions as a 2-state access space, and an area for which 3-state access is selected functions as a 3-state access space.

With the DRAM interface\* or the burst ROM interface, the number of access states may be determined without regard to ASTCR.

When 2-state access space is designated, wait insertion is disabled.

Note: \* This function is not available in the H8S/2695.

**(3) Number of Program Wait States:** When 3-state access space is designated by ASTCR, the number of program wait states to be inserted automatically is selected with WCRH and WCRL. From 0 to 3 program wait states can be selected.

Table 7-3 shows the bus specifications for each basic bus interface area.

**Table 7-3 Bus Specifications for Each Area (Basic Bus Interface)**

ABWCR	ASTCR	WCRH, WCRL		Bus Specifications (Basic Bus Interface)			
				Bus Width	Access States	Program Wait States	
ABWn	ASTn	Wn1	Wn0				
0	0	—	—	16	2	0	
	1	0	0		0	3	0
			1		1		1
			1		0		2
					1		3
1	0	—	—	8	2	0	
	1	0	0		0	3	0
			1		1		
			1		0		2
					1		3

### 7.3.3 Memory Interfaces

The H8S/2633 Series memory interfaces comprise a basic bus interface that allows direct connection or ROM, SRAM, and so on, DRAM interface\* with direct DRAM connection and a burst ROM interface that allows direct connection of burst ROM. The memory interface can be selected independently for each area.

An area for which the basic bus interface is designated functions as normal space, and areas set for DRAM interface are DRAM spaces an area for which the burst ROM interface is designated functions as burst ROM space.

Note: \* This function is not available in the H8S/2695.

### 7.3.4 Interface Specifications for Each Area

The initial state of each area is basic bus interface, 3-state access space. The initial bus width is selected according to the operating mode. The bus specifications described here cover basic items only, and the sections on each memory interface (section 7.4, Basic Bus Interface, section 7.5, DRAM Interface, and section 7.7, Burst ROM Interface) should be referred to for further details.

**Area 0:** Area 0 includes on-chip ROM, and in ROM-disabled expansion mode, all of area 0 is external space. In ROM-enabled expansion mode, the space excluding on-chip ROM is external space.

A  $\overline{CS0}$  signal can be output when accessing area 0 external space.

Either basic bus interface or burst ROM interface can be selected for area 0.

**Areas 1 and 6:** In external expansion mode, all of areas 1 and 6 is external space.

$\overline{CS1}$  and  $\overline{CS6}$  pin signals can be output when accessing the area 1 and 6 external space.

Only the basic bus interface can be used for areas 1 and 6.

**Areas 2 to 5:** In external expansion mode, all of areas 2 to 5 is external space.

$\overline{CS2}$  to  $\overline{CS5}$  signals can be output when accessing area 2 to 5 external space.

The standard bus interface or DRAM interface\* can be selected for areas 2 to 5. In DRAM interface mode, signals  $\overline{CS2}$  to  $\overline{CS5}$  are used as  $\overline{RAS}$  signals.

Note: \* This function is not available in the H8S/2695.

**Area 7:** Area 7 includes the on-chip RAM and internal I/O registers. In external expansion mode, the space excluding the on-chip RAM and internal I/O registers is external space. The on-chip RAM is enabled when the RAME bit in the system control register (SYSCR) is set to 1; when the RAME bit is cleared to 0, the on-chip RAM is disabled and the corresponding space becomes external space.

A  $\overline{CS7}$  signal can be output when accessing area 7 external space.

Only the basic bus interface can be used for the area 7.

### 7.3.5 Chip Select Signals

This LSI allows chip select signals ( $\overline{CS0}$  to  $\overline{CS7}$ ) to be output for each of areas 0 to 7. The level of these signals is set Low when accessing the external space of the respective area.

Figure 7-3 shows example  $\overline{CSn}$  (where n=0 to 7) signal output timing.

The output of the  $\overline{CSn}$  signal can be enabled or disabled by the data direction register (DDR) of the port of the corresponding  $\overline{CSn}$  pin.

In ROM-disabled expanded mode, the  $\overline{CS0}$  pin is set for output after a power-on reset. The  $\overline{CS1}$  to  $\overline{CS7}$  pins are set for input after a power-on reset, so the corresponding DDR must be set to 1 to allow the output of  $\overline{CS1}$  to  $\overline{CS7}$  signals.

In ROM-disabled expanded mode, all of pins  $\overline{CS0}$  to  $\overline{CS7}$  are set for input after a power-on reset, so the corresponding DDR must be set to 1 to allow the output of  $\overline{CS0}$  to  $\overline{CS7}$  signals.

See sections 10A and 10B, I/O Ports for details.

When areas 2 to 5 are set as DRAM\* space,  $\overline{CS2}$  to  $\overline{CS5}$  outputs are used as  $\overline{RAS}$  signals.

Note: \* DRAM interface is not available in the H8S/2695.

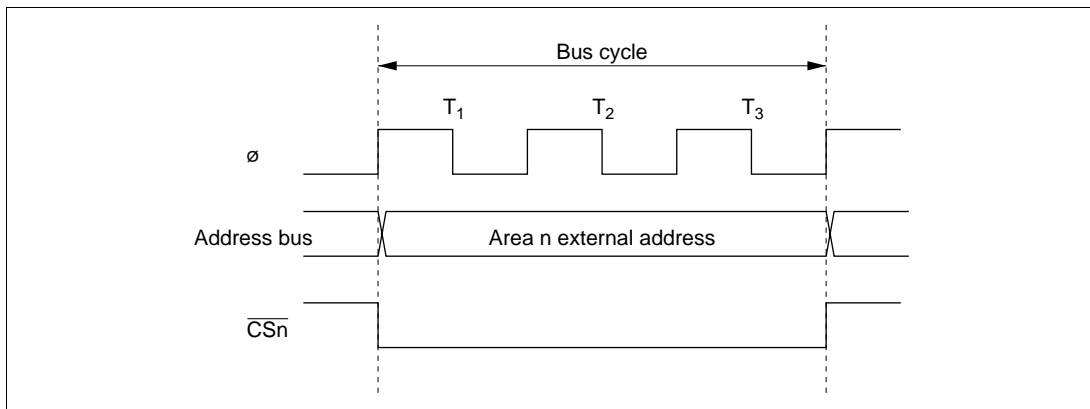


Figure 7-3  $\overline{CSn}$  Signal Output Timing (where n=0 to 7)

## 7.4 Basic Bus Interface

### 7.4.1 Overview

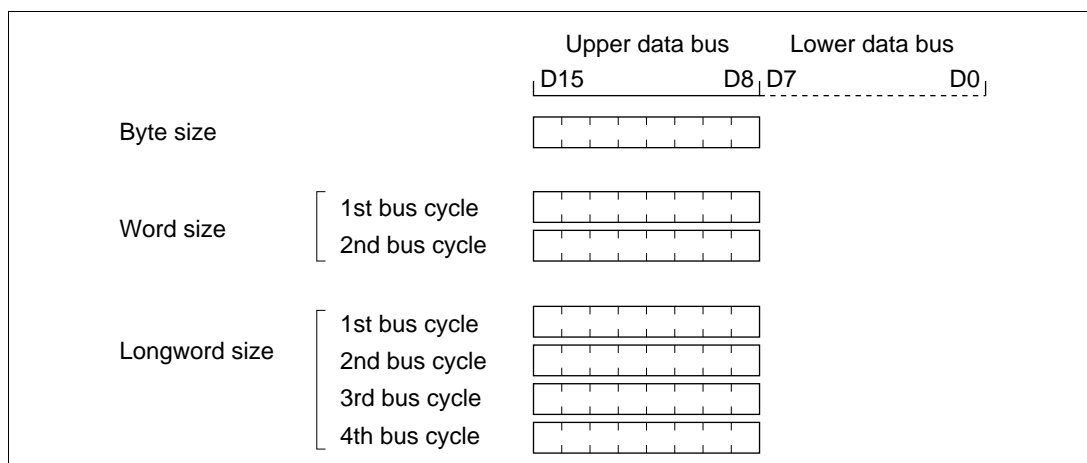
The basic bus interface enables direct connection of ROM, SRAM, and so on.

The bus specifications can be selected with ABWCR, ASTCR, WCRH, and WCRL (see table 7-3).

### 7.4.2 Data Size and Data Alignment

Data sizes for the CPU and other internal bus masters are byte, word, and longword. The bus controller has a data alignment function, and when accessing external space, controls whether the upper data bus (D15 to D8) or lower data bus (D7 to D0) is used according to the bus specifications for the area being accessed (8-bit access space or 16-bit access space) and the data size.

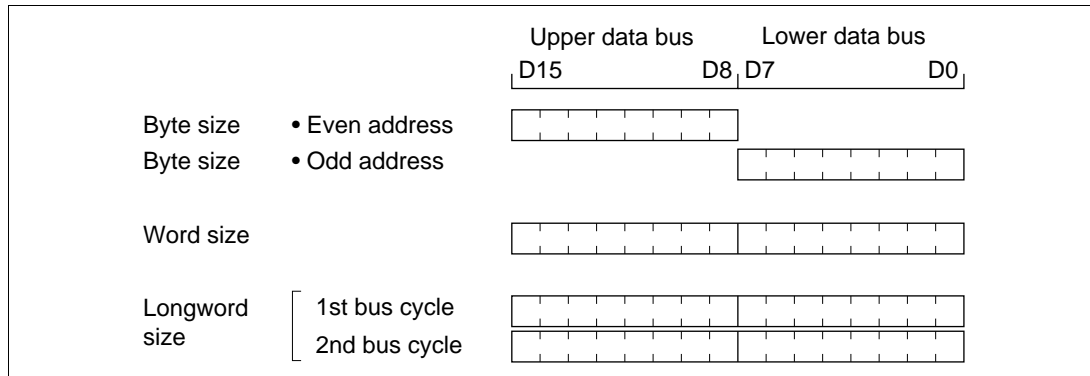
**8-Bit Access Space:** Figure 7-4 illustrates data alignment control for the 8-bit access space. With the 8-bit access space, the upper data bus (D15 to D8) is always used for accesses. The amount of data that can be accessed at one time is one byte: a word transfer instruction is performed as two byte accesses, and a longword transfer instruction, as four byte accesses.



**Figure 7-4 Access Sizes and Data Alignment Control (8-Bit Access Space)**

**16-Bit Access Space:** Figure 7-5 illustrates data alignment control for the 16-bit access space. With the 16-bit access space, the upper data bus (D15 to D8) and lower data bus (D7 to D0) are used for accesses. The amount of data that can be accessed at one time is one byte or one word, and a longword transfer instruction is executed as two word transfer instructions.

In byte access, whether the upper or lower data bus is used is determined by whether the address is even or odd. The upper data bus is used for an even address, and the lower data bus for an odd address.



**Figure 7-5 Access Sizes and Data Alignment Control (16-Bit Access Space)**



### 7.4.3 Valid Strobes

Table 7-4 shows the data buses used and valid strobes for the access spaces.

In a read, the  $\overline{RD}$  signal is valid without discrimination between the upper and lower halves of the data bus.

In a write, the  $\overline{HWR}$  signal is valid for the upper half of the data bus, and the  $\overline{LWR}$  signal for the lower half.

**Table 7-4 Data Buses Used and Valid Strobes**

Area	Access Size	Read/Write	Address	Valid Strobe	Upper Data Bus (D15 to D8)	Lower data bus (D7 to D0)
8-bit access space	Byte	Read	—	$\overline{RD}$	Valid	Invalid
		Write	—	$\overline{HWR}$		Hi-Z
16-bit access space	Byte	Read	Even	$\overline{RD}$	Valid	Invalid
			Odd		Invalid	Valid
		Write	Even	$\overline{HWR}$	Valid	Hi-Z
			Odd	$\overline{LWR}$	Hi-Z	Valid
	Word	Read	—	$\overline{RD}$	Valid	Valid
		Write	—		$\overline{HWR}, \overline{LWR}$	Valid

Notes: Hi-Z: High impedance.

Invalid: Input state; input value is ignored.

### 7.4.4 Basic Timing

**8-Bit 2-State Access Space:** Figure 7-6 shows the bus timing for an 8-bit 2-state access space. When an 8-bit access space is accessed, the upper half (D15 to D8) of the data bus is used.

The  $\overline{\text{LWR}}$  pin is fixed high. Wait states cannot be inserted.

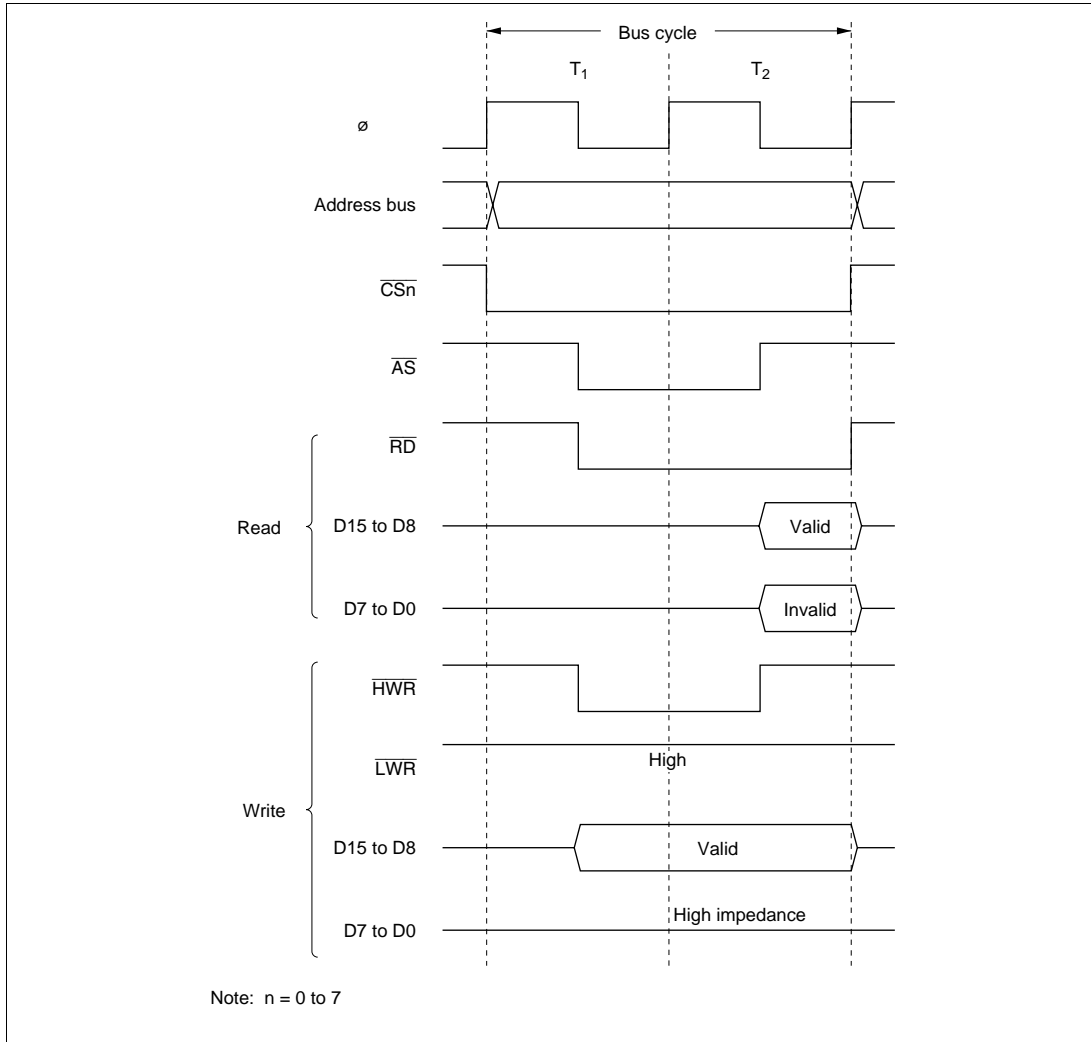
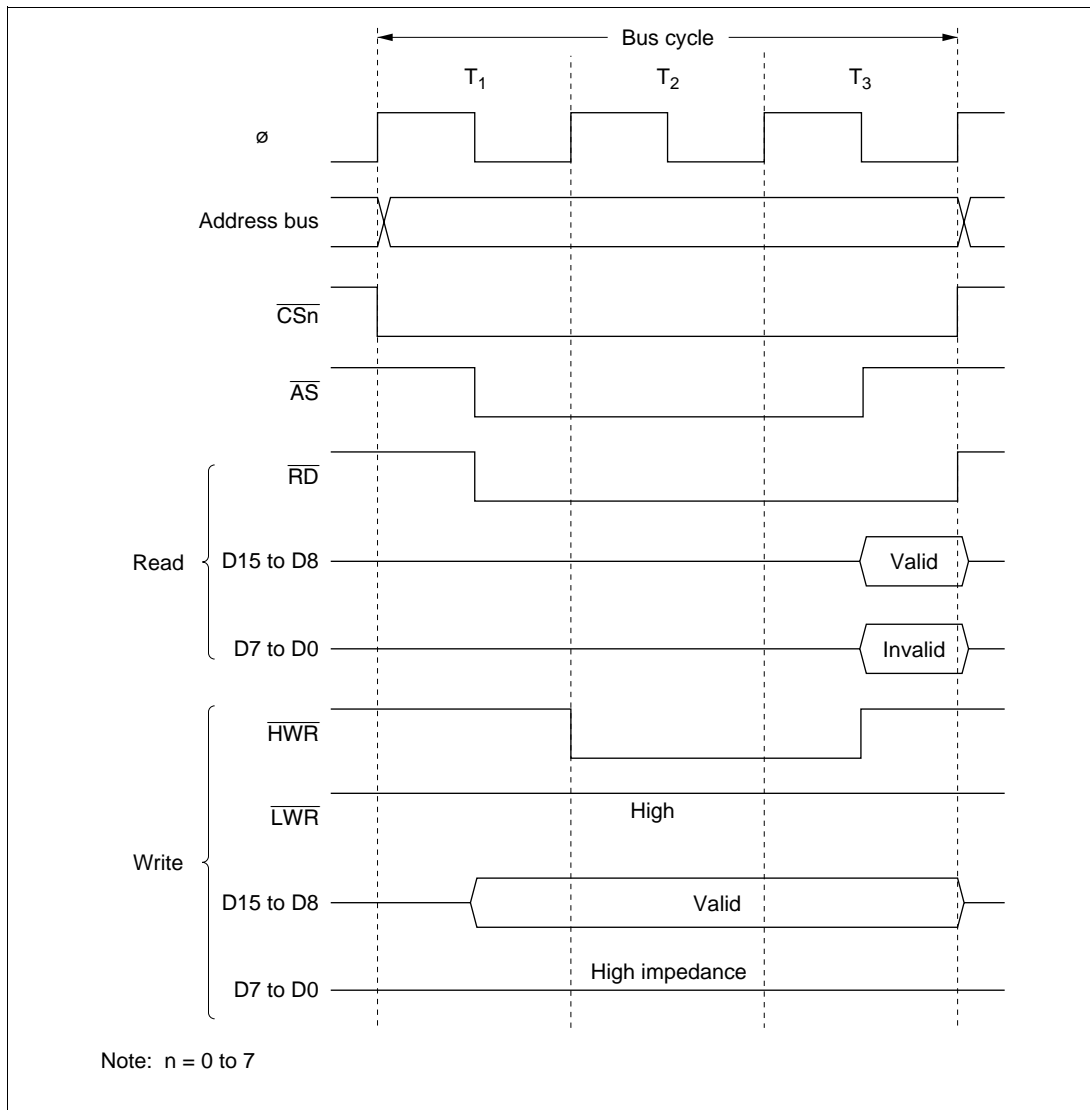


Figure 7-6 Bus Timing for 8-Bit 2-State Access Space

**8-Bit 3-State Access Space:** Figure 7-7 shows the bus timing for an 8-bit 3-state access space. When an 8-bit access space is accessed, the upper half (D15 to D8) of the data bus is used.

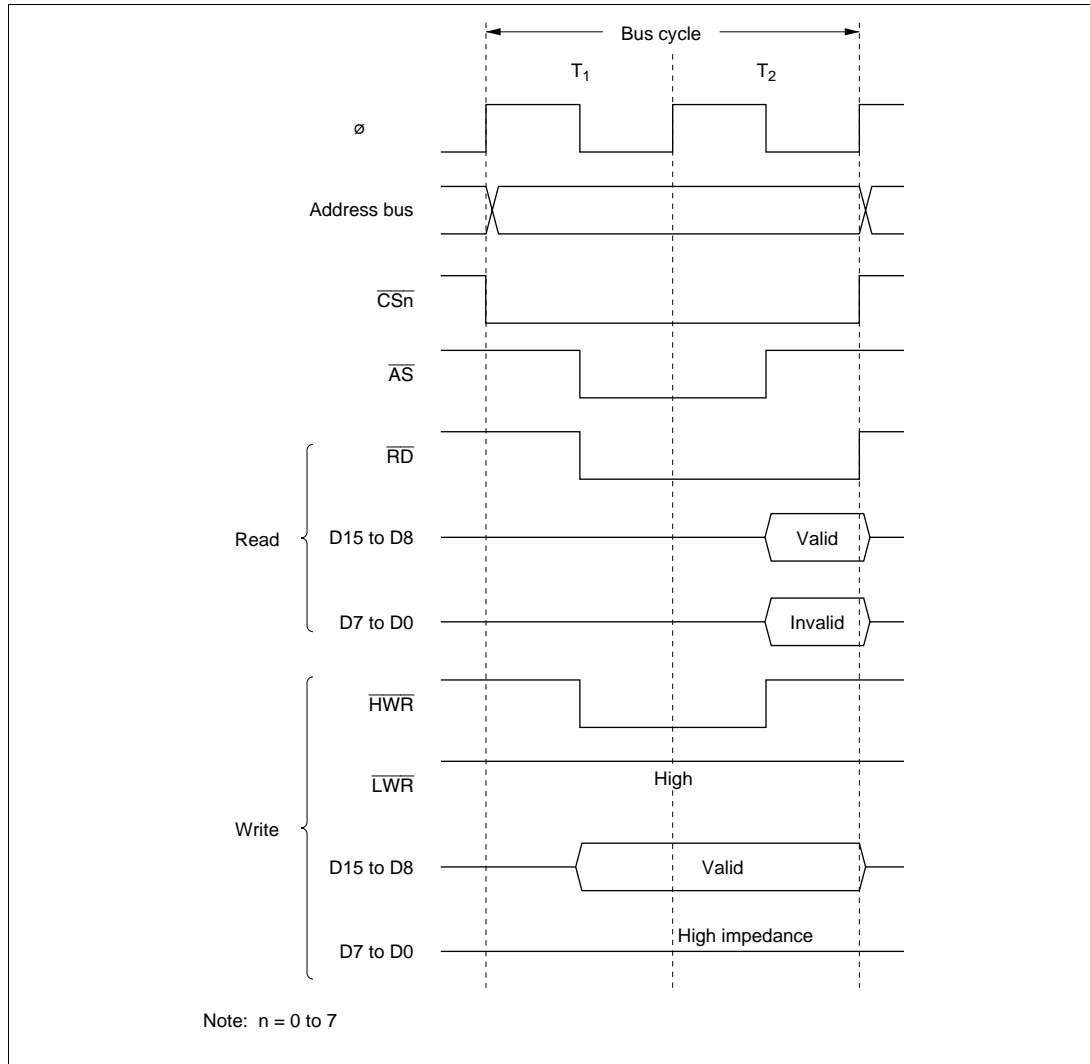
The  $\overline{\text{LWR}}$  pin is fixed high. Wait states can be inserted.



**Figure 7-7 Bus Timing for 8-Bit 3-State Access Space**

**16-Bit 2-State Access Space:** Figures 7-8 to 7-10 show bus timings for a 16-bit 2-state access space. When a 16-bit access space is accessed, the upper half (D15 to D8) of the data bus is used for the even address, and the lower half (D7 to D0) for the odd address.

Wait states cannot be inserted.



**Figure 7-8 Bus Timing for 16-Bit 2-State Access Space (1) (Even Address Byte Access)**

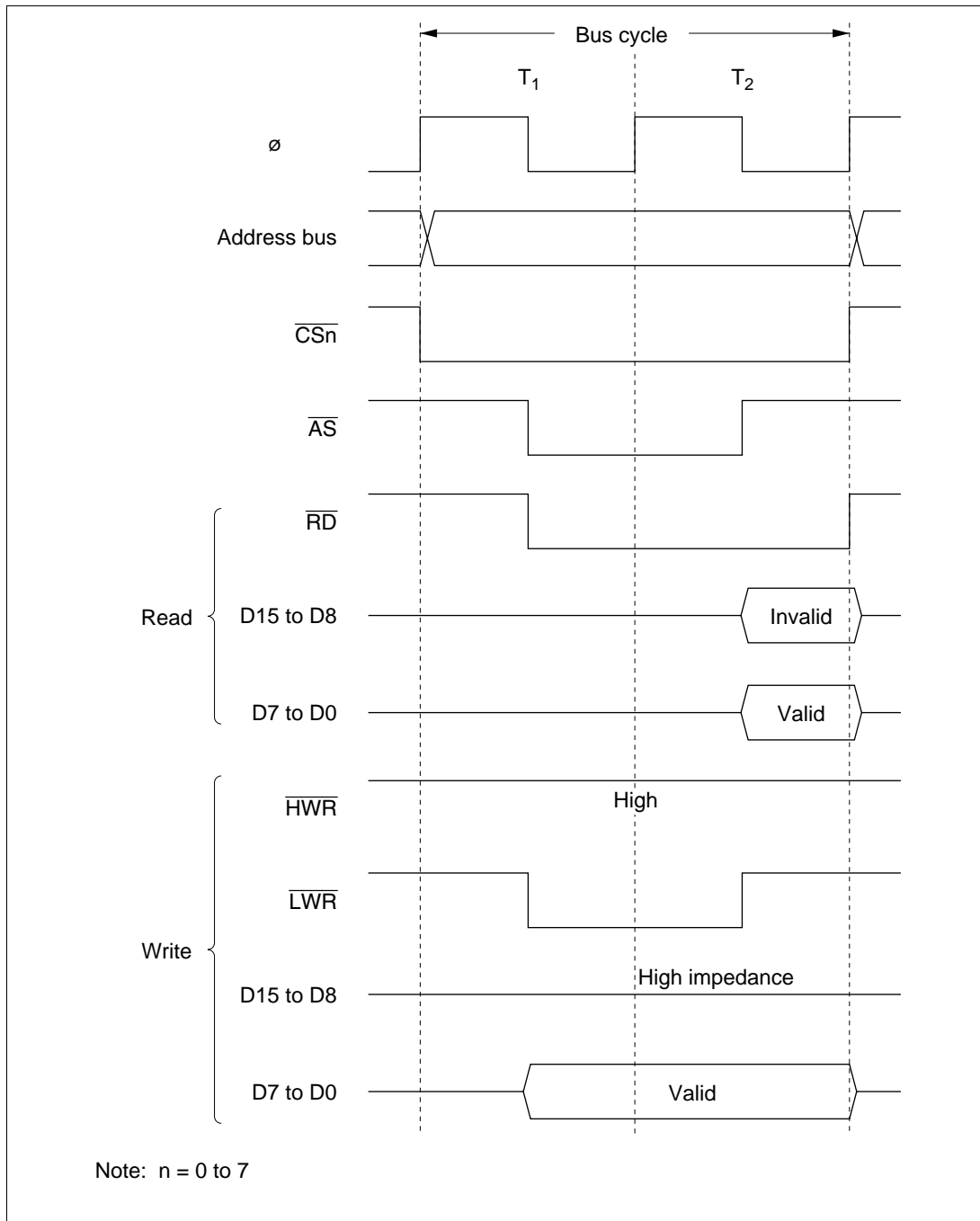
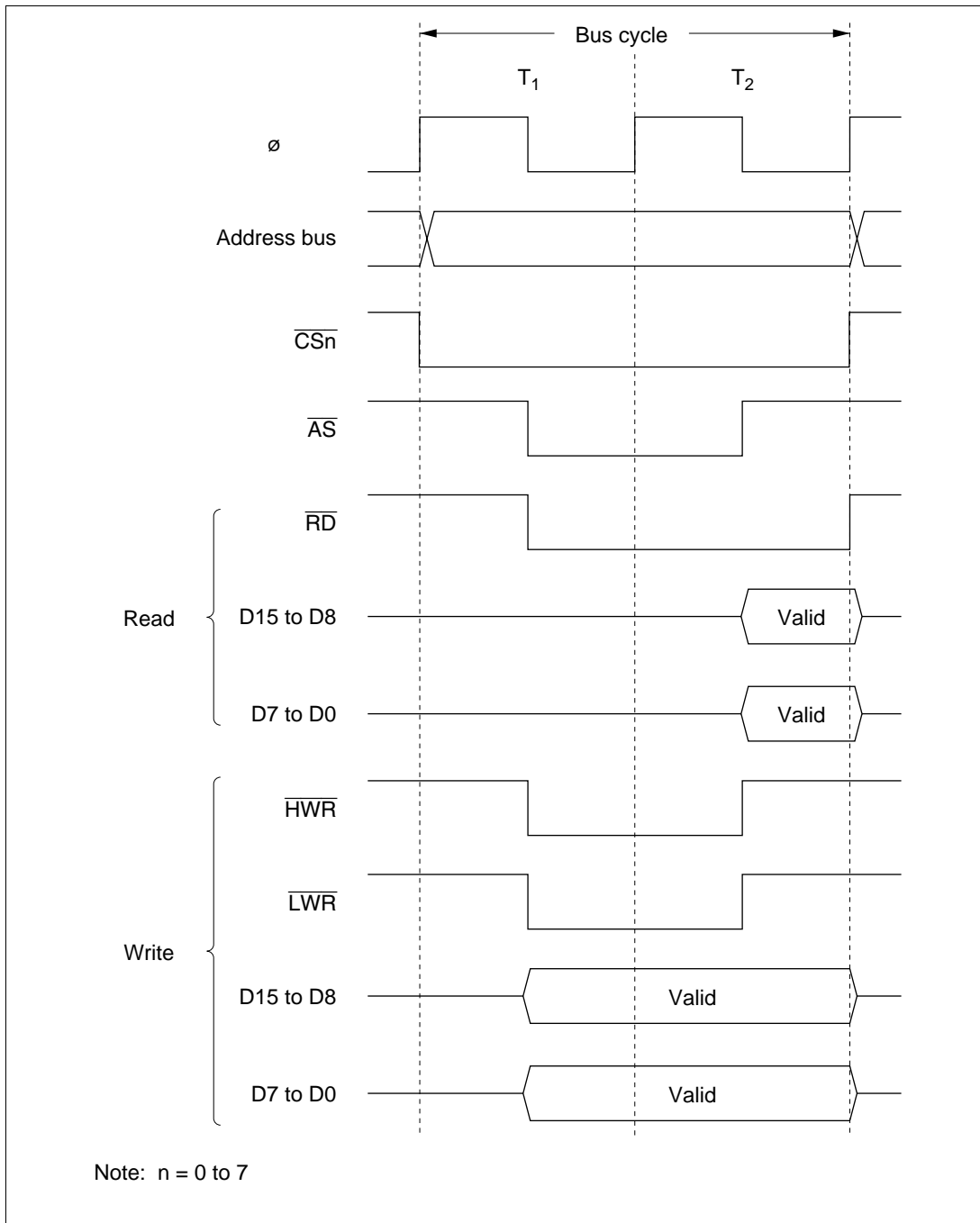


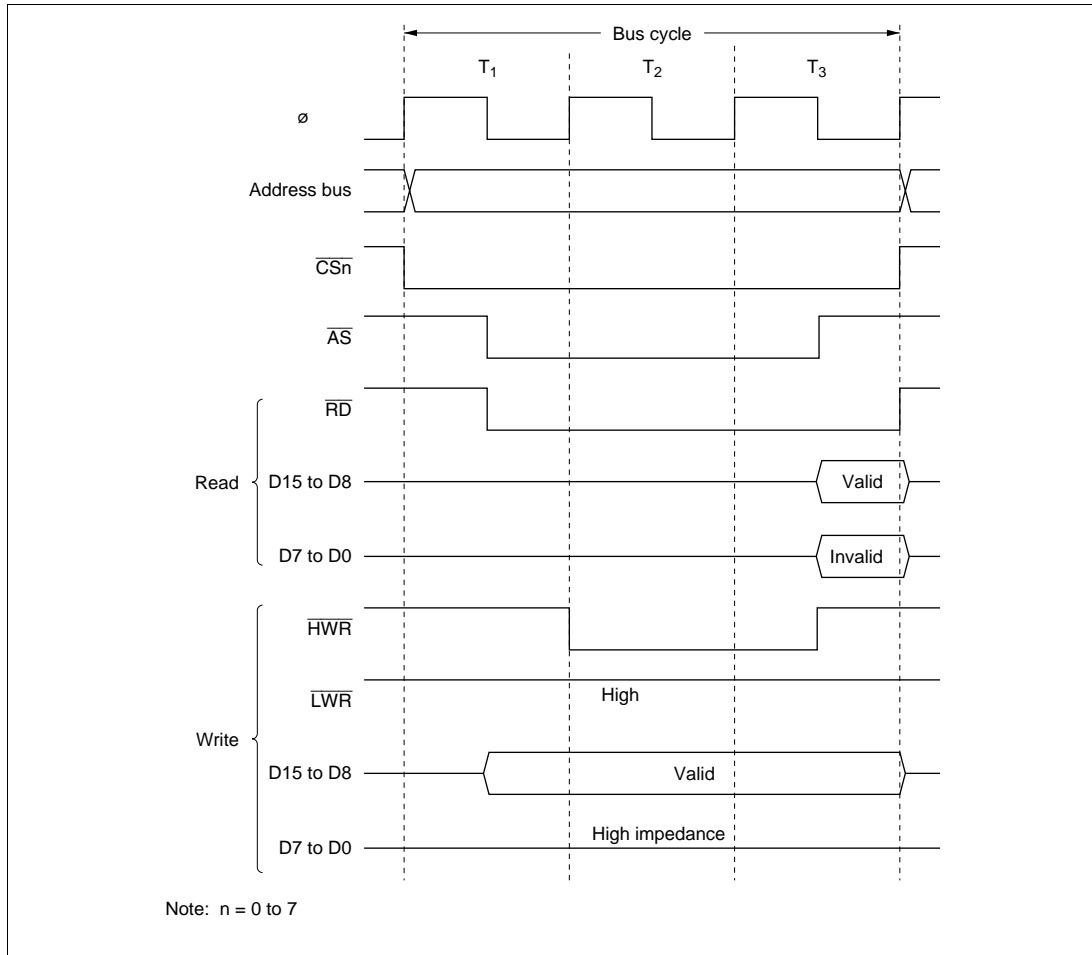
Figure 7-9 Bus Timing for 16-Bit 2-State Access Space (2) (Odd Address Byte Access)



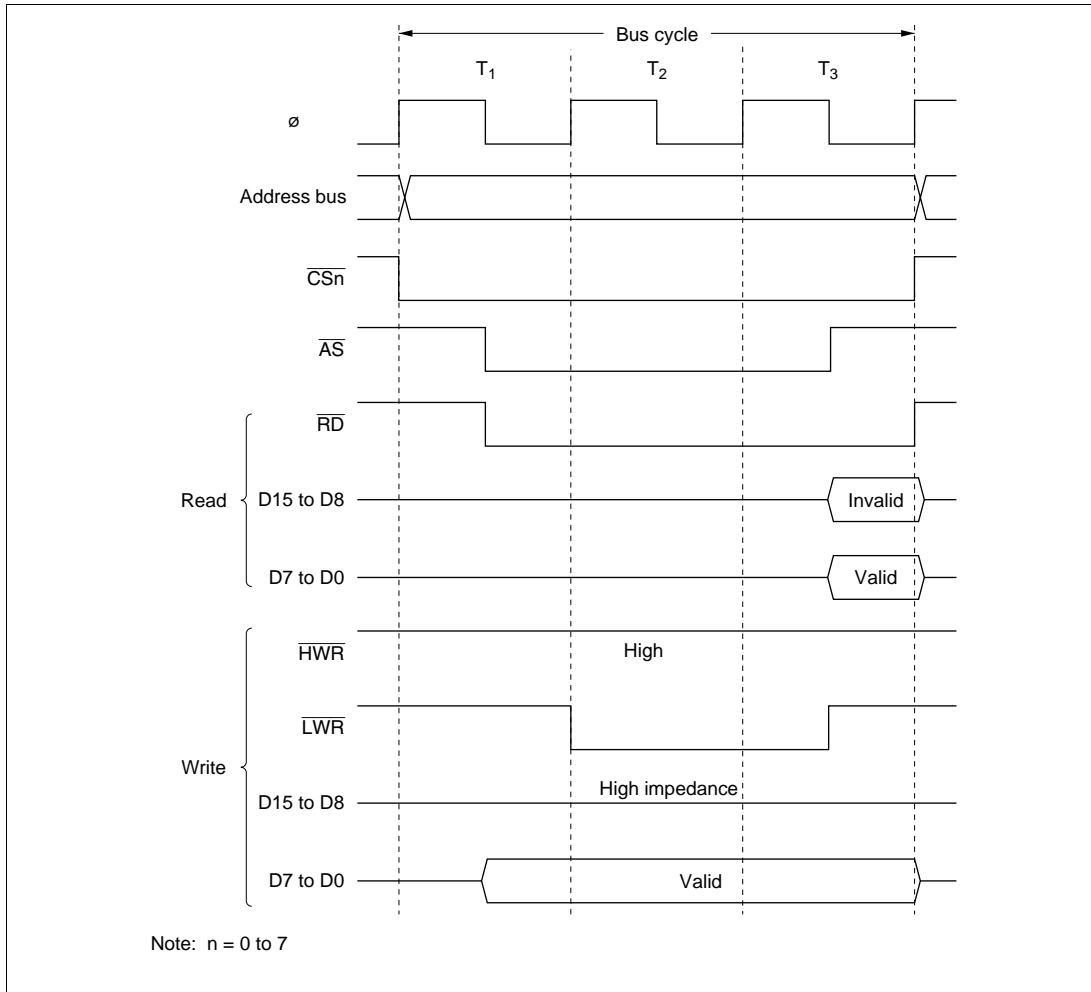
**Figure 7-10 Bus Timing for 16-Bit 2-State Access Space (3) (Word Access)**

**16-Bit 3-State Access Space:** Figures 7-11 to 7-13 show bus timings for a 16-bit 3-state access space. When a 16-bit access space is accessed, the upper half (D15 to D8) of the data bus is used for the even address, and the lower half (D7 to D0) for the odd address.

Wait states can be inserted.



**Figure 7-11 Bus Timing for 16-Bit 3-State Access Space (1) (Even Address Byte Access)**



**Figure 7-12 Bus Timing for 16-Bit 3-State Access Space (2) (Odd Address Byte Access)**



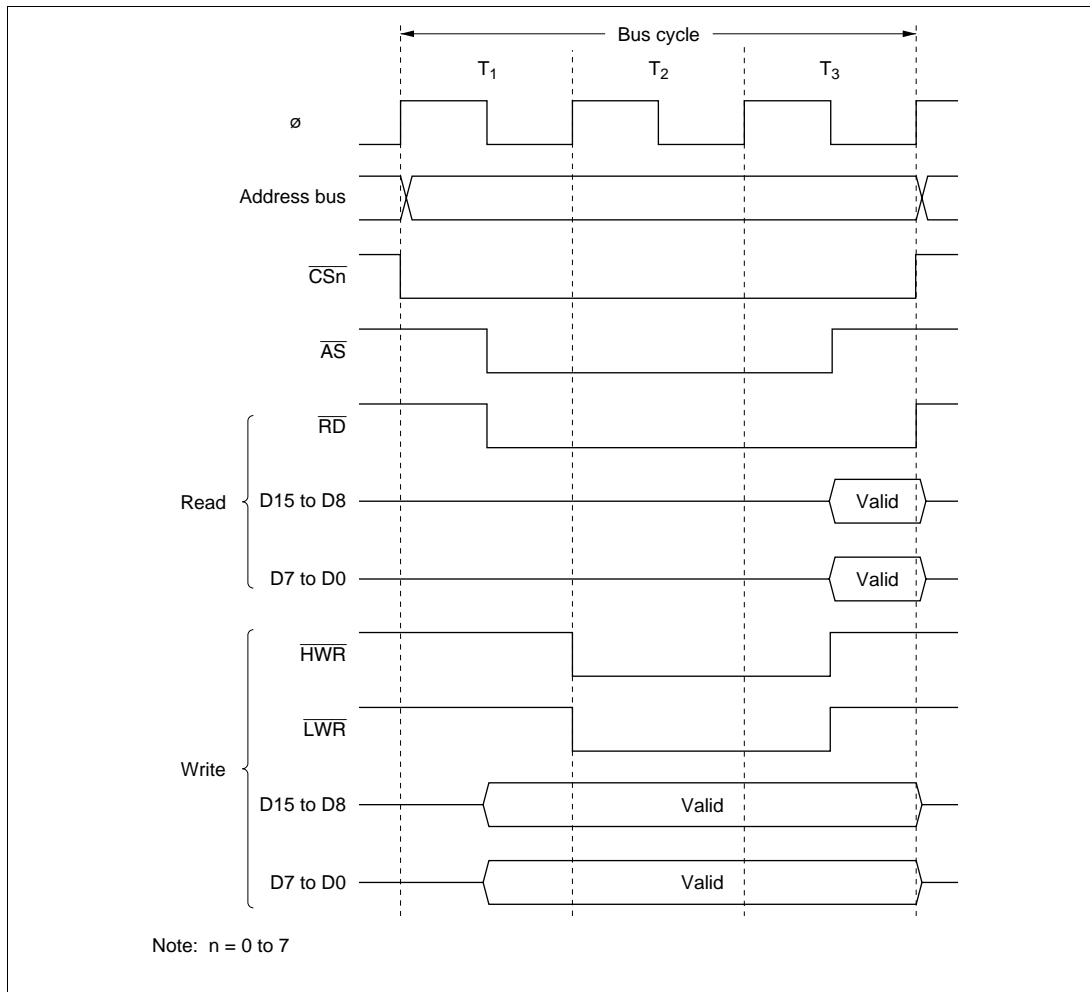


Figure 7-13 Bus Timing for 16-Bit 3-State Access Space (3) (Word Access)

#### 7.4.5 Wait Control

When accessing external space, the H8S/2633 Series can extend the bus cycle by inserting one or more wait states ( $T_w$ ). There are two ways of inserting wait states: program wait insertion and pin wait insertion using the  $\overline{\text{WAIT}}$  pin.

##### Program Wait Insertion

From 0 to 3 wait states can be inserted automatically between the  $T_2$  state and  $T_3$  state on an individual area basis in 3-state access space, according to the settings of WCRH and WCRL.

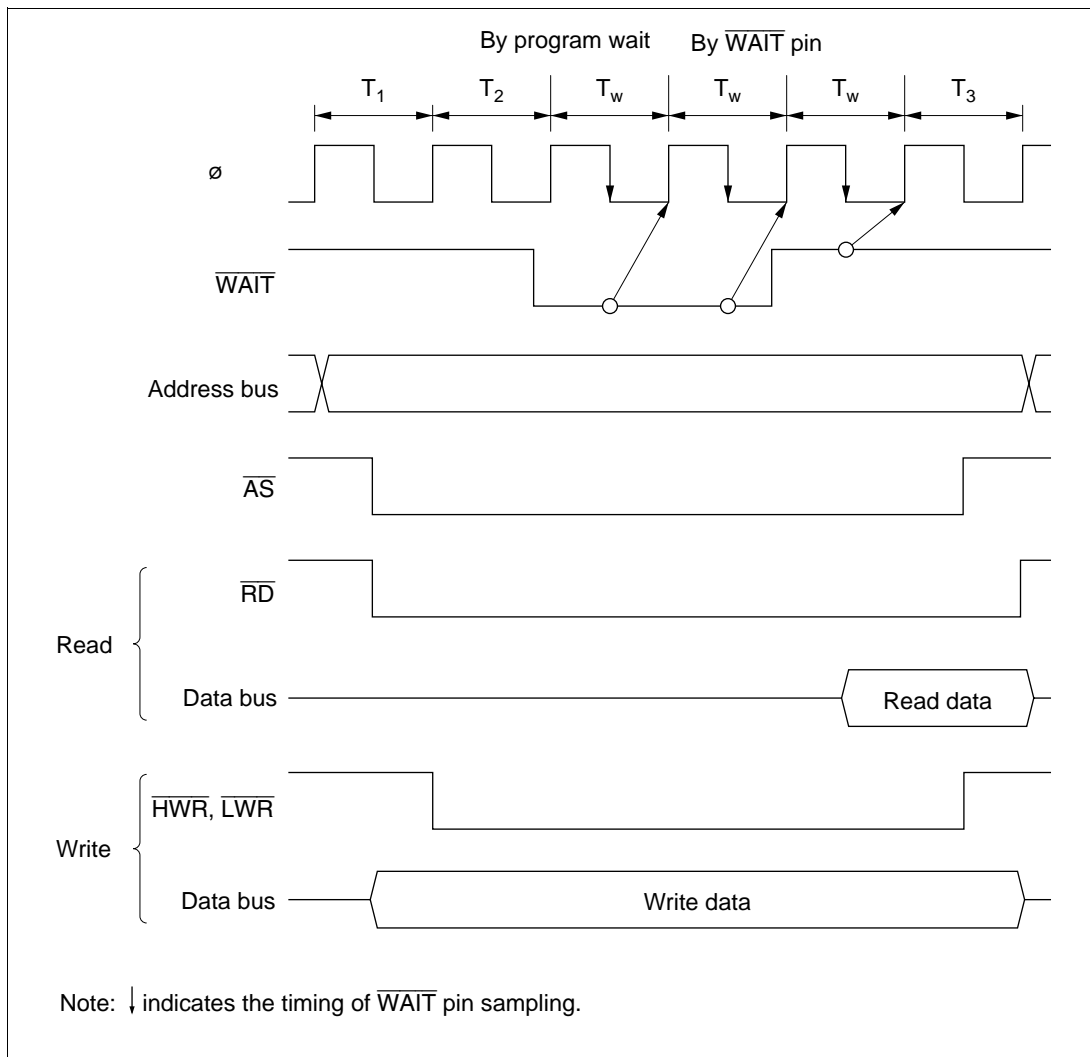
##### Pin Wait Insertion

Setting the WAITE bit in BCRL to 1 enables wait insertion by means of the  $\overline{\text{WAIT}}$  pin. Program wait insertion is first carried out according to the settings in WCRH and WCRL. Then, if the  $\overline{\text{WAIT}}$  pin is low at the falling edge of  $\phi$  in the last  $T_2$  or  $T_w$  state, a  $T_w$  state is inserted. If the  $\overline{\text{WAIT}}$  pin is held low,  $T_w$  states are inserted until it goes high.

This is useful when inserting four or more  $T_w$  states, or when changing the number of  $T_w$  states for different external devices.

The WAITE bit setting applies to all areas.

Figure 7-14 shows an example of wait state insertion timing.



**Figure 7-14 Example of Wait State Insertion Timing**

The settings after a power-on reset are: 3-state access, 3 program wait state insertion, and  $\overline{\text{WAIT}}$  input disabled. At a manual reset, the bus control register values are retained and wait control continues as before the reset.

## 7.5 DRAM Interface (This function is not available in the H8S/2695)

### 7.5.1 Overview

This LSI allows area 2 to 5 external space to be set as DRAM space and DRAM interfacing to be performed. With the DRAM interface, DRAM can be directly connected to the LSI. BCRH RMTS2 to RMTS0 allow the setting up of 2, 4, or 8MB DRAM space. Burst operation is possible using high-speed page mode.

### 7.5.2 Setting up DRAM Space

To set up areas 2 to 5 as DRAM space, set the RMTS2 to RMTS0 bits of BCRH. Table 7-5 shows the relationship between the settings of the RMTS2 to RMTS0 bits and DRAM space. You can select (1) one area (area 2), (2) two areas (areas 2 and 3), or (3) four areas (areas 2 to 5).

Using 16 64M DRAMs requires a 4M word (8MB) contiguous space. Setting RMTS2 to RMTS0 to 1 allows areas 2 to 5 to be configured as one contiguous DRAM space. The RAS signal can be output from the  $\overline{CS2}$  pin, and  $\overline{CS3}$  to  $\overline{CS5}$  can be used as input ports. In this configuration, the bus widths are the same for areas 2 to 5.

**Table 7-5 RMTS2 to RMTS0 Settings vs DRAM Space**

RMTS2	RMTS1	RMTS0	Area 5	Area 4	Area 3	Area 2
0	0	1	Normal space	Normal space	Normal space	DRAM space
		0	Normal space	Normal space	DRAM space	DRAM space
		1	DRAM space	DRAM space	DRAM space	DRAM space
1	1	1	Contiguous DRAM space	Contiguous DRAM space	Contiguous DRAM space	Contiguous DRAM space

### 7.5.3 Address Multiplexing

In the case of DRAM space, the row address and column address are multiplexed. With address multiplexing, the MXC1 and MXC0 bits of the MCR select the amount of shift in the row address. Table 7-6 shows the relationship between MXC1 and MXC0 settings and the shift amount.

**Table 7-6 MXC1 and MXC0 Settings vs Address Multiplexing**

	MCR		Shift Amount	Address Pin													
	MXC1	MXC0		A23 to A13	A12	A11	A10	A9	A8	A7	A6	A5	A4	A3	A2	A1	A0
Row address	0	0	8 bits	A23 to A13	A20	A19	A18	A17	A16	A15	A14	A13	A12	A11	A10	A9	A8
		1	9 bits	A23 to A13	A12	A20	A19	A18	A17	A16	A15	A14	A13	A12	A11	A10	A9
	1	0	10 bits	A23 to A13	A12	A11	A20	A19	A18	A17	A16	A15	A14	A13	A12	A11	A10
		1	Do not set	—	—	—	—	—	—	—	—	—	—	—	—	—	—
Column address	—	—	—	A23 to A13	A12	A11	A10	A9	A8	A7	A6	A5	A4	A3	A2	A1	A0

### 7.5.4 Data Bus

Setting the ABWCR bit of an area set as DRAM space to 1 sets the corresponding area as 8-bit DRAM space. Clearing the ABWCR bit to 0 sets the area as 16-bit DRAM. 16-bit DRAMs can be directly connected in the case of 16-bit DRAM space.

With 8-bit DRAM space, the high data bus byte (D15 to D8) is valid. With 16-bit DRAM space, the high and low data bus bytes (D15 to D0) are valid.

The access size and data alignment are the same as for the standard bus interface. See section 7.4.2, Data Size and Data Alignment for details.

### 7.5.5 DRAM Interface Pins

Table 7-7 shows the pins used for the DRAM interface, and their functions.

**Table 7-7 DRAM Interface Pin Configuration**

Pin	In DRAM Mode	Name	Direction	Function
$\overline{\text{HWR}}$	$\overline{\text{WE}}$	Write enable	Output	Write enable when accessing DRAM space in 2 CAS mode
$\overline{\text{LCAS}}$	$\overline{\text{LCAS}}$	Lower column address strobe	Output	Lower column address strobe signal when accessing 16-bit DRAM space
$\overline{\text{CS2}}$	$\overline{\text{RAS2}}$	Row address strobe 2	Output	Row address strobe when area 2 set as DRAM space
$\overline{\text{CS3}}$	$\overline{\text{RAS3}}$	Row address strobe 3	Output	Row address strobe when area 3 set as DRAM space
$\overline{\text{CS4}}$	$\overline{\text{RAS4}}$	Row address strobe 4	Output	Row address strobe when area 4 set as DRAM space
$\overline{\text{CS5}}$	$\overline{\text{RAS5}}$	Row address strobe 5	Output	Row address strobe when area 5 set as DRAM space
$\overline{\text{CAS}}$	$\overline{\text{UCAS}}$	Upper column address strobe	Output	Upper column address strobe when accessing DRAM space
$\overline{\text{WAIT}}$	$\overline{\text{WAIT}}$	Wait	Input	Wait request signal
A12 to A0	A12 to A0	Address pin	Output	Multiplexed output of row address and column address
D15 to D0	D15 to D0	Data pin	Input/output	Data input/output pin
$\overline{\text{OE}}$	$\overline{\text{OE}}^*$	Output enable pin	Output	Output enable signal when accessing DRAM space in read mode

Note: \* Valid when OES bit set to 1.

### 7.5.6 Basic Timing

Figure 7-15 shows the basic access timing for DRAM space. There are four basic DRAM timing states. In contrast to the standard bus interface, the corresponding ASTCR bit only controls the enabling/disabling of wait insertion and has no effect on the number of access states. When the corresponding ASTCR bit is cleared to 0, no wait states can be inserted in the DRAM access cycle.

The four basic timing states are as follows:  $T_p$  (precharge cycle) 1 state,  $T_r$  (row address output cycle) 1 state,  $T_{c1}$  and  $T_{c2}$  (column address output cycle) two states.

When RCTS is set to 1, the  $\overline{\text{CAS}}$  signal timing differs when reading and writing, being asserted  $\Omega$  cycle earlier when reading.

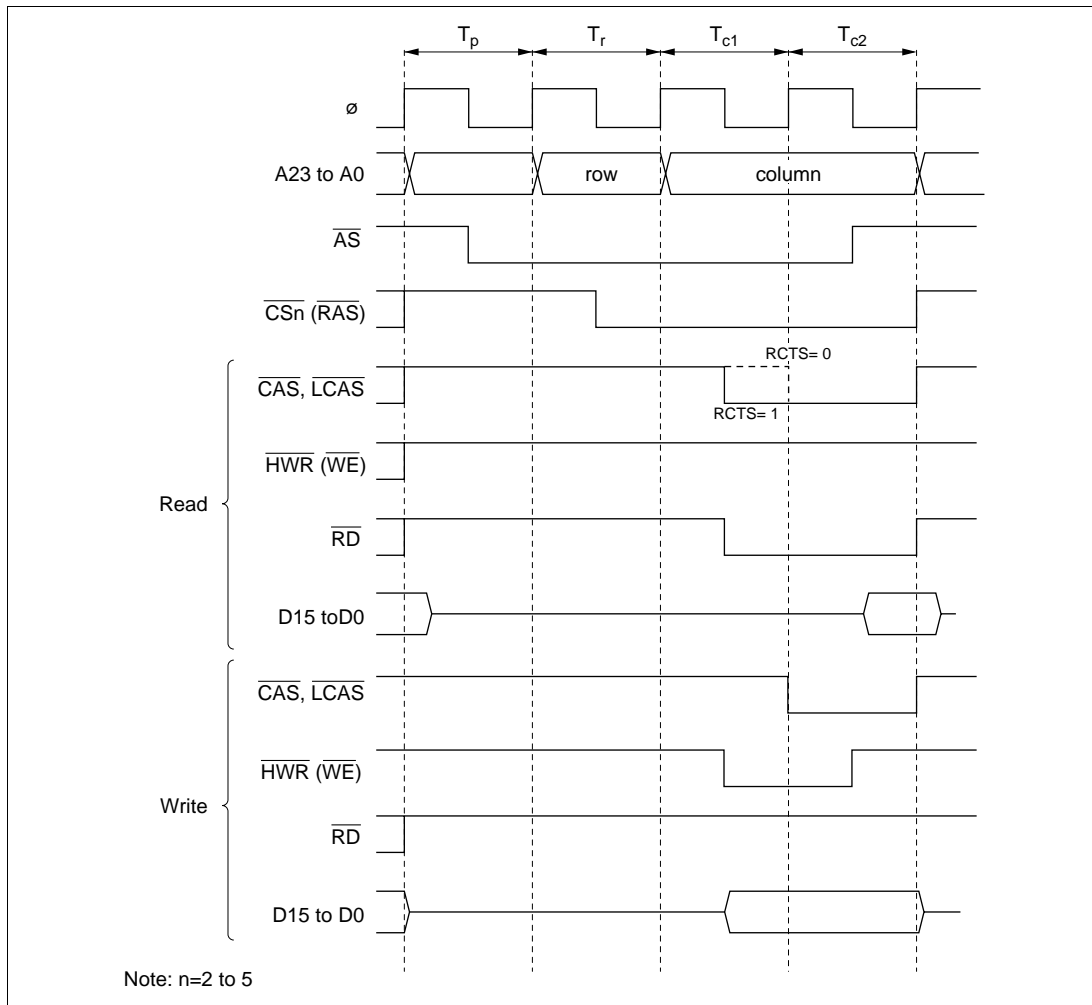


Figure 7-15 Basic Access Timing

### 7.5.7 Precharge State Control

When accessing DRAM, it is essential to secure a time for RAS precharging. In this LSI, it is therefore necessary to insert 1  $T_p$  state when accessing DRAM space. By setting the TPC bit of the MCR to 1,  $T_p$  can be changed from 1 state to 2 states. Set the appropriate number of  $T_p$  cycles according to the type of DRAM connected and the operation frequency of the LSI. Figure 7-16 shows the timing when  $T_p$  is set for 2 states.

Setting the TPC bit to 1 also sets the refresh cycle  $T_p$  to 2 states.

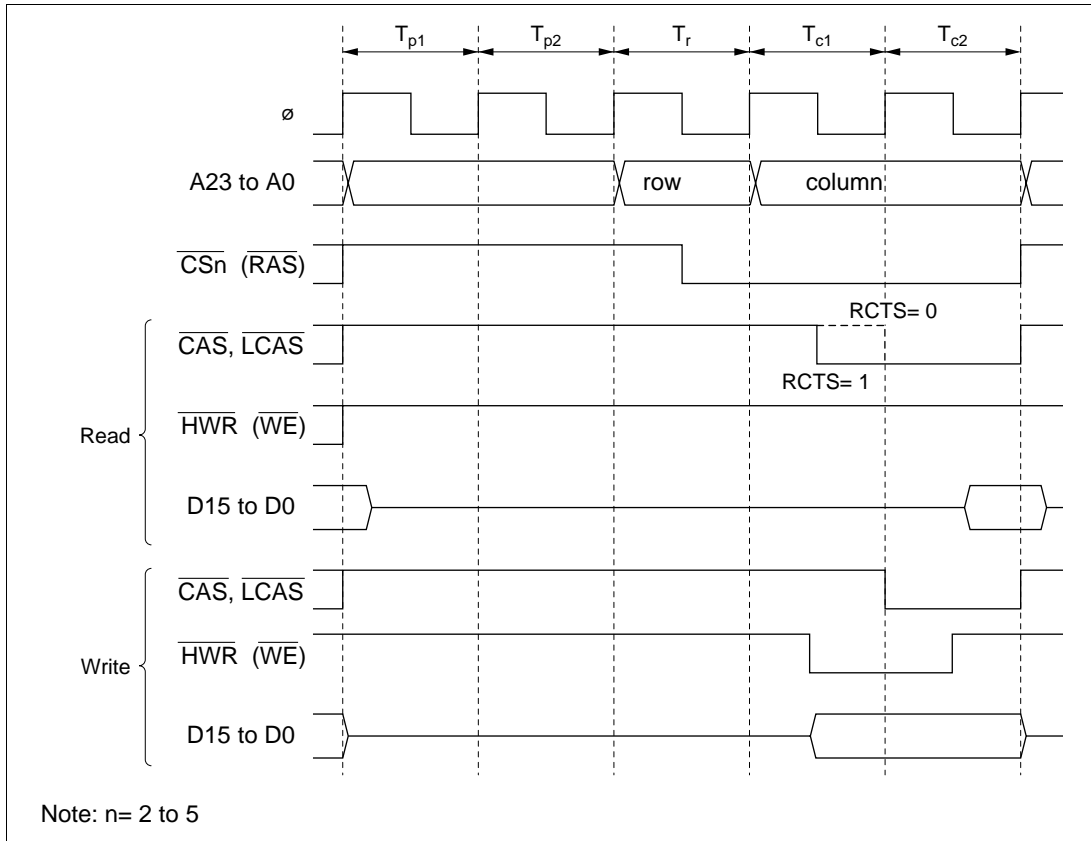


Figure 7-16 Timing With Two Precharge Cycles



### 7.5.8 Wait Control

There are two methods of inserting wait states in DRAM access: (1) insertion of program wait states, and (2) insertion of pin waits via  $\overline{\text{WAIT}}$  pin.

#### (1) Insertion of Program Wait States

Setting the ASTCR bit of an area set for DRAM to 1 automatically inserts from 0 to 3 wait states, as set by WCRH and WCRL, between the  $T_{c1}$  state and  $T_{c2}$  state.

When a program wait is inserted, the write wait function is activated and only the  $\overline{\text{CAS}}$  signal is output only during the  $T_{c2}$  state when writing.

Figure 7-17 shows example timing for the insertion of program waits.

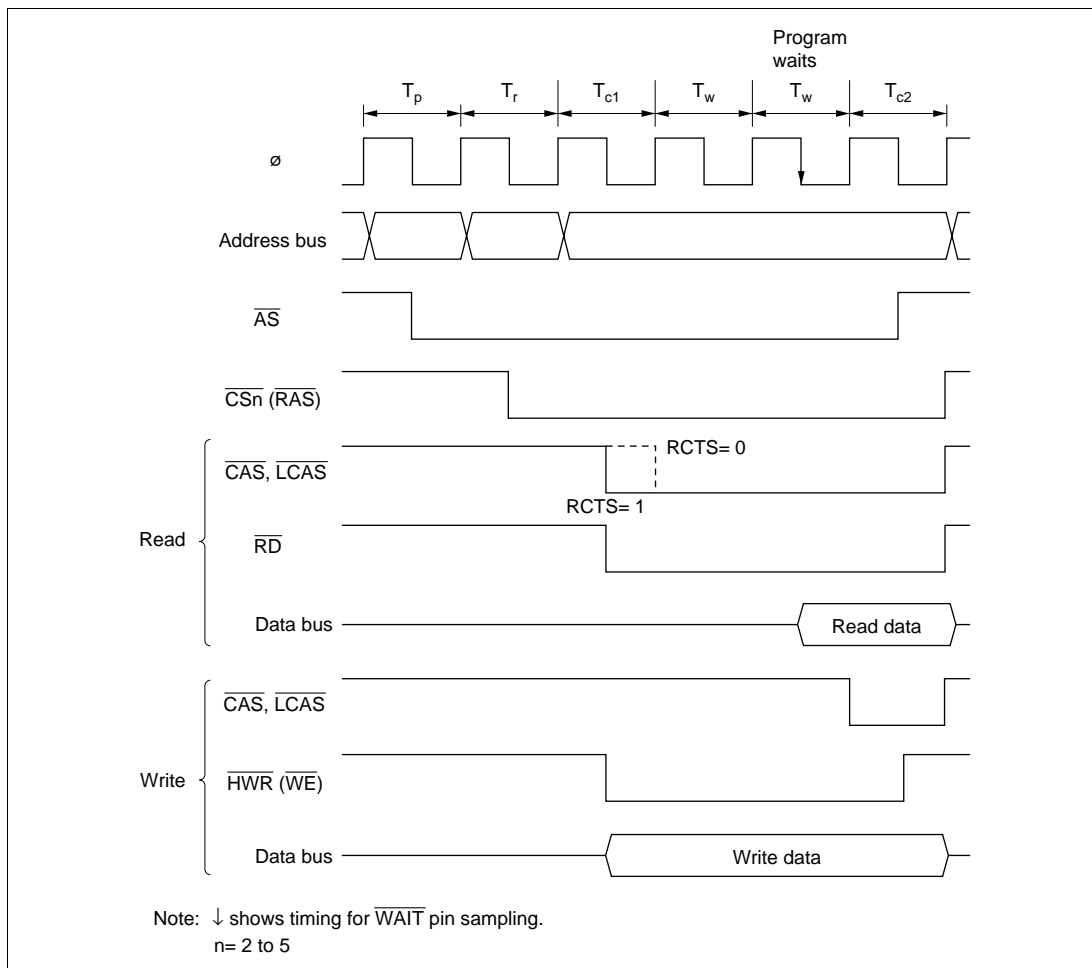


Figure 7-17 Example Program Wait Insertion Timing (Wait 2 State Insertion)

## (2) Insertion of Pin Waits

When the WAITE bit of BCRH is set to 1, wait input via the  $\overline{\text{WAIT}}$  pin is valid regardless of the ASTCR AST bit. In this state, a program wait is inserted when the DRAM space is accessed. If the  $\overline{\text{WAIT}}$  pin level is Low at the fall in  $\phi$  in the final  $T_{c1}$  or  $T_w$  state, a further  $T_w$  is inserted. If the level of the  $\overline{\text{WAIT}}$  pin is kept Low,  $T_w$  is inserted until the level of the  $\overline{\text{WAIT}}$  pin changes to High.

When wait states are inserted via the  $\overline{\text{WAIT}}$  pin, the  $\overline{\text{CAS}}$  when writing is output after the  $T_w$  state.

Figure 7-18 shows example timing for the insertion of wait states via the  $\overline{\text{WAIT}}$  pin.

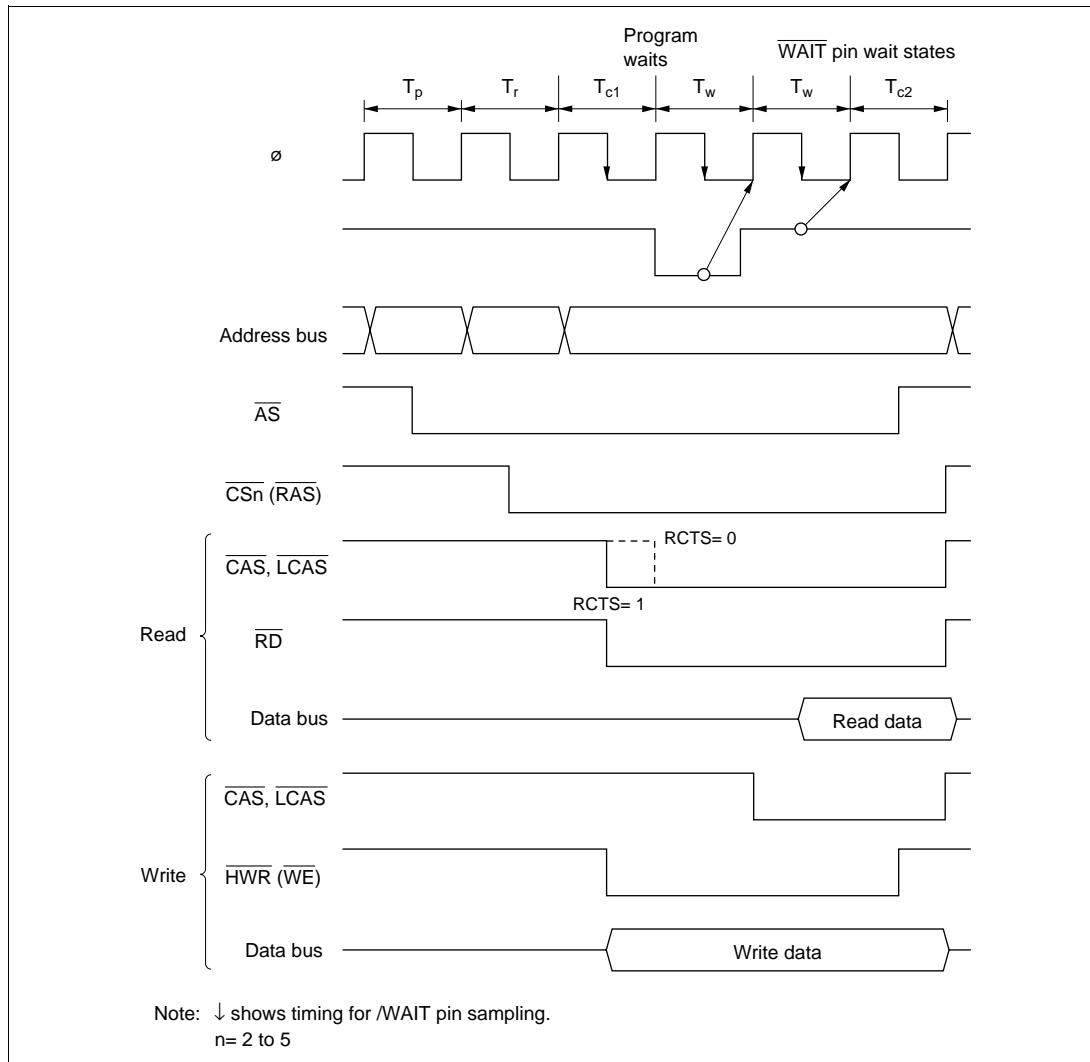


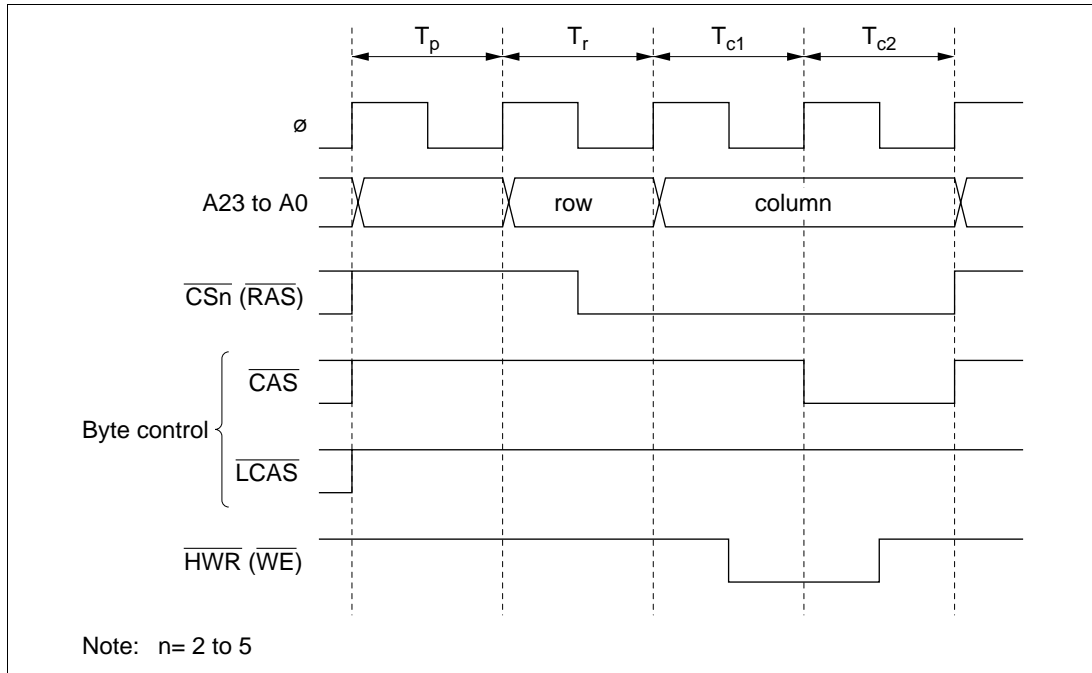
Figure 7-18 Example Timing for Insertion of Wait States via  $\overline{\text{WAIT}}$  Pin

### 7.5.9 Byte Access Control

When 16-bit DRAMs are connected, the 2 CAS method can be used as the control signal required for byte access.

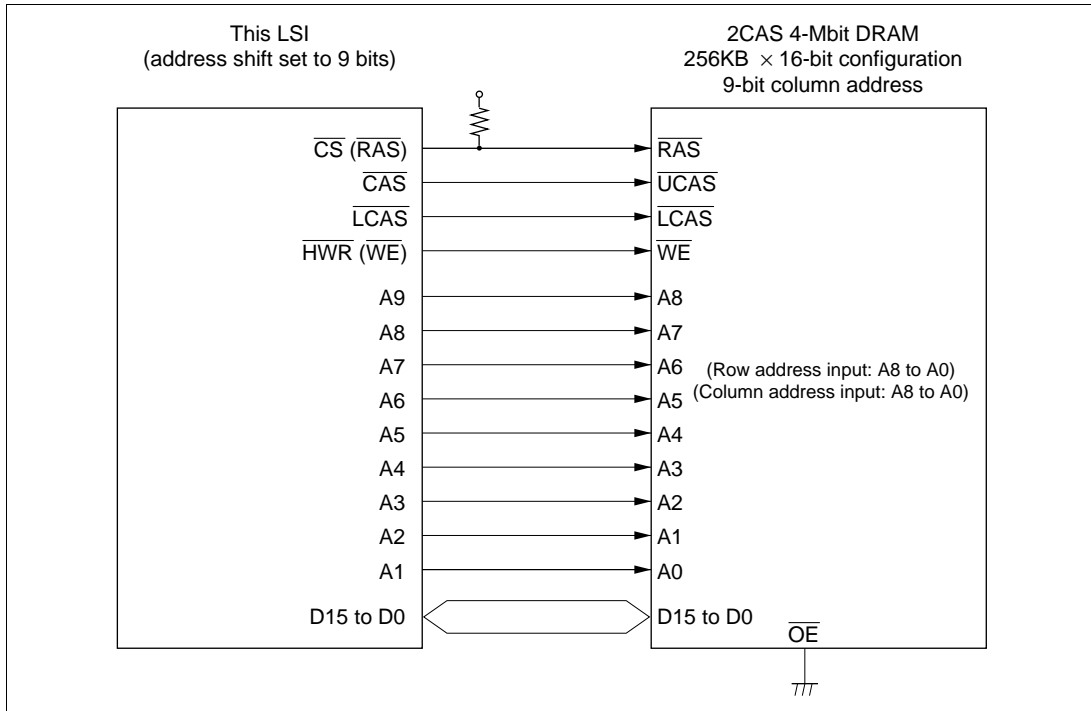
Figure 7-19 shows the 2 CAS method control timing. Figure 7-20 shows an example of connecting DRAM in high-speed page mode.

When all areas selected as DRAM space are set as 8-bit space, the  $\overline{\text{LCAS}}$  pin functions as an I/O port.

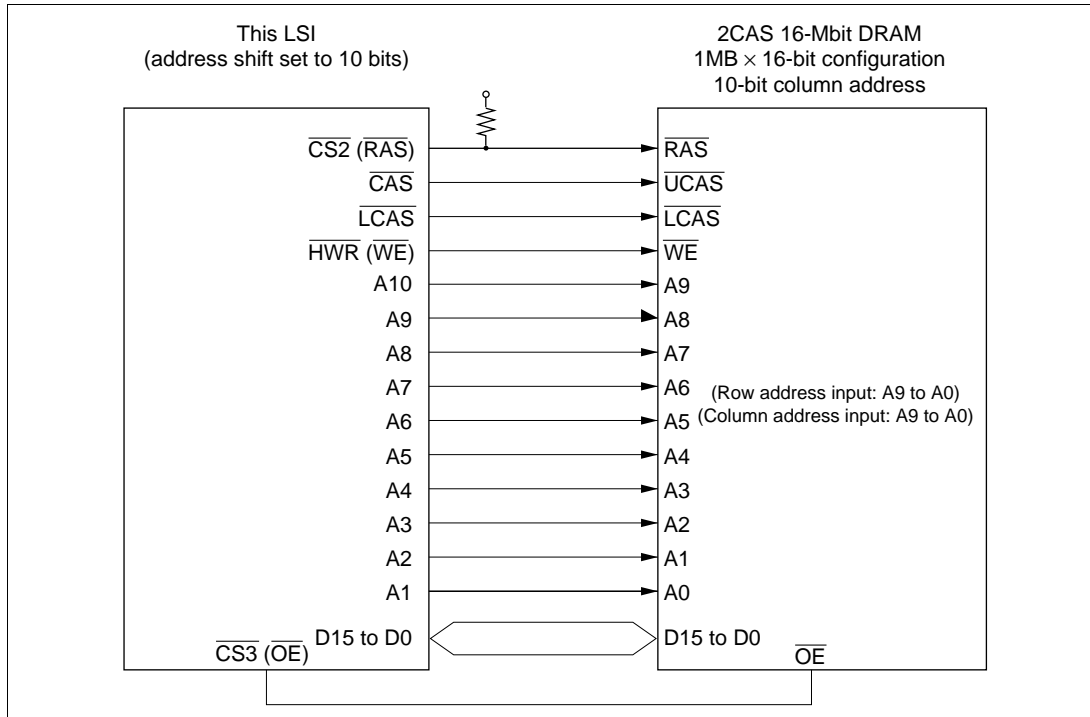


**Figure 7-19 2 CAS Method Control Timing (For High Byte Write Access)**

When using DRAM EDO page mode, either use  $\overline{\text{OE}}$  to control the read data or, as shown in figure 7-20, select RAS up mode. Figure 7-21 is an example of DRAM connection in EDO page mode when OES=1.



**Figure 7-20 High-speed Page Mode DRAM**



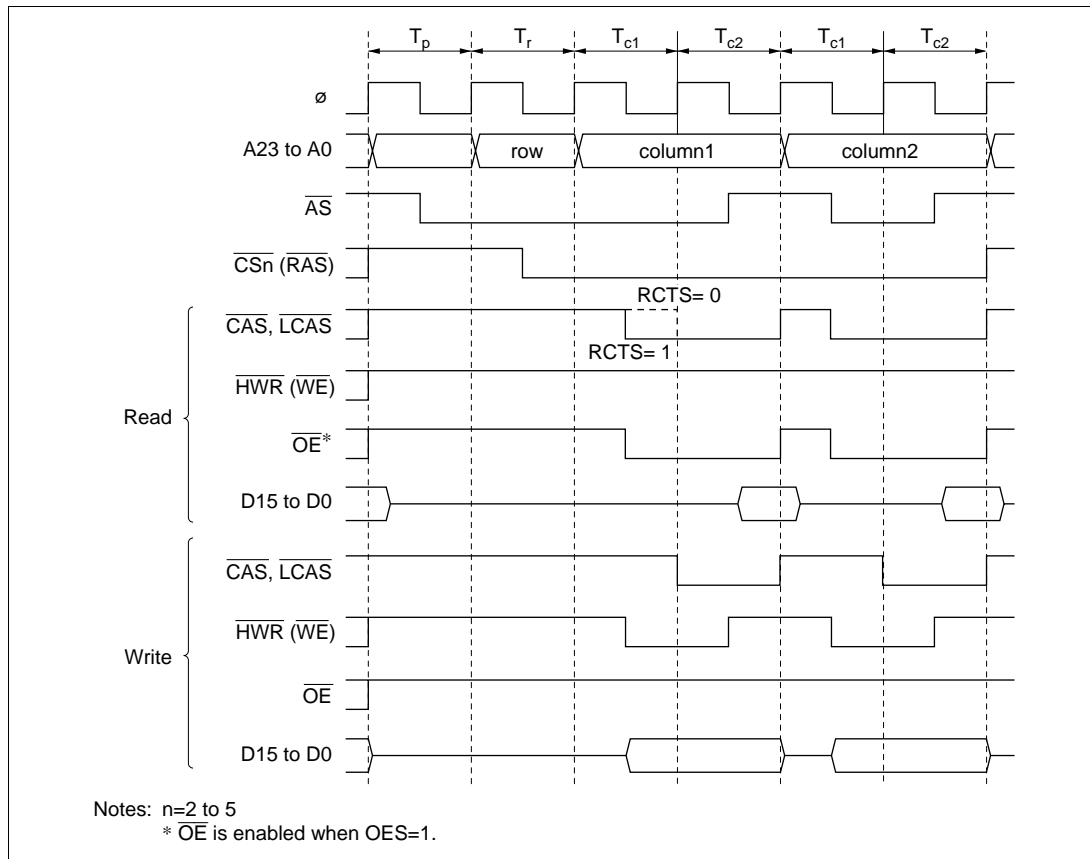
**Figure 7-21 Example Connection of EDO Page Mode DRAM (OES=1)**

### 7.5.10 Burst Operation

In addition to full DRAM access (normal DRAM access), in which the row address is output each time the data in DRAM is accessed, there is also a high-speed page mode that allows high-speed access (burst access). In this method, if the same row address is accessed successively, the row address is output once and then only the column address is changed. Burst access is selected by setting the BE bit of the MCR to 1.

**(1) Operation Timing for Burst Access (High-Speed Page Mode)**

Figure 7-22 shows the operation timing for burst access. When the DRAM space is successively accessed, the  $\overline{\text{CAS}}$  signal and column address output cycle (2 states) are continued as long as the row address is the same in the preceding and succeeding access cycles. The MXC1 and MXC0 bits of the MCR specify which row address is compared.



**Figure 7-22 Operating Timing in High-Speed Page Mode**

The bus cycle can also be extended in burst access by inserting wait states. The method and timing of inserting the wait states is the same as in full access. For details, see section 7.5.8, Wait Control.

## (2) RAS Down Mode and RAS Up Mode

Even when burst operation is selected, DRAM access may not be continuous, but may be interrupted by accessing another area. In this case, burst operation can be continued by keeping the  $\overline{\text{RAS}}$  signal level Low while the other area is accessed and then accessing the same row address in the DRAM space.

- RAS down mode

To select RAS down mode, set the RCDM bit of the MCR to 1. When DRAM access is interrupted and another area accessed, the  $\overline{\text{RAS}}$  signal level is kept Low and, if the row address is the same as previously when the DRAM space is again accessed, burst access is continued. Figure 7-23 shows example RAS down mode timing.

Note that if the refresh operation occurs when RAS is down, the  $\overline{\text{RAS}}$  signal level changes to High.

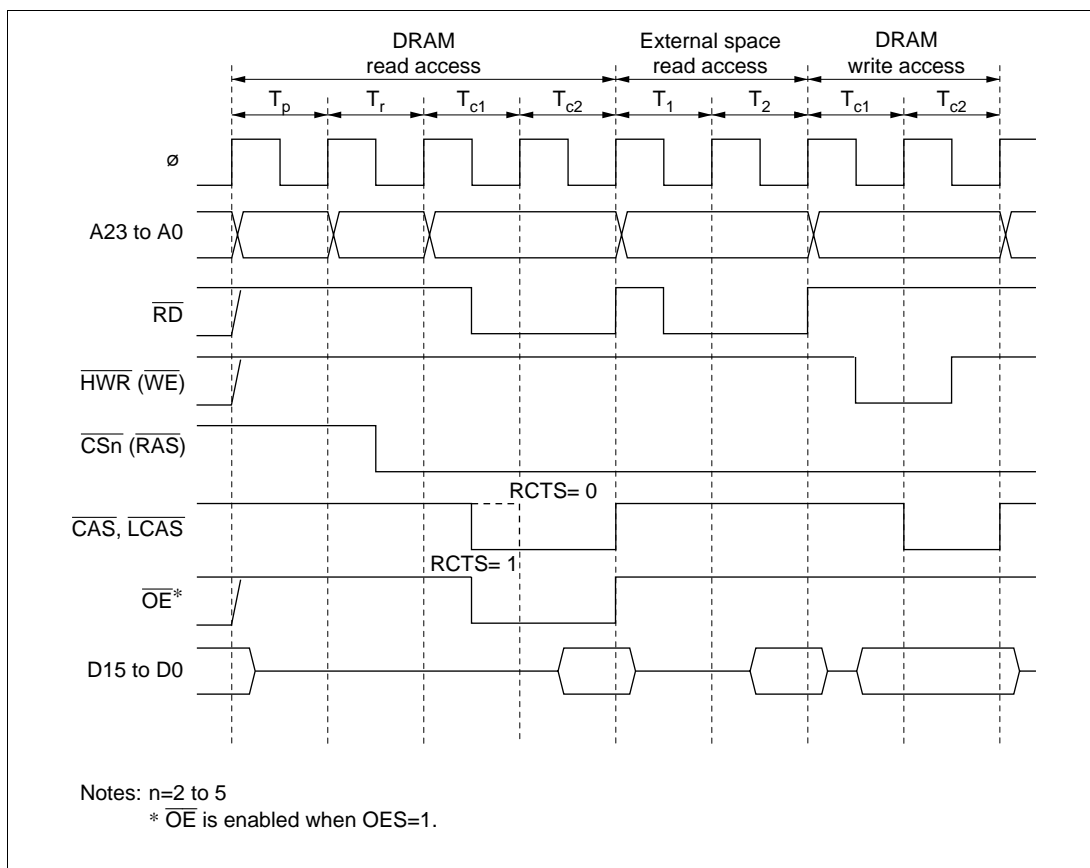
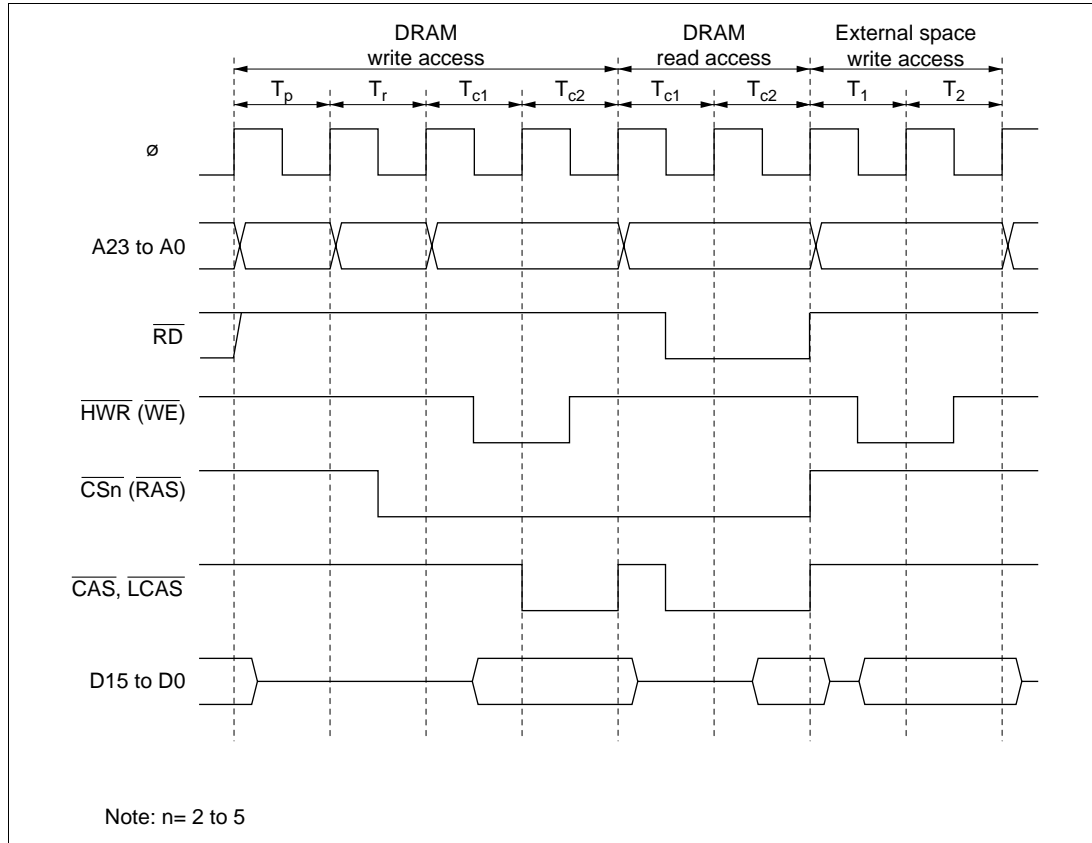


Figure 7-23 Example Operation Timing in RAS Down Mode

- RAS up mode

To select RAS up mode, clear the RCDM bit of the MCR to 0. If DRAM access is interrupted to access another area, the RAS signal level returns to High. Burst operation is only possible when the DRAM space is contiguous. Figure 7-24 shows example timing in RAS up mode.

Note that the  $\overline{\text{RAS}}$  signal level does not return to High in burst ROM space access.



**Figure 7-24 Example Operation Timing in RAS Up Mode**



### 7.5.11 Refresh Control

This LSI has a DRAM refresh control function. There are two refresh methods: (1) CAS-before-RAS (CBR) and (2), self refresh.

#### (1) CAS-Before-RAS (CBR) Refresh

To select CBR refresh, set the RFSHE bit of DRAMCR to 1 and clear the RMODE bit to 0.

In CBR refresh, the input clock selected with the CKS2 to CKS0 bits of DRAMCR are used for the RTCNT count-up. Refresh control is performed when the count reaches the value set in RTCOR (compare match). The RTCNT is then reset and the count again started from H'00. That is, the refresh is repeated at the set interval determined by RTCOR and CKS2 to CKS0. Set RTCOR and CKS2 to CKS0 to satisfy the refresh cycle for the DRAM being used.

The RTCNT count up starts when the CKS2 to CKS0 bits are set. The RTCNT and RTCOR values should therefore be set before setting CKS2 to CKS0. When a value is set in RTCOR, RTCNT is cleared. When RTCNT is set at the same time that it is reset by a compare match, the value written to RTCNT takes precedence.

When performing refresh control (RFSHE=1), do not clear the CMF flag.

Figure 7-25 shows RTCNT operation. Figure 7-26 shows compare match timing. And figure 7-27 show CBR refresh timing.

Some types of DRAM do not allow the  $\overline{WE}$  signal to be changed during the refresh cycle. In this case, set CBRM to 1. Figure 7-28 shows the timing. The  $\overline{CS}$  signal is not controlled and a Low level is output when an access request occurs.

Note that other normal spaces are accessed during the CBR refresh cycle.

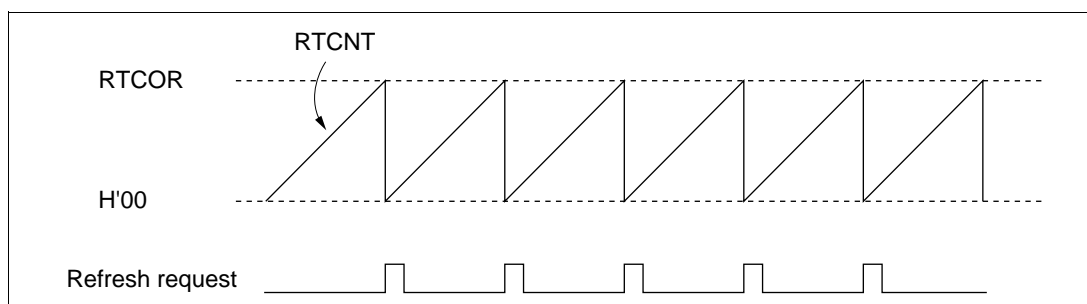
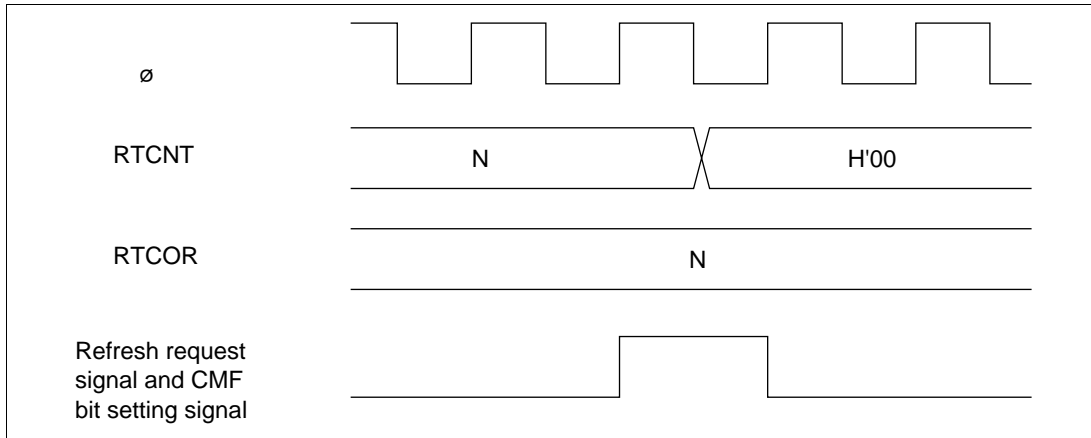
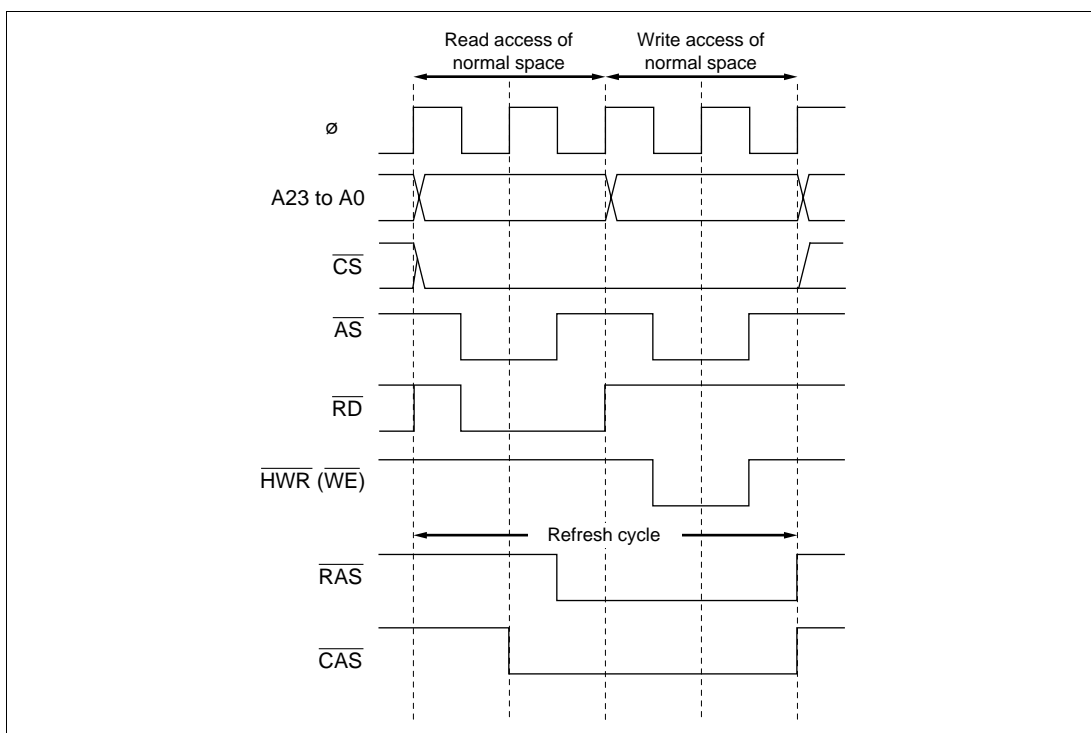


Figure 7-25 RTCNT Operation



**Figure 7-26 Compare Match Timing**



**Figure 7-27 Example CBR Refresh Timing (CBRM=0)**

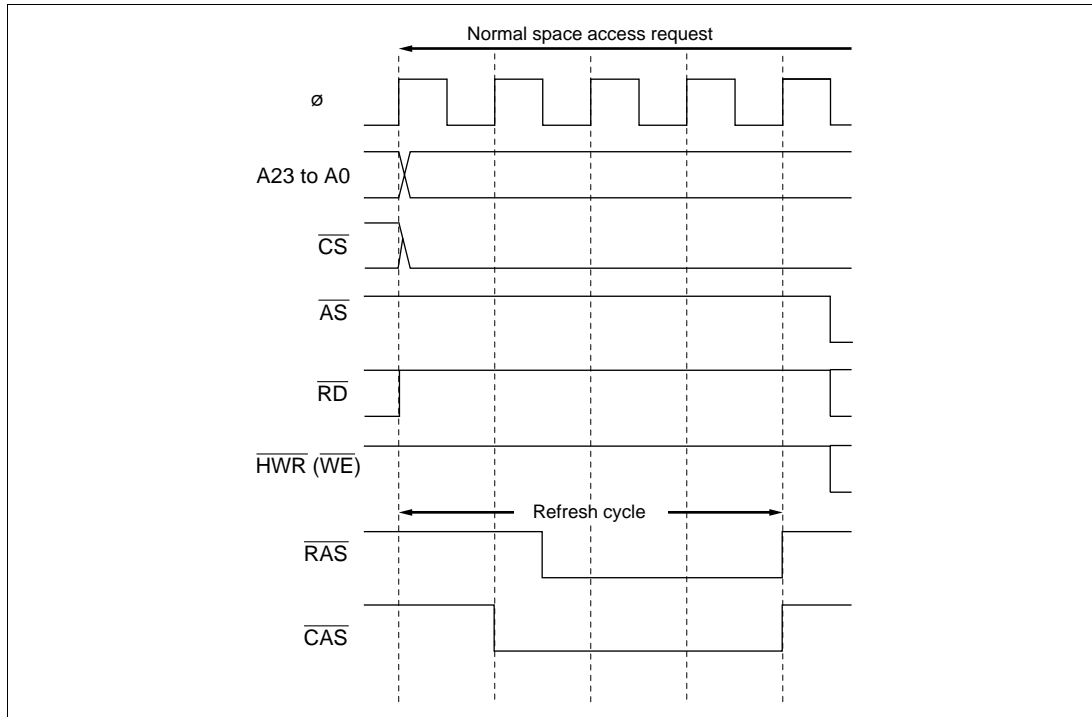


Figure 7-28 Example CBR Refresh Timing (CBRM=1)

## (2) Self-Refresh

One of the DRAM standby modes is the self-refresh mode (battery backup mode), in which the DRAM generates its own refresh timing and refresh address.

To select self-refresh, set the RFSHE bit and RMODE bits of the DRAMCR to 1. Next, execute a SLEEP instruction to make a transition to software standby mode. As shown in figure 7-29, the  $\overline{\text{CAS}}$  and  $\overline{\text{RAS}}$  signals are output and the DRAM enters self-refresh mode.

When you exit software standby mode, the RMODE bit is cleared to 0 and self-refresh mode is exited.

When making a transition to software standby mode, self-refresh mode starts after a CBR refresh, providing there is a CBR refresh request. CBR refresh requests occurring immediately before entering software standby mode are cleared on completion of the self-refresh when the software standby mode is exited.

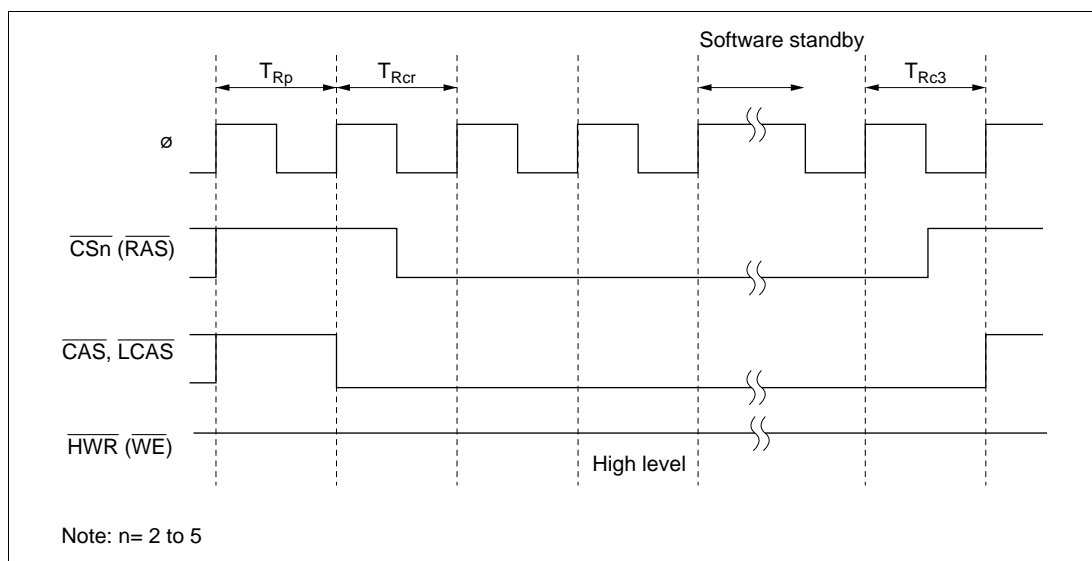


Figure 7-29 Self-Refresh Timing

## 7.6 DMAC Single Address Mode and DRAM Interface

(This function is not available in the H8S/2695)

When burst mode is set for the DRAM interface, the DDS bit selects the output timing for the  $\overline{\text{DACK}}$  signal. It also selects whether or not to perform burst access when accessing the DRAM space in DMAC single address mode.

### 7.6.1 DDS=1

Burst access is performed on the basis of the address only, regardless of the bus master. The  $\overline{\text{DACK}}$  output level changes to Low after the  $T_{c1}$  state in the case of the DRAM interface.

Figure 7-30 shows the  $\overline{\text{DACK}}$  output timing for the DRAM interface when DDS=1.

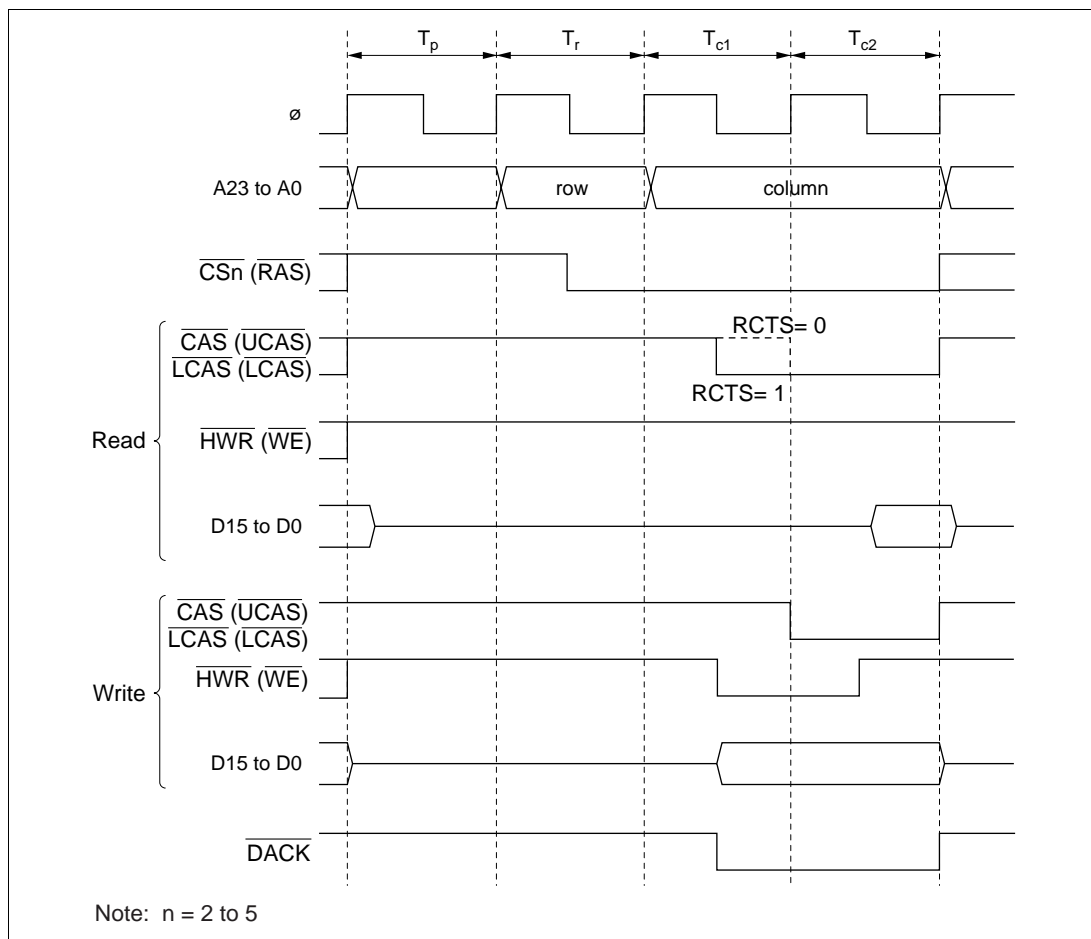


Figure 7-30  $\overline{\text{DACK}}$  Output Timing when DDS=1 (Example Showing DRAM Access)

### 7.6.2 DDS=0

When the DRAM space is accessed in DMAC single address mode, always perform full access (normal access). The  $\overline{\text{DACK}}$  output level changes to Low after the  $T_r$  state in the case of the DRAM interface.

In other than DMAC single address mode, burst access is possible when the DRAM space is accessed.

Figure 7-31 shows the  $\overline{\text{DACK}}$  output timing for the DRAM interface when DDS=0.

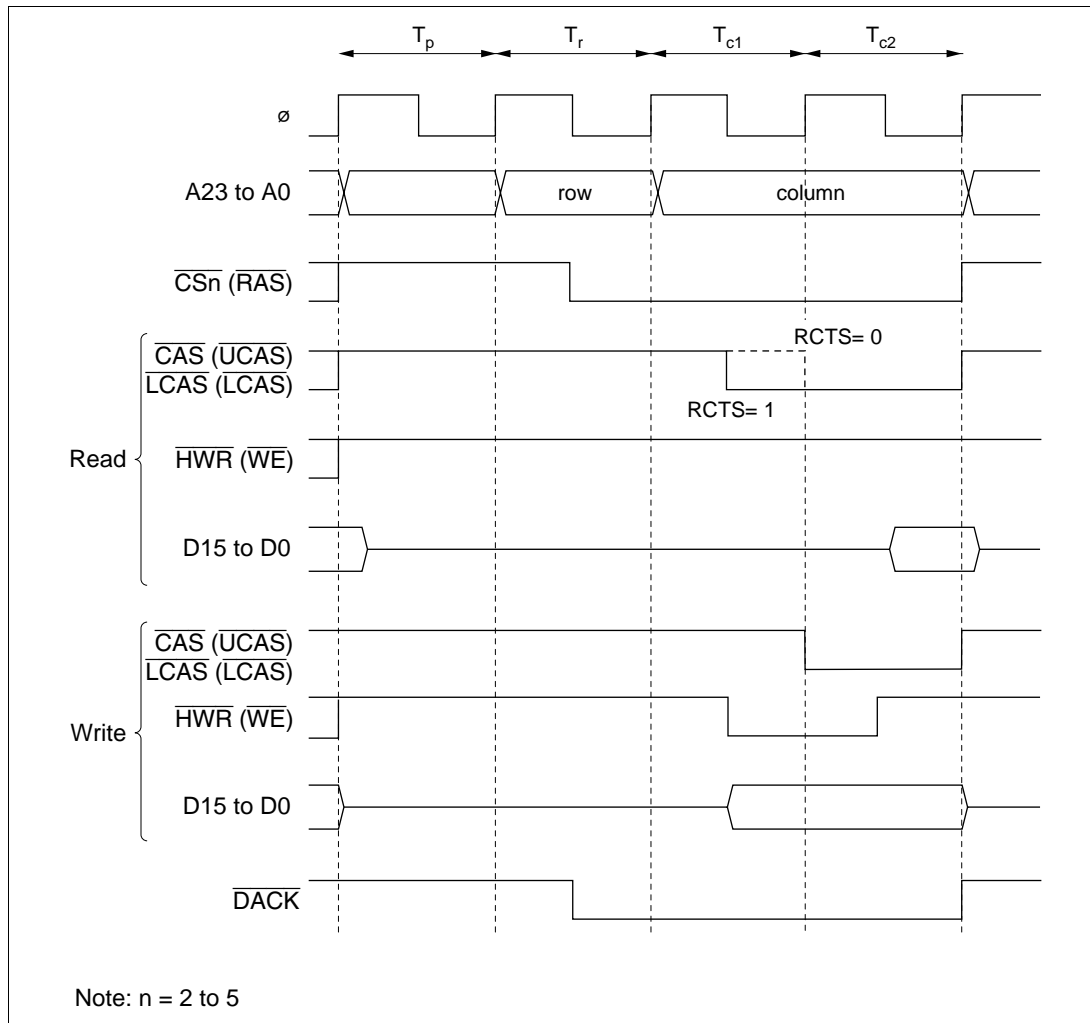


Figure 7-31  $\overline{\text{DACK}}$  Output Timing when DDS=0 (Example Showing DRAM Access)

## 7.7 Burst ROM Interface

### 7.7.1 Overview

In this LSI, the area 0 external space can be set as burst ROM space and burst ROM interfacing performed. Burst ROM space interfacing allows 16-bit ROM capable of burst access to be accessed at high-speed.

The BRSTRM bit of BCRH sets area 0 as burst ROM space. CPU instruction fetches (only) can be performed using a maximum of 4-word or 8-word continuous burst access. 1 state or 2 states can be selected in the case of burst access.

### 7.7.2 Basic Timing

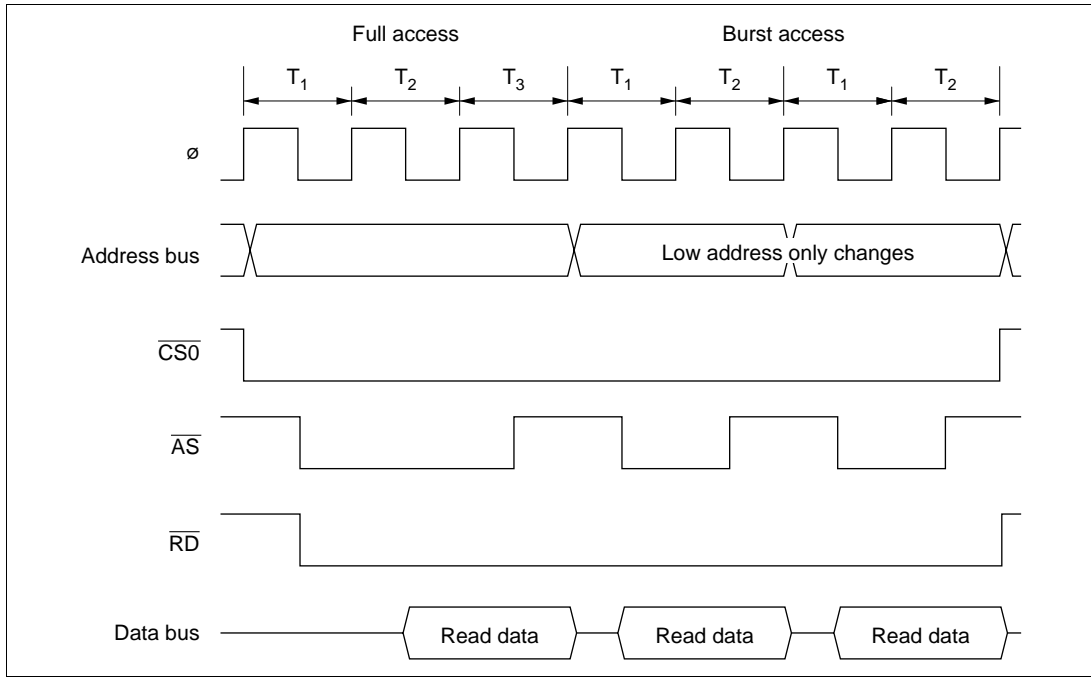
The AST0 bit of ASTCR sets the number of access states in the initial cycle (full access) of the burst ROM interface. Wait states can be inserted when the AST0 bit is set to 1. The burst cycle can be set for 1 state or 2 states by setting the BRSTS1 bit of BCRH. Wait states cannot be inserted. When area 0 is set as burst ROM space, area 0 is a 16-bit access space regardless of the ABW0 bit of ABWCR.

When the BRSTS0 bit of BCRH is cleared to 0, 4-word max. burst access is performed. When the BRSTS0 bit is set to 1, 8-word max. burst access is performed.

Figure 7-32 (a) and (b) shows the basic access timing for the burst ROM space.

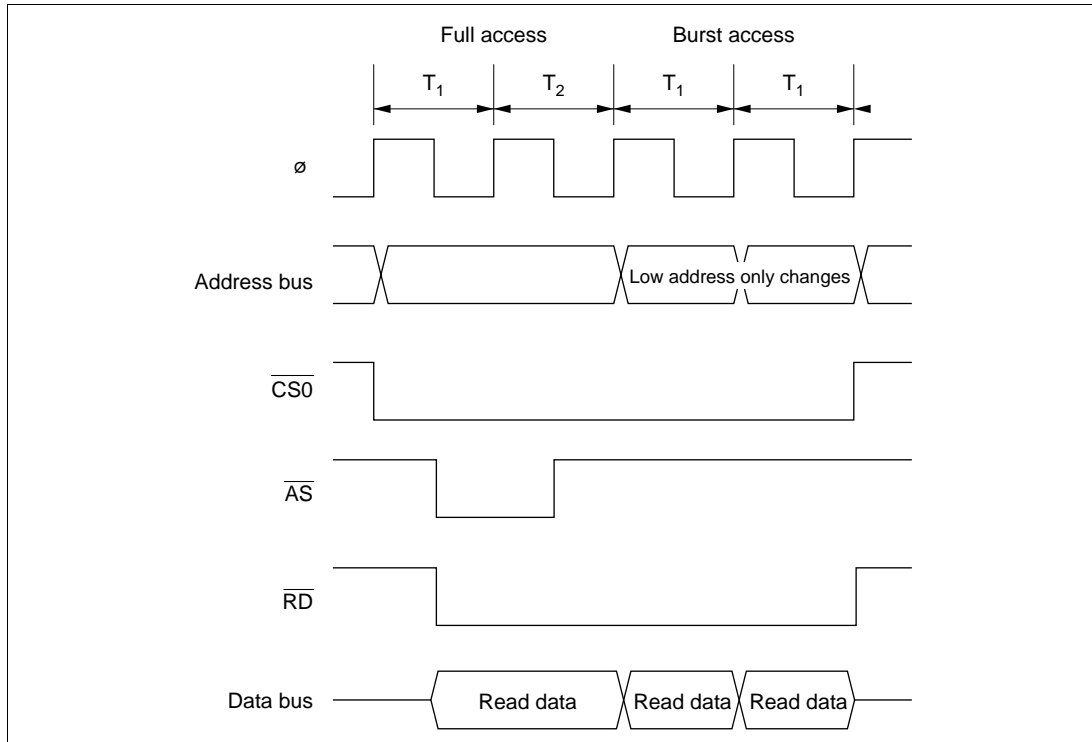
Figure 7-32 (a) is an example when both the AST0 and BRSTS1 bits are set to 1.

Figure 7-32 (b) is an example when both the AST0 and BRSTS1 bits are set to 0.



**Figure 7-32 (a) Example Burst ROM Access Timing (AST0=BRSTS1=1)**





**Figure 7-32 (b) Example Burst ROM Access Timing (AST0=BRSTS1=0)**

### 7.7.3 Wait Control

As with the basic bus interface, either program wait insertion or pin wait insertion using the  $\overline{WAIT}$  pin can be used in the initial cycle (full access) of the burst ROM interface. See section 7.4.5, Wait Control.

Wait states cannot be inserted in the burst cycle.

## 7.8 Idle Cycle

### 7.8.1 Operation

When the H8S/2633 Series accesses external space, it can insert a 1-state idle cycle ( $T_1$ ) between bus cycles in the following two cases: (1) when read accesses between different areas occur consecutively, and (2) when a write cycle occurs immediately after a read cycle. By inserting an idle cycle it is possible, for example, to avoid data collisions between ROM, with a long output floating time, and high-speed memory, I/O interfaces, and so on.

#### (1) Consecutive Reads between Different Areas

If consecutive reads between different areas occur while the ICIS1 bit in BCRH is set to 1, an idle cycle is inserted at the start of the second read cycle.

Figure 7-33 shows an example of the operation in this case. In this example, bus cycle A is a read cycle from ROM with a long output floating time, and bus cycle B is a read cycle from SRAM, each being located in a different area. In (a), an idle cycle is not inserted, and a collision occurs in cycle B between the read data from ROM and that from SRAM. In (b), an idle cycle is inserted, and a data collision is prevented.

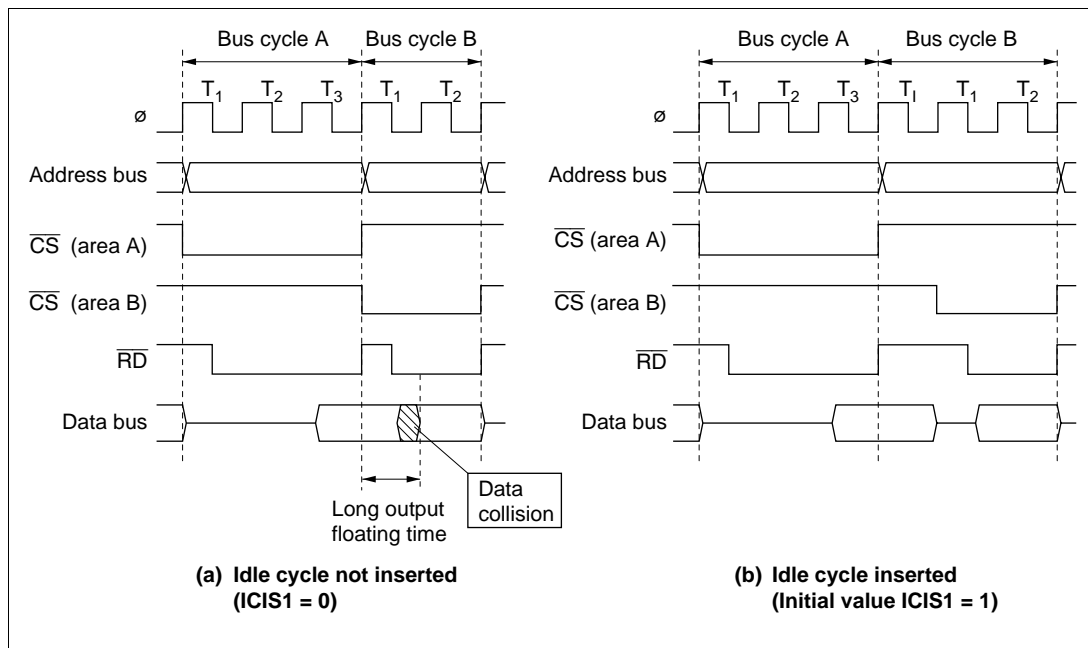


Figure 7-33 Example of Idle Cycle Operation (1)

## (2) Write after Read

If an external write occurs after an external read while the ICIS0 bit in BCRH is set to 1, an idle cycle is inserted at the start of the write cycle.

Figure 7-34 shows an example of the operation in this case. In this example, bus cycle A is a read cycle from ROM with a long output floating time, and bus cycle B is a CPU write cycle. In (a), an idle cycle is not inserted, and a collision occurs in cycle B between the read data from ROM and the CPU write data. In (b), an idle cycle is inserted, and a data collision is prevented.

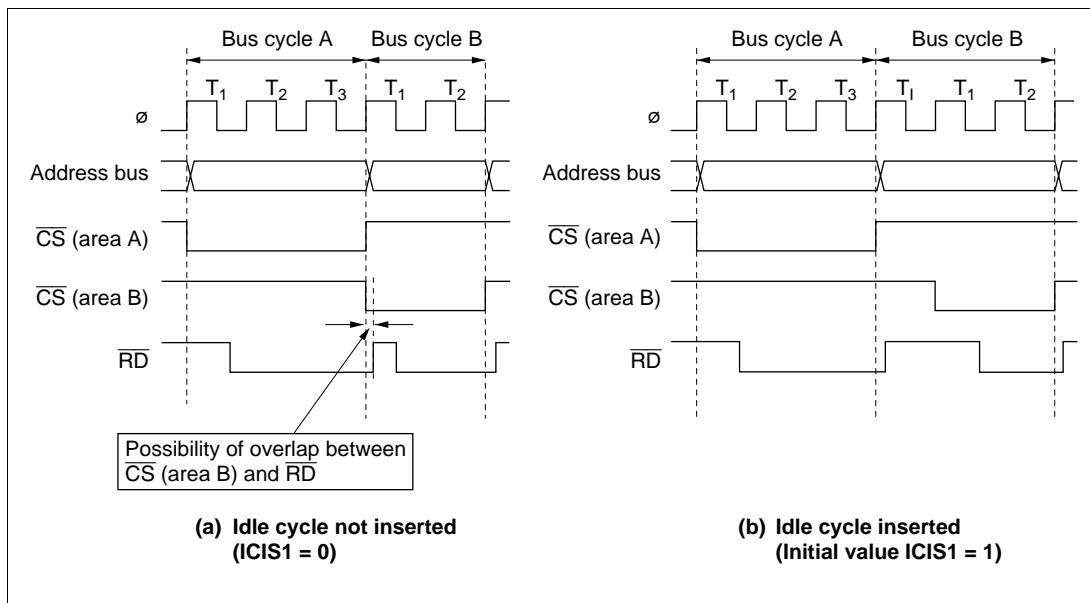


Figure 7-34 Example of Idle Cycle Operation (2)

### (3) Relationship between Chip Select ( $\overline{CS}$ ) Signal and Read ( $\overline{RD}$ ) Signal

Depending on the system's load conditions, the  $\overline{RD}$  signal may lag behind the  $\overline{CS}$  signal. An example is shown in figure 7-35.

In this case, with the setting for no idle cycle insertion (a), there may be a period of overlap between the bus cycle A  $\overline{RD}$  signal and the bus cycle B  $\overline{CS}$  signal.

Setting idle cycle insertion, as in (b), however, will prevent any overlap between the  $\overline{RD}$  and  $\overline{CS}$  signals.

In the initial state after reset release, idle cycle insertion (b) is set.

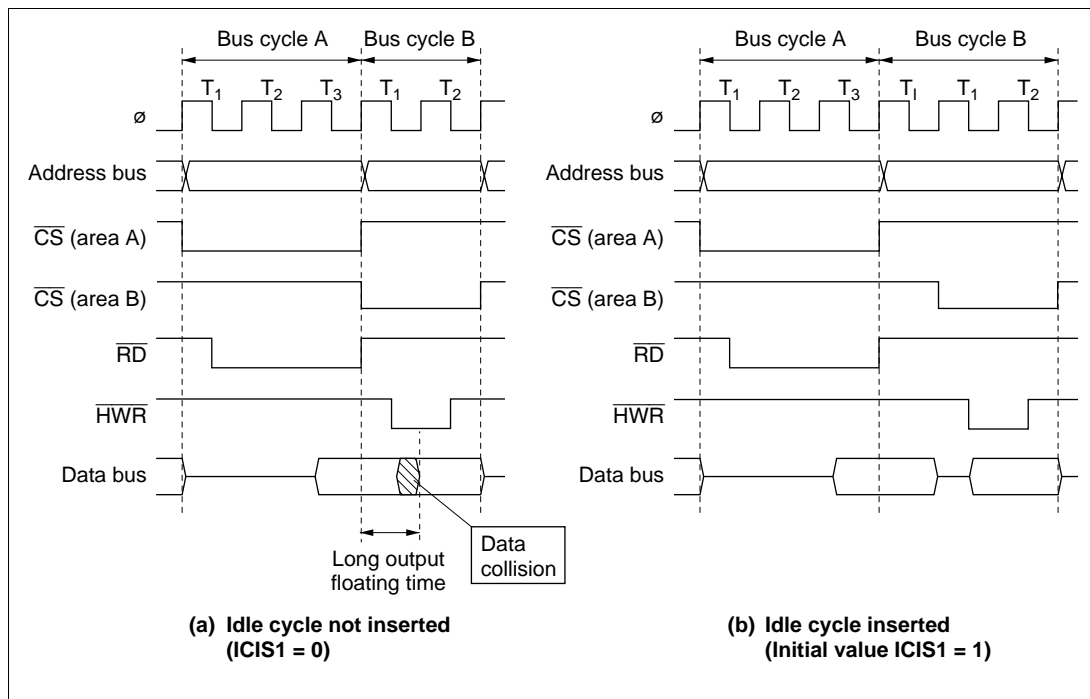
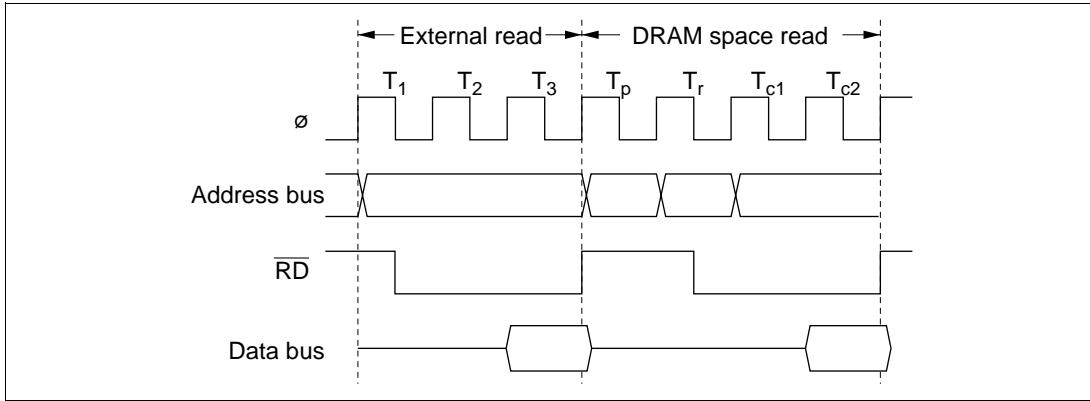


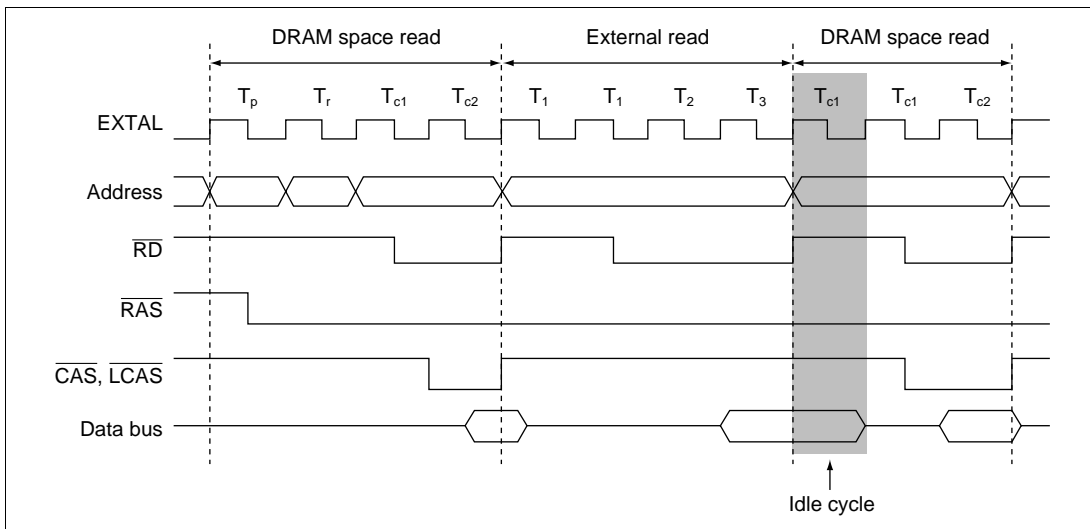
Figure 7-35 Relationship between Chip Select ( $\overline{CS}$ ) and Read ( $\overline{RD}$ )

**(4) Notes**

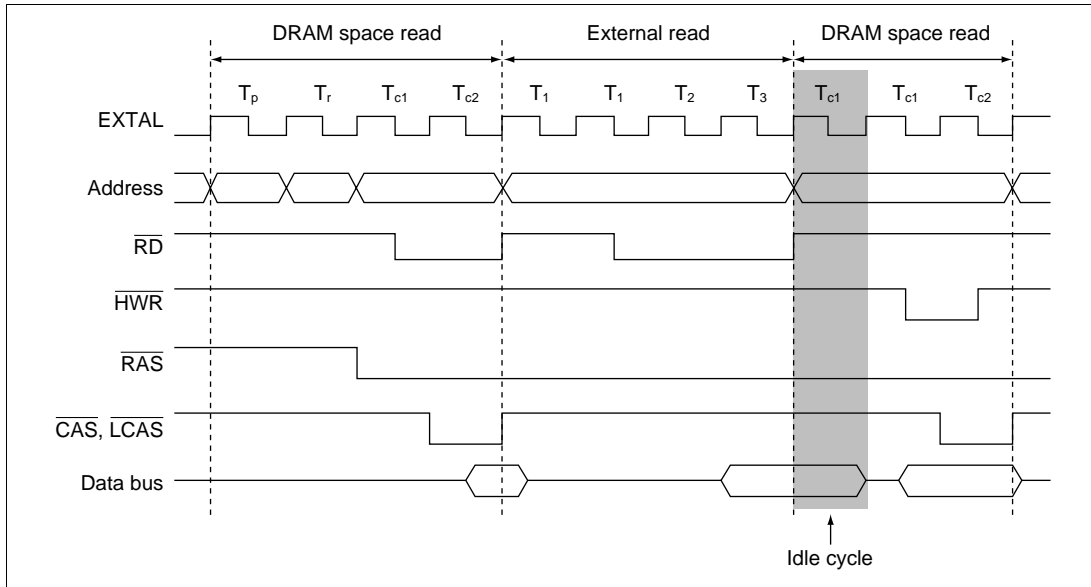
The setting of the ICIS0 and ICIS1 bits is invalid when accessing the DRAM space. For example, if the 2nd of successive reads of different areas is a DRAM access, only the  $T_p$  cycle is inserted, not the  $T_1$  cycle. Figure 7-36 shows the timing. Note, however, that ICIS0 and ICIS1 settings are valid in burst access in RAS down mode, and an idle cycle is inserted. Figure 7-37 (a) and (b) shows the timing.



**Figure 7-36 Example of DRAM Access after External Read**



**Figure 7-37 (a) Example Idle Cycle Operation in RAS Down Mode (ICIS1=1)**



**Figure 7-37 (b) Example Idle Cycle Operation in RAS Down Mode (ICIS0=1)**

### 7.8.2 Pin States in Idle Cycle

Table 7-8 shows pin states in an idle cycle.

**Table 7-8 Pin States in Idle Cycle**

Pins	Pin State
A23 to A0	Contents of next bus cycle
D15 to D0	High impedance
$\overline{CS}_n$	High*
$\overline{CAS}$	High
$\overline{AS}$	High
$\overline{RD}$	High
HWR	High
LWR	High
$\overline{DACK}_n$	High

Note: \* Remains low in DRAM space RAS down mode or a refresh cycle.

## 7.9 Write Data Buffer Function

The H8S/2633 Series has a write data buffer function in the external data bus. Using the write data buffer function enables external writes and DMA single address mode transmission to be executed in parallel with internal accesses. The write data buffer function is made available by setting the WDBE bit in BCRL to 1.

Figure 7-38 shows an example of the timing when the write data buffer function is used. When this function is used, if an external write and DMA single address mode transmission continues for 2 states or longer, and there is an internal access next, only an external write is executed in the first state, but from the next state onward an internal access (on-chip memory or internal I/O register read) is executed in parallel with the external write rather than waiting until it ends.

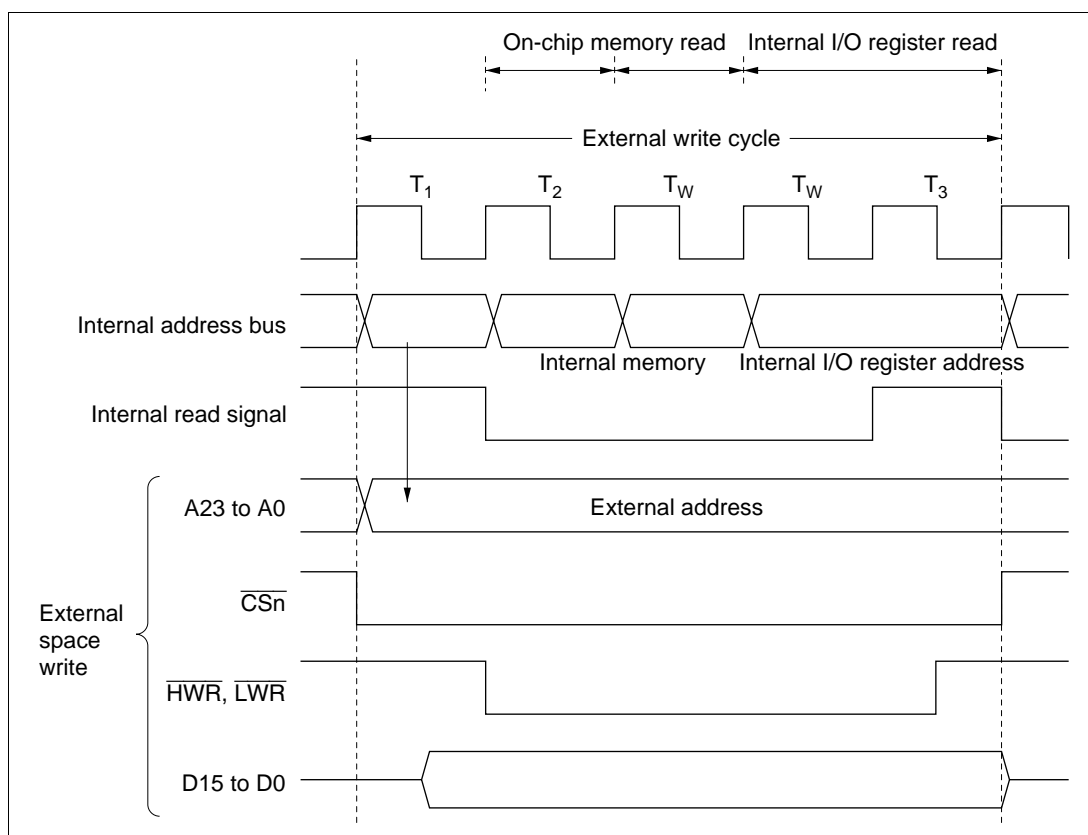


Figure 7-38 Example of Timing when Write Data Buffer Function is Used

## 7.10 Bus Release

### 7.10.1 Overview

The H8S/2633 Series can release the external bus in response to a bus request from an external device. In the external bus released state, the internal bus master continues to operate as long as there is no external access.

If an internal bus master wants to make an external access and when a refresh request occurs in the external bus released state, it can issue a bus request off-chip.

### 7.10.2 Operation

In external expansion mode, the bus can be released to an external device by setting the BRLE bit in BCRL to 1. Driving the  $\overline{\text{BREQ}}$  pin low issues an external bus request to the H8S/2633 Series. When the  $\overline{\text{BREQ}}$  pin is sampled, at the prescribed timing the  $\overline{\text{BACK}}$  pin is driven low, and the address bus, data bus, and bus control signals are placed in the high-impedance state, establishing the external bus-released state.

In the external bus released state, an internal bus master can perform accesses using the internal bus. When an internal bus master wants to make an external access, it temporarily defers activation of the bus cycle, and waits for the bus request from the external bus master to be dropped. Also, when a refresh request occurs in the external bus released state, refresh control is deferred until the external bus master drops the bus request.

If the BREQOE bit in BCRL is set to 1, when an internal bus master wants to make an external access and when a refresh request occurs in the external bus released state, the  $\overline{\text{BREQO}}$  pin is driven low and a request can be made off-chip to drop the bus request.

When the  $\overline{\text{BREQ}}$  pin is driven high, the  $\overline{\text{BACK}}$  pin is driven high at the prescribed timing and the external bus released state is terminated.

The following shows the order of priority when an external bus release request, refresh request, and external access by the internal bus master occur simultaneously:

When CBRM=1

(High) Refresh > External bus release > External access by internal bus master (Low)

When CBRM=0

(High) Refresh > External bus release (Low)

(High) External bus release > External access by internal bus master (Low)

Note: A refresh can be executed at the same time as external access by the internal bus master.



### 7.10.3 Pin States in External Bus Released State

Table 7-9 shows pin states in the external bus released state.

**Table 7-9 Pin States in Bus Released State**

<b>Pins</b>	<b>Pin State</b>
A23 to A0	High impedance
D15 to D0	High impedance
$\overline{\text{CSn}}$	High impedance
$\overline{\text{CAS}}$	High impedance
$\overline{\text{AS}}$	High impedance
$\overline{\text{RD}}$	High impedance
$\overline{\text{HWR}}$	High impedance
$\overline{\text{LWR}}$	High impedance
$\overline{\text{DACKn}}$	High

### 7.10.4 Transition Timing

Figure 7-39 shows the timing for transition to the bus-released state.

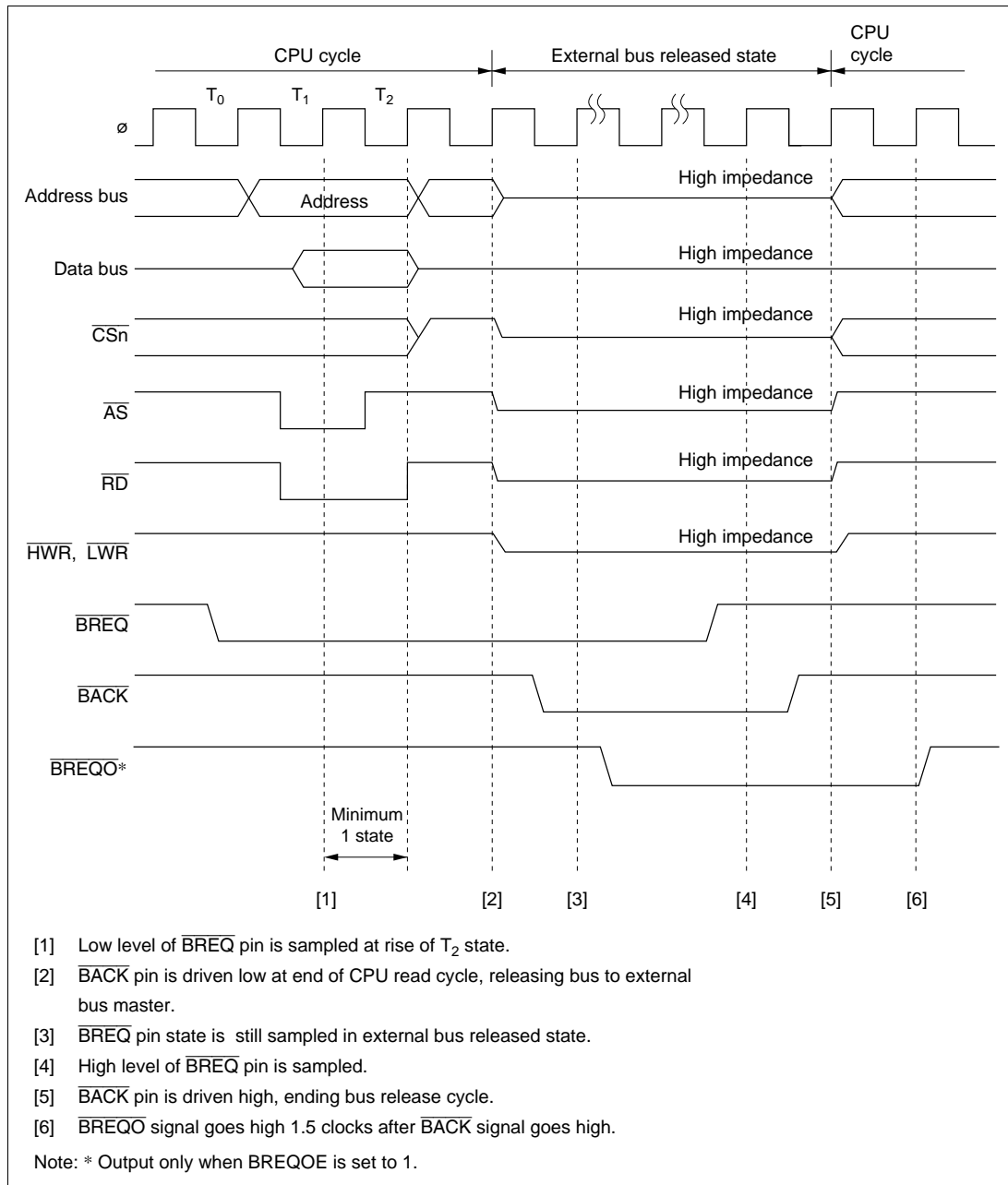
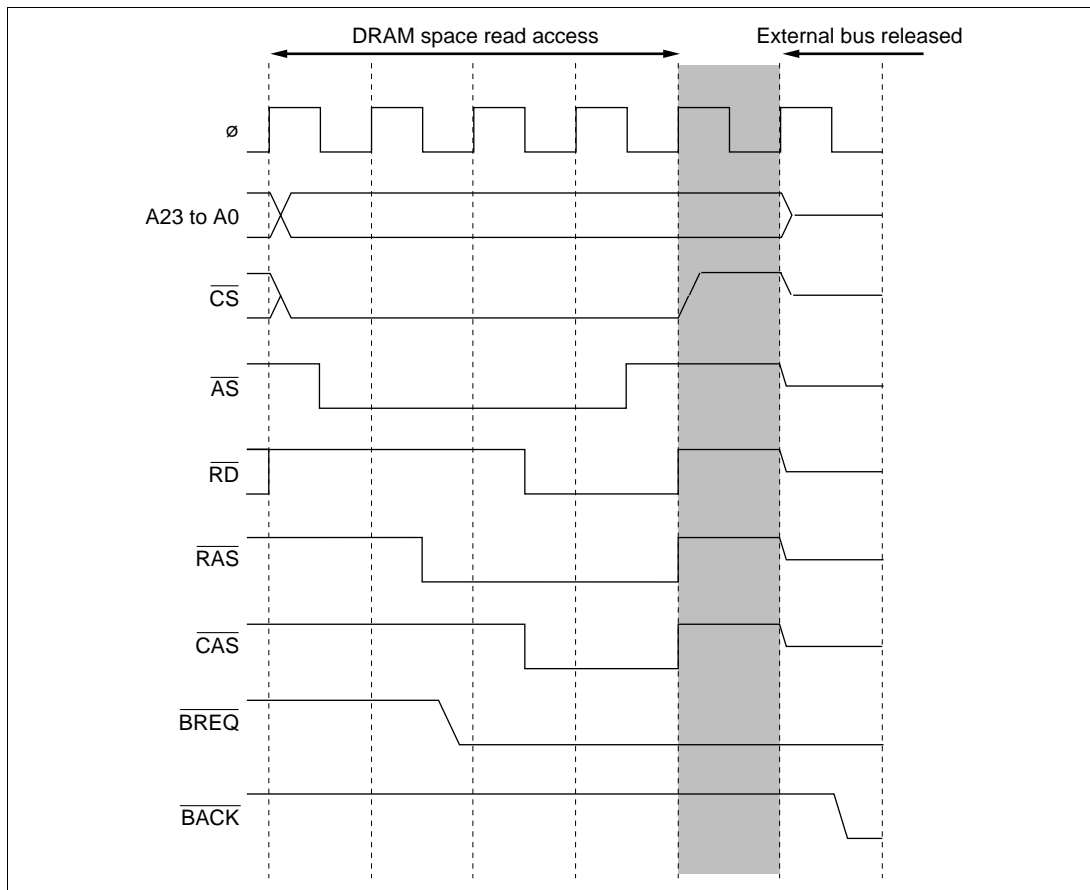


Figure 7-39 Bus-Released State Transition Timing



**Figure 7-40 Example Bus Release Transition Timing After DRAM Access (Reading DRAM)**

### 7.10.5 Notes

The external bus release function is deactivated when MSTPCR is set to H'FFFFFF or H'EFFFFFF and a transition is made to sleep mode. To use the external bus release function in sleep mode, do not set MSTPCR to H'FFFFFF and H'EFFFFFF.

When the CBRM bit is set to 1 to use the CBR refresh function, set the  $\overline{BREQ}=1$  width greater than the number of the slowest external access states. Otherwise, CBR refresh requests from the refresh timer may not be performed.

## 7.11 Bus Arbitration

(DMAC and DTC functions are not available in the H8S/2695)

### 7.11.1 Overview

The H8S/2633 Series has a bus arbiter that arbitrates bus master operations.

There are two bus masters, the CPU, DTC, and DMAC which perform read/write operations when they have possession of the bus. Each bus master requests the bus by means of a bus request signal. The bus arbiter determines priorities at the prescribed timing, and permits use of the bus by means of a bus request acknowledge signal. The selected bus master then takes possession of the bus and begins its operation.

### 7.11.2 Operation

The bus arbiter detects the bus masters' bus request signals, and if the bus is requested, sends a bus request acknowledge signal to the bus master making the request. If there are bus requests from more than one bus master, the bus request acknowledge signal is sent to the one with the highest priority. When a bus master receives the bus request acknowledge signal, it takes possession of the bus until that signal is canceled.

The order of priority of the bus masters is as follows:

(High) DMAC > DTC > CPU (Low)

An internal bus access by an internal bus master, external bus release, and refresh can be executed in parallel.

In the event of simultaneous external bus release request, refresh request, and internal bus master external access request generation, the order of priority is as follows:

When CBRM=1

(High) Refresh > External bus release > External access by internal bus master (Low)

When CBRM=0

(High) Refresh > External bus release (Low)

(High) External bus release > External access by internal bus master (Low)

### 7.11.3 Bus Transfer Timing

Even if a bus request is received from a bus master with a higher priority than that of the bus master that has acquired the bus and is currently operating, the bus is not necessarily transferred immediately. There are specific times at which each bus master can relinquish the bus.

**CPU:** The CPU is the lowest-priority bus master, and if a bus request is received from the DTC and DMAC, the bus arbiter transfers the bus to the bus master that issued the request. The timing for transfer of the bus is as follows:

- The bus is transferred at a break between bus cycles. However, if a bus cycle is executed in discrete operations, as in the case of a longword-size access, the bus is not transferred between the operations. See Appendix A.5, Bus States During Instruction Execution, for timings at which the bus is not transferred.
- If the CPU is in sleep mode, it transfers the bus immediately.

**DTC:** The DTC sends the bus arbiter a request for the bus when an activation request is generated.

The DTC can release the bus after a vector read, a register information read (3 states), a single data transfer, or a register information write (3 states). It does not release the bus during a register information read (3 states), a single data transfer, or a register information write (3 states).

**DMAC:** When a start request occurs, the DMAC requests the bus arbiter for bus privileges.

The DMAC releases bus privileges on completion of one transmission in short address mode, normal mode external requests, and cycle steal mode.

The DMAC releases the bus on completion of the transmission of one block in block transmission mode, or after a transmission in burst mode.

## 7.12 Resets and the Bus Controller

In a power-on reset, the H8S/2633 Series, including the bus controller, enters the reset state at that point, and an executing bus cycle is discontinued.

The bus controller registers and internal states are retained at a manual reset. The current external bus cycle is executed to completion. The  $\overline{\text{WAIT}}$  input is ignored. Write data is not retained. Also, because the DMAC\* is initialized at a manual reset,  $\overline{\text{DACK}}^*$  and  $\overline{\text{TEND}}^*$  outputs are disabled and function as I/O ports controlled by DDR and DR.

Note: \* This function is not available in the H8S/2695.



## Section 8 DMA Controller (DMAC)

(This function is not available in the H8S/2695)

### 8.1 Overview

The H8S/2633 Series has a built-in DMA controller (DMAC) which can carry out data transfer on up to 4 channels.

#### 8.1.1 Features

The features of the DMAC are listed below.

- Choice of short address mode or full address mode
  - Short address mode
    - Maximum of 4 channels can be used
    - Choice of dual address mode or single address mode
    - In dual address mode, one of the two addresses, transfer source and transfer destination, is specified as 24 bits and the other as 16 bits
    - In single address mode, transfer source or transfer destination address only is specified as 24 bits
    - In single address mode, transfer can be performed in one bus cycle
    - Choice of sequential mode, idle mode, or repeat mode for dual address mode and single address mode
  - Full address mode
    - Maximum of 2 channels can be used
    - Transfer source and transfer destination address specified as 24 bits
    - Choice of normal mode or block transfer mode
- 16-Mbyte address space can be specified directly
- Byte or word can be set as the transfer unit
- Activation sources: internal interrupt, external request, auto-request (depending on transfer mode)
  - Six 16-bit timer-pulse unit (TPU) compare match/input capture interrupts
  - Serial communication interface (SCI0, SCI1) transmit-data-empty interrupt, reception complete interrupt
  - A/D converter conversion end interrupt
  - External request
  - Auto-request

- Module stop mode can be set
  - The initial setting enables DMAC registers to be accessed. DMAC operation is halted by setting module stop mode

### 8.1.2 Block Diagram

A block diagram of the DMAC is shown in figure 8-1.

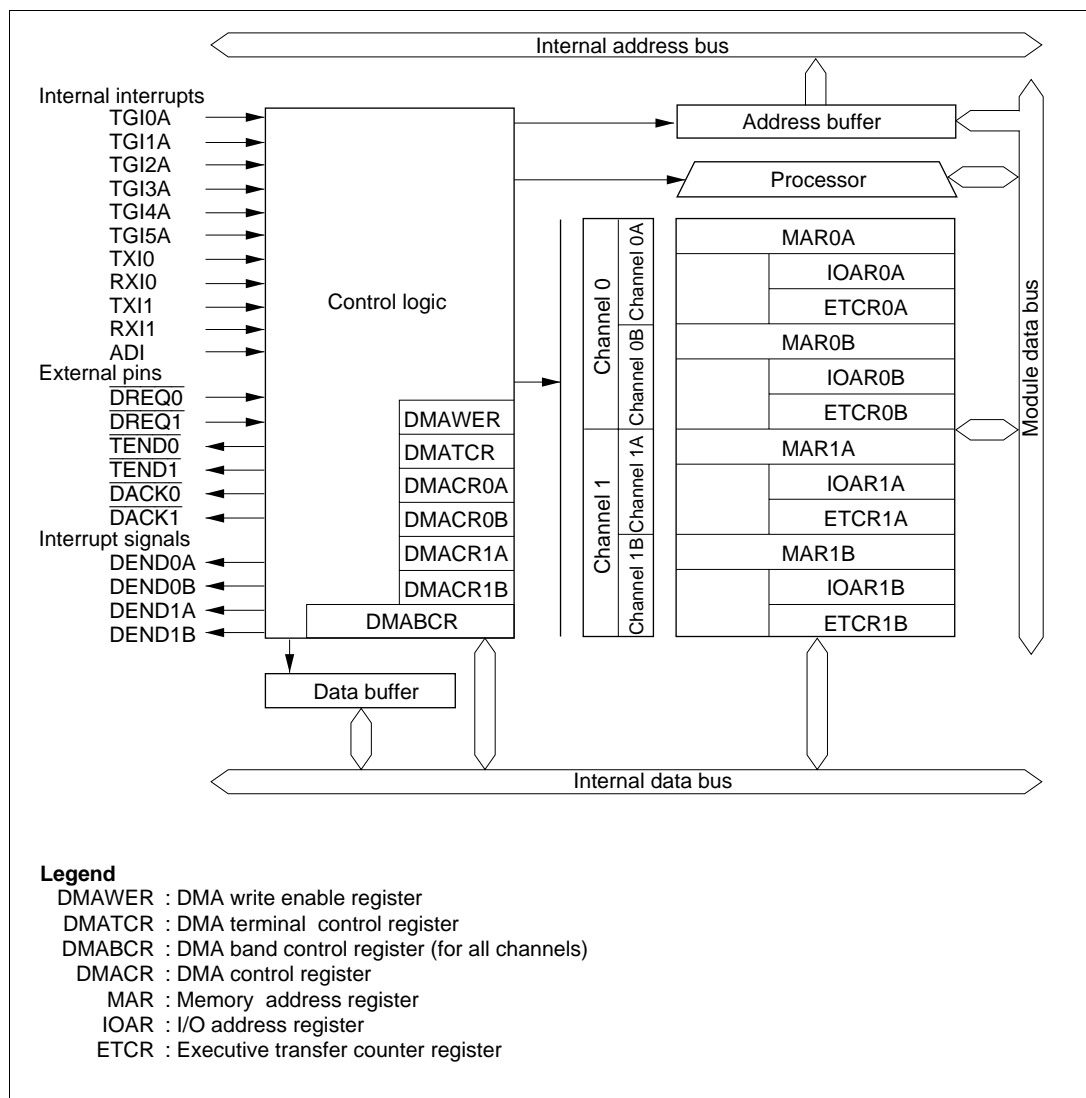


Figure 8-1 Block Diagram of DMAC



### 8.1.3 Overview of Functions

Tables 8-1 (1) and (2) summarize DMAC functions in short address mode and full address mode, respectively.

**Table 8-1 (1) Overview of DMAC Functions (Short Address Mode)**

Transfer Mode	Transfer Source	Address Register Bit Length	
		Source	Destination
Dual address mode	<ul style="list-style-type: none"> <li>TPU channel 0 to 5 compare match/input capture A interrupt</li> <li>SCI transmit-data-empty interrupt</li> <li>SCI reception complete interrupt</li> <li>A/D converter conversion end interrupt</li> <li>External request</li> </ul>	24/16	16/24
<ul style="list-style-type: none"> <li>Sequential mode               <ul style="list-style-type: none"> <li>1-byte or 1-word transfer executed for one transfer request</li> <li>Memory address incremented/decremented by 1 or 2</li> <li>1 to 65536 transfers</li> </ul> </li> <li>Idle mode               <ul style="list-style-type: none"> <li>1-byte or 1-word transfer executed for one transfer request</li> <li>Memory address fixed</li> <li>1 to 65536 transfers</li> </ul> </li> <li>Repeat mode               <ul style="list-style-type: none"> <li>1-byte or 1-word transfer executed for one transfer request</li> <li>Memory address incremented/decremented by 1 or 2</li> <li>After specified number of transfers (1 to 256), initial state is restored and operation continues</li> </ul> </li> </ul>			
Single address mode	<ul style="list-style-type: none"> <li>External request</li> </ul>	24/ $\overline{\text{DACK}}$	$\overline{\text{DACK}}$ /24
<ul style="list-style-type: none"> <li>1-byte or 1-word transfer executed for one transfer request</li> <li>Transfer in 1 bus cycle using <math>\overline{\text{DACK}}</math> pin in place of address specifying I/O</li> <li>Specifiable for sequential, idle, and repeat modes</li> </ul>			

**Table 8-1 (2) Overview of DMAC Functions (Full Address Mode)**

Transfer Mode	Transfer Source	Address Register Bit Length	
		Source	Destination
<ul style="list-style-type: none"> <li>• Normal mode</li> <li>  Auto-request               <ul style="list-style-type: none"> <li>— Transfer request retained internally</li> <li>— Transfers continue for the specified number of times (1 to 65536)</li> <li>— Choice of burst or cycle steal transfer</li> </ul> </li> <li>  External request               <ul style="list-style-type: none"> <li>— 1-byte or 1-word transfer executed for one transfer request</li> <li>— 1 to 65536 transfers</li> </ul> </li> </ul>	<ul style="list-style-type: none"> <li>• Auto-request</li> </ul>	24	24
<ul style="list-style-type: none"> <li>• Block transfer mode               <ul style="list-style-type: none"> <li>— Specified block size transfer executed for one transfer request</li> <li>— 1 to 65536 transfers</li> <li>— Either source or destination specifiable as block area</li> <li>— Block size: 1 to 256 bytes or words</li> </ul> </li> </ul>	<ul style="list-style-type: none"> <li>• TPU channel 0 to 5 compare match/input capture A interrupt</li> <li>• SCI transmit-data-empty interrupt</li> <li>• SCI reception complete interrupt</li> <li>• External request</li> <li>• A/D converter conversion end interrupt</li> </ul>	24	24

### 8.1.4 Pin Configuration

Table 8-2 summarizes the DMAC pins.

In short address mode, external request transfer, single address transfer, and transfer end output are not performed for channel A.

The DMA transfer acknowledge function is used in channel B single address mode in short address mode.

When the  $\overline{\text{DREQ}}$  pin is used, do not designate the corresponding port for output.

With regard to the  $\overline{\text{DACK}}$  pins, setting single address transfer automatically sets the corresponding port to output, functioning as a  $\overline{\text{DACK}}$  pin.

With regard to the  $\overline{\text{TEND}}$  pins, whether or not the corresponding port is used as a  $\overline{\text{TEND}}$  pin can be specified by means of a register setting.

**Table 8-2 DMAC Pins**

Channel	Pin Name	Symbol	I/O	Function
0	DMA request 0	$\overline{\text{DREQ0}}$	Input	DMAC channel 0 external request
	DMA transfer acknowledge 0	$\overline{\text{DACK0}}$	Output	DMAC channel 0 single address transfer acknowledge
	DMA transfer end 0	$\overline{\text{TEND0}}$	Output	DMAC channel 0 transfer end
1	DMA request 1	$\overline{\text{DREQ1}}$	Input	DMAC channel 1 external request
	DMA transfer acknowledge 1	$\overline{\text{DACK1}}$	Output	DMAC channel 1 single address transfer acknowledge
	DMA transfer end 1	$\overline{\text{TEND1}}$	Output	DMAC channel 1 transfer end

### 8.1.5 Register Configuration

Table 8-3 summarizes the DMAC registers.

**Table 8-3 DMAC Registers**

Channel	Name	Abbreviation	R/W	Initial Value	Address*	Bus Width
0	Memory address register 0A	MAR0A	R/W	Undefined	H'FEE0	16 bits
	I/O address register 0A	IOAR0A	R/W	Undefined	H'FEE4	16 bits
	Transfer count register 0A	ETCR0A	R/W	Undefined	H'FEE6	16 bits
	Memory address register 0B	MAR0B	R/W	Undefined	H'FEE8	16 bits
	I/O address register 0B	IOAR0B	R/W	Undefined	H'FEEC	16 bits
	Transfer count register 0B	ETCR0B	R/W	Undefined	H'FEEE	16 bits
1	Memory address register 1A	MAR1A	R/W	Undefined	H'FEF0	16 bits
	I/O address register 1A	IOAR1A	R/W	Undefined	H'FEF4	16 bits
	Transfer count register 1A	ETCR1A	R/W	Undefined	H'FEF6	16 bits
	Memory address register 1B	MAR1B	R/W	Undefined	H'FEF8	16 bits
	I/O address register 1B	IOAR1B	R/W	Undefined	H'FEFC	16 bits
	Transfer count register 1B	ETCR1B	R/W	Undefined	H'FEFE	16 bits
0, 1	DMA write enable register	DMAWER	R/W	H'00	H'FF60	8 bits
	DMA terminal control register	DMATCR	R/W	H'00	H'FF61	8 bits
	DMA control register 0A	DMACR0A	R/W	H'00	H'FF62	16 bits
	DMA control register 0B	DMACR0B	R/W	H'00	H'FF63	16 bits
	DMA control register 1A	DMACR1A	R/W	H'00	H'FF64	16 bits
	DMA control register 1B	DMACR1B	R/W	H'00	H'FF65	16 bits
	DMA band control register	DMABCR	R/W	H'0000	H'FF66	16 bits
	Module stop control register A	MSTPCRA	R/W	H'3F	H'FDE8	8 bits

Note: \* Lower 16 bits of the address.

## 8.2 Register Descriptions (1) (Short Address Mode)

Short address mode transfer can be performed for channels A and B independently.

Short address mode transfer is specified for each channel by clearing the FAE bit in DMABCR to 0, as shown in table 8-4. Short address mode or full address mode can be selected for channels 1 and 0 independently by means of bits FAE1 and FAE0.

**Table 8-4 Short Address Mode and Full Address Mode (For 1 Channel: Example of Channel 0)**

FAE0	Description																
0	Short address mode specified (channels A and B operate independently)																
Channel 0A	<table border="1" style="display: inline-table; vertical-align: middle;"> <tr><td colspan="2" style="text-align: center;">MAR0A</td></tr> <tr><td style="width: 20px;"></td><td style="text-align: center;">IOAR0A</td></tr> <tr><td style="width: 20px;"></td><td style="text-align: center;">ETCR0A</td></tr> <tr><td style="width: 20px;"></td><td style="text-align: center;">DMACR0A</td></tr> </table> <div style="display: inline-block; vertical-align: middle; margin-left: 10px;"> <p>← Specifies transfer source/transfer destination address</p> <p>← Specifies transfer destination/transfer source address</p> <p>← Specifies number of transfers</p> <p>← Specifies transfer size, mode, activation source, etc.</p> </div>	MAR0A			IOAR0A		ETCR0A		DMACR0A								
MAR0A																	
	IOAR0A																
	ETCR0A																
	DMACR0A																
Channel 0B	<table border="1" style="display: inline-table; vertical-align: middle;"> <tr><td colspan="2" style="text-align: center;">MAR0B</td></tr> <tr><td style="width: 20px;"></td><td style="text-align: center;">IOAR0B</td></tr> <tr><td style="width: 20px;"></td><td style="text-align: center;">ETCR0B</td></tr> <tr><td style="width: 20px;"></td><td style="text-align: center;">DMACR0B</td></tr> </table> <div style="display: inline-block; vertical-align: middle; margin-left: 10px;"> <p>← Specifies transfer source/transfer destination address</p> <p>← Specifies transfer destination/transfer source address</p> <p>← Specifies number of transfers</p> <p>← Specifies transfer size, mode, activation source, etc.</p> </div>	MAR0B			IOAR0B		ETCR0B		DMACR0B								
MAR0B																	
	IOAR0B																
	ETCR0B																
	DMACR0B																
1	Full address mode specified (channels A and B operate in combination)																
Channel 0	<table border="1" style="display: inline-table; vertical-align: middle;"> <tr><td colspan="2" style="text-align: center;">MAR0A</td></tr> <tr><td colspan="2" style="text-align: center;">MAR0B</td></tr> <tr><td style="width: 20px;"></td><td style="text-align: center;">IOAR0A</td></tr> <tr><td style="width: 20px;"></td><td style="text-align: center;">IOAR0B</td></tr> <tr><td style="width: 20px;"></td><td style="text-align: center;">ETCR0A</td></tr> <tr><td style="width: 20px;"></td><td style="text-align: center;">ETCR0B</td></tr> <tr><td style="width: 20px;"></td><td style="text-align: center;">DMACR0A</td></tr> <tr><td style="width: 20px;"></td><td style="text-align: center;">DMACR0B</td></tr> </table> <div style="display: inline-block; vertical-align: middle; margin-left: 10px;"> <p>← Specifies transfer source address</p> <p>← Specifies transfer destination address</p> <p>← Not used</p> <p>← Not used</p> <p>← Specifies number of transfers</p> <p>← Specifies number of transfers (used in block transfer mode only)</p> <p>← Specifies transfer size, mode, activation source, etc.</p> </div>	MAR0A		MAR0B			IOAR0A		IOAR0B		ETCR0A		ETCR0B		DMACR0A		DMACR0B
MAR0A																	
MAR0B																	
	IOAR0A																
	IOAR0B																
	ETCR0A																
	ETCR0B																
	DMACR0A																
	DMACR0B																

### 8.2.1 Memory Address Registers (MAR)

Bit	:	31	30	29	28	27	26	25	24	23	22	21	20	19	18	17	16
MAR	:	—	—	—	—	—	—	—	—								
Initial value	:	0	0	0	0	0	0	0	0	*	*	*	*	*	*	*	*
R/W	:	—	—	—	—	—	—	—	—	R/W	R/W	R/W	R/W	R/W	R/W	R/W	R/W

Bit	:	15	14	13	12	11	10	9	8	7	6	5	4	3	2	1	0
MAR	:																
Initial value	:	*	*	*	*	*	*	*	*	*	*	*	*	*	*	*	*
R/W	:	R/W	R/W	R/W	R/W	R/W	R/W	R/W	R/W	R/W	R/W	R/W	R/W	R/W	R/W	R/W	R/W

\*: Undefined

MAR is a 32-bit readable/writable register that specifies the transfer source address or destination address.

The upper 8 bits of MAR are reserved: they are always read as 0, and cannot be modified.

Whether MAR functions as the source address register or as the destination address register can be selected by means of the DTDIR bit in DMACR.

MAR is incremented or decremented each time a byte or word transfer is executed, so that the address specified by MAR is constantly updated. For details, see section 8.2.4, DMA Control Register (DMACR).

MAR is not initialized by a reset or in standby mode.

## 8.2.2 I/O Address Register (IOAR)

Bit	:	15	14	13	12	11	10	9	8	7	6	5	4	3	2	1	0
IOAR	:	<input type="checkbox"/>	<input type="checkbox"/>	<input type="checkbox"/>	<input type="checkbox"/>	<input type="checkbox"/>	<input type="checkbox"/>	<input type="checkbox"/>	<input type="checkbox"/>	<input type="checkbox"/>	<input type="checkbox"/>	<input type="checkbox"/>	<input type="checkbox"/>	<input type="checkbox"/>	<input type="checkbox"/>	<input type="checkbox"/>	<input type="checkbox"/>
Initial value	:	*	*	*	*	*	*	*	*	*	*	*	*	*	*	*	*
R/W	:	R/W	R/W	R/W	R/W	R/W	R/W	R/W	R/W	R/W	R/W	R/W	R/W	R/W	R/W	R/W	R/W

\*: Undefined

IOAR is a 16-bit readable/writable register that specifies the lower 16 bits of the transfer source address or destination address. The upper 8 bits of the transfer address are automatically set to H'FF.

Whether IOAR functions as the source address register or as the destination address register can be selected by means of the DTDIR bit in DMACR.

IOAR is invalid in single address mode.

IOAR is not incremented or decremented each time a transfer is executed, so that the address specified by IOAR is fixed.

IOAR is not initialized by a reset or in standby mode.

## 8.2.3 Execute Transfer Count Register (ETCR)

ETCR is a 16-bit readable/writable register that specifies the number of transfers. The setting of this register is different for sequential mode and idle mode on the one hand, and for repeat mode on the other.

### (1) Sequential Mode and Idle Mode

#### Transfer Counter

Bit	:	15	14	13	12	11	10	9	8	7	6	5	4	3	2	1	0
ETCR	:	<input type="checkbox"/>	<input type="checkbox"/>	<input type="checkbox"/>	<input type="checkbox"/>	<input type="checkbox"/>	<input type="checkbox"/>	<input type="checkbox"/>	<input type="checkbox"/>	<input type="checkbox"/>	<input type="checkbox"/>	<input type="checkbox"/>	<input type="checkbox"/>	<input type="checkbox"/>	<input type="checkbox"/>	<input type="checkbox"/>	<input type="checkbox"/>
Initial value	:	*	*	*	*	*	*	*	*	*	*	*	*	*	*	*	*
R/W	:	R/W	R/W	R/W	R/W	R/W	R/W	R/W	R/W	R/W	R/W	R/W	R/W	R/W	R/W	R/W	R/W

\*: Undefined

In sequential mode and idle mode, ETCR functions as a 16-bit transfer counter (with a count range of 1 to 65536). ETCR is decremented by 1 each time a transfer is performed, and when the count reaches H'0000, the DTE bit in DMABCR is cleared, and transfer ends.

## (2) Repeat Mode

### Transfer Number Storage

Bit	:	15	14	13	12	11	10	9	8
ETCRH	:								
Initial value	:	*	*	*	*	*	*	*	*
R/W	:	R/W	R/W	R/W	R/W	R/W	R/W	R/W	R/W

### Transfer Counter

Bit	:	7	6	5	4	3	2	1	0
ETCRL	:								
Initial value	:	*	*	*	*	*	*	*	*
R/W	:	R/W	R/W	R/W	R/W	R/W	R/W	R/W	R/W

\*: Undefined

In repeat mode, ETCR functions as transfer counter ETCRL (with a count range of 1 to 256) and transfer number storage register ETCRH. ETCRL is decremented by 1 each time a transfer is performed, and when the count reaches H'00, ETCRL is loaded with the value in ETCRH. At this point, MAR is automatically restored to the value it had when the count was started. The DTE bit in DMABCR is not cleared, and so transfers can be performed repeatedly until the DTE bit is cleared by the user.

ETCR is not initialized by a reset or in standby mode.

### 8.2.4 DMA Control Register (DMACR)

Bit	:	7	6	5	4	3	2	1	0
DMACR	:	DTSZ	DTID	RPE	DTDIR	DTF3	DTF2	DTF1	DTF0
Initial value	:	0	0	0	0	0	0	0	0
R/W	:	R/W	R/W	R/W	R/W	R/W	R/W	R/W	R/W

DMACR is an 8-bit readable/writable register that controls the operation of each DMAC channel.

DMACR is initialized to H'00 by a reset, and in standby mode.



**Bit 7—Data Transfer Size (DTSZ):** Selects the size of data to be transferred at one time.

**Bit 7**

DTSZ	Description	
0	Byte-size transfer	(Initial value)
1	Word-size transfer	

**Bit 6—Data Transfer Increment/Decrement (DTID):** Selects incrementing or decrementing of MAR every data transfer in sequential mode or repeat mode.

In idle mode, MAR is neither incremented nor decremented.

**Bit 6**

DTID	Description	
0	MAR is incremented after a data transfer <ul style="list-style-type: none"> <li>• When DTSZ = 0, MAR is incremented by 1 after a transfer</li> <li>• When DTSZ = 1, MAR is incremented by 2 after a transfer</li> </ul>	(Initial value)
1	MAR is decremented after a data transfer <ul style="list-style-type: none"> <li>• When DTSZ = 0, MAR is decremented by 1 after a transfer</li> <li>• When DTSZ = 1, MAR is decremented by 2 after a transfer</li> </ul>	

**Bit 5—Repeat Enable (RPE):** Used in combination with the DTIE bit in DMABCR to select the mode (sequential, idle, or repeat) in which transfer is to be performed.

Bit 5		DMABCR	
RPE	DTIE	Description	
0	0	Transfer in sequential mode (no transfer end interrupt)	(Initial value)
	1	Transfer in sequential mode (with transfer end interrupt)	
1	0	Transfer in repeat mode (no transfer end interrupt)	
	1	Transfer in idle mode (with transfer end interrupt)	

For details of operation in sequential, idle, and repeat mode, see section 8.5.2, Sequential Mode, section 8.5.3, Idle Mode, and section 8.5.4, Repeat Mode.

**Bit 4—Data Transfer Direction (DTDIR):** Used in combination with the SAE bit in DMABCR to specify the data transfer direction (source or destination). The function of this bit is therefore different in dual address mode and single address mode.

**DMABCR Bit 4**

SAE	DTDIR	Description
0	0	Transfer with MAR as source address and IOAR as destination address (Initial value)
	1	Transfer with IOAR as source address and MAR as destination address
1	0	Transfer with MAR as source address and $\overline{\text{DACK}}$ pin as write strobe
	1	Transfer with $\overline{\text{DACK}}$ pin as read strobe and MAR as destination address

**Bits 3 to 0—Data Transfer Factor (DTF3 to DTF0):** These bits select the data transfer factor (activation source). There are some differences in activation sources for channel A and for channel B.

**Channel A**

Bit 3	Bit 2	Bit 1	Bit 0	Description
DTF3	DTF2	DTF1	DTF0	
0	0	0	0	— (Initial value)
			1	Activated by A/D converter conversion end interrupt
		1	0	—
			1	—
	1	0	0	Activated by SCI channel 0 transmit-data-empty interrupt
			1	Activated by SCI channel 0 reception complete interrupt
		1	0	Activated by SCI channel 1 transmit-data-empty interrupt
			1	Activated by SCI channel 1 reception complete interrupt
1	0	0	0	Activated by TPU channel 0 compare match/input capture A interrupt
			1	Activated by TPU channel 1 compare match/input capture A interrupt
		1	0	Activated by TPU channel 2 compare match/input capture A interrupt
			1	Activated by TPU channel 3 compare match/input capture A interrupt
	1	0	0	Activated by TPU channel 4 compare match/input capture A interrupt
			1	Activated by TPU channel 5 compare match/input capture A interrupt
		1	0	—
			1	—

### Channel B

Bit 3	Bit 2	Bit 1	Bit 0	Description
DTF3	DTF2	DTF1	DTF0	
0	0	0	0	— (Initial value)
			1	Activated by A/D converter conversion end interrupt
		1	0	Activated by $\overline{\text{DREQ}}$ pin falling edge input*
			1	Activated by $\overline{\text{DREQ}}$ pin low-level input
	1	0	0	Activated by SCI channel 0 transmit-data-empty interrupt
			1	Activated by SCI channel 0 reception complete interrupt
		1	0	Activated by SCI channel 1 transmit-data-empty interrupt
			1	Activated by SCI channel 1 reception complete interrupt
1	0	0	0	Activated by TPU channel 0 compare match/input capture A interrupt
			1	Activated by TPU channel 1 compare match/input capture A interrupt
		1	0	Activated by TPU channel 2 compare match/input capture A interrupt
			1	Activated by TPU channel 3 compare match/input capture A interrupt
	1	0	0	Activated by TPU channel 4 compare match/input capture A interrupt
			1	Activated by TPU channel 5 compare match/input capture A interrupt
		1	0	—
			1	—

Note: \* Detected as a low level in the first transfer after transfer is enabled.

The same factor can be selected for more than one channel. In this case, activation starts with the highest-priority channel according to the relative channel priorities. For relative channel priorities, see section 8.5.13, DMAC Multi-Channel Operation.

### 8.2.5 DMA Band Control Register (DMABCR)

Bit	:	15	14	13	12	11	10	9	8
DMABCRH:		F AE1	F AE0	S AE1	S AE0	D TA1B	D TA1A	D TA0B	D TA0A
Initial value:		0	0	0	0	0	0	0	0
R/W	:	R/W	R/W	R/W	R/W	R/W	R/W	R/W	R/W
Bit	:	7	6	5	4	3	2	1	0
DMABCR L:		D TE1B	D TE1A	D TE0B	D TE0A	D TIE1B	D TIE1A	D TIE0B	D TIE0A
Initial value:		0	0	0	0	0	0	0	0
R/W	:	R/W	R/W	R/W	R/W	R/W	R/W	R/W	R/W

DMABCR is a 16-bit readable/writable register that controls the operation of each DMAC channel.

DMABCR is initialized to H'0000 by a reset, and in standby mode.

**Bit 15—Full Address Enable 1 (FAE1):** Specifies whether channel 1 is to be used in short address mode or full address mode.

In short address mode, channels 1A and 1B are used as independent channels.

#### Bit 15

FAE1	Description
0	Short address mode (Initial value)
1	Full address mode

**Bit 14—Full Address Enable 0 (FAE0):** Specifies whether channel 0 is to be used in short address mode or full address mode.

In short address mode, channels 0A and 0B are used as independent channels.

#### Bit 14

FAE0	Description
0	Short address mode (Initial value)
1	Full address mode

**Bit 13—Single Address Enable 1 (SAE1):** Specifies whether channel 1B is to be used for transfer in dual address mode or single address mode.

**Bit 13**

SAE1	Description
0	Transfer in dual address mode (Initial value)
1	Transfer in single address mode

This bit is invalid in full address mode.

**Bit 12—Single Address Enable 0 (SAE0):** Specifies whether channel 0B is to be used for transfer in dual address mode or single address mode.

**Bit 12**

SAE0	Description
0	Transfer in dual address mode (Initial value)
1	Transfer in single address mode

This bit is invalid in full address mode.

**Bits 11 to 8—Data Transfer Acknowledge (DTA):** These bits enable or disable clearing, when DMA transfer is performed, of the internal interrupt source selected by the data transfer factor setting.

When DTE = 1 and DTA = 1, the internal interrupt source selected by the data transfer factor setting is cleared automatically by DMA transfer. When DTE = 1 and DTA = 0, the internal interrupt source selected by the data transfer factor setting does not issue an interrupt request to the CPU or DTC.

When DTE = 0 and DTA = 0, the internal interrupt source selected by the data transfer factor setting is not cleared when a transfer is performed, and can issue an interrupt request to the CPU or DTC in parallel. In this case, the interrupt source should be cleared by the CPU or DTC transfer.

When DTE = 0, the internal interrupt source selected by the data transfer factor setting issues an interrupt request to the CPU or DTC regardless of the DTA bit setting.

**Bit 11—Data Transfer Acknowledge 1B (DTA1B):** Enables or disables clearing, when DMA transfer is performed, of the internal interrupt source selected by the channel 1B data transfer factor setting.

**Bit 11**

DTA1B	Description
0	Clearing of selected internal interrupt source at time of DMA transfer is disabled (Initial value)
1	Clearing of selected internal interrupt source at time of DMA transfer is enabled

**Bit 10—Data Transfer Acknowledge 1A (DTA1A):** Enables or disables clearing, when DMA transfer is performed, of the internal interrupt source selected by the channel 1A data transfer factor setting.

**Bit 10**

DTA1A	Description
0	Clearing of selected internal interrupt source at time of DMA transfer is disabled (Initial value)
1	Clearing of selected internal interrupt source at time of DMA transfer is enabled

**Bit 9—Data Transfer Acknowledge 0B (DTA0B):** Enables or disables clearing, when DMA transfer is performed, of the internal interrupt source selected by the channel 0B data transfer factor setting.

**Bit 9**

DTA0B	Description
0	Clearing of selected internal interrupt source at time of DMA transfer is disabled (Initial value)
1	Clearing of selected internal interrupt source at time of DMA transfer is enabled

**Bit 8—Data Transfer Acknowledge 0A (DTA0A):** Enables or disables clearing, when DMA transfer is performed, of the internal interrupt source selected by the channel 0A data transfer factor setting.

**Bit 8**

DTA0A	Description
0	Clearing of selected internal interrupt source at time of DMA transfer is disabled (Initial value)
1	Clearing of selected internal interrupt source at time of DMA transfer is enabled

**Bits 7 to 4—Data Transfer Enable (DTE):** When DTE = 0, data transfer is disabled and the activation source selected by the data transfer factor setting is ignored. If the activation source is an internal interrupt, an interrupt request is issued to the CPU or DTC. If the DTIE bit is set to 1

when DTE = 0, the DMAC regards this as indicating the end of a transfer, and issues a transfer end interrupt request to the CPU or DTC.

The conditions for the DTE bit being cleared to 0 are as follows:

- When initialization is performed
- When the specified number of transfers have been completed in a transfer mode other than repeat mode
- When 0 is written to the DTE bit to forcibly abort the transfer, or for a similar reason

When DTE = 1, data transfer is enabled and the DMAC waits for a request by the activation source selected by the data transfer factor setting. When a request is issued by the activation source, DMA transfer is executed.

The condition for the DTE bit being set to 1 is as follows:

- When 1 is written to the DTE bit after the DTE bit is read as 0

**Bit 7—Data Transfer Enable 1B (DTE1B):** Enables or disables data transfer on channel 1B.

**Bit 7**

DTE1B	Description
0	Data transfer disabled (Initial value)
1	Data transfer enabled

**Bit 6—Data Transfer Enable 1A (DTE1A):** Enables or disables data transfer on channel 1A.

**Bit 6**

DTE1A	Description
0	Data transfer disabled (Initial value)
1	Data transfer enabled

**Bit 5—Data Transfer Enable 0B (DTE0B):** Enables or disables data transfer on channel 0B.

**Bit 5**

DTE0B	Description
0	Data transfer disabled (Initial value)
1	Data transfer enabled

**Bit 4—Data Transfer Enable 0A (DTE0A):** Enables or disables data transfer on channel 0A.

**Bit 4**

<b>DTE0A</b>	<b>Description</b>	
0	Data transfer disabled	(Initial value)
1	Data transfer enabled	

**Bits 3 to 0—Data Transfer End Interrupt Enable (DTIE):** These bits enable or disable an interrupt to the CPU or DTC when transfer ends. If the DTIE bit is set to 1 when DTE = 0, the DMAC regards this as indicating the end of a transfer, and issues a transfer end interrupt request to the CPU or DTC.

A transfer end interrupt can be canceled either by clearing the DTIE bit to 0 in the interrupt handling routine, or by performing processing to continue transfer by setting the transfer counter and address register again, and then setting the DTE bit to 1.

**Bit 3—Data Transfer End Interrupt Enable 1B (DTIE1B):** Enables or disables the channel 1B transfer end interrupt.

**Bit 3**

<b>DTIE1B</b>	<b>Description</b>	
0	Transfer end interrupt disabled	(Initial value)
1	Transfer end interrupt enabled	

**Bit 2—Data Transfer End Interrupt Enable 1A (DTIE1A):** Enables or disables the channel 1A transfer end interrupt.

**Bit 2**

<b>DTIE1A</b>	<b>Description</b>	
0	Transfer end interrupt disabled	(Initial value)
1	Transfer end interrupt enabled	

**Bit 1—Data Transfer End Interrupt Enable 0B (DTIE0B):** Enables or disables the channel 0B transfer end interrupt.

**Bit 1**

<b>DTIE0B</b>	<b>Description</b>	
0	Transfer end interrupt disabled	(Initial value)
1	Transfer end interrupt enabled	

**Bit 0—Data Transfer End Interrupt Enable 0A (DTIE0A):** Enables or disables the channel 0A transfer end interrupt.



**Bit 0**

DTIE0A	Description	(Initial value)
0	Transfer end interrupt disabled	
1	Transfer end interrupt enabled	

**8.3 Register Descriptions (2) (Full Address Mode)**

Full address mode transfer is performed with channels A and B together. For details of full address mode setting, see table 8-4.

**8.3.1 Memory Address Register (MAR)**

Bit	:	31	30	29	28	27	26	25	24	23	22	21	20	19	18	17	16
MAR	:	—	—	—	—	—	—	—	—								
Initial value	:	0	0	0	0	0	0	0	0	*	*	*	*	*	*	*	*
R/W	:	—	—	—	—	—	—	—	—	R/W	R/W	R/W	R/W	R/W	R/W	R/W	R/W
Bit	:	15	14	13	12	11	10	9	8	7	6	5	4	3	2	1	0
MAR	:																
Initial value	:	*	*	*	*	*	*	*	*	*	*	*	*	*	*	*	*
R/W	:	R/W	R/W	R/W	R/W	R/W	R/W	R/W	R/W	R/W	R/W	R/W	R/W	R/W	R/W	R/W	R/W

\*: Undefined

MAR is a 32-bit readable/writable register; MARA functions as the transfer source address register, and MARB as the destination address register.

MAR is composed of two 16-bit registers, MARH and MARL. The upper 8 bits of MARH are reserved: they are always read as 0, and cannot be modified.

MAR is incremented or decremented each time a byte or word transfer is executed, so that the source or destination memory address can be updated automatically. For details, see section 8.3.4, DMA Control Register (DMACR).

MAR is not initialized by a reset or in standby mode.

**8.3.2 I/O Address Register (IOAR)**

IOAR is not used in full address transfer.

### 8.3.3 Execute Transfer Count Register (ETCR)

ETCR is a 16-bit readable/writable register that specifies the number of transfers. The function of this register is different in normal mode and in block transfer mode.

ETCR is not initialized by a reset or in standby mode.

#### (1) Normal Mode

ETCRA

##### Transfer Counter

Bit	:	15	14	13	12	11	10	9	8	7	6	5	4	3	2	1	0
ETCR	:																
Initial value	:	*	*	*	*	*	*	*	*	*	*	*	*	*	*	*	*
R/W	:	R/W	R/W	R/W	R/W	R/W	R/W	R/W	R/W	R/W	R/W	R/W	R/W	R/W	R/W	R/W	R/W

\*: Undefined

In normal mode, ETCRA functions as a 16-bit transfer counter. ETCRA is decremented by 1 each time a transfer is performed, and transfer ends when the count reaches H'0000. ETCRB is not used at this time.

ETCRB

ETCRB is not used in normal mode.

#### (2) Block Transfer Mode

ETCRA

##### Holds block size

Bit	:	15	14	13	12	11	10	9	8
ETCRAH	:								
Initial value	:	*	*	*	*	*	*	*	*
R/W	:	R/W	R/W	R/W	R/W	R/W	R/W	R/W	R/W

##### Block size counter

Bit	:	7	6	5	4	3	2	1	0
ETCRAL	:								
Initial value	:	*	*	*	*	*	*	*	*
R/W	:	R/W	R/W	R/W	R/W	R/W	R/W	R/W	R/W

\*: Undefined

## ETCRB

### Block Transfer Counter

Bit	:	15	14	13	12	11	10	9	8	7	6	5	4	3	2	1	0
ETCRB	:																
Initial value	:	*	*	*	*	*	*	*	*	*	*	*	*	*	*	*	*
R/W	:	R/W	R/W	R/W	R/W	R/W	R/W	R/W	R/W	R/W	R/W	R/W	R/W	R/W	R/W	R/W	R/W

In block transfer mode, ETCRAL functions as an 8-bit block size counter and ETCRAH holds the block size. ETCRAL is decremented each time a 1-byte or 1-word transfer is performed, and when the count reaches H'00, ETCRAL is loaded with the value in ETCRAH. So by setting the block size in ETCRAH and ETCRAL, it is possible to repeatedly transfer blocks consisting of any desired number of bytes or words.

ETCRB functions in block transfer mode, as a 16-bit block transfer counter. ETCRB is decremented by 1 each time a block is transferred, and transfer ends when the count reaches H'0000.

### 8.3.4 DMA Control Register (DMACR)

DMACR is a 16-bit readable/writable register that controls the operation of each DMAC channel. In full address mode, DMACRA and DMACRB have different functions.

DMACR is initialized to H'0000 by a reset, and in standby mode.

#### DMACRA

Bit	:	15	14	13	12	11	10	9	8
DMACRA	:	DTSZ	SAID	SAIDE	BLKDIR	BLKE	—	—	—
Initial value	:	0	0	0	0	0	0	0	0
R/W	:	R/W	R/W	R/W	R/W	R/W	R/W	R/W	R/W

#### DMACRB

Bit	:	7	6	5	4	3	2	1	0
DMACRB	:	—	DAID	DAIDE	—	DTF3	DTF2	DTF1	DTF0
Initial value	:	0	0	0	0	0	0	0	0
R/W	:	R/W	R/W	R/W	R/W	R/W	R/W	R/W	R/W

**Bit 15—Data Transfer Size (DTSZ):** Selects the size of data to be transferred at one time.

**Bit 15**

DTSZ	Description
0	Byte-size transfer (Initial value)
1	Word-size transfer

**Bit 14—Source Address Increment/Decrement (SAID)**

**Bit 13—Source Address Increment/Decrement Enable (SAIDE):** These bits specify whether source address register MARA is to be incremented, decremented, or left unchanged, when data transfer is performed.

Bit 14	Bit 13	Description
0	0	MARA is fixed (Initial value)
	1	MARA is incremented after a data transfer <ul style="list-style-type: none"> <li>When DTSZ = 0, MARA is incremented by 1 after a transfer</li> <li>When DTSZ = 1, MARA is incremented by 2 after a transfer</li> </ul>
1	0	MARA is fixed
	1	MARA is decremented after a data transfer <ul style="list-style-type: none"> <li>When DTSZ = 0, MARA is decremented by 1 after a transfer</li> <li>When DTSZ = 1, MARA is decremented by 2 after a transfer</li> </ul>

**Bit 12—Block Direction (BLKDIR)**

**Bit 11—Block Enable (BLKE):** These bits specify whether normal mode or block transfer mode is to be used. If block transfer mode is specified, the BLKDIR bit specifies whether the source side or the destination side is to be the block area.

Bit 12	Bit 11	Description
0	0	Transfer in normal mode (Initial value)
	1	Transfer in block transfer mode, destination side is block area
1	0	Transfer in normal mode
	1	Transfer in block transfer mode, source side is block area

For operation in normal mode and block transfer mode, see section 8.5, Operation.

**Bits 10 to 7—Reserved:** Can be read or written to.

**Bit 6—Destination Address Increment/Decrement (DAID)**

**Bit 5—Destination Address Increment/Decrement Enable (DAIDE):** These bits specify whether destination address register MARB is to be incremented, decremented, or left unchanged, when data transfer is performed.

Bit 6	Bit 5	Description
DAID	DAIDE	
0	0	MARB is fixed (Initial value)
	1	MARB is incremented after a data transfer <ul style="list-style-type: none"> <li>When DTSZ = 0, MARB is incremented by 1 after a transfer</li> <li>When DTSZ = 1, MARB is incremented by 2 after a transfer</li> </ul>
1	0	MARB is fixed
	1	MARB is decremented after a data transfer <ul style="list-style-type: none"> <li>When DTSZ = 0, MARB is decremented by 1 after a transfer</li> <li>When DTSZ = 1, MARB is decremented by 2 after a transfer</li> </ul>

**Bit 4—Reserved:** Can be read or written to.

**Bits 3 to 0—Data Transfer Factor (DTF3 to DTF0):** These bits select the data transfer factor (activation source). The factors that can be specified differ between normal mode and block transfer mode.

- Normal Mode

Bit 3	Bit 2	Bit 1	Bit 0	Description		
DTF3	DTF2	DTF1	DTF0			
0	0	0	0	— (Initial value)		
			1	—		
	1	0	1	0	Activated by $\overline{\text{DREQ}}$ pin falling edge input	
				1	Activated by $\overline{\text{DREQ}}$ pin low-level input	
			1	1	0	Auto-request (cycle steal)
					1	Auto-request (burst)
1	*	*	*	—		

\*: Don't care

- Block Transfer Mode

Bit 3	Bit 2	Bit 1	Bit 0	Description
DTF3	DTF2	DTF1	DTF0	
0	0	0	0	— (Initial value)
			1	Activated by A/D converter conversion end interrupt
		1	0	Activated by $\overline{\text{DREQ}}$ pin falling edge input*
		1	1	Activated by $\overline{\text{DREQ}}$ pin low-level input
	1	0	0	Activated by SCI channel 0 transmit-data-empty interrupt
	1		1	Activated by SCI channel 0 reception complete interrupt
		1	0	Activated by SCI channel 1 transmit-data-empty interrupt
			1	Activated by SCI channel 1 reception complete interrupt
1	0	0	0	Activated by TPU channel 0 compare match/input capture A interrupt
			1	Activated by TPU channel 1 compare match/input capture A interrupt
		1	0	Activated by TPU channel 2 compare match/input capture A interrupt
			1	Activated by TPU channel 3 compare match/input capture A interrupt
	1	0	0	Activated by TPU channel 4 compare match/input capture A interrupt
			1	Activated by TPU channel 5 compare match/input capture A interrupt
		1	0	—
			1	—

Note: \* Detected as a low level in the first transfer after transfer is enabled.

The same factor can be selected for more than one channel. In this case, activation starts with the highest-priority channel according to the relative channel priorities. For relative channel priorities, see section 8.5.13, DMAC Multi-Channel Operation.

### 8.3.5 DMA Band Control Register (DMABCR)

Bit	:	15	14	13	12	11	10	9	8
DMABCRH:		F AE1	F AE0	—	—	D TA1	—	D TA0	—
Initial value:		0	0	0	0	0	0	0	0
R/W	:	R/W	R/W	R/W	R/W	R/W	R/W	R/W	R/W

Bit	:	7	6	5	4	3	2	1	0
DMABCRL:		D TME1	D TE1	D TME0	D TE0	D TIE1B	D TIE1A	D TIE0B	D TIE0A
Initial value:		0	0	0	0	0	0	0	0
R/W	:	R/W	R/W	R/W	R/W	R/W	R/W	R/W	R/W

DMABCR is a 16-bit readable/writable register that controls the operation of each DMAC channel.

DMABCR is initialized to H'0000 by a reset, and in standby mode.

**Bit 15—Full Address Enable 1 (FAE1):** Specifies whether channel 1 is to be used in short address mode or full address mode.

In full address mode, channels 1A and 1B are used together as a single channel.

#### Bit 15

FAE1	Description
0	Short address mode (Initial value)
1	Full address mode

**Bit 14—Full Address Enable 0 (FAE0):** Specifies whether channel 0 is to be used in short address mode or full address mode.

In full address mode, channels 0A and 0B are used together as a single channel.

#### Bit 14

FAE0	Description
0	Short address mode (Initial value)
1	Full address mode

**Bits 13 and 12—Reserved:** Can be read or written to.

**Bits 11 and 9—Data Transfer Acknowledge (DTA):** These bits enable or disable clearing, when DMA transfer is performed, of the internal interrupt source selected by the data transfer factor setting.

When DTE = 1 and DTA = 1, the internal interrupt source selected by the data transfer factor setting is cleared automatically by DMA transfer. When DTE = 1 and DTA = 0, the internal interrupt source selected by the data transfer factor setting does not issue an interrupt request to the CPU or DTC.

When the DTE = 1 and the DTA = 0, the internal interrupt source selected by the data transfer factor setting is not cleared when a transfer is performed, and can issue an interrupt request to the CPU or DTC in parallel. In this case, the interrupt source should be cleared by the CPU or DTC transfer.

When the DTE = 0, the internal interrupt source selected by the data transfer factor setting issues an interrupt request to the CPU or DTC regardless of the DTA bit setting.

The state of the DTME bit does not affect the above operations.

**Bit 11—Data Transfer Acknowledge 1 (DTA1):** Enables or disables clearing, when DMA transfer is performed, of the internal interrupt source selected by the channel 1 data transfer factor setting.

**Bit 11**

DTA1	Description
0	Clearing of selected internal interrupt source at time of DMA transfer is disabled (Initial value)
1	Clearing of selected internal interrupt source at time of DMA transfer is enabled

**Bit 9—Data Transfer Acknowledge 0 (DTA0):** Enables or disables clearing, when DMA transfer is performed, of the internal interrupt source selected by the channel 0 data transfer factor setting.

**Bit 9**

DTA0	Description
0	Clearing of selected internal interrupt source at time of DMA transfer is disabled (Initial value)
1	Clearing of selected internal interrupt source at time of DMA transfer is enabled



**Bits 10 and 8—Reserved:** Can be read or written to.

**Bits 7 and 5—Data Transfer Master Enable (DTME):** Together with the DTE bit, these bits control enabling or disabling of data transfer on the relevant channel. When both the DTME bit and the DTE bit are set to 1, transfer is enabled for the channel.

If the relevant channel is in the middle of a burst mode transfer when an NMI interrupt is generated, the DTME bit is cleared, the transfer is interrupted, and bus mastership passes to the CPU. When the DTME bit is subsequently set to 1 again, the interrupted transfer is resumed. In block transfer mode, however, the DTME bit is not cleared by an NMI interrupt, and transfer is not interrupted.

The conditions for the DTME bit being cleared to 0 are as follows:

- When initialization is performed
- When NMI is input in burst mode
- When 0 is written to the DTME bit

The condition for DTME being set to 1 is as follows:

- When 1 is written to DTME after DTME is read as 0

**Bit 7—Data Transfer Master Enable 1 (DTME1):** Enables or disables data transfer on channel 1.

**Bit 7**

DTME1	Description
0	Data transfer disabled. In burst mode, cleared to 0 by an NMI interrupt (Initial value)
1	Data transfer enabled

**Bit 5—Data Transfer Master Enable 0 (DTME0):** Enables or disables data transfer on channel 0.

**Bit 5**

DTME0	Description
0	Data transfer disabled. In normal mode, cleared to 0 by an NMI interrupt (Initial value)
1	Data transfer enabled

**Bits 6 and 4—Data Transfer Enable (DTE):** When DTE = 0, data transfer is disabled and the activation source selected by the data transfer factor setting is ignored. If the activation source is an internal interrupt, an interrupt request is issued to the CPU or DTC. If the DTIE bit is set to 1 when DTE = 0, the DMAC regards this as indicating the end of a transfer, and issues a transfer end interrupt request to the CPU.

The conditions for the DTE bit being cleared to 0 are as follows:

- When initialization is performed
- When the specified number of transfers have been completed
- When 0 is written to the DTE bit to forcibly abort the transfer, or for a similar reason

When DTE = 1 and DTME = 1, data transfer is enabled and the DMAC waits for a request by the activation source selected by the data transfer factor setting. When a request is issued by the activation source, DMA transfer is executed.

The condition for the DTE bit being set to 1 is as follows:

- When 1 is written to the DTE bit after the DTE bit is read as 0

**Bit 6—Data Transfer Enable 1 (DTE1):** Enables or disables data transfer on channel 1.

**Bit 6**

DTE1	Description	
0	Data transfer disabled	(Initial value)
1	Data transfer enabled	

**Bit 4—Data Transfer Enable 0 (DTE0):** Enables or disables data transfer on channel 0.

**Bit 4**

DTE0	Description	
0	Data transfer disabled	(Initial value)
1	Data transfer enabled	

**Bits 3 and 1—Data Transfer Interrupt Enable B (DTIEB):** These bits enable or disable an interrupt to the CPU or DTC when transfer is interrupted. If the DTIEB bit is set to 1 when DTME = 0, the DMAC regards this as indicating a break in the transfer, and issues a transfer break interrupt request to the CPU or DTC.

A transfer break interrupt can be canceled either by clearing the DTIEB bit to 0 in the interrupt handling routine, or by performing processing to continue transfer by setting the DTME bit to 1.

**Bit 3—Data Transfer Interrupt Enable 1B (DTIE1B):** Enables or disables the channel 1 transfer break interrupt.

**Bit 3**

DTIE1B	Description
0	Transfer break interrupt disabled (Initial value)
1	Transfer break interrupt enabled

**Bit 1—Data Transfer Interrupt Enable 0B (DTIE0B):** Enables or disables the channel 0 transfer break interrupt.

**Bit 1**

DTIE0B	Description
0	Transfer break interrupt disabled (Initial value)
1	Transfer break interrupt enabled

**Bits 2 and 0—Data Transfer End Interrupt Enable A (DTIEA):** These bits enable or disable an interrupt to the CPU or DTC when transfer ends. If DTIEA bit is set to 1 when DTE = 0, the DMAC regards this as indicating the end of a transfer, and issues a transfer end interrupt request to the CPU or DTC.

A transfer end interrupt can be canceled either by clearing the DTIEA bit to 0 in the interrupt handling routine, or by performing processing to continue transfer by setting the transfer counter and address register again, and then setting the DTE bit to 1.

**Bit 2—Data Transfer End Interrupt Enable 1A (DTIE1A):** Enables or disables the channel 1 transfer end interrupt.

**Bit 2**

DTIE1A	Description
0	Transfer end interrupt disabled (Initial value)
1	Transfer end interrupt enabled

**Bit 0—Data Transfer End Interrupt Enable 0A (DTIE0A):** Enables or disables the channel 0 transfer end interrupt.

**Bit 0**

DTIE0A	Description
0	Transfer end interrupt disabled (Initial value)
1	Transfer end interrupt enabled

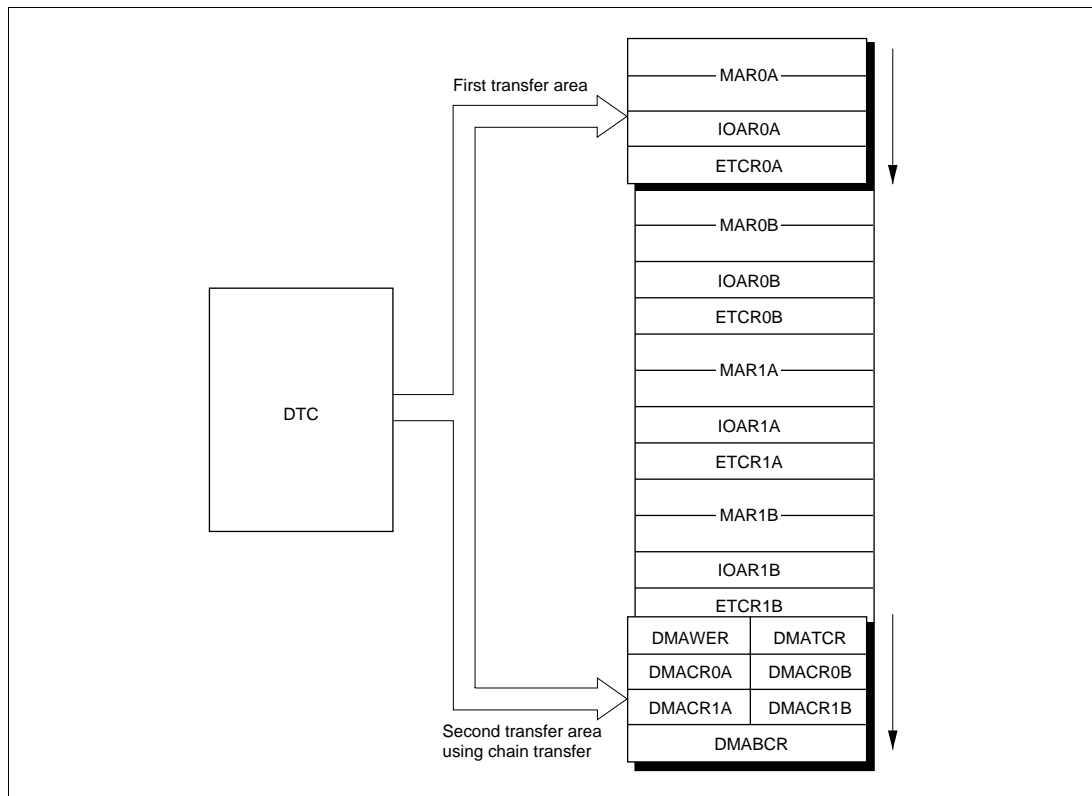
## 8.4 Register Descriptions (3)

### 8.4.1 DMA Write Enable Register (DMAWER)

The DMAC can activate the DTC with a transfer end interrupt, rewrite the channel on which the transfer ended using a DTC chain transfer, and reactivate the DTC. DMAWER applies restrictions so that only specific bits of DMACR for the specific channel and also DMATCR and DMABCR can be changed to prevent inadvertent changes being made to registers other than those for the channel concerned. The restrictions applied by DMAWER are valid for the DTC.

Figure 8-2 shows the transfer areas for activating the DTC with a channel 0A transfer end interrupt, and reactivating channel 0A. The address register and count register area is re-set by the first DTC transfer, then the control register area is re-set by the second DTC chain transfer.

When re-setting the control register area, perform masking by setting bits in DMAWER to prevent modification of the contents of the other channels.



**Figure 8-2 Areas for Register Re-Setting by DTC (Example: Channel 0A)**

Bit	:	7	6	5	4	3	2	1	0
DMAWER	:	—	—	—	—	WE1B	WE1A	WE0B	WE0A
Initial value	:	0	0	0	0	0	0	0	0
R/W	:	—	—	—	—	R/W	R/W	R/W	R/W

DMAWER is an 8-bit readable/writable register that controls enabling or disabling of writes to the DMACR, DMABCR, and DMATCR by the DTC.

DMAWER is initialized to H'00 by a reset, and in standby mode.

**Bits 7 to 4—Reserved:** These bits are always read as 0 and cannot be modified.

**Bit 3—Write Enable 1B (WE1B):** Enables or disables writes to all bits in DMACR1B, bits 11, 7, and 3 in DMABCR, and bit 5 in DMATCR by the DTC.

#### Bit 3

WE1B	Description
0	Writes to all bits in DMACR1B, bits 11, 7, and 3 in DMABCR, and bit 5 in DMATCR are disabled (Initial value)
1	Writes to all bits in DMACR1B, bits 11, 7, and 3 in DMABCR, and bit 5 in DMATCR are enabled

**Bit 2—Write Enable 1A (WE1A):** Enables or disables writes to all bits in DMACR1A, and bits 10, 6, and 2 in DMABCR by the DTC.

#### Bit 2

WE1A	Description
0	Writes to all bits in DMACR1A, and bits 10, 6, and 2 in DMABCR are disabled (Initial value)
1	Writes to all bits in DMACR1A, and bits 10, 6, and 2 in DMABCR are enabled

**Bit 1—Write Enable 0B (WE0B):** Enables or disables writes to all bits in DMACR0B, bits 9, 5, and 1 in DMABCR, and bit 4 in DMATCR.

#### Bit 1

WE0B	Description
0	Writes to all bits in DMACR0B, bits 9, 5, and 1 in DMABCR, and bit 4 in DMATCR are disabled (Initial value)
1	Writes to all bits in DMACR0B, bits 9, 5, and 1 in DMABCR, and bit 4 in DMATCR are enabled

**Bit 0—Write Enable 0A (WE0A):** Enables or disables writes to all bits in DMACR0A, and bits 8, 4, and 0 in DMABCR.

**Bit 0**

WE0A	Description
0	Writes to all bits in DMACR0A, and bits 8, 4, and 0 in DMABCR are disabled (Initial value)
1	Writes to all bits in DMACR0A, and bits 8, 4, and 0 in DMABCR are enabled

Writes by the DTC to bits 15 to 12 (FAE and SAE) in DMABCR are invalid regardless of the DMAWER settings. These bits should be changed, if necessary, by CPU processing.

In writes by the DTC to bits 7 to 4 (DTE) in DMABCR, 1 can be written without first reading 0. To reactivate a channel set to full address mode, write 1 to both Write Enable A and Write Enable B for the channel to be reactivated.

MAR, IOAR, and ETCR are always write-enabled regardless of the DMAWER settings. When modifying these registers, the channel for which the modification is to be made should be halted.

**8.4.2 DMA Terminal Control Register (DMATCR)**

Bit	:	7	6	5	4	3	2	1	0
DMATCR	:	—	—	TEE1	TEE0	—	—	—	—
Initial value	:	0	0	0	0	0	0	0	0
R/W	:	—	—	R/W	R/W	—	—	—	—

DMATCR is an 8-bit readable/writable register that controls enabling or disabling of DMAC transfer end pin output. A port can be set for output automatically, and a transfer end signal output, by setting the appropriate bit.

DMATCR is initialized to H'00 by a reset, and in standby mode.

**Bits 7 and 6—Reserved:** These bits are always read as 0 and cannot be modified.

**Bit 5—Transfer End Enable 1 (TEE1):** Enables or disables transfer end pin 1 ( $\overline{TEND1}$ ) output.

**Bit 5**

TEE1	Description
0	$\overline{TEND1}$ pin output disabled (Initial value)
1	$\overline{TEND1}$ pin output enabled

**Bit 4—Transfer End Enable 0 (TEE0):** Enables or disables transfer end pin 0 ( $\overline{\text{TEND0}}$ ) output.

**Bit 4**

TEE0	Description
0	$\overline{\text{TEND0}}$ pin output disabled (Initial value)
1	$\overline{\text{TEND0}}$ pin output enabled

The  $\overline{\text{TEND}}$  pins are assigned only to channel B in short address mode.

The transfer end signal indicates the transfer cycle in which the transfer counter reached 0, regardless of the transfer source. An exception is block transfer mode, in which the transfer end signal indicates the transfer cycle in which the block counter reached 0.

**Bits 3 to 0—Reserved:** These bits are always read as 0 and cannot be modified.

**8.4.3 Module Stop Control Register (MSTPCR)**

Bit	:	7	6	5	4	3	2	1	0
		MSTPA7	MSTPA6	MSTPA5	MSTPA4	MSTPA3	MSTPA2	MSTPA1	MSTPA0
Initial value :		0	0	1	1	1	1	1	1
R/W :		R/W	R/W	R/W	R/W	R/W	R/W	R/W	R/W

MSTPCRA is a 8-bit readable/writable register that performs module stop mode control.

When the MSTPA7 bit in MSTPCR is set to 1, the DMAC operation stops at the end of the bus cycle and a transition is made to module stop mode. For details, see section 24.5, Module Stop Mode.

MSTPCRA is initialized to H'3F by a reset and in hardware standby mode. It is not initialized by a manual reset and in software standby mode.

**Bit 7—Module Stop (MSTP7):** Specifies the DMAC module stop mode.

**Bits 7**

MSTPA7	Description
0	DMAC module stop mode cleared (Initial value)
1	DMAC module stop mode set

## 8.5 Operation

### 8.5.1 Transfer Modes

Table 8-5 lists the DMAC modes.

**Table 8-5 DMAC Transfer Modes**

Transfer Mode		Transfer Source	Remarks
Short address mode	Dual address mode	(1) Sequential mode	<ul style="list-style-type: none"> <li>Up to 4 channels can operate independently</li> <li>External request applies to channel B only</li> <li>Single address mode applies to channel B only</li> <li>Modes (1), (2), and (3) can also be specified for single address mode</li> </ul>
		(2) Idle mode	
		(3) Repeat mode	
	(4) Single address mode		
Full address mode		(5) Normal mode	<ul style="list-style-type: none"> <li>Max. 2-channel operation, combining channels A and B</li> <li>With auto-request, burst mode transfer or cycle steal transfer can be selected</li> </ul>
		(6) Block transfer mode	



Operation in each mode is summarized below.

**(1) Sequential mode**

In response to a single transfer request, the specified number of transfers are carried out, one byte or one word at a time. An interrupt request can be sent to the CPU or DTC when the specified number of transfers have been completed. One address is specified as 24 bits, and the other as 16 bits. The transfer direction is programmable.

**(2) Idle mode**

In response to a single transfer request, the specified number of transfers are carried out, one byte or one word at a time. An interrupt request can be sent to the CPU or DTC when the specified number of transfers have been completed. One address is specified as 24 bits, and the other as 16 bits. The transfer source address and transfer destination address are fixed. The transfer direction is programmable.

**(3) Repeat mode**

In response to a single transfer request, the specified number of transfers are carried out, one byte or one word at a time. When the specified number of transfers have been completed, the addresses and transfer counter are restored to their original settings, and operation is continued. No interrupt request is sent to the CPU or DTC. One address is specified as 24 bits, and the other as 16 bits. The transfer direction is programmable.

**(4) Single address mode**

In response to a single transfer request, the specified number of transfers are carried out between external memory and an external device, one byte or one word at a time. Unlike dual address mode, source and destination accesses are performed in parallel. Therefore, either the source or the destination is an external device which can be accessed with a strobe alone, using the  $\overline{\text{DACK}}$  pin. One address is specified as 24 bits, and for the other, the pin is set automatically. The transfer direction is programmable.

Modes (1), (2) and (3) can also be specified for single address mode.

**(5) Normal mode**

- Auto-request

By means of register settings only, the DMAC is activated, and transfer continues until the specified number of transfers have been completed. An interrupt request can be sent to the CPU or DTC when transfer is completed. Both addresses are specified as 24 bits.

— Cycle steal mode: The bus is released to another bus master every byte or word transfer.

— Burst mode: The bus is held and transfer continued until the specified number of transfers have been completed.

- External request  
In response to a single transfer request, the specified number of transfers are carried out, one byte or one word at a time. An interrupt request can be sent to the CPU or DTC when the specified number of transfers have been completed. Both addresses are specified as 24 bits.

**(6) Block transfer mode**

In response to a single transfer request, a block transfer of the specified block size is carried out. This is repeated the specified number of times, once each time there is a transfer request. At the end of each single block transfer, one address is restored to its original setting. An interrupt request can be sent to the CPU or DTC when the specified number of block transfers have been completed. Both addresses are specified as 24 bits.

**8.5.2 Sequential Mode**

Sequential mode can be specified by clearing the RPE bit in DMACR to 0. In sequential mode, MAR is updated after each byte or word transfer in response to a single transfer request, and this is executed the number of times specified in ETCR.

One address is specified by MAR, and the other by IOAR. The transfer direction can be specified by the DTDIR bit in DMACR.

Table 8-6 summarizes register functions in sequential mode.

**Table 8-6 Register Functions in Sequential Mode**

Register	Function		Initial Setting	Operation
	DTDIR = 0	DTDIR = 1		
<div style="display: flex; justify-content: space-between;"> <span>23</span> <span>0</span> </div> <div style="border: 1px solid black; padding: 5px; margin: 5px 0;"> <div style="display: flex; justify-content: space-between;"> <span style="width: 10%;"></span> <span style="width: 80%; text-align: center;">MAR</span> <span style="width: 10%;"></span> </div> </div>	Source address register	Destination address register	Start address of transfer destination or transfer source	Incremented/decrypted every transfer
<div style="display: flex; justify-content: space-between;"> <span>23</span> <span>15</span> <span>0</span> </div> <div style="border: 1px solid black; padding: 5px; margin: 5px 0;"> <div style="display: flex; justify-content: space-between;"> <span style="width: 15%; text-align: center;">H'FF</span> <span style="width: 70%; text-align: center;">IOAR</span> </div> </div>	Destination address register	Source address register	Start address of transfer source or transfer destination	Fixed
<div style="display: flex; justify-content: space-between;"> <span>15</span> <span>0</span> </div> <div style="border: 1px solid black; padding: 5px; margin: 5px 0;"> <div style="display: flex; justify-content: space-between;"> <span style="width: 100%; text-align: center;">ETCR</span> </div> </div>	Transfer counter		Number of transfers	Decrypted every transfer; transfer ends when count reaches H'0000

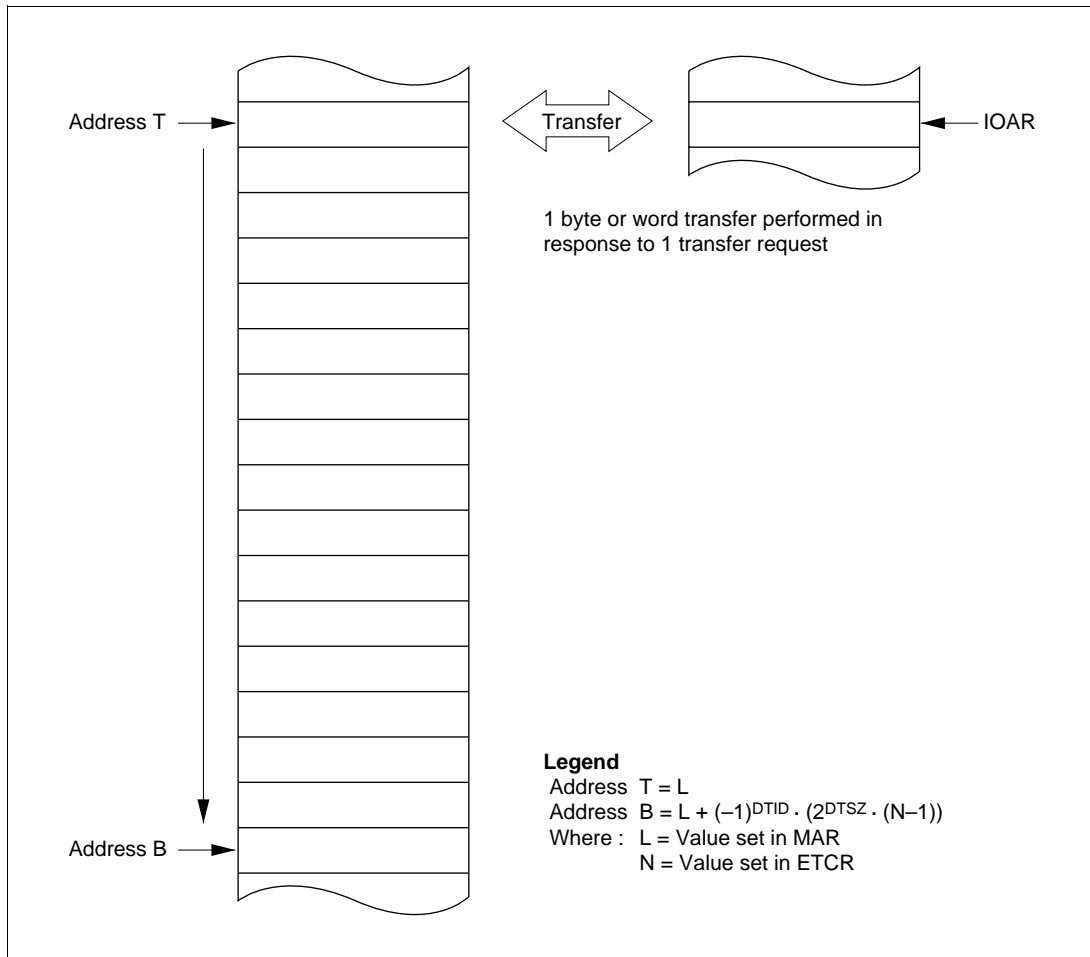
**Legend**

- MAR : Memory address register
- IOAR : I/O address register
- ETCR : Transfer count register
- DTDIR : Data transfer direction bit

MAR specifies the start address of the transfer source or transfer destination as 24 bits. MAR is incremented or decremented by 1 or 2 each time a byte or word is transferred.

IOAR specifies the lower 16 bits of the other address. The 8 bits above IOAR have a value of H'FF.

Figure 8-3 illustrates operation in sequential mode.



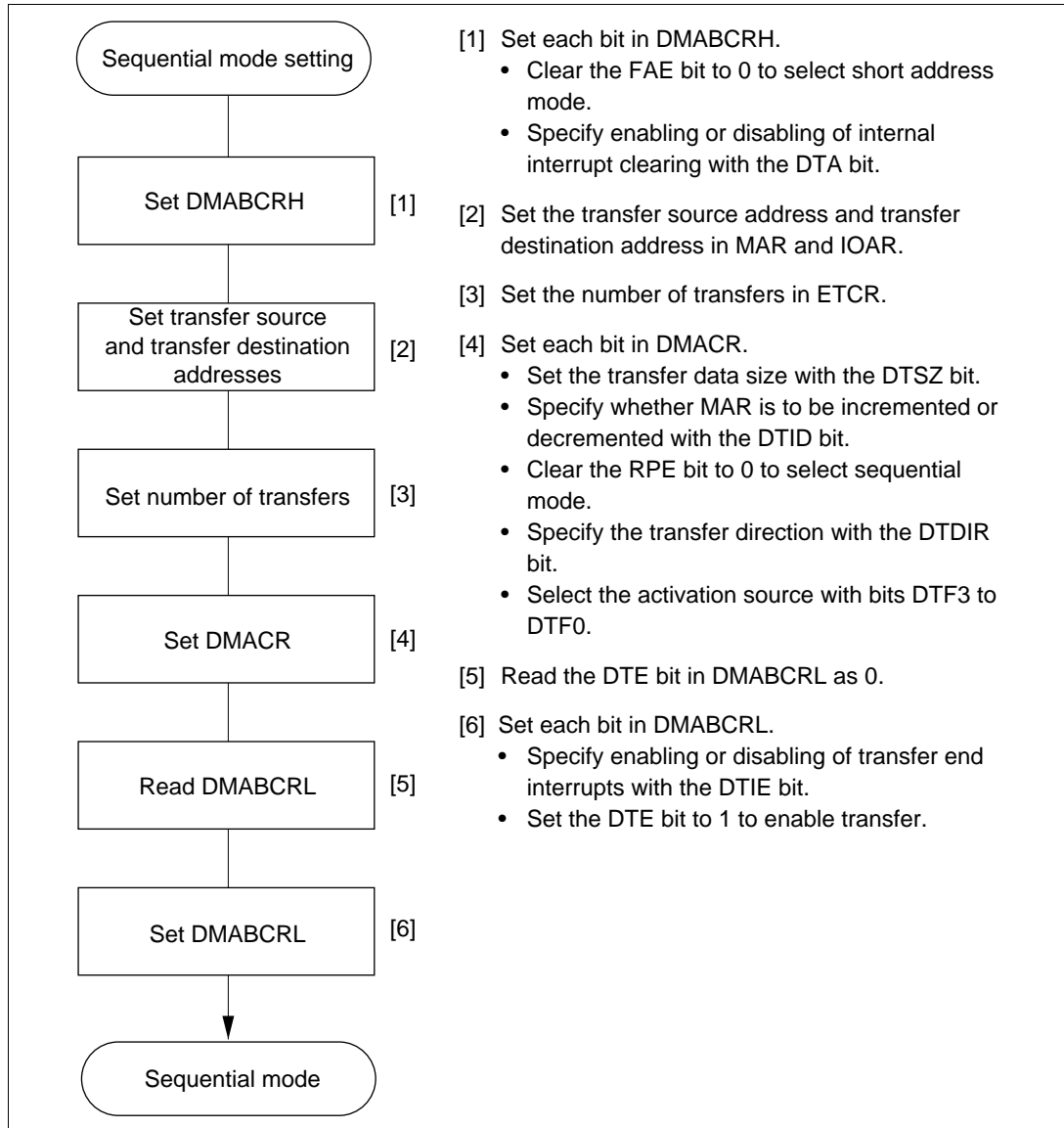
**Figure 8-3 Operation in Sequential Mode**

The number of transfers is specified as 16 bits in ETCR. ETCR is decremented by 1 each time a transfer is executed, and when its value reaches H'0000, the DTE bit is cleared and transfer ends. If the DTIE bit is set to 1 at this time, an interrupt request is sent to the CPU or DTC.

The maximum number of transfers, when H'0000 is set in ETCR, is 65,536.

Transfer requests (activation sources) consist of A/D converter conversion end interrupts, external requests, SCI transmission complete and reception complete interrupts, and TPU channels 0 to 5 compare match/input capture A interrupts. External requests can be set for channel B only.

Figure 8-4 shows an example of the setting procedure for sequential mode.



**Figure 8-4 Example of Sequential Mode Setting Procedure**

### 8.5.3 Idle Mode

Idle mode can be specified by setting the RPE bit and DTIE bit in DMACR to 1. In idle mode, one byte or word is transferred in response to a single transfer request, and this is executed the number of times specified in ETCR.

One address is specified by MAR, and the other by IOAR. The transfer direction can be specified by the DTDIR bit in DMACR.

Table 8-7 summarizes register functions in idle mode.

**Table 8-7 Register Functions in Idle Mode**

Register	Function		Initial Setting	Operation
	DTDIR = 0	DTDIR = 1		
<div style="display: flex; justify-content: space-between;"> <span>23</span> <span>0</span> </div> <div style="border: 1px solid black; padding: 2px; margin: 5px 0;"> <span style="float: left;">23</span> <span style="float: right;">0</span> <div style="text-align: center; border: 1px dashed black; padding: 2px;">MAR</div> </div>	Source address register	Destination address register	Start address of transfer destination or transfer source	Fixed
<div style="display: flex; justify-content: space-between;"> <span>23</span> <span>15</span> <span>0</span> </div> <div style="border: 1px solid black; padding: 2px; margin: 5px 0;"> <span style="float: left;">23</span> <span style="float: right;">15</span> <div style="text-align: center; border: 1px dashed black; padding: 2px;">H'FF</div> <div style="text-align: center; border: 1px dashed black; padding: 2px;">IOAR</div> </div>	Destination address register	Source address register	Start address of transfer source or transfer destination	Fixed
<div style="display: flex; justify-content: space-between;"> <span>15</span> <span>0</span> </div> <div style="border: 1px solid black; padding: 2px; margin: 5px 0;"> <span style="float: left;">15</span> <span style="float: right;">0</span> <div style="text-align: center; border: 1px dashed black; padding: 2px;">ETCR</div> </div>	Transfer counter		Number of transfers	Decrement every transfer; transfer ends when count reaches H'0000

#### Legend

MAR : Memory address register

IOAR : I/O address register

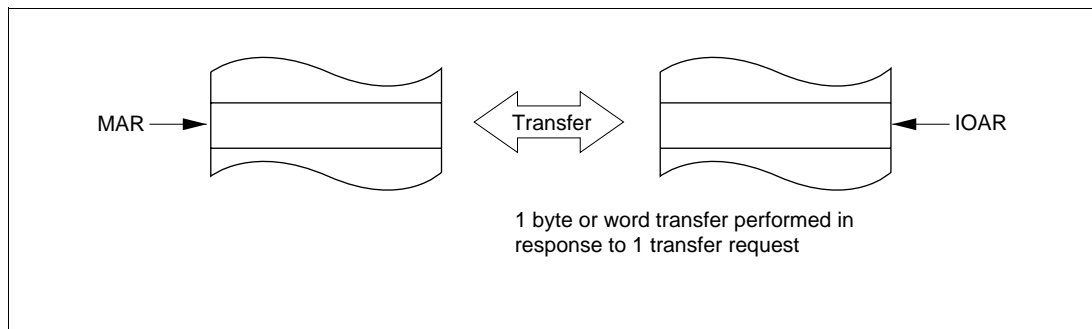
ETCR : Transfer count register

DTDIR : Data transfer direction bit

MAR specifies the start address of the transfer source or transfer destination as 24 bits. MAR is neither incremented nor decremented each time a byte or word is transferred.

IOAR specifies the lower 16 bits of the other address. The 8 bits above IOAR have a value of H'FF.

Figure 8-5 illustrates operation in idle mode.



**Figure 8-5 Operation in Idle Mode**

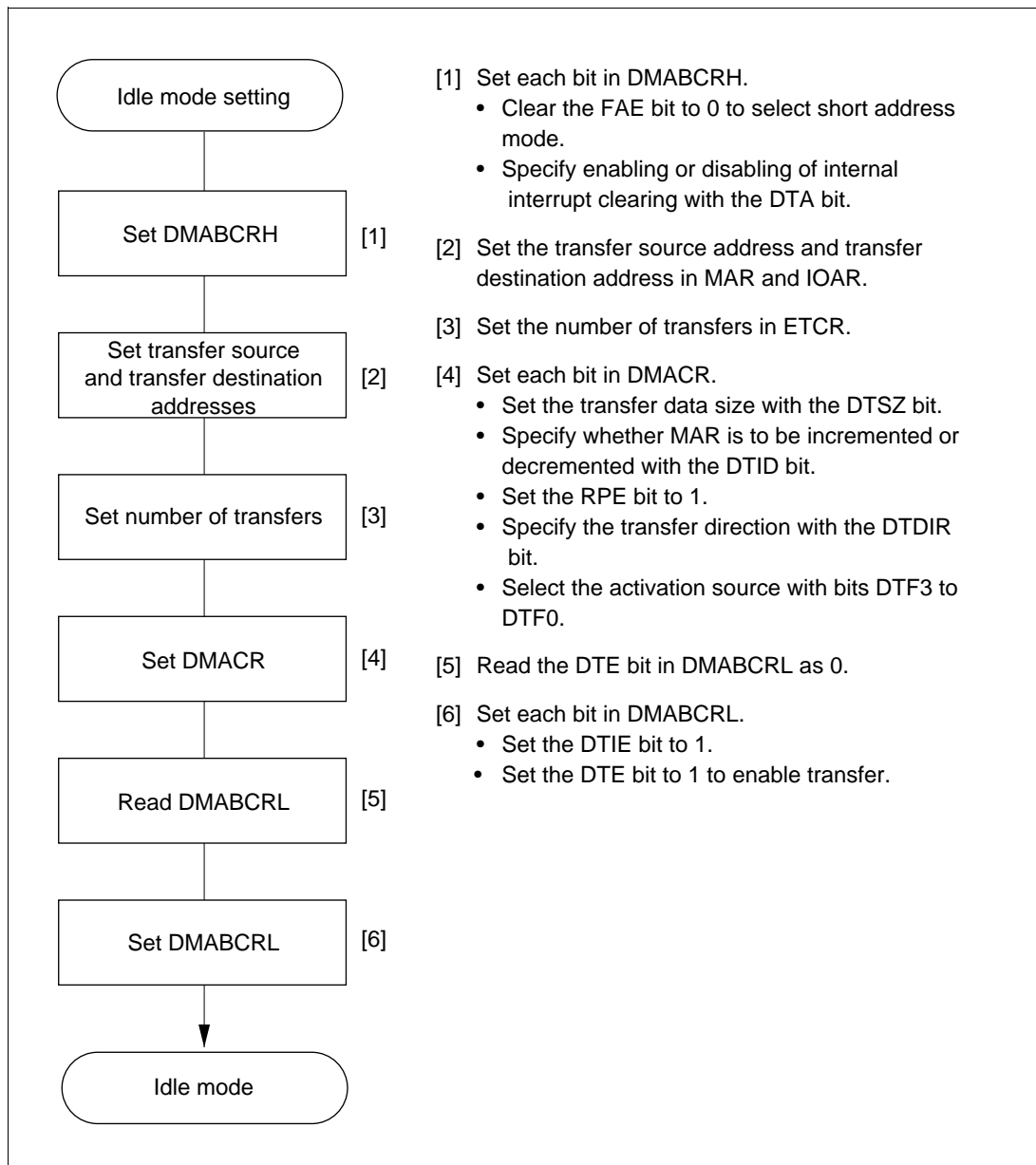
The number of transfers is specified as 16 bits in ETCR. ETCR is decremented by 1 each time a transfer is executed, and when its value reaches H'0000, the DTE bit is cleared and transfer ends. If the DTIE bit is set to 1 at this time, an interrupt request is sent to the CPU or DTC.

The maximum number of transfers, when H'0000 is set in ETCR, is 65,536.

Transfer requests (activation sources) consist of A/D converter conversion end interrupts, external requests, SCI transmission complete and reception complete interrupts, and TPU channels 0 to 5 compare match/input capture A interrupts. External requests can be set for channel B only.

When the DMAC is used in single address mode, only channel B can be set.

Figure 8-6 shows an example of the setting procedure for idle mode.



**Figure 8-6 Example of Idle Mode Setting Procedure**

### 8.5.4 Repeat Mode

Repeat mode can be specified by setting the RPE bit in DMACR to 1, and clearing the DTIE bit to 0. In repeat mode, MAR is updated after each byte or word transfer in response to a single transfer request, and this is executed the number of times specified in ETCR. On completion of the specified number of transfers, MAR and ETCRL are automatically restored to their original settings and operation continues.

One address is specified by MAR, and the other by IOAR. The transfer direction can be specified by the DTDIR bit in DMACR.

Table 8-8 summarizes register functions in repeat mode.

**Table 8-8 Register Functions in Repeat Mode**

Register	Function		Initial Setting	Operation
	DTDIR = 0	DTDIR = 1		
<div style="display: flex; align-items: center;"> <span style="margin-right: 10px;">23</span> <div style="border: 1px solid black; padding: 2px; text-align: center; width: 100px;"> <span style="font-size: small;">23</span>  <span style="font-size: x-small;">MAR</span>  <span style="font-size: small;">0</span> </div> </div>	Source address register	Destination address register	Start address of transfer destination or transfer source	Incremented/decrypted every transfer. Initial setting is restored when value reaches H'0000
<div style="display: flex; align-items: center;"> <span style="margin-right: 10px;">23</span> <div style="border: 1px solid black; padding: 2px; text-align: center; width: 100px;"> <span style="font-size: x-small;">H'FF</span> <span style="font-size: x-small;">IOAR</span> </div> </div>	Destination address register	Source address register	Start address of transfer source or transfer destination	Fixed
<div style="display: flex; align-items: center;"> <span style="margin-right: 10px;">7</span> <div style="border: 1px solid black; padding: 2px; text-align: center; width: 50px;"> <span style="font-size: x-small;">ETCRH</span> </div> </div>	Holds number of transfers		Number of transfers	Fixed
-----				
<div style="display: flex; align-items: center;"> <span style="margin-right: 10px;">7</span> <div style="border: 1px solid black; padding: 2px; text-align: center; width: 50px;"> <span style="font-size: x-small;">ETCRL</span> </div> </div>	Transfer counter		Number of transfers	Decrypted every transfer. Loaded with ETCRH value when count reaches H'00

**Legend**

- MAR : Memory address register
- IOAR : I/O address register
- ETCR : Transfer count register
- DTDIR : Data transfer direction bit



MAR specifies the start address of the transfer source or transfer destination as 24 bits. MAR is incremented or decremented by 1 or 2 each time a byte or word is transferred.

IOAR specifies the lower 16 bits of the other address. The 8 bits above IOAR have a value of H'FF.

The number of transfers is specified as 8 bits by ETCRH and ETCRL. The maximum number of transfers, when H'00 is set in both ETCRH and ETCRL, is 256.

In repeat mode, ETCRL functions as the transfer counter, and ETCRH is used to hold the number of transfers. ETCRL is decremented by 1 each time a transfer is executed, and when its value reaches H'00, it is loaded with the value in ETCRH. At the same time, the value set in MAR is restored in accordance with the values of the DTSZ and DTID bits in DMACR. The MAR restoration operation is as shown below.

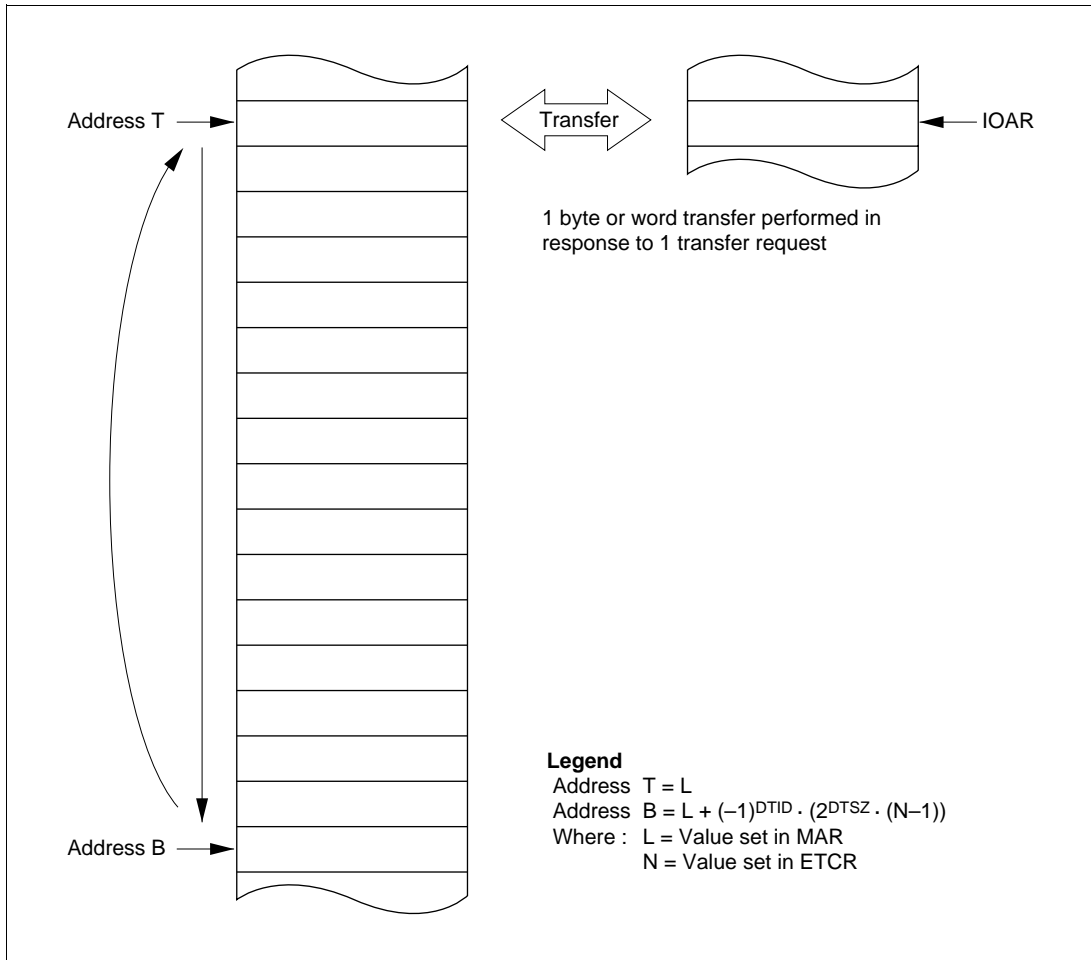
$$\text{MAR} = \text{MAR} - (-1)^{\text{DTID}} \cdot 2^{\text{DTSZ}} \cdot \text{ETCRH}$$

The same value should be set in ETCRH and ETCRL.

In repeat mode, operation continues until the DTE bit is cleared. To end the transfer operation, therefore, you should clear the DTE bit to 0. A transfer end interrupt request is not sent to the CPU or DTC.

By setting the DTE bit to 1 again after it has been cleared, the operation can be restarted from the transfer after that terminated when the DTE bit was cleared.

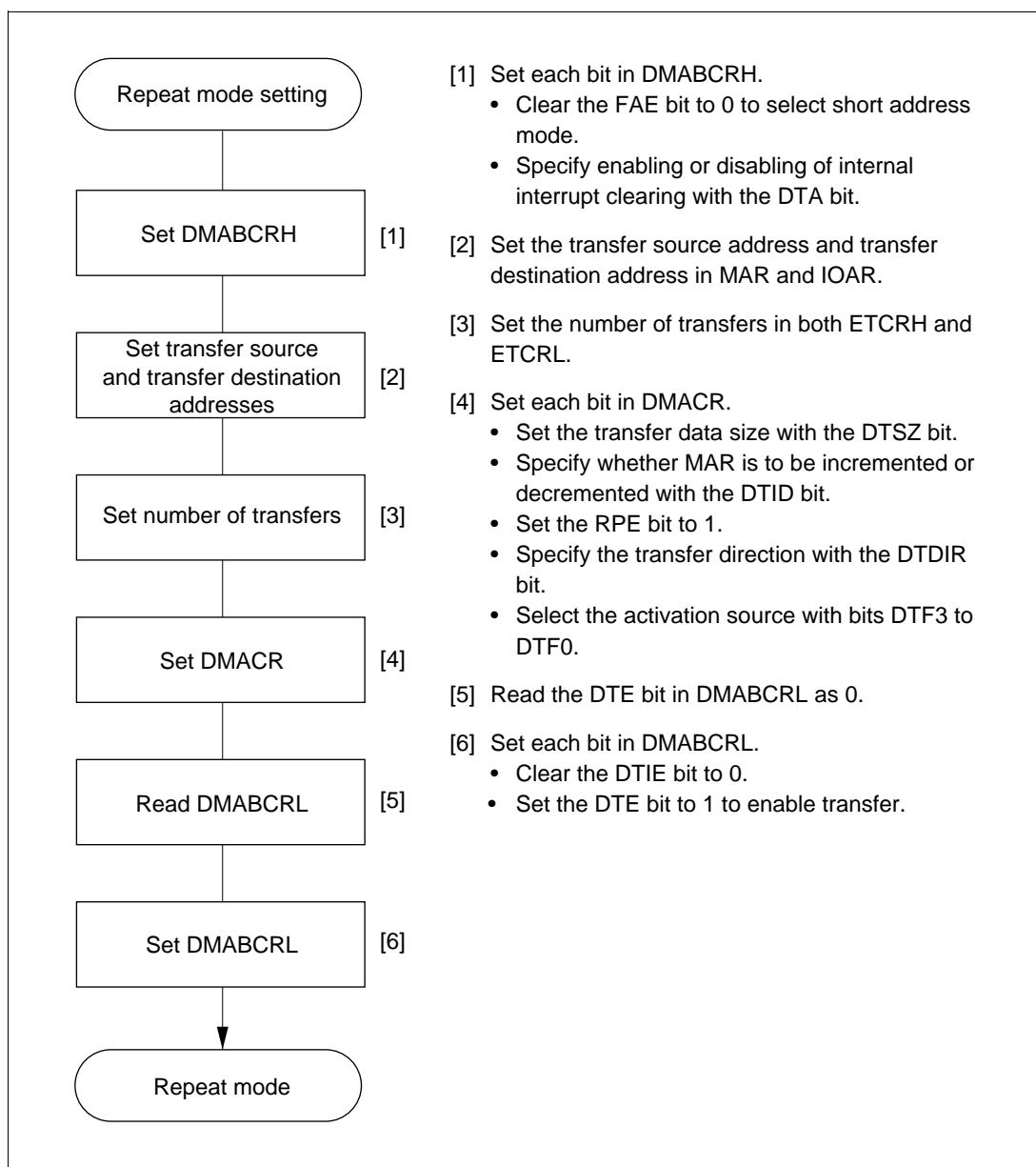
Figure 8-7 illustrates operation in repeat mode.



**Figure 8-7 Operation in Repeat mode**

Transfer requests (activation sources) consist of A/D converter conversion end interrupts, external requests, SCI transmission complete and reception complete interrupts, and TPU channels 0 to 5 compare match/input capture A interrupts. External requests can be set for channel B only.

Figure 8-8 shows an example of the setting procedure for repeat mode.



**Figure 8-8 Example of Repeat Mode Setting Procedure**

### 8.5.5 Single Address Mode

Single address mode can only be specified for channel B. This mode can be specified by setting the SAE bit in DMABCR to 1 in short address mode.

One address is specified by MAR, and the other is set automatically to the data transfer acknowledge pin ( $\overline{\text{DACK}}$ ). The transfer direction can be specified by the DTDIR in DMACR.

Table 8-9 summarizes register functions in single address mode.

**Table 8-9 Register Functions in Single Address Mode**

Register	Function		Initial Setting	Operation
	DTDIR = 0	DTDIR = 1		
<div style="display: flex; align-items: center;"> <span style="margin-right: 10px;">23</span> <div style="border: 1px solid black; padding: 2px; display: flex; align-items: center; justify-content: center; width: 100px;"> <span style="margin-right: 5px;">0</span> <span style="margin-right: 5px;">MAR</span> <span style="margin-left: 5px;">0</span> </div> </div>	Source address register	Destination address register	Start address of transfer destination or transfer source	*
$\overline{\text{DACK}}$ pin	Write strobe	Read strobe	(Set automatically by SAE bit; IOAR is invalid)	Strobe for external device
<div style="display: flex; align-items: center;"> <span style="margin-right: 10px;">15</span> <div style="border: 1px solid black; padding: 2px; display: flex; align-items: center; justify-content: center; width: 100px;"> <span style="margin-right: 5px;">0</span> <span style="margin-right: 5px;">ETCR</span> <span style="margin-left: 5px;">0</span> </div> </div>	Transfer counter		Number of transfers	*

#### Legend

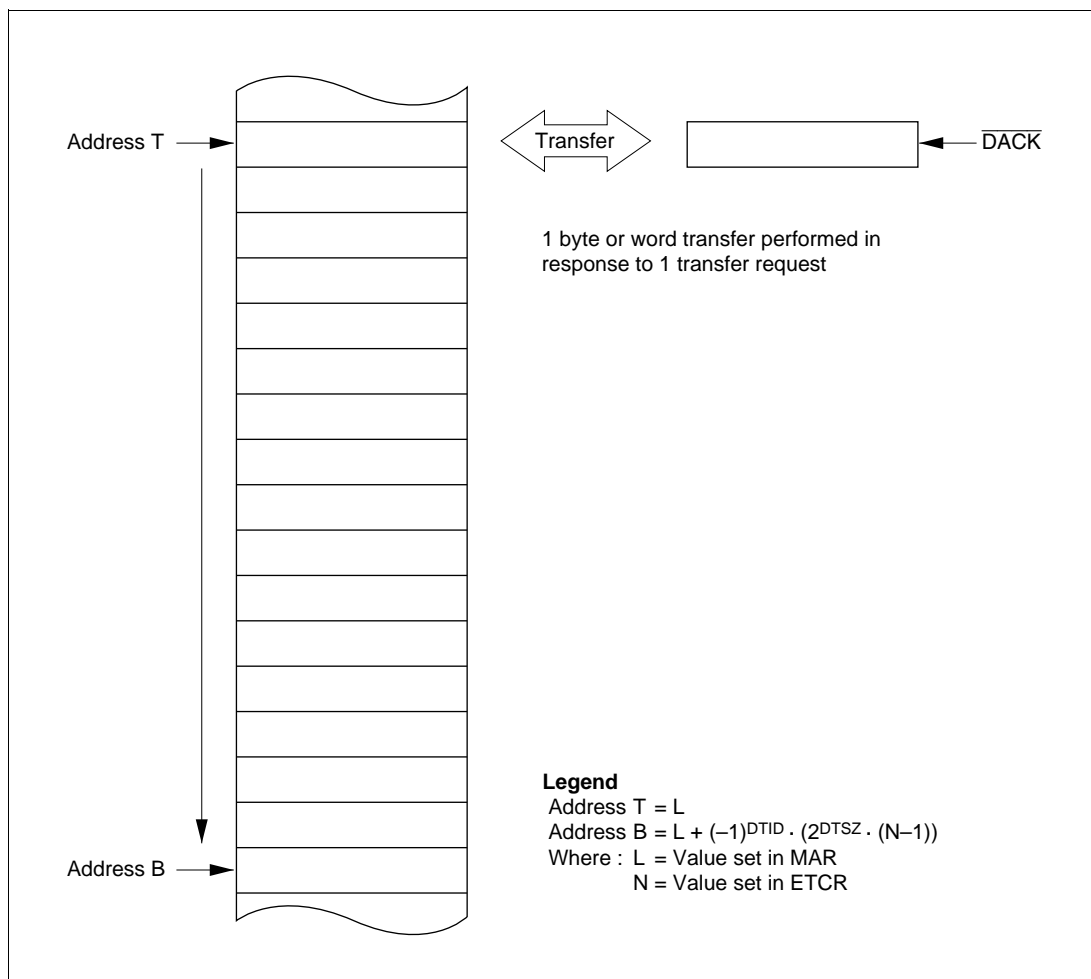
- MAR : Memory address register
- IOAR : I/O address register
- ETCR : Transfer count register
- DTDIR : Data transfer direction bit
- $\overline{\text{DACK}}$  : Data transfer acknowledge

Note: \* See the operation descriptions in sections 8.5.2, Sequential Mode, 8.5.3, Idle Mode, and 8.5.4, Repeat Mode.

MAR specifies the start address of the transfer source or transfer destination as 24 bits.

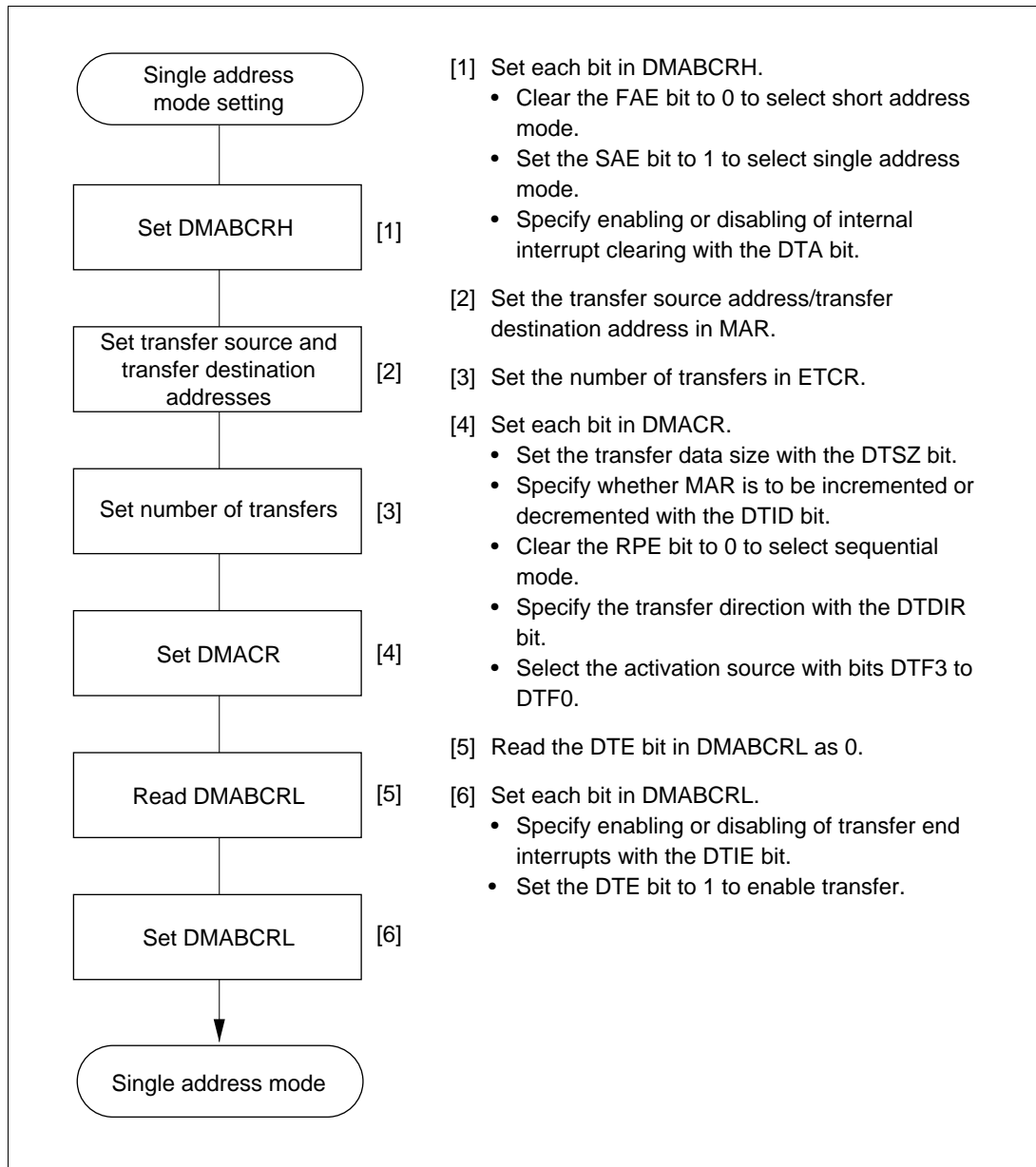
IOAR is invalid; in its place the strobe for external devices ( $\overline{\text{DACK}}$ ) is output.

Figure 8-9 illustrates operation in single address mode (when sequential mode is specified).



**Figure 8-9 Operation in Single Address Mode (When Sequential Mode is Specified)**

Figure 8-10 shows an example of the setting procedure for single address mode (when sequential mode is specified).



**Figure 8-10 Example of Single Address Mode Setting Procedure (When Sequential Mode is Specified)**

### 8.5.6 Normal Mode

In normal mode, transfer is performed with channels A and B used in combination. Normal mode can be specified by setting the FAE bit in DMABCR to 1 and clearing the BLKE bit in DMACRA to 0.

In normal mode, MAR is updated after each byte or word transfer in response to a single transfer request, and this is executed the number of times specified in ETCRA. The transfer source is specified by MARA, and the transfer destination by MARB.

Table 8-10 summarizes register functions in normal mode.

**Table 8-10 Register Functions in Normal Mode**

Register	Function	Initial Setting	Operation
<div style="display: flex; align-items: center;"> <span style="margin-right: 10px;">23</span> <div style="border: 1px solid black; padding: 2px; display: flex; align-items: center; justify-content: center; width: 100px;"> <span style="margin: 0 5px;"> </span> <span style="margin: 0 5px;">MARA</span> <span style="margin: 0 5px;"> </span> </div> <span style="margin-left: 10px;">0</span> </div>	Source address register	Start address of transfer source	Incremented/decremented every transfer, or fixed
<div style="display: flex; align-items: center;"> <span style="margin-right: 10px;">23</span> <div style="border: 1px solid black; padding: 2px; display: flex; align-items: center; justify-content: center; width: 100px;"> <span style="margin: 0 5px;"> </span> <span style="margin: 0 5px;">MARB</span> <span style="margin: 0 5px;"> </span> </div> <span style="margin-left: 10px;">0</span> </div>	Destination address register	Start address of transfer destination	Incremented/decremented every transfer, or fixed
<div style="display: flex; align-items: center;"> <span style="margin-right: 10px;">15</span> <div style="border: 1px solid black; padding: 2px; display: flex; align-items: center; justify-content: center; width: 100px;"> <span style="margin: 0 5px;"> </span> <span style="margin: 0 5px;">ETCRA</span> <span style="margin: 0 5px;"> </span> </div> <span style="margin-left: 10px;">0</span> </div>	Transfer counter	Number of transfers	Decremented every transfer; transfer ends when count reaches H'0000

#### Legend

MARA : Memory address register A

MARB : Memory address register B

ETCRA : Transfer count register A

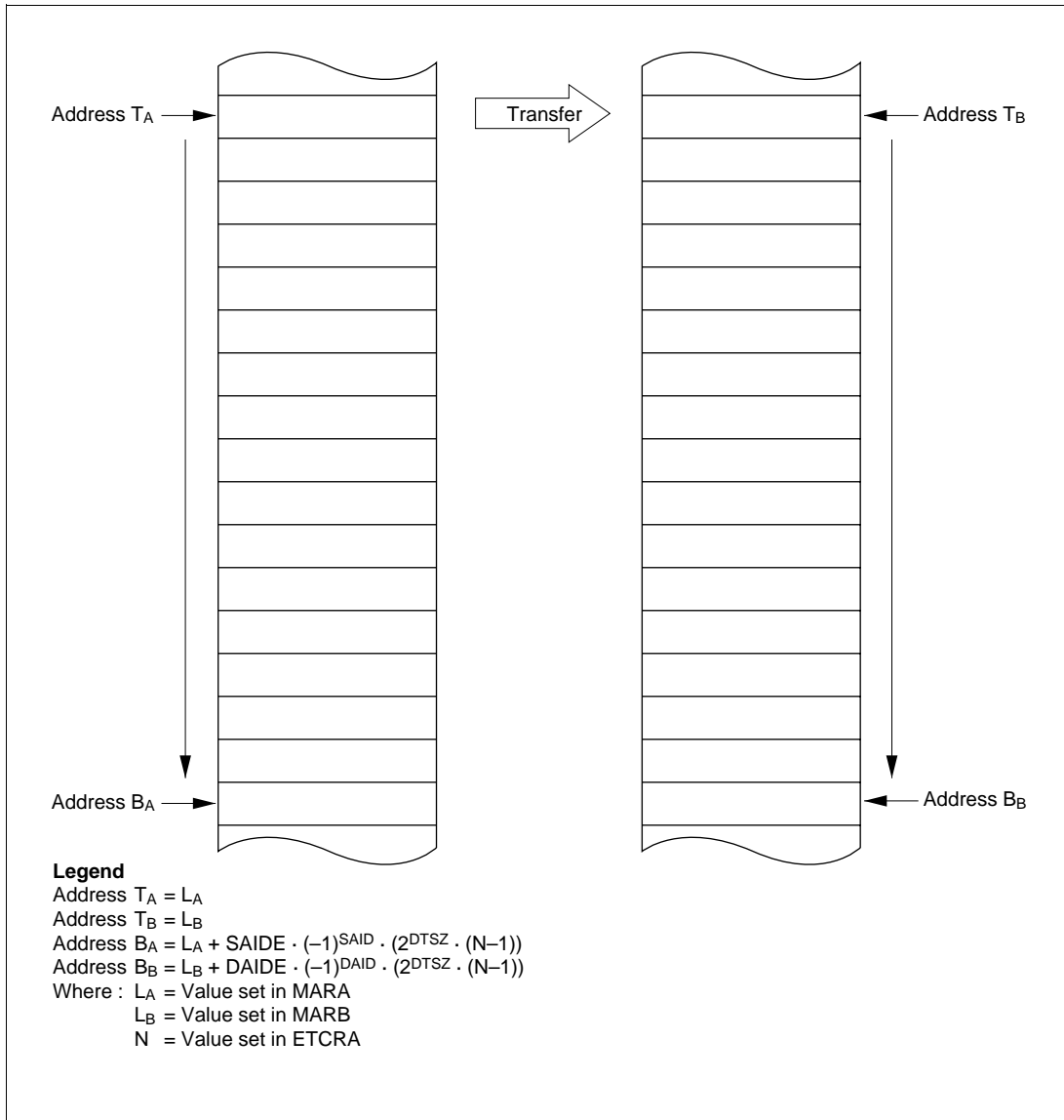
MARA and MARB specify the start addresses of the transfer source and transfer destination, respectively, as 24 bits. MAR can be incremented or decremented by 1 or 2 each time a byte or word is transferred, or can be fixed.

Incrementing, decrementing, or holding a fixed value can be set separately for MARA and MARB.

The number of transfers is specified by ETCRA as 16 bits. ETCRA is decremented each time a transfer is performed, and when its value reaches H'0000 the DTE bit is cleared and transfer ends. If the DTIE bit is set to 1 at this time, an interrupt request is sent to the CPU or DTC.

The maximum number of transfers, when H'0000 is set in ETCRA, is 65,536.

Figure 8-11 illustrates operation in normal mode.



**Figure 8-11 Operation in Normal Mode**

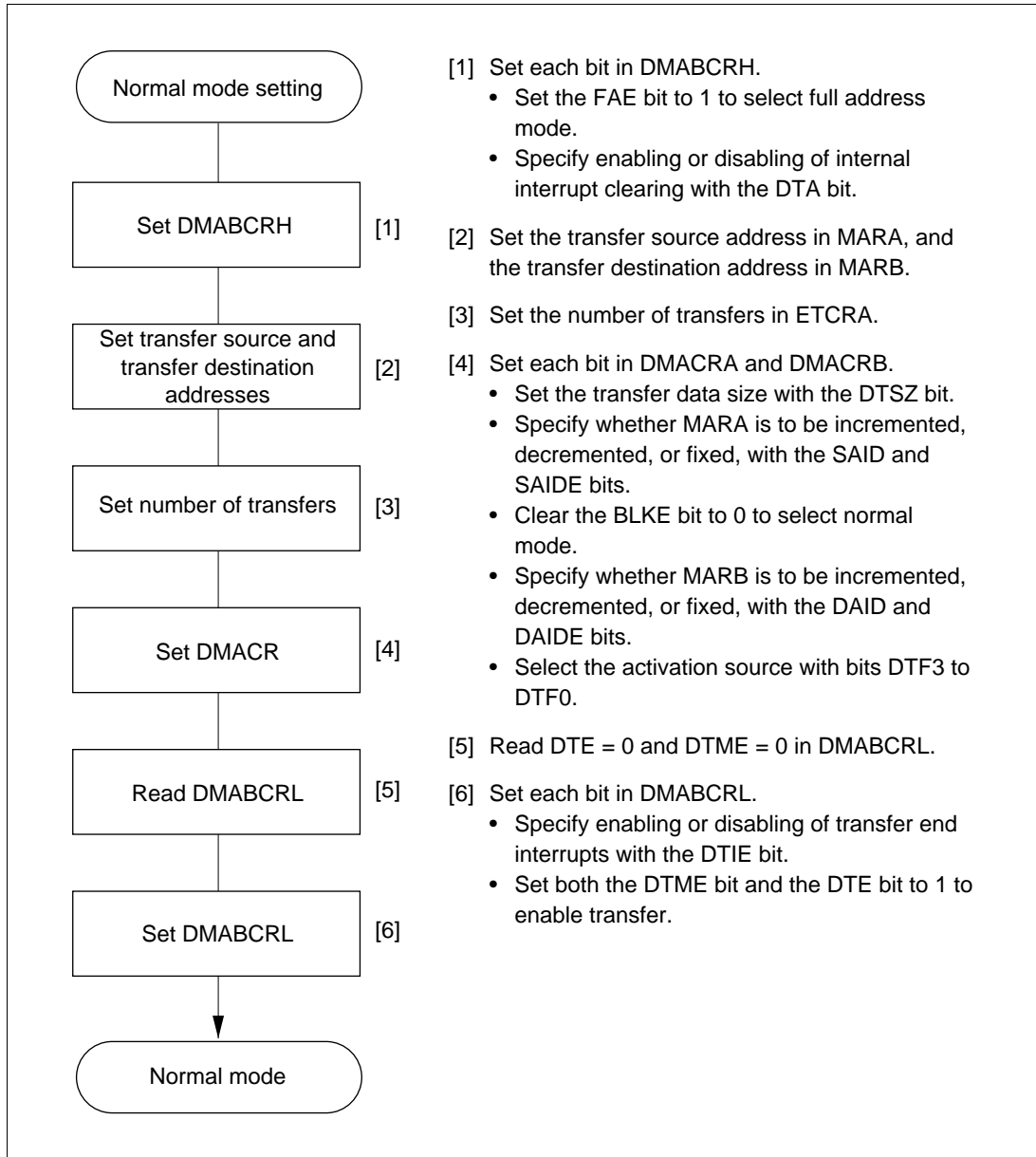
Transfer requests (activation sources) are external requests and auto-requests.

With auto-request, the DMAC is only activated by register setting, and the specified number of transfers are performed automatically. With auto-request, cycle steal mode or burst mode can be selected. In cycle steal mode, the bus is released to another bus master each time a transfer is performed. In burst mode, the bus is held continuously until transfer ends.



For setting details, see section 8.3.4, DMA Controller Register (DMACR).

Figure 8-12 shows an example of the setting procedure for normal mode.



**Figure 8-12 Example of Normal Mode Setting Procedure**

### 8.5.7 Block Transfer Mode

In block transfer mode, transfer is performed with channels A and B used in combination. Block transfer mode can be specified by setting the FAE bit in DMABCR and the BLKE bit in DMACRA to 1.

In block transfer mode, a transfer of the specified block size is carried out in response to a single transfer request, and this is executed the specified number of times. The transfer source is specified by MARA, and the transfer destination by MARB. Either the transfer source or the transfer destination can be selected as a block area (an area composed of a number of bytes or words).

Table 8-11 summarizes register functions in block transfer mode.

**Table 8-11 Register Functions in Block Transfer Mode**

Register	Function	Initial Setting	Operation
<div style="display: flex; justify-content: space-between;"> <span>23</span> <span>0</span> </div> <div style="border: 1px solid black; padding: 2px; text-align: center; margin: 2px 0;">MARA</div>	Source address register	Start address of transfer source	Incremented/decremented every transfer, or fixed
<div style="display: flex; justify-content: space-between;"> <span>23</span> <span>0</span> </div> <div style="border: 1px solid black; padding: 2px; text-align: center; margin: 2px 0;">MARB</div>	Destination address register	Start address of transfer destination	Incremented/decremented every transfer, or fixed
<div style="display: flex; justify-content: space-between;"> <span>7</span> <span>0</span> </div> <div style="border: 1px solid black; padding: 2px; text-align: center; margin: 2px 0;">ETCRAH</div>	Holds block size	Block size	Fixed
<div style="display: flex; justify-content: space-between;"> <span>7</span> <span>0</span> </div> <div style="border: 1px solid black; padding: 2px; text-align: center; margin: 2px 0;">ETCRAL</div>	Block size counter	Block size	Decrement every transfer; ETCRH value copied when count reaches H'00
<div style="display: flex; justify-content: space-between;"> <span>15</span> <span>0</span> </div> <div style="border: 1px solid black; padding: 2px; text-align: center; margin: 2px 0;">ETCRB</div>	Block transfer counter	Number of block transfers	Decrement every block transfer; transfer ends when count reaches H'0000

#### Legend

MARA : Memory address register A  
MARB : Memory address register B  
ETCRA : Transfer count register A  
ETCRB : Transfer count register B

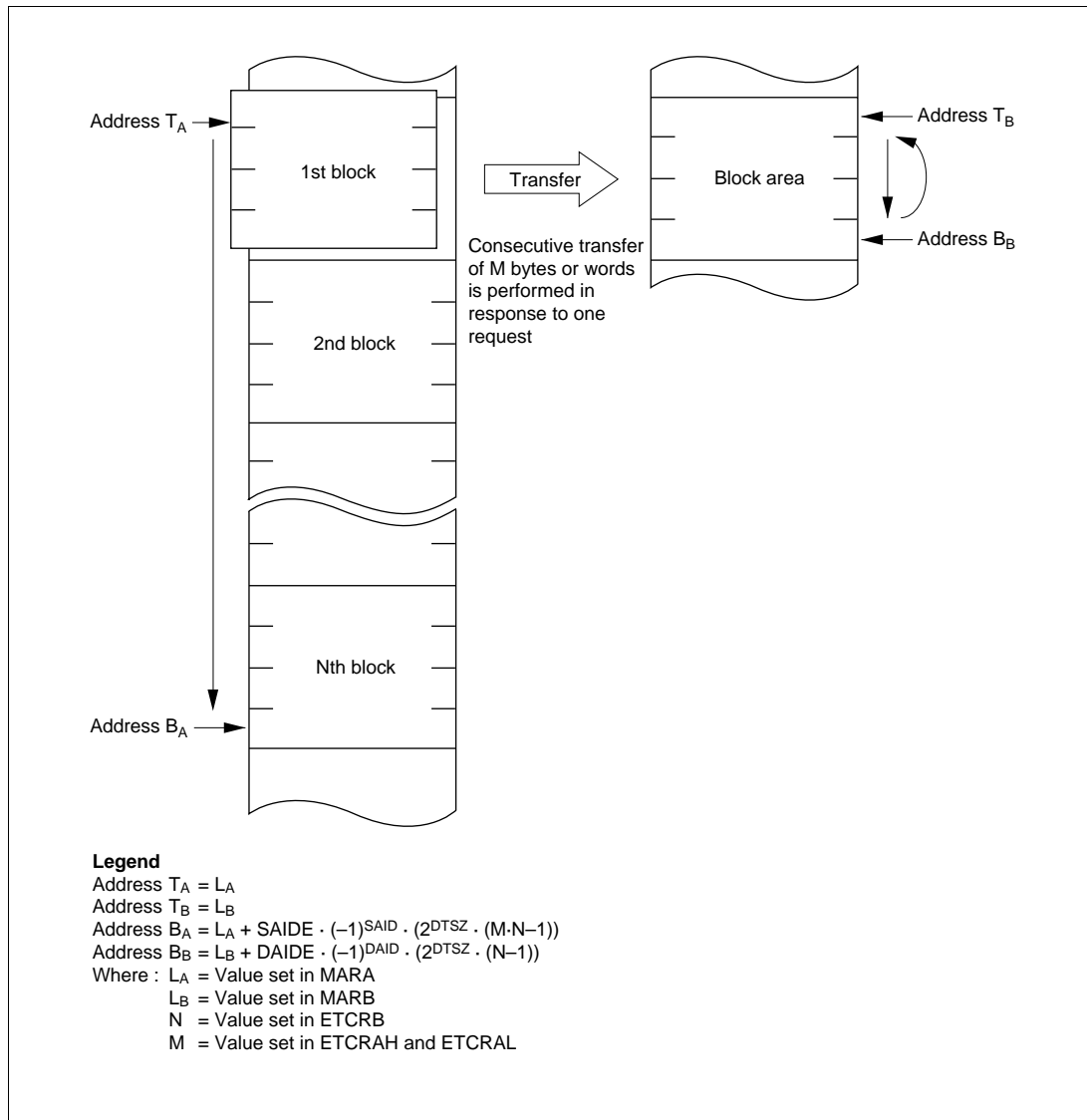
MARA and MARB specify the start addresses of the transfer source and transfer destination, respectively, as 24 bits. MAR can be incremented or decremented by 1 or 2 each time a byte or word is transferred, or can be fixed.

Incrementing, decrementing, or holding a fixed value can be set separately for MARA and MARB.

Whether a block is to be designated for MARA or for MARB is specified by the BLKDIR bit in DMACRA.

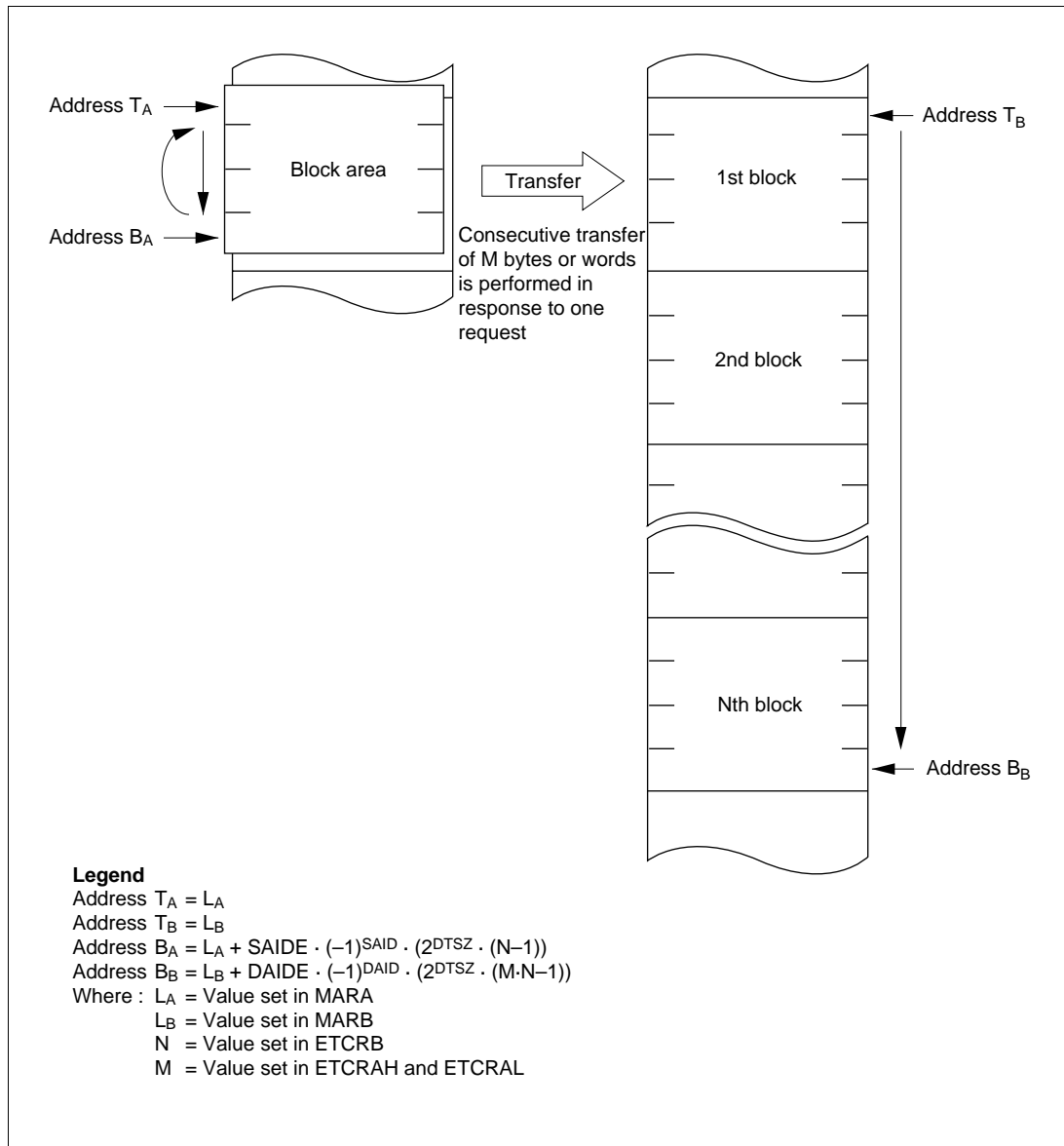
To specify the number of transfers, if M is the size of one block (where M = 1 to 256) and N transfers are to be performed (where N = 1 to 65,536), M is set in both ETCRAH and ETCRAL, and N in ETCRB.

Figure 8-13 illustrates operation in block transfer mode when MARB is designated as a block area.



**Figure 8-13 Operation in Block Transfer Mode (BLKDIR = 0)**

Figure 8-14 illustrates operation in block transfer mode when MARA is designated as a block area.

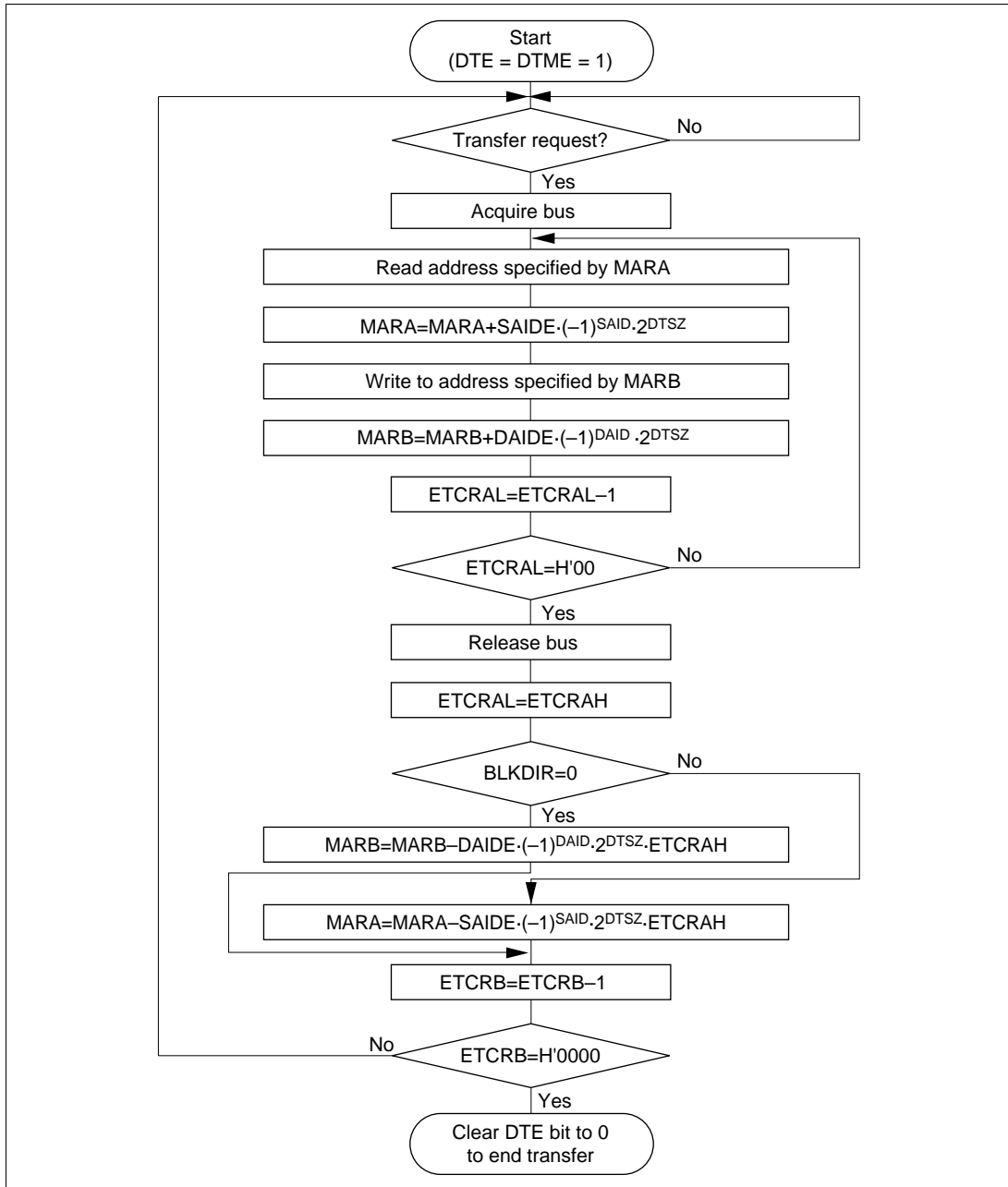


**Figure 8-14 Operation in Block Transfer Mode (BLKDIR = 1)**

ETCRAL is decremented by 1 each time a byte or word transfer is performed. In response to a single transfer request, burst transfer is performed until the value in ETCRAL reaches H'00. ETCRAL is then loaded with the value in ETCRAH. At this time, the value in the MAR register for which a block designation has been given by the BLKDIR bit in DMACRA is restored in accordance with the DTSZ, SAID/DAID, and SAIDE/DAIDE bits in DMACR.

ETCRB is decremented by 1 every block transfer, and when the count reaches H'0000 the DTE bit is cleared and transfer ends. If the DTIE bit is set to 1 at this point, an interrupt request is sent to the CPU or DTC.

Figure 8-15 shows the operation flow in block transfer mode.

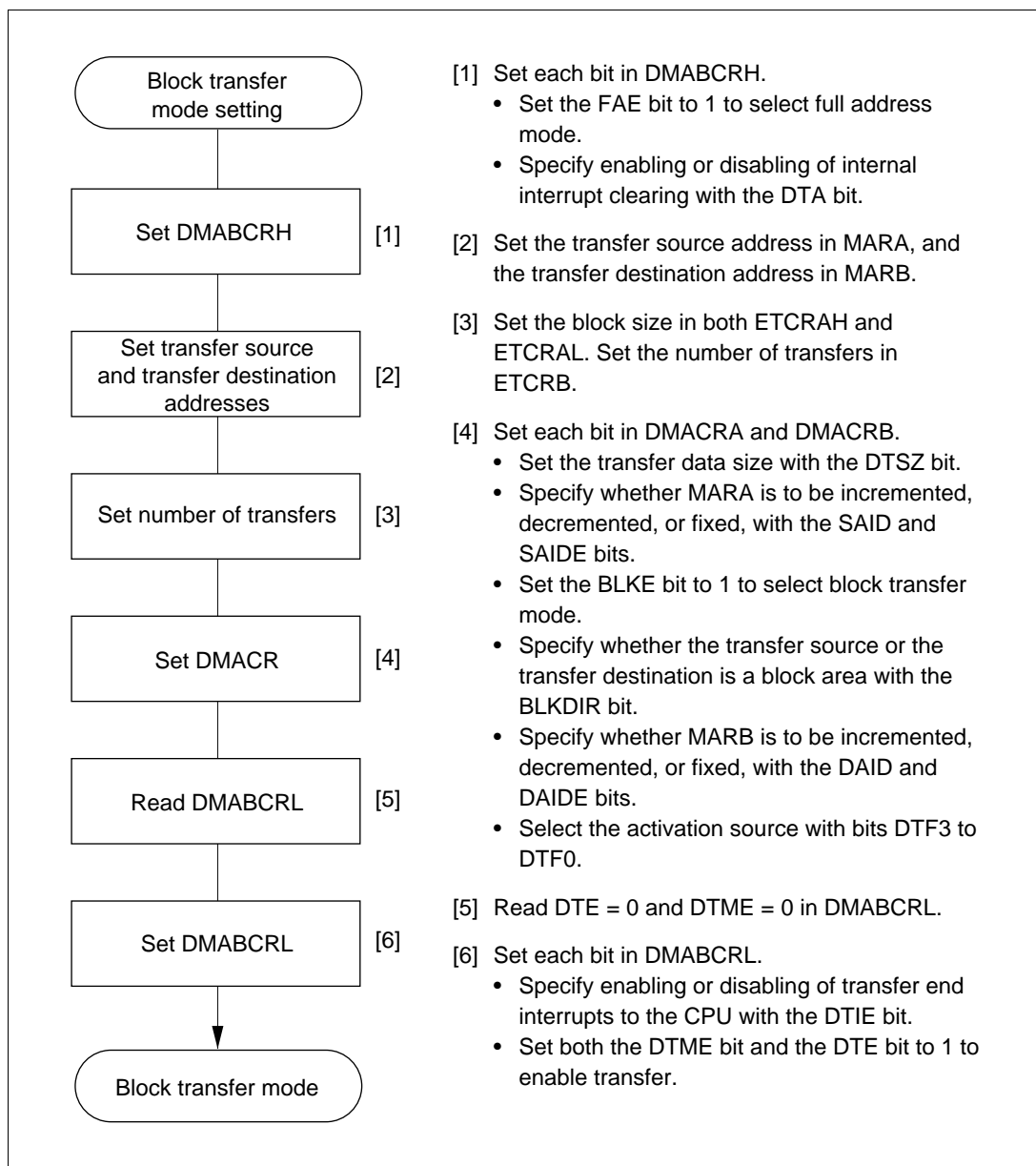


**Figure 8-15 Operation Flow in Block Transfer Mode**

Transfer requests (activation sources) consist of A/D converter conversion end interrupts, external requests, SCI transmission complete and reception complete interrupts, and TPU channels 0 to 5 compare match/input capture A interrupts.

For details, see section 8.3.4, DMA Control Register (DMACR).

Figure 8-16 shows an example of the setting procedure for block transfer mode.



**Figure 8-16 Example of Block Transfer Mode Setting Procedure**

## 8.5.8 DMAC Activation Sources

DMAC activation sources consist of internal interrupts, external requests, and auto-requests. The activation sources that can be specified depend on the transfer mode and the channel, as shown in table 8-12.

**Table 8-12 DMAC Activation Sources**

Activation Source		Short Address Mode		Full Address Mode	
		Channels 0A and 1A	Channels 0B and 1B	Normal Mode	Block Transfer Mode
Internal Interrupts	ADI	○	○	X	○
	TXI0	○	○	X	○
	RXI0	○	○	X	○
	TXI1	○	○	X	○
	RXI1	○	○	X	○
	TGI0A	○	○	X	○
	TGI1A	○	○	X	○
	TGI2A	○	○	X	○
	TGI3A	○	○	X	○
	TGI4A	○	○	X	○
	TGI5A	○	○	X	○
External Requests	$\overline{\text{DREQ}}$ pin falling edge input	X	○	○	○
	$\overline{\text{DREQ}}$ pin low-level input	X	○	○	○
Auto-request		X	X	○	X

### Legend

○ : Can be specified

X : Cannot be specified

**Activation by Internal Interrupt:** An interrupt request selected as a DMAC activation source can be sent simultaneously to the CPU and DTC. For details, see section 5, Interrupt Controller.

With activation by an internal interrupt, the DMAC accepts the request independently of the interrupt controller. Consequently, interrupt controller priority settings are not accepted.

If the DMAC is activated by a CPU interrupt source or an interrupt source that is not used as a DTC activation source ( $\text{DTA} = 1$ ), the interrupt source flag is cleared automatically by the DMA transfer. With ADI, TXI, and RXI interrupts, however, the interrupt source flag is not cleared unless the prescribed register is accessed in a DMA transfer. If the same interrupt is used as an



activation source for more than one channel, the interrupt request flag is cleared when the highest-priority channel is activated first. Transfer requests for other channels are held pending in the DMAC, and activation is carried out in order of priority.

When DTE = 0, such as after completion of a transfer, a request from the selected activation source is not sent to the DMAC, regardless of the DTA bit. In this case, the relevant interrupt request is sent to the CPU or DTC.

In case of overlap with a CPU interrupt source or DTC activation source (DTA = 0), the interrupt request flag is not cleared by the DMAC.

**Activation by External Request:** If an external request ( $\overline{\text{DREQ}}$  pin) is specified as an activation source, the relevant port should be set to input mode in advance.

Level sensing or edge sensing can be used for external requests.

External request operation in normal mode (short address mode or full address mode) is described below.

When edge sensing is selected, a 1-byte or 1-word transfer is executed each time a high-to-low transition is detected on the  $\overline{\text{DREQ}}$  pin. The next transfer may not be performed if the next edge is input before transfer is completed.

When level sensing is selected, the DMAC stands by for a transfer request while the  $\overline{\text{DREQ}}$  pin is held high. While the  $\overline{\text{DREQ}}$  pin is held low, transfers continue in succession, with the bus being released each time a byte or word is transferred. If the  $\overline{\text{DREQ}}$  pin goes high in the middle of a transfer, the transfer is interrupted and the DMAC stands by for a transfer request.

**Activation by Auto-Request:** Auto-request activation is performed by register setting only, and transfer continues to the end.

With auto-request activation, cycle steal mode or burst mode can be selected.

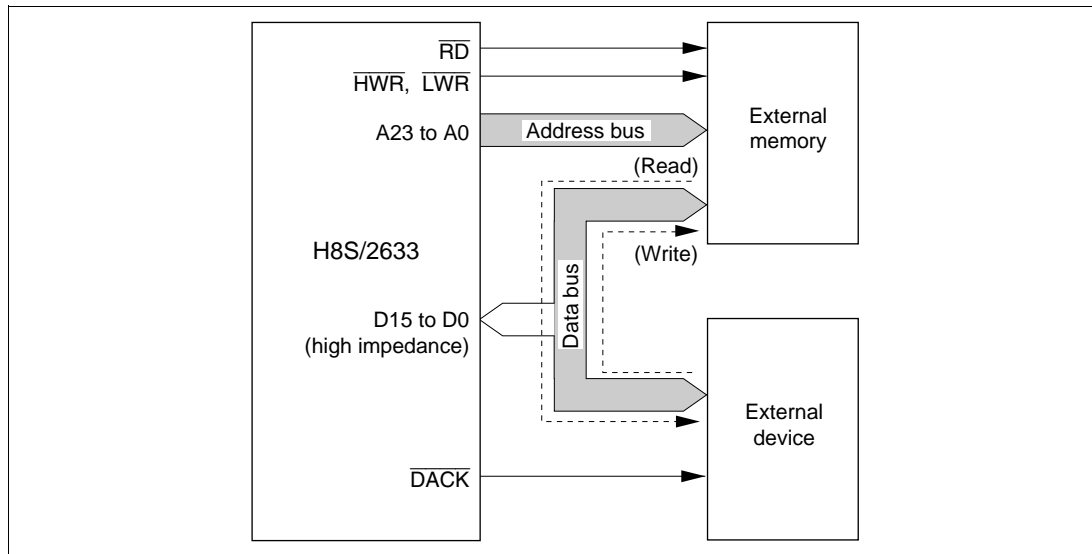
In cycle steal mode, the DMAC releases the bus to another bus master each time a byte or word is transferred. DMA and CPU cycles usually alternate.

In burst mode, the DMAC keeps possession of the bus until the end of the transfer, and transfer is performed continuously.

**Single Address Mode:** The DMAC can operate in dual address mode in which read cycles and write cycles are separate cycles, or single address mode in which read and write cycles are executed in parallel.

In dual address mode, transfer is performed with the source address and destination address specified separately.

In single address mode, on the other hand, transfer is performed between external space in which either the transfer source or the transfer destination is specified by an address, and an external device for which selection is performed by means of the  $\overline{\text{DACK}}$  strobe, without regard to the address. Figure 8-17 shows the data bus in single address mode.



**Figure 8-17 Data Bus in Single Address Mode**

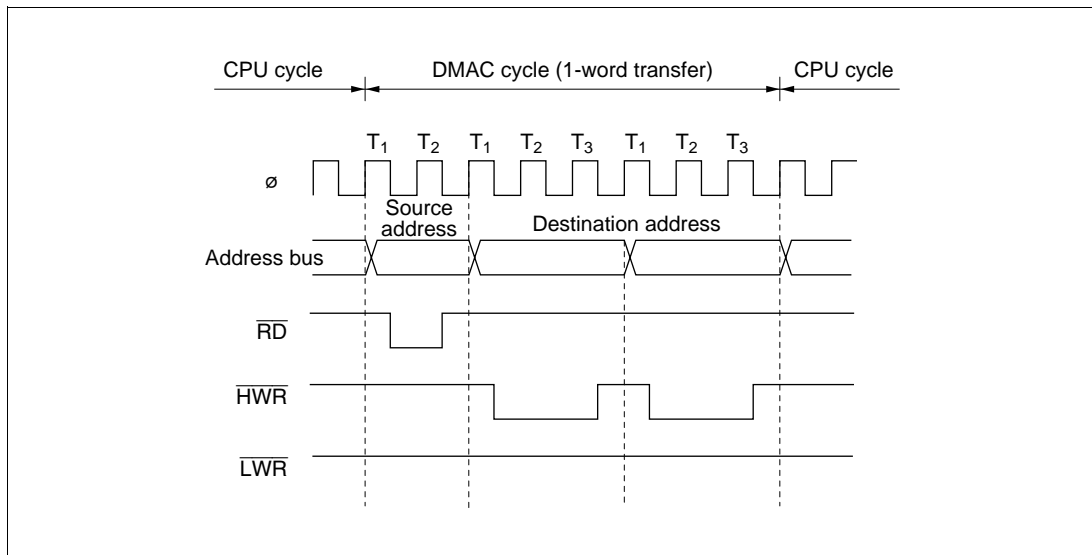
When using the DMAC for single address mode reading, transfer is performed from external memory to the external device, and the  $\overline{\text{DACK}}$  pin functions as a write strobe for the external device. When using the DMAC for single address mode writing, transfer is performed from the external device to external memory, and the  $\overline{\text{DACK}}$  pin functions as a read strobe for the external device. Since there is no directional control for the external device, one or other of the above single directions should be used.

Bus cycles in single address mode are in accordance with the settings of the bus controller for the external memory area. On the external device side,  $\overline{\text{DACK}}$  is output in synchronization with the address strobe. For details of bus cycles, see section 8.5.11, DMAC Bus Cycles (Single Address Mode).

Do not specify internal space for transfer addresses in single address mode.

### 8.5.9 Basic DMAC Bus Cycles

An example of the basic DMAC bus cycle timing is shown in figure 8-18. In this example, word-size transfer is performed from 16-bit, 2-state access space to 8-bit, 3-state access space. When the bus is transferred from the CPU to the DMAC, a source address read and destination address write are performed. The bus is not released in response to another bus request, etc., between these read and write operations. As with CPU cycles, DMA cycles conform to the bus controller settings.

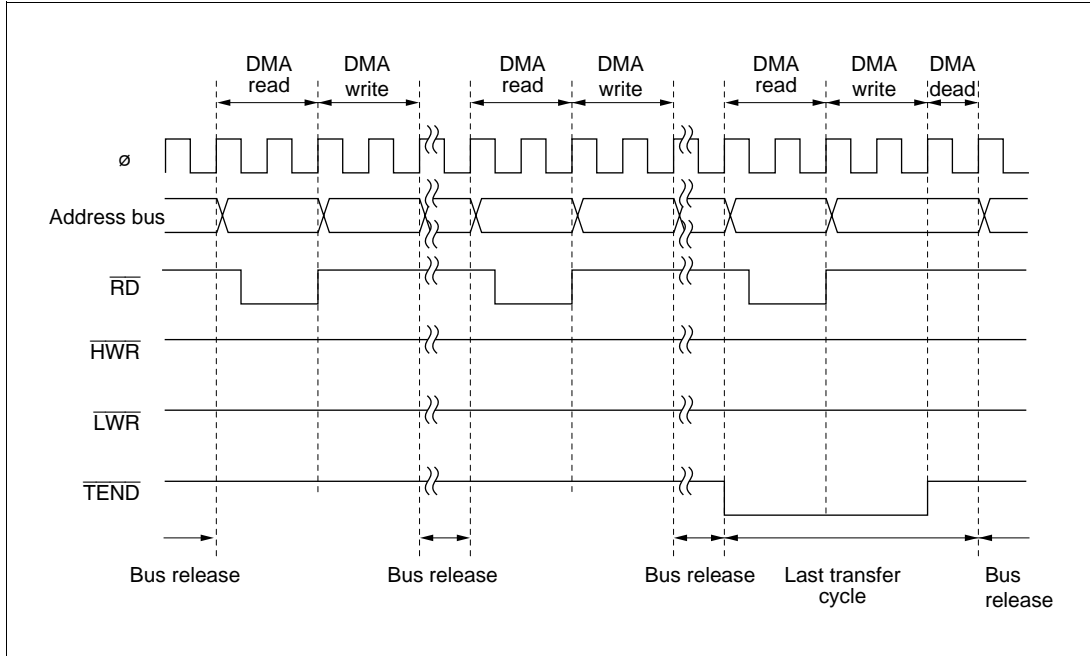


**Figure 8-18 Example of DMA Transfer Bus Timing**

The address is not output to the external address bus in an access to on-chip memory or an internal I/O register.

### 8.5.10 DMAC Bus Cycles (Dual Address Mode)

**Short Address Mode:** Figure 8-19 shows a transfer example in which  $\overline{\text{TEND}}$  output is enabled and byte-size short address mode transfer (sequential/idle/repeat mode) is performed from external 8-bit, 2-state access space to internal I/O space.



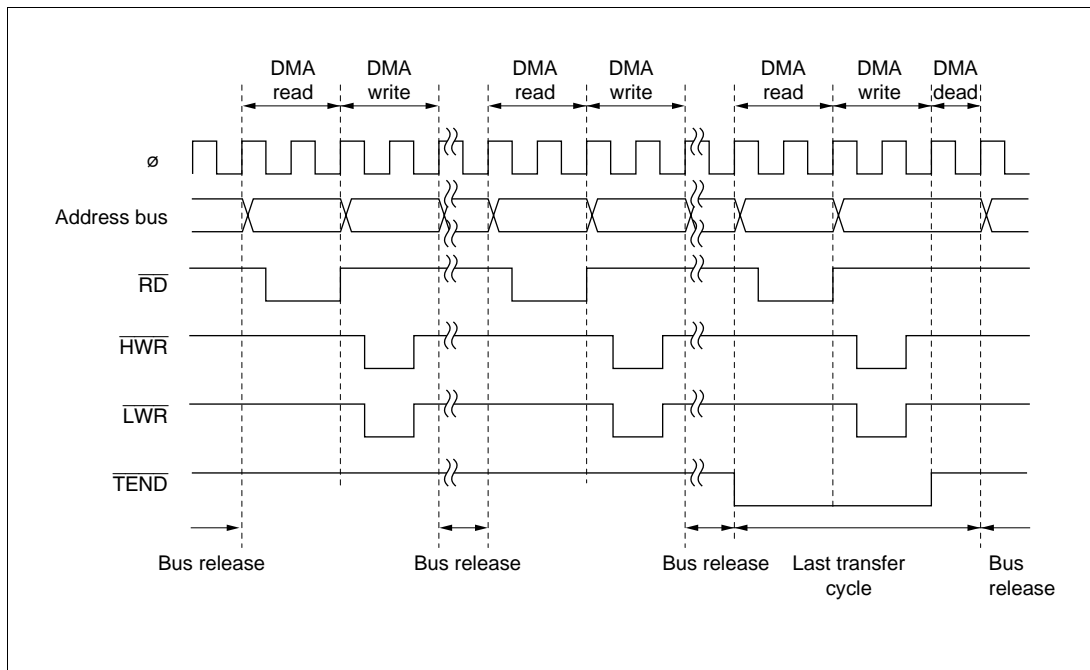
**Figure 8-19 Example of Short Address Mode Transfer**

A one-byte or one-word transfer is performed for one transfer request, and after the transfer the bus is released. While the bus is released one or more bus cycles are inserted by the CPU or DTC.

In the transfer end cycle (the cycle in which the transfer counter reaches 0), a one-state DMA dead cycle is inserted after the DMA write cycle.

In repeat mode, when  $\overline{\text{TEND}}$  output is enabled,  $\overline{\text{TEND}}$  output goes low in the transfer cycle in which the transfer counter reaches 0.

**Full Address Mode (Cycle Steal Mode):** Figure 8-20 shows a transfer example in which  $\overline{\text{TEND}}$  output is enabled and word-size full address mode transfer (cycle steal mode) is performed from external 16-bit, 2-state access space to external 16-bit, 2-state access space.

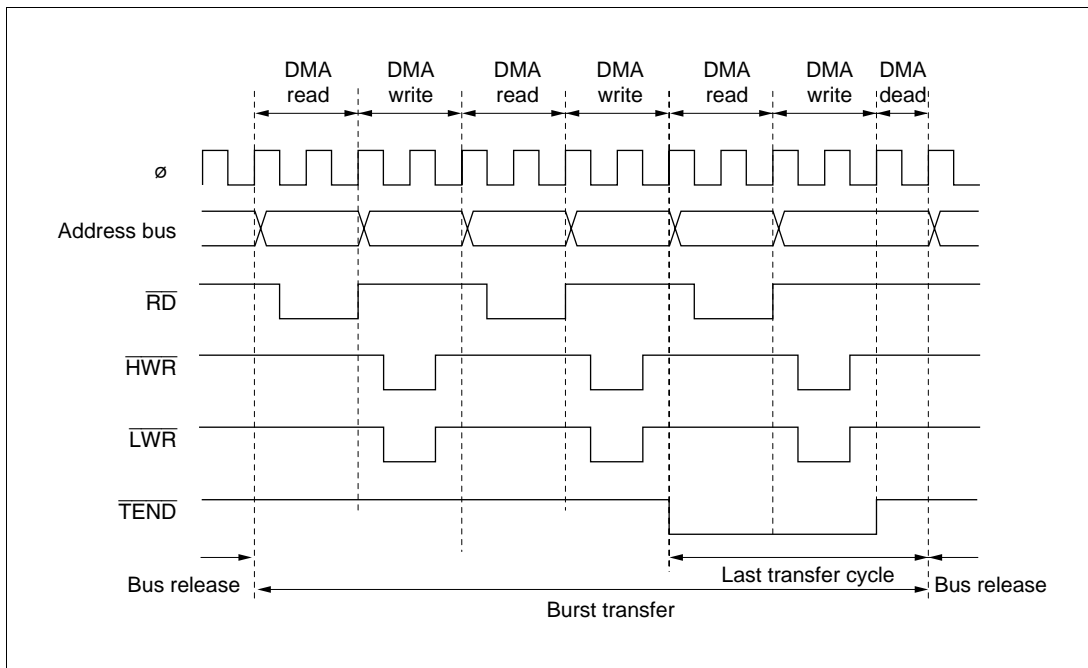


**Figure 8-20 Example of Full Address Mode (Cycle Steal) Transfer**

A one-byte or one-word transfer is performed, and after the transfer the bus is released. While the bus is released one bus cycle is inserted by the CPU or DTC.

In the transfer end cycle (the cycle in which the transfer counter reaches 0), a one-state DMA dead cycle is inserted after the DMA write cycle.

**Full Address Mode (Burst Mode):** Figure 8-21 shows a transfer example in which  $\overline{\text{TEND}}$  output is enabled and word-size full address mode transfer (burst mode) is performed from external 16-bit, 2-state access space to external 16-bit, 2-state access space.



**Figure 8-21 Example of Full Address Mode (Burst Mode) Transfer**

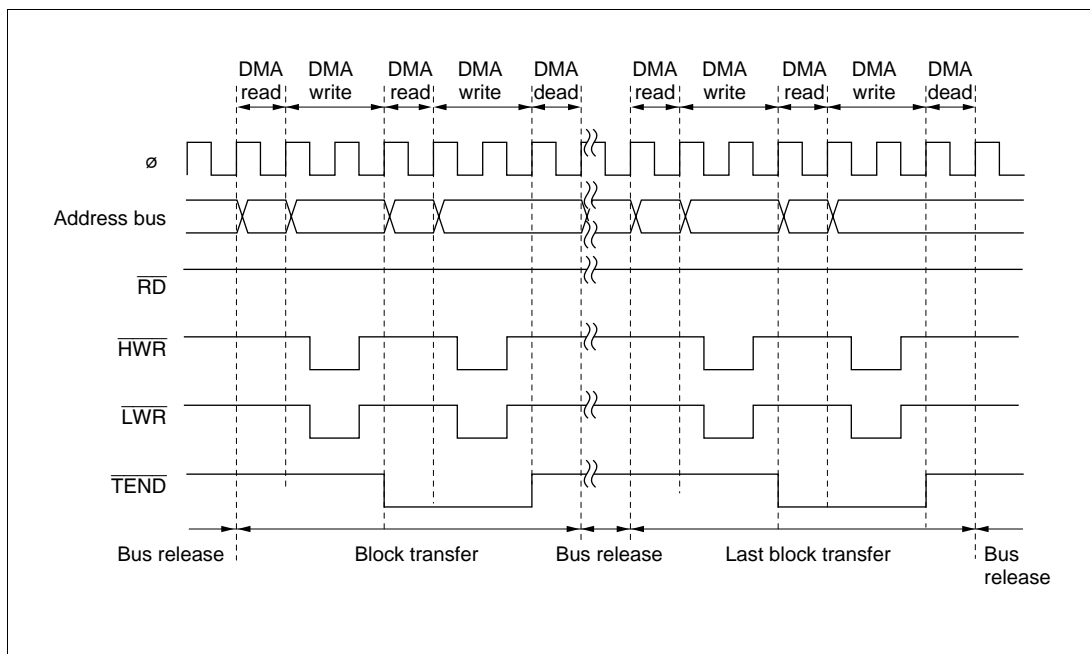
In burst mode, one-byte or one-word transfers are executed consecutively until transfer ends.

In the transfer end cycle (the cycle in which the transfer counter reaches 0), a one-state DMA dead cycle is inserted after the DMA write cycle.

If a request from another higher-priority channel is generated after burst transfer starts, that channel has to wait until the burst transfer ends.

If an NMI is generated while a channel designated for burst transfer is in the transfer enabled state, the DTME bit is cleared and the channel is placed in the transfer disabled state. If burst transfer has already been activated inside the DMAC, the bus is released on completion of a one-byte or one-word transfer within the burst transfer, and burst transfer is suspended. If the last transfer cycle of the burst transfer has already been activated inside the DMAC, execution continues to the end of the transfer even if the DTME bit is cleared.

**Full Address Mode (Block Transfer Mode):** Figure 8-22 shows a transfer example in which  $\overline{\text{TEND}}$  output is enabled and word-size full address mode transfer (block transfer mode) is performed from internal 16-bit, 1-state access space to external 16-bit, 2-state access space.



**Figure 8-22 Example of Full Address Mode (Block Transfer Mode) Transfer**

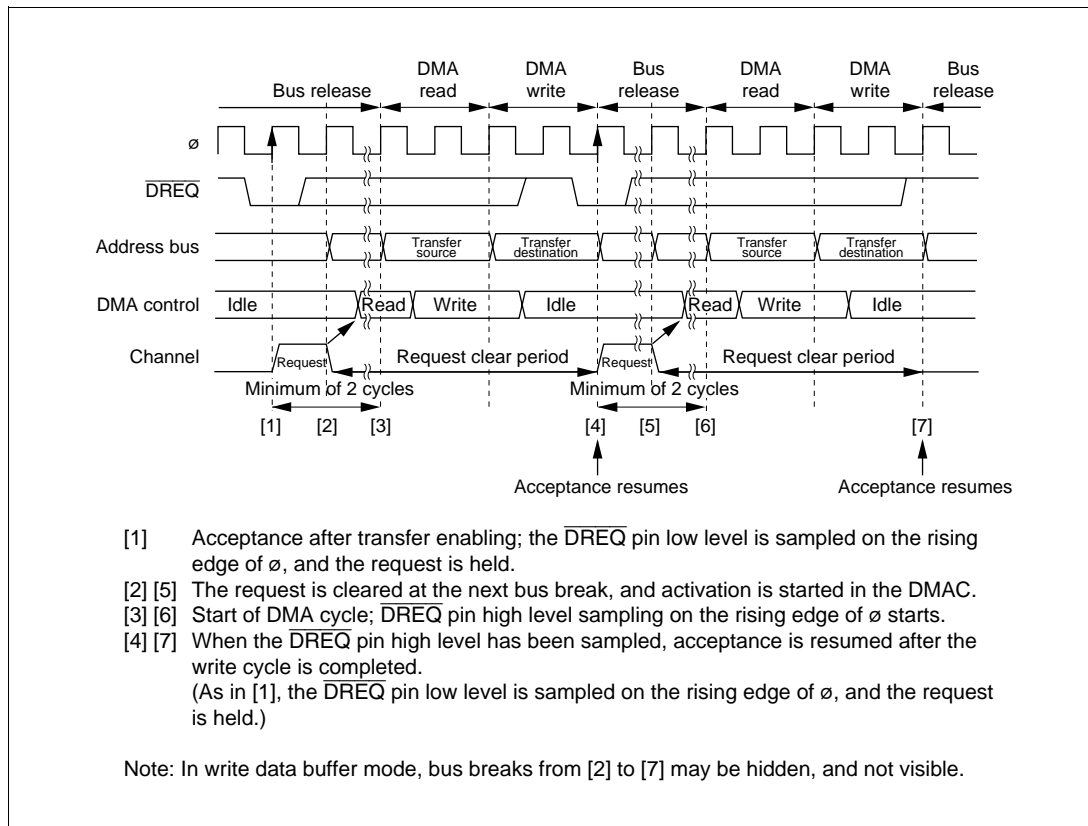
A one-block transfer is performed for one transfer request, and after the transfer the bus is released. While the bus is released, one or more bus cycles are inserted by the CPU or DTC.

In the transfer end cycle of each block (the cycle in which the transfer counter reaches 0), a one-state DMA dead cycle is inserted after the DMA write cycle.

One block is transmitted without interruption. NMI generation does not affect block transfer operation.

**$\overline{\text{DREQ}}$  Pin Falling Edge Activation Timing:** Set the DTA bit for the channel for which the  $\overline{\text{DREQ}}$  pin is selected to 1.

Figure 8-23 shows an example of  $\overline{\text{DREQ}}$  pin falling edge activated normal mode transfer.



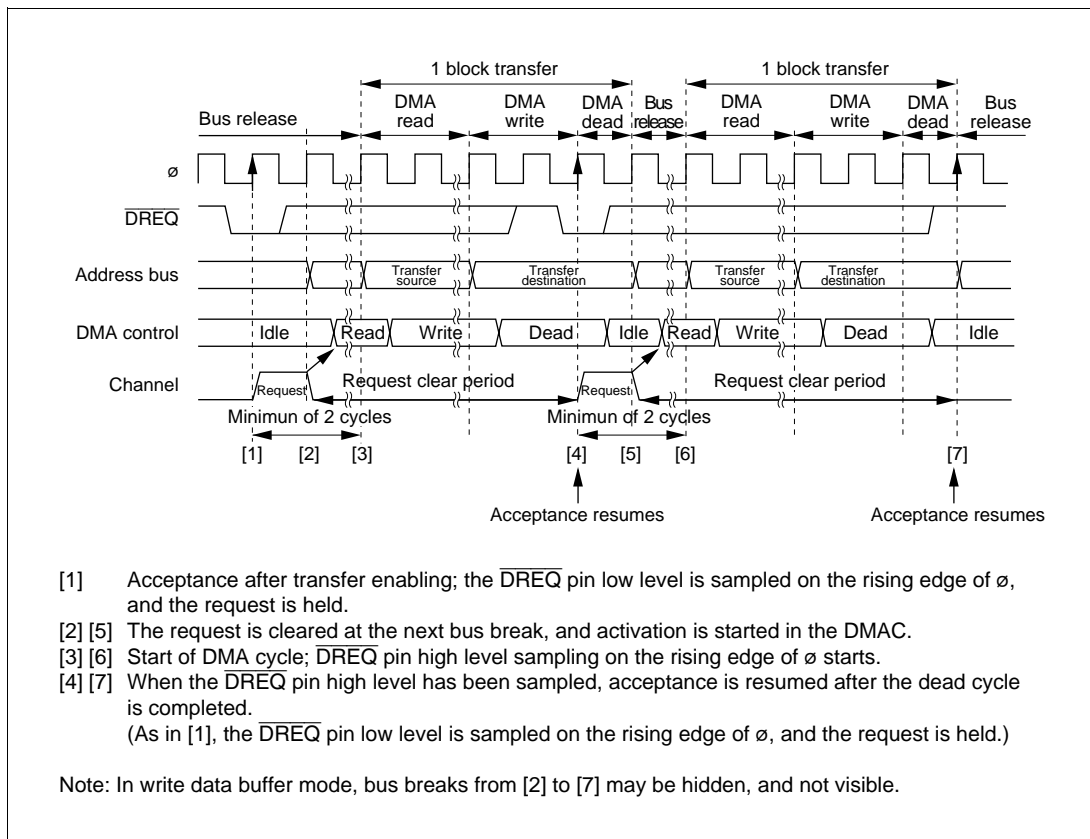
**Figure 8-23 Example of  $\overline{\text{DREQ}}$  Pin Falling Edge Activated Normal Mode Transfer**

$\overline{\text{DREQ}}$  pin sampling is performed every cycle, with the rising edge of the next  $\emptyset$  cycle after the end of the DMABCR write cycle for setting the transfer enabled state as the starting point.

When the  $\overline{\text{DREQ}}$  pin low level is sampled while acceptance by means of the  $\overline{\text{DREQ}}$  pin is possible, the request is held in the DMAC. Then, when activation is initiated in the DMAC, the request is cleared, and  $\overline{\text{DREQ}}$  pin high level sampling for edge detection is started. If  $\overline{\text{DREQ}}$  pin high level sampling has been completed by the time the DMA write cycle ends, acceptance resumes after the end of the write cycle,  $\overline{\text{DREQ}}$  pin low level sampling is performed again, and this operation is repeated until the transfer ends.



Figure 8-24 shows an example of  $\overline{\text{DREQ}}$  pin falling edge activated block transfer mode transfer.



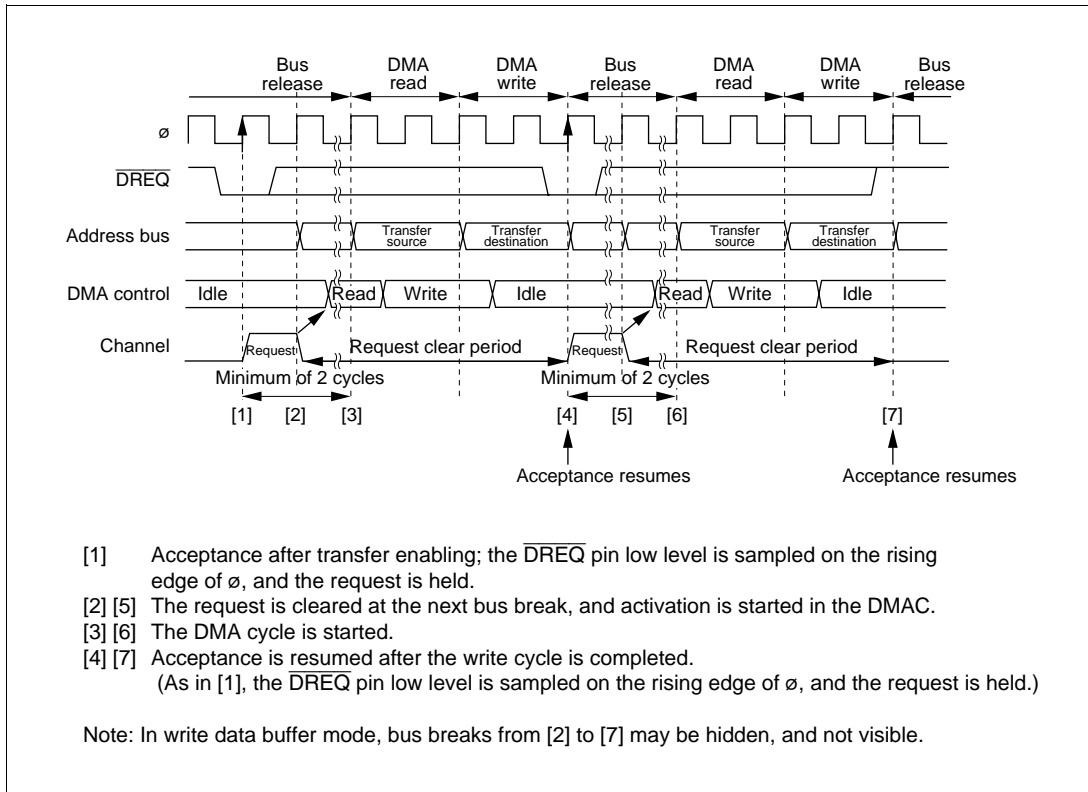
**Figure 8-24 Example of  $\overline{\text{DREQ}}$  Pin Falling Edge Activated Block Transfer Mode Transfer**

$\overline{\text{DREQ}}$  pin sampling is performed every cycle, with the rising edge of the next  $\phi$  cycle after the end of the DMABCR write cycle for setting the transfer enabled state as the starting point.

When the  $\overline{\text{DREQ}}$  pin low level is sampled while acceptance by means of the  $\overline{\text{DREQ}}$  pin is possible, the request is held in the DMAC. Then, when activation is initiated in the DMAC, the request is cleared, and  $\overline{\text{DREQ}}$  pin high level sampling for edge detection is started. If  $\overline{\text{DREQ}}$  pin high level sampling has been completed by the time the DMA dead cycle ends, acceptance resumes after the end of the dead cycle,  $\overline{\text{DREQ}}$  pin low level sampling is performed again, and this operation is repeated until the transfer ends.

**$\overline{\text{DREQ}}$  Level Activation Timing (Normal Mode):** Set the DTA bit for the channel for which the  $\overline{\text{DREQ}}$  pin is selected to 1.

Figure 8-25 shows an example of  $\overline{\text{DREQ}}$  level activated normal mode transfer.

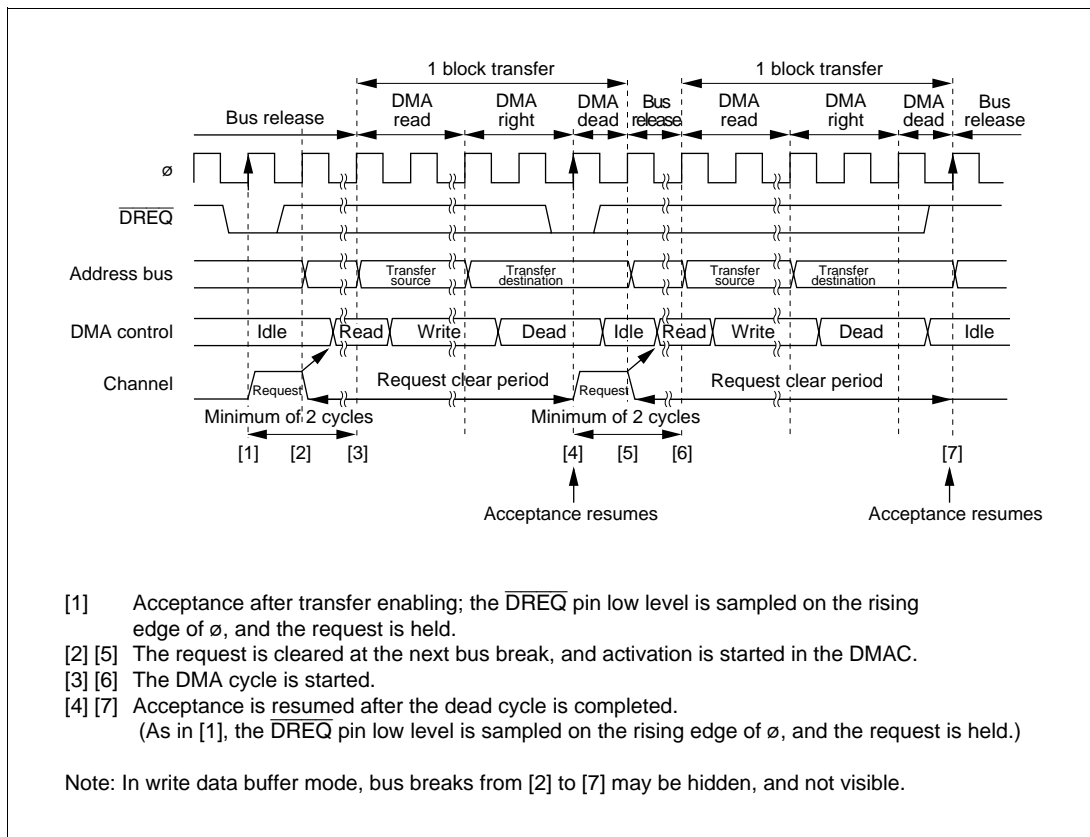


**Figure 8-25 Example of  $\overline{\text{DREQ}}$  Level Activated Normal Mode Transfer**

$\overline{\text{DREQ}}$  pin sampling is performed every cycle, with the rising edge of the next  $\phi$  cycle after the end of the DMABCR write cycle for setting the transfer enabled state as the starting point.

When the  $\overline{\text{DREQ}}$  pin low level is sampled while acceptance by means of the  $\overline{\text{DREQ}}$  pin is possible, the request is held in the DMAC. Then, when activation is initiated in the DMAC, the request is cleared. After the end of the write cycle, acceptance resumes,  $\overline{\text{DREQ}}$  pin low level sampling is performed again, and this operation is repeated until the transfer ends.

Figure 8-26 shows an example of  $\overline{\text{DREQ}}$  level activated block transfer mode transfer.



**Figure 8-26 Example of  $\overline{\text{DREQ}}$  Level Activated Block Transfer Mode Transfer**

$\overline{\text{DREQ}}$  pin sampling is performed every cycle, with the rising edge of the next  $\phi$  cycle after the end of the DMABCR write cycle for setting the transfer enabled state as the starting point.

When the  $\overline{\text{DREQ}}$  pin low level is sampled while acceptance by means of the  $\overline{\text{DREQ}}$  pin is possible, the request is held in the DMAC. Then, when activation is initiated in the DMAC, the request is cleared. After the end of the dead cycle, acceptance resumes,  $\overline{\text{DREQ}}$  pin low level sampling is performed again, and this operation is repeated until the transfer ends.

### 8.5.11 DMAC Bus Cycles (Single Address Mode)

**Single Address Mode (Read):** Figure 8-27 shows a transfer example in which  $\overline{\text{TEND}}$  output is enabled and byte-size single address mode transfer (read) is performed from external 8-bit, 2-state access space to an external device.

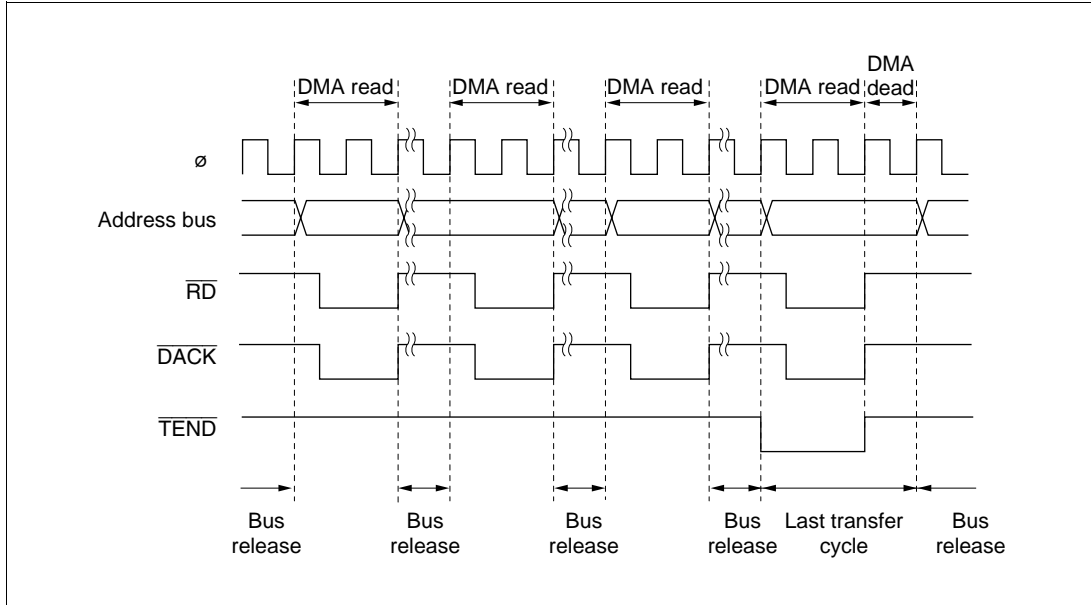
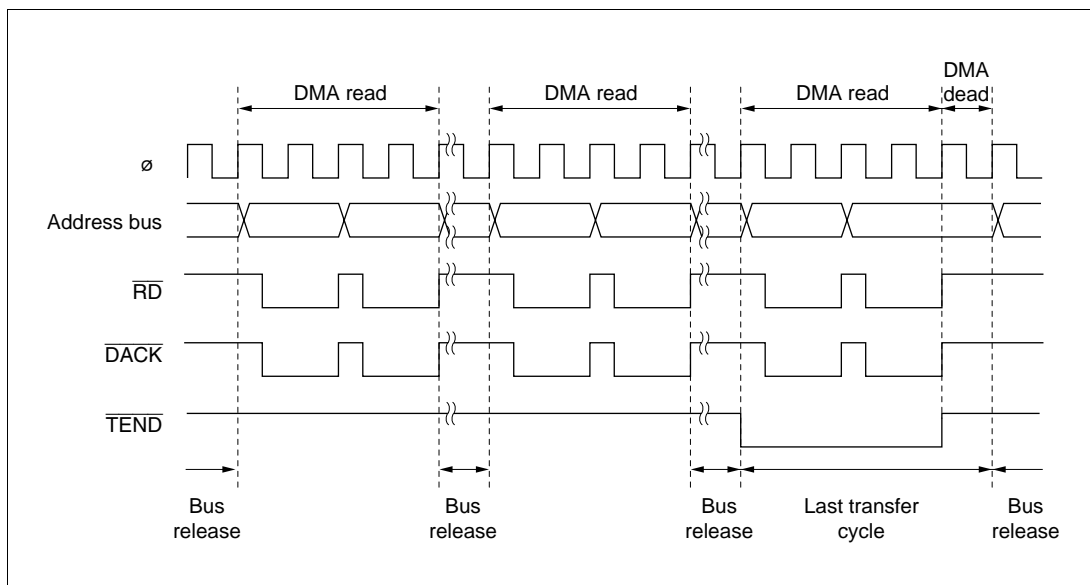


Figure 8-27 Example of Single Address Mode (Byte Read) Transfer

Figure 8-28 shows a transfer example in which  $\overline{\text{TEND}}$  output is enabled and word-size single address mode transfer (read) is performed from external 8-bit, 2-state access space to an external device.

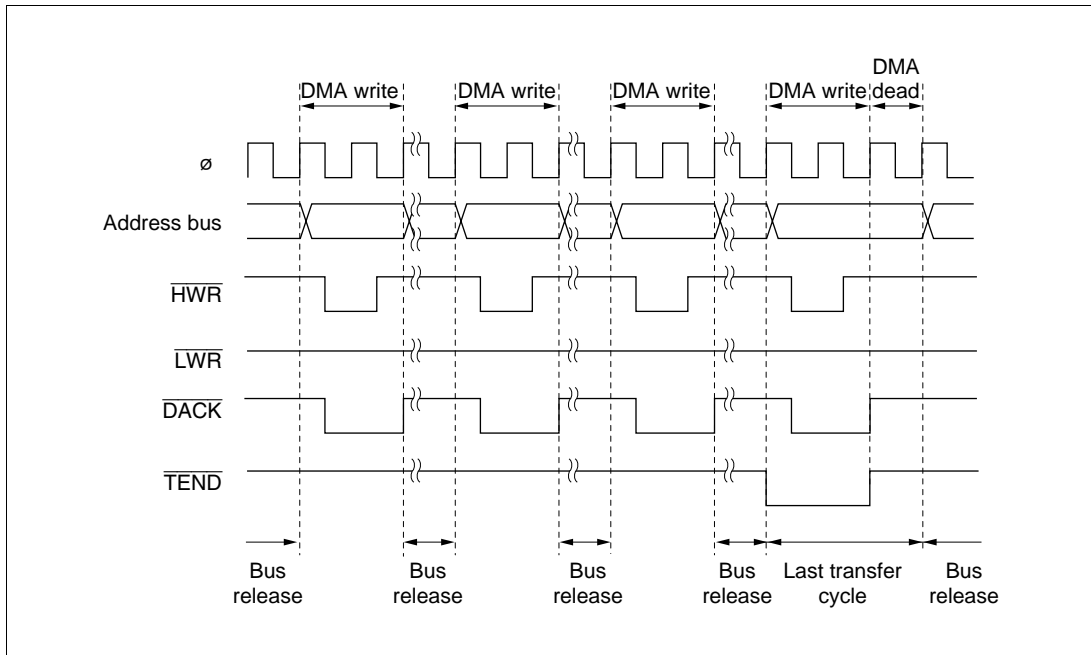


**Figure 8-28 Example of Single Address Mode (Word Read) Transfer**

A one-byte or one-word transfer is performed for one transfer request, and after the transfer the bus is released. While the bus is released, one or more bus cycles are inserted by the CPU or DTC.

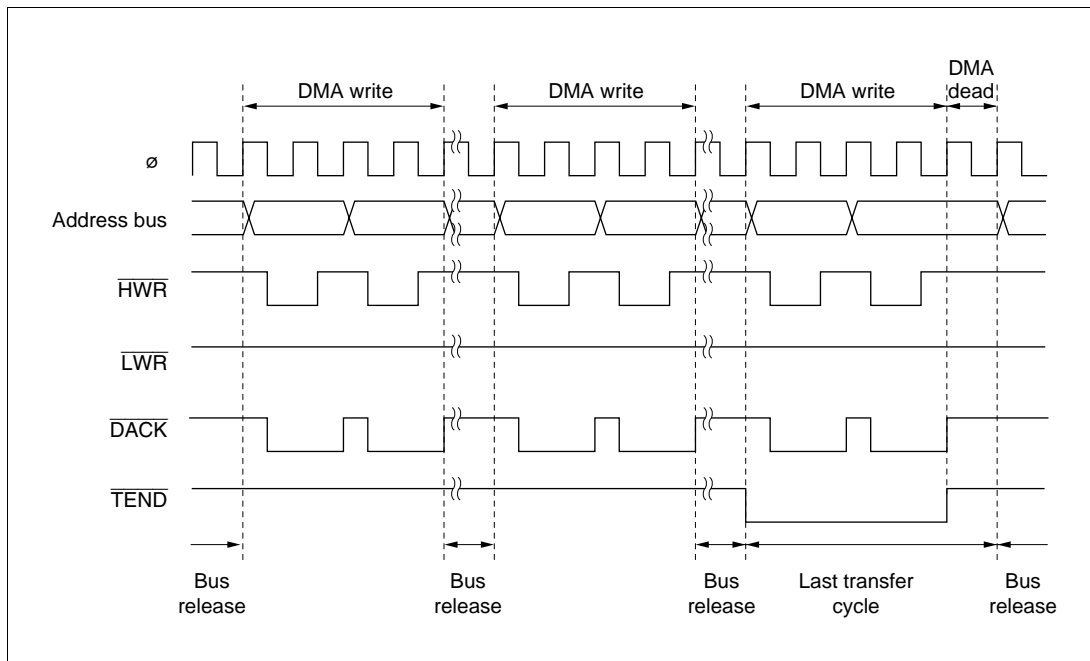
In the transfer end cycle (the cycle in which the transfer counter reaches 0), a one-state DMA dead cycle is inserted after the DMA write cycle.

**Single Address Mode (Write):** Figure 8-29 shows a transfer example in which  $\overline{\text{TEND}}$  output is enabled and byte-size single address mode transfer (write) is performed from an external device to external 8-bit, 2-state access space.



**Figure 8-29 Example of Single Address Mode (Byte Write) Transfer**

Figure 8-30 shows a transfer example in which  $\overline{\text{TEND}}$  output is enabled and word-size single address mode transfer (write) is performed from an external device to external 8-bit, 2-state access space.



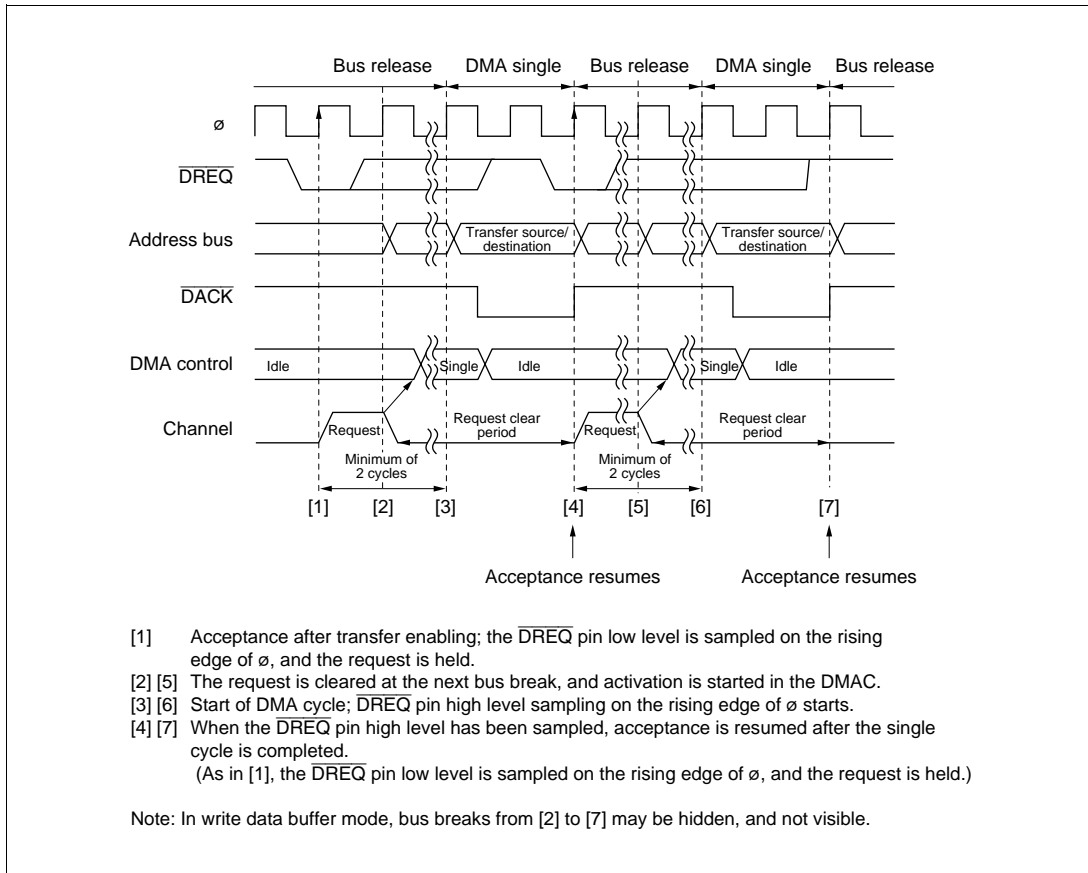
**Figure 8-30 Example of Single Address Mode (Word Write) Transfer**

A one-byte or one-word transfer is performed for one transfer request, and after the transfer the bus is released. While the bus is released one or more bus cycles are inserted by the CPU or DTC.

In the transfer end cycle (the cycle in which the transfer counter reaches 0), a one-state DMA dead cycle is inserted after the DMA write cycle.

**$\overline{\text{DREQ}}$  Pin Falling Edge Activation Timing:** Set the DTA bit for the channel for which the  $\overline{\text{DREQ}}$  pin is selected to 1.

Figure 8-31 shows an example of  $\overline{\text{DREQ}}$  pin falling edge activated single address mode transfer.



**Figure 8-31 Example of  $\overline{\text{DREQ}}$  Pin Falling Edge Activated Single Address Mode Transfer**

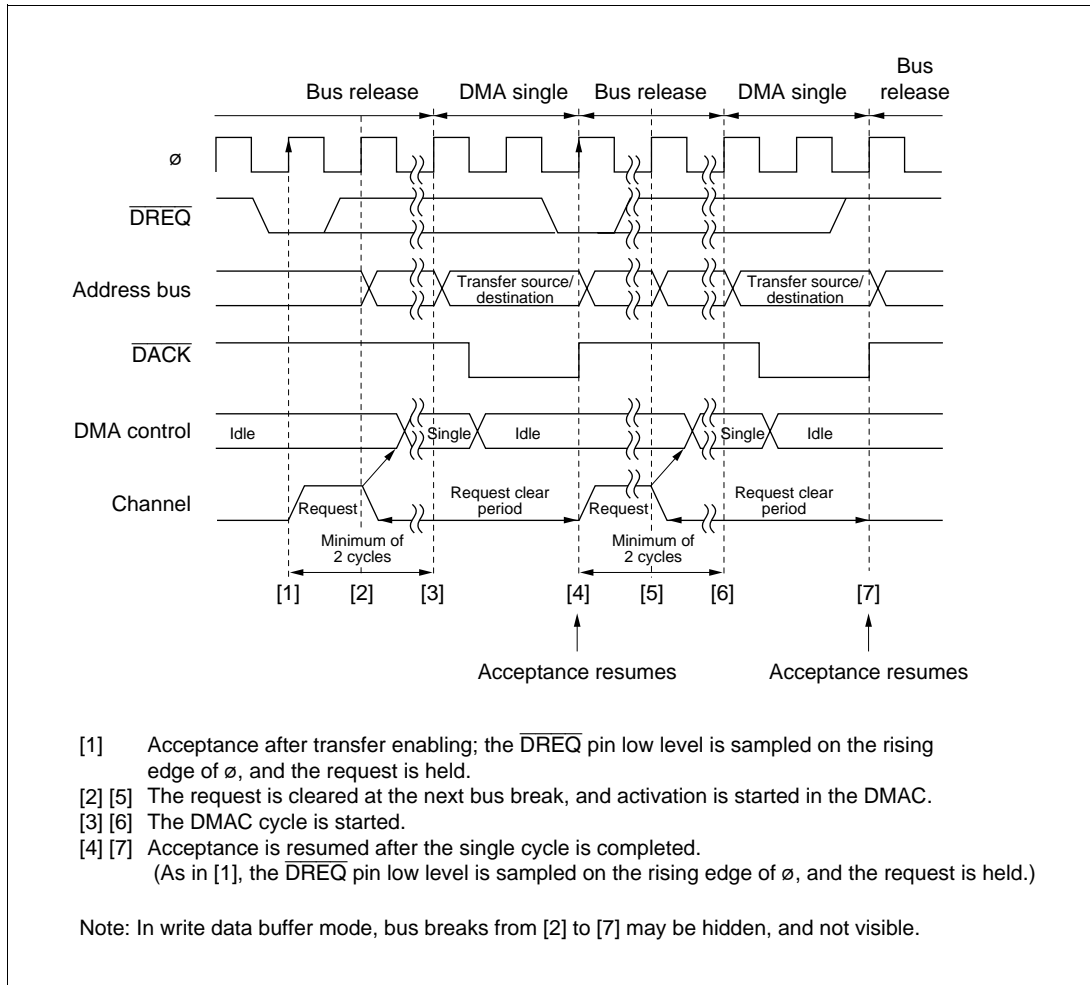
$\overline{\text{DREQ}}$  pin sampling is performed every cycle, with the rising edge of the next  $\phi$  cycle after the end of the DMABCR write cycle for setting the transfer enabled state as the starting point.

When the  $\overline{\text{DREQ}}$  pin low level is sampled while acceptance by means of the  $\overline{\text{DREQ}}$  pin is possible, the request is held in the DMAC. Then, when activation is initiated in the DMAC, the request is cleared, and  $\overline{\text{DREQ}}$  pin high level sampling for edge detection is started. If  $\overline{\text{DREQ}}$  pin high level sampling has been completed by the time the DMA single cycle ends, acceptance resumes after the end of the single cycle,  $\overline{\text{DREQ}}$  pin low level sampling is performed again, and this operation is repeated until the transfer ends.



**$\overline{\text{DREQ}}$  Pin Low Level Activation Timing:** Set the DTA bit for the channel for which the  $\overline{\text{DREQ}}$  pin is selected to 1.

Figure 8-32 shows an example of  $\overline{\text{DREQ}}$  pin low level activated single address mode transfer.



**Figure 8-32 Example of  $\overline{\text{DREQ}}$  Pin Low Level Activated Single Address Mode Transfer**

$\overline{\text{DREQ}}$  pin sampling is performed every cycle, with the rising edge of the next  $\phi$  cycle after the end of the DMABCR write cycle for setting the transfer enabled state as the starting point.

When the  $\overline{\text{DREQ}}$  pin low level is sampled while acceptance by means of the  $\overline{\text{DREQ}}$  pin is possible, the request is held in the DMAC. Then, when activation is initiated in the DMAC, the request is cleared. After the end of the single cycle, acceptance resumes,  $\overline{\text{DREQ}}$  pin low level sampling is performed again, and this operation is repeated until the transfer ends.

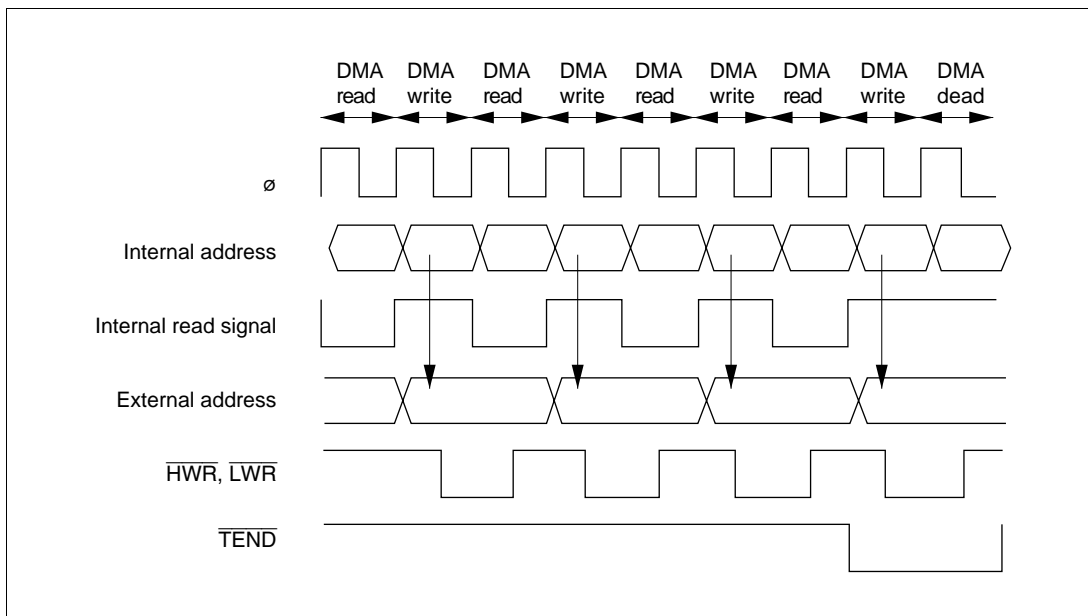
### 8.5.12 Write Data Buffer Function

DMAC internal-to-external dual address transfers and single address transfers can be executed at high speed using the write data buffer function, enabling system throughput to be improved.

When the WDBE bit of BCRL in the bus controller is set to 1, enabling the write data buffer function, dual address transfer external write cycles or single address transfers and internal accesses (on-chip memory or internal I/O registers) are executed in parallel. Internal accesses are independent of the bus master, and DMAC dead cycles are regarded as internal accesses.

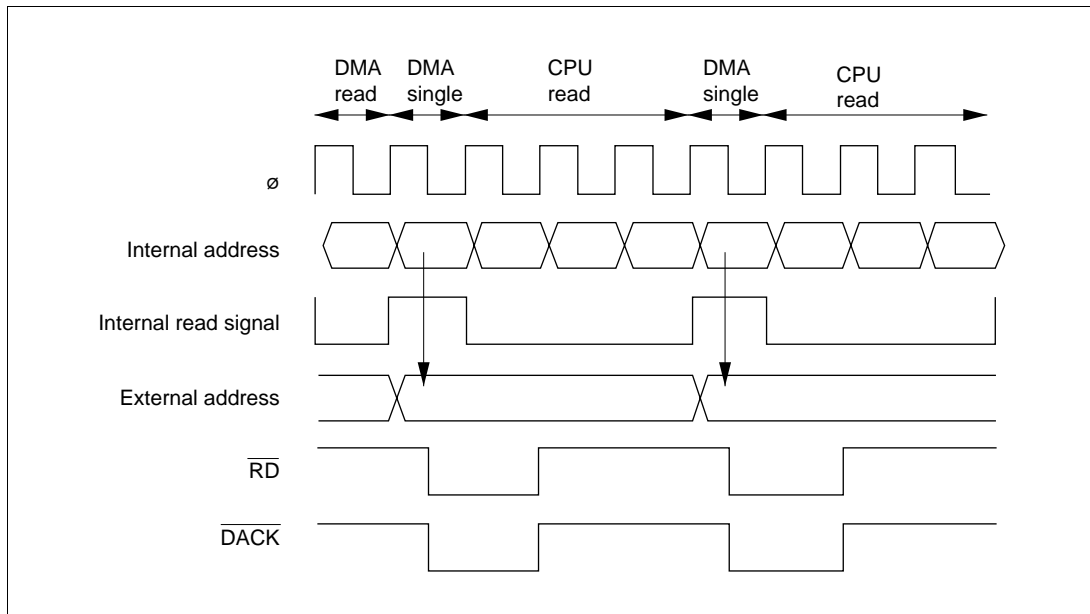
A low level can always be output from the  $\overline{\text{TEND}}$  pin if the bus cycle in which a low level is to be output is an external bus cycle. However, a low level is not output from the  $\overline{\text{TEND}}$  pin if the bus cycle in which a low level is to be output from the  $\overline{\text{TEND}}$  pin is an internal bus cycle, and an external write cycle is executed in parallel with this cycle.

Figure 8-33 shows an example of burst mode transfer from on-chip RAM to external memory using the write data buffer function.



**Figure 8-33 Example of Dual Address Transfer Using Write Data Buffer Function**

Figure 8-34 shows an example of single address transfer using the write data buffer function. In this example, the CPU program area is in on-chip memory.



**Figure 8-34 Example of Single Address Transfer Using Write Data Buffer Function**

When the write data buffer function is activated, the DMAC recognizes that the bus cycle concerned has ended, and starts the next operation. Therefore,  $\overline{\text{DREQ}}$  pin sampling is started one state after the start of the DMA write cycle or single address transfer.

### 8.5.13 DMAC Multi-Channel Operation

The DMAC channel priority order is: channel 0 > channel 1, and channel A > channel B. Table 8-13 summarizes the priority order for DMAC channels.

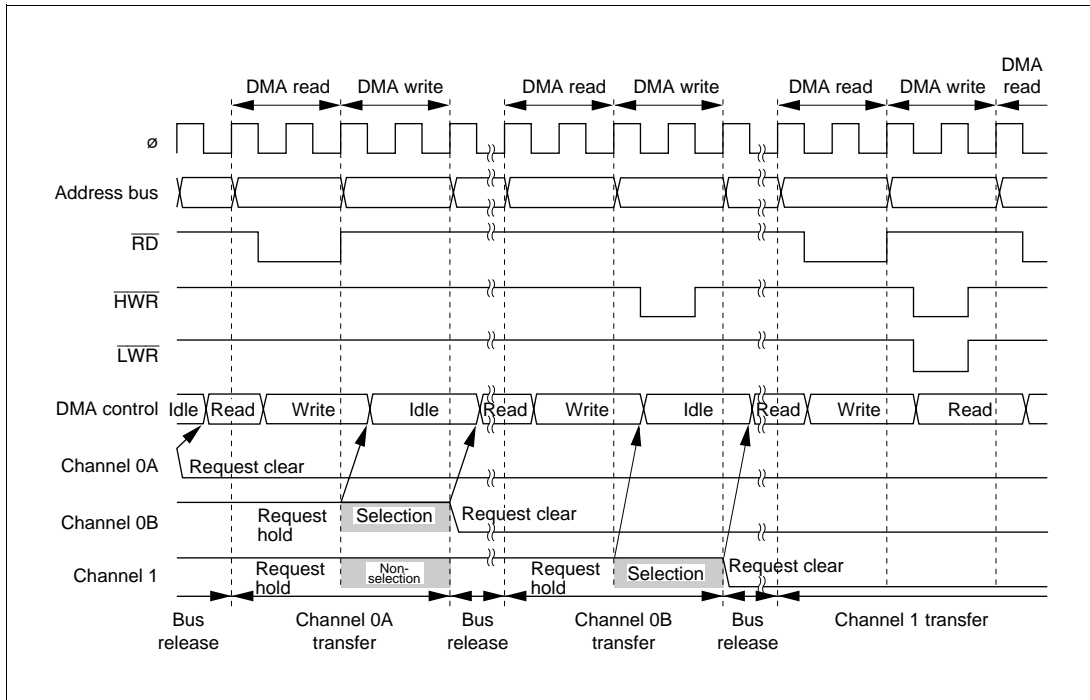
**Table 8-13 DMAC Channel Priority Order**

Short Address Mode	Full Address Mode	Priority
Channel 0A	Channel 0	High
Channel 0B		↕
Channel 1A	Channel 1	↕
Channel 1B		Low

If transfer requests are issued simultaneously for more than one channel, or if a transfer request for another channel is issued during a transfer, when the bus is released the DMAC selects the highest-priority channel from among those issuing a request according to the priority order shown in table 8-13.

During burst transfer, or when one block is being transferred in block transfer, the channel will not be changed until the end of the transfer.

Figure 8-35 shows a transfer example in which transfer requests are issued simultaneously for channels 0A, 0B, and 1.



**Figure 8-35 Example of Multi-Channel Transfer**

#### **8.5.14 Relation between External Bus Requests, Refresh Cycles, the DTC, and the DMAC**

There can be no break between a DMA cycle read and a DMA cycle write. This means that a refresh cycle, external bus release cycle, or DTC cycle is not generated between the external read and external write in a DMA cycle.

In the case of successive read and write cycles, such as in burst transfer or block transfer, a refresh or external bus released state may be inserted after a write cycle. Since the DTC has a lower priority than the DMAC, the DTC does not operate until the DMAC releases the bus.

When DMA cycle reads or writes are accesses to on-chip memory or internal I/O registers, these DMA cycles can be executed at the same time as refresh cycles or external bus release. However, simultaneous operation may not be possible when a write buffer is used.

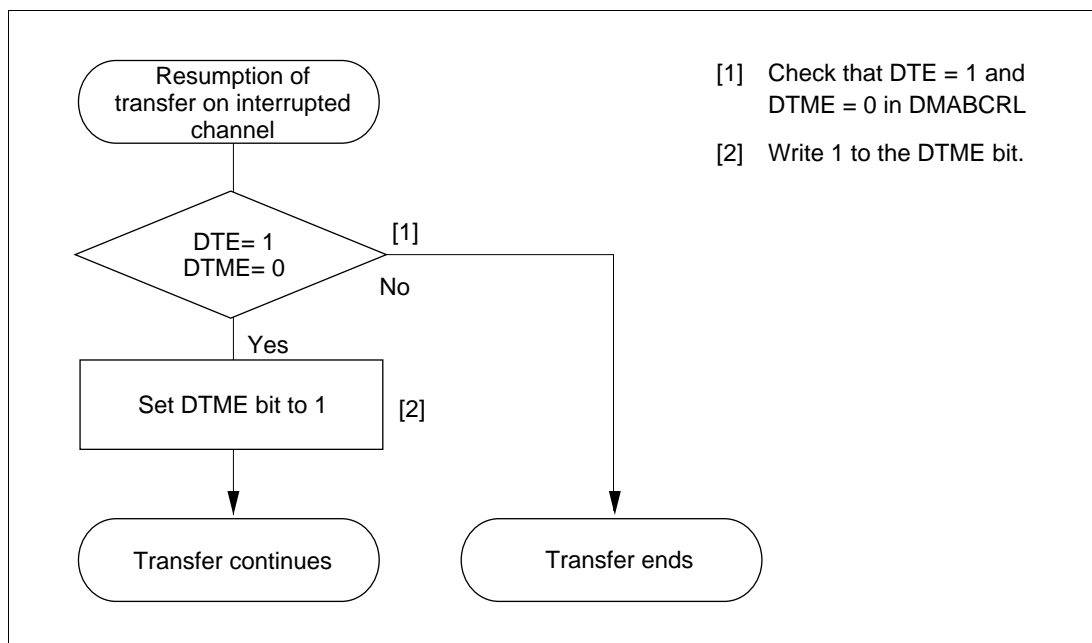
### 8.5.15 NMI Interrupts and DMAC

When an NMI interrupt is requested, burst mode transfer in full address mode is interrupted. An NMI interrupt does not affect the operation of the DMAC in other modes.

In full address mode, transfer is enabled for a channel when both the DTE bit and the DTME bit are set to 1. With burst mode setting, the DTME bit is cleared when an NMI interrupt is requested.

If the DTME bit is cleared during burst mode transfer, the DMAC discontinues transfer on completion of the 1-byte or 1-word transfer in progress, then releases the bus, which passes to the CPU.

The channel on which transfer was interrupted can be restarted by setting the DTME bit to 1 again. Figure 8-36 shows the procedure for continuing transfer when it has been interrupted by an NMI interrupt on a channel designated for burst mode transfer.



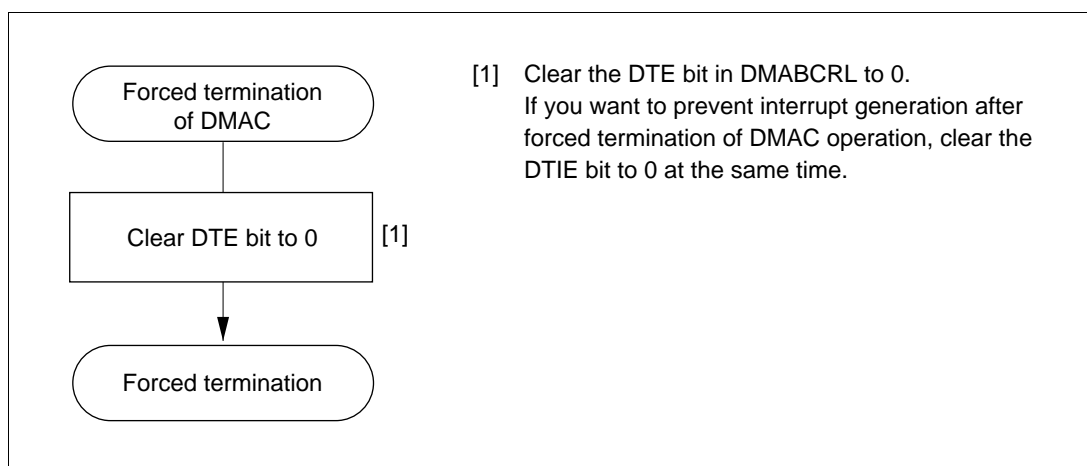
**Figure 8-36 Example of Procedure for Continuing Transfer on Channel Interrupted by NMI Interrupt**

### 8.5.16 Forced Termination of DMAC Operation

If the DTE bit for the channel currently operating is cleared to 0, the DMAC stops on completion of the 1-byte or 1-word transfer in progress. DMAC operation resumes when the DTE bit is set to 1 again.

In full address mode, the same applies to the DTME bit.

Figure 8-37 shows the procedure for forcibly terminating DMAC operation by software.



**Figure 8-37 Example of Procedure for Forcibly Terminating DMAC Operation**

### 8.5.17 Clearing Full Address Mode

Figure 8-38 shows the procedure for releasing and initializing a channel designated for full address mode. After full address mode has been cleared, the channel can be set to another transfer mode using the appropriate setting procedure.

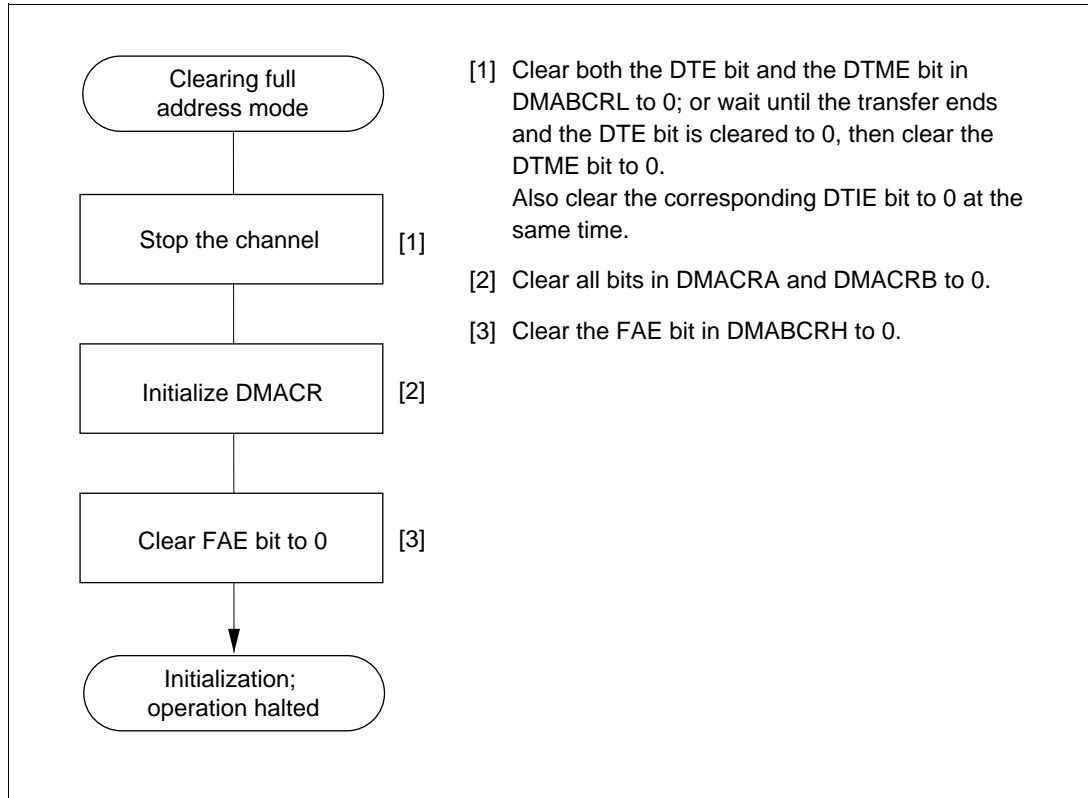


Figure 8-38 Example of Procedure for Clearing Full Address Mode



## 8.6 Interrupts

The sources of interrupts generated by the DMAC are transfer end and transfer break. Table 8-14 shows the interrupt sources and their priority order.

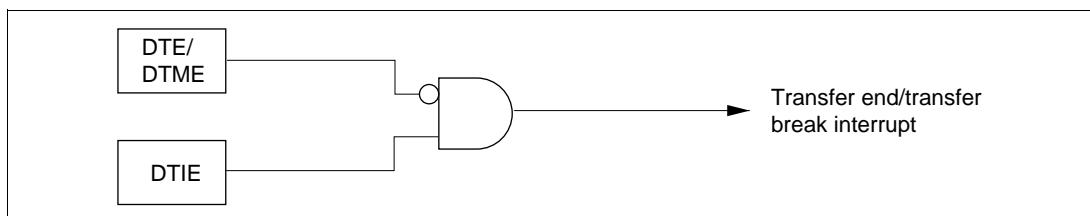
**Table 8-14 Interrupt Source Priority Order**

Interrupt Name	Interrupt Source		Interrupt Priority Order
	Short Address Mode	Full Address Mode	
DEND0A	Interrupt due to end of transfer on channel 0A	Interrupt due to end of transfer on channel 0	High ↑ ↓ Low
DEND0B	Interrupt due to end of transfer on channel 0B	Interrupt due to break in transfer on channel 0	
DEND1A	Interrupt due to end of transfer on channel 1A	Interrupt due to end of transfer on channel 1	
DEND1B	Interrupt due to end of transfer on channel 1B	Interrupt due to break in transfer on channel 1	

Enabling or disabling of each interrupt source is set by means of the DTIE bit for the corresponding channel in DMABCR, and interrupts from each source are sent to the interrupt controller independently.

The relative priority of transfer end interrupts on each channel is decided by the interrupt controller, as shown in table 8-14.

Figure 8-39 shows a block diagram of a transfer end/transfer break interrupt. An interrupt is always generated when the DTIE bit is set to 1 while DTE bit is cleared to 0.



**Figure 8-39 Block Diagram of Transfer End/Transfer Break Interrupt**

In full address mode, a transfer break interrupt is generated when the DTME bit is cleared to 0 while DTIEB bit is set to 1.

In both short address mode and full address mode, DMABCR should be set so as to prevent the occurrence of a combination that constitutes a condition for interrupt generation during setting.

## 8.7 Usage Notes

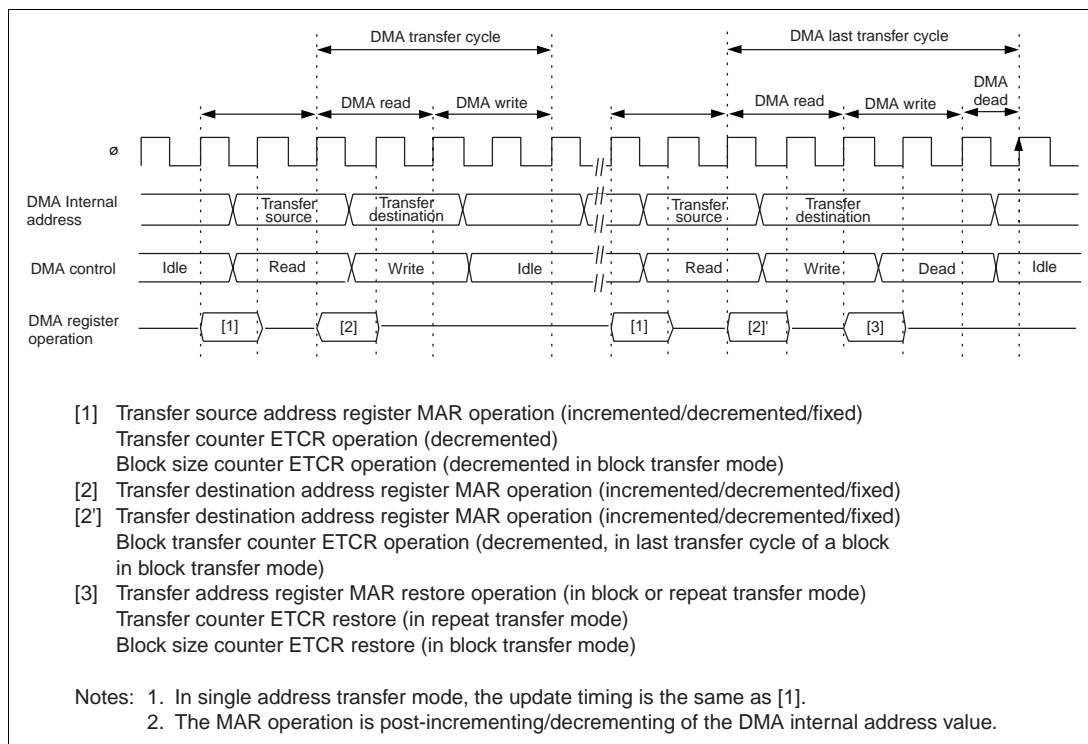
**DMAC Register Access during Operation:** Except for forced termination, the operating (including transfer waiting state) channel setting should not be changed. The operating channel setting should only be changed when transfer is disabled.

Also, the DMAC register should not be written to in a DMA transfer.

DMAC register reads during operation (including the transfer waiting state) are described below.

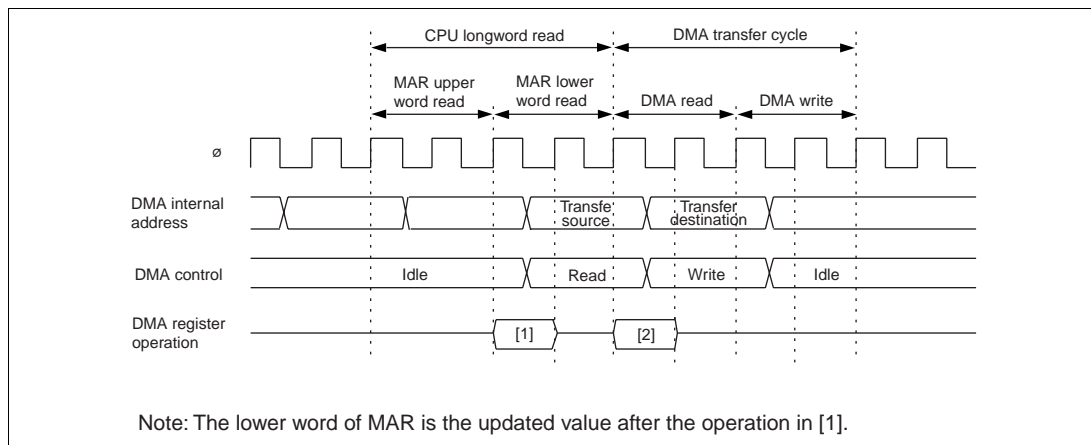
(a) DMAC control starts one cycle before the bus cycle, with output of the internal address. Consequently, MAR is updated in the bus cycle before DMAC transfer.

Figure 8-40 shows an example of the update timing for DMAC registers in dual address transfer mode.



**Figure 8-40 DMAC Register Update Timing**

(b) If a DMAC transfer cycle occurs immediately after a DMAC register read cycle, the DMAC register is read as shown in figure 8-41.



**Figure 8-41 Contention between DMAC Register Update and CPU Read**

**Module Stop:** When the MSTPA7 bit in MSTPCR is set to 1, the DMAC clock stops, and the module stop state is entered. However, 1 cannot be written to the MSTPA7 bit if any of the DMAC channels is enabled. This setting should therefore be made when DMAC operation is stopped.

When the DMAC clock stops, DMAC register accesses can no longer be made. Since the following DMAC register settings are valid even in the module stop state, they should be invalidated, if necessary, before a module stop.

- Transfer end/suspend interrupt (DTE = 0 and DTIE = 1)
- $\overline{\text{TEND}}$  pin enable (TEE = 1)
- $\overline{\text{DACK}}$  pin enable (FAE = 0 and SAE = 1)

**Medium-Speed Mode:** When the DTA bit is 0, internal interrupt signals specified as DMAC transfer sources are edge-detected.

In medium-speed mode, the DMAC operates on a medium-speed clock, while on-chip supporting modules operate on a high-speed clock. Consequently, if the period in which the relevant interrupt source is cleared by the CPU, DTC, or another DMAC channel, and the next interrupt is generated, is less than one state with respect to the DMAC clock (bus master clock), edge detection may not be possible and the interrupt may be ignored.

Also, in medium-speed mode,  $\overline{\text{DREQ}}$  pin sampling is performed on the rising edge of the medium-speed clock.

**Write Data Buffer Function:** When the WDBE bit of BCRL in the bus controller is set to 1, enabling the write data buffer function, dual address transfer external write cycles or single address transfers and internal accesses (on-chip memory or internal I/O registers) are executed in parallel.

**(a) Write Data Buffer Function and DMAC Register Setting**

If the setting of  $\overline{\text{DREQ}}$  is changed during execution of an external access by means of the write data buffer function, the external access may not be performed normally. The register that controls external accesses should only be manipulated when external reads, etc., are used with DMAC operation disabled, and the operation is not performed in parallel with external access.

**(b) Write Data Buffer Function and DMAC Operation Timing**

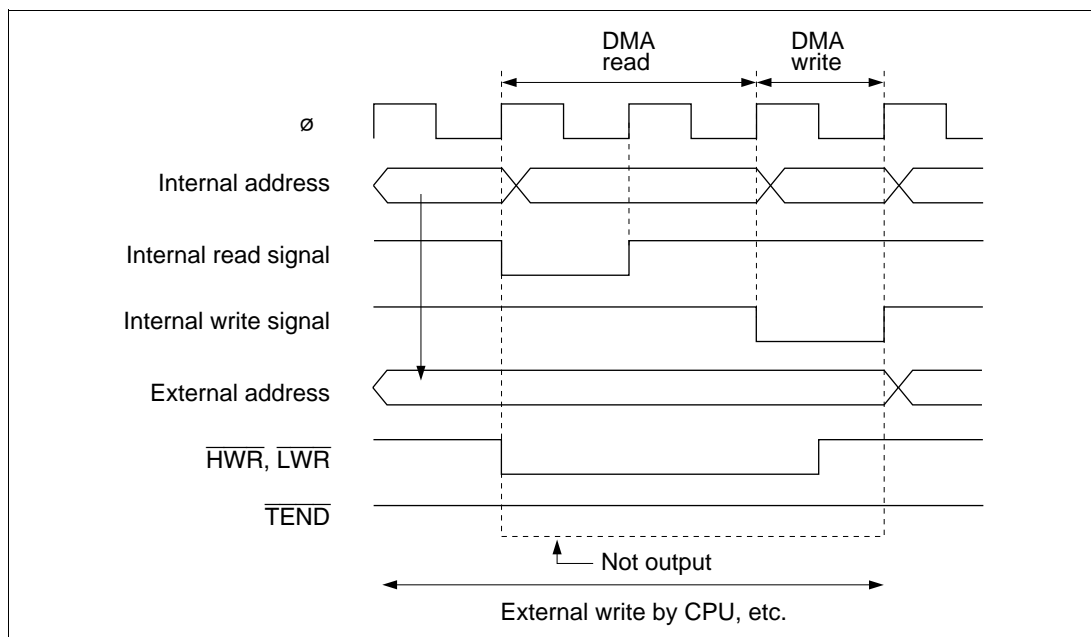
The DMAC can start its next operation during external access using the write data buffer function. Consequently, the  $\overline{\text{DREQ}}$  pin sampling timing,  $\overline{\text{TEND}}$  output timing, etc., are different from the case in which the write data buffer function is disabled. Also, internal bus cycles maybe hidden, and not visible.

**(c) Write Data Buffer Function and  $\overline{\text{TEND}}$  Output**

A low level is not output from the  $\overline{\text{TEND}}$  pin if the bus cycle in which a low level is to be output from the  $\overline{\text{TEND}}$  pin is an internal bus cycle, and an external write cycle is executed in parallel with this cycle. Note, for example, that a low level may not be output from the  $\overline{\text{TEND}}$  pin if the write data buffer function is used when data transfer is performed between an internal I/O register and on-chip memory.

If at least one of the DMAC transfer addresses is an external address, a low level is output from the  $\overline{\text{TEND}}$  pin.

Figure 8-42 shows an example in which a low level is not output at the  $\overline{\text{TEND}}$  pin.



**Figure 8-42 Example in Which Low Level is Not Output at  $\overline{\text{TEND}}$  Pin**

**Activation by Falling Edge on  $\overline{\text{DREQ}}$  Pin:**  $\overline{\text{DREQ}}$  pin falling edge detection is performed in synchronization with DMAC internal operations. The operation is as follows:

- [1] Activation request wait state: Waits for detection of a low level on the  $\overline{\text{DREQ}}$  pin, and switches to [2].
- [2] Transfer wait state: Waits for DMAC data transfer to become possible, and switches to [3].
- [3] Activation request disabled state: Waits for detection of a high level on the  $\overline{\text{DREQ}}$  pin, and switches to [1].

After DMAC transfer is enabled, a transition is made to [1]. Thus, initial activation after transfer is enabled is performed by detection of a low level.

**Activation Source Acceptance:** At the start of activation source acceptance, a low level is detected in both  $\overline{\text{DREQ}}$  pin falling edge sensing and low level sensing. Similarly, in the case of an internal interrupt, the interrupt request is detected. Therefore, a request is accepted from an internal interrupt or  $\overline{\text{DREQ}}$  pin low level that occurs before execution of the DMABCRL write to enable transfer.

When the DMAC is activated, take any necessary steps to prevent an internal interrupt or  $\overline{\text{DREQ}}$  pin low level remaining from the end of the previous transfer, etc.

**Internal Interrupt after End of Transfer:** When the DTE bit is cleared to 0 by the end of transfer or an abort, the selected internal interrupt request will be sent to the CPU or DTC even if DTA is set to 1.

Also, if internal DMAC activation has already been initiated when operation is aborted, the transfer is executed but flag clearing is not performed for the selected internal interrupt even if DTA is set to 1.

An internal interrupt request following the end of transfer or an abort should be handled by the CPU as necessary.

**Channel Re-Setting:** To reactivate a number of channels when multiple channels are enabled, use exclusive handling of transfer end interrupts, and perform DMABCR control bit operations exclusively.

Note, in particular, that in cases where multiple interrupts are generated between reading and writing of DMABCR, and a DMABCR operation is performed during new interrupt handling, the DMABCR write data in the original interrupt handling routine will be incorrect, and the write may invalidate the results of the operations by the multiple interrupts. Ensure that overlapping DMABCR operations are not performed by multiple interrupts, and that there is no separation between read and write operations by the use of a bit-manipulation instruction.

Also, when the DTE and DTME bits are cleared by the DMAC or are written with 0, they must first be read while cleared to 0 before the CPU can write a 1 to them.

## Section 9 Data Transfer Controller (DTC)

(This function is not available in the H8S/2695)

### 9.1 Overview

The H8S/2633 Series includes a data transfer controller (DTC). The DTC can be activated by an interrupt or software, to transfer data.

#### 9.1.1 Features

The features of the DTC are:

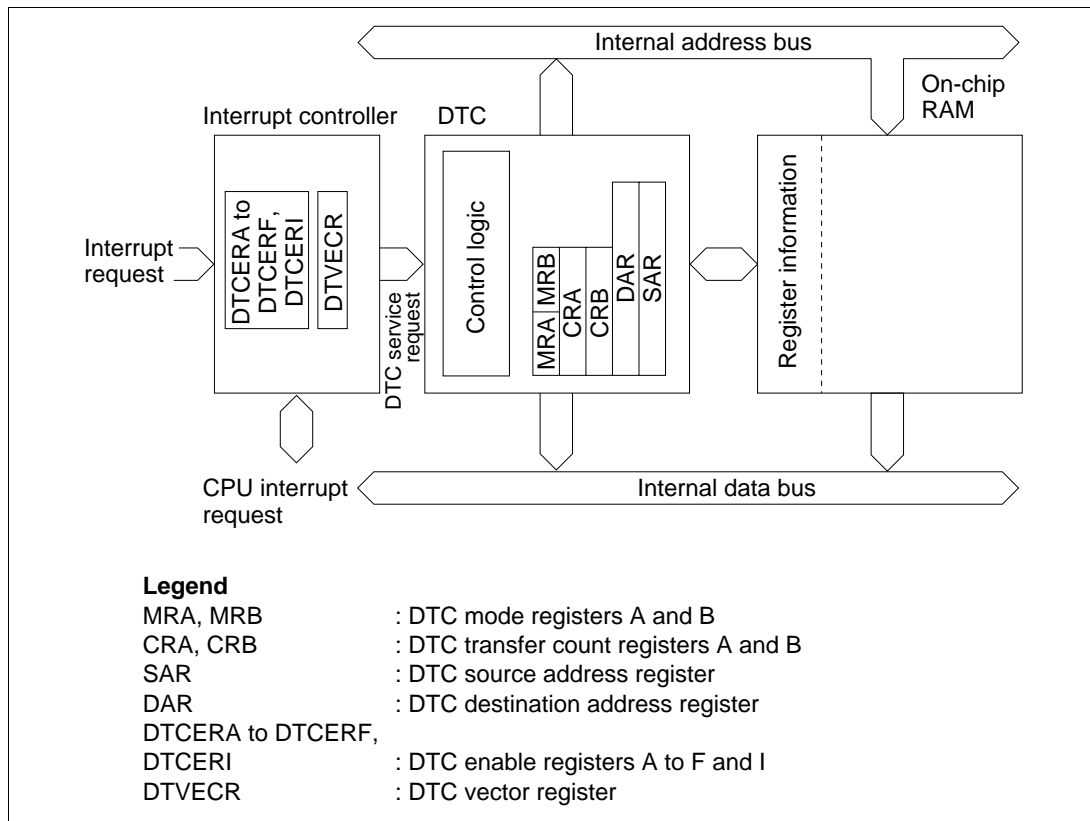
- Transfer possible over any number of channels
  - Transfer information is stored in memory
  - One activation source can trigger a number of data transfers (chain transfer)
- Wide range of transfer modes
  - Normal, repeat, and block transfer modes available
  - Incrementing, decrementing, and fixing of source and destination addresses can be selected
- Direct specification of 16-Mbyte address space possible
  - 24-bit transfer source and destination addresses can be specified
- Transfer can be set in byte or word units
- A CPU interrupt can be requested for the interrupt that activated the DTC
  - An interrupt request can be issued to the CPU after one data transfer ends
  - An interrupt request can be issued to the CPU after the specified data transfers have completely ended
- Activation by software is possible
- Module stop mode can be set
  - The initial setting enables DTC registers to be accessed. DTC operation is halted by setting module stop mode

### 9.1.2 Block Diagram

Figure 9-1 shows a block diagram of the DTC.

The DTC's register information is stored in the on-chip RAM\*. A 32-bit bus connects the DTC to the on-chip RAM (1 kbyte), enabling 32-bit/1-state reading and writing of the DTC register information.

Note: \* When the DTC is used, the RAME bit in SYSCR must be set to 1.



**Figure 9-1 Block Diagram of DTC**



### 9.1.3 Register Configuration

Table 9-1 summarizes the DTC registers.

**Table 9-1 DTC Registers**

Name	Abbreviation	R/W	Initial Value	Address* <sup>1</sup>
DTC mode register A	MRA	—* <sup>2</sup>	Undefined	—* <sup>3</sup>
DTC mode register B	MRB	—* <sup>2</sup>	Undefined	—* <sup>3</sup>
DTC source address register	SAR	—* <sup>2</sup>	Undefined	—* <sup>3</sup>
DTC destination address register	DAR	—* <sup>2</sup>	Undefined	—* <sup>3</sup>
DTC transfer count register A	CRA	—* <sup>2</sup>	Undefined	—* <sup>3</sup>
DTC transfer count register B	CRB	—* <sup>2</sup>	Undefined	—* <sup>3</sup>
DTC enable registers	DT CER	R/W	H'00	H'FE16 to H'FE1E
DTC vector register	DTVECR	R/W	H'00	H'FE1F
Module stop control register	MSTPCRA	R/W	H'3F	H'FDE8

Notes: \*1 Lower 16 bits of the address.

\*2 Registers within the DTC cannot be read or written to directly.

\*3 Register information is located in on-chip RAM addresses H'EBC0 to H'EFBF. It cannot be located in external memory space. When the DTC is used, do not clear the RAME bit in SYSCR to 0.

## 9.2 Register Descriptions

### 9.2.1 DTC Mode Register A (MRA)

Bit	:	7	6	5	4	3	2	1	0
		SM1	SM0	DM1	DM0	MD1	MD0	DTS	Sz
Initial value	:	Unde- fined	Unde- fined	Unde- fined	Unde- fined	Unde- fined	Unde- fined	Unde- fined	Unde- fined
R/W	:	—	—	—	—	—	—	—	—

MRA is an 8-bit register that controls the DTC operating mode.

**Bits 7 and 6—Source Address Mode 1 and 0 (SM1, SM0):** These bits specify whether SAR is to be incremented, decremented, or left fixed after a data transfer.

Bit 7	Bit 6	Description
0	—	SAR is fixed
1	0	SAR is incremented after a transfer (by +1 when Sz = 0; by +2 when Sz = 1)
	1	SAR is decremented after a transfer (by -1 when Sz = 0; by -2 when Sz = 1)

**Bits 5 and 4—Destination Address Mode 1 and 0 (DM1, DM0):** These bits specify whether DAR is to be incremented, decremented, or left fixed after a data transfer.

Bit 5	Bit 4	Description
0	—	DAR is fixed
1	0	DAR is incremented after a transfer (by +1 when Sz = 0; by +2 when Sz = 1)
	1	DAR is decremented after a transfer (by -1 when Sz = 0; by -2 when Sz = 1)

**Bits 3 and 2—DTC Mode (MD1, MD0):** These bits specify the DTC transfer mode.

<b>Bit 3</b>		<b>Bit 2</b>	<b>Description</b>
<b>MD1</b>	<b>MD0</b>		
0	0	Normal mode	
	1	Repeat mode	
1	0	Block transfer mode	
	1	—	

**Bit 1—DTC Transfer Mode Select (DTS):** Specifies whether the source side or the destination side is set to be a repeat area or block area, in repeat mode or block transfer mode.

<b>Bit 1</b>	<b>Description</b>
<b>DTS</b>	
0	Destination side is repeat area or block area
1	Source side is repeat area or block area

**Bit 0—DTC Data Transfer Size (Sz):** Specifies the size of data to be transferred.

<b>Bit 0</b>	<b>Description</b>
<b>Sz</b>	
0	Byte-size transfer
1	Word-size transfer

### 9.2.2 DTC Mode Register B (MRB)

Bit	:	7	6	5	4	3	2	1	0
		CHNE	DISEL	—	—	—	—	—	—
Initial value:		Unde- fined	Unde- fined	Unde- fined	Unde- fined	Unde- fined	Unde- fined	Unde- fined	Unde- fined
R/W	:	—	—	—	—	—	—	—	—

MRB is an 8-bit register that controls the DTC operating mode.

**Bit 7—DTC Chain Transfer Enable (CHNE):** Specifies chain transfer. With chain transfer, a number of data transfers can be performed consecutively in response to a single transfer request.

In data transfer with CHNE set to 1, determination of the end of the specified number of transfers, clearing of the interrupt source flag, and clearing of DTCER is not performed.

#### Bit 7

CHNE	Description
0	End of DTC data transfer (activation waiting state is entered)
1	DTC chain transfer (new register information is read, then data is transferred)

**Bit 6—DTC Interrupt Select (DISEL):** Specifies whether interrupt requests to the CPU are disabled or enabled after a data transfer.

#### Bit 6

DISEL	Description
0	After a data transfer ends, the CPU interrupt is disabled unless the transfer counter is 0 (the DTC clears the interrupt source flag of the activating interrupt to 0)
1	After a data transfer ends, the CPU interrupt is enabled (the DTC does not clear the interrupt source flag of the activating interrupt to 0)

**Bits 5 to 0—Reserved:** These bits have no effect on DTC operation in the H8S/2633 Series, and should always be written with 0.

### 9.2.3 DTC Source Address Register (SAR)

Bit	:	23	22	21	20	19	---	4	3	2	1	0
							---					
Initial value:		Unde-	Unde-	Unde-	Unde-	Unde-	---	Unde-	Unde-	Unde-	Unde-	Unde-
		fin-	fin-	fin-	fin-	fin-		fin-	fin-	fin-	fin-	fin-
R/W	:	—	—	—	—	—	---	—	—	—	—	—

SAR is a 24-bit register that designates the source address of data to be transferred by the DTC. For word-size transfer, specify an even source address.

### 9.2.4 DTC Destination Address Register (DAR)

Bit	:	23	22	21	20	19	---	4	3	2	1	0
							---					
Initial value :		Unde-	Unde-	Unde-	Unde-	Unde-	---	Unde-	Unde-	Unde-	Unde-	Unde-
		fin-	fin-	fin-	fin-	fin-		fin-	fin-	fin-	fin-	fin-
R/W	:	—	—	—	—	—	---	—	—	—	—	—

DAR is a 24-bit register that designates the destination address of data to be transferred by the DTC. For word-size transfer, specify an even destination address.

### 9.2.5 DTC Transfer Count Register A (CRA)

Bit	:	15	14	13	12	11	10	9	8	7	6	5	4	3	2	1	0
Initial value:		Unde-	Unde-	Unde-	Unde-	Unde-	Unde-	Unde-	Unde-	Unde-	Unde-	Unde-	Unde-	Unde-	Unde-	Unde-	Unde-
		fin-	fin-	fin-	fin-	fin-	fin-	fin-	fin-	fin-	fin-	fin-	fin-	fin-	fin-	fin-	fin-
R/W	:	—	—	—	—	—	—	—	—	—	—	—	—	—	—	—	—

CRA is a 16-bit register that designates the number of times data is to be transferred by the DTC.

In normal mode, the entire CRA functions as a 16-bit transfer counter (1 to 65,536). It is decremented by 1 every time data is transferred, and transfer ends when the count reaches H'0000.

In repeat mode or block transfer mode, the CRA is divided into two parts: the upper 8 bits (CRAH) and the lower 8 bits (CRAL). CRAH holds the number of transfers while CRAL functions as an 8-bit transfer counter (1 to 256). CRAL is decremented by 1 every time data is transferred, and the contents of CRAH are sent when the count reaches H'00. This operation is repeated.

### 9.2.6 DTC Transfer Count Register B (CRB)

Bit	:	15	14	13	12	11	10	9	8	7	6	5	4	3	2	1	0
Initial value:		Unde-	Unde-	Unde-	Unde-	Unde-	Unde-	Unde-	Unde-	Unde-	Unde-	Unde-	Unde-	Unde-	Unde-	Unde-	Unde-
		fin-	fin-	fin-	fin-	fin-	fin-	fin-	fin-	fin-	fin-	fin-	fin-	fin-	fin-	fin-	fin-
R/W	:	—	—	—	—	—	—	—	—	—	—	—	—	—	—	—	—

CRB is a 16-bit register that designates the number of times data is to be transferred by the DTC in block transfer mode. It functions as a 16-bit transfer counter (1 to 65,536) that is decremented by 1 every time data is transferred, and transfer ends when the count reaches H'0000.

### 9.2.7 DTC Enable Registers (DTCER)

Bit	:	7	6	5	4	3	2	1	0
		DTCE7	DTCE6	DTCE5	DTCE4	DTCE3	DTCE2	DTCE1	DTCE0
Initial value:		0	0	0	0	0	0	0	0
R/W	:	R/W	R/W	R/W	R/W	R/W	R/W	R/W	R/W

The DTC enable registers comprise seven 8-bit readable/writable registers, DTCERA to DTCERF and DTCERI, with bits corresponding to the interrupt sources that can control enabling and disabling of DTC activation. These bits enable or disable DTC service for the corresponding interrupt sources.

The DTC enable registers are initialized to H'00 by a reset and in hardware standby mode.

#### Bit n—DTC Activation Enable (DTCEn)

Bit n		
DTCEn	Description	
0	DTC activation by this interrupt is disabled [Clearing conditions]	(Initial value)
	<ul style="list-style-type: none"> <li>• When the DISEL bit is 1 and the data transfer has ended</li> <li>• When the specified number of transfers have ended</li> </ul>	
1	DTC activation by this interrupt is enabled [Holding condition]	
	When the DISEL bit is 0 and the specified number of transfers have not ended	

(n = 7 to 0)

A DTCE bit can be set for each interrupt source that can activate the DTC. The correspondence between interrupt sources and DTCE bits is shown in table 9-4, together with the vector number generated for each interrupt controller.

For DTCE bit setting, use bit manipulation instructions such as BSET and BCLR for reading and writing. If all interrupts are masked, multiple activation sources can be set at one time by writing data after executing a dummy read on the relevant register.

### 9.2.8 DTC Vector Register (DTVECR)

Bit	:	7	6	5	4	3	2	1	0
		SWDTE	DTVEC6	DTVEC5	DTVEC4	DTVEC3	DTVEC2	DTVEC1	DTVEC0
Initial value:		0	0	0	0	0	0	0	0
R/W	:	R/(W)*1	R/W*2	R/W*2	R/W*2	R/W*2	R/W*2	R/W*2	R/W*2

- Notes: \*1 Only 1 can be written to the SWDTE bit.  
 \*2 Bits DTVEC6 to DTVEC0 can be written to when SWDTE = 0.

DTVECR is an 8-bit readable/writable register that enables or disables DTC activation by software, and sets a vector number for the software activation interrupt.

DTVECR is initialized to H'00 by a reset and in hardware standby mode.

**Bit 7—DTC Software Activation Enable (SWDTE):** Enables or disables DTC activation by software.

#### Bit 7

SWDTE	Description
0	DTC software activation is disabled (Initial value) [Clearing conditions] <ul style="list-style-type: none"> <li>When the DISEL bit is 0 and the specified number of transfers have not ended</li> <li>When 0 s written to the DISEL bit after a software-activated data transfer end interrupt (SWDTEND) request has been sent to the CPU</li> </ul>
1	DTC software activation is enabled [Holding conditions] <ul style="list-style-type: none"> <li>When the DISEL bit is 1 and data transfer has ended</li> <li>When the specified number of transfers have ended</li> <li>During data transfer due to software activation</li> </ul>

**Bits 6 to 0—DTC Software Activation Vectors 6 to 0 (DTVEC6 to DTVEC0):** These bits specify a vector number for DTC software activation.

The vector address is expressed as H'0400 + ((vector number) << 1). <<1 indicates a one-bit left-shift. For example, when DTVEC6 to DTVEC0 = H'10, the vector address is H'0420.

### 9.2.9 Module Stop Control Register A (MSTPCRA)

Bit	:	7	6	5	4	3	2	1	0
		MSTPA7	MSTPA6	MSTPA5	MSTPA4	MSTPA3	MSTPA2	MSTPA1	MSTPA0
Initial value	:	0	0	1	1	1	1	1	1
R/W	:	R/W	R/W	R/W	R/W	R/W	R/W	R/W	R/W

MSTPCRA is a 8-bit readable/writable register that performs module stop mode control.

When the MSTPA6 bit in MSTPCRA is set to 1, the DTC operation stops at the end of the bus cycle and a transition is made to module stop mode. However, 1 cannot be written in the MSTPA6 bit while the DTC is operating. For details, see section 24.5, Module Stop Mode.

MSTPCRA is initialized to H'3F by a power-on reset and in hardware standby mode. It is not initialized in manual reset and software standby mode.

**Bit 6—Module Stop (MSTPA6):** Specifies the DTC module stop mode.

#### Bit 6

MSTPA6	Description
0	DTC module stop mode cleared (Initial value)
1	DTC module stop mode set



## 9.3 Operation

### 9.3.1 Overview

When activated, the DTC reads register information that is already stored in memory and transfers data on the basis of that register information. After the data transfer, it writes updated register information back to memory. Pre-storage of register information in memory makes it possible to transfer data over any required number of channels. Setting the CHNE bit to 1 makes it possible to perform a number of transfers with a single activation.

Figure 9-2 shows a flowchart of DTC operation.

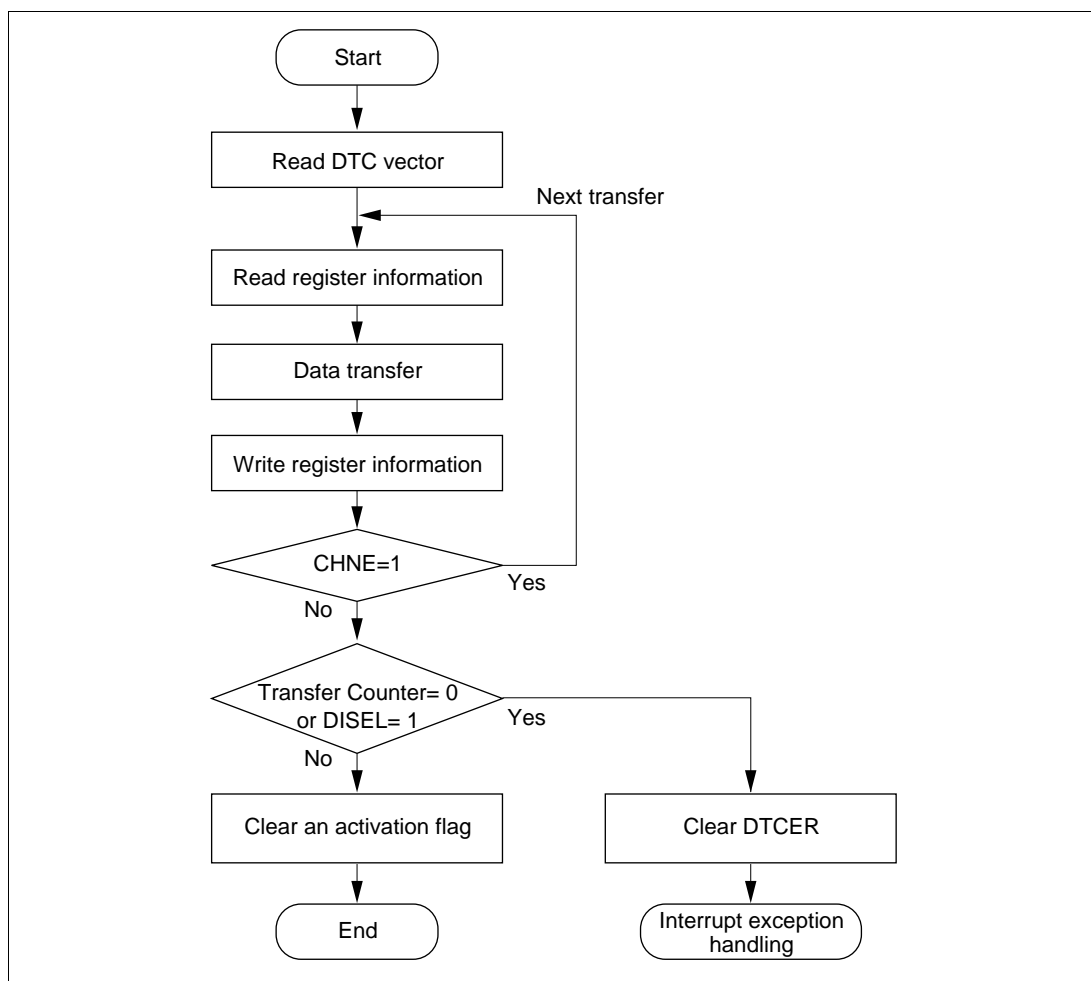


Figure 9-2 Flowchart of DTC Operation

The DTC transfer mode can be normal mode, repeat mode, or block transfer mode.

The 24-bit SAR designates the DTC transfer source address and the 24-bit DAR designates the transfer destination address. After each transfer, SAR and DAR are independently incremented, decremented, or left fixed.

Table 9-2 outlines the functions of the DTC.

**Table 9-2 DTC Functions**

Transfer Mode	Activation Source	Address Registers	
		Transfer Source	Transfer Destination
<ul style="list-style-type: none"> <li>• Normal mode               <ul style="list-style-type: none"> <li>— One transfer request transfers one byte or one word</li> <li>— Memory addresses are incremented or decremented by 1 or 2</li> <li>— Up to 65,536 transfers possible</li> </ul> </li> <li>• Repeat mode               <ul style="list-style-type: none"> <li>— One transfer request transfers one byte or one word</li> <li>— Memory addresses are incremented or decremented by 1 or 2</li> <li>— After the specified number of transfers (1 to 256), the initial state resumes and operation continues</li> </ul> </li> <li>• Block transfer mode               <ul style="list-style-type: none"> <li>— One transfer request transfers a block of the specified size</li> <li>— Block size is from 1 to 256 bytes or words</li> <li>— Up to 65,536 transfers possible</li> <li>— A block area can be designated at either the source or destination</li> </ul> </li> </ul>	<ul style="list-style-type: none"> <li>• IRQ</li> <li>• TPU TGI</li> <li>• 8-bit timer CMI</li> <li>• SCI TXI or RXI</li> <li>• A/D converter ADI</li> <li>• DMAC DEND</li> <li>• Software</li> </ul>	24 bits	24 bits

### 9.3.2 Activation Sources

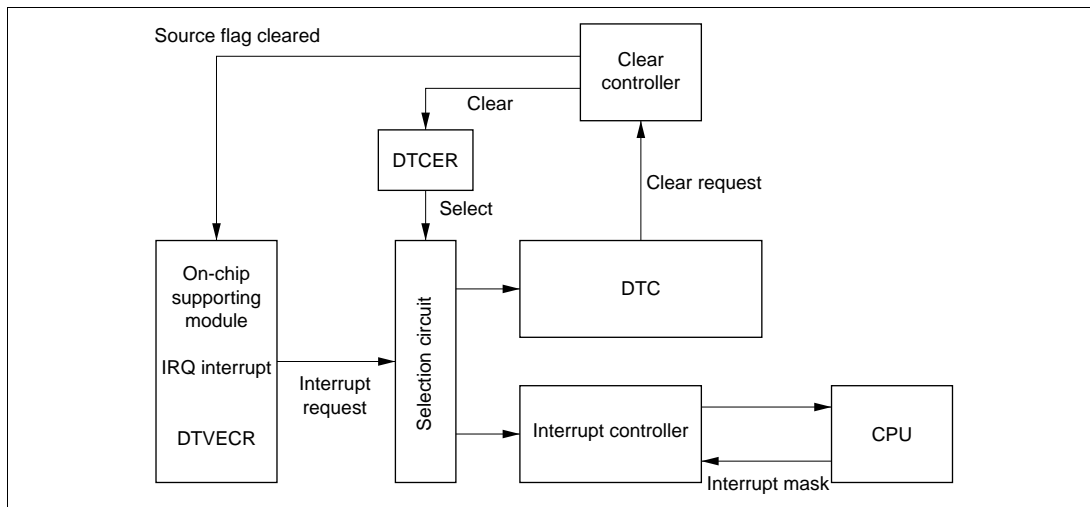
The DTC operates when activated by an interrupt or by a write to DTVECR by software. An interrupt request can be directed to the CPU or DTC, as designated by the corresponding DTCER bit. An interrupt becomes a DTC activation source when the corresponding bit is set to 1, and a CPU interrupt source when the bit is cleared to 0.

At the end of a data transfer (or the last consecutive transfer in the case of chain transfer), the activation source or corresponding DTCER bit is cleared. Table 9-3 shows activation source and DTCER clearance. The activation source flag, in the case of RXI0, for example, is the RDRF flag of SCIO.

**Table 9-3 Activation Source and DTCER Clearance**

Activation Source	When the DISEL Bit Is 0 and the Specified Number of Transfers Have Not Ended	When the DISEL Bit Is 1, or when the Specified Number of Transfers Have Ended
Software activation	The SWDTE bit is cleared to 0	The SWDTE bit remains set to 1 An interrupt is issued to the CPU
Interrupt activation	The corresponding DTCER bit remains set to 1 The activation source flag is cleared to 0	The corresponding DTCER bit is cleared to 0 The activation source flag remains set to 1 A request is issued to the CPU for the activation source interrupt

Figure 9-3 shows a block diagram of activation source control. For details see section 5, Interrupt Controller.



**Figure 9-3 Block Diagram of DTC Activation Source Control**

When an interrupt has been designated a DTC activation source, existing CPU mask level and interrupt controller priorities have no effect. If there is more than one activation source at the same time, the DTC operates in accordance with the default priorities.

### 9.3.3 DTC Vector Table

Figure 9-4 shows the correspondence between DTC vector addresses and register information.

Table 9-4 shows the correspondence between activation and vector addresses. When the DTC is activated by software, the vector address is obtained from:  $H'0400 + (DTVECR[6:0] \ll 1)$  (where  $\ll 1$  indicates a 1-bit left shift). For example, if DTVECR is H'10, the vector address is H'0420.

The DTC reads the start address of the register information from the vector address set for each activation source, and then reads the register information from that start address. The register information can be placed at predetermined addresses in the on-chip RAM. The start address of the register information should be an integral multiple of four.

The configuration of the vector address is the same in both normal\* and advanced modes, a 2-byte unit being used in both cases. These two bytes specify the lower bits of the address in the on-chip RAM.

Note: \* Not available in the H8S/2633 Series.

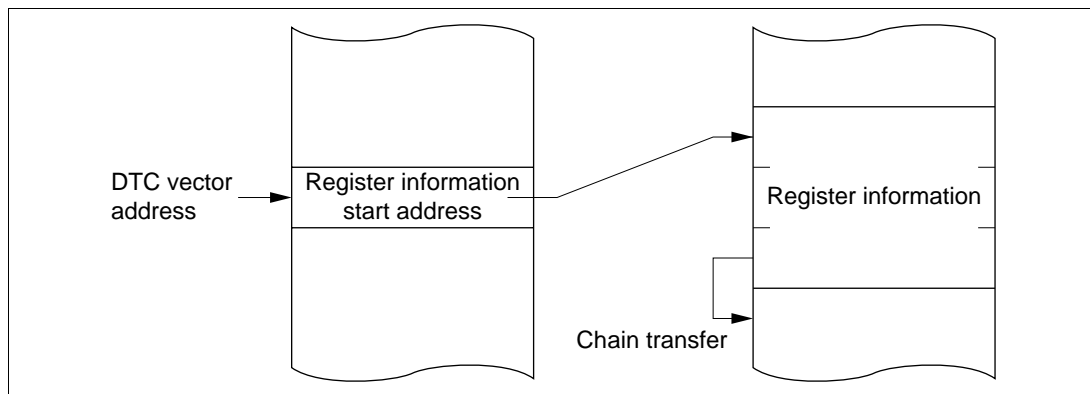


Figure 9-4 Correspondence between DTC Vector Address and Register Information

**Table 9-4 Interrupt Sources, DTC Vector Addresses, and Corresponding DTCEs**

<b>Interrupt Source</b>	<b>Origin of Interrupt Source</b>	<b>Vector Number</b>	<b>Vector Address</b>	<b>DTCE*</b>	<b>Priority</b>
Write to DTVECR	Software	DTVECR	H'0400+ (DTVECR [6:0] <<1)	—	High
IRQ0	External pin	16	H'0420	DTCEA7	↑ ↓ Low
IRQ1		17	H'0422	DTCEA6	
IRQ2		18	H'0424	DTCEA5	
IRQ3		19	H'0426	DTCEA4	
IRQ4		20	H'0428	DTCEA3	
IRQ5		21	H'042A	DTCEA2	
IRQ6		22	H'042C	DTCEA1	
IRQ7		23	H'042E	DTCEA0	
ADI (A/D conversion end)	A/D	28	H'0438	DTCEB6	
TGI0A (GR0A compare match/ input capture)	TPU channel 0	32	H'0440	DTCEB5	
TGI0B (GR0B compare match/ input capture)		33	H'0442	DTCEB4	
TGI0C (GR0C compare match/ input capture)		34	H'0444	DTCEB3	
TGI0D (GR0D compare match/ input capture)		35	H'0446	DTCEB2	
TGI1A (GR1A compare match/ input capture)	TPU channel 1	40	H'0450	DTCEB1	
TGI1B (GR1B compare match/ input capture)		41	H'0452	DTCEB0	
TGI2A (GR2A compare match/ input capture)	TPU channel 2	44	H'0458	DTCEC7	
TGI2B (GR2B compare match/ input capture)		45	H'045A	DTCEC6	

Interrupt Source	Origin of Interrupt Source	Vector Number	Vector Address	DTCE*	Priority
TGI3A (GR3A compare match/ input capture)	TPU channel 3	48	H'0460	DTCEC5	High ↑
TGI3B (GR3B compare match/ input capture)		49	H'0462	DTCEC4	
TGI3C (GR3C compare match/ input capture)		50	H'0464	DTCEC3	
TGI3D (GR3D compare match/ input capture)		51	H'0466	DTCEC2	
TGI4A (GR4A compare match/ input capture)	TPU channel 4	56	H'0470	DTCEC1	↓ Low
TGI4B (GR4B compare match/ input capture)		57	H'0472	DTCEC0	
TGI5A (GR5A compare match/ input capture)	TPU channel 5	60	H'0478	DTCED5	
TGI5B (GR5B compare match/ input capture)		61	H'047A	DTCED4	
CMIA0 (compare match A0)	8-bit timer channel 0	64	H'0480	DTCED3	
CMIB0 (compare match B0)		65	H'0482	DTCED2	
CMIA1 (compare match A1)	8-bit timer channel 1	68	H'0488	DTCED1	
CMIB1 (compare match B1)		69	H'048A	DTCED0	
DEND0A (channel 0/channel 0A transfer end)	DMAC	72	H'0490	DTCEE7	
DEND0B (channel 0B transfer end)		73	H'0492	DTCEE6	
DEND1A (channel 1/channel 1A transfer end)		74	H'0494	DTCEE5	
DEND1B (channel 1B transfer end)		75	H'0496	DTCEE4	
RXI0 (reception complete 0)	SCI channel 0	81	H'04A2	DTCEE3	
TXI0 (transmit data empty 0)		82	H'04A4	DTCEE2	
RXI1 (reception complete 1)	SCI channel 1	85	H'04AA	DTCEE1	
TXI1 (transmit data empty 1)		86	H'04AC	DTCEE0	
RXI2 (reception complete 2)	SCI channel 2	89	H'04B2	DTCEF7	
TXI2 (transmit data empty 2)		90	H'04B4	DTCEF6	

Interrupt Source	Origin of Interrupt Source	Vector Number	Vector Address	DTCE*	Priority
CMIA2 (compare match A2)	8-bit timer channel 2	92	H'04B8	DTCEF5	High ↑          ↓ Low
CMIB2 (compare match B2)	channel 2	93	H'04BA	DTCEF4	
CMIA3 (compare match A3)	8-bit timer channel 3	96	H'04C0	DTCEF3	
CMIB3 (compare match B3)	channel 3	97	H'04C2	DTCEF2	
IIC10 (1-byte transmit/reception complete)	IIC channel 0 (option)	100	H'04C8	DTCEF1	
IIC11 (1-byte transmit/reception complete)	IIC channel 1 (option)	102	H'04CC	DTCEF0	
RXI3 (reception complete 3)	SCI channel 3	121	H'04F2	DTCEI7	
TXI3 (transmit data empty 3)		122	H'04F4	DTCEI6	
RXI4 (reception complete 4)	SCI channel 4	125	H'04FA	DTCEI5	
TXI4 (transmit data empty 4)		126	H'04FC	DTCEI4	

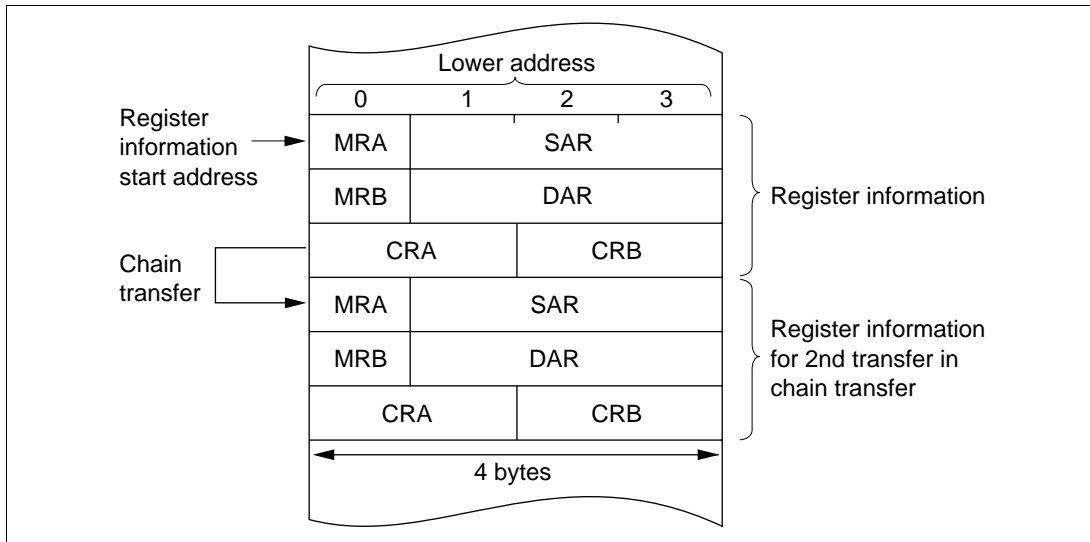
Note: \* DTCE bits with no corresponding interrupt are reserved, and should be written with 0.

### 9.3.4 Location of Register Information in Address Space

Figure 9-5 shows how the register information should be located in the address space.

Locate the MRA, SAR, MRB, DAR, CRA, and CRB registers, in that order, from the start address of the register information (contents of the vector address). In the case of chain transfer, register information should be located in consecutive areas.

Locate the register information in the on-chip RAM (addresses: H'FFEBC0 to H'FFEFBF).



**Figure 9-5 Location of Register Information in Address Space**



### 9.3.5 Normal Mode

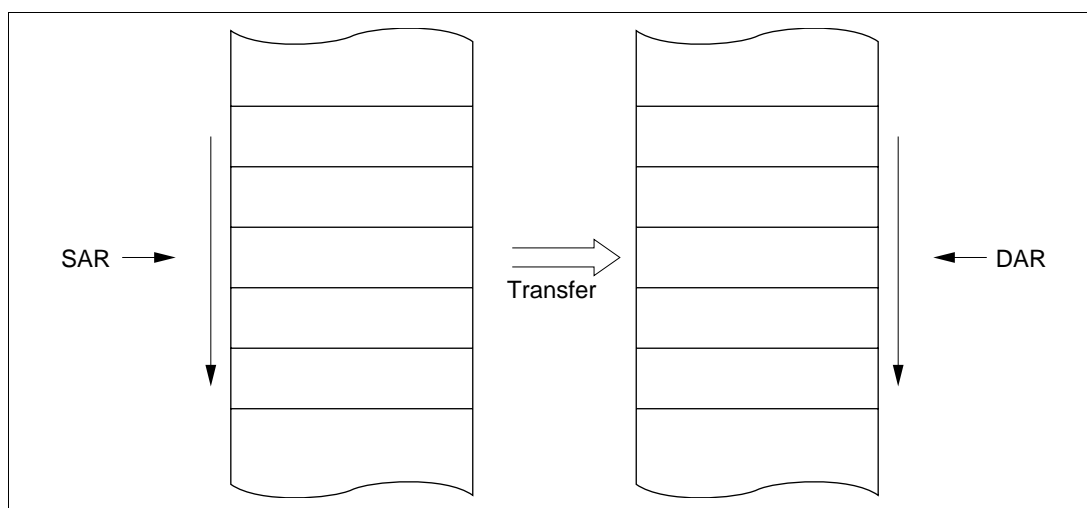
In normal mode, one operation transfers one byte or one word of data.

From 1 to 65,536 transfers can be specified. Once the specified number of transfers have ended, a CPU interrupt can be requested.

Table 9-5 lists the register information in normal mode and figure 9-6 shows memory mapping in normal mode.

**Table 9-5 Register Information in Normal Mode**

Name	Abbreviation	Function
DTC source address register	SAR	Designates source address
DTC destination address register	DAR	Designates destination address
DTC transfer count register A	CRA	Designates transfer count
DTC transfer count register B	CRB	Not used



**Figure 9-6 Memory Mapping in Normal Mode**

### 9.3.6 Repeat Mode

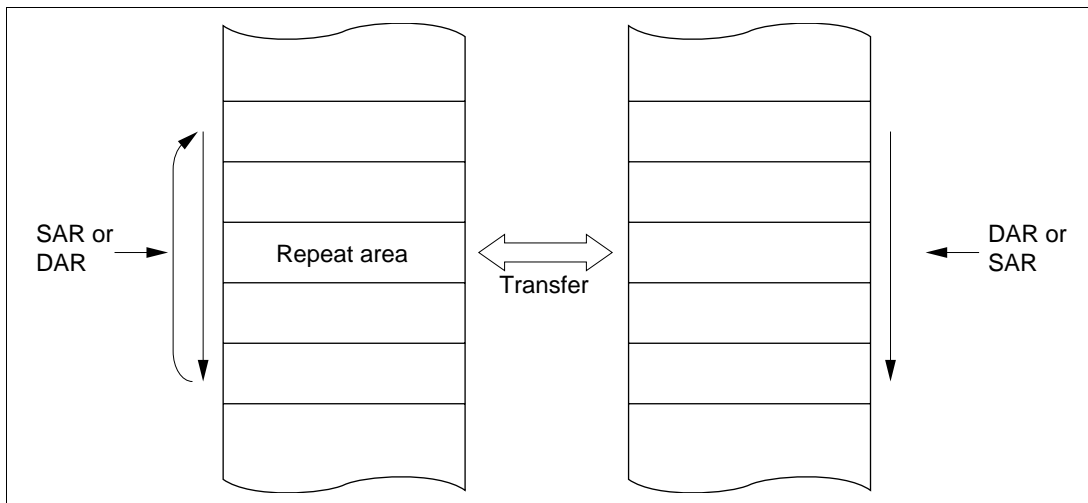
In repeat mode, one operation transfers one byte or one word of data.

From 1 to 256 transfers can be specified. Once the specified number of transfers have ended, the initial state of the transfer counter and the address register specified as the repeat area is restored, and transfer is repeated. In repeat mode the transfer counter value does not reach H'00, and therefore CPU interrupts cannot be requested when DISEL = 0.

Table 9-6 lists the register information in repeat mode and figure 9-7 shows memory mapping in repeat mode.

**Table 9-6 Register Information in Repeat Mode**

Name	Abbreviation	Function
DTC source address register	SAR	Designates source address
DTC destination address register	DAR	Designates destination address
DTC transfer count register AH	CRAH	Holds number of transfers
DTC transfer count register AL	CRAL	Designates transfer count
DTC transfer count register B	CRB	Not used



**Figure 9-7 Memory Mapping in Repeat Mode**

### 9.3.7 Block Transfer Mode

In block transfer mode, one operation transfers one block of data. Either the transfer source or the transfer destination is designated as a block area.

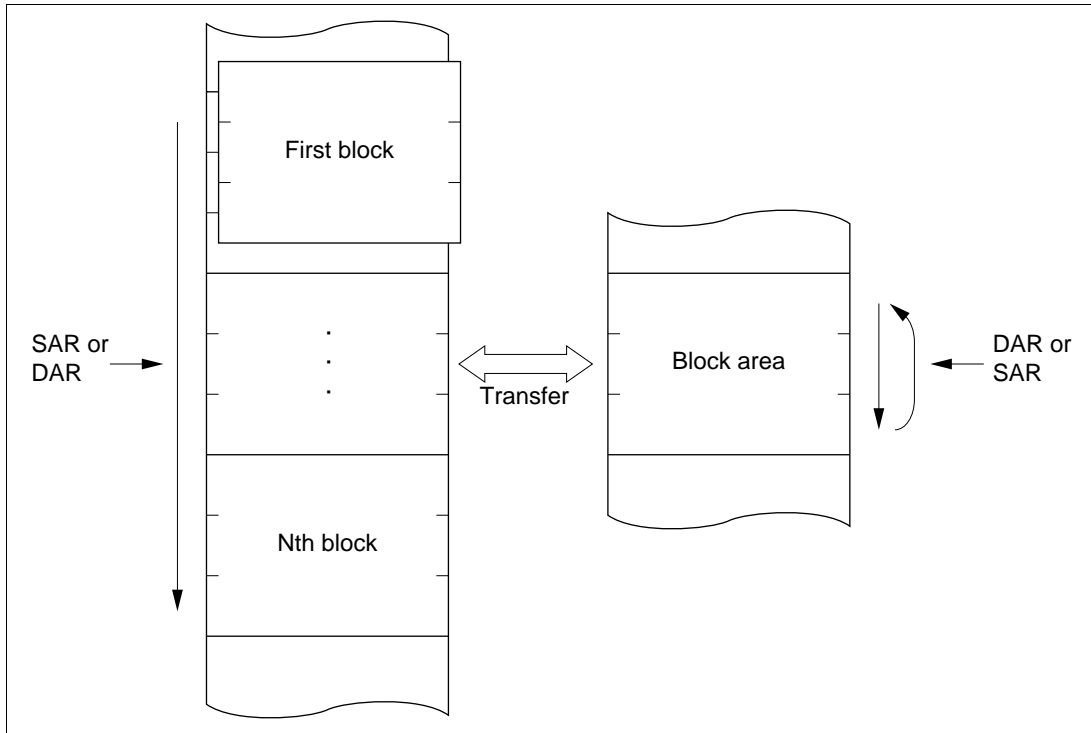
The block size is 1 to 256. When the transfer of one block ends, the initial state of the block size counter and the address register specified as the block area is restored. The other address register is then incremented, decremented, or left fixed.

From 1 to 65,536 transfers can be specified. Once the specified number of transfers have ended, a CPU interrupt is requested.

Table 9-7 lists the register information in block transfer mode and figure 9-8 shows memory mapping in block transfer mode.

**Table 9-7 Register Information in Block Transfer Mode**

<b>Name</b>	<b>Abbreviation</b>	<b>Function</b>
DTC source address register	SAR	Designates source address
DTC destination address register	DAR	Designates destination address
DTC transfer count register AH	CRAH	Holds block size
DTC transfer count register AL	CRAL	Designates block size count
DTC transfer count register B	CRB	Transfer count

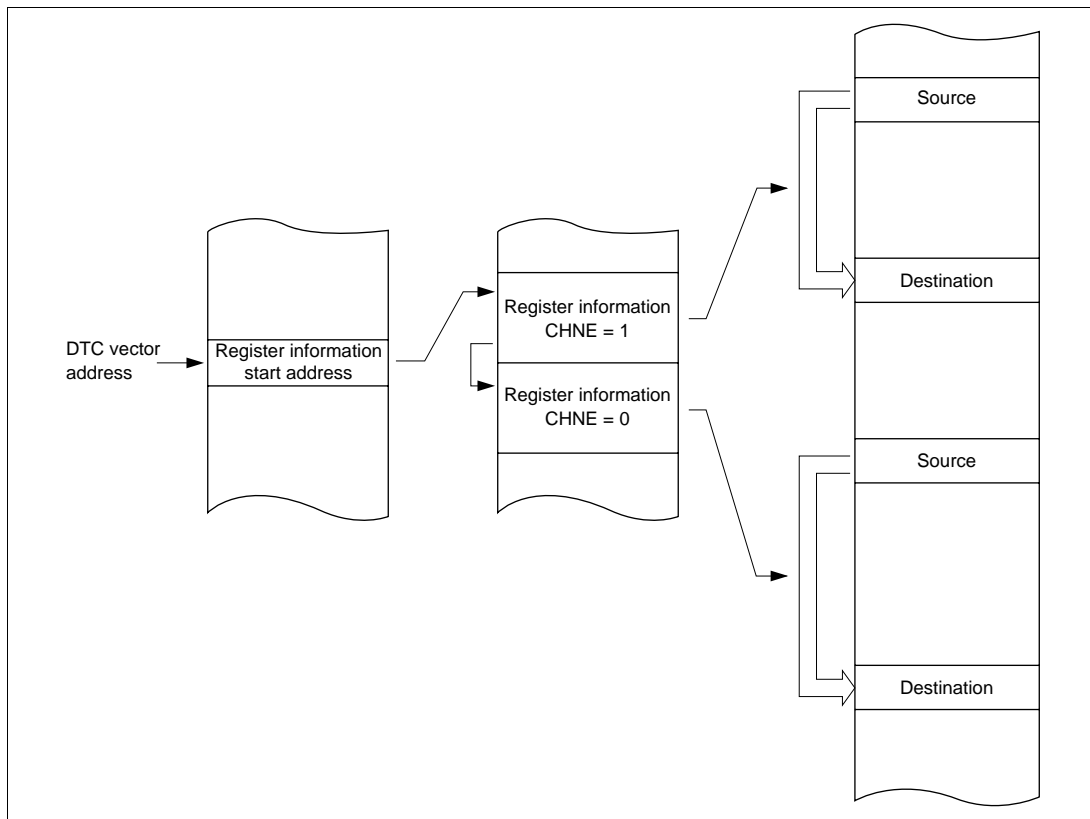


**Figure 9-8 Memory Mapping in Block Transfer Mode**

### 9.3.8 Chain Transfer

Setting the CHNE bit to 1 enables a number of data transfers to be performed consecutively in response to a single transfer request. SAR, DAR, CRA, CRB, MRA, and MRB, which define data transfers, can be set independently.

Figure 9-9 shows the memory map for chain transfer.

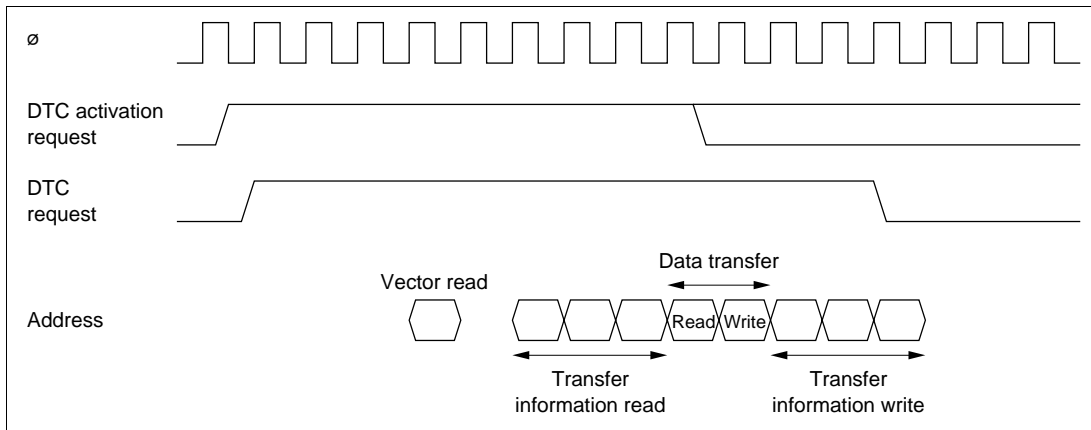


**Figure 9-9 Chain Transfer Memory Map**

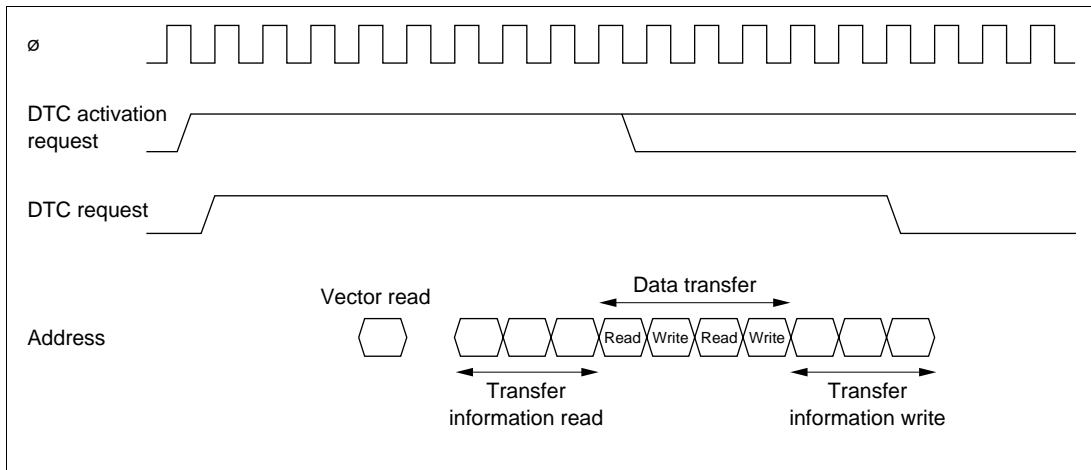
In the case of transfer with CHNE set to 1, an interrupt request to the CPU is not generated at the end of the specified number of transfers or by setting of the DISEL bit to 1, and the interrupt source flag for the activation source is not affected.

### 9.3.9 Operation Timing

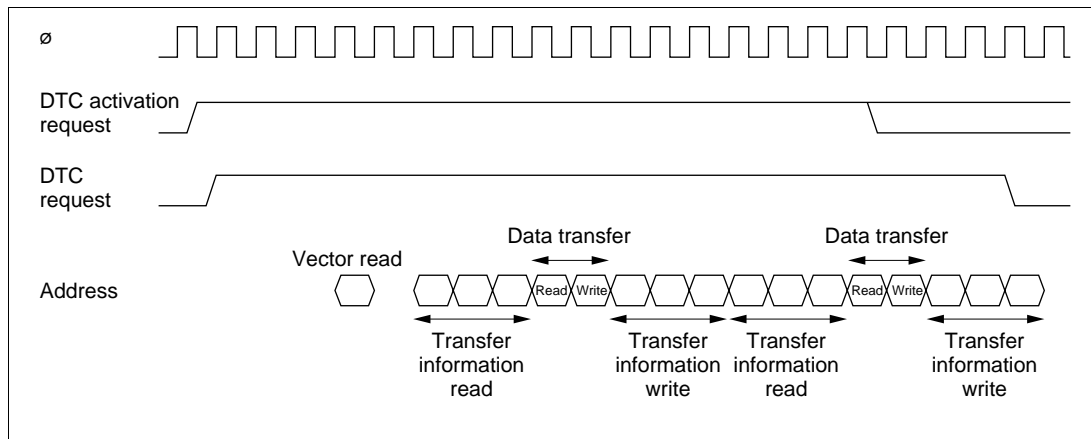
Figures 9-10 to 9-12 show an example of DTC operation timing.



**Figure 9-10 DTC Operation Timing (Example in Normal Mode or Repeat Mode)**



**Figure 9-11 DTC Operation Timing (Example of Block Transfer Mode, with Block Size of 2)**



**Figure 9-12 DTC Operation Timing (Example of Chain Transfer)**

### 9.3.10 Number of DTC Execution States

Table 9-8 lists execution statuses for a single DTC data transfer, and table 9-9 shows the number of states required for each execution status.

**Table 9-8 DTC Execution Statuses**

Mode	Vector Read I	Register Information Read/Write J	Data Read K	Data Write L	Internal Operations M
Normal	1	6	1	1	3
Repeat	1	6	1	1	3
Block transfer	1	6	N	N	3

N: Block size (initial setting of CRAH and CRAL)

**Table 9-9 Number of States Required for Each Execution Status**

Object to be Accessed			On-Chip RAM	On-Chip ROM	On-Chip I/O Registers		External Devices			
Bus width			32	16	8	16	8	16		
Access states			1	1	2	2	2	3	2	3
Execution status	Vector read	$S_I$	—	1	—	—	4	6+2m	2	3+m
	Register information read/write	$S_J$	1	—	—	—	—	—	—	—
	Byte data read	$S_K$	1	1	2	2	2	3+m	2	3+m
	Word data read	$S_K$	1	1	4	2	4	6+2m	2	3+m
	Byte data write	$S_L$	1	1	2	2	2	3+m	2	3+m
	Word data write	$S_L$	1	1	4	2	4	6+2m	2	3+m
Internal operation		$S_M$	1							

The number of execution states is calculated from the formula below. Note that  $\Sigma$  means the sum of all transfers activated by one activation event (the number in which the CHNE bit is set to 1, plus 1).

$$\text{Number of execution states} = I \cdot S_I + \Sigma (J \cdot S_J + K \cdot S_K + L \cdot S_L) + M \cdot S_M$$

For example, when the DTC vector address table is located in on-chip ROM, normal mode is set, and data is transferred from the on-chip ROM to an internal I/O register, the time required for the DTC operation is 13 states. The time from activation to the end of the data write is 10 states.



### 9.3.11 Procedures for Using DTC

**Activation by Interrupt:** The procedure for using the DTC with interrupt activation is as follows:

- [1] Set the MRA, MRB, SAR, DAR, CRA, and CRB register information in the on-chip RAM.
- [2] Set the start address of the register information in the DTC vector address.
- [3] Set the corresponding bit in DTCER to 1.
- [4] Set the enable bits for the interrupt sources to be used as the activation sources to 1. The DTC is activated when an interrupt used as an activation source is generated.
- [5] After the end of one data transfer, or after the specified number of data transfers have ended, the DTCE bit is cleared to 0 and a CPU interrupt is requested. If the DTC is to continue transferring data, set the DTCE bit to 1.

**Activation by Software:** The procedure for using the DTC with software activation is as follows:

- [1] Set the MRA, MRB, SAR, DAR, CRA, and CRB register information in the on-chip RAM.
- [2] Set the start address of the register information in the DTC vector address.
- [3] Check that the SWDTE bit is 0.
- [4] Write 1 to SWDTE bit and the vector number to DTVECR.
- [5] Check the vector number written to DTVECR.
- [6] After the end of one data transfer, if the DISEL bit is 0 and a CPU interrupt is not requested, the SWDTE bit is cleared to 0. If the DTC is to continue transferring data, set the SWDTE bit to 1. When the DISEL bit is 1, or after the specified number of data transfers have ended, the SWDTE bit is held at 1 and a CPU interrupt is requested.

### 9.3.12 Examples of Use of the DTC

#### (1) Normal Mode

An example is shown in which the DTC is used to receive 128 bytes of data via the SCI.

- [1] Set MRA to fixed source address (SM1 = SM0 = 0), incrementing destination address (DM1 = 1, DM0 = 0), normal mode (MD1 = MD0 = 0), and byte size (Sz = 0). The DTS bit can have any value. Set MRB for one data transfer by one interrupt (CHNE = 0, DISEL = 0). Set the SCI RDR address in SAR, the start address of the RAM area where the data will be received in DAR, and 128 (H'0080) in CRA. CRB can be set to any value.
- [2] Set the start address of the register information at the DTC vector address.
- [3] Set the corresponding bit in DTCER to 1.
- [4] Set the SCI to the appropriate receive mode. Set the RIE bit in SCR to 1 to enable the reception complete (RXI) interrupt. Since the generation of a receive error during the SCI reception operation will disable subsequent reception, the CPU should be enabled to accept receive error interrupts.
- [5] Each time reception of one byte of data ends on the SCI, the RDRF flag in SSR is set to 1, an RXI interrupt is generated, and the DTC is activated. The receive data is transferred from RDR to RAM by the DTC. DAR is incremented and CRA is decremented. The RDRF flag is automatically cleared to 0.
- [6] When CRA becomes 0 after the 128 data transfers have ended, the RDRF flag is held at 1, the DTCE bit is cleared to 0, and an RXI interrupt request is sent to the CPU. The interrupt handling routine should perform wrap-up processing.

## (2) Chain Transfer

An example of DTC chain transfer is shown in which pulse output is performed using the PPG. Chain transfer can be used to perform pulse output data transfer and PPG output trigger cycle updating. Repeat mode transfer to the PPG's NDR is performed in the first half of the chain transfer, and normal mode transfer to the TPU's TGR in the second half. This is because clearing of the activation source and interrupt generation at the end of the specified number of transfers are restricted to the second half of the chain transfer (transfer when CHNE = 0).

- [1] Perform settings for transfer to the PPG's NDR. Set MRA to source address incrementing (SM1 = 1, SM0 = 0), fixed destination address (DM1 = DM0 = 0), repeat mode (MD1 = 0, MD0 = 1), and word size (Sz = 1). Set the source side as a repeat area (DTS = 1). Set MRB to chain mode (CHNE = 1, DISEL = 0). Set the data table start address in SAR, the NDRH address in DAR, and the data table size in CRAH and CRAL. CRB can be set to any value.
- [2] Perform settings for transfer to the TPU's TGR. Set MRA to source address incrementing (SM1 = 1, SM0 = 0), fixed destination address (DM1 = DM0 = 0), normal mode (MD1 = MD0 = 0), and word size (Sz = 1). Set the data table start address in SAR, the TGRA address in DAR, and the data table size in CRA. CRB can be set to any value.
- [3] Locate the TPU transfer register information consecutively after the NDR transfer register information.
- [4] Set the start address of the NDR transfer register information to the DTC vector address.
- [5] Set the bit corresponding to TGIA in DTCCR to 1.
- [6] Set TGRA as an output compare register (output disabled) with TIOR, and enable the TGIA interrupt with TIER.
- [7] Set the initial output value in PODR, and the next output value in NDR. Set bits in DDR and NDER for which output is to be performed to 1. Using PCR, select the TPU compare match to be used as the output trigger.
- [8] Set the CST bit in TSTR to 1, and start the TCNT count operation.
- [9] Each time a TGRA compare match occurs, the next output value is transferred to NDR and the set value of the next output trigger period is transferred to TGRA. The activation source TGFA flag is cleared.
- [10] When the specified number of transfers are completed (the TPU transfer CRA value is 0), the TGFA flag is held at 1, the DTCE bit is cleared to 0, and a TGIA interrupt request is sent to the CPU. Termination processing should be performed in the interrupt handling routine.

### (3) Software Activation

An example is shown in which the DTC is used to transfer a block of 128 bytes of data by means of software activation. The transfer source address is H'1000 and the destination address is H'2000. The vector number is H'60, so the vector address is H'04C0.

- [1] Set MRA to incrementing source address (SM1 = 1, SM0 = 0), incrementing destination address (DM1 = 1, DM0 = 0), block transfer mode (MD1 = 1, MD0 = 0), and byte size (Sz = 0). The DTS bit can have any value. Set MRB for one block transfer by one interrupt (CHNE = 0). Set the transfer source address (H'1000) in SAR, the destination address (H'2000) in DAR, and 128 (H'8080) in CRA. Set 1 (H'0001) in CRB.
- [2] Set the start address of the register information at the DTC vector address (H'04C0).
- [3] Check that the SWDTE bit in DTVECR is 0. Check that there is currently no transfer activated by software.
- [4] Write 1 to the SWDTE bit and the vector number (H'60) to DTVECR. The write data is H'E0.
- [5] Read DTVECR again and check that it is set to the vector number (H'60). If it is not, this indicates that the write failed. This is presumably because an interrupt occurred between steps 3 and 4 and led to a different software activation. To activate this transfer, go back to step 3.
- [6] If the write was successful, the DTC is activated and a block of 128 bytes of data is transferred.
- [7] After the transfer, an SWDTEND interrupt occurs. The interrupt handling routine should clear the SWDTE bit to 0 and perform other wrap-up processing.

## 9.4 Interrupts

An interrupt request is issued to the CPU when the DTC finishes the specified number of data transfers, or a data transfer for which the DISEL bit was set to 1. In the case of interrupt activation, the interrupt set as the activation source is generated. These interrupts to the CPU are subject to CPU mask level and interrupt controller priority level control.

In the case of activation by software, a software activated data transfer end interrupt (SWDTEND) is generated.

When the DISEL bit is 1 and one data transfer has ended, or the specified number of transfers have ended, after data transfer ends, the SWDTE bit is held at 1 and an SWDTEND interrupt is generated. The interrupt handling routine should clear the SWDTE bit to 0.

When the DTC is activated by software, an SWDTEND interrupt is not generated during a data transfer wait or during data transfer even if the SWDTE bit is set to 1.

## 9.5 Usage Notes

**Module Stop:** When the MSTPA6 bit in MSTPCRA is set to 1, the DTC clock stops, and the DTC enters the module stop state. However, 1 cannot be written in the MSTPA6 bit while the DTC is operating.

**On-Chip RAM:** The MRA, MRB, SAR, DAR, CRA, and CRB registers are all located in on-chip RAM. When the DTC is used, the RAME bit in SYSCR must not be cleared to 0.

**DMAC Transfer End Interrupt:** When the DTC is activated with a DMAC transfer end interrupt, the DMAC's DTE bit is not controlled by the DTC regardless of the transfer counter and DISEL bit, and write data takes precedence. For this reason, there may be no interrupt generated by the CPU even if the DTC transfer counter is cleared to 0.

**DTCE Bit Setting:** For DTCE bit setting, use bit manipulation instructions such as BSET and BCLR. If all interrupts are masked, multiple activation sources can be set at one time by writing data after executing a dummy read on the relevant register.



## Section 10A I/O Ports (H8S/2633, H8S/2632, H8S/2631, H8S/2633R)

### 10A.1 Overview

The H8S/2633 Series has 10 I/O ports (ports 1, 3, 7 and A to G), and two input-only port (ports 4 and 9).

Table 10A-1 summarizes the port functions. The pins of each port also have other functions.

Each I/O port includes a data direction register (DDR) that controls input/output, a data register (DR) that stores output data, and a port register (PORT) used to read the pin states. The input-only ports do not have a DR or DDR register.

Ports A to E have a built-in pull-up MOS function, and in addition to DR and DDR, have a MOS input pull-up control register (PCR) to control the on/off state of MOS input pull-up.

Ports 3, and A to C include an open-drain control register (ODR) that controls the on/off state of the output buffer PMOS.

When ports 10 to 13, 70 to 73, and A to G are used as the output pins for expanded bus control signals, they can drive one TTL load plus a 50pF capacitance load. Those ports in other cases, and ports 14 to 17, 3, and 74 to 77, can drive one TTL load and a 30pF capacitance load. All I/O ports can drive Darlington transistors when set to output.

See Appendix C, I/O Port Block Diagrams, for a block diagram of each port.

**Table 10A-1 Port Functions**

Port	Description	Pins	Mode 4	Mode 5	Mode 6	Mode 7
Port 1	<ul style="list-style-type: none"> <li>• 8-bit I/O port</li> <li>• Schmitt-triggered input (P16, P14)</li> </ul>	P17/PO15/TIOCB2/ PWM3/TCLKD P16/PO14/TIOCA2/ PWM2/IRQ1 P15/PO13/TIOCB1/ TCLKC P14/PO12/TIOCA1/ IRQ0 P13/PO11/TIOCD0/ TCLKB/A23 P12/PO10/TIOCC0/ TCLKA/A22 P11/PO9/TIOCB0/ DACK1/A21 P10/PO8/TIOCA0/ DACK0/A20	8-bit I/O port also functioning as DMA controller output pins (DACK0, DACK1), TPU I/O pins (TCLKA, TCLKB, TCLKC, TCLKD, TIOCA0, TIOCB0, TIOCC0, TIOCD0, TIOCA1, TIOCB1, TIOCA2, TIOCB2), PPG output pins (PO15 to PO8), interrupt input pins (IRQ0, IRQ1), 14-bit PWM output pins (PWM2, PWM3), and address outputs (A20 to A23)			8-bit I/O port also functioning as DMA controller output pins (DACK0, DACK1), TPU I/O pins (TCLKA, TCLKB, TCLKC, TCLKD, TIOCA0, TIOCB0, TIOCC0, TIOCD0, TIOCA1, TIOCB1, TIOCA2, TIOCB2), PPG output pins (PO15 to PO8), interrupt input pins (IRQ0, IRQ1), and 14-bit PWM output pins (PWM2, PWM3)
Port 3	<ul style="list-style-type: none"> <li>• 8-bit I/O port</li> <li>• Open-drain output capability</li> <li>• Schmitt-triggered input (P35, P32)</li> </ul>	P37 /TxD4 P36/RxD4 P35/SCK1/SCK4/ SCL0/IRQ5 P34 /RxD1/SDA0 P33 /TxD1/SCL1 P32 /SCK0/SDA1/IRQ4 P31 /RxD0/IrRxD P30 /TxD0/IrTxD	8-bit I/O port also functioning as SCI (channel 0, 1, and 4) I/O pins (TxD0, RxD0, SCK0, IrTxD, IrRxD, TxD1, RxD1, SCK1, TxD4, RxD4, SCK4), interrupt input pins (IRQ4, IRQ5), and IIC (channel 0 and 1) I/O pins (SCL0, SDA0, SCL1, SDA1)			
Port 4	<ul style="list-style-type: none"> <li>• 8-bit input port</li> </ul>	P47 /AN7/DA1 P46 /AN6/DA0 P45 /AN5 P44 /AN4 P43 /AN3 P42 /AN2 P41 /AN1 P40/AN0	8-bit input port also functioning as A/D converter analog inputs (AN7 to AN0) and D/A converter analog outputs (DA1, DA0)			



Port	Description	Pins	Mode 4	Mode 5	Mode 6	Mode 7
Port 7	<ul style="list-style-type: none"> <li>8-bit I/O port</li> </ul>	P77/TxD3 P76/RxD3 P75/TMO3/SCK3 P74/TMO2/MRES P73/TMO1/TEND1/ CS7 P72/TMO0/TEND0/ CS6/SYNCI P71/TMRI23/TMCI23/ DREQ1/CS5 P70/TMRI01/TMCI01/ DREQ0/CS4	8-bit I/O port also functioning as 8-bit timer I/O pins (TMRI01, TMCI01, TMRI23, TMCI23, TMO0, TMO1, TMO2, TMO3), DMAC I/O pins (DREQ0, TEND0, DREQ1, TEND1), bus control output pins (CS4 to CS7), the IIC input pin (SYNCI), SCI I/O pins (SCK3, RxD3, TxD3), and the manual reset input pin (MRES)			8-bit I/O port also functioning as 8-bit timer I/O pins (TMRI01, TMCI01, TMRI23, TMCI23, TMO0, TMO1, TMO2, TMO3), DMAC I/O pins (DREQ0, TEND0, DREQ1, TEND1), the IIC input pin (SYNCI), SCI I/O pins (SCK3, RxD3, TxD3), and the manual reset input pin (MRES)
Port 9	<ul style="list-style-type: none"> <li>8-bit input port</li> </ul>	P97/AN15/DA3 P96/AN14/DA2 P95/AN13 P94/AN12 P93/AN11 P92/AN10 P91/AN9 P90/AN8	8-bit input port also functioning as A/D converter analog inputs (AN15 to AN8) and D/A converter analog outputs (DA3, DA2)			
Port A	<ul style="list-style-type: none"> <li>4-bit I/O port</li> <li>Built-in MOS input pull-up</li> <li>Open-drain output capability</li> </ul>	PA3/A19/SCK2 PA2/A18/RxD2 PA1/A17/TxD2 PA0/A16	4-bit I/O port also functioning as SCI (channel 2) I/O pins (TxD2, RxD2, SCK2) and address outputs (A19 to A16)			4-bit I/O port also functioning as SCI (channel 2) I/O pins (TxD2, RxD2, SCK2)

Port	Description	Pins	Mode 4	Mode 5	Mode 6	Mode 7
Port B	<ul style="list-style-type: none"> <li>• 8-bit I/O port</li> <li>• Built-in MOS input pull-up</li> <li>• Open-drain output capability</li> </ul>	PB7/A15/TIOCB5 PB6/A14/TIOCA5 PB5/A13/TIOCB4 PB4/A12/TIOCA4 PB3/A11/TIOCD3 PB2/A10/TIOCC3 PB1/A9/TIOCB3 PB0/A8/TIOCA3	8-bit I/O port also functioning as TPU I/O pins (TIOCB5, TIOCA5, TIOCB4, TIOCA4, TIOCD3, TIOCC3, TIOCB3, TIOCA3) and address outputs (A15 to A8)			8-bit I/O port also functioning as TPU I/O pins (TIOCB5, TIOCA5, TIOCB4, TIOCA4, TIOCD3, TIOCC3, TIOCB3, TIOCA3)
Port C	<ul style="list-style-type: none"> <li>• 8-bit I/O port</li> <li>• Built-in MOS input pull-up</li> <li>• Open-drain output capability</li> </ul>	PC7/A7/PWM1 PC6/A6/PWM0 PC5/A5 PC4/A4 PC3/A3 PC2/A2 PC1/A1 PC0 /A0	8-bit I/O port also functioning as 14-bit PWM (channel 1 and 0) output pins (PWM1, PWM0) and address outputs (A7 to A0)			8-bit I/O port also functioning as 14-bit PWM (channel 1 and 0) output pins (PWM1, PWM0)
Port D	<ul style="list-style-type: none"> <li>• 8-bit I/O port</li> <li>• Built-in MOS input pull-up</li> </ul>	PD7 /D15 PD6/D14 PD5/D13 PD4/D12 PD3/D11 PD2/D10 PD1/D9 PD0 /D8	Data bus input/output			I/O port
Port E	<ul style="list-style-type: none"> <li>• 8-bit I/O port</li> <li>• Built-in MOS input pull-up</li> </ul>	PE7/D7 PE6/D6 PE5/D5 PE4/D4 PE3/D3 PE2/D2 PE1/D1 PE0 /D0	In 8-bit-bus mode: I/O port In 16-bit-bus mode: data bus input/output			I/O port

Port	Description	Pins	Mode 4	Mode 5	Mode 6	Mode 7
Port F	• 8-bit I/O port	PF7 / $\emptyset$	When DDR = 0: input port When DDR = 1 (after reset): $\emptyset$ output			When DDR = 0 (after reset): input port When DDR = 1: $\emptyset$ output
		PF6 / $\overline{\text{AS}}$ / $\overline{\text{LCAS}}$ PF5 / $\overline{\text{RD}}$ PF4 / $\overline{\text{HWR}}$ PF3/ $\overline{\text{LWR}}$ / $\overline{\text{ADTRG}}$ / $\overline{\text{IRQ3}}$	$\overline{\text{RD}}$ , $\overline{\text{HWR}}$ , $\overline{\text{LWR}}$ outputs $\overline{\text{ADTRG}}$ , $\overline{\text{IRQ3}}$ input When LCASS = 0: $\overline{\text{AS}}$ output When RMTS2 to RMTS0 = B'001 to B'011, CW2 = 0, and LCASS = 1: $\overline{\text{LCAS}}$ output			I/O port $\overline{\text{ADTRG}}$ , $\overline{\text{IRQ3}}$ input
		PF2/ $\overline{\text{LCAS}}$ / $\overline{\text{WAIT}}$ / $\overline{\text{BREQO}}$	When WAITE = 0 and BREQOE = 0 (after reset): I/O port When WAITE = 1 and BREQOE = 0: $\overline{\text{WAIT}}$ input When WAITE = 0 and BREQOE = 1: $\overline{\text{BREQO}}$ input When RMTS2 to RMTS0 = B'001 to B'011, CW2 = 0, and LCASS = 0: $\overline{\text{LCAS}}$ output			I/O port
		PF1/ $\overline{\text{BACK}}$ / $\overline{\text{BUZZ}}$ PF0/ $\overline{\text{BREQ}}$ / $\overline{\text{IRQ2}}$	When BRLE = 0 (after reset): I/O port When BRLE = 1: $\overline{\text{BREQ}}$ input, $\overline{\text{BACK}}$ output $\overline{\text{BUZZ}}$ output, $\overline{\text{IRQ2}}$ input			$\overline{\text{BUZZ}}$ output $\overline{\text{IRQ2}}$ input I/O port
Port G	• 5-bit I/O port	PG4 / $\overline{\text{CS0}}$	When DDR = 0*1: input port When DDR = 1*2: $\overline{\text{CS0}}$ output			I/O port
		PG3 / $\overline{\text{CS1}}$ PG2 / $\overline{\text{CS2}}$ PG1 / $\overline{\text{CS3}}$ / $\overline{\text{OE}}$ / $\overline{\text{IRQ7}}$	When DDR = 0 (after reset): input port When DDR = 1: $\overline{\text{CS1}}$ , $\overline{\text{CS2}}$ , $\overline{\text{CS3}}$ outputs $\overline{\text{OE}}$ output, $\overline{\text{IRQ7}}$ input			I/O port, $\overline{\text{IRQ7}}$ input
		PG0 / $\overline{\text{CAS}}$ / $\overline{\text{IRQ6}}$	DRAM space set: $\overline{\text{CAS}}$ output Otherwise (after reset): I/O port $\overline{\text{IRQ6}}$ input			I/O port, $\overline{\text{IRQ6}}$ input

Notes: \*1 After a reset in mode 6

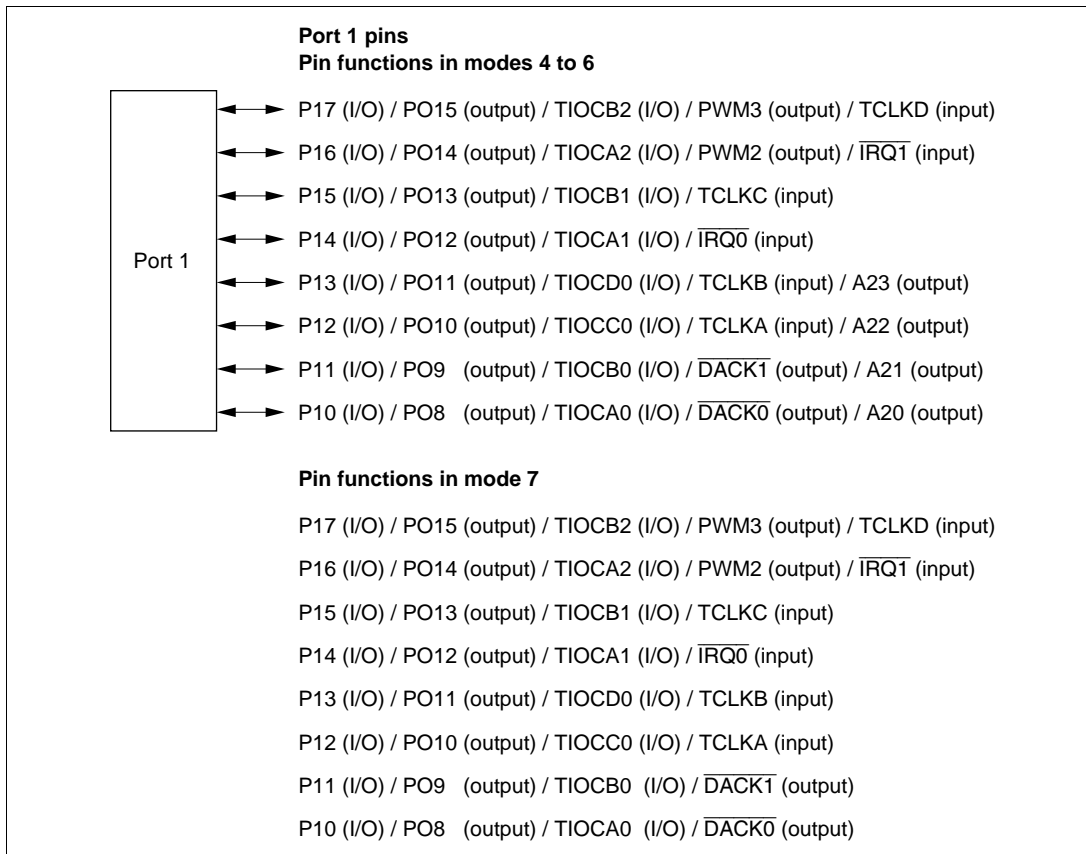
\*2 After a reset in modes 4 or 5

## 10A.2 Port 1

### 10A.2.1 Overview

Port 1 is an 8-bit I/O port. Port 1 pins also function as PPG output pins (PO15 to PO8), TPU I/O pins (TCLKA, TCLKB, TCLKC, TCLKD, TIOCA0, TIOCB0, TIOCC0, TIOCD0, TIOCA1, TIOCB1, TIOCA2, and TIOCB2), DMAC output pins ( $\overline{\text{DACK0}}$  and  $\overline{\text{DACK1}}$ ), 14-bit PWM output pins (PWM2 and PWM3) external interrupt pins ( $\overline{\text{IRQ0}}$  and  $\overline{\text{IRQ1}}$ ), and address bus output pins (A23 to A20). Port 1 pin functions change according to the operating mode.

Figure 10A-1 shows the port 1 pin configuration.



**Figure 10A-1 Port 1 Pin Functions**

### 10A.2.2 Register Configuration

Table 10A-2 shows the port 1 register configuration.

**Table 10A-2 Port 1 Registers**

Name	Abbreviation	R/W	Initial Value	Address*
Port 1 data direction register	P1DDR	W	H'00	H'FE30
Port 1 data register	P1DR	R/W	H'00	H'FF00
Port 1 register	PORT1	R	Undefined	H'FFB0

Note: \* Lower 16 bits of the address.

#### Port 1 Data Direction Register (P1DDR)

Bit	:	7	6	5	4	3	2	1	0
		P17DDR	P16DDR	P15DDR	P14DDR	P13DDR	P12DDR	P11DDR	P10DDR
Initial value :		0	0	0	0	0	0	0	0
R/W	:	W	W	W	W	W	W	W	W

P1DDR is an 8-bit write-only register, the individual bits of which specify input or output for the pins of port 1. P1DDR cannot be read; if it is, an undefined value will be read.

Setting a P1DDR bit to 1 makes the corresponding port 1 pin an output pin, while clearing the bit to 0 makes the pin an input pin.

P1DDR is initialized to H'00 by a power-on reset, and in hardware standby mode. It retains its prior state by a manual reset or in software standby mode. Because PPG, TPU, and DMAC are initialized at a manual reset, pin states are determined by P1DDR and P1DR.

#### Port 1 Data Register (P1DR)

Bit	:	7	6	5	4	3	2	1	0
		P17DR	P16DR	P15DR	P14DR	P13DR	P12DR	P11DR	P10DR
Initial value :		0	0	0	0	0	0	0	0
R/W	:	R/W	R/W	R/W	R/W	R/W	R/W	R/W	R/W

P1DR is an 8-bit readable/writable register that stores output data for the port 1 pins (P17 to P10).

P1DR is initialized to H'00 by a power-on reset, and in hardware standby mode. It retains its prior state by a manual reset or in software standby mode.

### Port 1 Register (PORT1)

Bit	:	7	6	5	4	3	2	1	0
		P17	P16	P15	P14	P13	P12	P11	P10
Initial value :		—*	—*	—*	—*	—*	—*	—*	—*
R/W	:	R	R	R	R	R	R	R	R

Note: \* Determined by state of pins P17 to P10.

PORT1 is an 8-bit read-only register that shows the pin states. It cannot be written to. Writing of output data for the port 1 pins (P17 to P10) must always be performed on P1DR.

If a port 1 read is performed while P1DDR bits are set to 1, the P1DR values are read. If a port 1 read is performed while P1DDR bits are cleared to 0, the pin states are read.

After a power-on reset and in hardware standby mode, PORT1 contents are determined by the pin states, as P1DDR and P1DR are initialized. PORT1 retains its prior state by a manual reset or in software standby mode.

### 10A.2.3 Pin Functions

Port 1 pins also function as PPG output pins (PO15 to PO8), TPU I/O pins (TCLKA, TCLKB, TCLKC, TCLKD, TIOCA0, TIOCB0, TIOCC0, TIOCD0, TIOCA1, TIOCB1, TIOCA2, and TIOCB2), DMAC output pins ( $\overline{DACK0}$  and  $\overline{DACK1}$ ), external interrupt input pins ( $\overline{IRQ0}$  and  $\overline{IRQ1}$ ), 14-bit PWM output pins (PWM2 and PWM3), and address bus output pins (A23 to A20). Port 1 pin functions are shown in table 10A-3.

**Table 10A-3 Port 1 Pin Functions**

Pin	Selection Method and Pin Functions					
P17/PO15/ TIOCB2/PWM3/ TCLKD	The pin function is switched as shown below according to the combination of the TPU channel 2 setting (by bits MD3 to MD0 in TMDR2, bits IOB3 to IOB0 in TIOR2, and bits CCLR1 and CCLR0 in TCR2), bits TPSC2 to TPSC0 in TCR0 and TCR5, OEB bit in DACR3, bit NDER15 in NDERH, and bit P17DDR.					
	TPU Channel 2 Setting	Table Below (1)	Table Below (2)			
	OEB	—	0	0	0	1
	P17DDR	—	0	1	1	—
	NDER15	—	—	0	1	—
	Pin function	TIOCB2 output	P17 input	P17 output	PO15 output	PWM3 output
TIOCB2 input*1						
TCLKD input*2						

Notes: \*1 TIOCB2 input when MD3 to MD0 = B'0000 or B'01xx, and IOB3 = 1.

\*2 TCLKD input when the setting for either TCR0 or TCR5 is: TPSC2 to TPSC0 = B'111.

TCLKD input when channels 2 and 4 are set to phase counting mode.

TPU Channel 2 Setting	(2)	(1)	(2)	(2)	(1)	(2)
MD3 to MD0	B'0000, B'01xx		B'0010	B'0011		
IOB3 to IOB0	B'0000 B'0100 B'1xxx	B'0001 to B'0011 B'0101 to B'0111	—	B'xx00	Other than B'xx00	
CCLR1, CCLR0	—	—	—	—	Other than B'10	B'10
Output function	—	Output compare output	—	—	PWM mode 2 output	—

x: Don't care

**Pin****Selection Method and Pin Functions**

P16/PO14/  
TIOCA2/PWM2/  
 $\overline{\text{IRQ1}}$

The pin function is switched as shown below according to the combination of the TPU channel 2 setting (by bits MD3 to MD0 in TMDR2, bits IOA3 to IOA0 in TIOR2, and bits CCLR1 and CCLR0 in TCR2), OEA bit in DACR3, bit NDER14 in NDERH, and bit P16DDR.

TPU Channel 2 Setting	Table Below (1)	Table Below (2)			
OEA	—	0	0	0	1
P16DDR	—	0	1	1	—
NDER14	—	—	0	1	—
Pin function	TIOCA2 output	P16 input	P16 output	PO14 output	PWM2 output
		TIOCA2 input*1			
	$\overline{\text{IRQ1}}$ input				

TPU Channel 2 Setting	(2)	(1)	(2)	(1)	(1)	(2)
MD3 to MD0	B'0000, B'01xx		B'001x	B'0010	B'0011	
IOA3 to IOA0	B'0000 B'0100 B'1xxx	B'0001 to B'0011 B'0101 to B'0111	B'xx00	Other than B'xx00		
CCLR1, CCLR0	—	—	—	—	Other than B'01	B'01
Output function	—	Output compare output	—	PWM mode 1 output*2	PWM mode 2 output	—

x: Don't care

Notes: \*1 TIOCA2 input when MD3 to MD0 = B'0000 or B'01xx, and IOA3 = 1.

\*2 TIOCB2 output is disabled.



**Pin Selection Method and Pin Functions**

P15/PO13/  
TIOCB1/TCLKC

The pin function is switched as shown below according to the combination of the TPU channel 1 setting (by bits MD3 to MD0 in TMDR1, bits IOB3 to IOB0 in TIOR1, and bits CCLR1 and CCLR0 in TCR1), bits TPSC2 to TPSC0 in TCR0, TCR2, TCR4, and TCR5, bit NDER13 in NDERH, and bit P15DDR.

TPU Channel 1 Setting	Table Below (1)	Table Below (2)		
P15DDR	—	0	1	1
NDER13	—	—	0	1
Pin function	TIOCB1 output	P15 input	P15 output	PO13 output
		TIOCB1 input*1		
TCLKC input*2				

Notes: \*1 TIOCB1 input when MD3 to MD0 = B'0000 or B'01xx, and IOB3 to IOB0 = B'10xx.

\*2 TCLKC input when the setting for either TCR0 or TCR2 is: TPSC2 to TPSC0 = B'110; or when the setting for either TCR4 or TCR5 is TPSC2 to TPSC0 = B'101.

TCLKC input when channels 2 and 4 are set to phase counting mode.

TPU Channel 1 Setting	(2)	(1)	(2)	(2)	(1)	(2)
MD3 to MD0	B'0000, B'01xx		B'0010	B'0011		
IOB3 to IOB0	B'0000 B'0100 B'1xxx	B'0001 to B'0011 B'0101 to B'0111	—	B'xx00	Other than B'xx00	
CCLR1, CCLR0	—	—	—	—	Other than B'10	B'10
Output function	—	Output compare output	—	—	PWM mode 2 output	—

x: Don't care

**Pin**

**Selection Method and Pin Functions**

P14/PO12/  
TIOCA1/IRQ0

The pin function is switched as shown below according to the combination of the TPU channel 1 setting (by bits MD3 to MD0 in TMDR1, bits IOA3 to IOA0 in TIOR1, and bits CCLR1 and CCLR0 in TCR1), bit NDER12 in NDERH, and bit P14DDR.

TPU Channel 1 Setting	Table Below (1)	Table Below (2)		
P14DDR	—	0	1	1
NDER12	—	—	0	1
Pin function	TIOCA1 output	P14 input	P14 output	PO12 output
		TIOCA1 input*1		
IRQ0 input				

TPU Channel 1 Setting	(2)	(1)	(2)	(1)	(1)	(2)
MD3 to MD0	B'0000, B'01xx		B'001x	B'0010	B'0011	
IOA3 to IOA0	B'0000 B'0100 B'1xxx	B'0001 to B'0011 B'0101 to B'0111	B'xx00	Other than B'xx00	Other than B'xx00	
CCLR1, CCLR0	—	—	—	—	Other than B'01	B'01
Output function	—	Output compare output	—	PWM mode 1 output*2	PWM mode 2 output	—

x: Don't care

Notes: \*1 TIOCA1 input when MD3 to MD0 = B'0000 or B'01xx, and IOA3 to IOA0 = B'10xx.

\*2 TIOCB1 output is disabled.

**Pin Selection Method and Pin Functions**

P13/PO11/  
TIOCD0/TCLKB/  
A23

The pin function is switched as shown below according to the combination of the operating mode, and the TPU channel 0 setting (by bits MD3 to MD0 in TMDR0, bits IOD3 to IOD0 in TIOR0L, and bits CCLR2 to CCLR0 in TCR0), bits TPSC2 to TPSC0 in TCR0 to TCR2, bits AE3 to AE0 in PFCR, bit NDER11 in NDERH, and bit P13DDR.

Operating mode	Modes 4 to 6				
AE3 to AE0	B'0000 to B'1110				B'1111
TPU Channel 0 Setting	Table Below (1)	Table Below (2)			—
P13DDR	—	0	1	1	—
NDER11	—	—	0	1	—
Pin function	TIOCD0 output	P13 input	P13 output	PO11 output	A23 output
		TIOCD0 input*1			
	TCLKB input*2				

Operating mode	Mode 7				
AE3 to AE0	—				
TPU Channel 0 Setting	Table Below (1)	Table Below (2)			—
P13DDR	—	0	1	1	—
NDER11	—	—	0	1	—
Pin function	TIOCD0 output	P13 input	P13 output	PO11 output	A23 output
		TIOCD0 input*1			
	TCLKB input*2				

Notes: \*1 TIOCD0 input when MD3 to MD0 = B'0000, and IOD3 to IOD0 = B'10xx.

\*2 TCLKB input when the setting for TCR0 to TCR2 is: TPSC2 to TPSC0 = B'101.  
TCLKB input when channels 1 and 5 are set to phase counting mode.

**Pin Selection Method and Pin Functions**

P13/PO11/ TIOC0/TCLKB/ A23 (cont)	TPU Channel 0 Setting	(2)	(1)	(2)	(2)	(1)	(2)
	MD3 to MD0	B'0000		B'0010	B'0011		
	IOD3 to IOD0	B'0000 B'0100 B'1xxx	B'0001 to B'0011 B'0101 to B'0111	—	B'xx00	Other than B'xx00	
	CCLR2 to CCLR0	—	—	—	—	Other than B'110	B'110
	Output function	—	Output compare output	—	—	PWM mode 2 output	—

x: Don't care

**Pin****Selection Method and Pin Functions**

P12/PO10/  
TIOCC0/TCLKA/  
A22

The pin function is switched as shown below according to the combination of the operating mode, and the TPU channel 0 setting (by bits MD3 to MD0 in TMDR0, bits IOC3 to IOC0 in TIOR0L, and bits CCLR2 to CCLR0 in TCR0), bits TPSC2 to TPSC0 in TCR0 to TCR5, bits AE3 to AE0 in PFCR, bit NDER10 in NDERH, and bit P12DDR.

Operating mode	Modes 4 to 6				
AE3 to AE0	B'0000 to B'1110				B'1111
TPU Channel 0 Setting	Table Below (1)	Table Below (2)			—
P12DDR	—	0	1	1	—
NDER10	—	—	0	1	—
Pin function	TIOCC0 output	P12 input	P12 output	PO10 output	A22 output
		TIOCC0 input* <sup>1</sup>			
	TCLKA input* <sup>2</sup>				

Operating mode	Mode 7				
AE3 to AE0	—				
TPU Channel 0 Setting	Table Below (1)	Table Below (2)			—
P12DDR	—	0	1	1	—
NDER10	—	—	0	1	—
Pin function	TIOCC0 output	P12 input	P12 output	PO10 output	A22 output
		TIOCC0 input* <sup>1</sup>			
	TCLKA input* <sup>2</sup>				

**Pin Selection Method and Pin Functions**

P12/PO10/ TIOCC0/TCLKA/ A22 (cont)	TPU Channel 0 Setting	(2)	(1)	(2)	(1)	(1)	(2)
	MD3 to MD0	B'0000		B'001x	B'0010	B'0011	
	IOC3 to IOC0	B'0000 B'0100 B'1xxx	B'0001 to B'0011 B'0101 to B'0111	B'xx00	Other than B'xx00		
	CCLR2 to CCLR0	—	—	—	—	Other than B'101	B'101
	Output function	—	Output compare output	—	PWM mode 1 output* <sup>3</sup>	PWM mode 2 output	—

x: Don't care

Notes: \*1 TIOCC0 input when MD3 to MD0 = B'0000, and IOC3 to IOC0 = B'10xx.

\*2 TCLKA input when the setting for TCR0 to TCR5 is: TPSC2 to TPSC0 = B'100.

TCLKA input when channels 1 and 5 are set to phase counting mode.

\*3 TIOCD0 output is disabled.

When BFA = 1 or BFB = 1 in TMDR0, output is disabled and setting (2) applies.

**Pin Selection Method and Pin Functions**

P11/PO9/TIOCB0/  
DACK1/A21 The pin function is switched as shown below according to the combination of the operating mode, and the TPU channel 0 setting (by bits MD3 to MD0 in TMDR0, and bits IOB3 to IOB0 in TIOR0H), bits AE3 to AE0 in PFCR, bit NDER9 in NDERH, SAE1 bit in DMABCRH, and bit P11DDR.

Operating mode	Modes 4 to 6					
AE3 to AE0	B'0000 to B'1101					B'1110 to B'1111
SAE1	0			1		—
TPU Channel 0 Setting	Table Below (1)	Table Below (2)			—	—
P11DDR	—	0	1	1	—	—
NDER9	—	—	0	1	—	—
Pin function	TIOCB0 output	P11 input	P11 output	PO9 output	DACK1 output	A21 output
		TIOCB0 input*				

Operating mode	Mode 7					
AE3 to AE0	—					
SAE1	0				1	
TPU Channel 0 Setting	Table Below (1)	Table Below (2)			—	
P11DDR	—	0	1	1	—	
NDER9	—	—	0	1	—	
Pin function	TIOCB0 output	P11 input	P11 output	PO9 output	DACK1 output	
		TIOCB0 input*				

Note: \* TIOCB0 input when MD3 to MD0 = B'0000, and IOB3 to IOB0 = B'10xx.

**Pin Selection Method and Pin Functions**

P11/PO9/TIOCB0/ DACK1/A21 (cont)	TPU Channel 0 Setting	(2)	(1)	(2)	(2)	(1)	(2)
	MD3 to MD0	B'0000		B'0010	B'0011		
	IOB3 to IOB0	B'0000 B'0100 B'1xxx	B'0001 to B'0011 B'0101 to B'0111	—	B'xx00	Other than B'xx00	
	CCLR2 to CCLR0	—	—	—	—	Other than B'010	B'010
	Output function	—	Output compare output	—	—	PWM mode 2 output	—

x: Don't care



**Pin Selection Method and Pin Functions**

P10/PO8/TIOCA0/  
DACK0/A20

The pin function is switched as shown below according to the combination of the operating mode, and the TPU channel 0 setting (by bits MD3 to MD0 in TMDR0, bits IOA3 to IOA0 in TIOR0H, and bits CCLR2 to CCLR0 in TCR0), bits AE3 to AE0 in PFCR, bit NDER8 in NDERH, SAE0 bit in DMABCRH, and bit P10DDR.

Operating mode	Modes 4 to 6					
AE3 to AE0	B'0000 to B'1110					B'1101 to B'1111
SAE0	0			1		—
TPU Channel 0 Setting	Table Below (1)	Table Below (2)			—	—
P10DDR	—	0	1	1	—	—
NDER8	—	—	0	1	—	—
Pin function	TIOCA0 output	P10 input	P10 output	PO8 output	DACK0 output	A20 output
		TIOCA0 input* <sup>1</sup>				

Operating mode	Mode 7					
AE3 to AE0	—					
SAE0	0				1	
TPU Channel 0 Setting	Table Below (1)	Table Below (2)			—	
P10DDR	—	0	1	1	—	
NDER8	—	—	0	1	—	
Pin function	TIOCA0 output	P10 input	P10 output	PO8 output	DACK0 output	
		TIOCA0 input* <sup>1</sup>				

**Pin Selection Method and Pin Functions**

P10/PO8/TIOCA0/ DACK0/A20 (cont)	TPU Channel 0 Setting	(2)	(1)	(2)	(1)	(1)	(2)
		MD3 to MD0	B'0000		B'001x	B'0010	B'0011
	IOA3 to IOA0	B'0000 B'0100 B'1xxx	B'0001 to B'0011 B'0101 to B'0111	B'xx00	Other than B'xx00		
	CCLR2 to CCLR0	—	—	—	—	Other than B'001	B'001
	Output function	—	Output compare output	—	PWM mode 1 output*2	PWM mode 2 output	—

x: Don't care

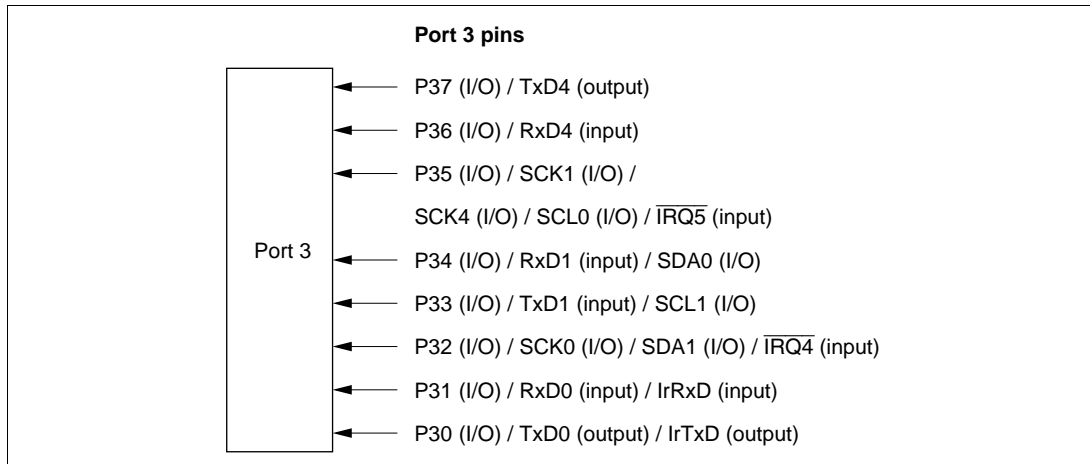
Notes: \*1 TIOCA0 input when MD3 to MD0 = B'0000, and IOA3 to IOA0 = B'10xx.

\*2 TIOCB0 output is disabled.

## 10A.3 Port 3

### 10A.3.1 Overview

Port 3 is an 8-bit I/O port. Port 3 is a multi-purpose port for SCI I/O pins (TxD0, RxD0, SCK0, IrTxD, IrRxD, TxD1, RxD1, SCK1, TxD4, RxD4, and SCK4), external interrupt input pins ( $\overline{\text{IRQ4}}$  and  $\overline{\text{IRQ5}}$ ) and IIC I/O pins (SCL0, SDA0, SCL1, and SDA1). All of the port 3 pin functions have the same operating mode. The configuration for each of the port 3 pins is shown in figure 10A-2.



**Figure 10A-2 Port 3 Pin Functions**

### 10A.3.2 Register Configuration

Table 10A-4 shows the configuration of port 3 registers.

**Table 10A-4 Port 3 Register Configuration**

Name	Abbreviation	R/W	Initial Value	Address*
Port 3 data direction register	P3DDR	W	H'00	H'FE32
Port 3 data register	P3DR	R/W	H'00	H'FF02
Port 3 register	PORT3	R	Undefined	H'FFB2
Port 3 open drain control register	P3ODR	R/W	H'00	H'FE46

Note: \* Lower 16 bits of the address.

### Port 3 Data Direction Register (P3DDR)

Bit	:	7	6	5	4	3	2	1	0
		P37DDR	P36DDR	P35DDR	P34DDR	P33DDR	P32DDR	P31DDR	P30DDR
Initial value	:	0	0	0	0	0	0	0	0
R/W	:	W	W	W	W	W	W	W	W

P3DDR is an 8-bit write-dedicated register, which specifies the I/O for each port 3 pin by bit. Read is disabled. If a read is carried out, undefined values are read out.

By setting P3DDR to 1, the corresponding port 3 pins become output, and by clearing to 0 they become input.

P3DDR is initialized to H'00 by a power-on reset and in hardware standby mode. The previous state is maintained by a manual reset and in software standby mode. SCI and IIC are initialized, so the pin state is determined by the specification of P3DDR and P3DR.

### Port 3 Data Register (P3DR)

Bit	:	7	6	5	4	3	2	1	0
		P37DR	P36DR	P35DR	P34DR	P33DR	P32DR	P31DR	P30DR
Initial value	:	0	0	0	0	0	0	0	0
R/W	:	R/W	R/W	R/W	R/W	R/W	R/W	R/W	R/W

P3DR is an 8-bit readable/writable register, which stores the output data of port 3 pins (P35 to P30).

P3DR is initialized to H'00 by a power-on reset and in hardware standby mode. The previous state is maintained by a manual reset and in software standby mode.

### Port 3 Register (PORT3)

Bit	:	7	6	5	4	3	2	1	0
		P37	P36	P35	P34	P33	P32	P31	P30
Initial value	:	—*	—*	—*	—*	—*	—*	—*	—*
R/W	:	R	R	R	R	R	R	R	R

Note: \* Determined by the state of pins P37 to P30.

PORT3 is an 8-bit read-dedicated register, which reflects the state of pins. Write is disabled. Always carry out writing off output data of port 3 pins (P37 to P30) to P3DR without fail.

When P3DDR is set to 1, if port 3 is read, the values of P3DR are read. When P3DDR is cleared to 0, if port 3 is read, the states of pins are read out.

P3DDR and P3DR are initialized by a power-on reset and in hardware standby mode, so PORT3 is determined by the state of the pins. The previous state is maintained by a manual reset and in software standby mode.

### Port 3 Open Drain Control Register (P3ODR)

Bit	:	7	6	5	4	3	2	1	0
		P37ODR	P36ODR	P35ODR	P34ODR	P33ODR	P32ODR	P31ODR	P30ODR
Initial value	:	0	0	0	0	0	0	0	0
R/W	:	R/W	R/W	R/W	R/W	R/W	R/W	R/W	R/W

P3ODR is an 8-bit readable/writable register, which controls the on/off of port 3 pins (P37 to P30).

By setting P3ODR to 1, the port 3 pins become an open drain out, and when cleared to 0 they become CMOS output.

P3ODR is initialized to H'00 by a power-on reset and in hardware standby mode. The previous state is maintained by a manual reset and in software standby mode.

### 10A.3.3 Pin Functions

The port 3 pins double as SCI I/O input pins (TxD0, RxD0, SCK0, TxD1, RxD1, and SCK1). The functions of port 3 pins are shown in table 10A-5.

**Table 10A-5 Port 3 Pin Functions**

Pin	Selection Method and Pin Functions					
P37/TxD4	Switches as follows according to combinations of SCR TE bit of SCI4 and the P37DDR bit.					
	TE	0			1	
	P37DDR	0	1		—	
	Pin function	P37 input pin	P37 output pin*		TxD4 output pin	
Note: * When P37ODR = 1, it becomes NMOS open drain output.						
P36/RxD4	Switches as follows according to combinations of SCR RE bit of SCI4 and the P36DDR bit.					
	RE	0			1	
	P36DDR	0	1		—	
	Pin function	P36 input pin	P36 output pin*		RxD4 input pin	
Note: * When P36ODR = 1, it becomes NMOS open drain output.						
P35/SCK1/ SCK4/SCL0/ IRQ5	Switches as follows according to combinations of ICCR0 ICE bit of IIC0, SMR C/ $\bar{A}$ bit of SCI1 or SCI4, SCR CKE0 and CKE1 bits, and the P35DDR bit.					
	When used as a SCL0 I/O pin, always be sure to clear the following bits to 0: SMR C/ $\bar{A}$ bits of SCI1 or SCI4, and SCR CKE0 and CKE1 bits. Do not set SCK1 and SCK4 to simultaneous output.					
	The SCL0 output format is NMOS open drain output, enabling direct bus driving.					
	ICE	0				1
CKE1 (SCI1)	0			0, 1, 1	0	
CKE1 (SCI4)	0			1, 0, 1	0	
C/ $\bar{A}$ (SCI1)	0		1	—	0	
C/ $\bar{A}$ (SCI4)	0		1	—	0	
CKE0 (SCI1)	0	0, 1, 1* <sup>2</sup>		—	0	
CKE0 (SCI4)	0	1, 0, 1* <sup>2</sup>		—	0	
P35DD	0	1	—	—	—	
Pin function	P35 input pin	P35 output pin* <sup>1</sup>	SCK1/SCK4 output pin* <sup>1</sup>	SCK1/SCK4 output pin* <sup>1</sup>	SCK1/SCK4 input pin	SCL0 I/O pin
	IRQ5 input					
Notes: * <sup>1</sup> Output type is NMOS push-pull. When P35ODR = 1, it becomes NMOS open drain output.						
* <sup>2</sup> SCK1 and SCK4 must not be output simultaneously.						

**Pin Selection Method and Pin Functions**

**P34/RxD1/SDA0** Switches as follows according to combinations of ICCR0 ICE bit of IIC0, SCR RE bit of SCI1, and the P34DDR bit.

The SDA0 output format becomes NMOS open drain output, enabling direct bus driving.

ICE	0			1
RE	0		1	—
P34DDR	0	1	—	—
Pin function	P34 input pin	P34 output pin*	RxD1 input pin	SDA0 I/O pin

Note: \* Output type is NMOS push-pull. When P34ODR = 1, it becomes NMOS open drain tray.

**P33/TxD1/SCL1** Switches as follows according to combinations of ICCR1 ICE bit of IIC1, SCR TE bit of SCI1 and the P33DDR bit.

The SCL1 output format becomes NMOS open drain output, enabling direct bus driving.

ICE	0			1
TE	0		1	—
P33DDR	0	1	—	—
Pin function	P33 input pin	P33 output pin*	TxD1 output pin*	SCL1 I/O pin*

Note: \* When P33ODR = 1, it becomes NMOS open drain output.

**P32/SCK0/SDA1/IRQ4** Switches as follows according to combinations of ICCR1 ICE bit of IIC1, SMR C/ $\bar{A}$  bit of SCI0, SCR CKE0 and CKE1 bits, and the P32DDR bit.

If using as an SDA1 input pin, always set SMR C/ $\bar{A}$  bit of SCI0 and SCR CKE0 and CKE1 bits to 0 without fail.

The SDA1 output format becomes NMOS open drain output, enabling direct bus driving.

ICE	0				1	
CKE1	0			1	0	
C/ $\bar{A}$	0		1	—	0	
CKE0	0	1	—	—	0	
P32DDR	0	1	—	—	—	
Pin function	P32 input pin	P32 output pin	SCK0 output pin*	SCK0 output pin*	SCK0 input pin	SDA1 I/O pin
	$\overline{\text{IRQ4}}$ input					

Note: \* When P32ODR = 1, it becomes NMOS open drain output.

**Pin Selection Method and Pin Functions**

P31/RxD0/IrRxD Switches as follows according to combinations of SCR RE bit of SCI0 and the P31DDR bit.

RE	0		1
P31DDR	0	1	—
Pin function	P31 input pin	P31 output pin*	RxD0/IrRxD input pin

Note: \* When P31ODR = 1, it becomes NMOS open drain output.

P30/TxD0/IrTxD Switches as follows according to combinations of SCR TE bit of SCI0 and the P30DDR bit.

TE	0		1
P30DDR	0	1	—
Pin function	P30 input pin	P30 output pin*	TxD0/IrTxD output pin*

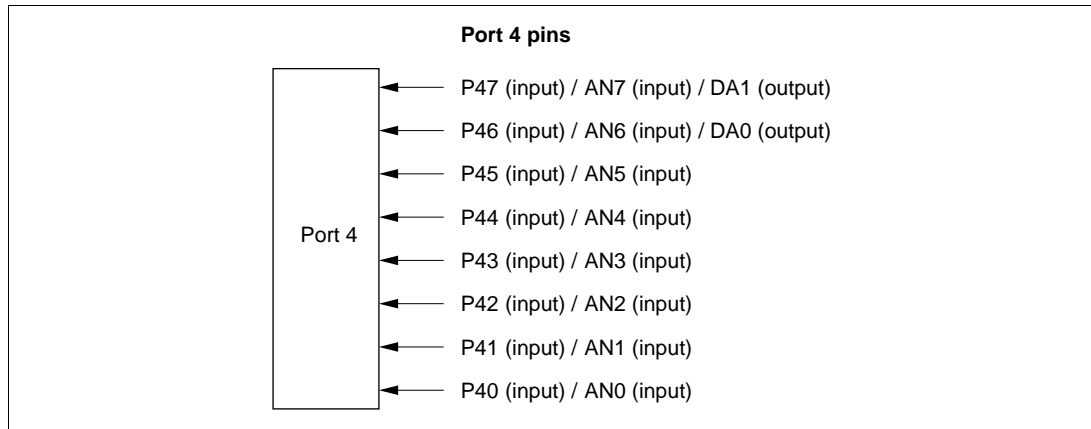
Note: \* When P30ODR = 1, it becomes NMOS open drain output.



## 10A.4 Port 4

### 10A.4.1 Overview

Port 4 is an 8-bit input-only port. Port 4 pins also function as A/D converter analog input pins (AN0 to AN7) and D/A converter analog output pins (DA0 and DA1). Port 4 pin functions are the same in all operating modes. Figure 10A-3 shows the port 4 pin configuration.



**Figure 10A-3 Port 4 Pin Functions**

### 10A.4.2 Register Configuration

Table 10A-6 shows the port 4 register configuration. Port 4 is an input-only port, and does not have a data direction register or data register.

**Table 10A-6 Port 4 Registers**

Name	Abbreviation	R/W	Initial Value	Address*
Port 4 register	PORT4	R	Undefined	H'FFB3

Note: \* Lower 16 bits of the address.

**Port 4 Register (PORT4):** The pin states are always read when a port 4 read is performed.

Bit	:	7	6	5	4	3	2	1	0
		P47	P46	P45	P44	P43	P42	P41	P40
Initial value :		—*	—*	—*	—*	—*	—*	—*	—*
R/W	:	R	R	R	R	R	R	R	R

Note: \* Determined by state of pins P47 to P40.

### 10A.4.3 Pin Functions

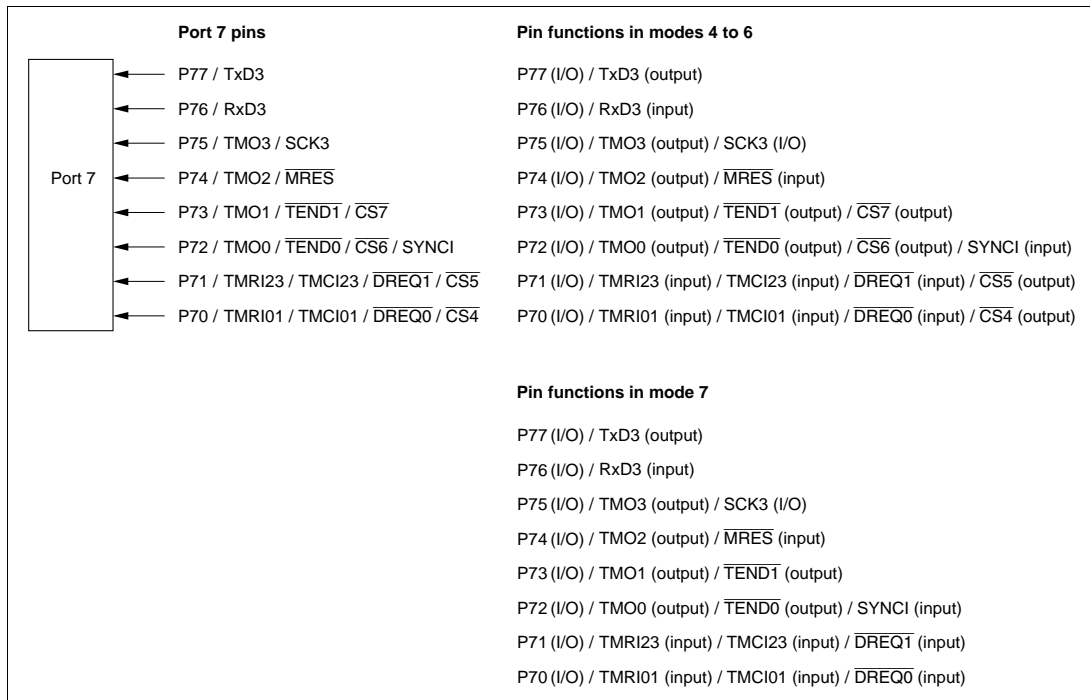
Port 4 pins also function as A/D converter analog input pins (AN0 to AN7) and D/A converter analog output pins (DA0 and DA1).

## 10A.5 Port 7

### 10A.5.1 Overview

Port 7 is an 8-bit I/O port. Port 7 is a multipurpose port for the 8-bit timer I/O pins (TMRI01, TMCI01, TMRI23, TMCI23, TMO0, TMO1, TMO2, and TMO3), DMAC I/O pins ( $\overline{\text{DREQ0}}$ ,  $\overline{\text{TEND0}}$ ,  $\overline{\text{DREQ1}}$ , and  $\overline{\text{TEND1}}$ ), bus control output pins ( $\overline{\text{CS4}}$  to  $\overline{\text{CS7}}$ ), IIC input pin (SYNCI), SCI I/O pins (SCK3, RxD3, and TxD3) and manual reset input pin ( $\overline{\text{MRES}}$ ). The pin functions for P77 to P74 are the same in all operating modes. P73 to P70 pin functions are switched according to operating mode.

Figure 10A-4 shows the configuration for port 7 pins.



**Figure 10A-4 Port 7 Pin Functions**

### 10A.5.2 Register Configuration

Table 10A-7 shows the port 7 register configuration.

**Table 10A-7 Port 7 Register Configuration**

Name	Abbreviation	R/W	Initial Value	Address*
Port 7 data direction register	P7DDR	W	H'00	H'FE36
Port 7 data register	P7DR	R/W	H'00	H'FF06
Port 7 register	PORT7	R	Undefined	H'FFB6

Note: \* Lower 16 bits of the address.

#### Port 7 Data Direction Register (P7DDR)

Bit	:	7	6	5	4	3	2	1	0
		P77DDR	P76DDR	P75DDR	P74DDR	P73DDR	P72DDR	P71DDR	P70DDR
Initial value	:	0	0	0	0	0	0	0	0
R/W	:	W	W	W	W	W	W	W	W

P7DDR is an 8-bit write-dedicated register, which specifies the I/O for each port 7 pin by bit. Read is disabled. If a read is carried out, undefined values are read out.

By setting P7DDR to 1, the corresponding port 7 pins become output, and by clearing to 0 they become input.

P7DDR is initialized to H'00 by a power-on reset and in hardware standby mode. The previous state is maintained by a manual reset and in software standby mode. DMAC, 8-bit timer and SCI are initialized by a manual reset, so the pin state is determined by the specification of P7DDR and P7DR.

### Port 7 Data Register (P7DR)

Bit	:	7	6	5	4	3	2	1	0
		P77DR	P76DR	P75DR	P74DR	P73DR	P72DR	P71DR	P70DR
Initial value	:	0	0	0	0	0	0	0	0
R/W	:	R/W	R/W	R/W	R/W	R/W	R/W	R/W	R/W

P7DR is an 8-bit readable/writable register, which stores the output data of port 7 pins (P77 to P70).

P7DR is initialized to H'00 by a power-on reset and in hardware standby mode. The previous state is maintained by a manual reset and in software standby mode.

### Port 7 Register (PORT7)

Bit	:	7	6	5	4	3	2	1	0
		P77	P76	P75	P74	P73	P72	P71	P70
Initial value	:	—*	—*	—*	—*	—*	—*	—*	—*
R/W	:	R	R	R	R	R	R	R	R

Note: \* Determined by the state of pins P77 to P70.

PORT7 is an 8-bit read-dedicated register, which reflects the state of pins. Write is disabled. Always carry out writing off output data of port 7 pins (P77 to P70) to P7DR without fail.

When P7DDR is set to 1, if port 7 is read, the values of P7DR are read. When P7DDR is cleared to 0, if port 7 is read, the states of pins are read out.

P7DDR and P7DR are initialized by a power-on reset and in hardware standby mode, so PORT7 is determined by the state of the pins. The previous state is maintained by a manual reset and in software standby mode.

### 10A.5.3 Pin Functions

The pins of port 7 are multipurpose pins which function as 8-bit timer I/O pins, (TMRI01, TMCIO1, TMRI23, TMCIO23, TMO0, TMO1, TMO2, and TMO3), DMAC I/O pins (DREQ0, TEND0, DREQ1, and TEND1), bus control output pins (CS4 to CS7), IIC input pin (SYNCl), SCI I/O pins (SCK3, RxD3, and TxD3) and manual reset input pin (MRES). Table 10A-8 shows the functions of port 7 pins.

**Table 10A-8 Port 7 Pin Functions**

Pin	Selection Method and Pin Functions						
P77/TxD3	Switches as follows according to combinations of SCR TE bit of SCI3, and the P77DDR bit.						
	TE	0			1		
	P77DDR	0		1		—	
	Pin function	P77 input pin		P77 output pin		TxD3 output pin	
P76/RxD3	Switches as follows according to combinations of SCR RE bit of SCI3 and the P76DDR bit.						
	RE	0			1		
	P76DDR	0		1		—	
	Pin function	P76 input pin		P76 output pin		RxD3 I/O pin	
P75/TMO3/ SCK3	Switches as follows according to combinations of SMR C/A bit of SCI3, SCR CKE0 and CKE1 bits, TCSR3 OS3 to OS0 bits of the 8-bit timer, and the P75DDR bit.						
	OS3 to OS0	All 0				Any is 1	
	CKE1	0			1		—
	C/A	0		1		—	
	CKE0	0		1		—	
	P75DDR	0	1	—		—	
	Pin function	P75 input pin	P75 output pin	SCK3 output pin	SCK3 output pin	SCK3 input pin	TMO3 output

**Pin Selection Method and Pin Functions**

**P74/TMO2/MRES** Switches as follows according to combinations of TCSR2 OS3 to OS0 bits of the 8-bit timer, SYSCR MRESE bit and the P74DDR bit.

MRESE	0			1
OS3 to OS0	All 0		Any is 1	—
P74DDR	0	1	—	—
Pin function	P74 input pin	P74 output pin	TMO2 output	$\overline{\text{MRES}}$ input pin

**P73/TMO1/TEND1/CS7** Switches as follows according to combinations of operating mode and DMATCR TEE1 bit of DMAC, TCSR1 OS3 to OS0 bits of the 8-bit timer, and the P73DDR bit.

Operating Mode	Modes 4 to 6				Mode 7			
TEE1	0		1	—	0		1	—
OS3 to OS0	All 0		Any is 1	—	All 0		Any is 1	—
P73DDR	0	1	—	—	0	1	—	—
Pin function	P73 input pin	$\overline{\text{CS7}}$ output pin	TMO1 output	$\overline{\text{TEND1}}$ output	P73 input pin	P73 output pin	TMO1 output	$\overline{\text{TEND1}}$ output

**P72/TMO0/TEND0/CS6/SYNCl** Switches as follows according to combinations of operating mode and DMATCR TEE0 bit of DMAC, OS3 to OS0 bits of 8-bit timer TCSR0, and the P72DDR bit.

Operating Mode	Modes 4 to 6				Mode 7			
TEE0	0		1	—	0		1	—
OS3 to OS0	All 0		Any is 1	—	All 0		Any is 1	—
P72DDR	0	1	—	—	0	1	—	—
Pin function	P72 input pin	$\overline{\text{CS6}}$ output pin	TMO0 output	$\overline{\text{TEND1}}$ output	P72 input pin	P72 output pin	TMO0 output	$\overline{\text{TEND1}}$ output
	SYNCl input	—	SYNCl input					

**Pin Selection Method and Pin Functions**

P71/TMRI23/  
TMC123/  
DREQ1/CS5 Switches as follows according to operating mode and P71DDR.

Operating Mode	Modes 4 to 6		Mode 7	
	P71DDR	0	1	0
Pin function	P71 input Pin	$\overline{CS5}$ output	P71 input pin	P71 output pin
	$\overline{DREQ0}$ , TMRI23, TMC123 input	—	$\overline{DREQ0}$ , TMRI23, TMC123 input	

P70/TMRI01/  
TMC101/  
DREQ0/CS4 Switches as follows according to operating mode and P70DDR.

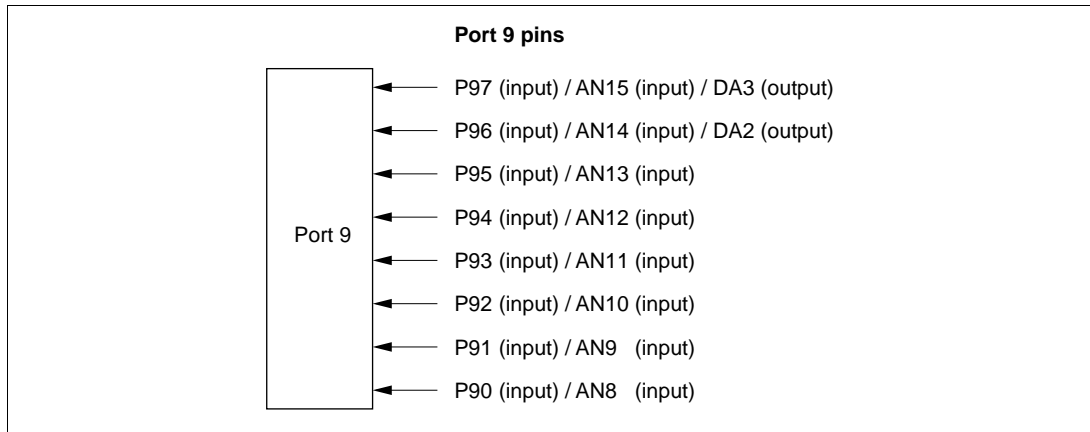
Operating Mode	Modes 4 to 6		Mode 7	
	P70DDR	0	1	0
Pin function	P70 input pin	$\overline{CS4}$ output	P70 input pin	P70 output pin
	$\overline{DREQ0}$ , TMRI01, TMC101 input	—	$\overline{DREQ0}$ , TMRI01, TMC101 input	



## 10A.6 Port 9

### 10A.6.1 Overview

Port 9 is an 8-bit input-only port. Port 9 pins also function as A/D converter analog input pins (AN8 to AN15) and D/A converter analog output pins (DA2 and DA3). Port 9 pin functions are the same in all operating modes. Figure 10A-5 shows the port 9 pin configuration.



**Figure 10A-5 Port 9 Pin Functions**

### 10A.6.2 Register Configuration

Table 10A-9 shows the port 9 register configuration. Port 9 is an input-only port, and does not have a data direction register or data register.

**Table 10A-9 Port 9 Registers**

Name	Abbreviation	R/W	Initial Value	Address*
Port 9 register	PORT9	R	Undefined	H'FFB8

Note: \* Lower 16 bits of the address.

**Port 9 Register (PORT9):** The pin states are always read when a port 9 read is performed.

Bit	:	7	6	5	4	3	2	1	0
		P97	P96	P95	P94	P93	P92	P91	P90
Initial value :		—*	—*	—*	—*	—*	—*	—*	—*
R/W	:	R	R	R	R	R	R	R	R

Note: \* Determined by state of pins P97 to P90.

### 10A.6.3 Pin Functions

Port 9 pins are multipurpose pins which function as A/D converter analog input pins (AN8 to AN15) and D/A converter analog output pins (DA2 and DA3).

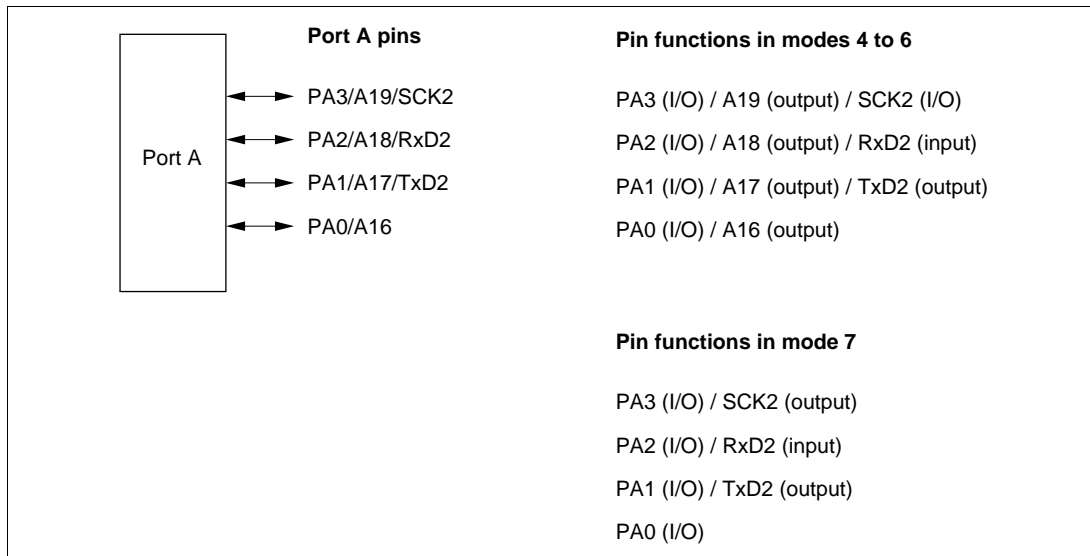
## 10A.7 Port A

### 10A.7.1 Overview

Port A is a 4-bit I/O port. Port A pins also function as address bus outputs and SCI2 I/O pins (SCK2, RxD2, and TxD2). The pin functions change according to the operating mode.

Port A has a built-in MOS input pull-up function that can be controlled by software.

Figure 10A-6 shows the port A pin configuration.



**Figure 10A-6 Port A Pin Functions**

## 10A.7.2 Register Configuration

Table 10A-10 shows the port A register configuration.

**Table 10A-10 Port A Registers**

Name	Abbreviation	R/W	Initial Value* <sup>2</sup>	Address* <sup>1</sup>
Port A data direction register	PADDR	W	H'0	H'FE39
Port A data register	PADR	R/W	H'0	H'FF09
Port A register	PORTA	R	Undefined	H'FFB9
Port A MOS pull-up control register	PAPCR	R/W	H'0	H'FE40
Port A open-drain control register	PAODR	R/W	H'0	H'FE47

Notes: \*1 Lower 16 bits of the address.

\*2 Value of bits 3 to 0.

### Port A Data Direction Register (PADDR)

Bit	7	6	5	4	3	2	1	0
	—	—	—	—	PA3DDR	PA2DDR	PA1DDR	PA0DDR
Initial value :	Undefined	Undefined	Undefined	Undefined	0	0	0	0
R/W :	—	—	—	—	W	W	W	W

PADDR is an 8-bit write-only register, the individual bits of which specify input or output for the pins of port A. PADDR cannot be read; if it is, an undefined value will be read.

Bits 7 and 6 are reserved; they return an undetermined value if read.

PADDR is initialized to H'0 (bits 3 to 0) by a power-on reset, and in hardware standby mode. It retains its prior state by a manual reset or in software standby mode. The OPE bit in SBYCR is used to select whether the address output pins retain their output state or become high-impedance when a transition is made to software standby mode.

- Modes 4 to 6

The corresponding port A pins become address outputs in accordance with the setting of bits AE3 to AE0 in PFCR, irrespective of the value of bits PA4DDR to PA0DDR. When pins are not used as address outputs, setting a PADDR bit to 1 makes the corresponding port A pin an output port, while clearing the bit to 0 makes the pin an input port.

- Mode 7

Setting a PADDR bit to 1 makes the corresponding port A pin an output port, while clearing the bit to 0 makes the pin an input port.

### Port A Data Register (PADR)

Bit	:	7	6	5	4	3	2	1	0
		—	—	—	—	PA3DR	PA2DR	PA1DR	PA0DR
Initial value	:	Undefined	Undefined	Undefined	Undefined	0	0	0	0
R/W	:	—	—	—	—	R/W	R/W	R/W	R/W

PADR is an 8-bit readable/writable register that stores output data for the port A pins (PA7 to PA0).

Bits 7 to 4 are reserved; they return an undetermined value if read, and cannot be modified.

PADR is initialized to H'0 (bits 3 to 0) by a power-on reset, and in hardware standby mode. It retains its prior state by a manual reset or in software standby mode.

### Port A Register (PORTA)

Bit	:	7	6	5	4	3	2	1	0
		—	—	—	—	PA3	PA2	PA1	PA0
Initial value	:	Undefined	Undefined	Undefined	Undefined	—*	—*	—*	—*
R/W	:	—	—	—	—	R	R	R	R

Note: \* Determined by state of pins PA3 to PA0.

PORTA is an 8-bit read-only register that shows the pin states. It cannot be written to. Writing of output data for the port A pins (PA7 to PA0) must always be performed on PADR.

Bits 7 to 4 are reserved; they return an undetermined value if read, and cannot be modified.

If a port A read is performed while PADDR bits are set to 1, the PADR values are read. If a port A read is performed while PADDR bits are cleared to 0, the pin states are read.

After a power-on reset and in hardware standby mode, PORTA contents are determined by the pin states, as PADDR and PADR are initialized. PORTA retains its prior state by a manual reset or in software standby mode.

### Port A MOS Pull-Up Control Register (PAPCR)

Bit	:	7	6	5	4	3	2	1	0
		—	—	—	—	PA3PCR	PA2PCR	PA1PCR	PA0PCR
Initial value	:	Undefined	Undefined	Undefined	Undefined	0	0	0	0
R/W	:	—	—	—	—	R/W	R/W	R/W	R/W

PAPCR is an 8-bit readable/writable register that controls the MOS input pull-up function incorporated into port A on an individual bit basis.

Bits 7 to 4 are reserved; they return an undetermined value if read, and cannot be modified. In modes 4 to 6, if a pin is in the input state in accordance with the settings in PFCR, in the SCI's SCMR, SMR, and SCR, and in DDR, setting the corresponding PAPCR bit to 1 turns on the MOS input pull-up for that pin.

In mode 7, if a pin is in the input state in accordance with the settings in the SCI's SCMR, SMR, and SCR, and in DDR, setting the corresponding PAPCR bit to 1 turns on the MOS input pull-up for that pin.

PAPCR is initialized by a manual reset or to H'0 (bits 3 to 0) by a power-on reset, and in hardware standby mode. It retains its prior state in software standby mode.

### Port A Open Drain Control Register (PAODR)

Bit	:	7	6	5	4	3	2	1	0
		—	—	—	—	PA3ODR	PA2ODR	PA1ODR	PA0ODR
Initial value	:	Undefined	Undefined	Undefined	Undefined	0	0	0	0
R/W	:	—	—	—	—	R/W	R/W	R/W	R/W

PAODR is an 8-bit readable/writable register that controls whether PMOS is on or off for each port A pin (PA7 to PA0).

Bits 7 to 4 are reserved; they return an undetermined value if read, and cannot be modified.

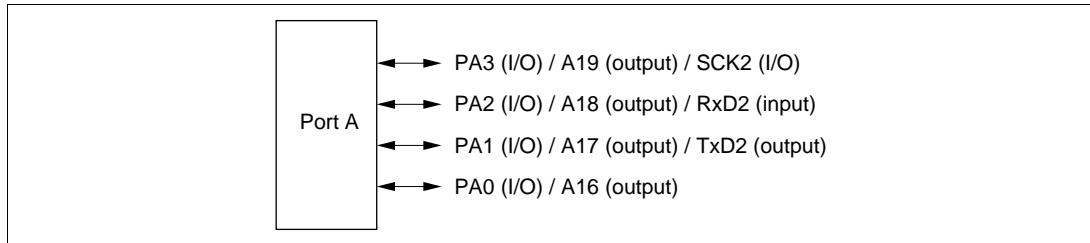
When pins are not address outputs in accordance with the setting of bits AE3 to AE0 in PFCR, setting a PAODR bit makes the corresponding port A pin an NMOS open-drain output, while clearing the bit to 0 makes the pin a CMOS output.

PAODR is initialized to H'0 (bits 3 to 0) by a power-on reset, and in hardware standby mode. It retains its prior state by a manual reset or in software standby mode.

### 10A.7.3 Pin Functions

**Modes 4 to 6:** In modes 4 to 6, port A pins function as address outputs according to the setting of AE3 to AE0 in PFCR; when they do not function as address outputs, the pins function as SCI I/O pins and I/O ports.

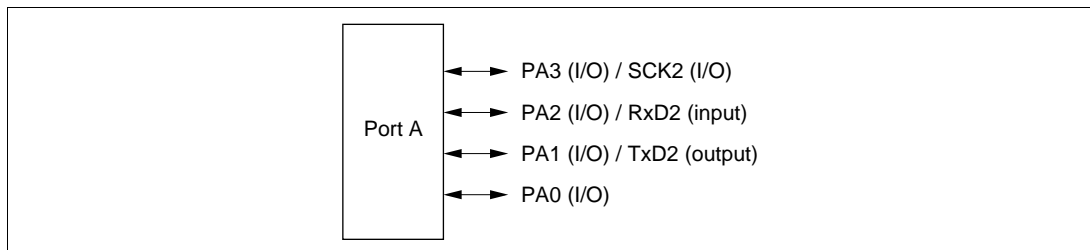
Port A pin functions in modes 4 to 6 are shown in figure 10A-7.



**Figure 10A-7 Port A Pin Functions (Modes 4 to 6)**

**Mode 7:** In mode 7, port A pins function as I/O ports and SCI2 I/O pins (SCK2, TxD2, and RxD2). Input or output can be specified for each pin on an individual bit basis. Setting a PADDR bit to 1 makes the corresponding port A pin an output port, while clearing the bit to 0 makes the pin an input port.

Port A pin functions are shown in figure 10A-8.



**Figure 10A-8 Port A Pin Functions (Mode 7)**

### 10A.7.4 MOS Input Pull-Up Function

Port A has a built-in MOS input pull-up function that can be controlled by software. MOS input pull-up can be specified as on or off on an individual bit basis.

In modes 4 to 6, if a pin is in the input state in accordance with the settings in PFCR, in the SCI's SCMR, SMR, and SCR, and in DDR, setting the corresponding PAPCR bit to 1 turns on the MOS input pull-up for that pin.

In mode 7, if a pin is in the input state in accordance with the settings in the SCI's SCMR, SMR, and SCR, and in DDR, setting the corresponding PAPCR bit to 1 turns on the MOS input pull-up for that pin.

The MOS input pull-up function is in the off state after a power-on reset, and in hardware standby mode. The prior state is retained by a manual reset or in software standby mode.

Table 10A-11 summarizes the MOS input pull-up states.

**Table 10A-11 MOS Input Pull-Up States (Port A)**

<b>Pin States</b>	<b>Power-On Reset</b>	<b>Hardware Standby Mode</b>	<b>Manual Reset</b>	<b>Software Standby Mode</b>	<b>In Other Operations</b>
Address output or SCI output	OFF	OFF	OFF	OFF	OFF
Other than above			ON/OFF	ON/OFF	ON/OFF

**Legend:**

OFF : MOS input pull-up is always off.

ON/OFF : On when PADDR = 0 and PAPCR = 1; otherwise off.



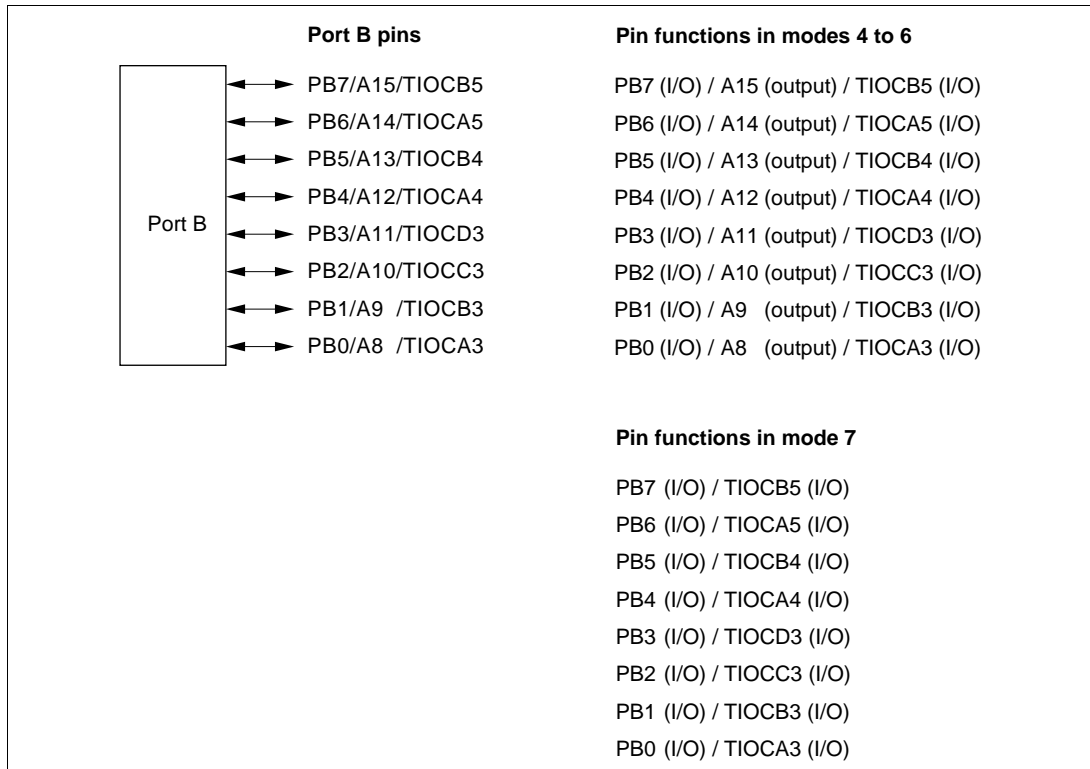
## 10A.8 Port B

### 10A.8.1 Overview

Port B is an 8-bit I/O port. Port B pins also function as TPU I/O pins (TIOCA3, TIOCB3, TIOCC3, TIOCD3, TIOCA4, TIOCB4, TIOCA5, and TIOCB5) and as address outputs; the pin functions change according to the operating mode.

Port B has a built-in MOS input pull-up function that can be controlled by software.

Figure 10A-9 shows the port B pin configuration.



**Figure 10A-9 Port B Pin Functions**

## 10A.8.2 Register Configuration

Table 10A-12 shows the port B register configuration.

**Table 10A-12 Port B Registers**

Name	Abbreviation	R/W	Initial Value	Address*
Port B data direction register	PBDDR	W	H'00	H'FE3A
Port B data register	PBDR	R/W	H'00	H'FF0A
Port B register	PORTB	R	Undefined	H'FFBA
Port B MOS pull-up control register	PBPCR	R/W	H'00	H'FE41
Port B open-drain control register	PBODR	R/W	H'00	H'FE48

Note: \* Lower 16 bits of the address.

### Port B Data Direction Register (PBDDR)

Bit	:	7	6	5	4	3	2	1	0
		PB7DDR	PB6DDR	PB5DDR	PB4DDR	PB3DDR	PB2DDR	PB1DDR	PB0DDR
Initial value :		0	0	0	0	0	0	0	0
R/W :		W	W	W	W	W	W	W	W

PBDDR is an 8-bit write-only register, the individual bits of which specify input or output for the pins of port B. PBDDR cannot be read; if it is, an undefined value will be read.

PBDDR is initialized to H'00 by a power-on reset, and in hardware standby mode. It retains its prior state by a manual reset or in software standby mode. The OPE bit in SBYCR is used to select whether the address output pins retain their output state or become high-impedance when a transition is made to software standby mode.

- Modes 4 to 6

The corresponding port B pins become address outputs in accordance with the setting of bits AE3 to AE0 in PFCR, irrespective of the value of the PBDDR bits. When pins are not used as address outputs, setting a PBDDR bit to 1 makes the corresponding port B pin an output port, while clearing the bit to 0 makes the pin an input port.

- Mode 7

Setting a PBDDR bit to 1 makes the corresponding port B pin an output port, while clearing the bit to 0 makes the pin an input port.

### Port B Data Register (PBDR)

Bit	:	7	6	5	4	3	2	1	0
		PB7DR	PB6DR	PB5DR	PB4DR	PB3DR	PB2DR	PB1DR	PB0DR
Initial value :		0	0	0	0	0	0	0	0
R/W	:	R/W	R/W	R/W	R/W	R/W	R/W	R/W	R/W

PBDR is an 8-bit readable/writable register that stores output data for the port B pins (PB7 to PB0). PBDR is initialized to H'00 by a power-on reset, and in hardware standby mode. It retains its prior state by a manual reset or in software standby mode.

### Port B Register (PORTB)

Bit	:	7	6	5	4	3	2	1	0
		PB7	PB6	PB5	PB4	PB3	PB2	PB1	PB0
Initial value :		—*	—*	—*	—*	—*	—*	—*	—*
R/W	:	R	R	R	R	R	R	R	R

Note: \* Determined by state of pins PB7 to PB0.

PORTB is an 8-bit read-only register that shows the pin states. It cannot be written to. Writing of output data for the port B pins (PB7 to PB0) must always be performed on PBDR.

If a port B read is performed while PBDDR bits are set to 1, the PBDR values are read. If a port B read is performed while PBDDR bits are cleared to 0, the pin states are read.

After a power-on reset and in hardware standby mode, PORTB contents are determined by the pin states, as PBDDR and PBDR are initialized. PORTB retains its prior state in software standby mode.

### Port B MOS Pull-Up Control Register (PBPCR)

Bit	:	7	6	5	4	3	2	1	0
		PB7PCR	PB6PCR	PB5PCR	PB4PCR	PB3PCR	PB2PCR	PB1PCR	PB0PCR
Initial value :		0	0	0	0	0	0	0	0
R/W	:	R/W	R/W	R/W	R/W	R/W	R/W	R/W	R/W

PBPCR is an 8-bit readable/writable register that controls the MOS input pull-up function incorporated into port B on an individual bit basis.

In modes 4 to 6, if a pin is in the input state in accordance with the settings in PFCR, in the TPU's TIOR, and in DDR, setting the corresponding PBPCR bit to 1 turns on the MOS input pull-up for that pin.

In mode 7, if a pin is in the input state in accordance with the settings in the TPU's TIOR and in DDR, setting the corresponding PBPCR bit to 1 turns on the MOS input pull-up for that pin.

PBPCR is initialized to H'00 by a power-on reset, and in hardware standby mode. It retains its prior state by a manual reset or in software standby mode.

### Port B Open Drain Control Register (PBODR)

Bit	:	7	6	5	4	3	2	1	0
		PB7ODR	PB6ODR	PB5ODR	PB4ODR	PB3ODR	PB2ODR	PB1ODR	PB0ODR
Initial value :		0	0	0	0	0	0	0	0
R/W	:	R/W	R/W	R/W	R/W	R/W	R/W	R/W	R/W

PBODR is an 8-bit readable/writable register that controls the PMOS on/off state for each port B pin (PB7 to PB0).

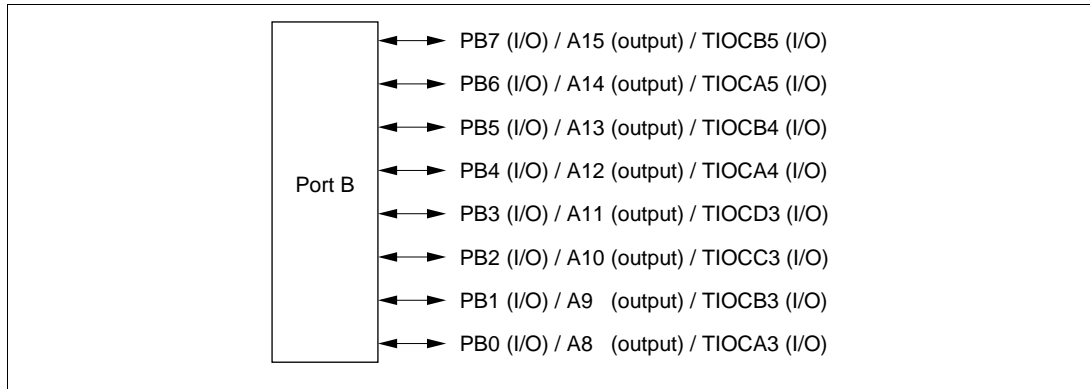
When pins are not address outputs in accordance with the setting of bits AE3 to AE0 in PFCR, setting a PBODR bit makes the corresponding port B pin an NMOS open-drain output, while clearing the bit to 0 makes the pin a CMOS output.

PBODR is initialized to H'00 by a power-on reset, and in hardware standby mode. It retains its prior state by a manual reset or in software standby mode.

### 10A.8.3 Pin Functions

**Modes 4 to 6:** In modes 4 to 6, the corresponding port B pins become address outputs in accordance with the setting of bits AE3 to AE0 in PFCR. When pins are not used as address outputs, they function as TPU I/O pins and I/O ports.

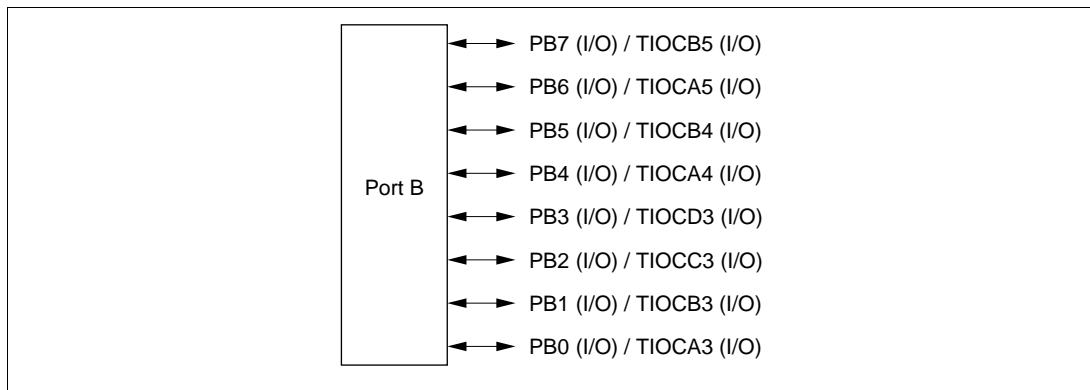
Port B pin functions in modes 4 to 6 are shown in figure 10A-10.



**Figure 10A-10 Port B Pin Functions (Modes 4 to 6)**

**Mode 7:** In mode 7, port B pins function as I/O ports and TPU I/O pins (TIOCA3, TIOCB3, TIOCC3, TIOCD3, TIOCA4, TIOCB4, TIOCA5, and TIOCB5). Input or output can be specified for each pin on an individual bit basis. Setting a PBDDR bit to 1 makes the corresponding port B pin an output port, while clearing the bit to 0 makes the pin an input port.

Port B pin functions in mode 7 are shown in figure 10A-11.



**Figure 10A-11 Port B Pin Functions (Mode 7)**

#### 10A.8.4 MOS Input Pull-Up Function

Port B has a built-in MOS input pull-up function that can be controlled by software. MOS input pull-up can be specified as on or off on an individual bit basis.

In modes 4 to 6, if a pin is in the input state in accordance with the settings in PFCR, in the TPU's TIOR, and in DDR, setting the corresponding PBPCR bit to 1 turns on the MOS input pull-up for that pin.

In mode 7, if a pin is in the input state in accordance with the settings in the TPU's TIOR and in DDR, setting the corresponding PBPCR bit to 1 turns on the MOS input pull-up for that pin.

The MOS input pull-up function is in the off state after a power-on reset, and in hardware standby mode. The prior state is retained by a manual reset or in software standby mode.

Table 10A-13 summarizes the MOS input pull-up states.

**Table 10A-13 MOS Input Pull-Up States (Port B)**

Pin States	Power-On Reset	Hardware Standby Mode	Manual Reset	Software Standby Mode	In Other Operations
Address output or TPU output	OFF	OFF	OFF	OFF	OFF
Other than above			ON/OFF	ON/OFF	ON/OFF

**Legend:**

OFF : MOS input pull-up is always off.

ON/OFF : On when PBDDR = 0 and PBPCR = 1; otherwise off.

## 10A.9 Port C

### 10A.9.1 Overview

Port C is an 8-bit I/O port. Port C has a 14-bit PWM output (PWM0 and PWM1) and an address bus output function. The pin functions change according to the operating mode.

Port C has a built-in MOS input pull-up function that can be controlled by software.

Figure 10A-12 shows the port C pin configuration.

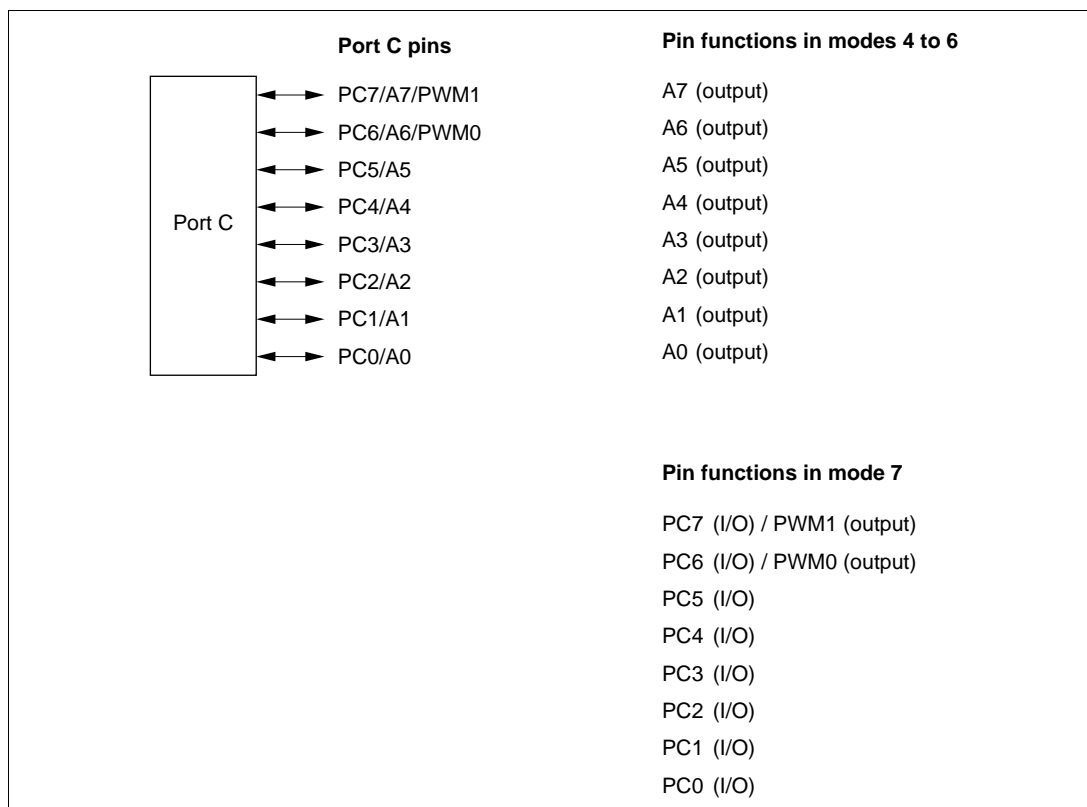


Figure 10A-12 Port C Pin Functions

## 10A.9.2 Register Configuration

Table 10A-14 shows the port C register configuration.

**Table 10A-14 Port C Registers**

Name	Abbreviation	R/W	Initial Value	Address*
Port C data direction register	PCDDR	W	H'00	H'FE3B
Port C data register	PCDR	R/W	H'00	H'FF0B
Port C register	PORTC	R	Undefined	H'FFBB
Port C MOS pull-up control register	PCPCR	R/W	H'00	H'FE42
Port C open-drain control register	PCODR	R/W	H'00	H'FE49

Note: \* Lower 16 bits of the address.

### Port C Data Direction Register (PCDDR)

Bit	:	7	6	5	4	3	2	1	0
		PC7DDR	PC6DDR	PC5DDR	PC4DDR	PC3DDR	PC2DDR	PC1DDR	PC0DDR
Initial value :		0	0	0	0	0	0	0	0
R/W	:	W	W	W	W	W	W	W	W

PCDDR is an 8-bit write-only register, the individual bits of which specify input or output for the pins of port C. PCDDR cannot be read; if it is, an undefined value will be read.

PCDDR is initialized to H'00 by a power-on reset, and in hardware standby mode. It retains its prior state by a manual reset or in software standby mode. The OPE bit in SBYCR is used to select whether the address output pins retain their output state or become high-impedance when the mode is changed to software standby mode.

- Modes 4 and 5  
The corresponding port C pins are address outputs irrespective of the value of the PCDDR bits.
- Mode 6  
Setting a PCDDR bit to 1 makes the corresponding port C pin an address output, while clearing the bit to 0 makes the pin an input port.
- Mode 7  
Setting a PCDDR bit to 1 makes the corresponding port C pin an output port, while clearing the bit to 0 makes the pin an input port.



### Port C Data Register (PCDR)

Bit	:	7	6	5	4	3	2	1	0
		PC7DR	PC6DR	PC5DR	PC4DR	PC3DR	PC2DR	PC1DR	PC0DR
Initial value :		0	0	0	0	0	0	0	0
R/W	:	R/W	R/W	R/W	R/W	R/W	R/W	R/W	R/W

PCDR is an 8-bit readable/writable register that stores output data for the port C pins (PC7 to PC0).

PCDR is initialized to H'00 by a power-on reset, and in hardware standby mode. It retains its prior state by a manual reset or in software standby mode.

### Port C Register (PORTC)

Bit	:	7	6	5	4	3	2	1	0
		PC7	PC6	PC5	PC4	PC3	PC2	PC1	PC0
Initial value :		—*	—*	—*	—*	—*	—*	—*	—*
R/W	:	R	R	R	R	R	R	R	R

Note: \* Determined by state of pins PC7 to PC0.

PORTC is an 8-bit read-only register that shows the pin states. It cannot be written to. Writing of output data for the port C pins (PC7 to PC0) must always be performed on PCDR.

If a port C read is performed while PCDDR bits are set to 1, the PCDR values are read. If a port C read is performed while PCDDR bits are cleared to 0, the pin states are read.

After a power-on reset and in hardware standby mode, PORTC contents are determined by the pin states, as PCDDR and PCDR are initialized. PORTC retains its prior state by a manual reset or in software standby mode.

### Port C MOS Pull-Up Control Register (PCPCR)

Bit	:	7	6	5	4	3	2	1	0
		PC7PCR	PC6PCR	PC5PCR	PC4PCR	PC3PCR	PC2PCR	PC1PCR	PC0PCR
Initial value :		0	0	0	0	0	0	0	0
R/W	:	R/W	R/W	R/W	R/W	R/W	R/W	R/W	R/W

PCPCR is an 8-bit readable/writable register that controls the MOS input pull-up function incorporated into port C on an individual bit basis.

In modes 6 and 7, if PCPCR is set to 1 when the port is in the input state in accordance with the settings of DACR and PCDDR in PWM, the MOS input pull-up is set to ON.

PCPCR is initialized to H'00 by a power-on reset, and in hardware standby mode. It retains its prior state by a manual reset or in software standby mode.

### Port C Open Drain Control Register (PCODR)

Bit	:	7	6	5	4	3	2	1	0
		PC7ODR	PC6ODR	PC5ODR	PC4ODR	PC3ODR	PC2ODR	PC1ODR	PC0ODR
Initial value :		0	0	0	0	0	0	0	0
R/W	:	R/W	R/W	R/W	R/W	R/W	R/W	R/W	R/W

PCDDR is an 8-bit read/write register and controls PMOS on/off of each pin (PC7 to PC0) of port C.

If PCODR is set to 1 by setting AE3 to AE0 in PFCR in mode other than address output mode, port C pins function as NMOS open drain outputs and when the setting is cleared to 0, the pins function as CMOS outputs.

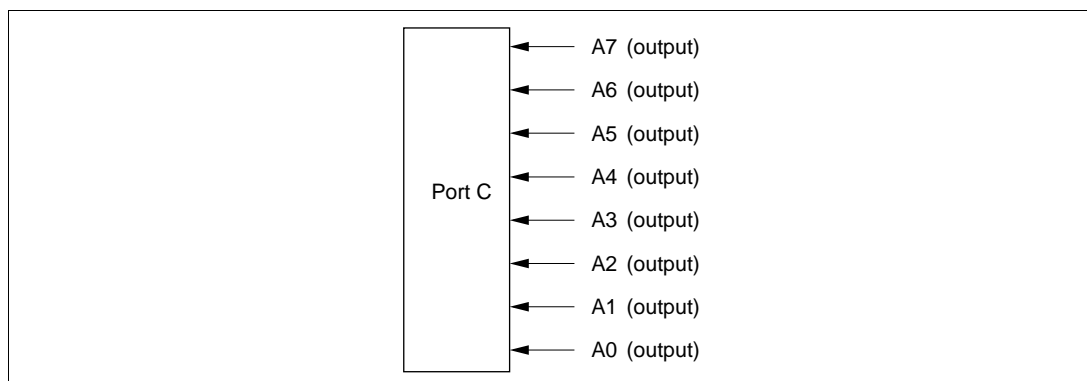
PCODR is initialized to H'00 in power-on reset mode or hardware standby mode. PCODR retains the last state in manual reset mode or software standby mode.

### 10A.9.3 Pin Functions for Each Mode

#### (1) Modes 4 and 5

In modes 4 and 5, port C pins function as address outputs automatically.

Figure 10A-13 shows the port C pin functions.

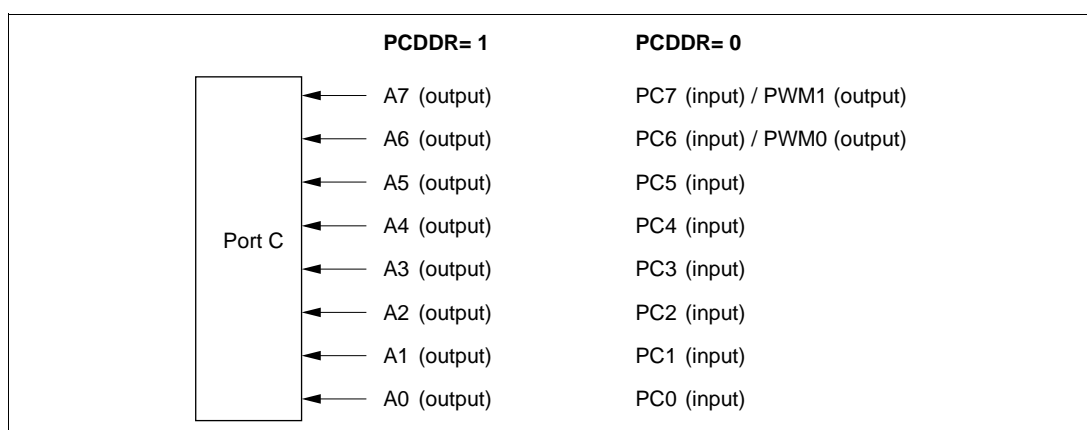


**Figure 10A-13 Port C Pin Functions (Modes 4 and 5)**

#### (2) Mode 6

In mode 6, port C pins function as address outputs or input ports and I/O can be specified in bit units. When each bit in PCDDR is set to 1, the corresponding pin functions as an address output and when the bit cleared to 0, the pin functions as a PWM output and an input port.

Figure 10A-14 shows the port C pin functions.

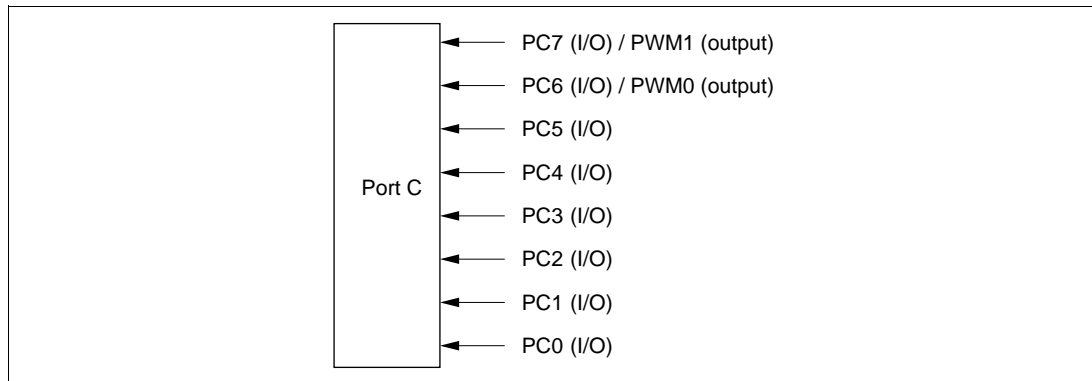


**Figure 10A-14 Port C Pin Functions (Mode 6)**

### (3) Mode 7

In mode 7, port C pins function as PWM outputs and I/O ports and I/O can be specified for each pin in bit units. When each bit in PCDDR is set to 1, the corresponding pin functions as an output port and when the bit is cleared to 0, the pin functions as an input port.

Figure 10A-15 shows the port C pin functions.



**Figure 10A-15 Port C Pin Functions (Mode 7)**

#### 10A.9.4 MOS Input Pull-Up Function

Port C has a built-in MOS input pull-up function that can be controlled by software. This MOS input pull-up function can be used in modes 6 and 7, and can be specified as on or off on an individual bit basis.

In modes 6 and 7, when PCPCR is set to 1 in the input state by setting of DACR and PCDDR, the MOS input pull-up is set to ON.

The MOS input pull-up function is in the off state after a power-on reset, and in hardware standby mode. The prior state is retained by a manual reset or in software standby mode.

Table 10A-15 summarizes the MOS input pull-up states.

**Table 10A-15 MOS Input Pull-Up States (Port C)**

<b>Pin States</b>	<b>Power-On Reset</b>	<b>Hardware Standby Mode</b>	<b>Manual Reset</b>	<b>Software Standby Mode</b>	<b>In Other Operations</b>
Address output or PWM output	OFF	OFF	OFF	OFF	OFF
Other than above			ON/OFF	ON/OFF	ON/OFF

**Legend:**

OFF : MOS input pull-up is always off.

ON/OFF : On when PCDDR = 0 and PCPCR = 1; otherwise off.

## 10A.10 Port D

### 10A.10.1 Overview

Port D is an 8-bit I/O port. Port D has a data bus I/O function, and the pin functions change according to the operating mode.

Port D has a built-in MOS input pull-up function that can be controlled by software.

Figure 10A-16 shows the port D pin configuration.

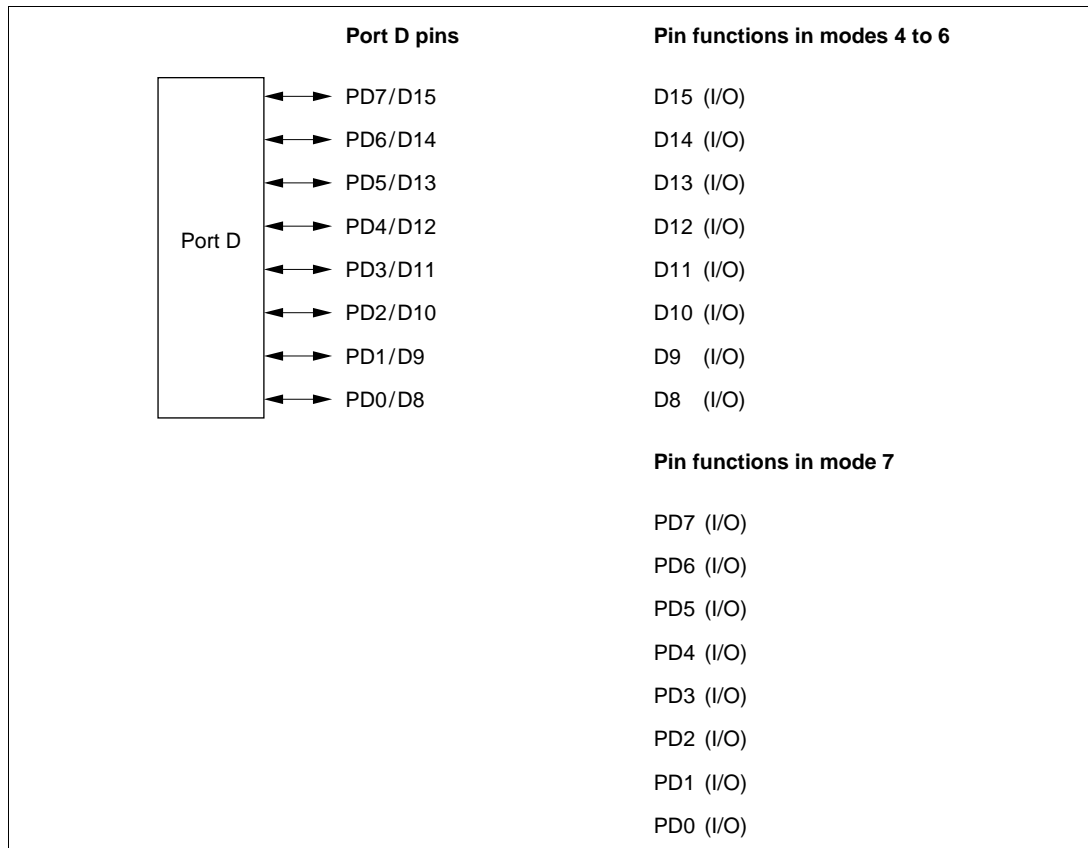


Figure 10A-16 Port D Pin Functions

### 10A.10.2 Register Configuration

Table 10A-16 shows the port D register configuration.

**Table 10A-16 Port D Registers**

Name	Abbreviation	R/W	Initial Value	Address*
Port D data direction register	PDDDR	W	H'00	H'FE3C
Port D data register	PDDR	R/W	H'00	H'FF0C
Port D register	PORTD	R	Undefined	H'FFBC
Port D MOS pull-up control register	PDPCR	R/W	H'00	H'FE43

Note: \* Lower 16 bits of the address.

#### Port D Data Direction Register (PDDDR)

Bit	:	7	6	5	4	3	2	1	0
		PD7DDR	PD6DDR	PD5DDR	PD4DDR	PD3DDR	PD2DDR	PD1DDR	PD0DDR
Initial value :		0	0	0	0	0	0	0	0
R/W	:	W	W	W	W	W	W	W	W

PDDDR is an 8-bit write-only register, the individual bits of which specify input or output for the pins of port D. PDDDR cannot be read; if it is, an undefined value will be read.

PDDDR is initialized to H'00 by a power-on reset, and in hardware standby mode. It retains its prior state by a manual reset or in software standby mode.

- Modes 4 to 6  
The input/output direction specification by PDDDR is ignored, and port D is automatically designated for data I/O.
- Mode 7  
Setting a PDDDR bit to 1 makes the corresponding port D pin an output port, while clearing the bit to 0 makes the pin an input port.

### Port D Data Register (PDDR)

Bit	:	7	6	5	4	3	2	1	0
		PD7DR	PD6DR	PD5DR	PD4DR	PD3DR	PD2DR	PD1DR	PD0DR
Initial value :		0	0	0	0	0	0	0	0
R/W	:	R/W	R/W	R/W	R/W	R/W	R/W	R/W	R/W

PDDR is an 8-bit readable/writable register that stores output data for the port D pins (PD7 to PD0).

PDDR is initialized to H'00 by a power-on reset, and in hardware standby mode. It retains its prior state by a manual reset or in software standby mode.

### Port D Register (PORTD)

Bit	:	7	6	5	4	3	2	1	0
		PD7	PD6	PD5	PD4	PD3	PD2	PD1	PD0
Initial value :		—*	—*	—*	—*	—*	—*	—*	—*
R/W	:	R	R	R	R	R	R	R	R

Note: \* Determined by state of pins PD7 to PD0.

PORTD is an 8-bit read-only register that shows the pin states. It cannot be written to. Writing of output data for the port D pins (PD7 to PD0) must always be performed on PDDR.

If a port D read is performed while PDDDR bits are set to 1, the PDDR values are read. If a port D read is performed while PDDDR bits are cleared to 0, the pin states are read.

After a power-on reset and in hardware standby mode, PORTD contents are determined by the pin states, as PDDDR and PDDR are initialized. PORTD retains its prior state by a manual reset or in software standby mode.



### Port D MOS Pull-Up Control Register (PDPCR)

Bit	:	7	6	5	4	3	2	1	0
		PD7PCR	PD6PCR	PD5PCR	PD4PCR	PD3PCR	PD2PCR	PD1PCR	PD0PCR
Initial value :		0	0	0	0	0	0	0	0
R/W	:	R/W	R/W	R/W	R/W	R/W	R/W	R/W	R/W

PDPCR is an 8-bit readable/writable register that controls the MOS input pull-up function incorporated into port D on an individual bit basis.

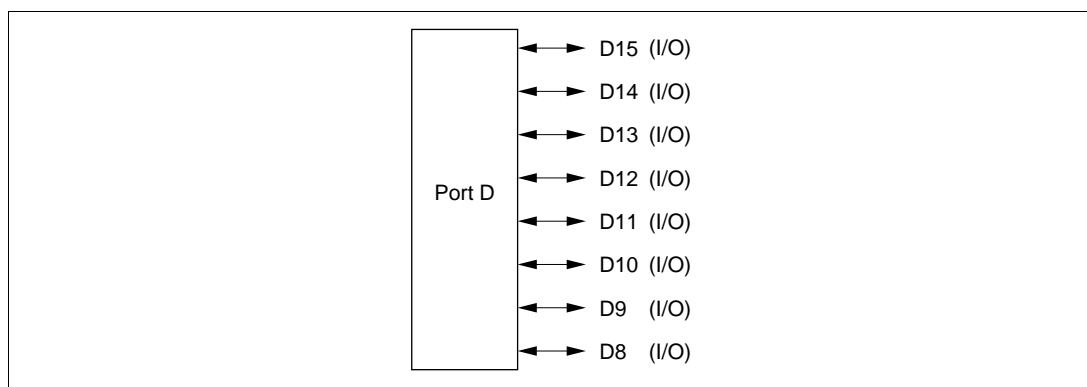
When a PDDDR bit is cleared to 0 (input port setting) in mode 7, setting the corresponding PDPCR bit to 1 turns on the MOS input pull-up for the corresponding pin.

PDPCR is initialized to H'00 by a power-on reset, and in hardware standby mode. It retains its prior state by a manual reset or in software standby mode.

#### 10A.10.3 Pin Functions

**Modes 4 to 6:** In modes 4 to 6, port D pins are automatically designated as data I/O pins.

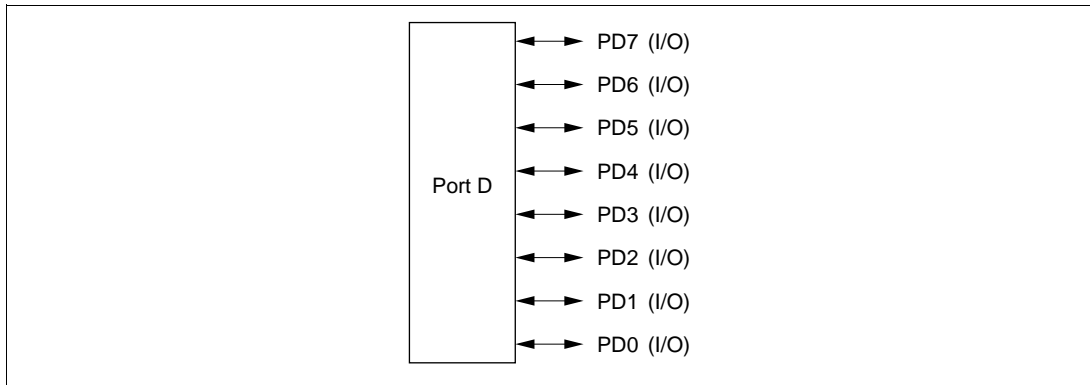
Port D pin functions in modes 4 to 6 are shown in figure 10A-17.



**Figure 10A-17 Port D Pin Functions (Modes 4 to 6)**

**Mode 7:** In mode 7, port D pins function as I/O ports. Input or output can be specified for each pin on an individual bit basis. Setting a PDDDR bit to 1 makes the corresponding port D pin an output port, while clearing the bit to 0 makes the pin an input port.

Port D pin functions in mode 7 are shown in figure 10A-18.



**Figure 10A-18 Port D Pin Functions (Mode 7)**

#### 10A.10.4 MOS Input Pull-Up Function

Port D has a built-in MOS input pull-up function that can be controlled by software. This MOS input pull-up function can be used in mode 7, and can be specified as on or off on an individual bit basis.

When a PDDDR bit is cleared to 0 in mode 7, setting the corresponding PDPCR bit to 1 turns on the MOS input pull-up for that pin.

The MOS input pull-up function is in the off state after a power-on reset, and in hardware standby mode. The prior state is retained by a manual reset or in software standby mode.

Table 10A-17 summarizes the MOS input pull-up states.

**Table 10A-17 MOS Input Pull-Up States (Port D)**

Modes	Power-On Reset	Hardware Standby Mode	Manual Reset	Software Standby Mode	In Other Operations
4 to 6	OFF	OFF	OFF	OFF	OFF
7			ON/OFF	ON/OFF	ON/OFF

**Legend:**

OFF : MOS input pull-up is always off.

ON/OFF : On when PDDDR = 0 and PDPCR = 1; otherwise off.

## 10A.11 Port E

### 10A.11.1 Overview

Port E is an 8-bit I/O port. Port E has a data bus I/O function, and the pin functions change according to the operating mode and whether 8-bit or 16-bit bus mode is selected.

Port E has a built-in MOS input pull-up function that can be controlled by software.

Figure 10A-19 shows the port E pin configuration.

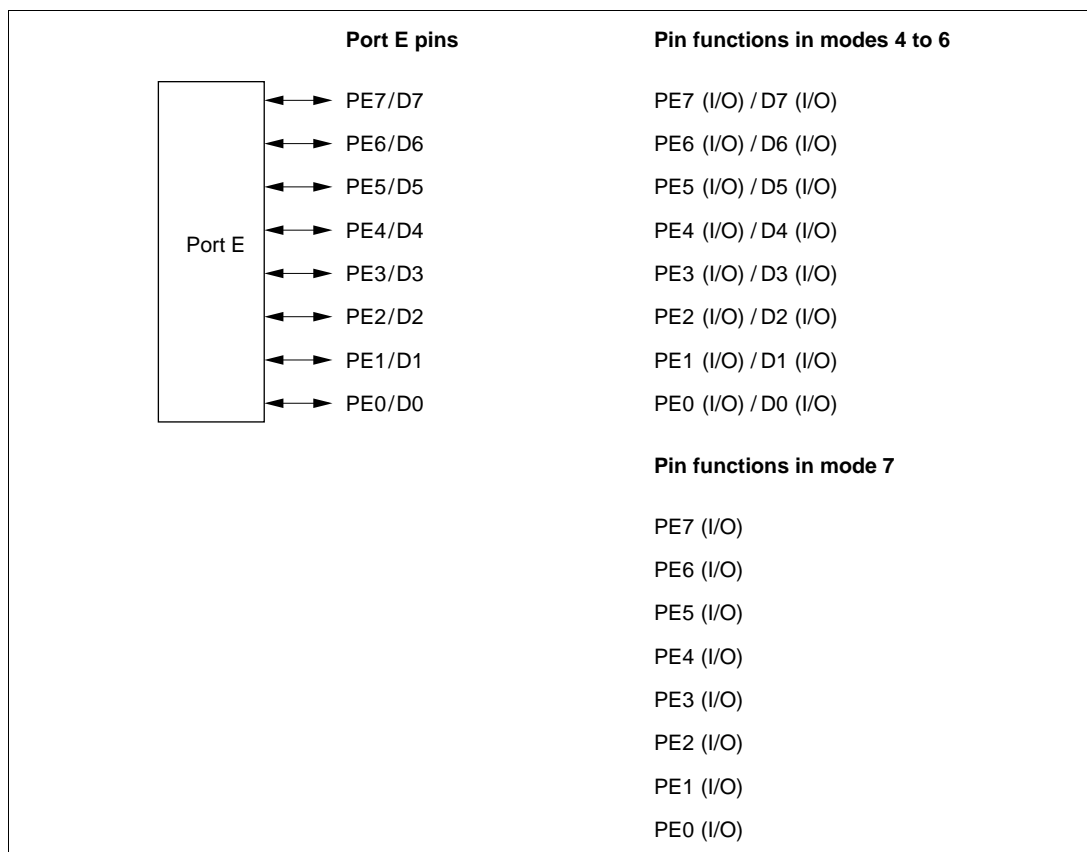


Figure 10A-19 Port E Pin Functions

### 10A.11.2 Register Configuration

Table 10A-18 shows the port E register configuration.

**Table 10A-18 Port E Registers**

Name	Abbreviation	R/W	Initial Value	Address*
Port E data direction register	PEDDR	W	H'00	H'FE3D
Port E data register	PEDR	R/W	H'00	H'FF0D
Port E register	PORTE	R	Undefined	H'FFBD
Port E MOS pull-up control register	PEPCR	R/W	H'00	H'FE44

Note: \* Lower 16 bits of the address.

#### Port E Data Direction Register (PEDDR)

Bit	:	7	6	5	4	3	2	1	0
		PE7DDR	PE6DDR	PE5DDR	PE4DDR	PE3DDR	PE2DDR	PE1DDR	PE0DDR
Initial value	:	0	0	0	0	0	0	0	0
R/W	:	W	W	W	W	W	W	W	W

PEDDR is an 8-bit write-only register, the individual bits of which specify input or output for the pins of port E. PEDDR cannot be read; if it is, an undefined value will be read.

PEDDR is initialized to H'00 by a power-on reset, and in hardware standby mode. It retains its prior state by a manual reset or in software standby mode.

- Modes 4 to 6  
When 8-bit bus mode has been selected, port E pins function as I/O ports. Setting a PEDDR bit to 1 makes the corresponding port E pin an output port, while clearing the bit to 0 makes the pin an input port.  
When 16-bit bus mode has been selected, the input/output direction specification by PEDDR is ignored, and port E is designated for data I/O.  
For details of 8-bit and 16-bit bus modes, see section 7, Bus Controller.
- Mode 7  
Setting a PEDDR bit to 1 makes the corresponding port E pin an output port, while clearing the bit to 0 makes the pin an input port.

### Port E Data Register (PEDR)

Bit	:	7	6	5	4	3	2	1	0
		PE7DR	PE6DR	PE5DR	PE4DR	PE3DR	PE2DR	PE1DR	PE0DR
Initial value :		0	0	0	0	0	0	0	0
R/W	:	R/W	R/W	R/W	R/W	R/W	R/W	R/W	R/W

PEDR is an 8-bit readable/writable register that stores output data for the port E pins (PE7 to PE0).

PEDR is initialized to H'00 by a power-on reset, and in hardware standby mode. It retains its prior state by a manual reset or in software standby mode.

### Port E Register (PORTE)

Bit	:	7	6	5	4	3	2	1	0
		PE7	PE6	PE5	PE4	PE3	PE2	PE1	PE0
Initial value :		—*	—*	—*	—*	—*	—*	—*	—*
R/W	:	R	R	R	R	R	R	R	R

Note: \* Determined by state of pins PE7 to PE0.

PORTE is an 8-bit read-only register that shows the pin states. It cannot be written to. Writing of output data for the port E pins (PE7 to PE0) must always be performed on PEDR.

If a port E read is performed while PEDDR bits are set to 1, the PEDR values are read. If a port E read is performed while PEDDR bits are cleared to 0, the pin states are read.

After a power-on reset and in hardware standby mode, PORTE contents are determined by the pin states, as PEDDR and PEDR are initialized. PORTE retains its prior state by a manual reset or in software standby mode.

### Port E MOS Pull-Up Control Register (PEPCR)

Bit	:	7	6	5	4	3	2	1	0
		PE7PCR	PE6PCR	PE5PCR	PE4PCR	PE3PCR	PE2PCR	PE1PCR	PE0PCR
Initial value	:	0	0	0	0	0	0	0	0
R/W	:	R/W	R/W	R/W	R/W	R/W	R/W	R/W	R/W

PEPCR is an 8-bit readable/writable register that controls the MOS input pull-up function incorporated into port E on an individual bit basis.

When a PEDDR bit is cleared to 0 (input port setting) with 8-bit bus mode selected in modes 4, 5, or 6, or in mode 7, setting the corresponding PEPCR bit to 1 turns on the MOS input pull-up for the corresponding pin.

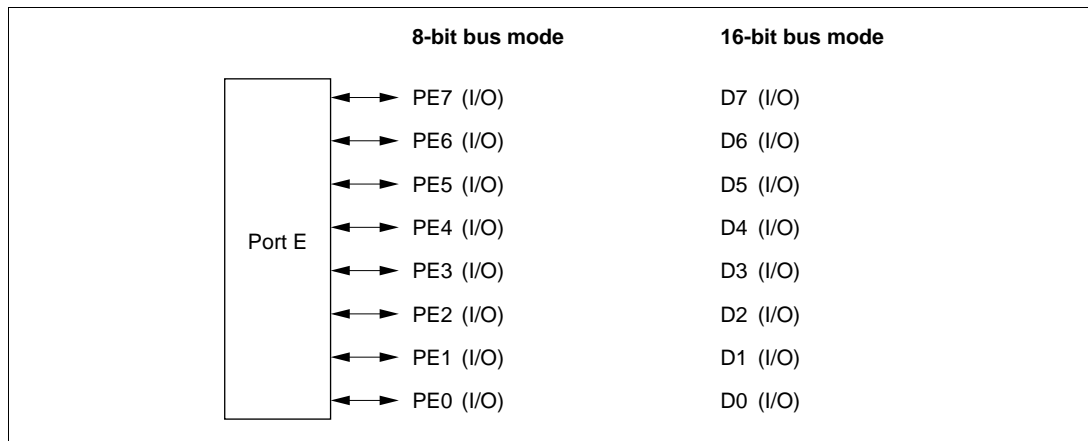
PEPCR is initialized to H'00 by a power-on reset, and in hardware standby mode. It retains its prior state by a manual reset or in software standby mode.

#### 10A.11.3 Pin Functions

**Modes 4 to 6:** In modes 4 to 6, when 8-bit access is designated and 8-bit bus mode is selected, port E pins are automatically designated as I/O ports. Setting a PEDDR bit to 1 makes the corresponding port E pin an output port, while clearing the bit to 0 makes the pin an input port.

When 16-bit bus mode is selected, the input/output direction specification by PEDDR is ignored, and port E is designated for data I/O.

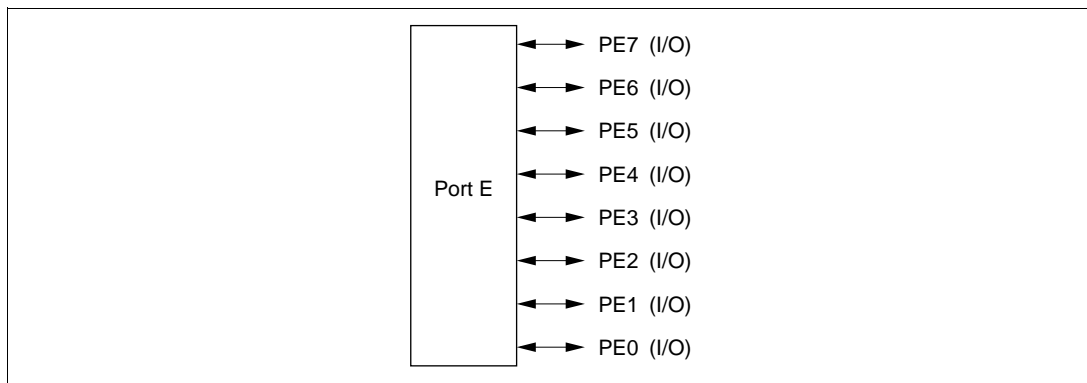
Port E pin functions in modes 4 to 6 are shown in figure 10A-20.



**Figure 10A-20 Port E Pin Functions (Modes 4 to 6)**

**Mode 7:** In mode 7, port E pins function as I/O ports. Input or output can be specified for each pin on a bit-by-bit basis. Setting a PEDDR bit to 1 makes the corresponding port E pin an output port, while clearing the bit to 0 makes the pin an input port.

Port E pin functions in mode 7 are shown in figure 10A-21.



**Figure 10A-21 Port E Pin Functions (Mode 7)**

#### 10A.11.4 MOS Input Pull-Up Function

Port E has a built-in MOS input pull-up function that can be controlled by software. This MOS input pull-up function can be used in modes 4 to 6 when 8-bit bus mode is selected, or in mode 7, and can be specified as on or off on an individual bit basis.

When a PEDDR bit is cleared to 0 in modes 4 to 6 when 8-bit bus mode is selected, or in mode 7, setting the corresponding PEPCR bit to 1 turns on the MOS input pull-up for that pin.

The MOS input pull-up function is in the off state after a power-on reset, and in hardware standby mode. The prior state is retained by a manual reset or in software standby mode.

Table 10A-19 summarizes the MOS input pull-up states.

**Table 10A-19 MOS Input Pull-Up States (Port E)**

Modes	Power-On Reset	Hardware Standby Mode	Manual Reset	Software Standby Mode	In Other Operations
7	OFF	OFF	ON/OFF	ON/OFF	ON/OFF
4 to 6					
	8-bit bus				
	16-bit bus		OFF	OFF	OFF

**Legend:**

OFF : MOS input pull-up is always off.

ON/OFF : On when PEDDR = 0 and PEPCR = 1; otherwise off.

## 10A.12 Port F

### 10A.12.1 Overview

Port F is an 8-bit I/O port. Port F pins also function as external interrupt input pins ( $\overline{\text{IRQ2}}$  and  $\overline{\text{IRQ3}}$ ), BUZZ output pin, A/D trigger input pin ( $\overline{\text{ADTRG}}$ ), bus control signal input/output pins ( $\overline{\text{AS}}$ ,  $\overline{\text{RD}}$ ,  $\overline{\text{HWR}}$ ,  $\overline{\text{LWR}}$ ,  $\overline{\text{LCAS}}$ ,  $\overline{\text{WAIT}}$ ,  $\overline{\text{BREQO}}$ ,  $\overline{\text{BREQ}}$ , and  $\overline{\text{BACK}}$ ) and the system clock ( $\emptyset$ ) output pin.

Figure 10A-22 shows the port F pin configuration.

Port F pins	Pin functions in modes 4 to 6
PF7/ $\emptyset$	PF7 (input) / $\emptyset$ (output)
PF6/ $\overline{\text{AS}}$ / $\overline{\text{LCAS}}$	$\overline{\text{AS}}$ (output) / $\overline{\text{LCAS}}$ (output)
PF5/ $\overline{\text{RD}}$	$\overline{\text{RD}}$ (output)
PF4/ $\overline{\text{HWR}}$	$\overline{\text{HWR}}$ (output)
PF3/ $\overline{\text{LWR}}$ / $\overline{\text{ADTRG}}$ / $\overline{\text{IRQ3}}$	PF3 (I/O) / $\overline{\text{LWR}}$ (output) / $\overline{\text{ADTRG}}$ (input) / $\overline{\text{IRQ3}}$ (input)
PF2/ $\overline{\text{LCAS}}$ / $\overline{\text{WAIT}}$ / $\overline{\text{BREQO}}$	PF2 (I/O) / $\overline{\text{LCAS}}$ (output) / $\overline{\text{WAIT}}$ (input) / $\overline{\text{BREQO}}$ (output)
PF1/ $\overline{\text{BACK}}$ / $\overline{\text{BUZZ}}$	PF1 (I/O) / $\overline{\text{BACK}}$ (output) / $\overline{\text{BUZZ}}$ (output)
PF0/ $\overline{\text{BREQ}}$ / $\overline{\text{IRQ2}}$	PF0 (I/O) / $\overline{\text{BREQ}}$ (input) / $\overline{\text{IRQ2}}$ (input)
<b>Pin functions in mode 7</b>	
	PF7 (input) / $\emptyset$ (output)
	PF6 (I/O)
	PF5 (I/O)
	PF4 (I/O)
	PF3 (I/O) / $\overline{\text{ADTRG}}$ (input) / $\overline{\text{IRQ3}}$ (input)
	PF2 (I/O)
	PF1 (I/O) / $\overline{\text{BUZZ}}$ (output)
	PF0 (I/O) / $\overline{\text{IRQ2}}$ (input)

Figure 10A-22 Port F Pin Functions



### 10A.12.2 Register Configuration

Table 10A-20 shows the port F register configuration.

**Table 10A-20 Port F Registers**

Name	Abbreviation	R/W	Initial Value	Address*1
Port F data direction register	PFDDR	W	H'80/H'00*2	H'FE3E
Port F data register	PFDR	R/W	H'00	H'FF0E
Port F register	PORTF	R	Undefined	H'FFBE

Notes: \*1 Lower 16 bits of the address.

\*2 Initial value depends on the mode.

#### Port F Data Direction Register (PFDDR)

Bit	:	7	6	5	4	3	2	1	0
		PF7DDR	PF6DDR	PF5DDR	PF4DDR	PF3DDR	PF2DDR	PF1DDR	PF0DDR
Modes 4 to 6									
Initial value :		1	0	0	0	0	0	0	0
R/W :		W	W	W	W	W	W	W	W
Mode 7									
Initial value :		0	0	0	0	0	0	0	0
R/W :		W	W	W	W	W	W	W	W

PFDDR is an 8-bit write-only register, the individual bits of which specify input or output for the pins of port F. PFDDR cannot be read; if it is, an undefined value will be read.

PFDDR is initialized by a power-on reset, and in hardware standby mode, to H'80 in modes 4 to 6, and to H'00 in mode 7. It retains its prior state by a manual reset or in software standby mode. The OPE bit in SBYCR is used to select whether the bus control output pins retain their output state or become high-impedance when a transition is made to software standby mode.

- Modes 4 to 6

Pin PF7 functions as the  $\emptyset$  output pin when the corresponding PFDDR bit is set to 1, and as an input port when the bit is cleared to 0.

The input/output direction specified by PFDDR is ignored for pins PF6 to PF3, which are automatically designated as bus control outputs ( $\overline{AS}$ ,  $\overline{RD}$ ,  $\overline{HWR}$ , and  $\overline{LWR}$ ). PF6 functions as a bus control output ( $\overline{LCAS}$ ) by setting of the bus controller.

Pins PF2 to PF0 are designated as bus control input/output pins ( $\overline{\text{LCAS}}$ ,  $\overline{\text{WAIT}}$ ,  $\overline{\text{BREQ0}}$ ,  $\overline{\text{BACK}}$ , and  $\overline{\text{BREQ}}$ ) by means of bus controller settings. At other times, setting a PFDDR bit to 1 makes the corresponding port F pin an output port, while clearing the bit to 0 makes the pin an input port.

- Mode 7

Setting a PFDDR bit to 1 makes the corresponding port F pin PF6 to PF0 an output port, or in the case of pin PF7, the  $\emptyset$  output pin. Clearing the bit to 0 makes the pin an input port.

#### Port F Data Register (PFDR)

Bit	:	7	6	5	4	3	2	1	0
		PF7DR	PF6DR	PF5DR	PF4DR	PF3DR	PF2DR	PF1DR	PF0DR
Initial value :		0	0	0	0	0	0	0	0
R/W	:	R/W	R/W	R/W	R/W	R/W	R/W	R/W	R/W

PFDR is an 8-bit readable/writable register that stores output data for the port F pins (PF7 to PF0).

PFDR is initialized to H'00 by a power-on reset, and in hardware standby mode. It retains its prior state by a manual reset or in software standby mode.

#### Port F Register (PORTF)

Bit	:	7	6	5	4	3	2	1	0
		PF7	PF6	PF5	PF4	PF3	PF2	PF1	PF0
Initial value :		—*	—*	—*	—*	—*	—*	—*	—*
R/W	:	R	R	R	R	R	R	R	R

Note: \* Determined by state of pins PF7 to PF0.

PORTF is an 8-bit read-only register that shows the pin states. It cannot be written to. Writing of output data for the port F pins (PF7 to PF0) must always be performed on PFDR.

If a port F read is performed while PFDDR bits are set to 1, the PFDR values are read. If a port F read is performed while PFDDR bits are cleared to 0, the pin states are read.

After a power-on reset and in hardware standby mode, PORTF contents are determined by the pin states, as PFDDR and PFDR are initialized. PORTF retains its prior state by a manual reset or in software standby mode.

### 10A.12.3 Pin Functions

Port F pins also function as external interrupt input pins ( $\overline{\text{IRQ2}}$  and  $\overline{\text{IRQ3}}$ ), BUZZ output pin, A/D trigger input pin ( $\overline{\text{ADTRG}}$ ), bus control signal input/output pins ( $\overline{\text{AS}}$ ,  $\overline{\text{RD}}$ ,  $\overline{\text{HWR}}$ ,  $\overline{\text{LWR}}$ ,  $\overline{\text{LCAS}}$ ,  $\overline{\text{WAIT}}$ ,  $\overline{\text{BREQO}}$ ,  $\overline{\text{BREQ}}$ , and  $\overline{\text{BACK}}$ ) and the system clock ( $\emptyset$ ) output pin. The pin functions differ between modes 4 to 6, and mode 7. Port F pin functions are shown in table 10A-21.

**Table 10A-21 Port F Pin Functions**

Pin	Selection Method and Pin Functions			
PF7/ $\emptyset$	The pin function is switched as shown below according to bit PF7DDR.			
	PF7DDR	0		1
	Pin function	PF7 input pin		$\emptyset$ output pin
PF6/ $\overline{\text{AS}}$ / $\overline{\text{LCAS}}$	The pin function is switched as shown below according to the combination of the operating mode and bits RMTS2 to RMTS0, LCASS, BREQOE, WAITE, ABW5 to ABW2, and PF2DDR.			
	Operating Mode	Modes 4 to 6		Mode 7
	LCASS	0	1*	—
	PF6DDR	—	—	0      1
	Pin function	$\overline{\text{AS}}$ output pin	$\overline{\text{LCAS}}$ output pin	PF6 input pin
Note: * Restricted to RMTS2 to RMTS0=B'001 to B'011, DRAM space 16-bit access in modes 4 to 6 only				
PF5/ $\overline{\text{RD}}$	The pin function is switched as shown below according to the operating mode and bit PF5DDR.			
	Operating Mode	Modes 4 to 6	Mode 7	
	PF5DDR	—	0	1
	Pin function	$\overline{\text{RD}}$ output pin	PF5 input pin	PF5 output pin
PF4/ $\overline{\text{HWR}}$	The pin function is switched as shown below according to the operating mode and bit PF4DDR.			
	Operating Mode	Modes 4 to 6	Mode 7	
	PF4DDR	—	0	1
	Pin function	$\overline{\text{HWR}}$ output pin	PF4 input pin	PF4 output pin

**Pin Selection Method and Pin Functions**

**PF3/LWR/ADTRG/IRQ3** The pin function is switched as shown below according to the operating mode, the bus mode, A/D converter bits TRGS1 and TRGS0, and bit PF3DDR.

Operating mode	Modes 4 to 6			Mode 7	
Bus mode	16-bit bus mode	8-bit bus mode		—	
PF3DDR	—	0	1	0	1
Pin function	LWR output pin	PF3 input pin	PF3 output pin	PF3 input pin	PF3 output pin
		ADTRG input pin* <sup>1</sup>			
		IRQ3 input pin* <sup>2</sup>			

Notes: \*1 ADTRG input when TRGS0 = TRGS1 = 1.

\*2 When used as an external interrupt input pin, do not use as an I/O pin for another function.

**PF2/LCAS/WAIT/BREQO** The pin function is switched as shown below according to the combination of the operating mode and bits RMTS2 to RMTS0, LCASS, BREQOE, WAITE, ABW5 to ABW2, and PF2DDR.

Operating Mode	Modes 4 to 6					Mode 7	
LCASS	0*	1			—		
BREQOE	—	0		1	—		
WAITE	—	0		1	—	—	
PF2DDR	—	0	1	—	—	0	1
Pin function	LCAS output pin	PF2 input pin	PF2 output pin	WAIT input pin	BREQO output pin	PF2 input pin	PF2 output pin

Note: \* Restricted to RMTS2 to RMTS0=B'001 to B'011, DRAM space 16-bit access in modes 4 to 6 only.

**PF1/BACK/BUZZ** The pin function is switched as shown below according to the combination of the operating mode and bits BRLE, BUZZE, and PF1DDR.

Operating Mode	Modes 4 to 6				Mode 7		
BRLE	0		1		—		
BUZZE	0		1	—	0		1
PF1DDR	0	1	—	—	0	1	—
Pin function	PF1 input pin	PF1 output pin	BUZZ output pin	BACK output pin	PF1 input pin	PF1 output pin	BUZZ output pin

**Pin Selection Method and Pin Functions**

PF0/ $\overline{\text{BREQ}}$ / $\overline{\text{IRQ2}}$  The pin function is switched as shown below according to the combination of the operating mode, and bits BRLE and PF0DDR.

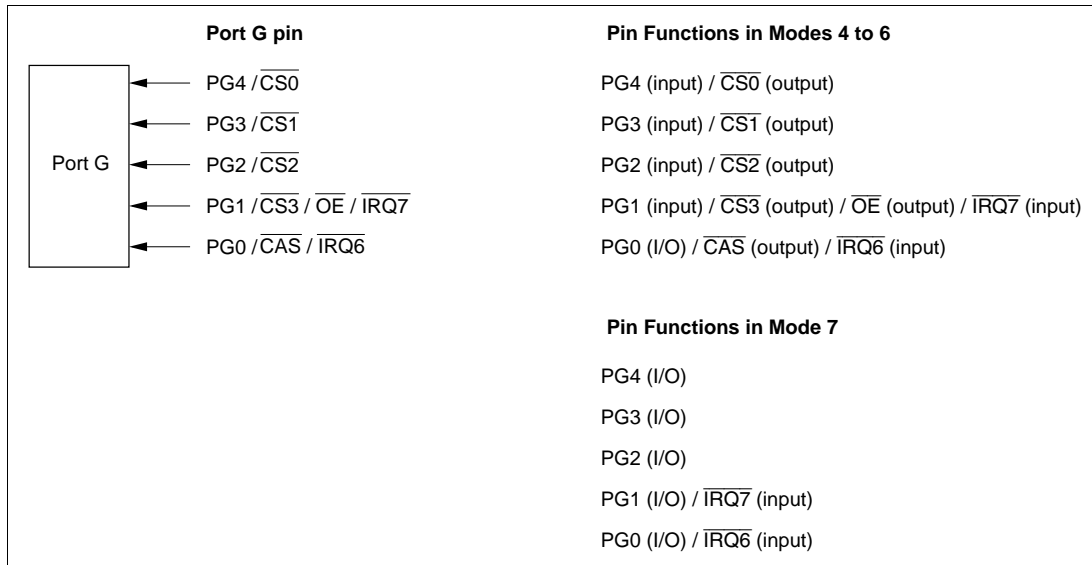
Operating Mode	Modes 4 to 6			Mode 7	
	0		1	—	
BRLE	0		1	—	
PF0DDR	0	1	—	0	1
Pin function	PF0 input pin	PF0 output pin	$\overline{\text{BREQ}}$ input pin	PF0 input pin	PF0 output pin
	$\overline{\text{IRQ2}}$ input pin				

**10A.13 Port G**

**10A.13.1 Overview**

Port G is a 5-bit I/O port and also used as external interrupt input pins ( $\overline{\text{IRQ6}}$  and  $\overline{\text{IRQ7}}$ ) and bus control signal output pins ( $\overline{\text{CS0}}$  to  $\overline{\text{CS3}}$ ,  $\overline{\text{CAS}}$ , and  $\overline{\text{OE}}$ ).

Figure 10A-23 shows the configuration of port G pins.



**Figure 10A-23 Port G Pin Functions**

### 10A.13.2 Register Configuration

Table 10A-22 shows the port G register configuration.

**Table 10A-22 Port G Registers**

Name	Abbreviation	R/W	Initial Value* <sup>2</sup>	Address* <sup>1</sup>
Port G data direction register	PGDDR	W	H'10/H'00* <sup>3</sup>	H'FE3F
Port G data register	PGDR	R/W	H'00	H'FF0F
Port G register	PORTG	R	Undefined	H'FFBF

Notes: \*1 Lower 16 bits of the address.

\*2 Value of bits 4 to 0.

\*3 The initial value varies according to the mode.

#### Port G Data Direction Register (PGDDR)

Bit	:	7	6	5	4	3	2	1	0
		—	—	—	PG4DDR	PG3DDR	PG2DDR	PG1DDR	PG0DDR
Modes 4 and 5									
Initial value	:	Undefined	Undefined	Undefined	1	0	0	0	0
R/W	:	—	—	—	W	W	W	W	W
Modes 6 and 7									
Initial value	:	Undefined	Undefined	Undefined	0	0	0	0	0
R/W	:	—	—	—	W	W	W	W	W

PGDDR is an 8-bit write only register and specifies I/O of each pin of port G in bit units. Read processing is invalid. Bits 7 to 5 are reserved bits. When the contents are read, undefined values are read.

In modes 4 and 5, the PG4DDR bits are initialized to H'10 (bits 4 to 0) in power-on reset or hardware standby mode, in modes 6 and 7, the bits are initialized to H'00 (bits 4 to 0). In manual reset or software standby mode, PGDDR retains the last status. Use the OPE bit of SBYCR to select whether the bus control output pin retains the output state or becomes the high-impedance when the mode is changed to a software standby mode.

- Modes 4 to 6

When PGDDR is set to 1, pins PG4 to PG1 function as bus control signal output pins ( $\overline{CS0}$  to  $\overline{CS3}$  and  $\overline{OE}$ ). When PGDDR is cleared to 0, the pins function as input ports.

When the DRAM interface is set, pin PG0 functions as the  $\overline{CAS}$  output pin. When PGDDR is set to 1, the pin functions as an output port. When PGDDR is cleared to 0, the pin functions as an input port.

See section 7, Bus Controller, for the DRAM interface.

- Mode 7

PGDDR to 1 it becomes an output port, and by clearing it to 0 it becomes an input port.

**Port G Data Register (PGDR)**

Bit	:	7	6	5	4	3	2	1	0
		—	—	—	PG4DR	PG3DR	PG2DR	PG1DR	PG0DR
Initial value	:	Undefined	Undefined	Undefined	0	0	0	0	0
R/W	:	—	—	—	R/W	R/W	R/W	R/W	R/W

PGDR is an 8-bit read/write register and stores output data of port G output pins (PG4 to PG0).

Bits 7 to 5 are reserved bits. When the contents are read, undefined values are read. Write processing is invalid.

In power-on reset or hardware standby mode, PGDR is initialized to H'00 (bits 4 to 0). In manual reset or software standby mode, PGDR retains the last state.

**(3) Port G Register (PORTG)**

Bit	:	7	6	5	4	3	2	1	0
		—	—	—	PG4	PG3	PG2	PG1	PG0
Initial value	:	Undefined	Undefined	Undefined	—*	—*	—*	—*	—*
R/W	:	—	—	—	R	R	R	R	R

Note: \* Determined by the state of PG4 to PG0

PORTG is an 8-bit read only register and reflects the pin state. Write processing is invalid. Write processing of output data of port G pins (PG4 to PG0) must be performed for PGDR.

Bits 7 to 5 are reserved bits. When the contents are read, undefined values are read. Write processing is invalid.

If port G is read when PGDDR is set to 1, the value in PGDR is read. If port G is read when PGDDR is cleared to 0, the pin state is read.

In power-on reset or hardware standby mode, port G is determined by the pin state because PGDDR and PGDR are initialized. In manual reset or software standby mode, the last state is retained.

### 10A.13.3 Pin Functions

Port G is used also as external interrupt input pins ( $\overline{\text{IRQ6}}$  and  $\overline{\text{IRQ7}}$ ) and bus control signal output pins ( $\overline{\text{CS0}}$  to  $\overline{\text{CS3}}$ ,  $\overline{\text{CAS}}$ , and  $\overline{\text{OE}}$ ). The pin functions are different between modes 4 and 6, and mode 7. Table 10A-23 shows the port G pin functions.

**Table 10A-23 Port G Pin Functions**

Pin	Selection Method and Pin Functions				
PG4/ $\overline{\text{CS0}}$	The pin function is switched as shown below according to the operating mode and bit PG4DDR.				
	Operating Mode	Modes 4 to 6		Mode 7	
	PG4DDR	0	1	0	1
	Pin function	PG4 input pin	$\overline{\text{CS0}}$ output pin	PG4 input pin	PG4 output pin
PG3/ $\overline{\text{CS1}}$	The pin function is switched as shown below according to the operating mode and bit PG3DDR.				
	Operating Mode	Modes 4 to 6		Mode 7	
	PG3DDR	0	1	0	1
	Pin function	PG3 input pin	$\overline{\text{CS1}}$ output pin	PG3 input pin	PG3 output pin
PG2/ $\overline{\text{CS2}}$	The pin function is switched as shown below according to the operating mode and bit PG2DDR.				
	Operating Mode	Modes 4 to 6		Mode 7	
	PG2DDR	0	1	0	1
	Pin function	PG2 input pin	$\overline{\text{CS2}}$ output pin	PG2 input pin	PG2 output pin



**Pin Selection Method and Pin Functions**

**PG1/ $\overline{\text{CS3}}$ / $\overline{\text{OE}}$ /IRQ7** The pin function is switched as shown below according to the operating mode and bits OES and PG1DDR in BCRL.

Operating Mode	Modes 4 to 6			Mode 7	
PG1DDR	0	1		0	1
OES	—	0	1	—	—
Pin function	PG1 input pin	$\overline{\text{CS3}}$ output pin	$\overline{\text{OE}}$ output pin	PG1 input pin	PG1 output pin
	$\overline{\text{IRQ7}}$ input				

**PG0/ $\overline{\text{CAS}}$ / $\overline{\text{IRQ6}}$**  The pin function is switched as shown below according to the operating mode and bits RMTS2 to RMTS0 in BCRH.

Operating Mode	Modes 4 to 6			Mode 7	
RMTS2 to RMTS0	B'000		B'001 to B'011	—	
PG0DDR	0	1	—	0	1
Pin function	PG0 input pin	PG0 output pin	$\overline{\text{CAS}}$ output pin	PG0 input pin	PG0 output pin
	$\overline{\text{IRQ6}}$ input				



## Section 10B I/O Ports (H8S/2695)

### 10B.1 Overview

The H8S/2633 Series has 10 I/O ports (ports 1, 3, 7 and A to G), and two input-only port (ports 4 and 9).

Table 10B-1 summarizes the port functions. The pins of each port also have other functions.

Each I/O port includes a data direction register (DDR) that controls input/output, a data register (DR) that stores output data, and a port register (PORT) used to read the pin states. The input-only ports do not have a DR or DDR register.

Ports A to E have a built-in pull-up MOS function, and in addition to DR and DDR, have a MOS input pull-up control register (PCR) to control the on/off state of MOS input pull-up.

Ports 3, and A to C include an open-drain control register (ODR) that controls the on/off state of the output buffer PMOS.

When ports 10 to 13, 70 to 73, and A to G are used as the output pins for expanded bus control signals, they can drive one TTL load plus a 50pF capacitance load. Those ports in other cases, and ports 14 to 17, 3, and 74 to 77, can drive one TTL load and a 30pF capacitance load. All I/O ports can drive Darlington transistors when set to output.

See Appendix C, I/O Port Block Diagrams, for a block diagram of each port.

**Table 10B-1 Port Functions**

Port	Description	Pins	Mode 4	Mode 5	Mode 6	Mode 7
Port 1	<ul style="list-style-type: none"> <li>8-bit I/O port</li> <li>Schmitt-triggered input (P16, P14)</li> </ul>	P17/TIOCB2/TCLKD P16/TIOCA2// $\overline{\text{IRQ1}}$ P15/TIOCB1/TCLKC P14/TIOCA1// $\overline{\text{IRQ0}}$ P13/TIOCD0/TCLKB/A23 P12/TIOCC0/TCLKA/A22 P11/TIOCB0/A21 P10/TIOCA0/A20	8-bit I/O port also functioning as TPU I/O pins (TCLKA, TCLKB, TCLKC, TCLKD, TIOCA0, TIOCB0, TIOCC0, TIOCD0, TIOCA1, TIOCB1, TIOCA2, TIOCB2), interrupt input pins ( $\overline{\text{IRQ0}}$ , $\overline{\text{IRQ1}}$ ), and address outputs (A20 to A23)			8-bit I/O port also functioning as TPU I/O pins (TCLKA, TCLKB, TCLKC, TCLKD, TIOCA0, TIOCB0, TIOCC0, TIOCD0, TIOCA1, TIOCB1, TIOCA2, TIOCB2) and interrupt input pins ( $\overline{\text{IRQ0}}$ , $\overline{\text{IRQ1}}$ )
Port 3	<ul style="list-style-type: none"> <li>8-bit I/O port</li> <li>Open-drain output capability</li> <li>Schmitt-triggered input (P35, P32)</li> </ul>	P37/TxD4 P36/RxD4 P35/SCK1/SCK4// $\overline{\text{IRQ5}}$ P34 /RxD1 P33 /TxD1 P32 /SCK0// $\overline{\text{IRQ4}}$ P31 /RxD0 P30 /TxD0	8-bit I/O port also functioning as SCI (channel 0, 1, and 4) I/O pins (TxD0, RxD0, SCK0, TxD1, RxD1, SCK1, TxD4, RxD4, SCK4) and interrupt input pins ( $\overline{\text{IRQ4}}$ , $\overline{\text{IRQ5}}$ )			
Port 4	<ul style="list-style-type: none"> <li>8-bit input port</li> </ul>	P47 /AN7 P46 /AN6 P45 /AN5 P44 /AN4 P43 /AN3 P42 /AN2 P41 /AN1 P40/AN0	8-bit input port also functioning as A/D converter analog inputs (AN7 to AN0)			
Port 7	<ul style="list-style-type: none"> <li>8-bit I/O port</li> </ul>	P77/TxD3 P76/RxD3 P75/SCK3 P74// $\overline{\text{MRES}}$ P73// $\overline{\text{CS7}}$ P72// $\overline{\text{CS6}}$ P71// $\overline{\text{CS5}}$ P70// $\overline{\text{CS4}}$	8-bit I/O port also functioning as bus control output pins ( $\overline{\text{CS4}}$ to $\overline{\text{CS7}}$ ), SCI I/O pins (SCK3, RxD3, TxD3), and the manual reset input pin ( $\overline{\text{MRES}}$ )			8-bit I/O port also functioning as SCI I/O pins (SCK3, RxD3, TxD3) and the manual reset input pin ( $\overline{\text{MRES}}$ )

Port	Description	Pins	Mode 4	Mode 5	Mode 6	Mode 7
Port 9	<ul style="list-style-type: none"> <li>• 8-bit input port</li> </ul>	P97/AN15 P96/AN14 P95/AN13 P94/AN12 P93/AN11 P92/AN10 P91/AN9 P90/AN8	8-bit input port also functioning as A/D converter analog inputs (AN15 to AN8)			
Port A	<ul style="list-style-type: none"> <li>• 4-bit I/O port</li> <li>• Built-in MOS input pull-up</li> <li>• Open-drain output capability</li> </ul>	PA3/A19/SCK2 PA2/A18/RxD2 PA1/A17/TxD2 PA0/A16	4-bit I/O port also functioning as SCI (channel 2) I/O pins (TxD2, RxD2, SCK2) and address outputs (A19 to A16)		4-bit I/O port also functioning as SCI (channel 2) I/O pins (TxD2, RxD2, SCK2)	
Port B	<ul style="list-style-type: none"> <li>• 8-bit I/O port</li> <li>• Built-in MOS input pull-up</li> <li>• Open-drain output capability</li> </ul>	PB7/A15/TIOCB5 PB6/A14/TIOCA5 PB5/A13/TIOCB4 PB4/A12/TIOCA4 PB3/A11/TIOCD3 PB2/A10/TIOCC3 PB1/A9/TIOCB3 PB0/A8/TIOCA3	8-bit I/O port also functioning as TPU I/O pins (TIOCB5, TIOCA5, TIOCB4, TIOCA4, TIOCD3, TIOCC3, TIOCB3, TIOCA3) and address outputs (A15 to A8)		8-bit I/O port also functioning as TPU I/O pins (TIOCB5, TIOCA5, TIOCB4, TIOCA4, TIOCD3, TIOCC3, TIOCB3, TIOCA3)	
Port C	<ul style="list-style-type: none"> <li>• 8-bit I/O port</li> <li>• Built-in MOS input pull-up</li> <li>• Open-drain output capability</li> </ul>	PC7/A7 PC6/A6 PC5/A5 PC4/A4 PC3/A3 PC2/A2 PC1/A1 PC0 /A0	8-bit I/O port also functioning as address outputs (A7 to A0)		8-bit I/O port also functioning	

Port	Description	Pins	Mode 4	Mode 5	Mode 6	Mode 7
Port D	<ul style="list-style-type: none"> <li>8-bit I/O port</li> <li>Built-in MOS input pull-up</li> </ul>	PD7 /D15 PD6/D14 PD5/D13 PD4/D12 PD3/D11 PD2/D10 PD1/D9 PD0 /D8	Data bus input/output			I/O port
Port E	<ul style="list-style-type: none"> <li>8-bit I/O port</li> <li>Built-in MOS input pull-up</li> </ul>	PE7/D7 PE6/D6 PE5/D5 PE4/D4 PE3/D3 PE2/D2 PE1/D1 PE0 /D0	In 8-bit-bus mode: I/O port In 16-bit-bus mode: data bus input/output			I/O port
Port F	8-bit I/O port	PF7 / $\emptyset$	When DDR = 0: input port When DDR = 1 (after reset): $\emptyset$ output			When DDR = 0 (after reset): input port When DDR = 1: $\emptyset$ output
		PF6/ $\overline{AS}$ PF5/ $\overline{RD}$ PF4/ $\overline{HWR}$ PF3/ $\overline{LWR}/\overline{ADTRG}/\overline{IRQ3}$	$\overline{RD}$ , $\overline{HWR}$ , $\overline{LWR}$ outputs $\overline{ADTRG}$ , $\overline{IRQ3}$ input			I/O port $\overline{ADTRG}$ , $\overline{IRQ3}$ input
		PF2/ $\overline{WAIT}/\overline{BREQO}$	When WAITE = 0 and BREQOE = 0 (after reset): I/O port When WAITE = 1 and BREQOE = 0: $\overline{WAIT}$ input When WAITE = 0 and BREQOE = 1: $\overline{BREQO}$ input			I/O port
		PF1/ $\overline{BACK}$ PF0/ $\overline{BREQ}/\overline{IRQ2}$	When BRLE = 0 (after reset): I/O port When BRLE = 1: $\overline{BREQ}$ input, $\overline{BACK}$ output $\overline{IRQ2}$ input			$\overline{IRQ2}$ input I/O port

Port	Description	Pins	Mode 4	Mode 5	Mode 6	Mode 7
Port G	• 5-bit I/O port	PG4/ $\overline{CS0}$	When DDR = 0* <sup>1</sup> : input port When DDR = 1* <sup>2</sup> : $\overline{CS0}$ output			I/O port
		PG3/ $\overline{CS1}$ PG2/ $\overline{CS2}$ PG1/ $\overline{CS3}/\overline{IRQ7}$	When DDR = 0 (after reset): input port When DDR = 1: $\overline{CS1}$ , $\overline{CS2}$ , $\overline{CS3}$ outputs $\overline{IRQ7}$ input			I/O port, $\overline{IRQ7}$ input
		PG0/ $\overline{IRQ6}$	After reset: I/O port $\overline{IRQ6}$ input			I/O port, $\overline{IRQ6}$ input

Notes: \*1 After a reset in mode 6

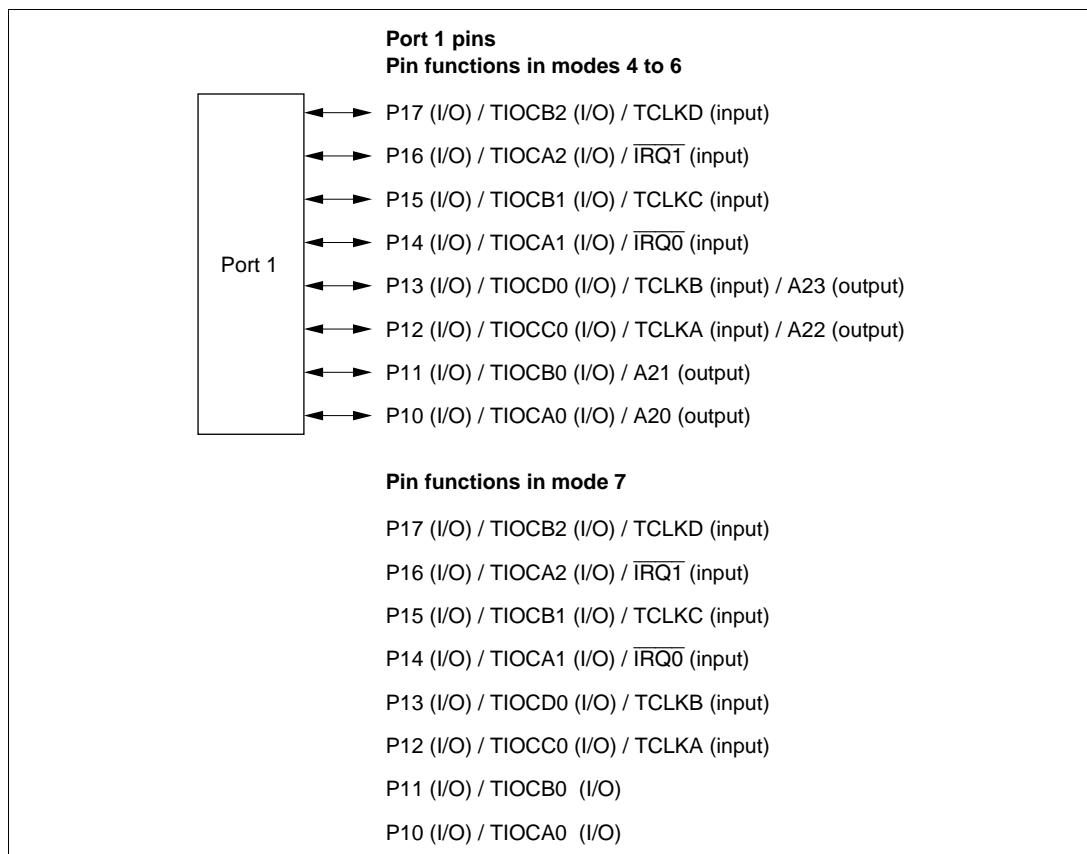
\*2 After a reset in modes 4 or 5

## 10B.2 Port 1

### 10B.2.1 Overview

Port 1 is an 8-bit I/O port. Port 1 pins also function as TPU I/O pins (TCLKA, TCLKB, TCLKC, TCLKD, TIOCA0, TIOCB0, TIOCC0, TIOCD0, TIOCA1, TIOCB1, TIOCA2, and TIOCB2), external interrupt pins ( $\overline{\text{IRQ0}}$  and  $\overline{\text{IRQ1}}$ ), and address bus output pins (A23 to A20). Port 1 pin functions change according to the operating mode.

Figure 10B-1 shows the port 1 pin configuration.



**Figure 10B-1 Port 1 Pin Functions**



## 10B.2.2 Register Configuration

Table 10B-2 shows the port 1 register configuration.

**Table 10B-2 Port 1 Registers**

Name	Abbreviation	R/W	Initial Value	Address*
Port 1 data direction register	P1DDR	W	H'00	H'FE30
Port 1 data register	P1DR	R/W	H'00	H'FF00
Port 1 register	PORT1	R	Undefined	H'FFB0

Note: \* Lower 16 bits of the address.

### Port 1 Data Direction Register (P1DDR)

Bit	:	7	6	5	4	3	2	1	0
		P17DDR	P16DDR	P15DDR	P14DDR	P13DDR	P12DDR	P11DDR	P10DDR
Initial value :		0	0	0	0	0	0	0	0
R/W	:	W	W	W	W	W	W	W	W

P1DDR is an 8-bit write-only register, the individual bits of which specify input or output for the pins of port 1. P1DDR cannot be read; if it is, an undefined value will be read.

Setting a P1DDR bit to 1 makes the corresponding port 1 pin an output pin, while clearing the bit to 0 makes the pin an input pin.

P1DDR is initialized to H'00 by a power-on reset, and in hardware standby mode. It retains its prior state by a manual reset or in software standby mode. Because TPU is initialized at a manual reset, pin states are determined by P1DDR and P1DR.

### Port 1 Data Register (P1DR)

Bit	:	7	6	5	4	3	2	1	0
		P17DR	P16DR	P15DR	P14DR	P13DR	P12DR	P11DR	P10DR
Initial value :		0	0	0	0	0	0	0	0
R/W	:	R/W	R/W	R/W	R/W	R/W	R/W	R/W	R/W

P1DR is an 8-bit readable/writable register that stores output data for the port 1 pins (P17 to P10).

P1DR is initialized to H'00 by a power-on reset, and in hardware standby mode. It retains its prior state by a manual reset or in software standby mode.

### Port 1 Register (PORT1)

Bit	:	7	6	5	4	3	2	1	0
		P17	P16	P15	P14	P13	P12	P11	P10
Initial value :		—*	—*	—*	—*	—*	—*	—*	—*
R/W	:	R	R	R	R	R	R	R	R

Note: \* Determined by state of pins P17 to P10.

PORT1 is an 8-bit read-only register that shows the pin states. It cannot be written to. Writing of output data for the port 1 pins (P17 to P10) must always be performed on P1DR.

If a port 1 read is performed while P1DDR bits are set to 1, the P1DR values are read. If a port 1 read is performed while P1DDR bits are cleared to 0, the pin states are read.

After a power-on reset and in hardware standby mode, PORT1 contents are determined by the pin states, as P1DDR and P1DR are initialized. PORT1 retains its prior state by a manual reset or in software standby mode.

### 10B.2.3 Pin Functions

Port 1 pins also function as TPU I/O pins (TCLKA, TCLKB, TCLKC, TCLKD, TIOCA0, TIOCB0, TIOCC0, TIOCD0, TIOCA1, TIOCB1, TIOCA2, and TIOCB2), external interrupt input pins ( $\overline{\text{IRQ0}}$  and  $\overline{\text{IRQ1}}$ ), and address bus output pins (A23 to A20). Port 1 pin functions are shown in table 10B-3.

**Table 10B-3 Port 1 Pin Functions**

Pin	Selection Method and Pin Functions						
P17/TIOCB2/ TCLKD	The pin function is switched as shown below according to the combination of the TPU channel 2 setting (by bits MD3 to MD0 in TMDR2, bits IOB3 to IOB0 in TIOR2, and bits CCLR1 and CCLR0 in TCR2), bits TPSC2 to TPSC0 in TCR0 and TCR5, and bit P17DDR.						
	TPU Channel 2 Setting	Table Below (1)		Table Below (2)			
	P17DDR	—		0	1		
	Pin function	TIOCB2 output		P17 input	P17 output		
				TIOCB2 input*1			
		TCLKD input*2					
Notes: *1 TIOCB2 input when MD3 to MD0 = B'0000 or B'01xx, and IOB3 = 1.							
*2 TCLKD input when the setting for either TCR0 or TCR5 is: TPSC2 to TPSC0 = B'111. TCLKD input when channels 2 and 4 are set to phase counting mode.							
	TPU Channel 2 Setting	(2)	(1)	(2)	(2)	(1)	(2)
	MD3 to MD0	B'0000, B'01xx		B'0010	B'0011		
	IOB3 to IOB0	B'0000 B'0100 B'1xxx	B'0001 to B'0011 B'0101 to B'0111	—	B'xx00	Other than B'xx00	
	CCLR1, CCLR0	—	—	—	—	Other than B'10	B'10
	Output function	—	Output compare output	—	—	PWM mode 2 output	—

x: Don't care

**Pin Selection Method and Pin Functions**

P16/TIOCA2/  
IRQ1

The pin function is switched as shown below according to the combination of the TPU channel 2 setting (by bits MD3 to MD0 in TMDR2, bits IOA3 to IOA0 in TIOR2, and bits CCLR1 and CCLR0 in TCR2), and bit P16DDR.

TPU Channel 2 Setting	Table Below (1)	Table Below (2)	
P16DDR	—	0	1
Pin function	TIOCA2 output	P16 input	P16 output
		TIOCA2 input*1	
	IRQ1 input		

TPU Channel 2 Setting	(2)	(1)	(2)	(1)	(1)	(2)
MD3 to MD0	B'0000, B'01xx		B'001x	B'0010	B'0011	
IOA3 to IOA0	B'0000 B'0100 B'1xxx	B'0001 to B'0011 B'0101 to B'0111	B'xx00	Other than B'xx00		
CCLR1, CCLR0	—	—	—	—	Other than B'01	B'01
Output function	—	Output compare output	—	PWM mode 1 output*2	PWM mode 2 output	—

x: Don't care

Notes: \*1 TIOCA2 input when MD3 to MD0 = B'0000 or B'01xx, and IOA3 = 1.

\*2 TIOCB2 output is disabled.

**Pin**

**Selection Method and Pin Functions**

P15/TIOCB1/  
TCLKC

The pin function is switched as shown below according to the combination of the TPU channel 1 setting (by bits MD3 to MD0 in TMDR1, bits IOB3 to IOB0 in TIOR1, and bits CCLR1 and CCLR0 in TCR1), bits TPSC2 to TPSC0 in TCR0, TCR2, TCR4, and TCR5, and bit P15DDR.

TPU Channel 1 Setting	Table Below (1)	Table Below (2)	
P15DDR	—	0	1
Pin function	TIOCB1 output	P15 input	P15 output
		TIOCB1 input*1	
	TCLKC input*2		

Notes: \*1 TIOCB1 input when MD3 to MD0 = B'0000 or B'01xx, and IOB3 to IOB0 = B'10xx.

\*2 TCLKC input when the setting for either TCR0 or TCR2 is: TPSC2 to TPSC0 = B'110; or when the setting for either TCR4 or TCR5 is TPSC2 to TPSC0 = B'101.  
TCLKC input when channels 2 and 4 are set to phase counting mode.

TPU Channel 1 Setting	(2)	(1)	(2)	(2)	(1)	(2)
MD3 to MD0	B'0000, B'01xx		B'0010	B'0011		
IOB3 to IOB0	B'0000 B'0100 B'1xxx	B'0001 to B'0011 B'0101 to B'0111	—	B'xx00	Other than B'xx00	
CCLR1, CCLR0	—	—	—	—	Other than B'10	B'10
Output function	—	Output compare output	—	—	PWM mode 2 output	—

x: Don't care

**Pin Selection Method and Pin Functions**

P14/TIOCA1/  
IRQ0

The pin function is switched as shown below according to the combination of the TPU channel 1 setting (by bits MD3 to MD0 in TMDR1, bits IOA3 to IOA0 in TIOR1, and bits CCLR1 and CCLR0 in TCR1), and bit P14DDR.

TPU Channel 1 Setting	Table Below (1)	Table Below (2)	
P14DDR	—	0	1
Pin function	TIOCA1 output	P14 input	P14 output
		TIOCA1 input*1	
	IRQ0 input		

TPU Channel 1 Setting	(2)	(1)	(2)	(1)	(1)	(2)
MD3 to MD0	B'0000, B'01xx	B'001x	B'0010	B'0011		
IOA3 to IOA0	B'0000 B'0100 B'1xxx	B'0001 to B'0011 B'0101 to B'0111	B'xx00	Other than B'xx00	Other than B'xx00	
CCLR1, CCLR0	—	—	—	—	Other than B'01	B'01
Output function	—	Output compare output	—	PWM mode 1 output*2	PWM mode 2 output	—

x: Don't care

Notes: \*1 TIOCA1 input when MD3 to MD0 = B'0000 or B'01xx, and IOA3 to IOA0 = B'10xx.

\*2 TIOCB1 output is disabled.

**Pin****Selection Method and Pin Functions**P13/TIOCD0/  
TCLKB/A23

The pin function is switched as shown below according to the combination of the operating mode, and the TPU channel 0 setting (by bits MD3 to MD0 in TMDR0, bits IOD3 to IOD0 in TIOR0L, and bits CCLR2 to CCLR0 in TCR0), bits TPSC2 to TPSC0 in TCR0 to TCR2, bits AE3 to AE0 in PFCR, and bit P13DDR.

Operating mode	Modes 4 to 6			
AE3 to AE0	B'0000 to B'1110			B'1111
TPU Channel 0 Setting	Table Below (1)	Table Below (2)		—
P13DDR	—	0	1	—
Pin function	TIOCD0 output	P13 input	P13 output	A23 output
		TIOCD0 input*1		
	TCLKB input*2			

Operating mode	Mode 7		
AE3 to AE0	—		
TPU Channel 0 Setting	Table Below (1)	Table Below (2)	
P13DDR	—	0	1
Pin function	TIOCD0 output	P13 input	P13 output
		TIOCD0 input*1	
	TCLKB input*2		

Notes: \*1 TIOCD0 input when MD3 to MD0 = B'0000, and IOD3 to IOD0 = B'10xx.

\*2 TCLKB input when the setting for TCR0 to TCR2 is: TPSC2 to TPSC0 = B'101.  
TCLKB input when channels 1 and 5 are set to phase counting mode.

**Pin****Selection Method and Pin Functions**

P13/TIOCD0/ TCLKB/A23 (cont)	TPU Channel 0 Setting	(2)	(1)	(2)	(2)	(1)	(2)
	MD3 to MD0	B'0000		B'0010	B'0011		
	IOD3 to IOD0	B'0000 B'0100 B'1xxx	B'0001 to B'0011 B'0101 to B'0111	—	B'xx00	Other than B'xx00	
	CCLR2 to CCLR0	—	—	—	—	Other than B'110	B'110
	Output function	—	Output compare output	—	—	PWM mode 2 output	—

x: Don't care



**Pin****Selection Method and Pin Functions**P12/TIOCC0/  
TCLKA/A22

The pin function is switched as shown below according to the combination of the operating mode, and the TPU channel 0 setting (by bits MD3 to MD0 in TMDR0, bits IOC3 to IOC0 in TIOR0L, and bits CCLR2 to CCLR0 in TCR0), bits TPSC2 to TPSC0 in TCR0 to TCR5, bits AE3 to AE0 in PFCR, and bit P12DDR.

Operating mode	Modes 4 to 6			
AE3 to AE0	B'0000 to B'1110			B'1111
TPU Channel 0 Setting	Table Below (1)	Table Below (2)		—
P12DDR	—	0	1	—
Pin function	TIOCC0 output	P12 input	P12 output	A22 output
		TIOCC0 input* <sup>1</sup>		
	TCLKA input* <sup>2</sup>			

Operating mode	Mode 7		
AE3 to AE0	—		
TPU Channel 0 Setting	Table Below (1)	Table Below (2)	
P12DDR	—	0	1
Pin function	TIOCC0 output	P12 input	P12 output
		TIOCC0 input* <sup>1</sup>	
	TCLKA input* <sup>2</sup>		

**Pin Selection Method and Pin Functions**

P12/TIOCC0/ TCLKA/A22 (cont)	TPU Channel 0 Setting	(2)	(1)	(2)	(1)	(1)	(2)
	MD3 to MD0	B'0000		B'001x	B'0010	B'0011	
	IOC3 to IOC0	B'0000 B'0100 B'1xxx	B'0001 to B'0011 B'0101 to B'0111	B'xx00	Other than B'xx00		
	CCLR2 to CCLR0	—	—	—	—	Other than B'101	B'101
	Output function	—	Output compare output	—	PWM mode 1 output* <sup>3</sup>	PWM mode 2 output	—

x: Don't care

Notes: \*1 TIOCC0 input when MD3 to MD0 = B'0000, and IOC3 to IOC0 = B'10xx.

\*2 TCLKA input when the setting for TCR0 to TCR5 is: TPSC2 to TPSC0 = B'100.

TCLKA input when channels 1 and 5 are set to phase counting mode.

\*3 TIOCD0 output is disabled.

When BFA = 1 or BFB = 1 in TMDR0, output is disabled and setting (2) applies.

**Pin Selection Method and Pin Functions**

P11/TIOCB0/A21 The pin function is switched as shown below according to the combination of the operating mode, and the TPU channel 0 setting (by bits MD3 to MD0 in TMDR0, and bits IOB3 to IOB0 in TIOR0H), bits AE3 to AE0 in PFCR, and bit P11DDR.

Operating mode	Modes 4 to 6			
AE3 to AE0	B'0000 to B'1101		B'1110 to B'1111	
TPU Channel 0 Setting	Table Below (1)	Table Below (2)		—
P11DDR	—	0	1	—
Pin function	TIOCB0 output	P11 input	P11 output	A21 output
		TIOCB0 input*		

Operating mode	Mode 7			
AE3 to AE0	—			
TPU Channel 0 Setting	Table Below (1)	Table Below (2)		
P11DDR	—	0	1	
Pin function	TIOCB0 output	P11 input	P11 output	
		TIOCB0 input*		

Note: \* TIOCB0 input when MD3 to MD0 = B'0000, and IOB3 to IOB0 = B'10xx.

**Pin Selection Method and Pin Functions**

P11/TIOCB0/A21  
(cont)

TPU Channel 0 Setting	(2)	(1)	(2)	(2)	(1)	(2)
MD3 to MD0	B'0000		B'0010	B'0011		
IOB3 to IOB0	B'0000 B'0100 B'1xxx	B'0001 to B'0011 B'0101 to B'0111	—	B'xx00	Other than B'xx00	
CCLR2 to CCLR0	—	—	—	—	Other than B'010	B'010
Output function	—	Output compare output	—	—	PWM mode 2 output	—

x: Don't care

**Pin Selection Method and Pin Functions**

P10/TIOCA0/A20 The pin function is switched as shown below according to the combination of the operating mode, and the TPU channel 0 setting (by bits MD3 to MD0 in TMDR0, bits IOA3 to IOA0 in TIOR0H, and bits CCLR2 to CCLR0 in TCR0), bits AE3 to AE0 in PFCR, and bit P10DDR.

Operating mode	Modes 4 to 6			
AE3 to AE0	B'0000 to B'1110			B'1101 to B'1111
TPU Channel 0 Setting	Table Below (1)	Table Below (2)		—
P10DDR	—	0	1	—
Pin function	TIOCA0 output	P10 input	P10 output	A20 output
		TIOCA0 input*1		

Operating mode	Mode 7			
AE3 to AE0	—			
TPU Channel 0 Setting	Table Below (1)	Table Below (2)		
P10DDR	—	0	1	—
Pin function	TIOCA0 output	P10 input	P10 output	—
		TIOCA0 input*1		

**Pin Selection Method and Pin Functions**

P10/TIOCA0/A20 (cont)	TPU Channel 0 Setting	(2)	(1)	(2)	(1)	(1)	(2)
		MD3 to MD0	B'0000		B'001x	B'0010	B'0011
	IOA3 to IOA0	B'0000 B'0100 B'1xxx	B'0001 to B'0011 B'0101 to B'0111	B'xx00	Other than B'xx00		
	CCLR2 to CCLR0	—	—	—	—	Other than B'001	B'001
	Output function	—	Output compare output	—	PWM mode 1 output*2	PWM mode 2 output	—

x: Don't care

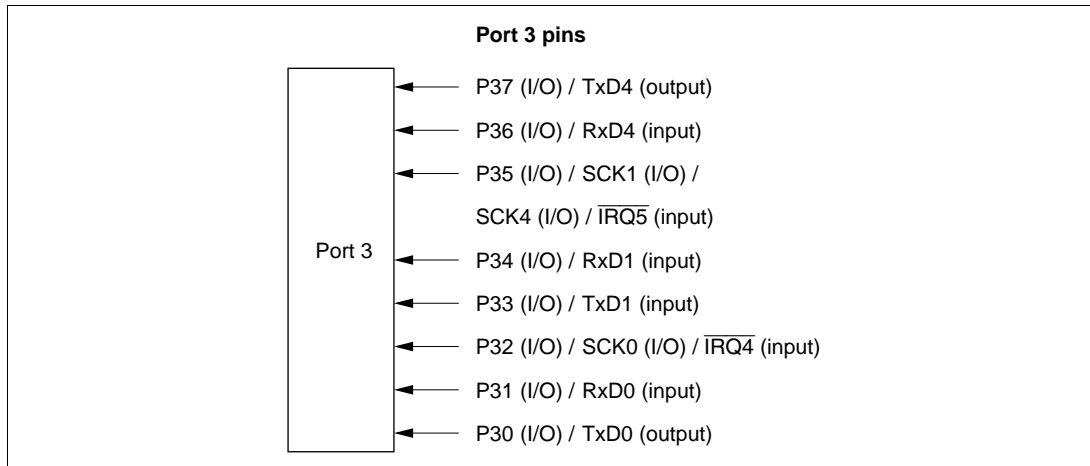
Notes: \*1 TIOCA0 input when MD3 to MD0 = B'0000, and IOA3 to IOA0 = B'10xx.

\*2 TIOCB0 output is disabled.

## 10B.3 Port 3

### 10B.3.1 Overview

Port 3 is an 8-bit I/O port. Port 3 is a multi-purpose port for SCI I/O pins (TxD0, RxD0, SCK0, TxD1, RxD1, SCK1, TxD4, RxD4, and SCK4) and external interrupt input pins ( $\overline{\text{IRQ4}}$  and  $\overline{\text{IRQ5}}$ ). All of the port 3 pin functions have the same operating mode. The configuration for each of the port 3 pins is shown in figure 10B-2.



**Figure 10B-2 Port 3 Pin Functions**

### 10B.3.2 Register Configuration

Table 10B-4 shows the configuration of port 3 registers.

**Table 10B-4 Port 3 Register Configuration**

Name	Abbreviation	R/W	Initial Value	Address*
Port 3 data direction register	P3DDR	W	H'00	H'FE32
Port 3 data register	P3DR	R/W	H'00	H'FF02
Port 3 register	PORT3	R	Undefined	H'FFB2
Port 3 open drain control register	P3ODR	R/W	H'00	H'FE46

Note: \* Lower 16 bits of the address.

### Port 3 Data Direction Register (P3DDR)

Bit	:	7	6	5	4	3	2	1	0
		P37DDR	P36DDR	P35DDR	P34DDR	P33DDR	P32DDR	P31DDR	P30DDR
Initial value	:	0	0	0	0	0	0	0	0
R/W	:	W	W	W	W	W	W	W	W

P3DDR is an 8-bit write-dedicated register, which specifies the I/O for each port 3 pin by bit. Read is disabled. If a read is carried out, undefined values are read out.

By setting P3DDR to 1, the corresponding port 3 pins become output, and by clearing to 0 they become input.

P3DDR is initialized to H'00 by a power-on reset and in hardware standby mode. The previous state is maintained by a manual reset and in software standby mode. SCI is initialized, so the pin state is determined by the specification of P3DDR and P3DR.

### Port 3 Data Register (P3DR)

Bit	:	7	6	5	4	3	2	1	0
		P37DR	P36DR	P35DR	P34DR	P33DR	P32DR	P31DR	P30DR
Initial value	:	0	0	0	0	0	0	0	0
R/W	:	R/W	R/W	R/W	R/W	R/W	R/W	R/W	R/W

P3DR is an 8-bit readable/writable register, which stores the output data of port 3 pins (P35 to P30).

P3DR is initialized to H'00 by a power-on reset and in hardware standby mode. The previous state is maintained by a manual reset and in software standby mode.



### Port 3 Register (PORT3)

Bit	:	7	6	5	4	3	2	1	0
		P37	P36	P35	P34	P33	P32	P31	P30
Initial value	:	—*	—*	—*	—*	—*	—*	—*	—*
R/W	:	R	R	R	R	R	R	R	R

Note: \* Determined by the state of pins P37 to P30.

PORT3 is an 8-bit read-dedicated register, which reflects the state of pins. Write is disabled. Always carry out writing off output data of port 3 pins (P37 to P30) to P3DR without fail.

When P3DDR is set to 1, if port 3 is read, the values of P3DR are read. When P3DDR is cleared to 0, if port 3 is read, the states of pins are read out.

P3DDR and P3DR are initialized by a power-on reset and in hardware standby mode, so PORT3 is determined by the state of the pins. The previous state is maintained by a manual reset and in software standby mode.

### Port 3 Open Drain Control Register (P3ODR)

Bit	:	7	6	5	4	3	2	1	0
		P37ODR	P36ODR	P35ODR	P34ODR	P33ODR	P32ODR	P31ODR	P30ODR
Initial value	:	0	0	0	0	0	0	0	0
R/W	:	R/W	R/W	R/W	R/W	R/W	R/W	R/W	R/W

P3ODR is an 8-bit readable/writable register, which controls the on/off of port 3 pins (P37 to P30).

By setting P3ODR to 1, the port 3 pins become an open drain out, and when cleared to 0 they become CMOS output.

P3ODR is initialized to H'00 by a power-on reset and in hardware standby mode. The previous state is maintained by a manual reset and in software standby mode.

### 10B.3.3 Pin Functions

The port 3 pins double as SCI I/O input pins (TxD0, RxD0, SCK0, TxD1, RxD1, and SCK1). The functions of port 3 pins are shown in table 10B-5.

**Table 10B-5 Port 3 Pin Functions**

Pin	Selection Method and Pin Functions							
P37/TxD4	Switches as follows according to combinations of SCR TE bit of SCI4 and the P37DDR bit.							
	TE	0				1		
	P37DDR	0		1		—		
	Pin function	P37 input pin		P37 output pin*		TxD4 output pin		
Note: * When P37ODR = 1, it becomes NMOS open drain output.								
P36/RxD4	Switches as follows according to combinations of SCR RE bit of SCI4 and the P36DDR bit.							
	RE	0				1		
	P36DDR	0		1		—		
	Pin function	P36 input pin		P36 output pin*		RxD4 input pin		
Note: * When P36ODR = 1, it becomes NMOS open drain output.								
P35/SCK1/ SCK4/IRQ5	Switches as follows according to combinations of the SMR C/ $\bar{A}$ bit of SCI1 or SCI4, the SCR CKE0 and CKE1 bits, and the P35DDR bit.							
	SCK1 and SCK4 should not be set to output simultaneously.							
	CKE1 (SCI1) CKE1 (SCI4)	0 0				0 <sup>*1</sup> 1 <sup>*1</sup>	1 <sup>*1</sup> 0 <sup>*1</sup>	1 1
	C/ $\bar{A}$ (SCI1) C/ $\bar{A}$ (SCI4)	0 0		1 1		—	—	—
	CKE0 (SCI1) CKE0 (SCI4)	0 0	0, 1, 1 <sup>*3</sup> 1, 0, 1 <sup>*3</sup>		—	—	—	—
	P35DDR	0	1	—	—	—	—	0 <sup>*2</sup>
	Pin function	P35 input pin	P35 <sup>*3</sup> output pin	SCK1/SCK4 <sup>*3</sup> output pin	SCK1/SCK4 <sup>*3</sup> output pin	—	—	SCK1/SCK4 input pin
		$\bar{I}RQ5$ input						
	Notes: *1 These settings are prohibited.							
	*2 If SCK1 and SCK4 are used as input (clock input) pins on the H8S/2695, P35DDR must be cleared to 0.							
*3 The output format is CMOS output. It becomes NMOS open drain output if P35ODR is set to 1.								

**Pin Selection Method and Pin Functions**

**P34/RxD1** Switches as follows according to combinations of ICCR0 ICE bit of IIC0, SCR RE bit of SCI1, and the P34DDR bit.

RE	0		1
P34DDR	0	1	—
Pin function	P34 input pin	P34 output pin*	RxD1 input pin

Note: \* Output type is NMOS push-pull. When P34ODR = 1, it becomes NMOS open drain tray.

**P33/TxD1** Switches as follows according to combinations of ICCR1 ICE bit of IIC1, SCR TE bit of SCI1 and the P33DDR bit.

TE	0		1
P33DDR	0	1	—
Pin function	P33 input pin	P33 output pin*	TxD1 output pin*

Note: \* When P33ODR = 1, it becomes NMOS open drain output.

**P32/SCK0/  
IRQ4** Switches as follows according to combinations of SMR C/A bit of SCI0, SCR CKE0 and CKE1 bits, and the P32DDR bit.

If using as an SDA1 input pin, always set SMR C/A bit of SCI0 and SCR CKE0 and CKE1 bits to 0 without fail.

CKE1	0			1
C/A	0		1	—
CKE0	0	1	—	—
P32DDR	0	1	—	—
Pin function	P32 input pin	P32 output pin	SCK0 output pin*	SCK0 output pin*
	IRQ4 input			

Note: \* When P32ODR = 1, it becomes NMOS open drain output.

**Pin Selection Method and Pin Functions**

P31/RxD0 Switches as follows according to combinations of SCR RE bit of SCI0 and the P31DDR bit.

RE	0		1
P31DDR	0	1	—
Pin function	P31 input pin	P31 output pin*	RxD0 input pin

Note: \* When P31ODR = 1, it becomes NMOS open drain output.

P30/TxD0 Switches as follows according to combinations of SCR TE bit of SCI0 and the P30DDR bit.

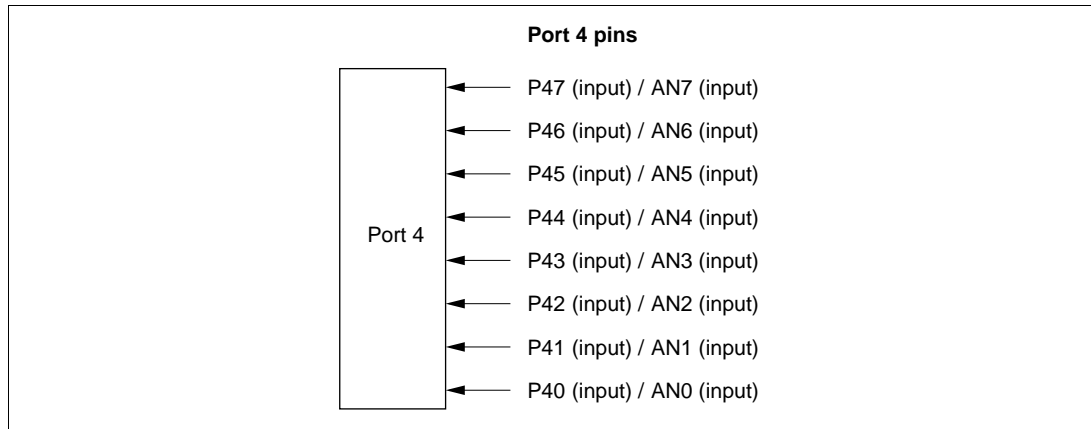
TE	0		1
P30DDR	0	1	—
Pin function	P30 input pin	P30 output pin*	TxD0 output pin*

Note: \* When P30ODR = 1, it becomes NMOS open drain output.

## 10B.4 Port 4

### 10B.4.1 Overview

Port 4 is an 8-bit input-only port. Port 4 pins function as A/D converter analog input pins (AN0 to AN7). Port 4 pin functions are the same in all operating modes. Figure 10B-3 shows the port 4 pin configuration.



**Figure 10B-3 Port 4 Pin Functions**

### 10B.4.2 Register Configuration

Table 10B-6 shows the port 4 register configuration. Port 4 is an input-only port, and does not have a data direction register or data register.

**Table 10B-6 Port 4 Registers**

Name	Abbreviation	R/W	Initial Value	Address*
Port 4 register	PORT4	R	Undefined	H'FFB3

Note: \* Lower 16 bits of the address.

**Port 4 Register (PORT4):** The pin states are always read when a port 4 read is performed.

Bit	:	7	6	5	4	3	2	1	0
		P47	P46	P45	P44	P43	P42	P41	P40
Initial value :		—*	—*	—*	—*	—*	—*	—*	—*
R/W	:	R	R	R	R	R	R	R	R

Note: \* Determined by state of pins P47 to P40.

### 10B.4.3 Pin Functions

Port 4 pins function as A/D converter analog input pins (AN0 to AN7).

## 10B.5 Port 7

### 10B.5.1 Overview

Port 7 is an 8-bit I/O port. Port 7 is a multipurpose port for the bus control output pins ( $\overline{\text{CS4}}$  to  $\overline{\text{CS7}}$ ), SCI I/O pins (SCK3, RxD3, and TxD3), and manual reset input pin ( $\overline{\text{MRES}}$ ). The pin functions for P77 to P74 are the same in all operating modes. P73 to P70 pin functions are switched according to operating mode.

Figure 10B-4 shows the configuration for port 7 pins.

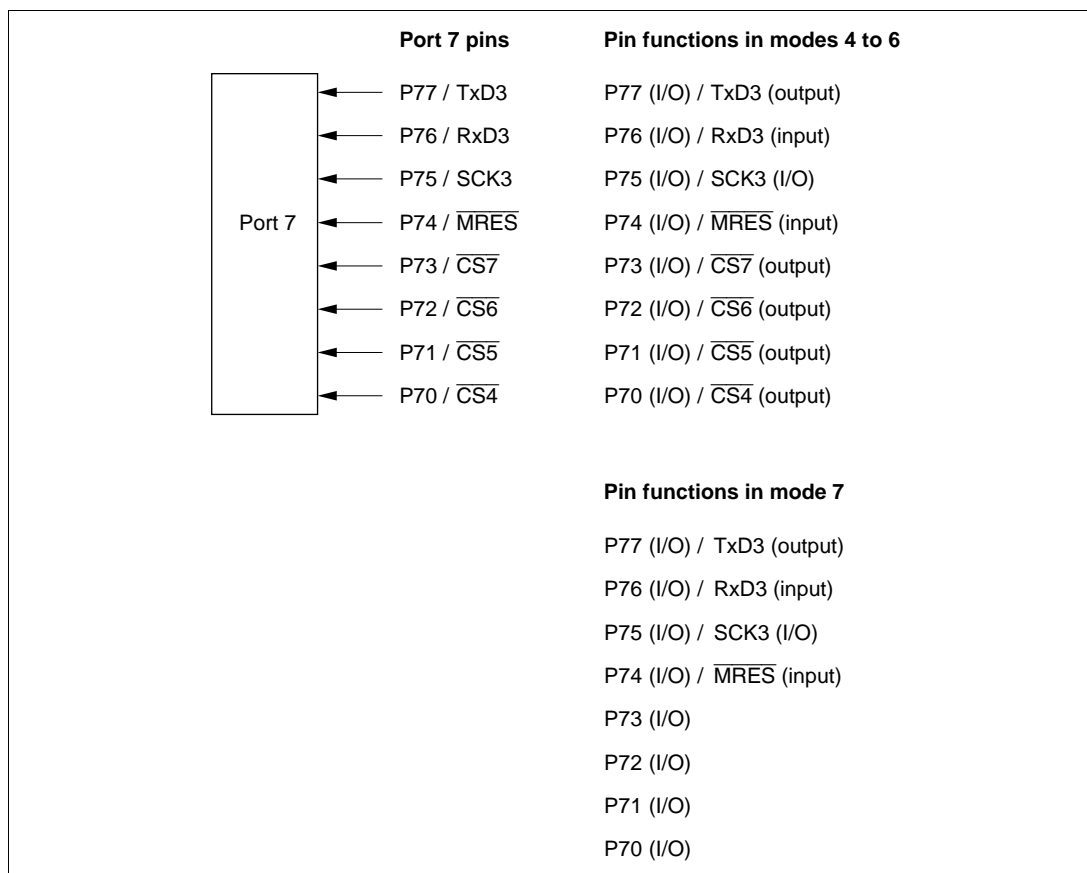


Figure 10B-4 Port 7 Pin Functions

## 10B.5.2 Register Configuration

Table 10B-7 shows the port 7 register configuration.

**Table 10B-7 Port 7 Register Configuration**

Name	Abbreviation	R/W	Initial Value	Address*
Port 7 data direction register	P7DDR	W	H'00	H'FE36
Port 7 data register	P7DR	R/W	H'00	H'FF06
Port 7 register	PORT7	R	Undefined	H'FFB6

Note: \* Lower 16 bits of the address.

### Port 7 Data Direction Register (P7DDR)

Bit	:	7	6	5	4	3	2	1	0
		P77DDR	P76DDR	P75DDR	P74DDR	P73DDR	P72DDR	P71DDR	P70DDR
Initial value	:	0	0	0	0	0	0	0	0
R/W	:	W	W	W	W	W	W	W	W

P7DDR is an 8-bit write-dedicated register, which specifies the I/O for each port 7 pin by bit. Read is disabled. If a read is carried out, undefined values are read out.

By setting P7DDR to 1, the corresponding port 7 pins become output, and by clearing to 0 they become input.

P7DDR is initialized to H'00 by a power-on reset and in hardware standby mode. The previous state is maintained by a manual reset and in software standby mode. SCI is initialized by a manual reset, so the pin state is determined by the specification of P7DDR and P7DR.



### Port 7 Data Register (P7DR)

Bit	:	7	6	5	4	3	2	1	0
		P77DR	P76DR	P75DR	P74DR	P73DR	P72DR	P71DR	P70DR
Initial value	:	0	0	0	0	0	0	0	0
R/W	:	R/W	R/W	R/W	R/W	R/W	R/W	R/W	R/W

P7DR is an 8-bit readable/writable register, which stores the output data of port 7 pins (P77 to P70).

P7DR is initialized to H'00 by a power-on reset and in hardware standby mode. The previous state is maintained by a manual reset and in software standby mode.

### Port 7 Register (PORT7)

Bit	:	7	6	5	4	3	2	1	0
		P77	P76	P75	P74	P73	P72	P71	P70
Initial value	:	—*	—*	—*	—*	—*	—*	—*	—*
R/W	:	R	R	R	R	R	R	R	R

Note: \* Determined by the state of pins P77 to P70.

PORT7 is an 8-bit read-dedicated register, which reflects the state of pins. Write is disabled. Always carry out writing off output data of port 7 pins (P77 to P70) to P7DR without fail.

When P7DDR is set to 1, if port 7 is read, the values of P7DR are read. When P7DDR is cleared to 0, if port 7 is read, the states of pins are read out.

P7DDR and P7DR are initialized by a power-on reset and in hardware standby mode, so PORT7 is determined by the state of the pins. The previous state is maintained by a manual reset and in software standby mode.

### 10B.5.3 Pin Functions

The pins of port 7 are multipurpose pins which function as bus control output pins ( $\overline{CS4}$  to  $\overline{CS7}$ ), SCI I/O pins (SCK3, RxD3, and TxD3), and manual reset input pin ( $\overline{MRES}$ ). Table 10B-8 shows the functions of port 7 pins.

**Table 10B-8 Port 7 Pin Functions**

Pin	Selection Method and Pin Functions					
P77/TxD3	Switches as follows according to combinations of SCR TE bit of SCI3, and the P77DDR bit.					
	TE	0			1	
	P77DDR	0	1	—		
	Pin function	P77 input pin	P77 output pin	TxD3 output pin		
P76/RxD3	Switches as follows according to combinations of SCR RE bit of SCI3 and the P76DDR bit.					
	RE	0			1	
	P76DDR	0	1	—		
	Pin function	P76 input pin	P76 output pin	RxD3 I/O pin		
P75/SCK3	Switches as follows according to combinations of SMR C/ $\overline{A}$ bit of SCI3, SCR CKE0 and CKE1 bits, and the P75DDR bit.					
	CKE1	0			1	
	C/ $\overline{A}$	0		1	—	
	CKE0	0		1	—	—
	P75DDR	0	1	—	—	—
	Pin function	P75 input pin	P75 output pin	SCK3 output pin	SCK3 output pin	SCK3 input pin
P74/ $\overline{MRES}$	Switches as follows according to combinations of SYSCR MRESE bit and the P74DDR bit.					
	MRESE	0			1	
	P74DDR	0	1	—		
	Pin function	P74 input pin	P74 output pin	$\overline{MRES}$ input pin		

**Pin Selection Method and Pin Functions**

**P73/ $\overline{\text{CS7}}$**  Switches as follows according to combinations of operating mode and the P73DDR bit.

Operating Mode	Modes 4 to 6		Mode 7	
P73DDR	0	1	0	1
Pin function	P73 input pin	$\overline{\text{CS7}}$ output pin	P73 input pin	P73 output pin

**P72/ $\overline{\text{CS6}}$**  Switches as follows according to combinations of operating mode and the P72DDR bit.

Operating Mode	Modes 4 to 6		Mode 7		
P72DDR	0	1	0	1	—
Pin function	P72 input pin	$\overline{\text{CS6}}$ output pin	P72 input pin	P72 output pin	TMO0 output

**P71/ $\overline{\text{CS5}}$**  Switches as follows according to operating mode and P71DDR.

Operating Mode	Modes 4 to 6		Mode 7	
P71DDR	0	1	0	1
Pin function	P71 input Pin	$\overline{\text{CS5}}$ output	P71 input pin	P71 output pin

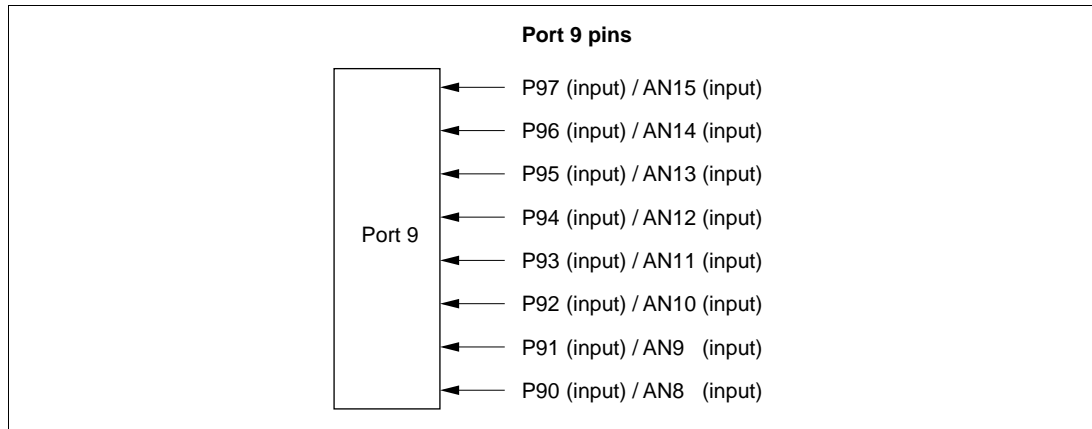
**P70/ $\overline{\text{CS4}}$**  Switches as follows according to operating mode and P70DDR.

Operating Mode	Modes 4 to 6		Mode 7	
P70DDR	0	1	0	1
Pin function	P70 input pin	$\overline{\text{CS4}}$ output	P70 input pin	P70 output pin

## 10B.6 Port 9

### 10B.6.1 Overview

Port 9 is an 8-bit input-only port. Port 9 pins also function as A/D converter analog input pins (AN8 to AN15). Port 9 pin functions are the same in all operating modes. Figure 10B-5 shows the port 9 pin configuration.



**Figure 10B-5 Port 9 Pin Functions**

### 10B.6.2 Register Configuration

Table 10B-9 shows the port 9 register configuration. Port 9 is an input-only port, and does not have a data direction register or data register.

**Table 10B-9 Port 9 Registers**

Name	Abbreviation	R/W	Initial Value	Address*
Port 9 register	PORT9	R	Undefined	H'FFB8

Note: \* Lower 16 bits of the address.

**Port 9 Register (PORT9):** The pin states are always read when a port 9 read is performed.

Bit	:	7	6	5	4	3	2	1	0
		P97	P96	P95	P94	P93	P92	P91	P90
Initial value :		—*	—*	—*	—*	—*	—*	—*	—*
R/W	:	R	R	R	R	R	R	R	R

Note: \* Determined by state of pins P97 to P90.

### 10B.6.3 Pin Functions

Port 9 pins function as A/D converter analog input pins (AN8 to AN15).

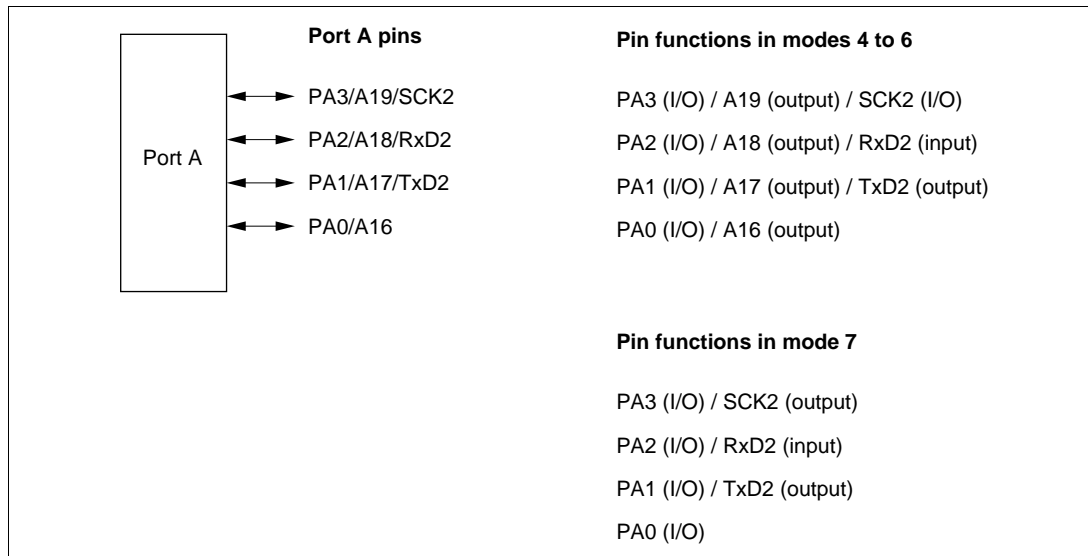
## 10B.7 Port A

### 10B.7.1 Overview

Port A is a 4-bit I/O port. Port A pins also function as address bus outputs and SCI2 I/O pins (SCK2, RxD2, and TxD2). The pin functions change according to the operating mode.

Port A has a built-in MOS input pull-up function that can be controlled by software.

Figure 10B-6 shows the port A pin configuration.



**Figure 10B-6 Port A Pin Functions**

## 10B.7.2 Register Configuration

Table 10B-10 shows the port A register configuration.

**Table 10B-10 Port A Registers**

Name	Abbreviation	R/W	Initial Value* <sup>2</sup>	Address* <sup>1</sup>
Port A data direction register	PADDR	W	H'0	H'FE39
Port A data register	PADR	R/W	H'0	H'FF09
Port A register	PORTA	R	Undefined	H'FFB9
Port A MOS pull-up control register	PAPCR	R/W	H'0	H'FE40
Port A open-drain control register	PAODR	R/W	H'0	H'FE47

Notes: \*1 Lower 16 bits of the address.

\*2 Value of bits 3 to 0.

### Port A Data Direction Register (PADDR)

Bit	7	6	5	4	3	2	1	0
	—	—	—	—	PA3DDR	PA2DDR	PA1DDR	PA0DDR
Initial value :	Undefined	Undefined	Undefined	Undefined	0	0	0	0
R/W :	—	—	—	—	W	W	W	W

PADDR is an 8-bit write-only register, the individual bits of which specify input or output for the pins of port A. PADDR cannot be read; if it is, an undefined value will be read.

Bits 7 and 6 are reserved; they return an undetermined value if read.

PADDR is initialized to H'0 (bits 3 to 0) by a power-on reset, and in hardware standby mode. It retains its prior state by a manual reset or in software standby mode. The OPE bit in SBYCR is used to select whether the address output pins retain their output state or become high-impedance when a transition is made to software standby mode.

- Modes 4 to 6

The corresponding port A pins become address outputs in accordance with the setting of bits AE3 to AE0 in PFCR, irrespective of the value of bits PA4DDR to PA0DDR. When pins are not used as address outputs, setting a PADDR bit to 1 makes the corresponding port A pin an output port, while clearing the bit to 0 makes the pin an input port.

- Mode 7

Setting a PADDR bit to 1 makes the corresponding port A pin an output port, while clearing the bit to 0 makes the pin an input port.

### Port A Data Register (PADR)

Bit	:	7	6	5	4	3	2	1	0
		—	—	—	—	PA3DR	PA2DR	PA1DR	PA0DR
Initial value	:	Undefined	Undefined	Undefined	Undefined	0	0	0	0
R/W	:	—	—	—	—	R/W	R/W	R/W	R/W

PADR is an 8-bit readable/writable register that stores output data for the port A pins (PA7 to PA0).

Bits 7 to 4 are reserved; they return an undetermined value if read, and cannot be modified.

PADR is initialized to H'0 (bits 3 to 0) by a power-on reset, and in hardware standby mode. It retains its prior state by a manual reset or in software standby mode.

### Port A Register (PORTA)

Bit	:	7	6	5	4	3	2	1	0
		—	—	—	—	PA3	PA2	PA1	PA0
Initial value	:	Undefined	Undefined	Undefined	Undefined	—*	—*	—*	—*
R/W	:	—	—	—	—	R	R	R	R

Note: \* Determined by state of pins PA3 to PA0.

PORTA is an 8-bit read-only register that shows the pin states. It cannot be written to. Writing of output data for the port A pins (PA7 to PA0) must always be performed on PADR.

Bits 7 to 4 are reserved; they return an undetermined value if read, and cannot be modified.

If a port A read is performed while PADR bits are set to 1, the PADR values are read. If a port A read is performed while PADR bits are cleared to 0, the pin states are read.

After a power-on reset and in hardware standby mode, PORTA contents are determined by the pin states, as PADR and PADR are initialized. PORTA retains its prior state by a manual reset or in software standby mode.



### Port A MOS Pull-Up Control Register (PAPCR)

Bit	:	7	6	5	4	3	2	1	0
		—	—	—	—	PA3PCR	PA2PCR	PA1PCR	PA0PCR
Initial value	:	Undefined	Undefined	Undefined	Undefined	0	0	0	0
R/W	:	—	—	—	—	R/W	R/W	R/W	R/W

PAPCR is an 8-bit readable/writable register that controls the MOS input pull-up function incorporated into port A on an individual bit basis.

Bits 7 to 4 are reserved; they return an undetermined value if read, and cannot be modified. In modes 4 to 6, if a pin is in the input state in accordance with the settings in PFCR, in the SCI's SCMR, SMR, and SCR, and in DDR, setting the corresponding PAPCR bit to 1 turns on the MOS input pull-up for that pin.

In mode 7, if a pin is in the input state in accordance with the settings in the SCI's SCMR, SMR, and SCR, and in DDR, setting the corresponding PAPCR bit to 1 turns on the MOS input pull-up for that pin.

PAPCR is initialized by a manual reset or to H'0 (bits 3 to 0) by a power-on reset, and in hardware standby mode. It retains its prior state in software standby mode.

### Port A Open Drain Control Register (PAODR)

Bit	:	7	6	5	4	3	2	1	0
		—	—	—	—	PA3ODR	PA2ODR	PA1ODR	PA0ODR
Initial value	:	Undefined	Undefined	Undefined	Undefined	0	0	0	0
R/W	:	—	—	—	—	R/W	R/W	R/W	R/W

PAODR is an 8-bit readable/writable register that controls whether PMOS is on or off for each port A pin (PA7 to PA0).

Bits 7 to 4 are reserved; they return an undetermined value if read, and cannot be modified.

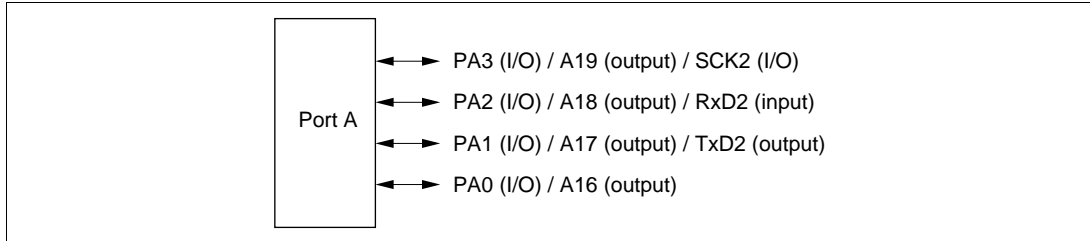
When pins are not address outputs in accordance with the setting of bits AE3 to AE0 in PFCR, setting a PAODR bit makes the corresponding port A pin an NMOS open-drain output, while clearing the bit to 0 makes the pin a CMOS output.

PAODR is initialized to H'0 (bits 3 to 0) by a power-on reset, and in hardware standby mode. It retains its prior state by a manual reset or in software standby mode.

### 10B.7.3 Pin Functions

**Modes 4 to 6:** In modes 4 to 6, port A pins function as address outputs according to the setting of AE3 to AE0 in PFCR; when they do not function as address outputs, the pins function as SCI I/O pins and I/O ports.

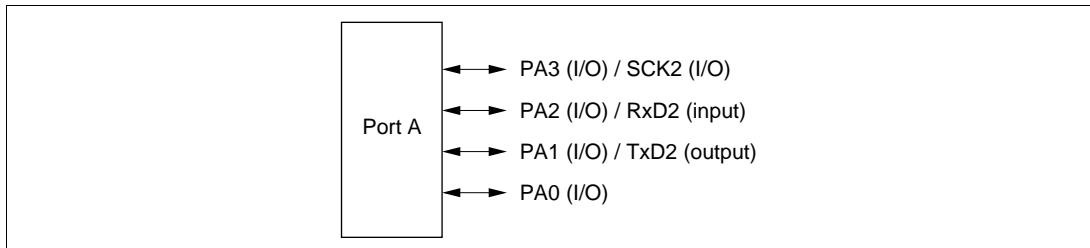
Port A pin functions in modes 4 to 6 are shown in figure 10B-7.



**Figure 10B-7 Port A Pin Functions (Modes 4 to 6)**

**Mode 7:** In mode 7, port A pins function as I/O ports and SCI2 I/O pins (SCK2, TxD2, and RxD2). Input or output can be specified for each pin on an individual bit basis. Setting a PADDR bit to 1 makes the corresponding port A pin an output port, while clearing the bit to 0 makes the pin an input port.

Port A pin functions are shown in figure 10B-8.



**Figure 10B-8 Port A Pin Functions (Mode 7)**

#### 10B.7.4 MOS Input Pull-Up Function

Port A has a built-in MOS input pull-up function that can be controlled by software. MOS input pull-up can be specified as on or off on an individual bit basis.

In modes 4 to 6, if a pin is in the input state in accordance with the settings in PFCR, in the SCI's SCMR, SMR, and SCR, and in DDR, setting the corresponding PAPCR bit to 1 turns on the MOS input pull-up for that pin.

In mode 7, if a pin is in the input state in accordance with the settings in the SCI's SCMR, SMR, and SCR, and in DDR, setting the corresponding PAPCR bit to 1 turns on the MOS input pull-up for that pin.

The MOS input pull-up function is in the off state after a power-on reset, and in hardware standby mode. The prior state is retained by a manual reset or in software standby mode.

Table 10B-11 summarizes the MOS input pull-up states.

**Table 10B-11 MOS Input Pull-Up States (Port A)**

Pin States	Power-On Reset	Hardware Standby Mode	Manual Reset	Software Standby Mode	In Other Operations
Address output or SCI output	OFF	OFF	OFF	OFF	OFF
Other than above			ON/OFF	ON/OFF	ON/OFF

**Legend:**

OFF : MOS input pull-up is always off.

ON/OFF : On when PADDR = 0 and PAPCR = 1; otherwise off.

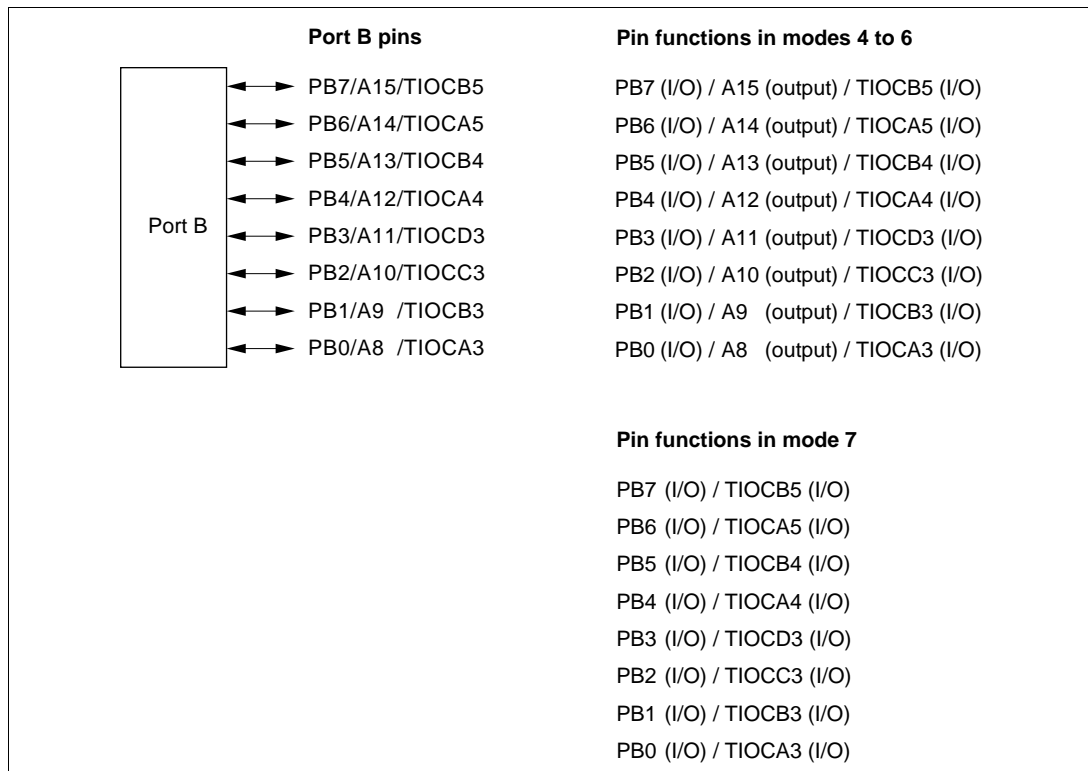
## 10B.8 Port B

### 10B.8.1 Overview

Port B is an 8-bit I/O port. Port B pins also function as TPU I/O pins (TIOCA3, TIOCB3, TIOCC3, TIOCD3, TIOCA4, TIOCB4, TIOCA5, and TIOCB5) and as address outputs; the pin functions change according to the operating mode.

Port B has a built-in MOS input pull-up function that can be controlled by software.

Figure 10B-9 shows the port B pin configuration.



**Figure 10B-9 Port B Pin Functions**

## 10B.8.2 Register Configuration

Table 10B-12 shows the port B register configuration.

**Table 10B-12 Port B Registers**

Name	Abbreviation	R/W	Initial Value	Address*
Port B data direction register	PBDDR	W	H'00	H'FE3A
Port B data register	PBDR	R/W	H'00	H'FF0A
Port B register	PORTB	R	Undefined	H'FFBA
Port B MOS pull-up control register	PBPCR	R/W	H'00	H'FE41
Port B open-drain control register	PBODR	R/W	H'00	H'FE48

Note: \* Lower 16 bits of the address.

### Port B Data Direction Register (PBDDR)

Bit	:	7	6	5	4	3	2	1	0
		PB7DDR	PB6DDR	PB5DDR	PB4DDR	PB3DDR	PB2DDR	PB1DDR	PB0DDR
Initial value :		0	0	0	0	0	0	0	0
R/W	:	W	W	W	W	W	W	W	W

PBDDR is an 8-bit write-only register, the individual bits of which specify input or output for the pins of port B. PBDDR cannot be read; if it is, an undefined value will be read.

PBDDR is initialized to H'00 by a power-on reset, and in hardware standby mode. It retains its prior state by a manual reset or in software standby mode. The OPE bit in SBYCR is used to select whether the address output pins retain their output state or become high-impedance when a transition is made to software standby mode.

- Modes 4 to 6

The corresponding port B pins become address outputs in accordance with the setting of bits AE3 to AE0 in PFCR, irrespective of the value of the PBDDR bits. When pins are not used as address outputs, setting a PBDDR bit to 1 makes the corresponding port B pin an output port, while clearing the bit to 0 makes the pin an input port.

- Mode 7

Setting a PBDDR bit to 1 makes the corresponding port B pin an output port, while clearing the bit to 0 makes the pin an input port.

### Port B Data Register (PBDR)

Bit	:	7	6	5	4	3	2	1	0
		PB7DR	PB6DR	PB5DR	PB4DR	PB3DR	PB2DR	PB1DR	PB0DR
Initial value :		0	0	0	0	0	0	0	0
R/W	:	R/W	R/W	R/W	R/W	R/W	R/W	R/W	R/W

PBDR is an 8-bit readable/writable register that stores output data for the port B pins (PB7 to PB0). PBDR is initialized to H'00 by a power-on reset, and in hardware standby mode. It retains its prior state by a manual reset or in software standby mode.

### Port B Register (PORTB)

Bit	:	7	6	5	4	3	2	1	0
		PB7	PB6	PB5	PB4	PB3	PB2	PB1	PB0
Initial value :		—*	—*	—*	—*	—*	—*	—*	—*
R/W	:	R	R	R	R	R	R	R	R

Note: \* Determined by state of pins PB7 to PB0.

PORTB is an 8-bit read-only register that shows the pin states. It cannot be written to. Writing of output data for the port B pins (PB7 to PB0) must always be performed on PBDR.

If a port B read is performed while PBDDR bits are set to 1, the PBDR values are read. If a port B read is performed while PBDDR bits are cleared to 0, the pin states are read.

After a power-on reset and in hardware standby mode, PORTB contents are determined by the pin states, as PBDDR and PBDR are initialized. PORTB retains its prior state in software standby mode.

### Port B MOS Pull-Up Control Register (PBPCR)

Bit	:	7	6	5	4	3	2	1	0
		PB7PCR	PB6PCR	PB5PCR	PB4PCR	PB3PCR	PB2PCR	PB1PCR	PB0PCR
Initial value :		0	0	0	0	0	0	0	0
R/W	:	R/W	R/W	R/W	R/W	R/W	R/W	R/W	R/W

PBPCR is an 8-bit readable/writable register that controls the MOS input pull-up function incorporated into port B on an individual bit basis.

In modes 4 to 6, if a pin is in the input state in accordance with the settings in PFCR, in the TPU's TIOR, and in DDR, setting the corresponding PBPCR bit to 1 turns on the MOS input pull-up for that pin.

In mode 7, if a pin is in the input state in accordance with the settings in the TPU's TIOR and in DDR, setting the corresponding PBPCR bit to 1 turns on the MOS input pull-up for that pin.

PBPCR is initialized to H'00 by a power-on reset, and in hardware standby mode. It retains its prior state by a manual reset or in software standby mode.

### Port B Open Drain Control Register (PBODR)

Bit	:	7	6	5	4	3	2	1	0
		PB7ODR	PB6ODR	PB5ODR	PB4ODR	PB3ODR	PB2ODR	PB1ODR	PB0ODR
Initial value :		0	0	0	0	0	0	0	0
R/W	:	R/W	R/W	R/W	R/W	R/W	R/W	R/W	R/W

PBODR is an 8-bit readable/writable register that controls the PMOS on/off state for each port B pin (PB7 to PB0).

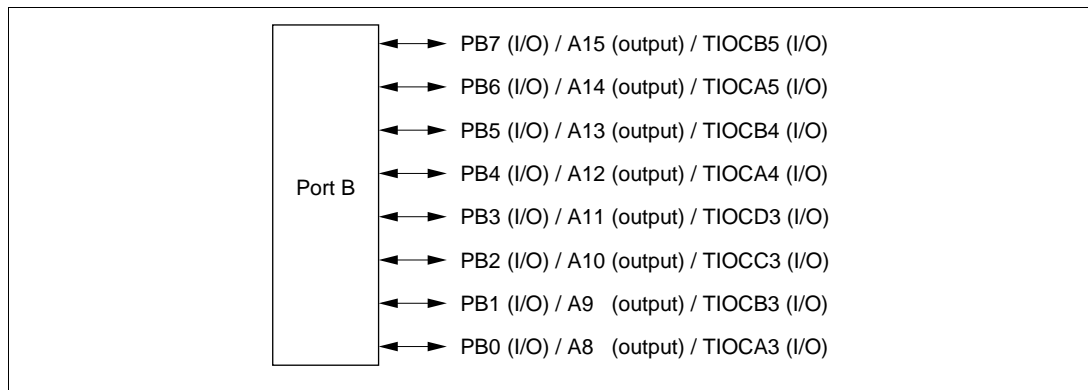
When pins are not address outputs in accordance with the setting of bits AE3 to AE0 in PFCR, setting a PBODR bit makes the corresponding port B pin an NMOS open-drain output, while clearing the bit to 0 makes the pin a CMOS output.

PBODR is initialized to H'00 by a power-on reset, and in hardware standby mode. It retains its prior state by a manual reset or in software standby mode.

### 10B.8.3 Pin Functions

**Modes 4 to 6:** In modes 4 to 6, the corresponding port B pins become address outputs in accordance with the setting of bits AE3 to AE0 in PFCR. When pins are not used as address outputs, they function as TPU I/O pins and I/O ports.

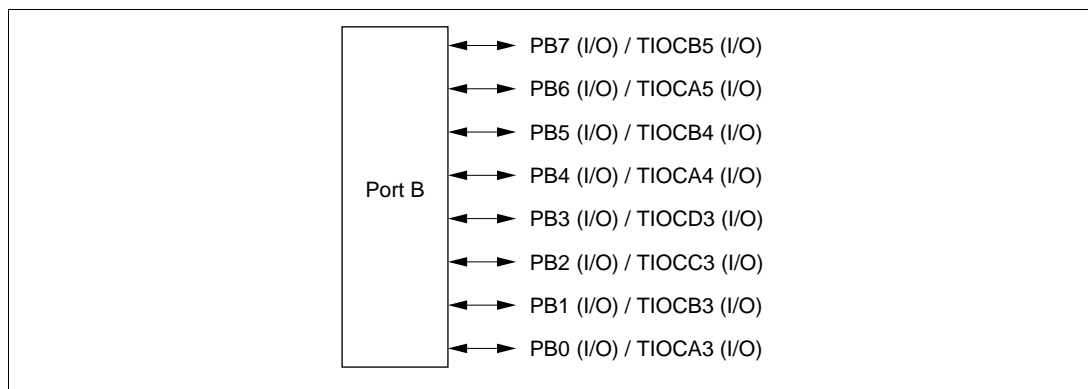
Port B pin functions in modes 4 to 6 are shown in figure 10B-10.



**Figure 10B-10 Port B Pin Functions (Modes 4 to 6)**

**Mode 7:** In mode 7, port B pins function as I/O ports and TPU I/O pins (TIOCA3, TIOCB3, TIOCC3, TIOCD3, TIOCA4, TIOCB4, TIOCA5, and TIOCB5). Input or output can be specified for each pin on an individual bit basis. Setting a PBDDR bit to 1 makes the corresponding port B pin an output port, while clearing the bit to 0 makes the pin an input port.

Port B pin functions in mode 7 are shown in figure 10B-11.



**Figure 10B-11 Port B Pin Functions (Mode 7)**



### 10B.8.4 MOS Input Pull-Up Function

Port B has a built-in MOS input pull-up function that can be controlled by software. MOS input pull-up can be specified as on or off on an individual bit basis.

In modes 4 to 6, if a pin is in the input state in accordance with the settings in PFCR, in the TPU's TIOR, and in DDR, setting the corresponding PBPCR bit to 1 turns on the MOS input pull-up for that pin.

In mode 7, if a pin is in the input state in accordance with the settings in the TPU's TIOR and in DDR, setting the corresponding PBPCR bit to 1 turns on the MOS input pull-up for that pin.

The MOS input pull-up function is in the off state after a power-on reset, and in hardware standby mode. The prior state is retained by a manual reset or in software standby mode.

Table 10B-13 summarizes the MOS input pull-up states.

**Table 10B-13 MOS Input Pull-Up States (Port B)**

Pin States	Power-On Reset	Hardware Standby Mode	Manual Reset	Software Standby Mode	In Other Operations
Address output or TPU output	OFF	OFF	OFF	OFF	OFF
Other than above			ON/OFF	ON/OFF	ON/OFF

**Legend:**

OFF : MOS input pull-up is always off.

ON/OFF : On when PBDDR = 0 and PBPCR = 1; otherwise off.

## 10B.9 Port C

### 10B.9.1 Overview

Port C is an 8-bit I/O port. Port C has an address bus output function. The pin functions change according to the operating mode.

Port C has a built-in MOS input pull-up function that can be controlled by software.

Figure 10B-12 shows the port C pin configuration.

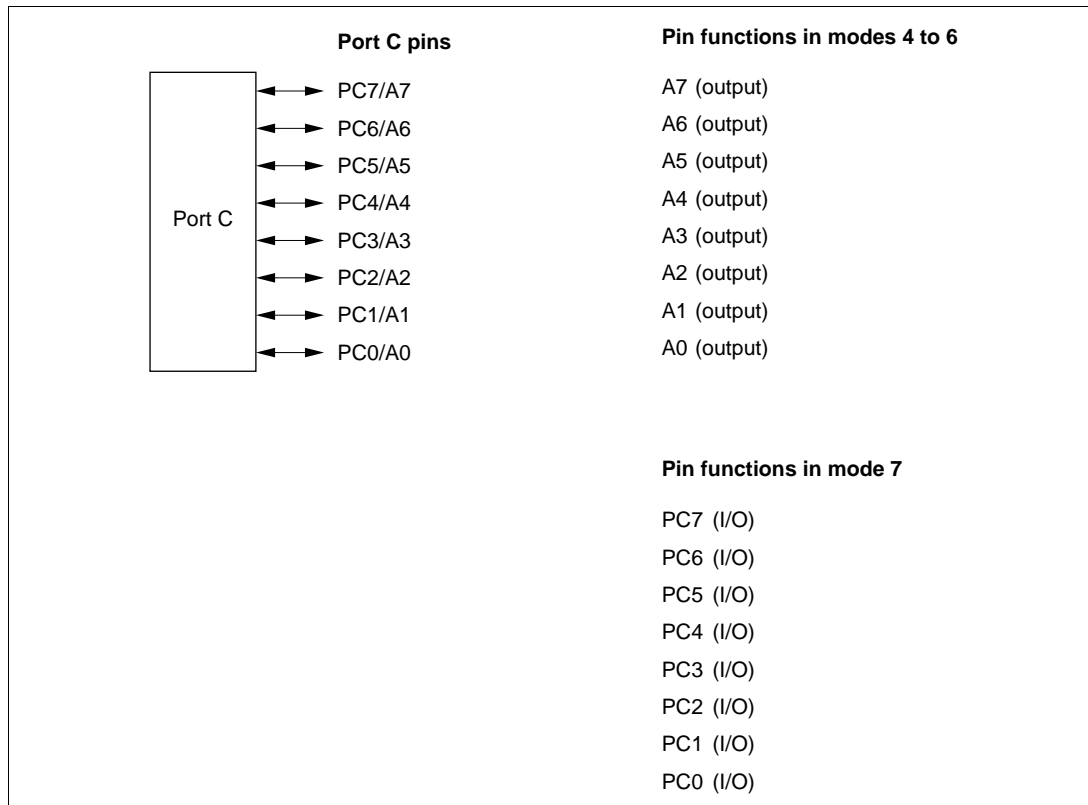


Figure 10B-12 Port C Pin Functions

## 10B.9.2 Register Configuration

Table 10B-14 shows the port C register configuration.

**Table 10B-14 Port C Registers**

Name	Abbreviation	R/W	Initial Value	Address*
Port C data direction register	PCDDR	W	H'00	H'FE3B
Port C data register	PCDR	R/W	H'00	H'FF0B
Port C register	PORTC	R	Undefined	H'FFBB
Port C MOS pull-up control register	PCPCR	R/W	H'00	H'FE42
Port C open-drain control register	PCODR	R/W	H'00	H'FE49

Note: \* Lower 16 bits of the address.

### Port C Data Direction Register (PCDDR)

Bit	:	7	6	5	4	3	2	1	0
		PC7DDR	PC6DDR	PC5DDR	PC4DDR	PC3DDR	PC2DDR	PC1DDR	PC0DDR
Initial value :		0	0	0	0	0	0	0	0
R/W	:	W	W	W	W	W	W	W	W

PCDDR is an 8-bit write-only register, the individual bits of which specify input or output for the pins of port C. PCDDR cannot be read; if it is, an undefined value will be read.

PCDDR is initialized to H'00 by a power-on reset, and in hardware standby mode. It retains its prior state by a manual reset or in software standby mode. The OPE bit in SBYCR is used to select whether the address output pins retain their output state or become high-impedance when the mode is changed to software standby mode.

- Modes 4 and 5  
The corresponding port C pins are address outputs irrespective of the value of the PCDDR bits.
- Mode 6  
Setting a PCDDR bit to 1 makes the corresponding port C pin an address output, while clearing the bit to 0 makes the pin an input port.
- Mode 7  
Setting a PCDDR bit to 1 makes the corresponding port C pin an output port, while clearing the bit to 0 makes the pin an input port.

### Port C Data Register (PCDR)

Bit	:	7	6	5	4	3	2	1	0
		PC7DR	PC6DR	PC5DR	PC4DR	PC3DR	PC2DR	PC1DR	PC0DR
Initial value :		0	0	0	0	0	0	0	0
R/W	:	R/W	R/W	R/W	R/W	R/W	R/W	R/W	R/W

PCDR is an 8-bit readable/writable register that stores output data for the port C pins (PC7 to PC0).

PCDR is initialized to H'00 by a power-on reset, and in hardware standby mode. It retains its prior state by a manual reset or in software standby mode.

### Port C Register (PORTC)

Bit	:	7	6	5	4	3	2	1	0
		PC7	PC6	PC5	PC4	PC3	PC2	PC1	PC0
Initial value :		—*	—*	—*	—*	—*	—*	—*	—*
R/W	:	R	R	R	R	R	R	R	R

Note: \* Determined by state of pins PC7 to PC0.

PORTC is an 8-bit read-only register that shows the pin states. It cannot be written to. Writing of output data for the port C pins (PC7 to PC0) must always be performed on PCDR.

If a port C read is performed while PCDDR bits are set to 1, the PCDR values are read. If a port C read is performed while PCDDR bits are cleared to 0, the pin states are read.

After a power-on reset and in hardware standby mode, PORTC contents are determined by the pin states, as PCDDR and PCDR are initialized. PORTC retains its prior state by a manual reset or in software standby mode.

### Port C MOS Pull-Up Control Register (PCPCR)

Bit	:	7	6	5	4	3	2	1	0
		PC7PCR	PC6PCR	PC5PCR	PC4PCR	PC3PCR	PC2PCR	PC1PCR	PC0PCR
Initial value :		0	0	0	0	0	0	0	0
R/W	:	R/W	R/W	R/W	R/W	R/W	R/W	R/W	R/W

PCPCR is an 8-bit readable/writable register that controls the MOS input pull-up function incorporated into port C on an individual bit basis.

In modes 6 and 7, if PCPCR is set to 1 when the port is in the input state in accordance with the settings of PCDDR, the MOS input pull-up is set to ON.

PCPCR is initialized to H'00 by a power-on reset, and in hardware standby mode. It retains its prior state by a manual reset or in software standby mode.

### Port C Open Drain Control Register (PCODR)

Bit	:	7	6	5	4	3	2	1	0
		PC7ODR	PC6ODR	PC5ODR	PC4ODR	PC3ODR	PC2ODR	PC1ODR	PC0ODR
Initial value :		0	0	0	0	0	0	0	0
R/W	:	R/W	R/W	R/W	R/W	R/W	R/W	R/W	R/W

PCDDR is an 8-bit read/write register and controls PMOS on/off of each pin (PC7 to PC0) of port C.

If PCODR is set to 1 by setting AE3 to AE0 in PFCR in mode other than address output mode, port C pins function as NMOS open drain outputs and when the setting is cleared to 0, the pins function as CMOS outputs.

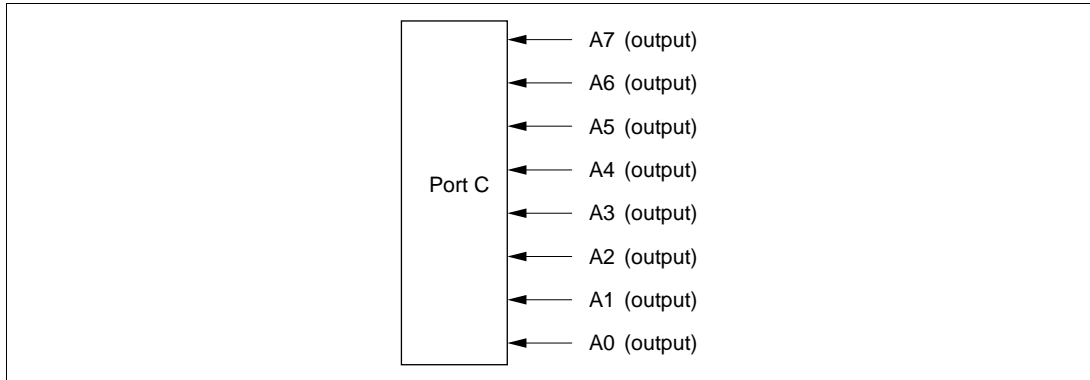
PCODR is initialized to H'00 in power-on reset mode or hardware standby mode. PCODR retains the last state in manual reset mode or software standby mode.

### 10B.9.3 Pin Functions for Each Mode

#### (1) Modes 4 and 5

In modes 4 and 5, port C pins function as address outputs automatically.

Figure 10B-13 shows the port C pin functions.

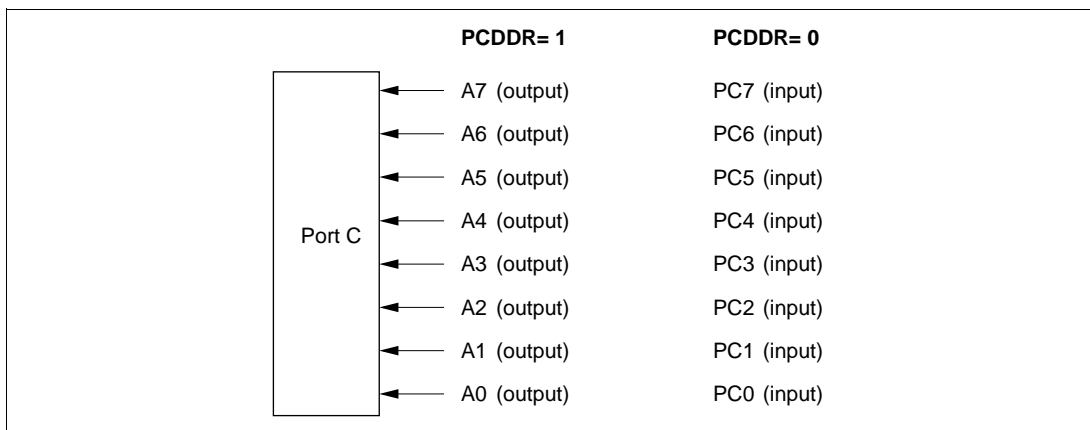


**Figure 10B-13 Port C Pin Functions (Modes 4 and 5)**

#### (2) Mode 6

In mode 6, port C pins function as address outputs or input ports and I/O can be specified in bit units. When each bit in PCDDR is set to 1, the corresponding pin functions as an address output and when the bit cleared to 0, the pin functions as an input port.

Figure 10B-14 shows the port C pin functions.

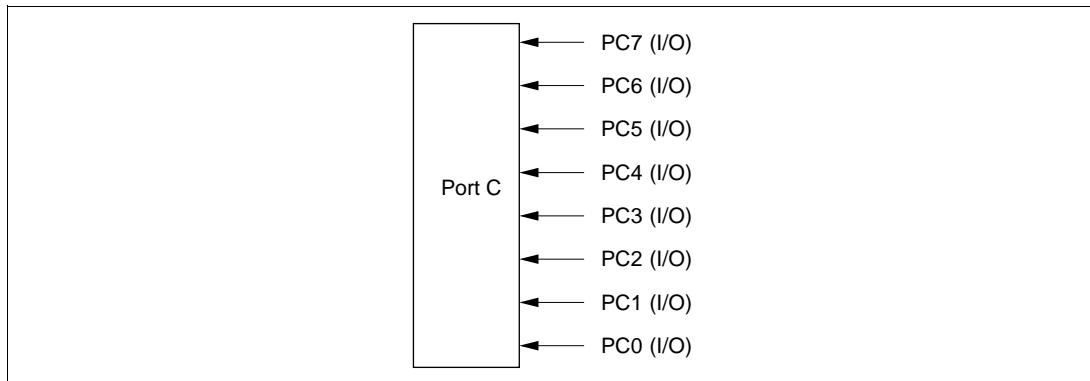


**Figure 10B-14 Port C Pin Functions (Mode 6)**

### (3) Mode 7

In mode 7, port C pins function as I/O ports and I/O can be specified for each pin in bit units. When each bit in PCDDR is set to 1, the corresponding pin functions as an output port and when the bit is cleared to 0, the pin functions as an input port.

Figure 10B-15 shows the port C pin functions.



**Figure 10B-15 Port C Pin Functions (Mode 7)**

#### 10B.9.4 MOS Input Pull-Up Function

Port C has a built-in MOS input pull-up function that can be controlled by software. This MOS input pull-up function can be used in modes 6 and 7, and can be specified as on or off on an individual bit basis.

In modes 6 and 7, when PCPCR is set to 1 in the input state by setting of PCDDR, the MOS input pull-up is set to ON.

The MOS input pull-up function is in the off state after a power-on reset, and in hardware standby mode. The prior state is retained by a manual reset or in software standby mode.

Table 10B-15 summarizes the MOS input pull-up states.

**Table 10B-15 MOS Input Pull-Up States (Port C)**

<b>Pin States</b>	<b>Power-On Reset</b>	<b>Hardware Standby Mode</b>	<b>Manual Reset</b>	<b>Software Standby Mode</b>	<b>In Other Operations</b>
Address output	OFF	OFF	OFF	OFF	OFF
Other than above			ON/OFF	ON/OFF	ON/OFF

**Legend:**

OFF : MOS input pull-up is always off.

ON/OFF : On when PCDDR = 0 and PCPCR = 1; otherwise off.



## 10B.10 Port D

### 10B.10.1 Overview

Port D is an 8-bit I/O port. Port D has a data bus I/O function, and the pin functions change according to the operating mode.

Port D has a built-in MOS input pull-up function that can be controlled by software.

Figure 10B-16 shows the port D pin configuration.

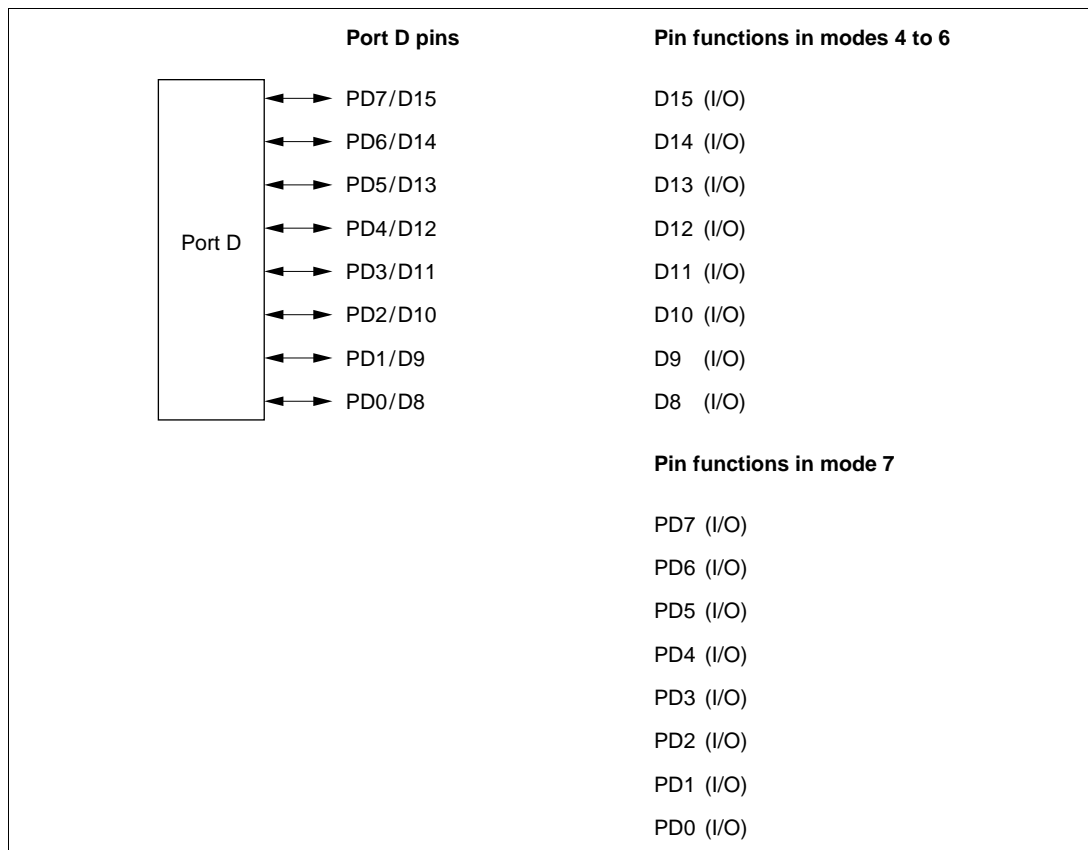


Figure 10B-16 Port D Pin Functions

### 10B.10.2 Register Configuration

Table 10B-16 shows the port D register configuration.

**Table 10B-16 Port D Registers**

Name	Abbreviation	R/W	Initial Value	Address*
Port D data direction register	PDDDR	W	H'00	H'FE3C
Port D data register	PDDR	R/W	H'00	H'FF0C
Port D register	PORTD	R	Undefined	H'FFBC
Port D MOS pull-up control register	PDPCR	R/W	H'00	H'FE43

Note: \* Lower 16 bits of the address.

#### Port D Data Direction Register (PDDDR)

Bit	:	7	6	5	4	3	2	1	0
		PD7DDR	PD6DDR	PD5DDR	PD4DDR	PD3DDR	PD2DDR	PD1DDR	PD0DDR
Initial value :		0	0	0	0	0	0	0	0
R/W	:	W	W	W	W	W	W	W	W

PDDDR is an 8-bit write-only register, the individual bits of which specify input or output for the pins of port D. PDDDR cannot be read; if it is, an undefined value will be read.

PDDDR is initialized to H'00 by a power-on reset, and in hardware standby mode. It retains its prior state by a manual reset or in software standby mode.

- Modes 4 to 6  
The input/output direction specification by PDDDR is ignored, and port D is automatically designated for data I/O.
- Mode 7  
Setting a PDDDR bit to 1 makes the corresponding port D pin an output port, while clearing the bit to 0 makes the pin an input port.

### Port D Data Register (PDDR)

Bit	:	7	6	5	4	3	2	1	0
		PD7DR	PD6DR	PD5DR	PD4DR	PD3DR	PD2DR	PD1DR	PD0DR
Initial value :		0	0	0	0	0	0	0	0
R/W	:	R/W	R/W	R/W	R/W	R/W	R/W	R/W	R/W

PDDR is an 8-bit readable/writable register that stores output data for the port D pins (PD7 to PD0).

PDDR is initialized to H'00 by a power-on reset, and in hardware standby mode. It retains its prior state by a manual reset or in software standby mode.

### Port D Register (PORTD)

Bit	:	7	6	5	4	3	2	1	0
		PD7	PD6	PD5	PD4	PD3	PD2	PD1	PD0
Initial value :		—*	—*	—*	—*	—*	—*	—*	—*
R/W	:	R	R	R	R	R	R	R	R

Note: \* Determined by state of pins PD7 to PD0.

PORTD is an 8-bit read-only register that shows the pin states. It cannot be written to. Writing of output data for the port D pins (PD7 to PD0) must always be performed on PDDR.

If a port D read is performed while PDDDR bits are set to 1, the PDDR values are read. If a port D read is performed while PDDDR bits are cleared to 0, the pin states are read.

After a power-on reset and in hardware standby mode, PORTD contents are determined by the pin states, as PDDDR and PDDR are initialized. PORTD retains its prior state by a manual reset or in software standby mode.

### Port D MOS Pull-Up Control Register (PDPCR)

Bit	:	7	6	5	4	3	2	1	0
		PD7PCR	PD6PCR	PD5PCR	PD4PCR	PD3PCR	PD2PCR	PD1PCR	PD0PCR
Initial value :		0	0	0	0	0	0	0	0
R/W	:	R/W	R/W	R/W	R/W	R/W	R/W	R/W	R/W

PDPCR is an 8-bit readable/writable register that controls the MOS input pull-up function incorporated into port D on an individual bit basis.

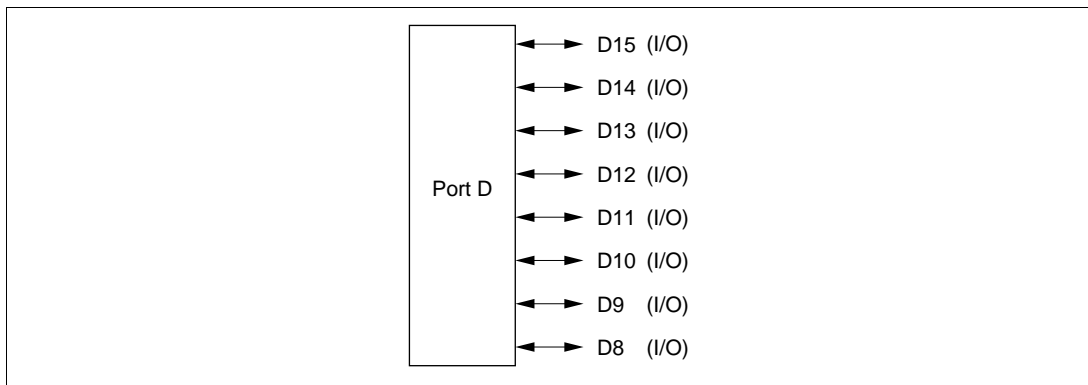
When a PDDDR bit is cleared to 0 (input port setting) in mode 7, setting the corresponding PDPCR bit to 1 turns on the MOS input pull-up for the corresponding pin.

PDPCR is initialized to H'00 by a power-on reset, and in hardware standby mode. It retains its prior state by a manual reset or in software standby mode.

### 10B.10.3 Pin Functions

**Modes 4 to 6:** In modes 4 to 6, port D pins are automatically designated as data I/O pins.

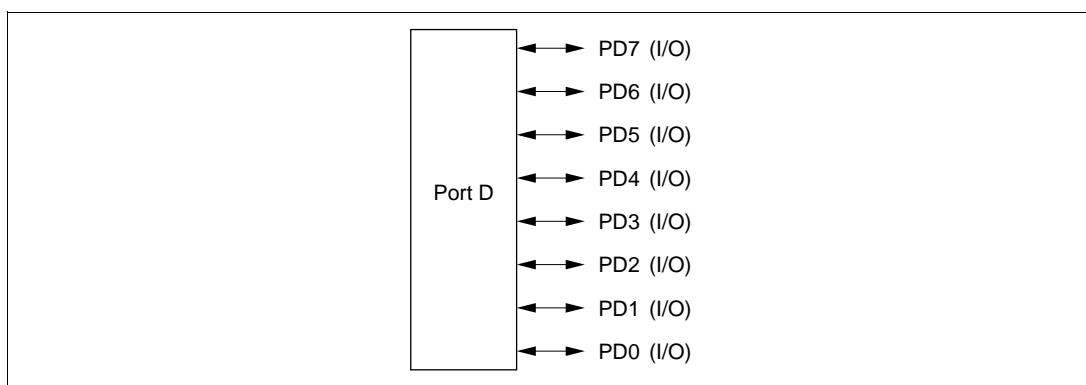
Port D pin functions in modes 4 to 6 are shown in figure 10B-17.



**Figure 10B-17 Port D Pin Functions (Modes 4 to 6)**

**Mode 7:** In mode 7, port D pins function as I/O ports. Input or output can be specified for each pin on an individual bit basis. Setting a PDDDR bit to 1 makes the corresponding port D pin an output port, while clearing the bit to 0 makes the pin an input port.

Port D pin functions in mode 7 are shown in figure 10B-18.



**Figure 10B-18 Port D Pin Functions (Mode 7)**

#### 10B.10.4 MOS Input Pull-Up Function

Port D has a built-in MOS input pull-up function that can be controlled by software. This MOS input pull-up function can be used in mode 7, and can be specified as on or off on an individual bit basis.

When a PDDDR bit is cleared to 0 in mode 7, setting the corresponding PDPCR bit to 1 turns on the MOS input pull-up for that pin.

The MOS input pull-up function is in the off state after a power-on reset, and in hardware standby mode. The prior state is retained by a manual reset or in software standby mode.

Table 10B-17 summarizes the MOS input pull-up states.

**Table 10B-17 MOS Input Pull-Up States (Port D)**

Modes	Power-On Reset	Hardware Standby Mode	Manual Reset	Software Standby Mode	In Other Operations
4 to 6	OFF	OFF	OFF	OFF	OFF
7			ON/OFF	ON/OFF	ON/OFF

**Legend:**

OFF : MOS input pull-up is always off.

ON/OFF : On when PDDDR = 0 and PDPCR = 1; otherwise off.

## 10B.11 Port E

### 10B.11.1 Overview

Port E is an 8-bit I/O port. Port E has a data bus I/O function, and the pin functions change according to the operating mode and whether 8-bit or 16-bit bus mode is selected.

Port E has a built-in MOS input pull-up function that can be controlled by software.

Figure 10B-19 shows the port E pin configuration.

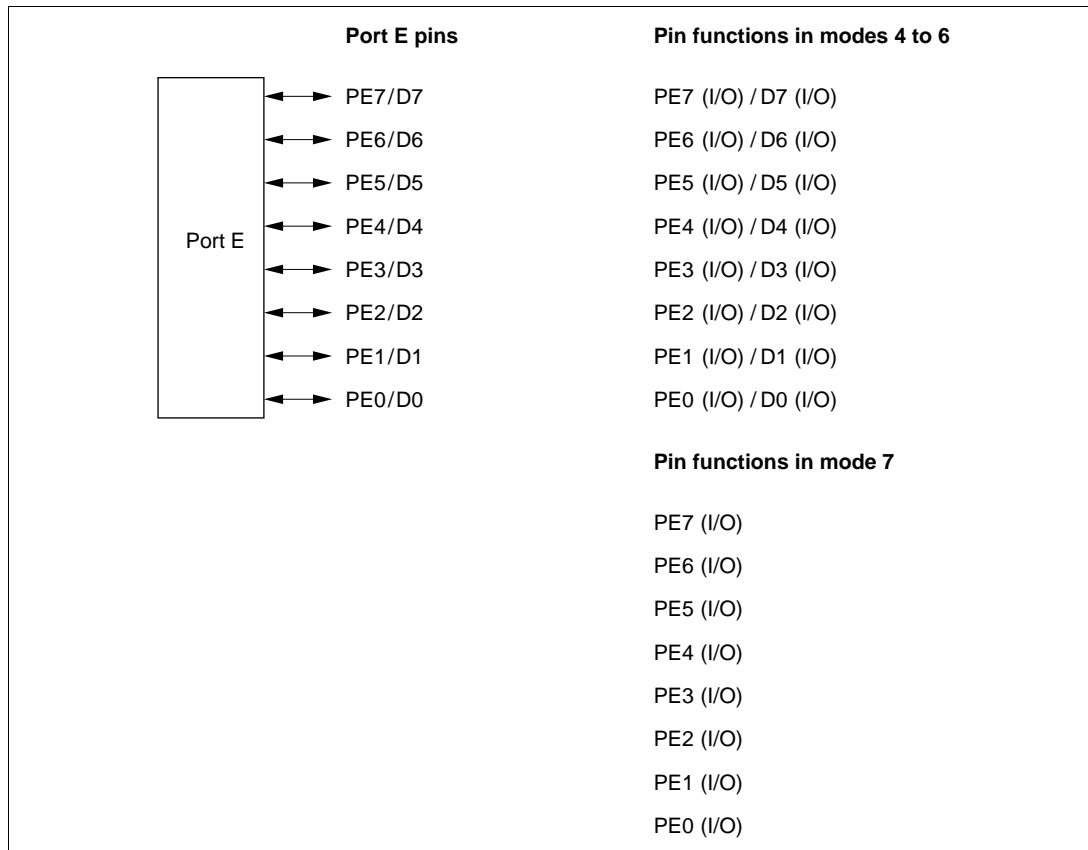


Figure 10B-19 Port E Pin Functions

### 10B.11.2 Register Configuration

Table 10B-18 shows the port E register configuration.

**Table 10B-18 Port E Registers**

Name	Abbreviation	R/W	Initial Value	Address*
Port E data direction register	PEDDR	W	H'00	H'FE3D
Port E data register	PEDR	R/W	H'00	H'FF0D
Port E register	PORTE	R	Undefined	H'FFBD
Port E MOS pull-up control register	PEPCR	R/W	H'00	H'FE44

Note: \* Lower 16 bits of the address.

#### Port E Data Direction Register (PEDDR)

Bit	:	7	6	5	4	3	2	1	0
		PE7DDR	PE6DDR	PE5DDR	PE4DDR	PE3DDR	PE2DDR	PE1DDR	PE0DDR
Initial value :		0	0	0	0	0	0	0	0
R/W	:	W	W	W	W	W	W	W	W

PEDDR is an 8-bit write-only register, the individual bits of which specify input or output for the pins of port E. PEDDR cannot be read; if it is, an undefined value will be read.

PEDDR is initialized to H'00 by a power-on reset, and in hardware standby mode. It retains its prior state by a manual reset or in software standby mode.

- Modes 4 to 6

When 8-bit bus mode has been selected, port E pins function as I/O ports. Setting a PEDDR bit to 1 makes the corresponding port E pin an output port, while clearing the bit to 0 makes the pin an input port.

When 16-bit bus mode has been selected, the input/output direction specification by PEDDR is ignored, and port E is designated for data I/O.

For details of 8-bit and 16-bit bus modes, see section 7, Bus Controller.

- Mode 7

Setting a PEDDR bit to 1 makes the corresponding port E pin an output port, while clearing the bit to 0 makes the pin an input port.

### Port E Data Register (PEDR)

Bit	:	7	6	5	4	3	2	1	0
		PE7DR	PE6DR	PE5DR	PE4DR	PE3DR	PE2DR	PE1DR	PE0DR
Initial value :		0	0	0	0	0	0	0	0
R/W	:	R/W	R/W	R/W	R/W	R/W	R/W	R/W	R/W

PEDR is an 8-bit readable/writable register that stores output data for the port E pins (PE7 to PE0).

PEDR is initialized to H'00 by a power-on reset, and in hardware standby mode. It retains its prior state by a manual reset or in software standby mode.

### Port E Register (PORTE)

Bit	:	7	6	5	4	3	2	1	0
		PE7	PE6	PE5	PE4	PE3	PE2	PE1	PE0
Initial value :		—*	—*	—*	—*	—*	—*	—*	—*
R/W	:	R	R	R	R	R	R	R	R

Note: \* Determined by state of pins PE7 to PE0.

PORTE is an 8-bit read-only register that shows the pin states. It cannot be written to. Writing of output data for the port E pins (PE7 to PE0) must always be performed on PEDR.

If a port E read is performed while PEDDR bits are set to 1, the PEDR values are read. If a port E read is performed while PEDDR bits are cleared to 0, the pin states are read.

After a power-on reset and in hardware standby mode, PORTE contents are determined by the pin states, as PEDDR and PEDR are initialized. PORTE retains its prior state by a manual reset or in software standby mode.



### Port E MOS Pull-Up Control Register (PEPCR)

Bit	:	7	6	5	4	3	2	1	0
		PE7PCR	PE6PCR	PE5PCR	PE4PCR	PE3PCR	PE2PCR	PE1PCR	PE0PCR
Initial value :		0	0	0	0	0	0	0	0
R/W	:	R/W	R/W	R/W	R/W	R/W	R/W	R/W	R/W

PEPCR is an 8-bit readable/writable register that controls the MOS input pull-up function incorporated into port E on an individual bit basis.

When a PEDDR bit is cleared to 0 (input port setting) with 8-bit bus mode selected in modes 4, 5, or 6, or in mode 7, setting the corresponding PEPCR bit to 1 turns on the MOS input pull-up for the corresponding pin.

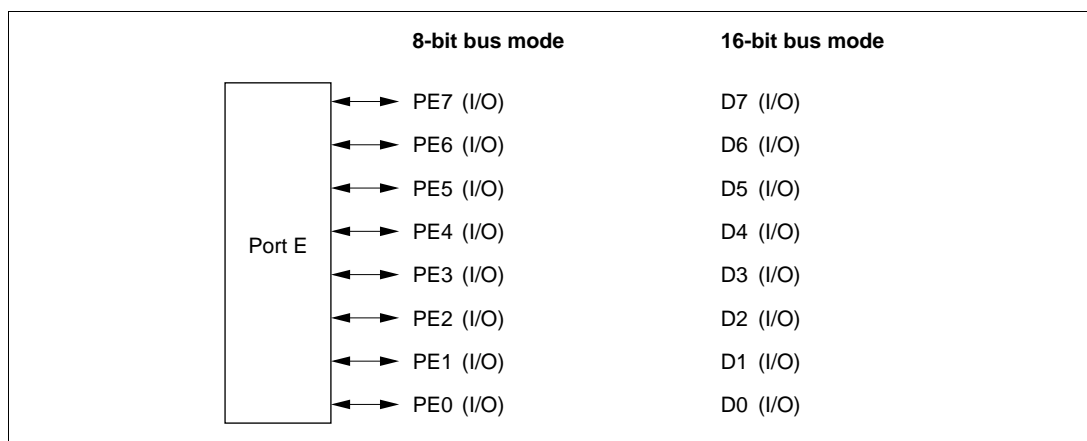
PEPCR is initialized to H'00 by a power-on reset, and in hardware standby mode. It retains its prior state by a manual reset or in software standby mode.

#### 10B.11.3 Pin Functions

**Modes 4 to 6:** In modes 4 to 6, when 8-bit access is designated and 8-bit bus mode is selected, port E pins are automatically designated as I/O ports. Setting a PEDDR bit to 1 makes the corresponding port E pin an output port, while clearing the bit to 0 makes the pin an input port.

When 16-bit bus mode is selected, the input/output direction specification by PEDDR is ignored, and port E is designated for data I/O.

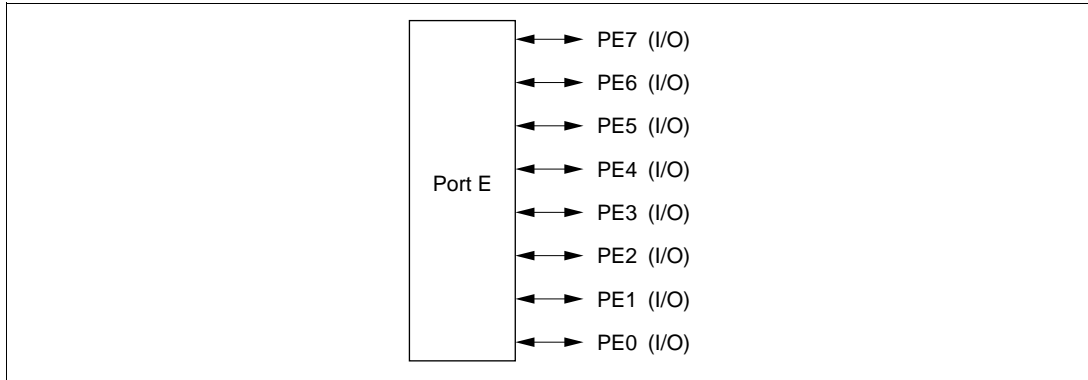
Port E pin functions in modes 4 to 6 are shown in figure 10B-20.



**Figure 10B-20 Port E Pin Functions (Modes 4 to 6)**

**Mode 7:** In mode 7, port E pins function as I/O ports. Input or output can be specified for each pin on a bit-by-bit basis. Setting a PEDDR bit to 1 makes the corresponding port E pin an output port, while clearing the bit to 0 makes the pin an input port.

Port E pin functions in mode 7 are shown in figure 10B-21.



**Figure 10B-21 Port E Pin Functions (Mode 7)**

#### 10B.11.4 MOS Input Pull-Up Function

Port E has a built-in MOS input pull-up function that can be controlled by software. This MOS input pull-up function can be used in modes 4 to 6 when 8-bit bus mode is selected, or in mode 7, and can be specified as on or off on an individual bit basis.

When a PEDDR bit is cleared to 0 in modes 4 to 6 when 8-bit bus mode is selected, or in mode 7, setting the corresponding PEPCR bit to 1 turns on the MOS input pull-up for that pin.

The MOS input pull-up function is in the off state after a power-on reset, and in hardware standby mode. The prior state is retained by a manual reset or in software standby mode.

Table 10B-19 summarizes the MOS input pull-up states.

**Table 10B-19 MOS Input Pull-Up States (Port E)**

Modes	Power-On Reset	Hardware Standby Mode	Manual Reset	Software Standby Mode	In Other Operations
7	OFF	OFF	ON/OFF	ON/OFF	ON/OFF
4 to 6	8-bit bus				
	16-bit bus		OFF	OFF	OFF

**Legend:**

OFF : MOS input pull-up is always off.

ON/OFF : On when PEDDR = 0 and PEPCR = 1; otherwise off.

## 10B.12 Port F

### 10B.12.1 Overview

Port F is an 8-bit I/O port. Port F pins also function as external interrupt input pins ( $\overline{\text{IRQ2}}$  and  $\overline{\text{IRQ3}}$ ), A/D trigger input pin ( $\overline{\text{ADTRG}}$ ), bus control signal input/output pins ( $\overline{\text{AS}}$ ,  $\overline{\text{RD}}$ ,  $\overline{\text{HWR}}$ ,  $\overline{\text{LWR}}$ ,  $\overline{\text{WAIT}}$ ,  $\overline{\text{BREQO}}$ ,  $\overline{\text{BREQ}}$ , and  $\overline{\text{BACK}}$ ), and the system clock ( $\emptyset$ ) output pin.

Figure 10B-22 shows the port F pin configuration.

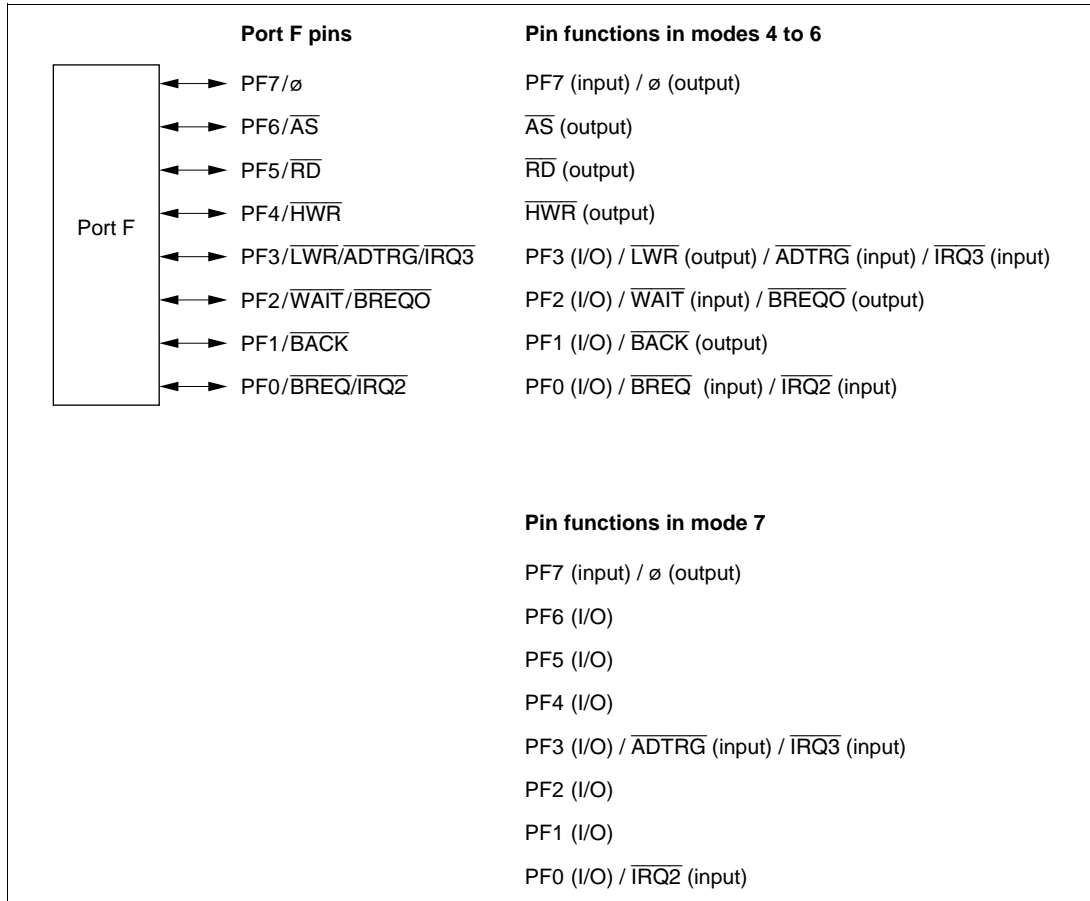


Figure 10B-22 Port F Pin Functions

## 10B.12.2 Register Configuration

Table 10B-20 shows the port F register configuration.

**Table 10B-20 Port F Registers**

Name	Abbreviation	R/W	Initial Value	Address* <sup>1</sup>
Port F data direction register	PFDDR	W	H'80/H'00* <sup>2</sup>	H'FE3E
Port F data register	PFDR	R/W	H'00	H'FF0E
Port F register	PORTF	R	Undefined	H'FFBE

Notes: \*1 Lower 16 bits of the address.

\*2 Initial value depends on the mode.

### Port F Data Direction Register (PFDDR)

Bit	:	7	6	5	4	3	2	1	0
		PF7DDR	PF6DDR	PF5DDR	PF4DDR	PF3DDR	PF2DDR	PF1DDR	PF0DDR
Modes 4 to 6									
Initial value :		1	0	0	0	0	0	0	0
R/W :		W	W	W	W	W	W	W	W
Mode 7									
Initial value :		0	0	0	0	0	0	0	0
R/W :		W	W	W	W	W	W	W	W

PFDDR is an 8-bit write-only register, the individual bits of which specify input or output for the pins of port F. PFDDR cannot be read; if it is, an undefined value will be read.

PFDDR is initialized by a power-on reset, and in hardware standby mode, to H'80 in modes 4 to 6, and to H'00 in mode 7. It retains its prior state by a manual reset or in software standby mode. The OPE bit in SBYCR is used to select whether the bus control output pins retain their output state or become high-impedance when a transition is made to software standby mode.

- Modes 4 to 6

Pin PF7 functions as the  $\emptyset$  output pin when the corresponding PFDDR bit is set to 1, and as an input port when the bit is cleared to 0.

The input/output direction specified by PFDDR is ignored for pins PF6 to PF3, which are automatically designated as bus control outputs ( $\overline{AS}$ ,  $\overline{RD}$ ,  $\overline{HWR}$ , and  $\overline{LWR}$ ).

Pins PF2 to PF0 are designated as bus control input/output pins ( $\overline{WAIT}$ ,  $\overline{BREQO}$ ,  $\overline{BACK}$ , and  $\overline{BREQ}$ ) by means of bus controller settings. At other times, setting a PFDDR bit to 1 makes the corresponding port F pin an output port, while clearing the bit to 0 makes the pin an input port.

- Mode 7

Setting a PFDDR bit to 1 makes the corresponding port F pin PF6 to PF0 an output port, or in the case of pin PF7, the  $\phi$  output pin. Clearing the bit to 0 makes the pin an input port.

**Port F Data Register (PFDR)**

Bit	:	7	6	5	4	3	2	1	0
		PF7DR	PF6DR	PF5DR	PF4DR	PF3DR	PF2DR	PF1DR	PF0DR
Initial value :		0	0	0	0	0	0	0	0
R/W	:	R/W	R/W	R/W	R/W	R/W	R/W	R/W	R/W

PFDR is an 8-bit readable/writable register that stores output data for the port F pins (PF7 to PF0).

PFDR is initialized to H'00 by a power-on reset, and in hardware standby mode. It retains its prior state by a manual reset or in software standby mode.

**Port F Register (PORTF)**

Bit	:	7	6	5	4	3	2	1	0
		PF7	PF6	PF5	PF4	PF3	PF2	PF1	PF0
Initial value :		—*	—*	—*	—*	—*	—*	—*	—*
R/W	:	R	R	R	R	R	R	R	R

Note: \* Determined by state of pins PF7 to PF0.

PORTF is an 8-bit read-only register that shows the pin states. It cannot be written to. Writing of output data for the port F pins (PF7 to PF0) must always be performed on PFDR.

If a port F read is performed while PFDDR bits are set to 1, the PFDR values are read. If a port F read is performed while PFDDR bits are cleared to 0, the pin states are read.

After a power-on reset and in hardware standby mode, PORTF contents are determined by the pin states, as PFDDR and PFDR are initialized. PORTF retains its prior state by a manual reset or in software standby mode.

### 10B.12.3 Pin Functions

Port F pins also function as external interrupt input pins ( $\overline{\text{IRQ2}}$  and  $\overline{\text{IRQ3}}$ ), A/D trigger input pin ( $\overline{\text{ADTRG}}$ ), bus control signal input/output pins ( $\overline{\text{AS}}$ ,  $\overline{\text{RD}}$ ,  $\overline{\text{HWR}}$ ,  $\overline{\text{LWR}}$ ,  $\overline{\text{WAIT}}$ ,  $\overline{\text{BREQO}}$ ,  $\overline{\text{BREQ}}$ , and  $\overline{\text{BACK}}$ ), and the system clock ( $\emptyset$ ) output pin. The pin functions differ between modes 4 to 6, and mode 7. Port F pin functions are shown in table 10B-21.

**Table 10B-21 Port F Pin Functions**

Pin	Selection Method and Pin Functions			
PF7/ $\emptyset$	The pin function is switched as shown below according to bit PF7DDR.			
	PF7DDR	0	1	
	Pin function	PF7 input pin	$\emptyset$ output pin	
PF6/ $\overline{\text{AS}}$	The pin function is switched as shown below according to the combination of the operating mode and bits BREQOE, WAITE, ABW5 to ABW2, and PF2DDR.			
	Operating Mode	Modes 4 to 6	Mode 7	
	PF6DDR	—	0	1
	Pin function	$\overline{\text{AS}}$ output pin	PF6 input pin	PF6 output pin
PF5/ $\overline{\text{RD}}$	The pin function is switched as shown below according to the operating mode and bit PF5DDR.			
	Operating Mode	Modes 4 to 6	Mode 7	
	PF5DDR	—	0	1
	Pin function	$\overline{\text{RD}}$ output pin	PF5 input pin	PF5 output pin
PF4/ $\overline{\text{HWR}}$	The pin function is switched as shown below according to the operating mode and bit PF4DDR.			
	Operating Mode	Modes 4 to 6	Mode 7	
	PF4DDR	—	0	1
	Pin function	$\overline{\text{HWR}}$ output pin	PF4 input pin	PF4 output pin

**Pin Selection Method and Pin Functions**

**PF3/ $\overline{\text{LWR}}$ / $\overline{\text{ADTRG}}$ / $\overline{\text{IRQ3}}$**  The pin function is switched as shown below according to the operating mode, the bus mode, A/D converter bits TRGS1 and TRGS0, and bit PF3DDR.

Operating mode	Modes 4 to 6			Mode 7	
Bus mode	16-bit bus mode	8-bit bus mode		—	
PF3DDR	—	0	1	0	1
Pin function	$\overline{\text{LWR}}$ output pin	PF3 input pin	PF3 output pin	PF3 input pin	PF3 output pin
		$\overline{\text{ADTRG}}$ input pin* <sup>1</sup>			
		$\overline{\text{IRQ3}}$ input pin* <sup>2</sup>			

Notes: \*1  $\overline{\text{ADTRG}}$  input when TRGS0 = TRGS1 = 1.

\*2 When used as an external interrupt input pin, do not use as an I/O pin for another function.

**PF2/ $\overline{\text{WAIT}}$ / $\overline{\text{BREQO}}$**

The pin function is switched as shown below according to the combination of the operating mode and bits BREQOE, WAITE, ABW5 to ABW2, and PF2DDR.

Operating Mode	Modes 4 to 6				Mode 7	
BREQOE	0		1		—	
WAITE	0		1		—	
PF2DDR	0	1	—	—	0	1
Pin function	PF2 input pin	PF2 output pin	$\overline{\text{WAIT}}$ input pin	$\overline{\text{BREQO}}$ output pin	PF2 input pin	PF2 output pin

**PF1/ $\overline{\text{BACK}}$**

The pin function is switched as shown below according to the combination of the operating mode and bits BRLE and PF1DDR.

Operating Mode	Modes 4 to 6			Mode 7		
BRLE	0		1		—	
PF1DDR	0	1	—		0	1
Pin function	PF1 input pin	PF1 output pin	$\overline{\text{BACK}}$ output pin	PF1 input pin	PF1 output pin	

**Pin Selection Method and Pin Functions**

PF0/ $\overline{\text{BREQ}}$ / $\overline{\text{IRQ2}}$  The pin function is switched as shown below according to the combination of the operating mode, and bits BRLE and PF0DDR.

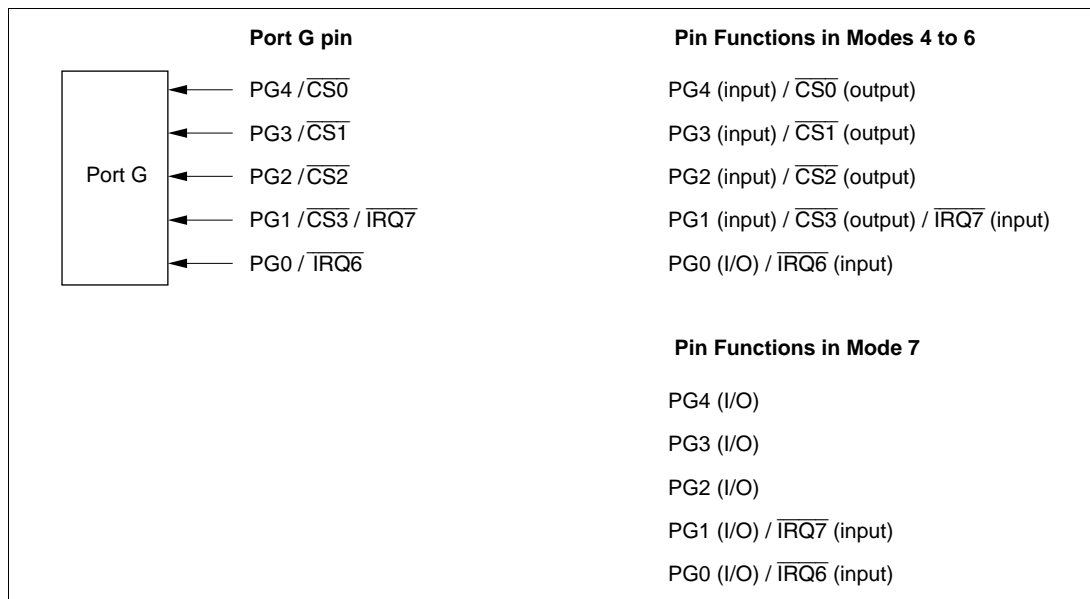
Operating Mode	Modes 4 to 6			Mode 7	
	0		1	—	
BRLE	0		1	—	
PF0DDR	0	1	—	0	1
Pin function	PF0 input pin	PF0 output pin	$\overline{\text{BREQ}}$ input pin	PF0 input pin	PF0 output pin
	$\overline{\text{IRQ2}}$ input pin				

**10B.13 Port G**

**10B.13.1 Overview**

Port G is a 5-bit I/O port and also used as external interrupt input pins ( $\overline{\text{IRQ6}}$  and  $\overline{\text{IRQ7}}$ ) and bus control signal output pins ( $\overline{\text{CS0}}$  to  $\overline{\text{CS3}}$ ).

Figure 10B-23 shows the configuration of port G pins.



**Figure 10B-23 Port G Pin Functions**



### 10B.13.2 Register Configuration

Table 10B-22 shows the port G register configuration.

**Table 10B-22 Port G Registers**

Name	Abbreviation	R/W	Initial Value* <sup>2</sup>	Address* <sup>1</sup>
Port G data direction register	PGDDR	W	H'10/H'00* <sup>3</sup>	H'FE3F
Port G data register	PGDR	R/W	H'00	H'FF0F
Port G register	PORTG	R	Undefined	H'FFBF

Notes: \*1 Lower 16 bits of the address.

\*2 Value of bits 4 to 0.

\*3 The initial value varies according to the mode.

#### Port G Data Direction Register (PGDDR)

Bit	7	6	5	4	3	2	1	0
	—	—	—	PG4DDR	PG3DDR	PG2DDR	PG1DDR	PG0DDR
Modes 4 and 5								
Initial value	Undefined	Undefined	Undefined	1	0	0	0	0
R/W	—	—	—	W	W	W	W	W
Modes 6 and 7								
Initial value	Undefined	Undefined	Undefined	0	0	0	0	0
R/W	—	—	—	W	W	W	W	W

PGDDR is an 8-bit write only register and specifies I/O of each pin of port G in bit units. Read processing is invalid. Bits 7 to 5 are reserved bits. When the contents are read, undefined values are read.

In modes 4 and 5, the PG4DDR bits are initialized to H'10 (bits 4 to 0) in power-on reset or hardware standby mode, in modes 6 and 7, the bits are initialized to H'00 (bits 4 to 0). In manual reset or software standby mode, PGDDR retains the last status. Use the OPE bit of SBYCR to select whether the bus control output pin retains the output state or becomes the high-impedance when the mode is changed to a software standby mode.

- Modes 4 to 6

When PGDDR is set to 1, pins PG4 to PG1 function as bus control signal output pins ( $\overline{CS0}$  to  $\overline{CS3}$ ). When PGDDR is cleared to 0, the pins function as input ports.

When PGDDR is set to 1, the PG0 pin functions as an output port, and when PGDDR is cleared to 0, it functions as an input port.

- Mode 7

PGDDR to 1 it becomes an output port, and by clearing it to 0 it becomes an input port.

### Port G Data Register (PGDR)

Bit	:	7	6	5	4	3	2	1	0
		—	—	—	PG4DR	PG3DR	PG2DR	PG1DR	PG0DR
Initial value	:	Undefined	Undefined	Undefined	0	0	0	0	0
R/W	:	—	—	—	R/W	R/W	R/W	R/W	R/W

PGDR is an 8-bit read/write register and stores output data of port G output pins (PG4 to PG0).

Bits 7 to 5 are reserved bits. When the contents are read, undefined values are read. Write processing is invalid.

In power-on reset or hardware standby mode, PGDR is initialized to H'00 (bits 4 to 0). In manual reset or software standby mode, PGDR retains the last state.

### (3) Port G Register (PORTG)

Bit	:	7	6	5	4	3	2	1	0
		—	—	—	PG4	PG3	PG2	PG1	PG0
Initial value	:	Undefined	Undefined	Undefined	—*	—*	—*	—*	—*
R/W	:	—	—	—	R	R	R	R	R

Note: \* Determined by the state of PG4 to PG0

PORTG is an 8-bit read only register and reflects the pin state. Write processing is invalid. Write processing of output data of port G pins (PG4 to PG0) must be performed for PGDR.

Bits 7 to 5 are reserved bits. When the contents are read, undefined values are read. Write processing is invalid.

If port G is read when PGDDR is set to 1, the value in PGDR is read. If port G is read when PGDDR is cleared to 0, the pin state is read.

In power-on reset or hardware standby mode, port G is determined by the pin state because PGDDR and PGDR are initialized. In manual reset or software standby mode, the last state is retained.

### 10B.13.3 Pin Functions

Port G is used also as external interrupt input pins ( $\overline{\text{IRQ6}}$  and  $\overline{\text{IRQ7}}$ ) and bus control signal output pins ( $\overline{\text{CS0}}$  to  $\overline{\text{CS3}}$ ). The pin functions are different between modes 4 and 6, and mode 7. Table 10B-23 shows the port G pin functions.

**Table 10B-23 Port G Pin Functions**

Pin	Selection Method and Pin Functions				
PG4/ $\overline{\text{CS0}}$	The pin function is switched as shown below according to the operating mode and bit PG4DDR.				
	Operating Mode	Modes 4 to 6		Mode 7	
	PG4DDR	0	1	0	1
	Pin function	PG4 input pin	$\overline{\text{CS0}}$ output pin	PG4 input pin	PG4 output pin
PG3/ $\overline{\text{CS1}}$	The pin function is switched as shown below according to the operating mode and bit PG3DDR.				
	Operating Mode	Modes 4 to 6		Mode 7	
	PG3DDR	0	1	0	1
	Pin function	PG3 input pin	$\overline{\text{CS1}}$ output pin	PG3 input pin	PG3 output pin
PG2/ $\overline{\text{CS2}}$	The pin function is switched as shown below according to the operating mode and bit PG2DDR.				
	Operating Mode	Modes 4 to 6		Mode 7	
	PG2DDR	0	1	0	1
	Pin function	PG2 input pin	$\overline{\text{CS2}}$ output pin	PG2 input pin	PG2 output pin

**Pin Selection Method and Pin Functions**

**PG1/ $\overline{\text{CS3}}$ / $\overline{\text{IRQ7}}$**  The pin function is switched as shown below according to the operating mode and bits OES and PG1DDR in BCRL.

Operating Mode	Modes 4 to 6		Mode 7	
PG1DDR	0	1	0	1
Pin function	PG1 input pin	$\overline{\text{CS3}}$ output pin	PG1 input pin	PG1 output pin
	$\overline{\text{IRQ7}}$ input			

**PG0/ $\overline{\text{IRQ6}}$**  The pin function is switched as shown below according to the operating mode and bits RMTS2 to RMTS0 in BCRH.

Operating Mode	Modes 4 to 6		Mode 7	
PG0DDR	0	1	0	1
Pin function	PG0 input pin	PG0 output pin	PG0 input pin	PG0 output pin
	$\overline{\text{IRQ6}}$ input			

## Section 11 16-Bit Timer Pulse Unit (TPU)

### 11.1 Overview

The H8S/2633 Series has an on-chip 16-bit timer pulse unit (TPU) that comprises six 16-bit timer channels.

#### 11.1.1 Features

- Maximum 16-pulse input/output
  - A total of 16 timer general registers (TGRs) are provided (four each for channels 0 and 3, and two each for channels 1, 2, 4, and 5), each of which can be set independently as an output compare/input capture register
  - TGRC and TGRD for channels 0 and 3 can also be used as buffer registers
- Selection of 8 counter input clocks for each channel
- The following operations can be set for each channel:
  - Waveform output at compare match: Selection of 0, 1, or toggle output
  - Input capture function: Selection of rising edge, falling edge, or both edge detection
  - Counter clear operation: Counter clearing possible by compare match or input capture
  - Synchronous operation: Multiple timer counters (TCNT) can be written to simultaneously
  - Simultaneous clearing by compare match and input capture possible
  - Register simultaneous input/output possible by counter synchronous operation
  - PWM mode: Any PWM output duty can be set
  - Maximum of 15-phase PWM output possible by combination with synchronous operation
- Buffer operation settable for channels 0 and 3
  - Input capture register double-buffering possible
  - Automatic rewriting of output compare register possible
- Phase counting mode settable independently for each of channels 1, 2, 4, and 5
  - Two-phase encoder pulse up/down-count possible
- Cascaded operation
  - Channel 2 (channel 5) input clock operates as 32-bit counter by setting channel 1 (channel 4) overflow/underflow
- Fast access via internal 16-bit bus
  - Fast access is possible via a 16-bit bus interface

- 26 interrupt sources
  - For channels 0 and 3, four compare match/input capture dual-function interrupts and one overflow interrupt can be requested independently
  - For channels 1, 2, 4, and 5, two compare match/input capture dual-function interrupts, one overflow interrupt, and one underflow interrupt can be requested independently
- Automatic transfer of register data
  - Block transfer, 1-word data transfer, and 1-byte data transfer possible by data transfer controller (DTC)\* or DMA controller (DMAC)\*
- Programmable pulse generator (PPG)\* output trigger can be generated
  - Channels 0 to 3 compare match/input capture signals can be used as PPG output trigger
- A/D converter conversion start trigger can be generated
  - Channels 0 to 5 compare match A/input capture A signals can be used as A/D converter conversion start trigger
- Module stop mode can be set
  - As the initial setting, TPU operation is halted. Register access is enabled by exiting module stop mode

Table 11-1 lists the functions of the TPU.

Note: \* This function is not available in the H8S/2695.

**Table 11-1 TPU Functions**

Item	Channel 0	Channel 1	Channel 2	Channel 3	Channel 4	Channel 5
Count clock	ø/1	ø/1	ø/1	ø/1	ø/1	ø/1
	ø/4	ø/4	ø/4	ø/4	ø/4	ø/4
	ø/16	ø/16	ø/16	ø/16	ø/16	ø/16
	ø/64	ø/64	ø/64	ø/64	ø/64	ø/64
	TCLKA	ø/256	ø/1024	ø/256	ø/1024	ø/256
	TCLKB	TCLKA	TCLKA	ø/1024	TCLKA	TCLKA
	TCLKC	TCLKB	TCLKB	ø/4096	TCLKC	TCLKC
	TCLKD		TCLKC	TCLKA		TCLKD
General registers	TGR0A	TGR1A	TGR2A	TGR3A	TGR4A	TGR5A
	TGR0B	TGR1B	TGR2B	TGR3B	TGR4B	TGR5B
General registers/ buffer registers	TGR0C	—	—	TGR3C	—	—
	TGR0D			TGR3D		
I/O pins	TIOCA0	TIOCA1	TIOCA2	TIOCA3	TIOCA4	TIOCA5
	TIOCB0	TIOCB1	TIOCB2	TIOCB3	TIOCB4	TIOCB5
	TIOCC0			TIOCC3		
	TIOCD0			TIOCD3		
Counter clear function	TGR compare match or input capture	TGR compare match or input capture	TGR compare match or input capture	TGR compare match or input capture	TGR compare match or input capture	TGR compare match or input capture
Compare match output	0 output	○	○	○	○	○
	1 output	○	○	○	○	○
	Toggle output	○	○	○	○	○
Input capture function	○	○	○	○	○	○
Synchronous operation	○	○	○	○	○	○
PWM mode	○	○	○	○	○	○
Phase counting mode	—	○	○	—	○	○
Buffer operation	○	—	—	○	—	—

Item	Channel 0	Channel 1	Channel 2	Channel 3	Channel 4	Channel 5
DMAC activation*	TGR0A compare match or input capture	TGR1A compare match or input capture	TGR2A compare match or input capture	TGR3A compare match or input capture	TGR4A compare match or input capture	TGR5A compare match or input capture
DTC activation*	TGR compare match or input capture	TGR compare match or input capture	TGR compare match or input capture	TGR compare match or input capture	TGR compare match or input capture	TGR compare match or input capture
A/D converter trigger	TGR0A compare match or input capture	TGR1A compare match or input capture	TGR2A compare match or input capture	TGR3A compare match or input capture	TGR4A compare match or input capture	TGR5A compare match or input capture
PPG trigger*	TGR0A/ TGR0B compare match or input capture	TGR1A/ TGR1B compare match or input capture	TGR2A/ TGR2B compare match or input capture	TGR3A/ TGR3B compare match or input capture	—	—
Interrupt sources	5 sources <ul style="list-style-type: none"> <li>• Compare match or input capture 0A</li> <li>• Compare match or input capture 0B</li> <li>• Compare match or input capture 0C</li> <li>• Compare match or input capture 0D</li> <li>• Overflow</li> </ul>	4 sources <ul style="list-style-type: none"> <li>• Compare match or input capture 1A</li> <li>• Compare match or input capture 1B</li> <li>• Overflow</li> <li>• Underflow</li> </ul>	4 sources <ul style="list-style-type: none"> <li>• Compare match or input capture 2A</li> <li>• Compare match or input capture 2B</li> <li>• Overflow</li> <li>• Underflow</li> </ul>	5 sources <ul style="list-style-type: none"> <li>• Compare match or input capture 3A</li> <li>• Compare match or input capture 3B</li> <li>• Compare match or input capture 3C</li> <li>• Compare match or input capture 3D</li> <li>• Overflow</li> </ul>	4 sources <ul style="list-style-type: none"> <li>• Compare match or input capture 4A</li> <li>• Compare match or input capture 4B</li> <li>• Overflow</li> <li>• Underflow</li> </ul>	4 sources <ul style="list-style-type: none"> <li>• Compare match or input capture 5A</li> <li>• Compare match or input capture 5B</li> <li>• Overflow</li> <li>• Underflow</li> </ul>

Legend

○ : Possible

— : Not possible

Note: \* This function is not available in the H8S/2695.



## 11.1.2 Block Diagram

Figure 11-1 shows a block diagram of the TPU.

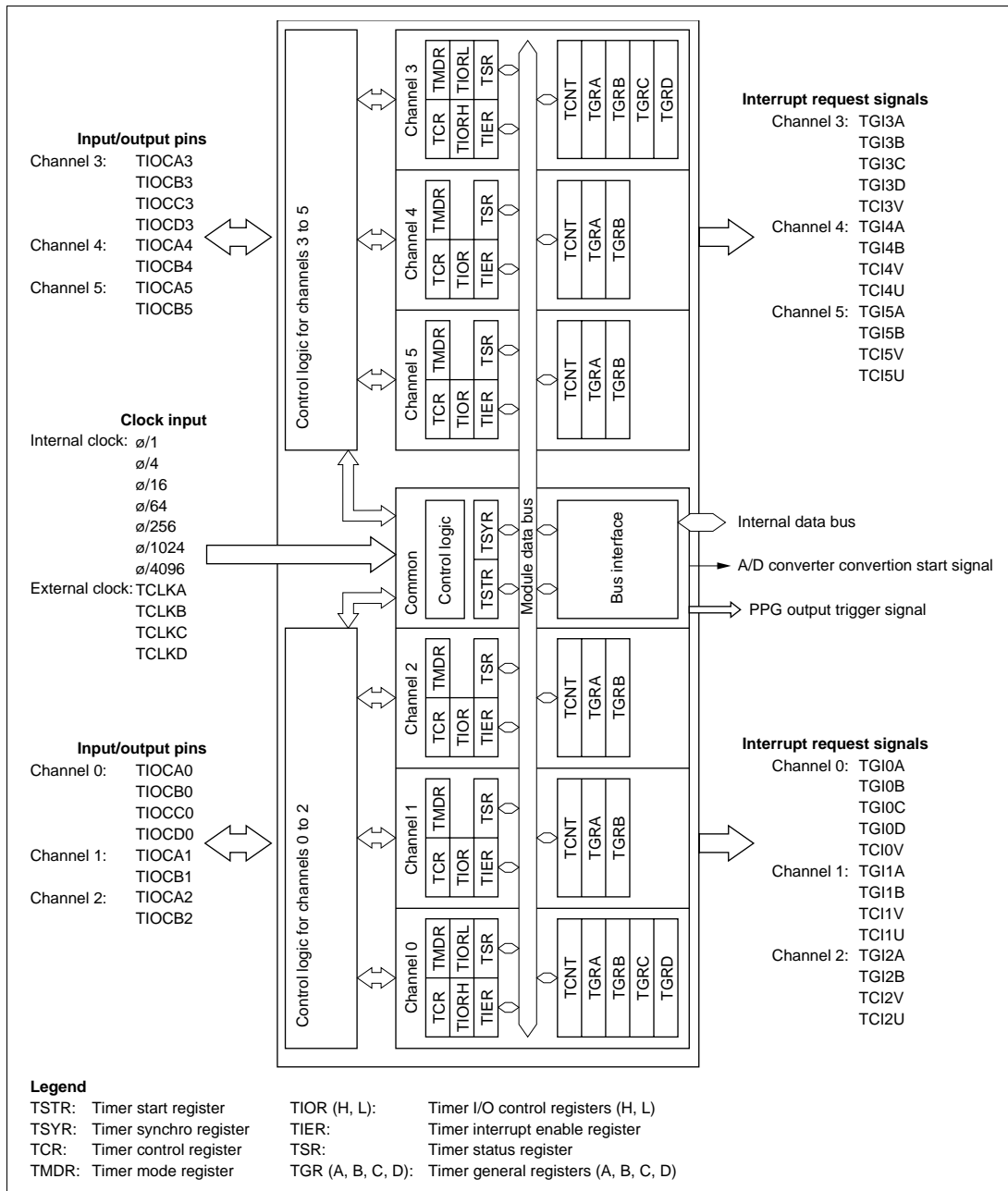


Figure 11-1 Block Diagram of TPU

### 11.1.3 Pin Configuration

Table 11-2 summarizes the TPU pins.

**Table 11-2 TPU Pins**

Channel	Name	Symbol	I/O	Function
All	Clock input A	TCLKA	Input	External clock A input pin (Channel 1 and 5 phase counting mode A phase input)
	Clock input B	TCLKB	Input	External clock B input pin (Channel 1 and 5 phase counting mode B phase input)
	Clock input C	TCLKC	Input	External clock C input pin (Channel 2 and 4 phase counting mode A phase input)
	Clock input D	TCLKD	Input	External clock D input pin (Channel 2 and 4 phase counting mode B phase input)
0	Input capture/out compare match A0	TIOCA0	I/O	TGR0A input capture input/output compare output/PWM output pin
	Input capture/out compare match B0	TIOCB0	I/O	TGR0B input capture input/output compare output/PWM output pin
	Input capture/out compare match C0	TIOCC0	I/O	TGR0C input capture input/output compare output/PWM output pin
	Input capture/out compare match D0	TIOCD0	I/O	TGR0D input capture input/output compare output/PWM output pin
1	Input capture/out compare match A1	TIOCA1	I/O	TGR1A input capture input/output compare output/PWM output pin
	Input capture/out compare match B1	TIOCB1	I/O	TGR1B input capture input/output compare output/PWM output pin
2	Input capture/out compare match A2	TIOCA2	I/O	TGR2A input capture input/output compare output/PWM output pin
	Input capture/out compare match B2	TIOCB2	I/O	TGR2B input capture input/output compare output/PWM output pin

Channel	Name	Symbol	I/O	Function
3	Input capture/out compare match A3	TIOCA3	I/O	TGR3A input capture input/output compare output/PWM output pin
	Input capture/out compare match B3	TIOCB3	I/O	TGR3B input capture input/output compare output/PWM output pin
	Input capture/out compare match C3	TIOCC3	I/O	TGR3C input capture input/output compare output/PWM output pin
	Input capture/out compare match D3	TIOCD3	I/O	TGR3D input capture input/output compare output/PWM output pin
4	Input capture/out compare match A4	TIOCA4	I/O	TGR4A input capture input/output compare output/PWM output pin
	Input capture/out compare match B4	TIOCB4	I/O	TGR4B input capture input/output compare output/PWM output pin
5	Input capture/out compare match A5	TIOCA5	I/O	TGR5A input capture input/output compare output/PWM output pin
	Input capture/out compare match B5	TIOCB5	I/O	TGR5B input capture input/output compare output/PWM output pin

### 11.1.4 Register Configuration

Table 11-3 summarizes the TPU registers.

**Table 11-3 TPU Registers**

Channel	Name	Abbreviation	R/W	Initial Value	Address <sup>*1</sup>
0	Timer control register 0	TCR0	R/W	H'00	H'FF10
	Timer mode register 0	TMDR0	R/W	H'C0	H'FF11
	Timer I/O control register 0H	TIOR0H	R/W	H'00	H'FF12
	Timer I/O control register 0L	TIOR0L	R/W	H'00	H'FF13
	Timer interrupt enable register 0	TIER0	R/W	H'40	H'FF14
	Timer status register 0	TSR0	R/(W) <sup>*2</sup>	H'C0	H'FF15
	Timer counter 0	TCNT0	R/W	H'0000	H'FF16
	Timer general register 0A	TGR0A	R/W	H'FFFF	H'FF18
	Timer general register 0B	TGR0B	R/W	H'FFFF	H'FF1A
	Timer general register 0C	TGR0C	R/W	H'FFFF	H'FF1C
	Timer general register 0D	TGR0D	R/W	H'FFFF	H'FF1E
1	Timer control register 1	TCR1	R/W	H'00	H'FF20
	Timer mode register 1	TMDR1	R/W	H'C0	H'FF21
	Timer I/O control register 1	TIOR1	R/W	H'00	H'FF22
	Timer interrupt enable register 1	TIER1	R/W	H'40	H'FF24
	Timer status register 1	TSR1	R/(W) <sup>*2</sup>	H'C0	H'FF25
	Timer counter 1	TCNT1	R/W	H'0000	H'FF26
	Timer general register 1A	TGR1A	R/W	H'FFFF	H'FF28
	Timer general register 1B	TGR1B	R/W	H'FFFF	H'FF2A
2	Timer control register 2	TCR2	R/W	H'00	H'FF30
	Timer mode register 2	TMDR2	R/W	H'C0	H'FF31
	Timer I/O control register 2	TIOR2	R/W	H'00	H'FF32
	Timer interrupt enable register 2	TIER2	R/W	H'40	H'FF34
	Timer status register 2	TSR2	R/(W) <sup>*2</sup>	H'C0	H'FF35
	Timer counter 2	TCNT2	R/W	H'0000	H'FF36
	Timer general register 2A	TGR2A	R/W	H'FFFF	H'FF38
	Timer general register 2B	TGR2B	R/W	H'FFFF	H'FF3A

Channel	Name	Abbreviation	R/W	Initial Value	Address* <sup>1</sup>
3	Timer control register 3	TCR3	R/W	H'00	H'FE80
	Timer mode register 3	TMDR3	R/W	H'C0	H'FE81
	Timer I/O control register 3H	TIOR3H	R/W	H'00	H'FE82
	Timer I/O control register 3L	TIOR3L	R/W	H'00	H'FE83
	Timer interrupt enable register 3	TIER3	R/W	H'40	H'FE84
	Timer status register 3	TSR3	R/(W)* <sup>2</sup>	H'C0	H'FE85
	Timer counter 3	TCNT3	R/W	H'0000	H'FE86
	Timer general register 3A	TGR3A	R/W	H'FFFF	H'FE88
	Timer general register 3B	TGR3B	R/W	H'FFFF	H'FE8A
	Timer general register 3C	TGR3C	R/W	H'FFFF	H'FE8C
	Timer general register 3D	TGR3D	R/W	H'FFFF	H'FE8E
4	Timer control register 4	TCR4	R/W	H'00	H'FE90
	Timer mode register 4	TMDR4	R/W	H'C0	H'FE91
	Timer I/O control register 4	TIOR4	R/W	H'00	H'FE92
	Timer interrupt enable register 4	TIER4	R/W	H'40	H'FE94
	Timer status register 4	TSR4	R/(W) * <sup>2</sup>	H'C0	H'FE95
	Timer counter 4	TCNT4	R/W	H'0000	H'FE96
	Timer general register 4A	TGR4A	R/W	H'FFFF	H'FE98
	Timer general register 4B	TGR4B	R/W	H'FFFF	H'FE9A
5	Timer control register 5	TCR5	R/W	H'00	H'FEA0
	Timer mode register 5	TMDR5	R/W	H'C0	H'FEA1
	Timer I/O control register 5	TIOR5	R/W	H'00	H'FEA2
	Timer interrupt enable register 5	TIER5	R/W	H'40	H'FEA4
	Timer status register 5	TSR5	R/(W) * <sup>2</sup>	H'C0	H'FEA5
	Timer counter 5	TCNT5	R/W	H'0000	H'FEA6
	Timer general register 5A	TGR5A	R/W	H'FFFF	H'FEA8
	Timer general register 5B	TGR5B	R/W	H'FFFF	H'FEAA
All	Timer start register	TSTR	R/W	H'00	H'FEB0
	Timer synchro register	TSYR	R/W	H'00	H'FEB1
	Module stop control register A	MSTPCRA	R/W	H'3F	H'FDE8

Notes: \*1 Lower 16 bits of the address.

\*2 Only 0 can be written, for flag clearing.

## 11.2 Register Descriptions

### 11.2.1 Timer Control Register (TCR)

#### Channel 0: TCR0

#### Channel 3: TCR3

Bit	:	7	6	5	4	3	2	1	0
		CCLR2	CCLR1	CCLR0	CKEG1	CKEG0	TPSC2	TPSC1	TPSC0
Initial value :		0	0	0	0	0	0	0	0
R/W	:	R/W	R/W	R/W	R/W	R/W	R/W	R/W	R/W

#### Channel 1: TCR1

#### Channel 2: TCR2

#### Channel 4: TCR4

#### Channel 5: TCR5

Bit	:	7	6	5	4	3	2	1	0
		—	CCLR1	CCLR0	CKEG1	CKEG0	TPSC2	TPSC1	TPSC0
Initial value :		0	0	0	0	0	0	0	0
R/W	:	—	R/W	R/W	R/W	R/W	R/W	R/W	R/W

The TCR registers are 8-bit registers that control the TCNT channels. The TPU has six TCR registers, one for each of channels 0 to 5. The TCR registers are initialized to H'00 by a reset, and in hardware standby mode.

TCR register settings should be made only when TCNT operation is stopped.

**Bits 7, 6, and 5—Counter Clear 2, 1, and 0 (CCLR2, CCLR1, CCLR0):** These bits select the TCNT counter clearing source.

Channel	Bit 7	Bit 6	Bit 5	Description
	CCLR2	CCLR1	CCLR0	
0, 3	0	0	0	TCNT clearing disabled (Initial value)
			1	TCNT cleared by TGRA compare match/input capture
			1	TCNT cleared by TGRB compare match/input capture
			1	TCNT cleared by counter clearing for another channel performing synchronous clearing/synchronous operation * <sup>1</sup>
1	0	0	0	TCNT clearing disabled
			1	TCNT cleared by TGRC compare match/input capture * <sup>2</sup>
			1	TCNT cleared by TGRD compare match/input capture * <sup>2</sup>
			1	TCNT cleared by counter clearing for another channel performing synchronous clearing/synchronous operation * <sup>1</sup>

Channel	Bit 7	Bit 6	Bit 5	Description
	Reserved* <sup>3</sup>	CCLR1	CCLR0	
1, 2, 4, 5	0	0	0	TCNT clearing disabled (Initial value)
			1	TCNT cleared by TGRA compare match/input capture
			1	TCNT cleared by TGRB compare match/input capture
			1	TCNT cleared by counter clearing for another channel performing synchronous clearing/synchronous operation * <sup>1</sup>

- Notes: \*<sup>1</sup> Synchronous operation setting is performed by setting the SYNC bit in TSYR to 1.  
\*<sup>2</sup> When TGRC or TGRD is used as a buffer register, TCNT is not cleared because the buffer register setting has priority, and compare match/input capture does not occur.  
\*<sup>3</sup> Bit 7 is reserved in channels 1, 2, 4, and 5. It is always read as 0 and cannot be modified.

**Bits 4 and 3—Clock Edge 1 and 0 (CKEG1, CKEG0):** These bits select the input clock edge. When the input clock is counted using both edges, the input clock period is halved (e.g.  $\phi/4$  both edges =  $\phi/2$  rising edge). If phase counting mode is used on channels 1, 2, 4, and 5, this setting is ignored and the phase counting mode setting has priority.

Bit 4	Bit 3	Description
CKEG1	CKEG0	
0	0	Count at rising edge (Initial value)
	1	Count at falling edge
1	—	Count at both edges

Note: Internal clock edge selection is valid when the input clock is  $\phi/4$  or slower. This setting is ignored if the input clock is  $\phi/1$ , or when overflow/underflow of another channel is selected.

**Bits 2, 1, and 0—Time Prescaler 2, 1, and 0 (TPSC2 to TPSC0):** These bits select the TCNT counter clock. The clock source can be selected independently for each channel. Table 11-4 shows the clock sources that can be set for each channel.

**Table 11-4 TPU Clock Sources**

Channel	Internal Clock							External Clock				Overflow/ Underflow on Another Channel
	$\phi/1$	$\phi/4$	$\phi/16$	$\phi/64$	$\phi/256$	$\phi/1024$	$\phi/4096$	TCLKA	TCLKB	TCLKC	TCLKD	
0	<input type="radio"/>	<input type="radio"/>	<input type="radio"/>	<input type="radio"/>				<input type="radio"/>	<input type="radio"/>	<input type="radio"/>	<input type="radio"/>	
1	<input type="radio"/>	<input type="radio"/>	<input type="radio"/>	<input type="radio"/>	<input type="radio"/>			<input type="radio"/>	<input type="radio"/>			<input type="radio"/>
2	<input type="radio"/>	<input type="radio"/>	<input type="radio"/>	<input type="radio"/>		<input type="radio"/>		<input type="radio"/>	<input type="radio"/>	<input type="radio"/>		
3	<input type="radio"/>	<input type="radio"/>	<input type="radio"/>	<input type="radio"/>	<input type="radio"/>	<input type="radio"/>	<input type="radio"/>	<input type="radio"/>				
4	<input type="radio"/>	<input type="radio"/>	<input type="radio"/>	<input type="radio"/>		<input type="radio"/>		<input type="radio"/>		<input type="radio"/>		<input type="radio"/>
5	<input type="radio"/>	<input type="radio"/>	<input type="radio"/>	<input type="radio"/>	<input type="radio"/>			<input type="radio"/>		<input type="radio"/>	<input type="radio"/>	

**Legend**

- : Setting
- Blank : No setting



Channel	Bit 2	Bit 1	Bit 0	Description	
	TPSC2	TPSC1	TPSC0		
0	0	0	0	Internal clock: counts on $\phi/1$ (Initial value)	
			1	Internal clock: counts on $\phi/4$	
			1	0	Internal clock: counts on $\phi/16$
			1	Internal clock: counts on $\phi/64$	
	1	0	0	External clock: counts on TCLKA pin input	
			1	External clock: counts on TCLKB pin input	
			1	0	External clock: counts on TCLKC pin input
			1	External clock: counts on TCLKD pin input	

Channel	Bit 2	Bit 1	Bit 0	Description	
	TPSC2	TPSC1	TPSC0		
1	0	0	0	Internal clock: counts on $\phi/1$ (Initial value)	
			1	Internal clock: counts on $\phi/4$	
			1	0	Internal clock: counts on $\phi/16$
			1	Internal clock: counts on $\phi/64$	
	1	0	0	External clock: counts on TCLKA pin input	
			1	External clock: counts on TCLKB pin input	
			1	0	Internal clock: counts on $\phi/256$
			1	Counts on TCNT2 overflow/underflow	

Note: This setting is ignored when channel 1 is in phase counting mode.

Channel	Bit 2	Bit 1	Bit 0	Description	
	TPSC2	TPSC1	TPSC0		
2	0	0	0	Internal clock: counts on $\phi/1$ (Initial value)	
			1	Internal clock: counts on $\phi/4$	
			1	0	Internal clock: counts on $\phi/16$
			1	Internal clock: counts on $\phi/64$	
	1	0	0	External clock: counts on TCLKA pin input	
			1	External clock: counts on TCLKB pin input	
			1	0	External clock: counts on TCLKC pin input
			1	Internal clock: counts on $\phi/1024$	

Note: This setting is ignored when channel 2 is in phase counting mode.

Channel	Bit 2	Bit 1	Bit 0	Description
	TPSC2	TPSC1	TPSC0	
3	0	0	0	Internal clock: counts on $\phi/1$ (Initial value)
			1	Internal clock: counts on $\phi/4$
		1	0	Internal clock: counts on $\phi/16$
			1	Internal clock: counts on $\phi/64$
	1	0	0	External clock: counts on TCLKA pin input
			1	Internal clock: counts on $\phi/1024$
		1	0	Internal clock: counts on $\phi/256$
			1	Internal clock: counts on $\phi/4096$

Channel	Bit 2	Bit 1	Bit 0	Description
	TPSC2	TPSC1	TPSC0	
4	0	0	0	Internal clock: counts on $\phi/1$ (Initial value)
			1	Internal clock: counts on $\phi/4$
		1	0	Internal clock: counts on $\phi/16$
			1	Internal clock: counts on $\phi/64$
	1	0	0	External clock: counts on TCLKA pin input
			1	External clock: counts on TCLKC pin input
		1	0	Internal clock: counts on $\phi/1024$
			1	Counts on TCNT5 overflow/underflow

Note: This setting is ignored when channel 4 is in phase counting mode.

Channel	Bit 2	Bit 1	Bit 0	Description
	TPSC2	TPSC1	TPSC0	
5	0	0	0	Internal clock: counts on $\phi/1$ (Initial value)
			1	Internal clock: counts on $\phi/4$
		1	0	Internal clock: counts on $\phi/16$
			1	Internal clock: counts on $\phi/64$
	1	0	0	External clock: counts on TCLKA pin input
			1	External clock: counts on TCLKC pin input
		1	0	Internal clock: counts on $\phi/256$
			1	External clock: counts on TCLKD pin input

Note: This setting is ignored when channel 5 is in phase counting mode.

## 11.2.2 Timer Mode Register (TMDR)

### Channel 0: TMDR0

### Channel 3: TMDR3

Bit	:	7	6	5	4	3	2	1	0
		—	—	BFB	BFA	MD3	MD2	MD1	MD0
Initial value :		1	1	0	0	0	0	0	0
R/W	:	—	—	R/W	R/W	R/W	R/W	R/W	R/W

### Channel 1: TMDR1

### Channel 2: TMDR2

### Channel 4: TMDR4

### Channel 5: TMDR5

Bit	:	7	6	5	4	3	2	1	0
		—	—	—	—	MD3	MD2	MD1	MD0
Initial value :		1	1	0	0	0	0	0	0
R/W	:	—	—	—	—	R/W	R/W	R/W	R/W

The TMDR registers are 8-bit readable/writable registers that are used to set the operating mode for each channel. The TPU has six TMDR registers, one for each channel. The TMDR registers are initialized to H'C0 by a reset, and in hardware standby mode.

TMDR register settings should be made only when TCNT operation is stopped.

**Bits 7 and 6—Reserved:** These bits are always read as 1 and cannot be modified.

**Bit 5—Buffer Operation B (BFB):** Specifies whether TGRB is to operate in the normal way, or TGRB and TGRD are to be used together for buffer operation. When TGRD is used as a buffer register, TGRD input capture/output compare is not generated.

In channels 1, 2, 4, and 5, which have no TGRD, bit 5 is reserved. It is always read as 0 and cannot be modified.

#### Bit 5

BFB	Description
0	TGRB operates normally (Initial value)
1	TGRB and TGRD used together for buffer operation

**Bit 4—Buffer Operation A (BFA):** Specifies whether TGRA is to operate in the normal way, or TGRA and TGRC are to be used together for buffer operation. When TGRC is used as a buffer register, TGRC input capture/output compare is not generated.

In channels 1, 2, 4, and 5, which have no TGRC, bit 4 is reserved. It is always read as 0 and cannot be modified.

**Bit 4**

BFA	Description
0	TGRA operates normally (Initial value)
1	TGRA and TGRC used together for buffer operation

**Bits 3 to 0—Modes 3 to 0 (MD3 to MD0):** These bits are used to set the timer operating mode.

Bit 3	Bit 2	Bit 1	Bit 0	Description
MD3* <sup>1</sup>	MD2* <sup>2</sup>	MD1	MD0	
0	0	0	0	Normal operation (Initial value)
			1	Reserved
		1	0	PWM mode 1
			1	PWM mode 2
	1	0	0	Phase counting mode 1
			1	Phase counting mode 2
		1	0	Phase counting mode 3
			1	Phase counting mode 4
1	*	*	*	—

\*: Don't care

Notes: \*1 MD3 is a reserved bit. In a write, it should always be written with 0.

\*2 Phase counting mode cannot be set for channels 0 and 3. In this case, 0 should always be written to MD2.

### 11.2.3 Timer I/O Control Register (TIOR)

**Channel 0: TIOR0H**

**Channel 1: TIOR1**

**Channel 2: TIOR2**

**Channel 3: TIOR3H**

**Channel 4: TIOR4**

**Channel 5: TIOR5**

Bit	:	7	6	5	4	3	2	1	0
		IOB3	IOB2	IOB1	IOB0	IOA3	IOA2	IOA1	IOA0
Initial value :		0	0	0	0	0	0	0	0
R/W	:	R/W	R/W	R/W	R/W	R/W	R/W	R/W	R/W

**Channel 0: TIOR0L**

**Channel 3: TIOR3L**

Bit	:	7	6	5	4	3	2	1	0
		IOD3	IOD2	IOD1	IOD0	IOC3	IOC2	IOC1	IOC0
Initial value :		0	0	0	0	0	0	0	0
R/W	:	R/W	R/W	R/W	R/W	R/W	R/W	R/W	R/W

Note: When TGRC or TGRD is designated for buffer operation, this setting is invalid and the register operates as a buffer register.

The TIOR registers are 8-bit registers that control the TGR registers. The TPU has eight TIOR registers, two each for channels 0 and 3, and one each for channels 1, 2, 4, and 5. The TIOR registers are initialized to H'00 by a reset, and in hardware standby mode.

Care is required since TIOR is affected by the TMDR setting. The initial output specified by TIOR is valid when the counter is stopped (the CST bit in TSTR is cleared to 0). Note also that, in PWM mode 2, the output at the point at which the counter is cleared to 0 is specified.

**Bits 7 to 4— I/O Control B3 to B0 (IOB3 to IOB0)**

**I/O Control D3 to D0 (IOD3 to IOD0):**

Bits IOB3 to IOB0 specify the function of TGRB.

Bits IOD3 to IOD0 specify the function of TGRD.

Channel	Bit 7	Bit 6	Bit 5	Bit 4	Description
	IOB3	IOB2	IOB1	IOB0	
0	0	0	0	0	TGR0B is Output disabled (Initial value)
				1	output
				0	Initial output is 0
				1	0 output at compare match
	1	0	0	0	compare register
				1	1 output at compare match
				0	Toggle output at compare match
				1	Output disabled
1	0	0	0	Initial output is 1	
			1	0 output at compare match	
			0	1 output at compare match	
			1	Toggle output at compare match	
1	0	0	0	TGR0B is Capture input	
			1	input source is	
			0	TIOCB0 pin	
			1	Input capture at rising edge	
1	0	0	1	capture register	
			0	Input capture at falling edge	
			1	Input capture at both edges	
			*	Input capture at TCNT1	
1	0	0	*	capture input	
			*	source is channel	
1	0	0	*	1/count clock	
			*	count- up/count-down* <sup>1</sup>	

\*: Don't care

Note: \*1 When bits TPSC2 to TPSC0 in TCR1 are set to B'000 and  $\emptyset/1$  is used as the TCNT1 count clock, this setting is invalid and input capture is not generated.

Channel	Bit 7	Bit 6	Bit 5	Bit 4	Description
	IOD3	IOD2	IOD1	IOD0	
0	0	0	0	0	TGR0D is Output disabled (Initial value)
				1	output
				0	Initial output is 0
				1	0 output at compare match
	0	0	1	0	output
				1	1 output at compare match
				0	Toggle output at compare match
				1	Toggle output at compare match
	1	0	0	0	Output disabled
				1	Initial output is 1
				0	0 output at compare match
				1	1 output at compare match
1	0	1	0	output	
			1	1 output at compare match	
			0	Toggle output at compare match	
			1	Toggle output at compare match	
1	0	0	0	TGR0D is Capture input	
			1	input	
			*	source is	
			*	TIOCD0 pin	
1	0	1	*	capture	
			*	register* <sup>2</sup>	
			*	Input capture at rising edge	
			*	Input capture at falling edge	
1	1	*	*	capture	
			*	register* <sup>2</sup>	
			*	Input capture at both edges	
			*	Input capture at TCNT1	
1	1	*	*	Capture input	
			*	source is channel	
			*	count-up/count-down* <sup>1</sup>	
			*	1/count clock	

\*: Don't care

Notes: \*1 When bits TPSC2 to TPSC0 in TCR1 are set to B'000 and  $\emptyset/1$  is used as the TCNT1 count clock, this setting is invalid and input capture is not generated.

\*2 When the BFB bit in TMDR0 is set to 1 and TGR0D is used as a buffer register, this setting is invalid and input capture/output compare is not generated.

Channel	Bit 7	Bit 6	Bit 5	Bit 4	Description
	IOB3	IOB2	IOB1	IOB0	
1	0	0	0	0	TGR1B is Output disabled (Initial value)
				1	output compare register
				0	Initial output is 0 output
				1	0 output at compare match
				0	1 output at compare match
				1	Toggle output at compare match
	1	0	0	0	Output disabled
				1	Initial output is 1 output
				0	0 output at compare match
				1	1 output at compare match
				0	Toggle output at compare match
				1	Toggle output at compare match
1	0	0	0	TGR1B is Capture input source is TIOCB1 pin	
			1	capture register	
			0	Input capture at rising edge	
			1	Input capture at falling edge	
			*	Input capture at both edges	
			*	Capture input source is TGR0C compare match/ input capture	
1	TGR0C compare match/ capture				

\*: Don't care

Channel	Bit 7	Bit 6	Bit 5	Bit 4	Description
	IOB3	IOB2	IOB1	IOB0	
2	0	0	0	0	TGR2B is Output disabled (Initial value)
				1	output compare register
				0	Initial output is 0 output
				1	0 output at compare match
				0	1 output at compare match
				1	Toggle output at compare match
	1	0	0	0	Output disabled
				1	Initial output is 1 output
				0	0 output at compare match
				1	1 output at compare match
				0	Toggle output at compare match
				1	Toggle output at compare match
1	*	0	0	TGR2B is Capture input source is TIOCB2 pin	
			1	capture register	
			0	Input capture at rising edge	
			1	Input capture at falling edge	
			*	Input capture at both edges	
			*	Input capture at both edges	

\*: Don't care



Channel	Bit 7	Bit 6	Bit 5	Bit 4	Description
	IOB3	IOB2	IOB1	IOB0	
3	0	0	0	0	TGR3B is Output disabled (Initial value)
				1	output compare register
				0	Initial output is 0 output
				1	0 output at compare match 1 output at compare match Toggle output at compare match
	1	0	0	0	Output disabled
				1	Initial output is 1 output
				0	0 output at compare match 1 output at compare match
				1	Toggle output at compare match
	1	0	0	0	TGR3B is Capture input source is TIOCB3 pin
				1	input capture register
				*	Input capture at rising edge Input capture at falling edge Input capture at both edges
				*	Input capture at TCNT4 count-up/count-down* <sup>1</sup> 4/count clock

\*: Don't care

Note: \*1 When bits TPSC2 to TPSC0 in TCR4 are set to B'000 and ø/1 is used as the TCNT4 count clock, this setting is invalid and input capture is not generated.

Channel	Bit 7 Bit 6 Bit 5 Bit 4				Description		
	IOD3	IOD2	IOD1	IOD0			
3	0	0	0	0	TGR3D is Output disabled (Initial value)		
				1	output compare register* <sup>2</sup>	Initial output is 0 output	0 output at compare match
				0		1 output at compare match	1 output at compare match
				1		Toggle output at compare match	Toggle output at compare match
	1	0	0	0		Output disabled	
				1		Initial output is 1 output	0 output at compare match
				0		1 output at compare match	1 output at compare match
				1		Toggle output at compare match	Toggle output at compare match
	1	0	0	0	TGR3D is Capture input source is TIOCD3 pin	Input capture at rising edge	
				1	capture register* <sup>2</sup>	Input capture at falling edge	Input capture at falling edge
				1	*	Input capture at both edges	Input capture at both edges
				1	*	*	Capture input source is channel 4/count clock

\*: Don't care

Notes: \*1 When bits TPSC2 to TPSC0 in TCR4 are set to B'000 and  $\emptyset$ /1 is used as the TCNT4 count clock, this setting is invalid and input capture is not generated.

\*2 When the BFB bit in TMDR3 is set to 1 and TGR3D is used as a buffer register, this setting is invalid and input capture/output compare is not generated.

Channel	Bit 7	Bit 6	Bit 5	Bit 4	Description
	IOB3	IOB2	IOB1	IOB0	
4	0	0	0	0	TGR4B is Output disabled (Initial value)
				1	output compare register
				0	Initial output is 0 output
				1	0 output at compare match 1 output at compare match Toggle output at compare match
	1	0	0	0	Output disabled
				1	Initial output is 1 output
				0	0 output at compare match 1 output at compare match Toggle output at compare match
				1	
	1	0	0	0	TGR4B is Capture input source is TIOCB4 pin
				1	input capture register
				*	Input capture at rising edge Input capture at falling edge Input capture at both edges
				*	Capture input source is TGR3C compare match/ input capture

\*: Don't care

Channel	Bit 7	Bit 6	Bit 5	Bit 4	Description
	IOB3	IOB2	IOB1	IOB0	
5	0	0	0	0	TGR5B is Output disabled (Initial value)
				1	output compare register
				0	Initial output is 0 output
				1	0 output at compare match 1 output at compare match Toggle output at compare match
	1	0	0	0	Output disabled
				1	Initial output is 1 output
				0	0 output at compare match 1 output at compare match Toggle output at compare match
				1	
	1	*	0	0	TGR5B is Capture input source is TIOCB5 pin
				1	input capture register
				*	Input capture at rising edge Input capture at falling edge Input capture at both edges
				*	

\*: Don't care

**Bits 3 to 0— I/O Control A3 to A0 (IOA3 to IOA0)  
I/O Control C3 to C0 (IOC3 to IOC0):**

IOA3 to IOA0 specify the function of TGRA.

IOC3 to IOC0 specify the function of TGRC.

Channel	Bit 3	Bit 2	Bit 1	Bit 0	Description
	IOA3	IOA2	IOA1	IOA0	
0	0	0	0	0	TGR0A is Output disabled (Initial value)
				1	output
				0	Initial output is 0
				1	0 output at compare match
	1	0	0	0	compare register
				1	1 output at compare match
				0	Toggle output at compare match
				1	Output disabled
1	0	0	0	Output disabled	
			1	Initial output is 1	
			0	0 output at compare match	
			1	1 output at compare match	
1	0	0	0	TGR0A is Capture input	
			1	input source is	
			*	TIOCA0 pin	
			*	Input capture at rising edge	
1	0	0	0	capture register	
			1	Input capture at falling edge	
			*	Input capture at both edges	
			*	Input capture at TCNT1	
1	0	0	0	Capture input	
			1	source is channel	
			*	count-up/count-down	
			*	1/ count clock	

\*: Don't care

Channel	Bit 3	Bit 2	Bit 1	Bit 0	Description
	IOC3	IOC2	IOC1	IOC0	
0	0	0	0	0	TGR0C is Output disabled (Initial value)
				1	output compare register*1
				0	Initial output is 0 output
				1	0 output at compare match 1 output at compare match Toggle output at compare match
	1	0	0	0	Output disabled
				1	Initial output is 1 output
				0	0 output at compare match 1 output at compare match
				1	Toggle output at compare match
	1	0	0	0	TGR0C is Capture input source is TIOCC0 pin
				1	input capture register*1
				*	Input capture at rising edge Input capture at falling edge Input capture at both edges
				*	Input capture at TCNT1 count-up/count-down 1/count clock

\*: Don't care

Note: \*1 When the BFA bit in TMDR0 is set to 1 and TGR0C is used as a buffer register, this setting is invalid and input capture/output compare is not generated.

Channel	Bit 3	Bit 2	Bit 1	Bit 0	Description		
	IOA3	IOA2	IOA1	IOA0			
1	0	0	0	0	TGR1A is Output disabled (Initial value)		
				1	output compare register	Initial output is 0 output	0 output at compare match
				0		1 output at compare match	
				1		Toggle output at compare match	
	1	0	0	0	Output disabled		
				1	output compare register	Initial output is 1 output	0 output at compare match
				0		1 output at compare match	
				1		Toggle output at compare match	
	1	0	0	0	TGR1A is Capture input source is TIOCA1 pin		
				1	input capture register	Input capture at rising edge	Input capture at falling edge
				*		Input capture at both edges	
				*		Input capture at generation of channel 0/TGR0A compare match/input capture	

\*: Don't care

Channel	Bit 3	Bit 2	Bit 1	Bit 0	Description		
	IOA3	IOA2	IOA1	IOA0			
2	0	0	0	0	TGR2A is Output disabled (Initial value)		
				1	output compare register	Initial output is 0 output	0 output at compare match
				0		1 output at compare match	
				1		Toggle output at compare match	
	1	0	0	0	Output disabled		
				1	output compare register	Initial output is 1 output	0 output at compare match
				0		1 output at compare match	
				1		Toggle output at compare match	
	1	*	0	0	TGR2A is Capture input source is TIOCA2 pin		
				1	input capture register	Input capture at rising edge	Input capture at falling edge
				*		Input capture at both edges	
				*		Input capture at generation of channel 0/TGR0A compare match/input capture	

\*: Don't care

Channel	Bit 3	Bit 2	Bit 1	Bit 0	Description
	IOA3	IOA2	IOA1	IOA0	
3	0	0	0	0	TGR3A is Output disabled (Initial value)
				1	output compare register
				0	Initial output is 0 output
				1	0 output at compare match 1 output at compare match Toggle output at compare match
	1	0	0	0	Output disabled
				1	Initial output is 1 output
				0	0 output at compare match 1 output at compare match
				1	Toggle output at compare match
1	0	0	0	TGR3A is Capture input source is TIOCA3 pin	
			1	input capture register	
			*	Input capture at rising edge Input capture at falling edge Input capture at both edges	
			*	Input capture at TCNT4 count-up/count-down 4/count clock	

\*: Don't care

Channel	Bit 3	Bit 2	Bit 1	Bit 0	Description
	IOC3	IOC2	IOC1	IOC0	
3	0	0	0	0	TGR3C is Output disabled (Initial value)
				1	output Initial output is 0
				0	compare 0 output at compare match
				1	register* <sup>1</sup> 1 output at compare match
	1	0	0	0	Output disabled
				1	Initial output is 1
				0	0 output at compare match
				1	1 output at compare match
1	0	0	0	TGR3C is Capture input	
			1	input source is	
			*	TIOCC3 pin	
			*	Input capture at both edges	
1	1	*	*	Capture input	
			*	source is channel count-up/count-down 4/count clock	

\*: Don't care

Note: \*1 When the BFA bit in TMDR3 is set to 1 and TGR3C is used as a buffer register, this setting is invalid and input capture/output compare is not generated.



Channel	Bit 3	Bit 2	Bit 1	Bit 0	Description
	IOA3	IOA2	IOA1	IOA0	
4	0	0	0	0	TGR4A is Output disabled (Initial value)
				1	output compare register
				0	Initial output is 0 output
				1	0 output at compare match 1 output at compare match Toggle output at compare match
	1	0	0	0	Output disabled
				1	Initial output is 1 output
				0	0 output at compare match 1 output at compare match Toggle output at compare match
				1	0 output at compare match 1 output at compare match Toggle output at compare match
	1	0	0	0	TGR4A is Capture input source is TIOCA4 pin
				1	input capture register
				*	Input capture at rising edge Input capture at falling edge Input capture at both edges
				*	Input capture at generation of TGR3A compare match/input capture

\*: Don't care

Channel	Bit 3	Bit 2	Bit 1	Bit 0	Description
	IOA3	IOA2	IOA1	IOA0	
5	0	0	0	0	TGR5A is Output disabled (Initial value)
				1	output compare register
				0	Initial output is 0 output
				1	0 output at compare match 1 output at compare match Toggle output at compare match
	1	0	0	0	Output disabled
				1	Initial output is 1 output
				0	0 output at compare match 1 output at compare match Toggle output at compare match
				1	0 output at compare match 1 output at compare match Toggle output at compare match
	1	*	0	0	TGR5A is Capture input source is TIOCA5 pin
				1	input capture register
				*	Input capture at rising edge Input capture at falling edge Input capture at both edges
				*	Input capture at generation of TGR3A compare match/input capture

\*: Don't care

### 11.2.4 Timer Interrupt Enable Register (TIER)

#### Channel 0: TIER0

#### Channel 3: TIER3

Bit	:	7	6	5	4	3	2	1	0
		TTGE	—	—	TCIEV	TGIED	TGIEC	TGIEB	TGIEA
Initial value :		0	1	0	0	0	0	0	0
R/W	:	R/W	—	—	R/W	R/W	R/W	R/W	R/W

#### Channel 1: TIER1

#### Channel 2: TIER2

#### Channel 4: TIER4

#### Channel 5: TIER5

Bit	:	7	6	5	4	3	2	1	0
		TTGE	—	TCIEU	TCIEV	—	—	TGIEB	TGIEA
Initial value :		0	1	0	0	0	0	0	0
R/W	:	R/W	—	R/W	R/W	—	—	R/W	R/W

The TIER registers are 8-bit registers that control enabling or disabling of interrupt requests for each channel. The TPU has six TIER registers, one for each channel. The TIER registers are initialized to H'40 by a reset, and in hardware standby mode.

**Bit 7—A/D Conversion Start Request Enable (TTGE):** Enables or disables generation of A/D conversion start requests by TGRA input capture/compare match.

**Bit 7**

TTGE	Description
0	A/D conversion start request generation disabled (Initial value)
1	A/D conversion start request generation enabled

**Bit 6—Reserved:** This bit is always read as 1 and cannot be modified.

**Bit 5—Underflow Interrupt Enable (TCIEU):** Enables or disables interrupt requests (TCIU) by the TCFU flag when the TCFU flag in TSR is set to 1 in channels 1, 2, 4, and 5.

In channels 0 and 3, bit 5 is reserved. It is always read as 0 and cannot be modified.

**Bit 5**

TCIEU	Description
0	Interrupt requests (TCIU) by TCFU disabled (Initial value)
1	Interrupt requests (TCIU) by TCFU enabled

**Bit 4—Overflow Interrupt Enable (TCIEV):** Enables or disables interrupt requests (TCIV) by the TCFV flag when the TCFV flag in TSR is set to 1.

**Bit 4**

TCIEV	Description
0	Interrupt requests (TCIV) by TCFV disabled (Initial value)
1	Interrupt requests (TCIV) by TCFV enabled

**Bit 3—TGR Interrupt Enable D (TGIED):** Enables or disables interrupt requests (TGID) by the TGFD bit when the TGFD bit in TSR is set to 1 in channels 0 and 3.

In channels 1, 2, 4, and 5, bit 3 is reserved. It is always read as 0 and cannot be modified.

**Bit 3**

TGIED	Description
0	Interrupt requests (TGID) by TGFD bit disabled (Initial value)
1	Interrupt requests (TGID) by TGFD bit enabled

**Bit 2—TGR Interrupt Enable C (TGIEC):** Enables or disables interrupt requests (TGIC) by the TGFC bit when the TGFC bit in TSR is set to 1 in channels 0 and 3.

In channels 1, 2, 4, and 5, bit 2 is reserved. It is always read as 0 and cannot be modified.

**Bit 2**

TGIEC	Description
0	Interrupt requests (TGIC) by TGFC bit disabled (Initial value)
1	Interrupt requests (TGIC) by TGFC bit enabled

**Bit 1—TGR Interrupt Enable B (TGIEB):** Enables or disables interrupt requests (TGIB) by the TGFB bit when the TGFB bit in TSR is set to 1.

**Bit 1**

TGIEB	Description
0	Interrupt requests (TGIB) by TGFB bit disabled (Initial value)
1	Interrupt requests (TGIB) by TGFB bit enabled

**Bit 0—TGR Interrupt Enable A (TGIEA):** Enables or disables interrupt requests (TGIA) by the TGFA bit when the TGFA bit in TSR is set to 1.

**Bit 0**

TGIEA	Description
0	Interrupt requests (TGIA) by TGFA bit disabled (Initial value)
1	Interrupt requests (TGIA) by TGFA bit enabled

## 11.2.5 Timer Status Register (TSR)

### Channel 0: TSR0

### Channel 3: TSR3

Bit	:	7	6	5	4	3	2	1	0
		—	—	—	TCFV	TGFD	TGFC	TGFB	TGFA
Initial value :		1	1	0	0	0	0	0	0
R/W	:	—	—	—	R/(W)*	R/(W)*	R/(W)*	R/(W)*	R/(W)*

Note: \* Only 0 can be written, for flag clearing.

### Channel 1: TSR1

### Channel 2: TSR2

### Channel 4: TSR4

### Channel 5: TSR5

Bit	:	7	6	5	4	3	2	1	0
		TCFD	—	TCFU	TCFV	—	—	TGFB	TGFA
Initial value :		1	1	0	0	0	0	0	0
R/W	:	R	—	R/(W)*	R/(W)*	—	—	R/(W)*	R/(W)*

Note: \* Only 0 can be written, for flag clearing.

The TSR registers are 8-bit registers that indicate the status of each channel. The TPU has six TSR registers, one for each channel. The TSR registers are initialized to H'00 by a reset, and in hardware standby mode.

**Bit 7—Count Direction Flag (TCFD):** Status flag that shows the direction in which TCNT counts in channels 1, 2, 4, and 5.

In channels 0 and 3, bit 7 is reserved. It is always read as 1 and cannot be modified.

**Bit 7**

TCFD	Description
0	TCNT counts down
1	TCNT counts up (Initial value)

**Bit 6—Reserved:** This bit is always read as 1 and cannot be modified.

**Bit 5—Underflow Flag (TCFU):** Status flag that indicates that TCNT underflow has occurred when channels 1, 2, 4, and 5 are set to phase counting mode.

In channels 0 and 3, bit 5 is reserved. It is always read as 0 and cannot be modified.

**Bit 5**

TCFU	Description
0	[Clearing condition] (Initial value) When 0 is written to TCFU after reading TCFU = 1
1	[Setting condition] When the TCNT value underflows (changes from H'0000 to H'FFFF)

**Bit 4—Overflow Flag (TCFV):** Status flag that indicates that TCNT overflow has occurred.

**Bit 4**

TCFV	Description
0	[Clearing condition] (Initial value) When 0 is written to TCFV after reading TCFV = 1
1	[Setting condition] When the TCNT value overflows (changes from H'FFFF to H'0000 )

**Bit 3—Input Capture/Output Compare Flag D (TGFD):** Status flag that indicates the occurrence of TGRD input capture or compare match in channels 0 and 3.

In channels 1, 2, 4, and 5, bit 3 is reserved. It is always read as 0 and cannot be modified.

**Bit 3**

TGFD	Description
0	[Clearing conditions] (Initial value) <ul style="list-style-type: none"> <li>When DTC* is activated by TGID interrupt while DISEL bit of MRB in DTC* is 0</li> <li>When 0 is written to TGFD after reading TGFD = 1</li> </ul>
1	[Setting conditions] <ul style="list-style-type: none"> <li>When TCNT = TGRD while TGRD is functioning as output compare register</li> <li>When TCNT value is transferred to TGRD by input capture signal while TGRD is functioning as input capture register</li> </ul>

Note: \* This function is not available in the H8S/2695.

**Bit 2—Input Capture/Output Compare Flag C (TGFC):** Status flag that indicates the occurrence of TGRC input capture or compare match in channels 0 and 3.

In channels 1, 2, 4, and 5, bit 2 is reserved. It is always read as 0 and cannot be modified.

**Bit 2**

TGFC	Description
0	[Clearing conditions] (Initial value) <ul style="list-style-type: none"> <li>When DTC* is activated by TGIC interrupt while DISEL bit of MRB in DTC* is 0</li> <li>When 0 is written to TGFC after reading TGFC = 1</li> </ul>
1	[Setting conditions] <ul style="list-style-type: none"> <li>When TCNT = TGRC while TGRC is functioning as output compare register</li> <li>When TCNT value is transferred to TGRC by input capture signal while TGRC is functioning as input capture register</li> </ul>

Note: \* This function is not available in the H8S/2695.

**Bit 1—Input Capture/Output Compare Flag B (TGFB):** Status flag that indicates the occurrence of TGRB input capture or compare match.

**Bit 1**

TGFB	Description
0	[Clearing conditions] (Initial value) <ul style="list-style-type: none"> <li>• When DTC* is activated by TGIB interrupt while DISEL bit of MRB in DTC* is 0</li> <li>• When 0 is written to TGFB after reading TGFB = 1</li> </ul>
1	[Setting conditions] <ul style="list-style-type: none"> <li>• When TCNT = TGRB while TGRB is functioning as output compare register</li> <li>• When TCNT value is transferred to TGRB by input capture signal while TGRB is functioning as input capture register</li> </ul>

Note: \* This function is not available in the H8S/2695.

**Bit 0—Input Capture/Output Compare Flag A (TGFA):** Status flag that indicates the occurrence of TGRA input capture or compare match.

**Bit 0**

TGFA	Description
0	[Clearing conditions] (Initial value) <ul style="list-style-type: none"> <li>• When DTC* is activated by TGIA interrupt while DISEL bit of MRB in DTC* is 0</li> <li>• When DMAC* is activated by TGIA interrupt while DTA bit of DMABCR in DMAC* is 1</li> <li>• When 0 is written to TGFA after reading TGFA = 1</li> </ul>
1	[Setting conditions] <ul style="list-style-type: none"> <li>• When TCNT = TGRA while TGRA is functioning as output compare register</li> <li>• When TCNT value is transferred to TGRA by input capture signal while TGRA is functioning as input capture register</li> </ul>

Note: \* This function is not available in the H8S/2695.



## 11.2.6 Timer Counter (TCNT)

**Channel 0: TCNT0 (up-counter)**

**Channel 1: TCNT1 (up/down-counter\*)**

**Channel 2: TCNT2 (up/down-counter\*)**

**Channel 3: TCNT3 (up-counter)**

**Channel 4: TCNT4 (up/down-counter\*)**

**Channel 5: TCNT5 (up/down-counter\*)**

Bit	:	15	14	13	12	11	10	9	8	7	6	5	4	3	2	1	0
Initial value :		0	0	0	0	0	0	0	0	0	0	0	0	0	0	0	0
R/W	:	R/W	R/W	R/W	R/W	R/W	R/W	R/W	R/W	R/W	R/W	R/W	R/W	R/W	R/W	R/W	R/W

Note: \* These counters can be used as up/down-counters only in phase counting mode or when counting overflow/underflow on another channel. In other cases they function as up-counters.

The TCNT registers are 16-bit counters. The TPU has six TCNT counters, one for each channel.

The TCNT counters are initialized to H'0000 by a reset, and in hardware standby mode.

The TCNT counters cannot be accessed in 8-bit units; they must always be accessed as a 16-bit unit.

### 11.2.7 Timer General Register (TGR)

Bit	:	15	14	13	12	11	10	9	8	7	6	5	4	3	2	1	0
Initial value	:	1	1	1	1	1	1	1	1	1	1	1	1	1	1	1	1
R/W	:	R/W	R/W	R/W	R/W	R/W	R/W	R/W	R/W	R/W	R/W	R/W	R/W	R/W	R/W	R/W	R/W

The TGR registers are 16-bit registers with a dual function as output compare and input capture registers. The TPU has 16 TGR registers, four each for channels 0 and 3 and two each for channels 1, 2, 4, and 5. TGRC and TGRD for channels 0 and 3 can also be designated for operation as buffer registers\*. The TGR registers are initialized to H'FFFF by a reset, and in hardware standby mode.

The TGR registers cannot be accessed in 8-bit units; they must always be accessed as a 16-bit unit.

Note: \* TGR buffer register combinations are TGRA—TGRC and TGRB—TGRD.

### 11.2.8 Timer Start Register (TSTR)

Bit	:	7	6	5	4	3	2	1	0
		—	—	CST5	CST4	CST3	CST2	CST1	CST0
Initial value :		0	0	0	0	0	0	0	0
R/W	:	—	—	R/W	R/W	R/W	R/W	R/W	R/W

TSTR is an 8-bit readable/writable register that selects operation/stoppage for channels 0 to 5. TSTR is initialized to H'00 by a reset, and in hardware standby mode. When setting the operating mode in TMDR or setting the count clock in TCR, first stop the TCNT counter.

**Bits 7 and 6—Reserved:** Should always be written with 0.

**Bits 5 to 0—Counter Start 5 to 0 (CST5 to CST0):** These bits select operation or stoppage for TCNT.

**Bit n**

CSTn	Description
0	TCNTn count operation is stopped (Initial value)
1	TCNTn performs count operation

n = 5 to 0

Note: If 0 is written to the CST bit during operation with the TIOC pin designated for output, the counter stops but the TIOC pin output compare output level is retained. If TIOR is written to when the CST bit is cleared to 0, the pin output level will be changed to the set initial output value.

### 11.2.9 Timer Synchro Register (TSYR)

Bit	:	7	6	5	4	3	2	1	0
		—	—	SYNC5	SYNC4	SYNC3	SYNC2	SYNC1	SYNC0
Initial value :		0	0	0	0	0	0	0	0
R/W	:	—	—	R/W	R/W	R/W	R/W	R/W	R/W

TSYR is an 8-bit readable/writable register that selects independent operation or synchronous operation for the channels 0 to 5 TCNT counters. A channel performs synchronous operation when the corresponding bit in TSYR is set to 1.

TSYR is initialized to H'00 by a reset, and in hardware standby mode.

**Bits 7 and 6—Reserved:** Should always be written with 0.

**Bits 5 to 0—Timer Synchro 5 to 0 (SYNC5 to SYNC0):** These bits select whether operation is independent of or synchronized with other channels.

When synchronous operation is selected, synchronous presetting of multiple channels\*<sup>1</sup>, and synchronous clearing through counter clearing on another channel\*<sup>2</sup> are possible.

Bit n	SYNCn	Description
	0	TCNTn operates independently (TCNT presetting/clearing is unrelated to other channels) (Initial value)
	1	TCNTn performs synchronous operation TCNT synchronous presetting/synchronous clearing is possible

n = 5 to 0

Notes: \*1 To set synchronous operation, the SYNC bits for at least two channels must be set to 1.

\*2 To set synchronous clearing, in addition to the SYNC bit, the TCNT clearing source must also be set by means of bits CCLR2 to CCLR0 in TCR.

### 11.2.10 Module Stop Control Register A (MSTPCRA)

Bit	:	7	6	5	4	3	2	1	0
		MSTPA7	MSTPA6	MSTPA5	MSTPA4	MSTPA3	MSTPA2	MSTPA1	MSTPA0
Initial value :		0	0	1	1	1	1	1	1
R/W	:	R/W	R/W	R/W	R/W	R/W	R/W	R/W	R/W

MSTPCRA is an 8-bit readable/writable register that performs module stop mode control.

When the MSTPA5 bit in MSTPCRA is set to 1, TPU operation stops at the end of the bus cycle and a transition is made to module stop mode. Registers cannot be read or written to in module stop mode. For details, see section 24.5, Module Stop Mode.

MSTPCRA is initialized to H'3F by a power-on reset and in hardware standby mode. It is not initialized by a manual reset and in software standby mode.

**Bit 5—Module Stop (MSTPA5):** Specifies the TPU module stop mode.

#### Bit 5

MSTPA5	Description
0	TPU module stop mode cleared
1	TPU module stop mode set (Initial value)

## 11.3 Interface to Bus Master

### 11.3.1 16-Bit Registers

TCNT and TGR are 16-bit registers. As the data bus to the bus master is 16 bits wide, these registers can be read and written to in 16-bit units.

These registers cannot be read or written to in 8-bit units; 16-bit access must always be used.

An example of 16-bit register access operation is shown in figure 11-2.

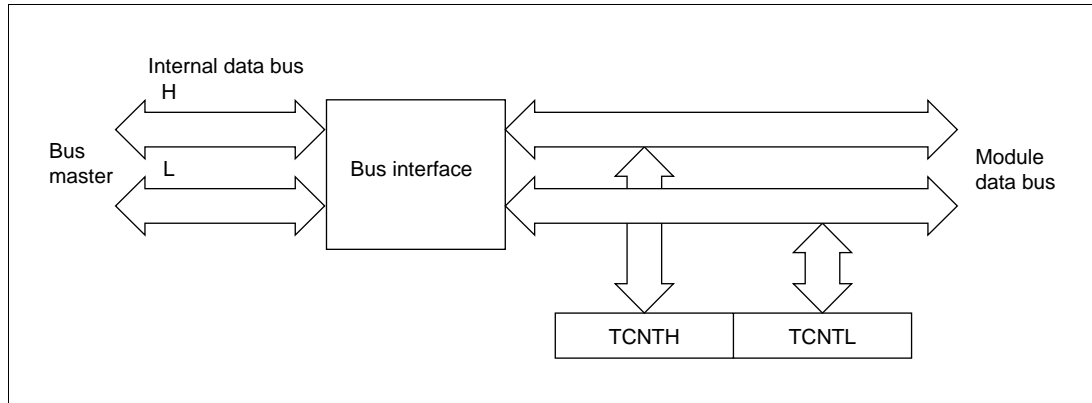
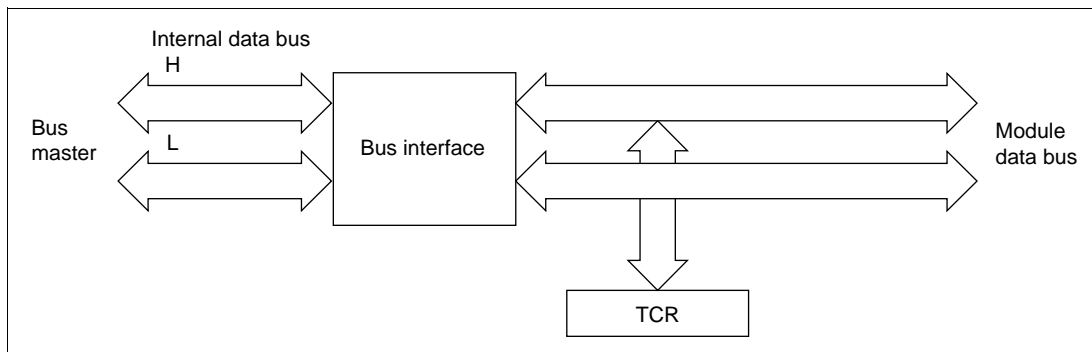


Figure 11-2 16-Bit Register Access Operation [Bus Master ↔ TCNT (16 Bits)]

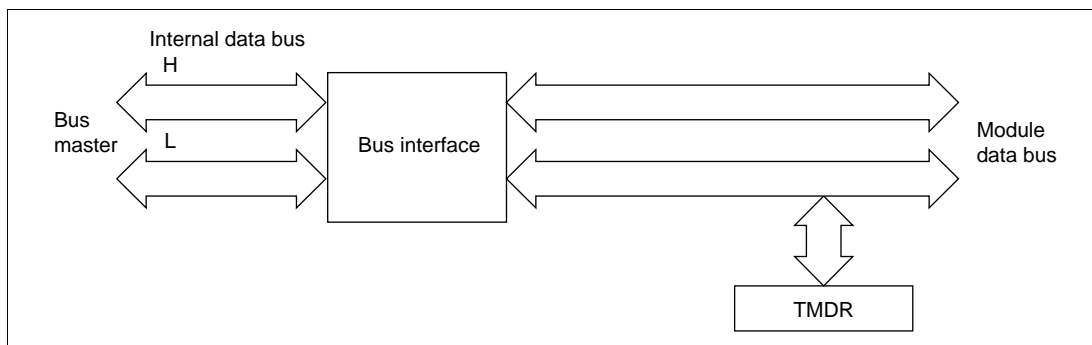
### 11.3.2 8-Bit Registers

Registers other than TCNT and TGR are 8-bit. As the data bus to the CPU is 16 bits wide, these registers can be read and written to in 16-bit units. They can also be read and written to in 8-bit units.

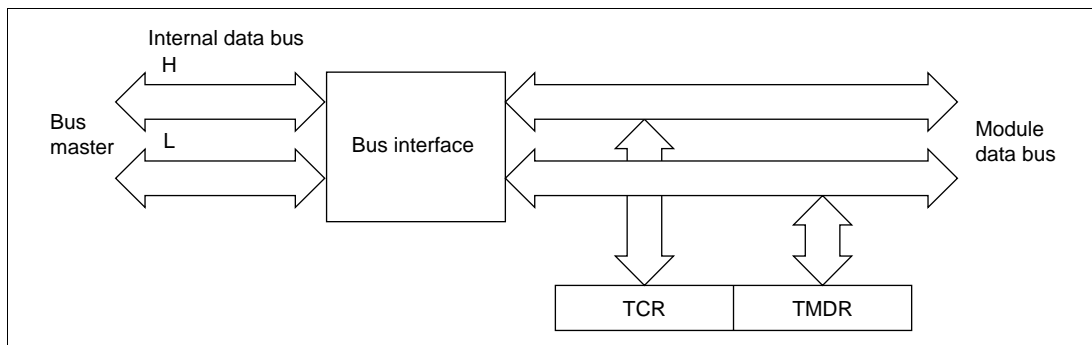
Examples of 8-bit register access operation are shown in figures 11-3, 11-4, and 11-5.



**Figure 11-3 8-Bit Register Access Operation [Bus Master ↔ TCR (Upper 8 Bits)]**



**Figure 11-4 8-Bit Register Access Operation [Bus Master ↔ TMDR (Lower 8 Bits)]**



**Figure 11-5 8-Bit Register Access Operation [Bus Master ↔ TCR and TMDR (16 Bits)]**

## 11.4 Operation

### 11.4.1 Overview

Operation in each mode is outlined below.

**Normal Operation:** Each channel has a TCNT and TGR register. TCNT performs up-counting, and is also capable of free-running operation, synchronous counting, and external event counting.

Each TGR can be used as an input capture register or output compare register.

**Synchronous Operation:** When synchronous operation is designated for a channel, TCNT for that channel performs synchronous presetting. That is, when TCNT for a channel designated for synchronous operation is rewritten, the TCNT counters for the other channels are also rewritten at the same time. Synchronous clearing of the TCNT counters is also possible by setting the timer synchronization bits in TSYR for channels designated for synchronous operation.

#### Buffer Operation

- When TGR is an output compare register  
When a compare match occurs, the value in the buffer register for the relevant channel is transferred to TGR.
- When TGR is an input capture register  
When input capture occurs, the value in TCNT is transfer to TGR and the value previously held in TGR is transferred to the buffer register.

**Cascaded Operation:** The channel 1 counter (TCNT1), channel 2 counter (TCNT2), channel 4 counter (TCNT4), and channel 5 counter (TCNT5) can be connected together to operate as a 32-bit counter.

**PWM Mode:** In this mode, a PWM waveform is output. The output level can be set by means of TIOR. A PWM waveform with a duty of between 0% and 100% can be output, according to the setting of each TGR register.

**Phase Counting Mode:** In this mode, TCNT is incremented or decremented by detecting the phases of two clocks input from the external clock input pins in channels 1, 2, 4, and 5. When phase counting mode is set, the corresponding TCLK pin functions as the clock pin, and TCNT performs up- or down-counting.

This can be used for two-phase encoder pulse input.

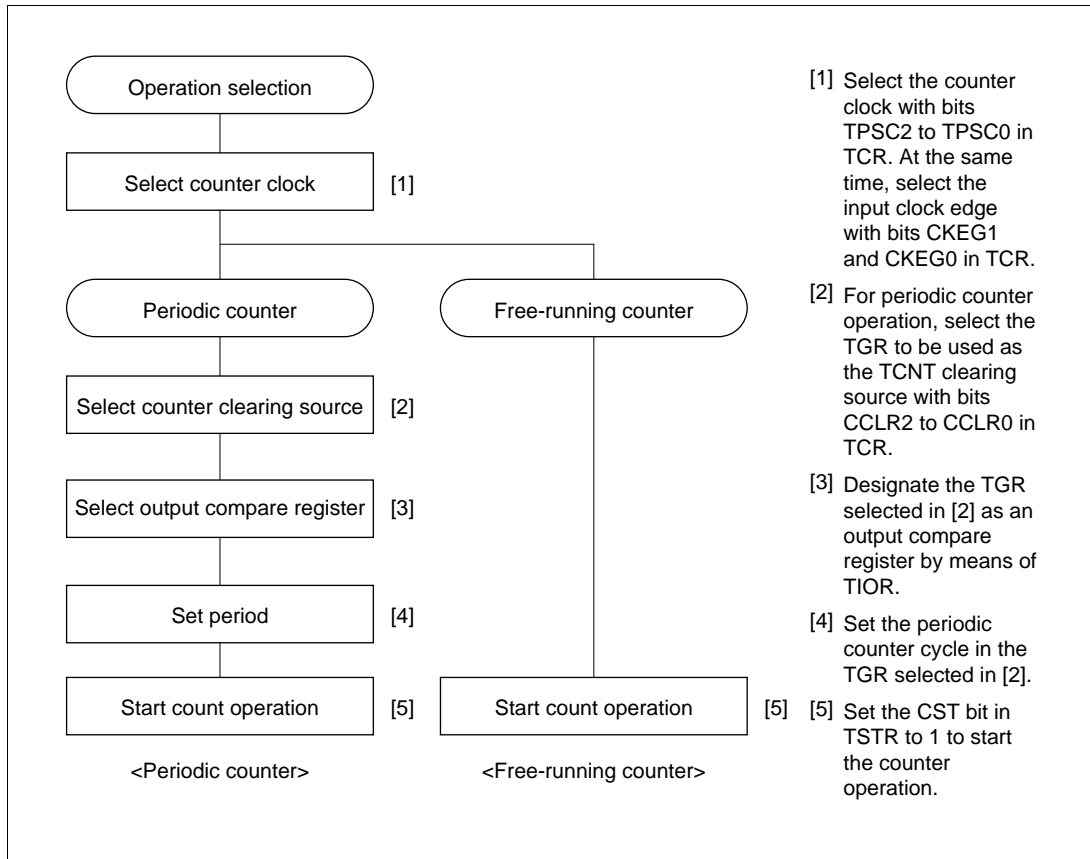


## 11.4.2 Basic Functions

**Counter Operation:** When one of bits CST0 to CST5 is set to 1 in TSTR, the TCNT counter for the corresponding channel starts counting. TCNT can operate as a free-running counter, periodic counter, and so on.

- Example of count operation setting procedure

Figure 11-6 shows an example of the count operation setting procedure.

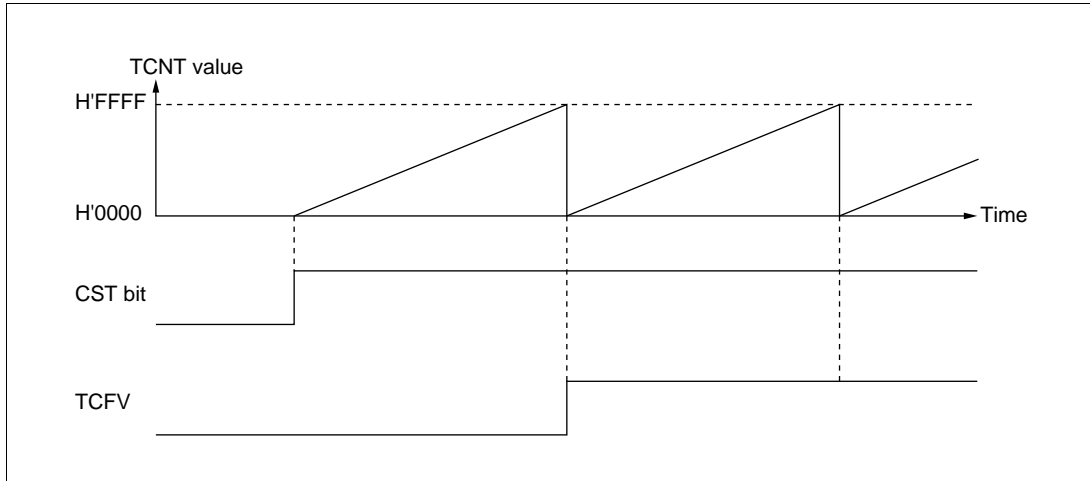


**Figure 11-6 Example of Counter Operation Setting Procedure**

- Free-running count operation and periodic count operation

Immediately after a reset, the TPU's TCNT counters are all designated as free-running counters. When the relevant bit in TSTR is set to 1 the corresponding TCNT counter starts up-count operation as a free-running counter. When TCNT overflows (from H'FFFF to H'0000), the TCFV bit in TSR is set to 1. If the value of the corresponding TCIEV bit in TIER is 1 at this point, the TPU requests an interrupt. After overflow, TCNT starts counting up again from H'0000.

Figure 11-7 illustrates free-running counter operation.

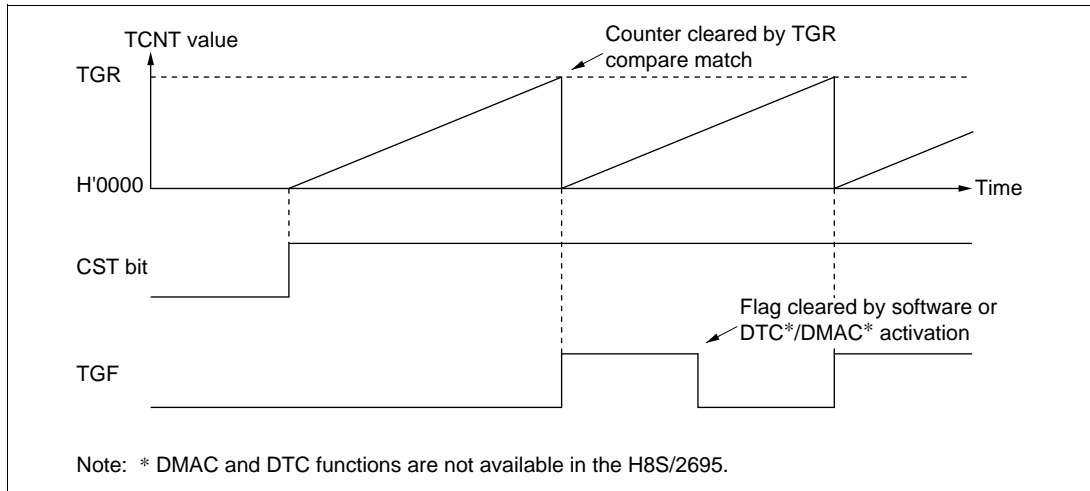


**Figure 11-7 Free-Running Counter Operation**

When compare match is selected as the TCNT clearing source, the TCNT counter for the relevant channel performs periodic count operation. The TGR register for setting the period is designated as an output compare register, and counter clearing by compare match is selected by means of bits CCLR2 to CCLR0 in TCR. After the settings have been made, TCNT starts up-count operation as periodic counter when the corresponding bit in TSTR is set to 1. When the count value matches the value in TGR, the TGF bit in TSR is set to 1 and TCNT is cleared to H'0000.

If the value of the corresponding TGIE bit in TIER is 1 at this point, the TPU requests an interrupt. After a compare match, TCNT starts counting up again from H'0000.

Figure 11-8 illustrates periodic counter operation.

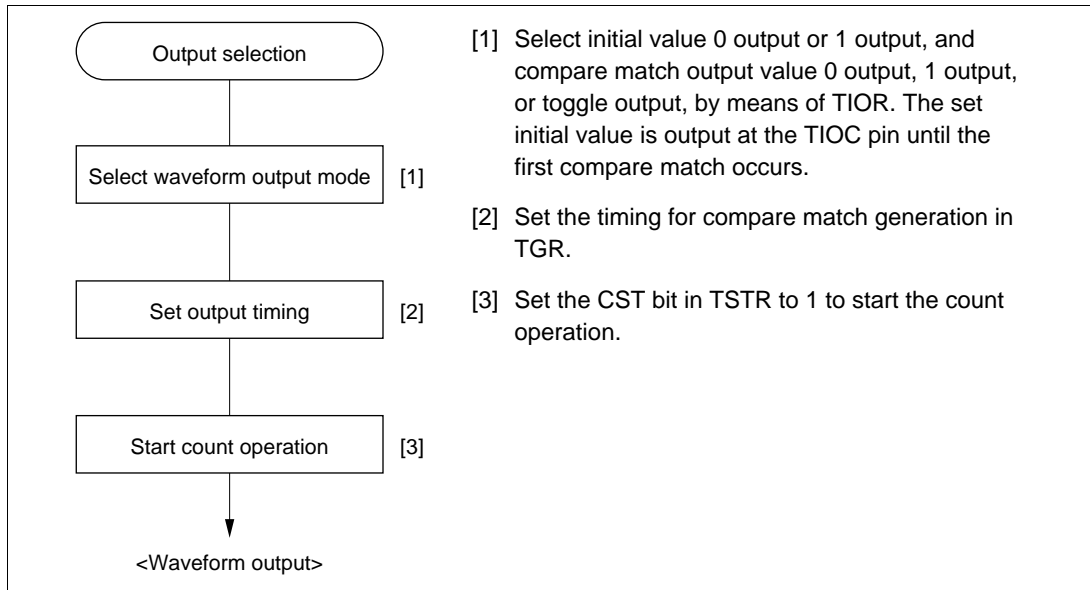


**Figure 11-8 Periodic Counter Operation**

**Waveform Output by Compare Match:** The TPU can perform 0, 1, or toggle output from the corresponding output pin using compare match.

- Example of setting procedure for waveform output by compare match

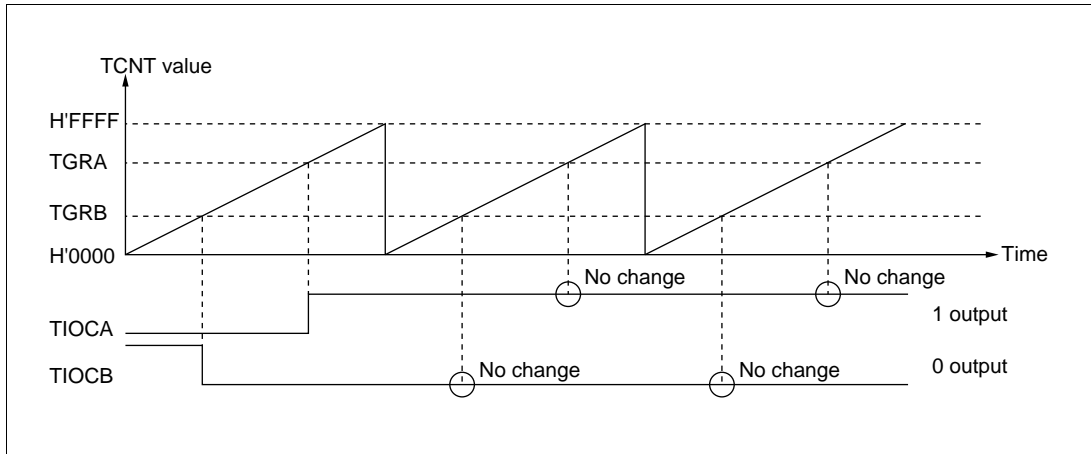
Figure 11-9 shows an example of the setting procedure for waveform output by compare match



**Figure 11-9 Example of Setting Procedure for Waveform Output by Compare Match**

- Examples of waveform output operation  
Figure 11-10 shows an example of 0 output/1 output.

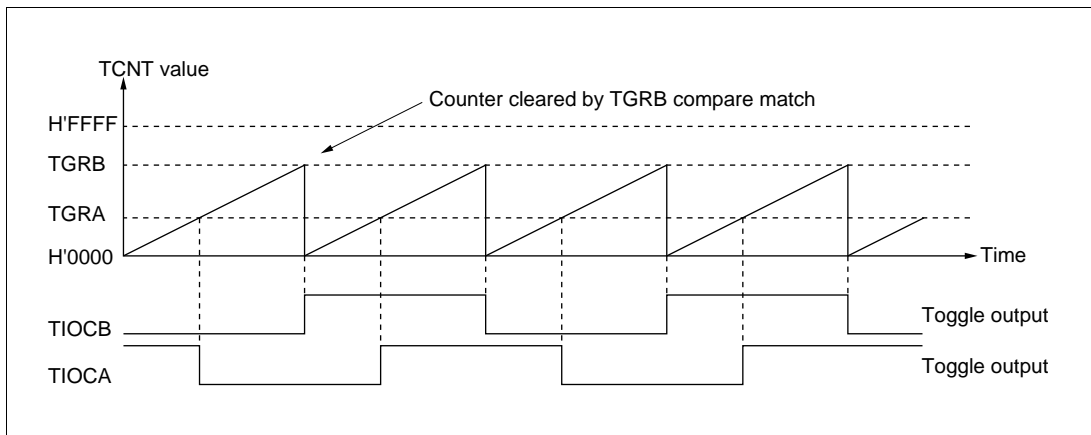
In this example TCNT has been designated as a free-running counter, and settings have been made so that 1 is output by compare match A, and 0 is output by compare match B. When the set level and the pin level coincide, the pin level does not change.



**Figure 11-10 Example of 0 Output/1 Output Operation**

Figure 11-11 shows an example of toggle output.

In this example TCNT has been designated as a periodic counter (with counter clearing performed by compare match B), and settings have been made so that output is toggled by both compare match A and compare match B.



**Figure 11-11 Example of Toggle Output Operation**

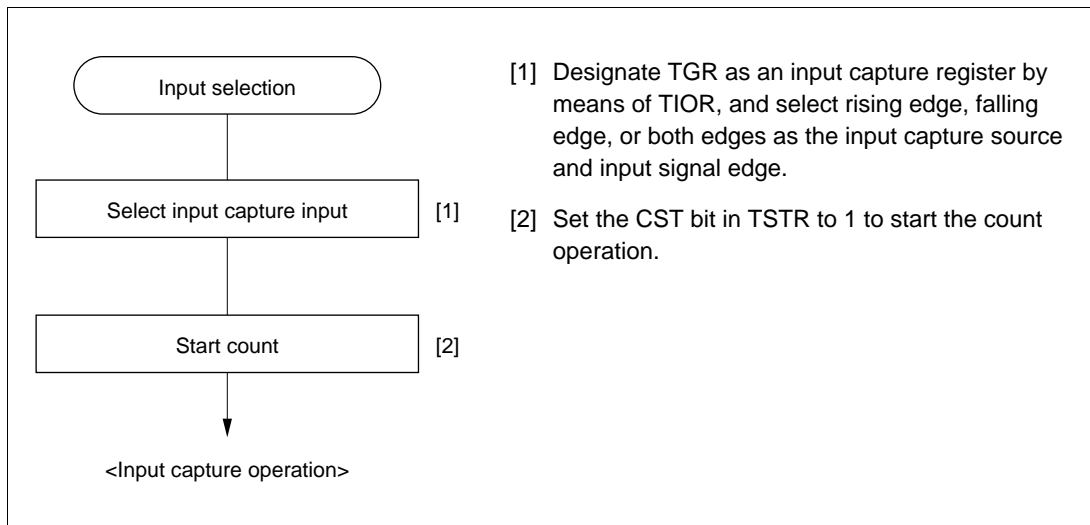
**Input Capture Function:** The TCNT value can be transferred to TGR on detection of the TIOC pin input edge.

Rising edge, falling edge, or both edges can be selected as the detected edge. For channels 0, 1, 3, and 4, it is also possible to specify another channel's counter input clock or compare match signal as the input capture source.

Note: When another channel's counter input clock is used as the input capture input for channels 0 and 3,  $\phi/1$  should not be selected as the counter input clock used for input capture input. Input capture will not be generated if  $\phi/1$  is selected.

- Example of input capture operation setting procedure

Figure 11-12 shows an example of the input capture operation setting procedure.

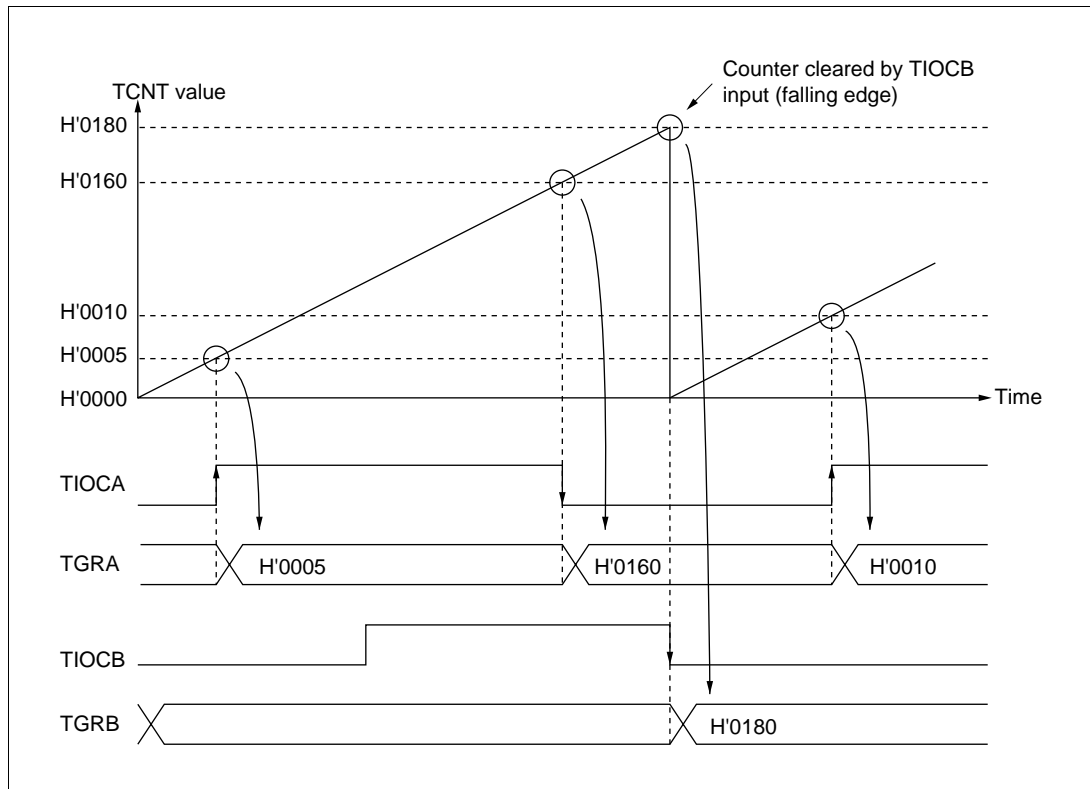


**Figure 11-12 Example of Input Capture Operation Setting Procedure**

- Example of input capture operation

Figure 11-13 shows an example of input capture operation.

In this example both rising and falling edges have been selected as the TIOCA pin input capture input edge, falling edge has been selected as the TIOCB pin input capture input edge, and counter clearing by TGRB input capture has been designated for TCNT.



**Figure 11-13 Example of Input Capture Operation**

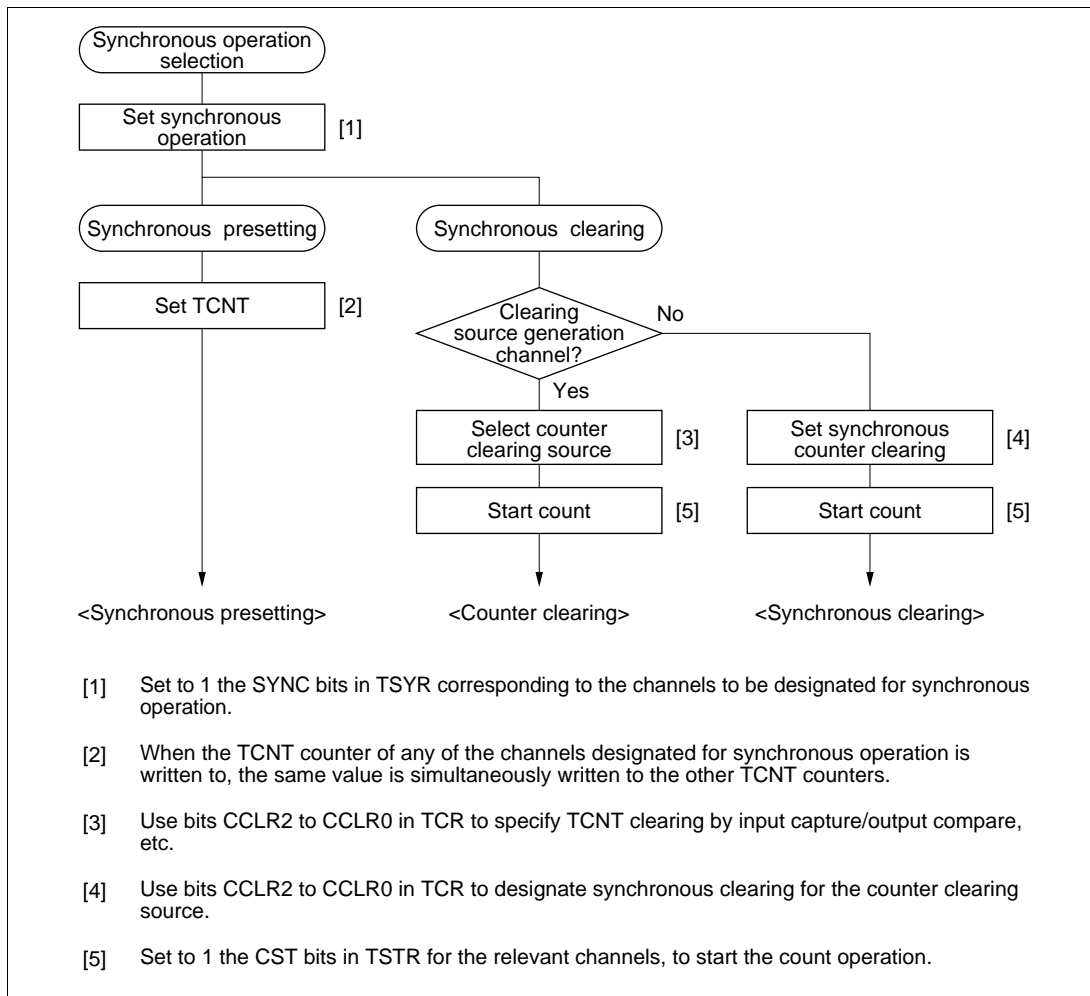
### 11.4.3 Synchronous Operation

In synchronous operation, the values in a number of TCNT counters can be rewritten simultaneously (synchronous presetting). Also, a number of TCNT counters can be cleared simultaneously by making the appropriate setting in TCR (synchronous clearing).

Synchronous operation enables TGR to be incremented with respect to a single time base.

Channels 0 to 5 can all be designated for synchronous operation.

**Example of Synchronous Operation Setting Procedure:** Figure 11-14 shows an example of the synchronous operation setting procedure.



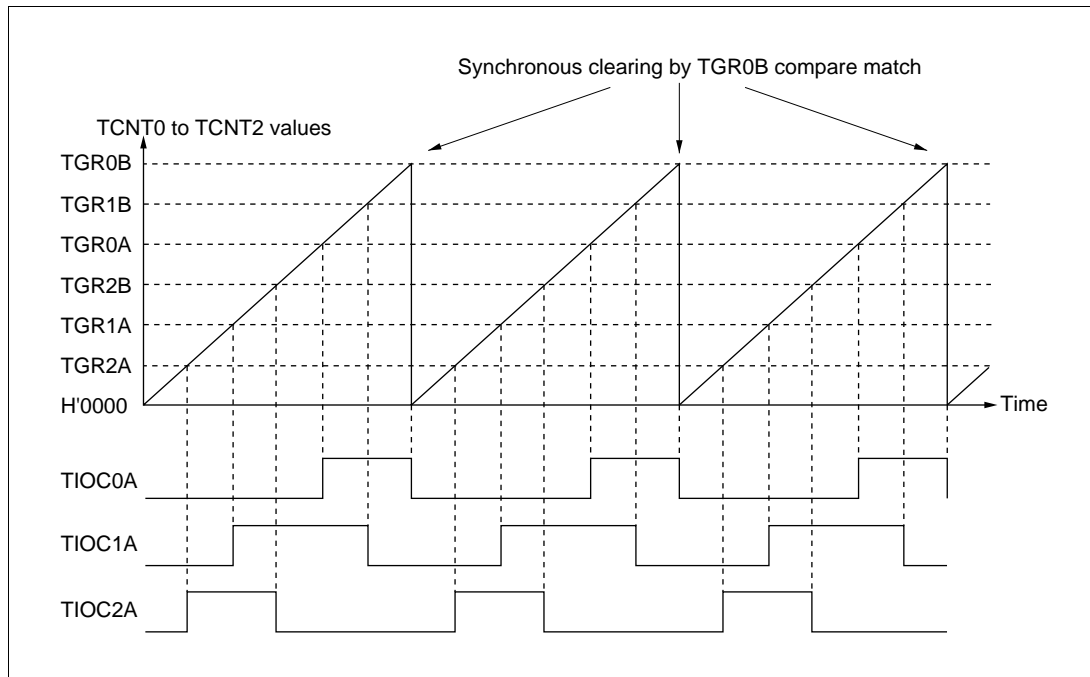
**Figure 11-14 Example of Synchronous Operation Setting Procedure**

**Example of Synchronous Operation:** Figure 11-15 shows an example of synchronous operation.

In this example, synchronous operation and PWM mode 1 have been designated for channels 0 to 2, TGR0B compare match has been set as the channel 0 counter clearing source, and synchronous clearing has been set for the channel 1 and 2 counter clearing source.

Three-phase PWM waveforms are output from pins TIOC0A, TIOC1A, and TIOC2A. At this time, synchronous presetting, and synchronous clearing by TGR0B compare match, is performed for channels 0 to 2 TCNT counters, and the data set in TGR0B is used as the PWM cycle.

For details of PWM modes, see section 11.4.6, PWM Modes.



**Figure 11-15 Example of Synchronous Operation**



#### 11.4.4 Buffer Operation

Buffer operation, provided for channels 0 and 3, enables TGRC and TGRD to be used as buffer registers.

Buffer operation differs depending on whether TGR has been designated as an input capture register or as a compare match register.

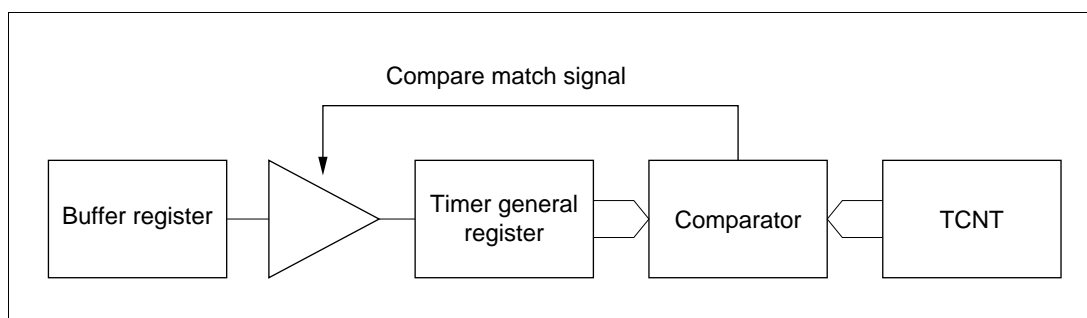
Table 11-5 shows the register combinations used in buffer operation.

**Table 11-5 Register Combinations in Buffer Operation**

Channel	Timer General Register	Buffer Register
0	TGR0A	TGR0C
	TGR0B	TGR0D
3	TGR3A	TGR3C
	TGR3B	TGR3D

- When TGR is an output compare register  
When a compare match occurs, the value in the buffer register for the corresponding channel is transferred to the timer general register.

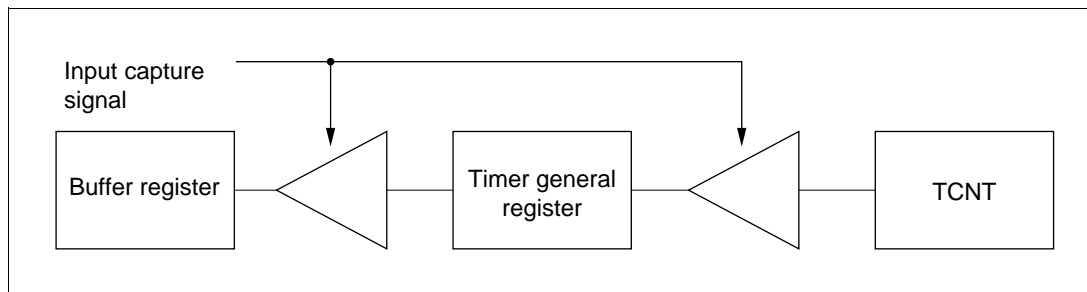
This operation is illustrated in figure 11-16.



**Figure 11-16 Compare Match Buffer Operation**

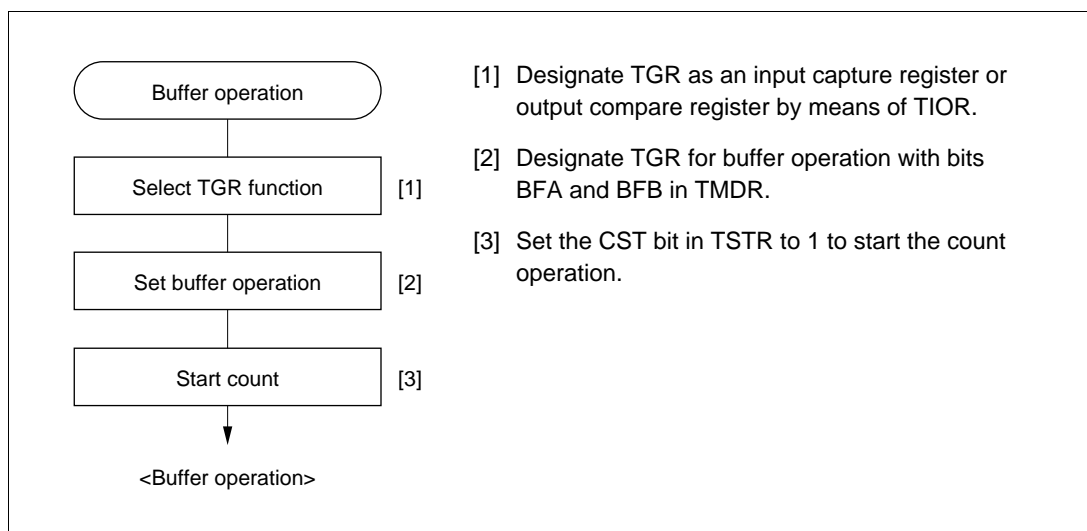
- When TGR is an input capture register  
When input capture occurs, the value in TCNT is transferred to TGR and the value previously held in the timer general register is transferred to the buffer register.

This operation is illustrated in figure 11-17.



**Figure 11-17 Input Capture Buffer Operation**

**Example of Buffer Operation Setting Procedure:** Figure 11-18 shows an example of the buffer operation setting procedure.



**Figure 11-18 Example of Buffer Operation Setting Procedure**

## Examples of Buffer Operation

- When TGR is an output compare register

Figure 11-19 shows an operation example in which PWM mode 1 has been designated for channel 0, and buffer operation has been designated for TGRA and TGRC. The settings used in this example are TCNT clearing by compare match B, 1 output at compare match A, and 0 output at compare match B.

As buffer operation has been set, when compare match A occurs the output changes and the value in buffer register TGRC is simultaneously transferred to timer general register TGRA. This operation is repeated each time compare match A occurs.

For details of PWM modes, see section 11.4.6, PWM Modes.

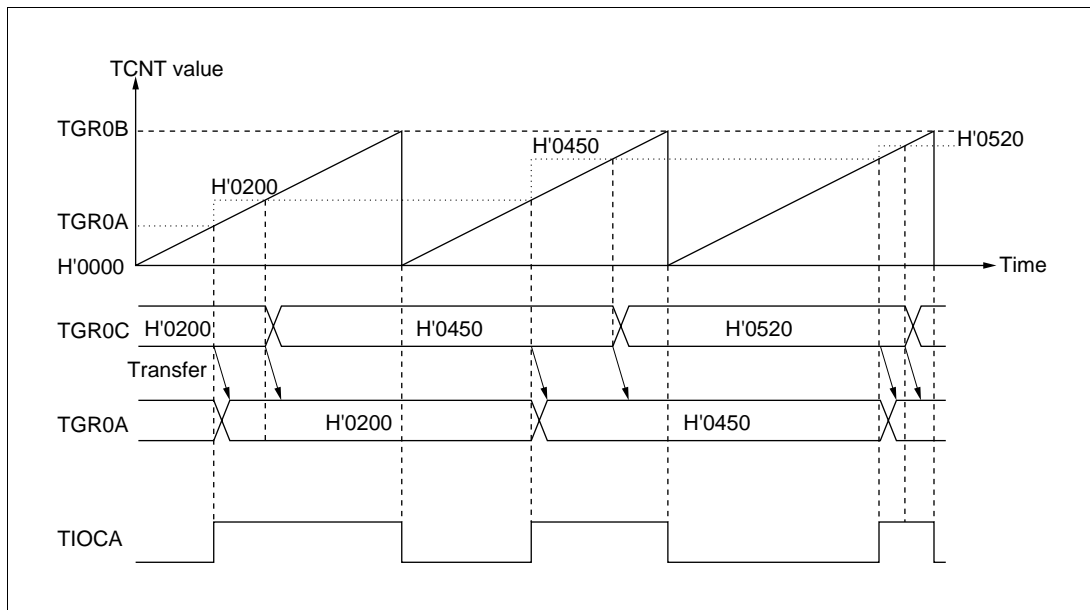


Figure 11-19 Example of Buffer Operation (1)

- When TGR is an input capture register

Figure 11-20 shows an operation example in which TGRA has been designated as an input capture register, and buffer operation has been designated for TGRA and TGRC.

Counter clearing by TGRA input capture has been set for TCNT, and both rising and falling edges have been selected as the TIOCA pin input capture input edge.

As buffer operation has been set, when the TCNT value is stored in TGRA upon occurrence of input capture A, the value previously stored in TGRA is simultaneously transferred to TGRC.

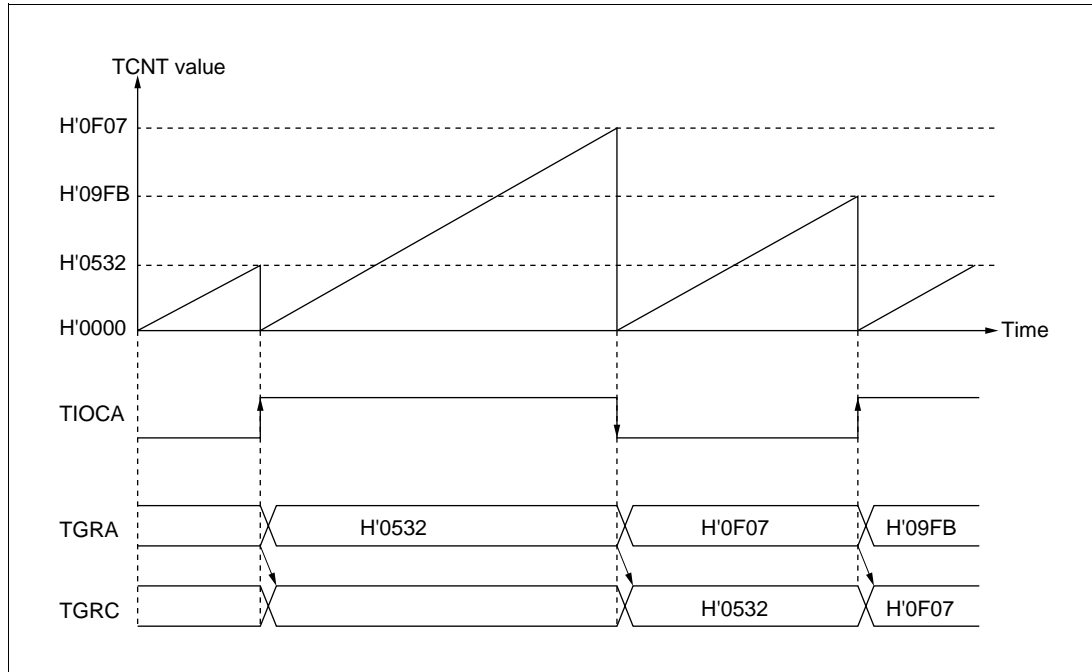


Figure 11-20 Example of Buffer Operation (2)

### 11.4.5 Cascaded Operation

In cascaded operation, two 16-bit counters for different channels are used together as a 32-bit counter.

This function works by counting the channel 1 (channel 4) counter clock upon overflow/underflow of TCNT2 (TCNT5) as set in bits TPSC2 to TPSC0 in TCR.

Underflow occurs only when the lower 16-bit TCNT is in phase-counting mode.

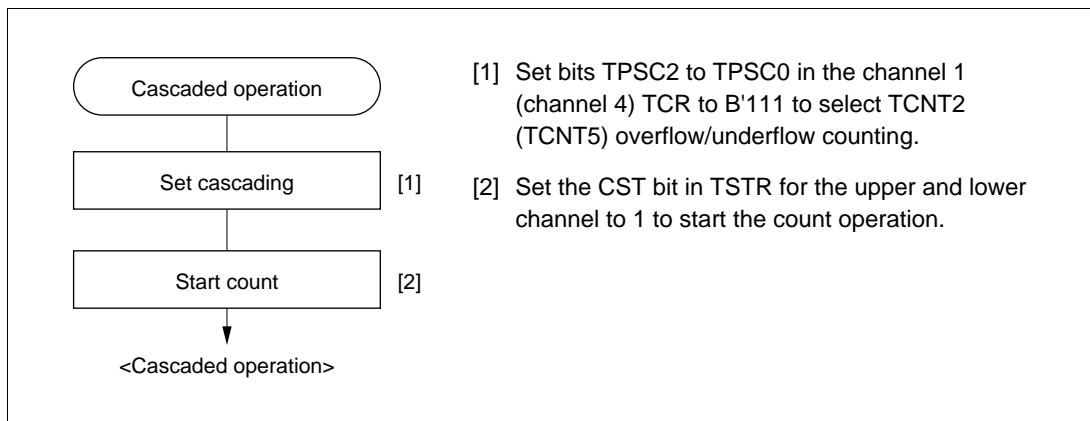
Table 11-6 shows the register combinations used in cascaded operation.

Note: When phase counting mode is set for channels 1 or 4, the counter clock setting is invalid and the counter operates independently in phase counting mode.

**Table 11-6 Cascaded Combinations**

Combination	Upper 16 Bits	Lower 16 Bits
Channels 1 and 2	TCNT1	TCNT2
Channels 4 and 5	TCNT4	TCNT5

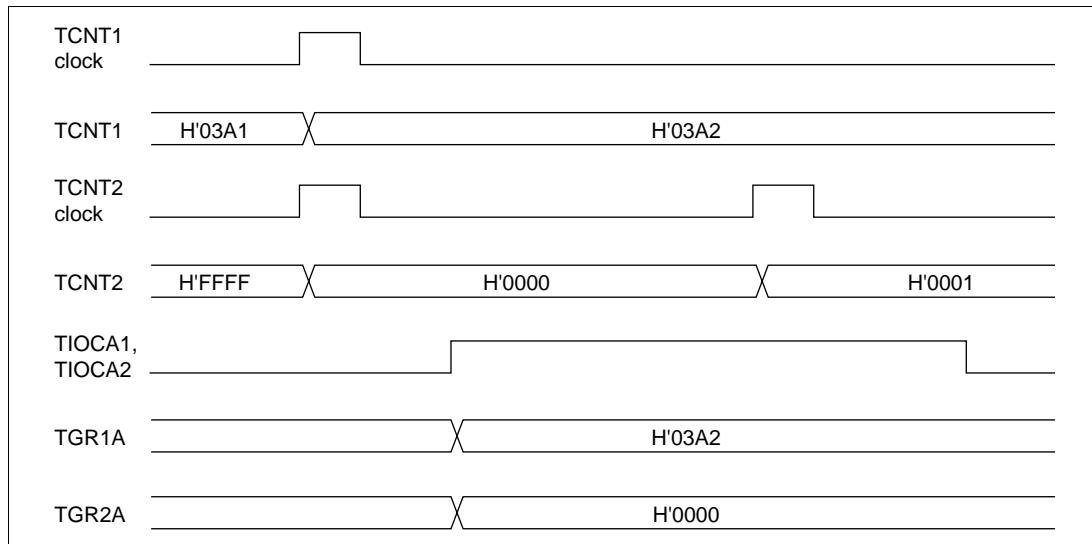
**Example of Cascaded Operation Setting Procedure:** Figure 11-21 shows an example of the setting procedure for cascaded operation.



**Figure 11-21 Cascaded Operation Setting Procedure**

**Examples of Cascaded Operation:** Figure 11-22 illustrates the operation when counting upon TCNT2 overflow/underflow has been set for TCNT1, TGR1A and TGR2A have been designated as input capture registers, and TIOC pin rising edge has been selected.

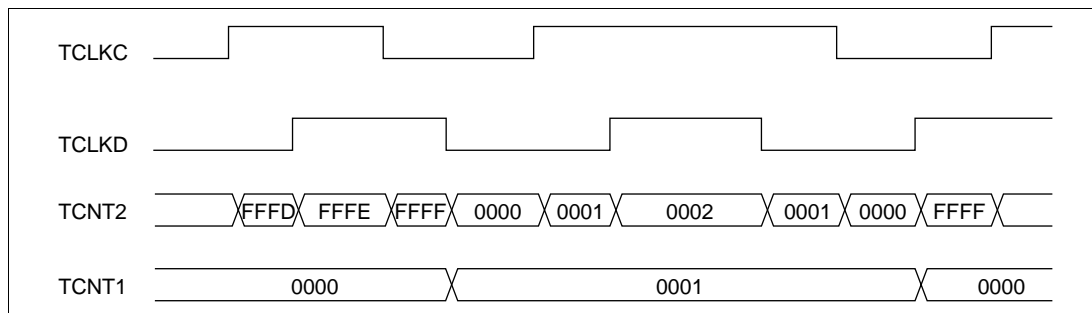
When a rising edge is input to the TIOCA1 and TIOCA2 pins simultaneously, the upper 16 bits of the 32-bit data are transferred to TGR1A, and the lower 16 bits to TGR2A.



**Figure 11-22 Example of Cascaded Operation (1)**

Figure 11-23 illustrates the operation when counting upon TCNT2 overflow/underflow has been set for TCNT1, and phase counting mode has been designated for channel 2.

TCNT1 is incremented by TCNT2 overflow and decremented by TCNT2 underflow.



**Figure 11-23 Example of Cascaded Operation (2)**

#### 11.4.6 PWM Modes

In PWM mode, PWM waveforms are output from the output pins. 0, 1, or toggle output can be selected as the output level in response to compare match of each TGR.

Designating TGR compare match as the counter clearing source enables the period to be set in that register. All channels can be designated for PWM mode independently. Synchronous operation is also possible.

There are two PWM modes, as described below.

- PWM mode 1

PWM output is generated from the TIOCA and TIOCC pins by pairing TGRA with TGRB and TGRC with TGRD. The output specified by bits IOA3 to IOA0 and IOC3 to IOC0 in TIOR is output from the TIOCA and TIOCC pins at compare matches A and C, and the output specified by bits IOB3 to IOB0 and IOD3 to IOD0 in TIOR is output at compare matches B and D. The initial output value is the value set in TGRA or TGRC. If the set values of paired TGRs are identical, the output value does not change when a compare match occurs.

In PWM mode 1, a maximum 8-phase PWM output is possible.

- PWM mode 2

PWM output is generated using one TGR as the cycle register and the others as duty registers. The output specified in TIOR is performed by means of compare matches. Upon counter clearing by a synchronization register compare match, the output value of each pin is the initial value set in TIOR. If the set values of the cycle and duty registers are identical, the output value does not change when a compare match occurs.

In PWM mode 2, a maximum 15-phase PWM output is possible by combined use with synchronous operation.

The correspondence between PWM output pins and registers is shown in table 11-7.

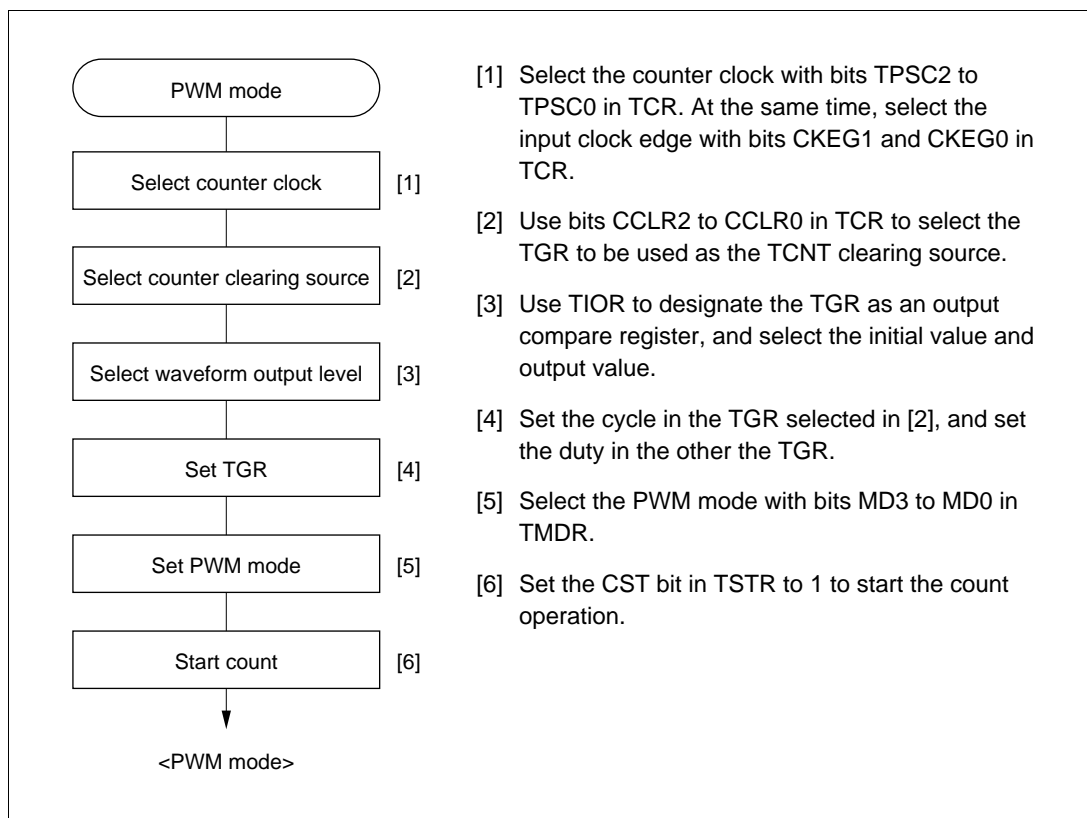
**Table 11-7 PWM Output Registers and Output Pins**

Channel	Registers	Output Pins	
		PWM Mode 1	PWM Mode 2
0	TGR0A	TIOCA0	TIOCA0
	TGR0B		TIOCB0
	TGR0C	TIOCC0	TIOCC0
	TGR0D		TIOCD0
1	TGR1A	TIOCA1	TIOCA1
	TGR1B		TIOCB1
2	TGR2A	TIOCA2	TIOCA2
	TGR2B		TIOCB2
3	TGR3A	TIOCA3	TIOCA3
	TGR3B		TIOCB3
	TGR3C	TIOCC3	TIOCC3
	TGR3D		TIOCD3
4	TGR4A	TIOCA4	TIOCA4
	TGR4B		TIOCB4
5	TGR5A	TIOCA5	TIOCA5
	TGR5B		TIOCB5

Note: In PWM mode 2, PWM output is not possible for the TGR register in which the period is set.



**Example of PWM Mode Setting Procedure:** Figure 11-24 shows an example of the PWM mode setting procedure.

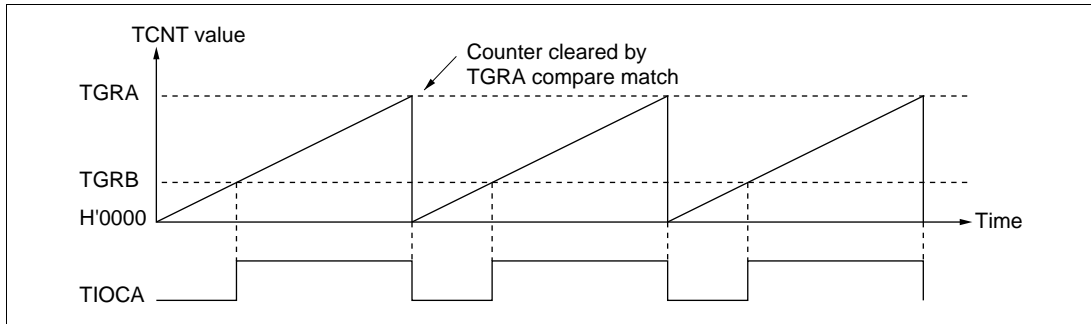


**Figure 11-24 Example of PWM Mode Setting Procedure**

**Examples of PWM Mode Operation:** Figure 11-25 shows an example of PWM mode 1 operation.

In this example, TGRA compare match is set as the TCNT clearing source, 0 is set for the TGRA initial output value and output value, and 1 is set as the TGRB output value.

In this case, the value set in TGRA is used as the period, and the values set in TGRB registers as the duty.

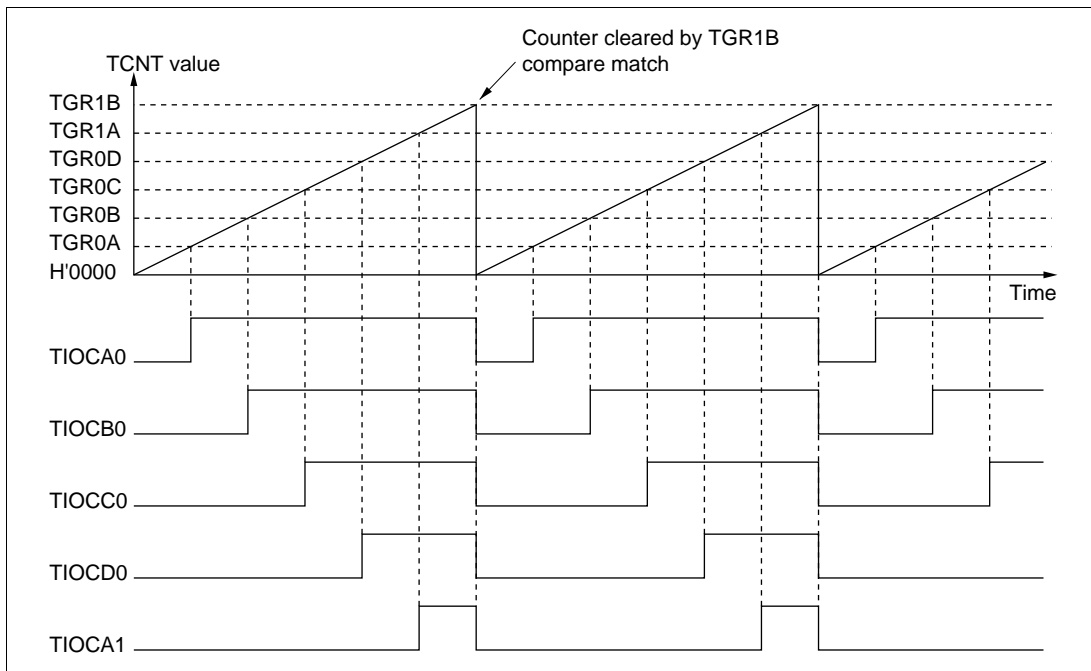


**Figure 11-25 Example of PWM Mode Operation (1)**

Figure 11-26 shows an example of PWM mode 2 operation.

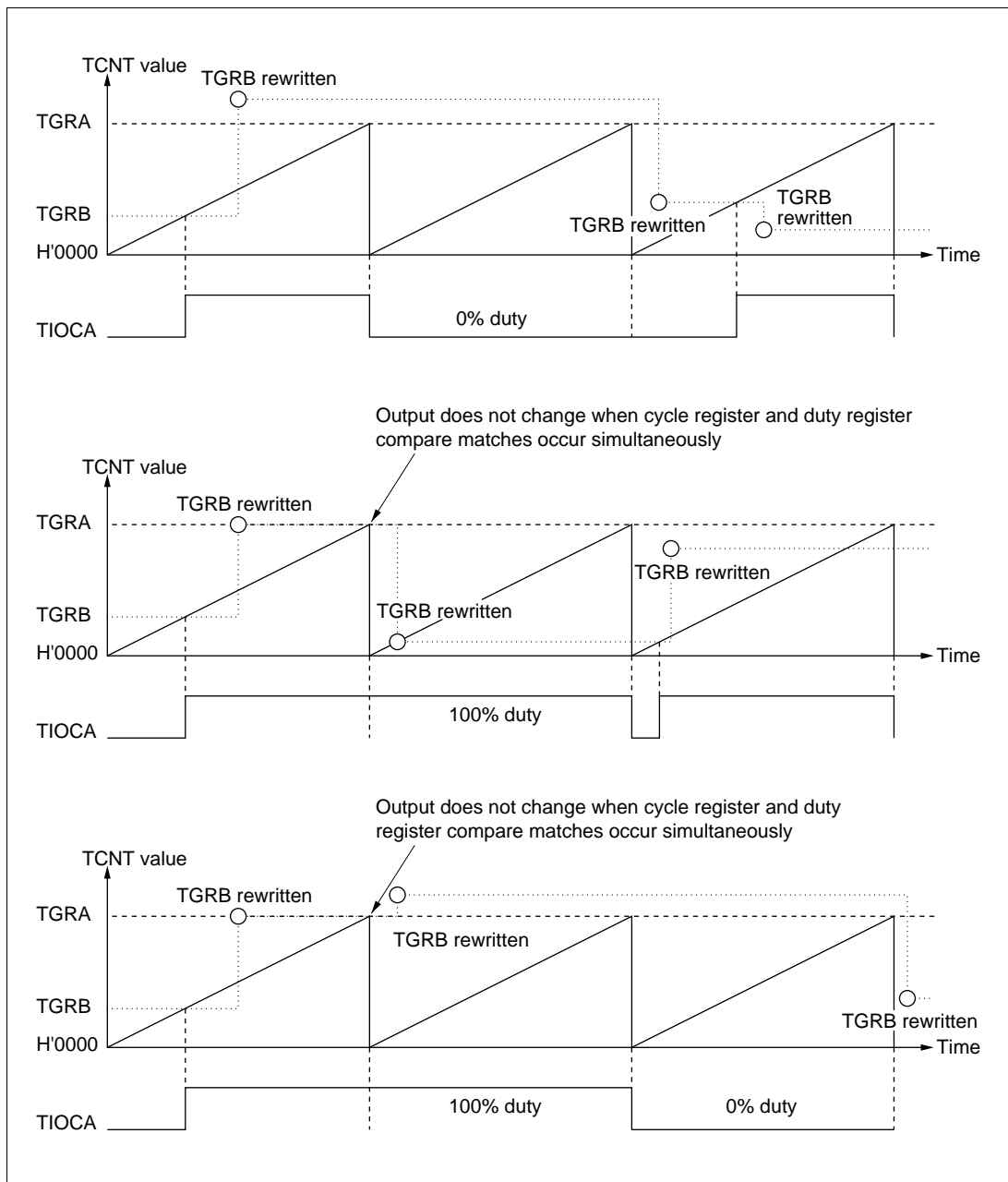
In this example, synchronous operation is designated for channels 0 and 1, TGR1B compare match is set as the TCNT clearing source, and 0 is set for the initial output value and 1 for the output value of the other TGR registers (TGR0A to TGR0D, TGR1A), to output a 5-phase PWM waveform.

In this case, the value set in TGR1B is used as the cycle, and the values set in the other TGRs as the duty.



**Figure 11-26 Example of PWM Mode Operation (2)**

Figure 11-27 shows examples of PWM waveform output with 0% duty and 100% duty in PWM mode.



**Figure 11-27 Example of PWM Mode Operation (3)**

### 11.4.7 Phase Counting Mode

In phase counting mode, the phase difference between two external clock inputs is detected and TCNT is incremented/decremented accordingly. This mode can be set for channels 1, 2, 4, and 5.

When phase counting mode is set, an external clock is selected as the counter input clock and TCNT operates as an up/down-counter regardless of the setting of bits TPSC2 to TPSC0 and bits CKEG1 and CKEG0 in TCR. However, the functions of bits CCLR1 and CCLR0 in TCR, and of TIOR, TIER, and TGR are valid, and input capture/compare match and interrupt functions can be used.

When overflow occurs while TCNT is counting up, the TCFV flag in TSR is set; when underflow occurs while TCNT is counting down, the TCFU flag is set.

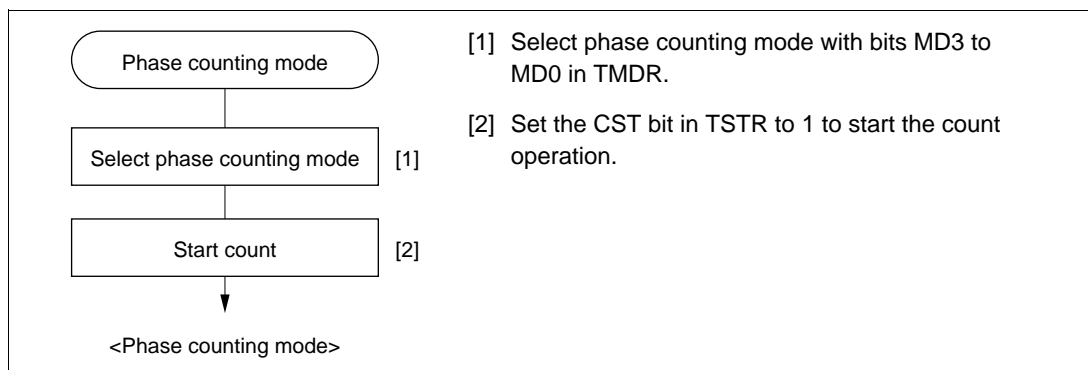
The TCFD bit in TSR is the count direction flag. Reading the TCFD flag provides an indication of whether TCNT is counting up or down.

Table 11-8 shows the correspondence between external clock pins and channels.

**Table 11-8 Phase Counting Mode Clock Input Pins**

Channels	External Clock Pins	
	A-Phase	B-Phase
When channel 1 or 5 is set to phase counting mode	TCLKA	TCLKB
When channel 2 or 4 is set to phase counting mode	TCLKC	TCLKD

**Example of Phase Counting Mode Setting Procedure:** Figure 11-28 shows an example of the phase counting mode setting procedure.

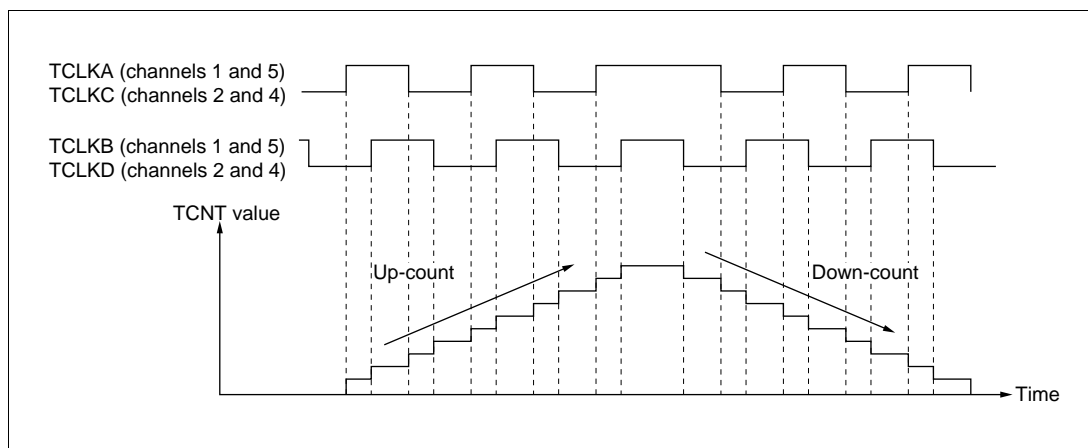


**Figure 11-28 Example of Phase Counting Mode Setting Procedure**

**Examples of Phase Counting Mode Operation:** In phase counting mode, TCNT counts up or down according to the phase difference between two external clocks. There are four modes, according to the count conditions.

- Phase counting mode 1

Figure 11-29 shows an example of phase counting mode 1 operation, and table 11-9 summarizes the TCNT up/down-count conditions.



**Figure 11-29 Example of Phase Counting Mode 1 Operation**

**Table 11-9 Up/Down-Count Conditions in Phase Counting Mode 1**

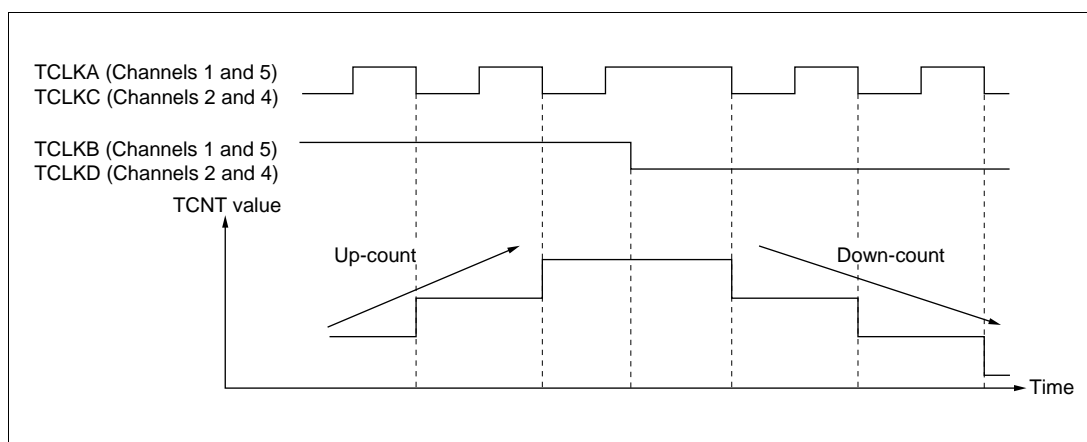
TCLKA (Channels 1 and 5) TCLKC (Channels 2 and 4)	TCLKB (Channels 1 and 5) TCLKD (Channels 2 and 4)	Operation
High level		Up-count
Low level		
	Low level	
	High level	
High level		Down-count
Low level		
	High level	
	Low level	

**Legend**

- : Rising edge
- : Falling edge

- Phase counting mode 2

Figure 11-30 shows an example of phase counting mode 2 operation, and table 11-10 summarizes the TCNT up/down-count conditions.



**Figure 11-30 Example of Phase Counting Mode 2 Operation**

**Table 11-10 Up/Down-Count Conditions in Phase Counting Mode 2**

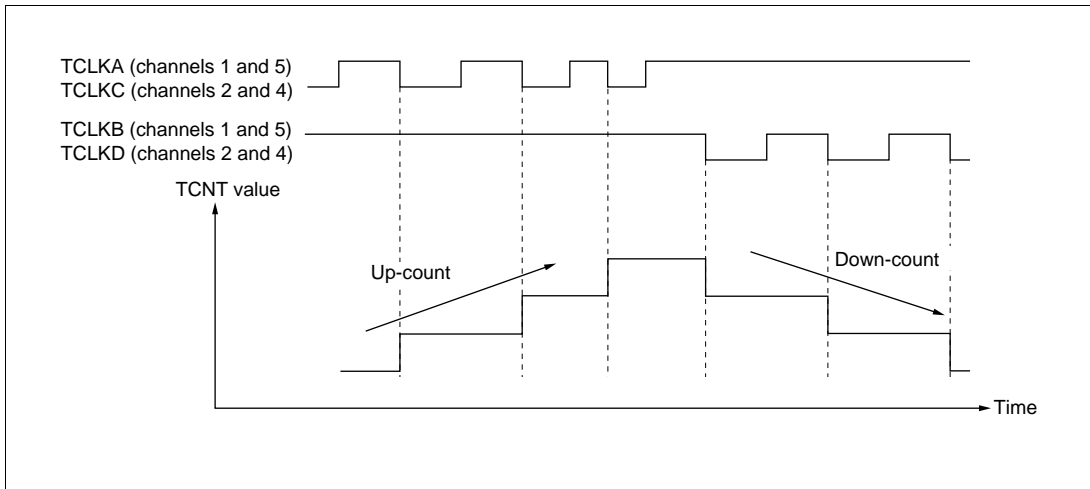
TCLKA (Channels 1 and 5) TCLKC (Channels 2 and 4)	TCLKB (Channels 1 and 5) TCLKD (Channels 2 and 4)	Operation
High level	$\uparrow$	Don't care
Low level	$\downarrow$	Don't care
$\uparrow$	Low level	Don't care
$\downarrow$	High level	Up-count
High level	$\downarrow$	Don't care
Low level	$\uparrow$	Don't care
$\uparrow$	High level	Don't care
$\downarrow$	Low level	Down-count

**Legend**

- $\uparrow$  : Rising edge
- $\downarrow$  : Falling edge

- Phase counting mode 3

Figure 11-31 shows an example of phase counting mode 3 operation, and table 11-11 summarizes the TCNT up/down-count conditions.



**Figure 11-31 Example of Phase Counting Mode 3 Operation**

**Table 11-11 Up/Down-Count Conditions in Phase Counting Mode 3**

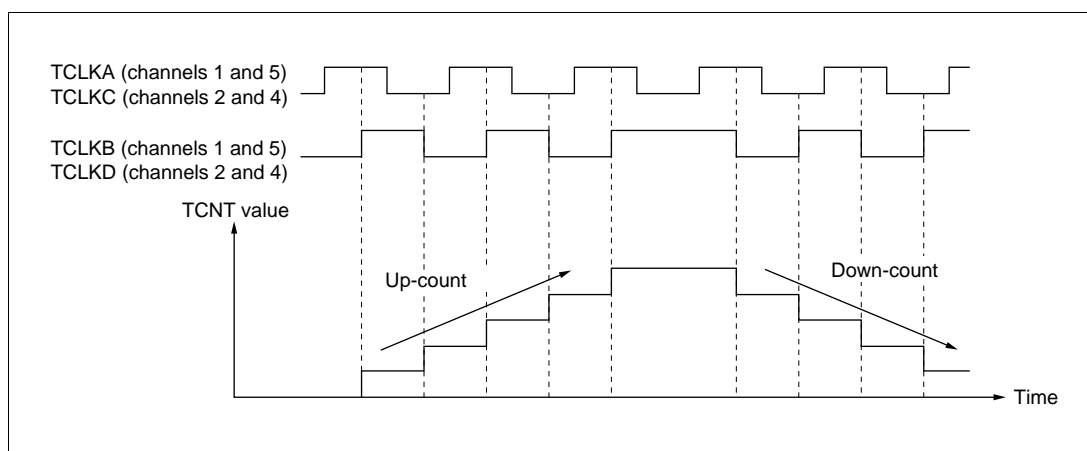
TCLKA (Channels 1 and 5) TCLKC (Channels 2 and 4)	TCLKB (Channels 1 and 5) TCLKD (Channels 2 and 4)	Operation
High level	┌	Don't care
Low level	└	Don't care
┌	Low level	Don't care
└	High level	Up-count
High level	└	Down-count
Low level	┌	Don't care
┌	High level	Don't care
└	Low level	Don't care

**Legend**

- ┌ : Rising edge
- └ : Falling edge

- Phase counting mode 4

Figure 11-32 shows an example of phase counting mode 4 operation, and table 11-12 summarizes the TCNT up/down-count conditions.



**Figure 11-32 Example of Phase Counting Mode 4 Operation**

**Table 11-12 Up/Down-Count Conditions in Phase Counting Mode 4**

TCLKA (Channels 1 and 5) TCLKC (Channels 2 and 4)	TCLKB (Channels 1 and 5) TCLKD (Channels 2 and 4)	Operation
High level	┌	Up-count
Low level	└	Up-count
┌	Low level	Don't care
└	High level	Don't care
High level	└	Down-count
Low level	┌	Down-count
┌	High level	Don't care
└	Low level	Don't care

**Legend**

- ┌ : Rising edge
- └ : Falling edge



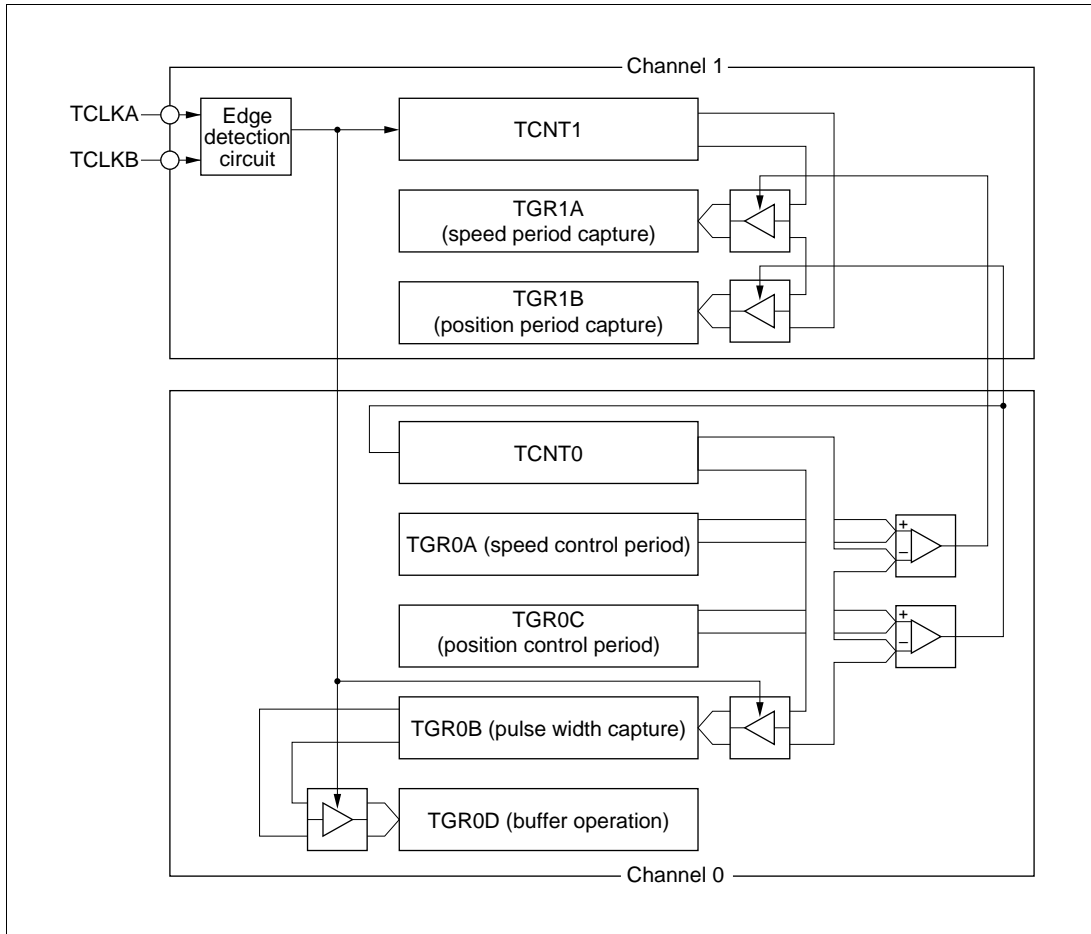
**Phase Counting Mode Application Example:** Figure 11-33 shows an example in which phase counting mode is designated for channel 1, and channel 1 is coupled with channel 0 to input servo motor 2-phase encoder pulses in order to detect the position or speed.

Channel 1 is set to phase counting mode 1, and the encoder pulse A-phase and B-phase are input to TCLKA and TCLKB.

Channel 0 operates with TCNT counter clearing by TGR0C compare match; TGR0A and TGR0C are used for the compare match function, and are set with the speed control period and position control period. TGR0B is used for input capture, with TGR0B and TGR0D operating in buffer mode. The channel 1 counter input clock is designated as the TGR0B input capture source, and detection of the pulse width of 2-phase encoder 4-multiplication pulses is performed.

TGR1A and TGR1B for channel 1 are designated for input capture, channel 0 TGR0A and TGR0C compare matches are selected as the input capture source, and store the up/down-counter values for the control periods.

This procedure enables accurate position/speed detection to be achieved.



**Figure 11-33 Phase Counting Mode Application Example**

## 11.5 Interrupts

### 11.5.1 Interrupt Sources and Priorities

There are three kinds of TPU interrupt source: TGR input capture/compare match, TCNT overflow, and TCNT underflow. Each interrupt source has its own status flag and enable/disabled bit, allowing generation of interrupt request signals to be enabled or disabled individually.

When an interrupt request is generated, the corresponding status flag in TSR is set to 1. If the corresponding enable/disable bit in TIER is set to 1 at this time, an interrupt is requested. The interrupt request is cleared by clearing the status flag to 0.

Relative channel priorities can be changed by the interrupt controller, but the priority order within a channel is fixed. For details, see section 5, Interrupt Controller.

Table 11-13 lists the TPU interrupt sources.

**Table 11-13 TPU Interrupts**

Channel	Interrupt Source	Description	DMAC* Activation	DTC* Activation	Priority
0	TGI0A	TGR0A input capture/compare match	Possible	Possible	High ↑
	TGI0B	TGR0B input capture/compare match	Not possible	Possible	
	TGI0C	TGR0C input capture/compare match	Not possible	Possible	
	TGI0D	TGR0D input capture/compare match	Not possible	Possible	
	TCI0V	TCNT0 overflow	Not possible	Not possible	
1	TGI1A	TGR1A input capture/compare match	Possible	Possible	↓
	TGI1B	TGR1B input capture/compare match	Not possible	Possible	
	TCI1V	TCNT1 overflow	Not possible	Not possible	
	TCI1U	TCNT1 underflow	Not possible	Not possible	
2	TGI2A	TGR2A input capture/compare match	Possible	Possible	
	TGI2B	TGR2B input capture/compare match	Not possible	Possible	
	TCI2V	TCNT2 overflow	Not possible	Not possible	
	TCI2U	TCNT2 underflow	Not possible	Not possible	
3	TGI3A	TGR3A input capture/compare match	Possible	Possible	
	TGI3B	TGR3B input capture/compare match	Not possible	Possible	
	TGI3C	TGR3C input capture/compare match	Not possible	Possible	
	TGI3D	TGR3D input capture/compare match	Not possible	Possible	
	TCI3V	TCNT3 overflow	Not possible	Not possible	
4	TGI4A	TGR4A input capture/compare match	Possible	Possible	
	TGI4B	TGR4B input capture/compare match	Not possible	Possible	
	TCI4V	TCNT4 overflow	Not possible	Not possible	
	TCI4U	TCNT4 underflow	Not possible	Not possible	
5	TGI5A	TGR5A input capture/compare match	Possible	Possible	Low
	TGI5B	TGR5B input capture/compare match	Not possible	Possible	
	TCI5V	TCNT5 overflow	Not possible	Not possible	
	TCI5U	TCNT5 underflow	Not possible	Not possible	

Notes: This table shows the initial state immediately after a reset. The relative channel priorities can be changed by the interrupt controller.

\* DMAC and DTC functions are not available in the H8S/2695.

**Input Capture/Compare Match Interrupt:** An interrupt is requested if the TGIE bit in TIER is set to 1 when the TGF flag in TSR is set to 1 by the occurrence of a TGR input capture/compare match on a particular channel. The interrupt request is cleared by clearing the TGF flag to 0. The TPU has 16 input capture/compare match interrupts, four each for channels 0 and 3, and two each for channels 1, 2, 4, and 5.

**Overflow Interrupt:** An interrupt is requested if the TCIEV bit in TIER is set to 1 when the TCFV flag in TSR is set to 1 by the occurrence of TCNT overflow on a channel. The interrupt request is cleared by clearing the TCFV flag to 0. The TPU has six overflow interrupts, one for each channel.

**Underflow Interrupt:** An interrupt is requested if the TCIEU bit in TIER is set to 1 when the TCFU flag in TSR is set to 1 by the occurrence of TCNT underflow on a channel. The interrupt request is cleared by clearing the TCFU flag to 0. The TPU has four underflow interrupts, one each for channels 1, 2, 4, and 5.

### 11.5.2 DTC/DMAC Activation (This function is not available in the H8S/2695)

**DTC Activation:** The DTC can be activated by the TGR input capture/compare match interrupt for a channel. For details, see section 9, Data Transfer Controller (DTC).

A total of 16 TPU input capture/compare match interrupts can be used as DTC activation sources, four each for channels 0 and 3, and two each for channels 1, 2, 4, and 5.

**DMAC Activation:** It is possible to activate the DMAC by the TGRA input capture/compare match interrupt for each channel. See section 8, DMA Controller (DMAC) for details.

In TPU, it is possible to set the TGRA input capture/compare match interrupts for each channel, giving a total of 6, as DMAC activation factors.

### 11.5.3 A/D Converter Activation

The A/D converter can be activated by the TGRA input capture/compare match for a channel.

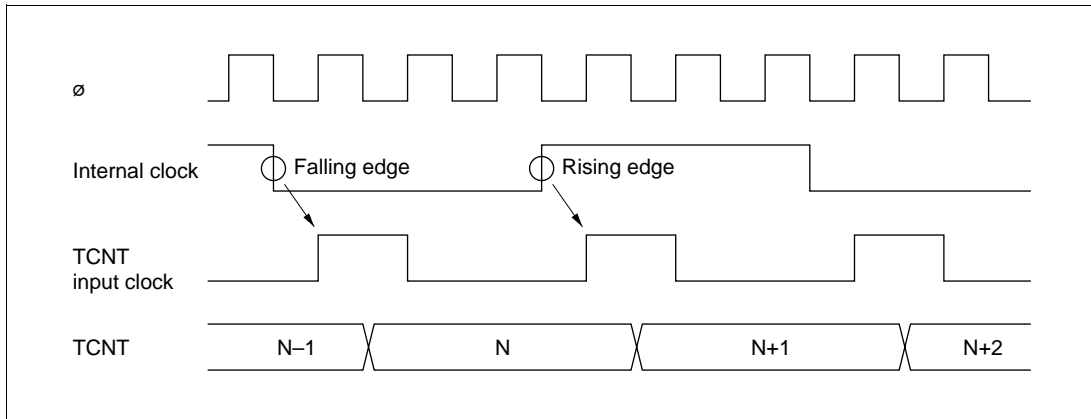
If the TTGE bit in TIER is set to 1 when the TGFA flag in TSR is set to 1 by the occurrence of a TGRA input capture/compare match on a particular channel, a request to start A/D conversion is sent to the A/D converter. If the TPU conversion start trigger has been selected on the A/D converter side at this time, A/D conversion is started.

In the TPU, a total of six TGRA input capture/compare match interrupts can be used as A/D converter conversion start sources, one for each channel.

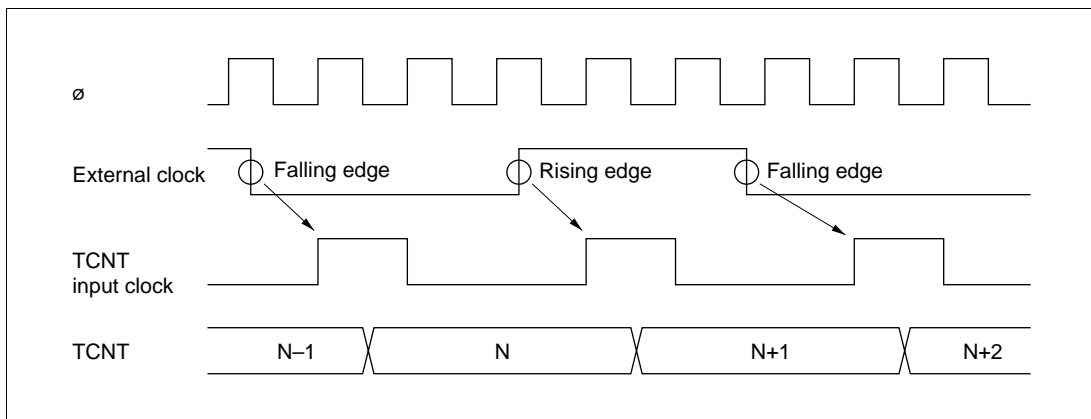
## 11.6 Operation Timing

### 11.6.1 Input/Output Timing

**TCNT Count Timing:** Figure 11-34 shows TCNT count timing in internal clock operation, and figure 11-35 shows TCNT count timing in external clock operation.



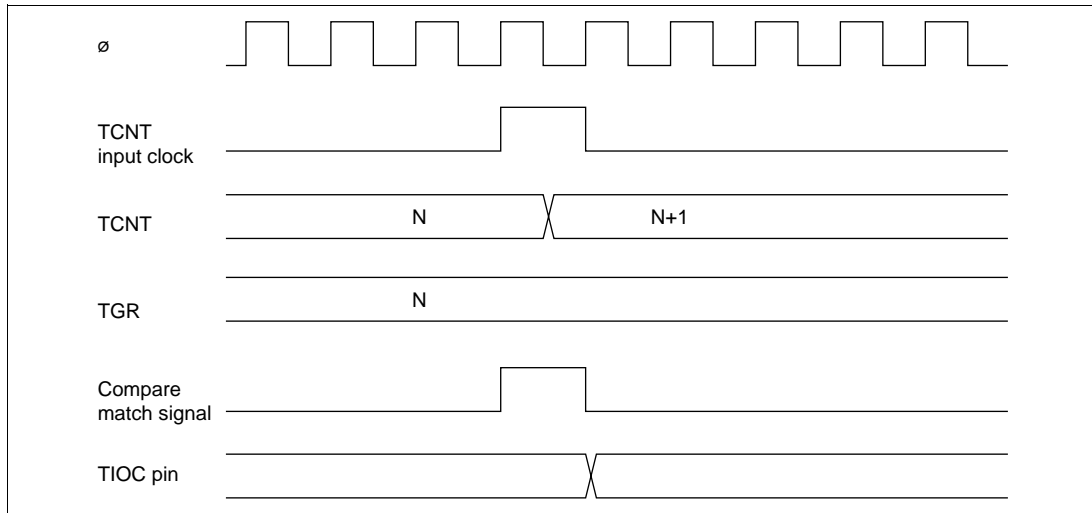
**Figure 11-34 Count Timing in Internal Clock Operation**



**Figure 11-35 Count Timing in External Clock Operation**

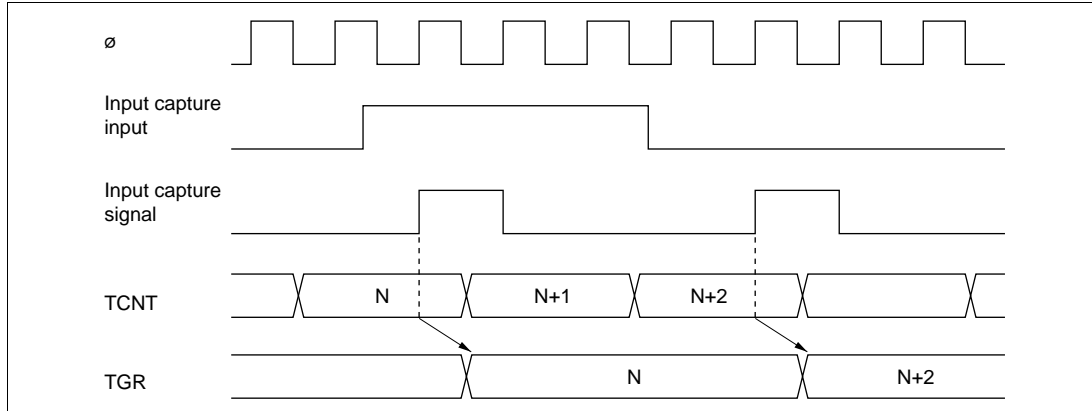
**Output Compare Output Timing:** A compare match signal is generated in the final state in which TCNT and TGR match (the point at which the count value matched by TCNT is updated). When a compare match signal is generated, the output value set in TIOR is output at the output compare output pin (TIOC pin). After a match between TCNT and TGR, the compare match signal is not generated until the TCNT input clock is generated.

Figure 11-36 shows output compare output timing.



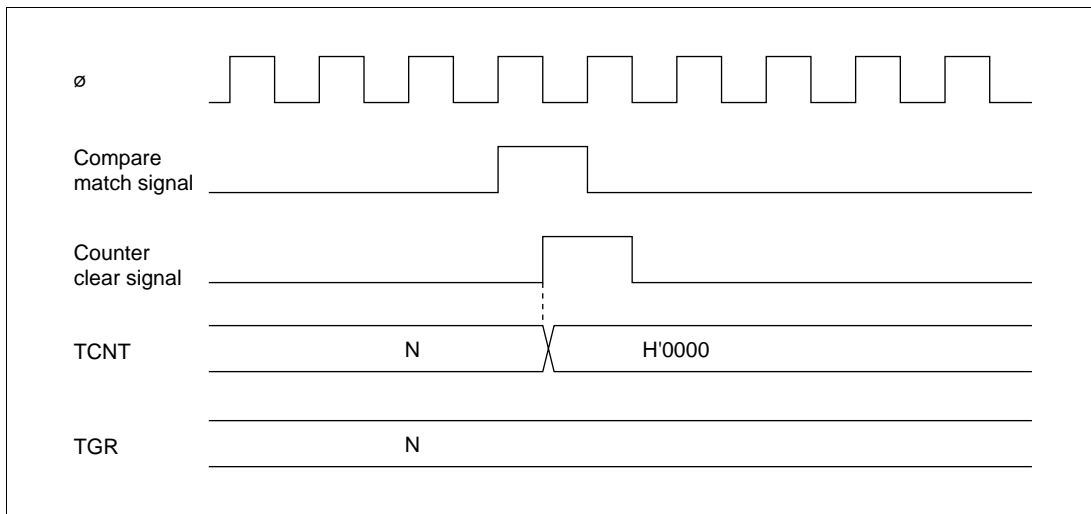
**Figure 11-36 Output Compare Output Timing**

**Input Capture Signal Timing:** Figure 11-37 shows input capture signal timing.

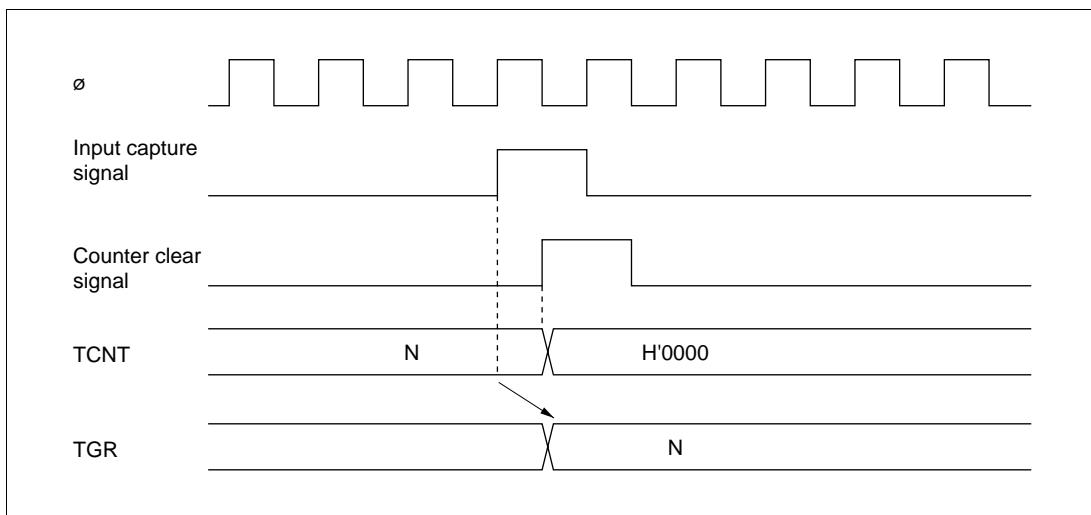


**Figure 11-37 Input Capture Input Signal Timing**

**Timing for Counter Clearing by Compare Match/Input Capture:** Figure 11-38 shows the timing when counter clearing by compare match occurrence is specified, and figure 11-39 shows the timing when counter clearing by input capture occurrence is specified.



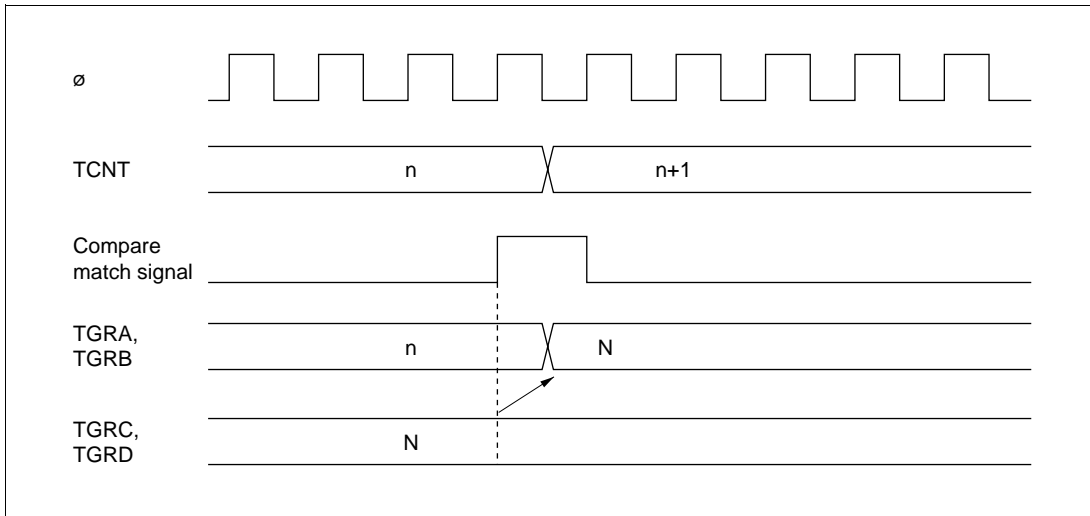
**Figure 11-38 Counter Clear Timing (Compare Match)**



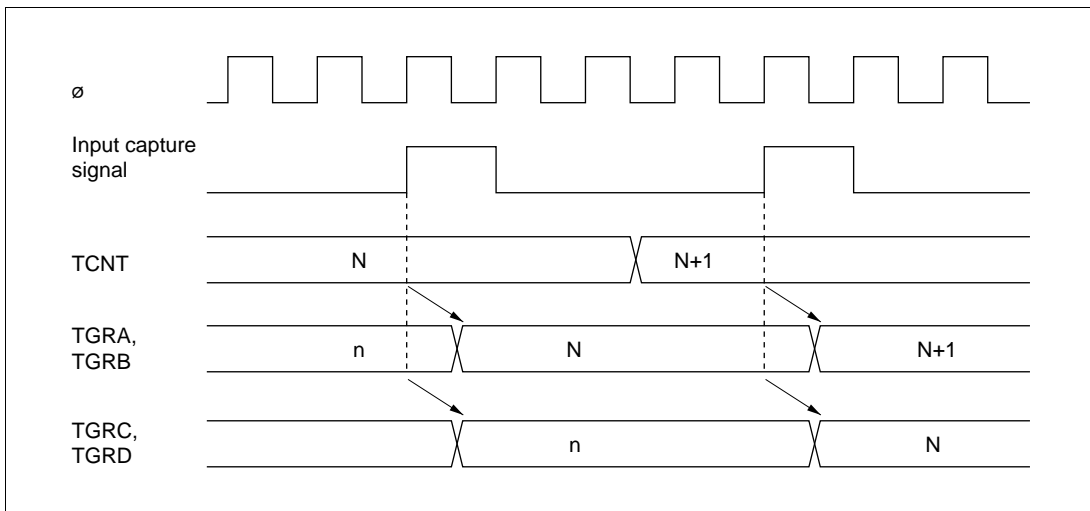
**Figure 11-39 Counter Clear Timing (Input Capture)**



**Buffer Operation Timing:** Figures 11-40 and 11-41 show the timing in buffer operation.



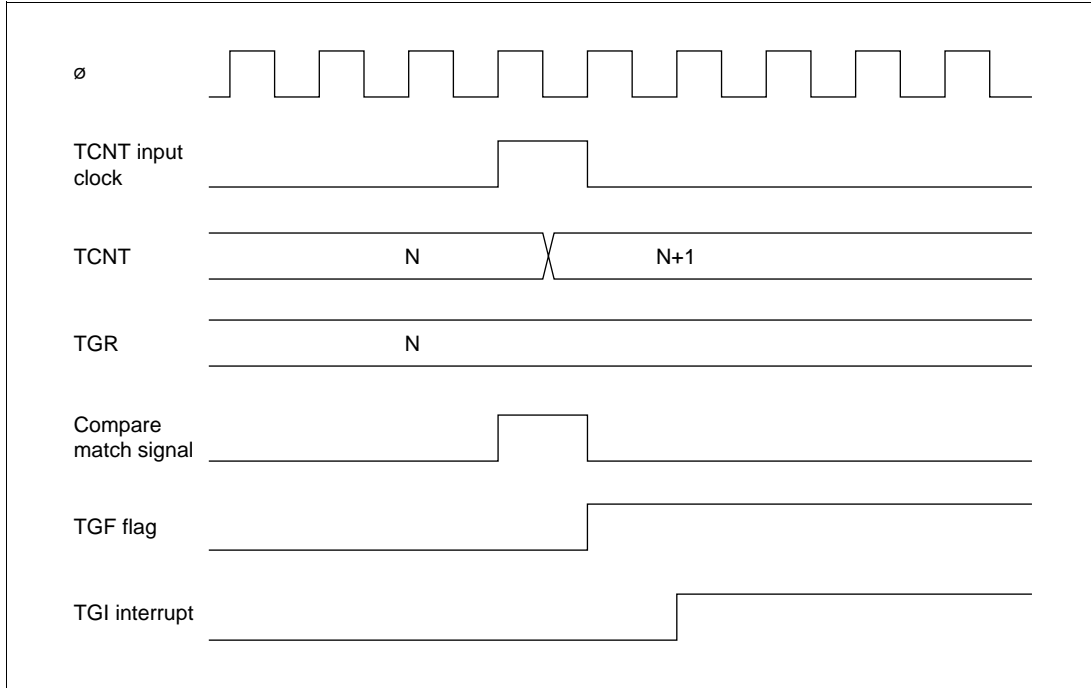
**Figure 11-40 Buffer Operation Timing (Compare Match)**



**Figure 11-41 Buffer Operation Timing (Input Capture)**

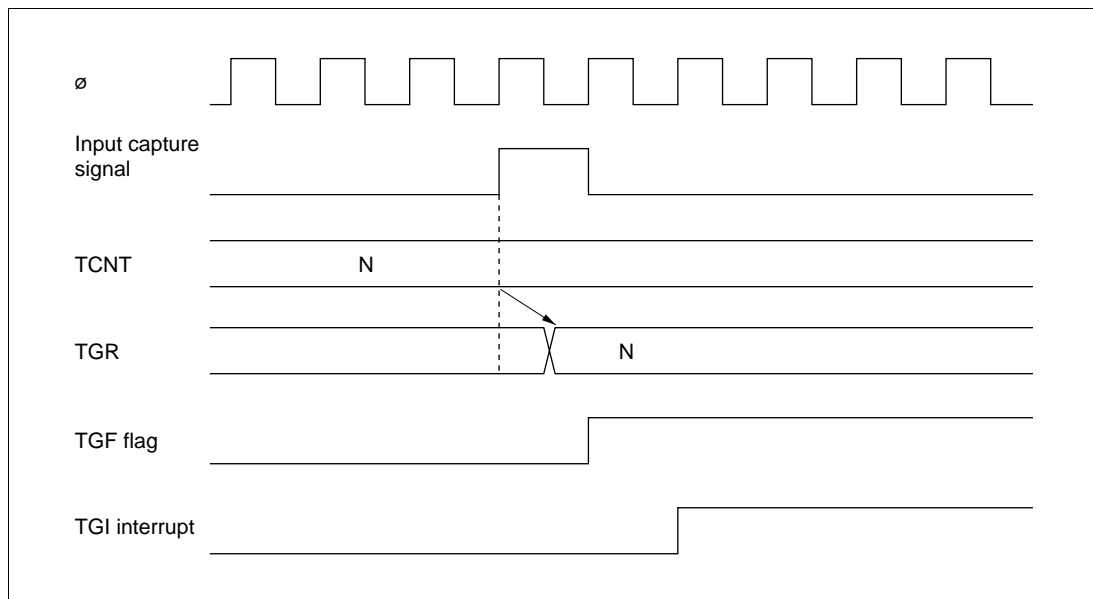
### 11.6.2 Interrupt Signal Timing

**TGF Flag Setting Timing in Case of Compare Match:** Figure 11-42 shows the timing for setting of the TGF flag in TSR by compare match occurrence, and TGI interrupt request signal timing.



**Figure 11-42 TGI Interrupt Timing (Compare Match)**

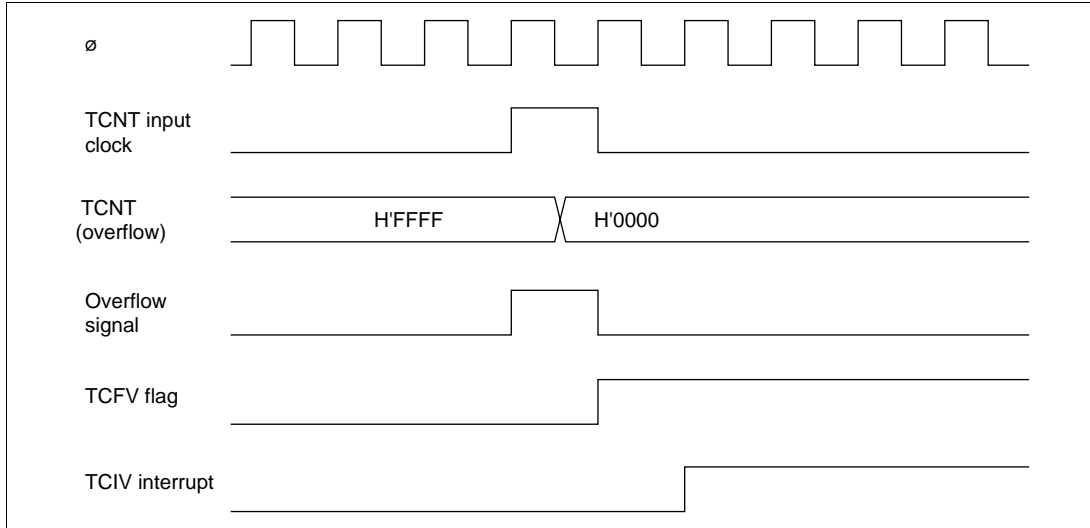
**TGF Flag Setting Timing in Case of Input Capture:** Figure 11-43 shows the timing for setting of the TGF flag in TSR by input capture occurrence, and TGI interrupt request signal timing.



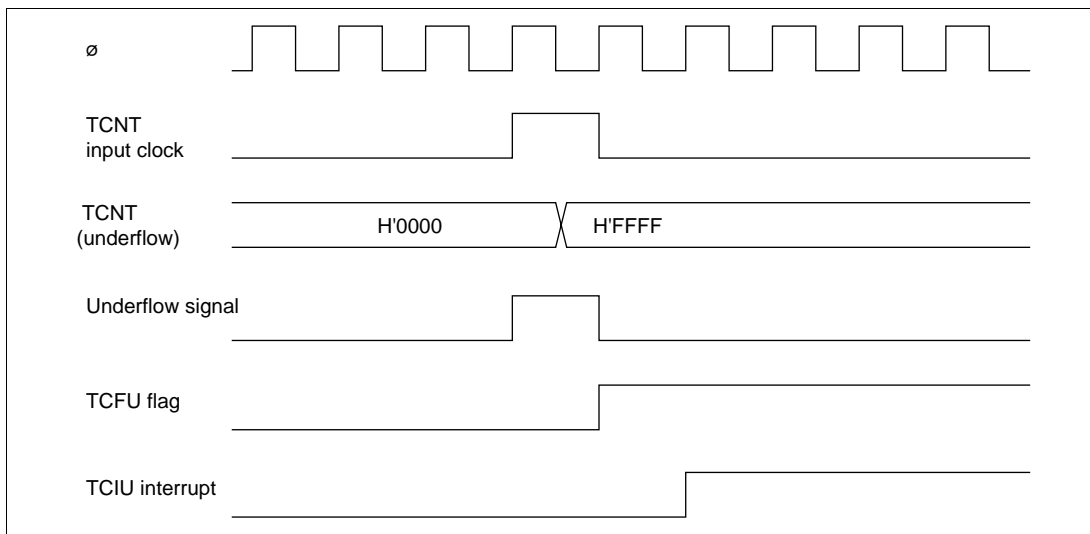
**Figure 11-43 TGI Interrupt Timing (Input Capture)**

**TCFV Flag/TCFU Flag Setting Timing:** Figure 11-44 shows the timing for setting of the TCFV flag in TSR by overflow occurrence, and TCIV interrupt request signal timing.

Figure 11-45 shows the timing for setting of the TCFU flag in TSR by underflow occurrence, and TCIU interrupt request signal timing.



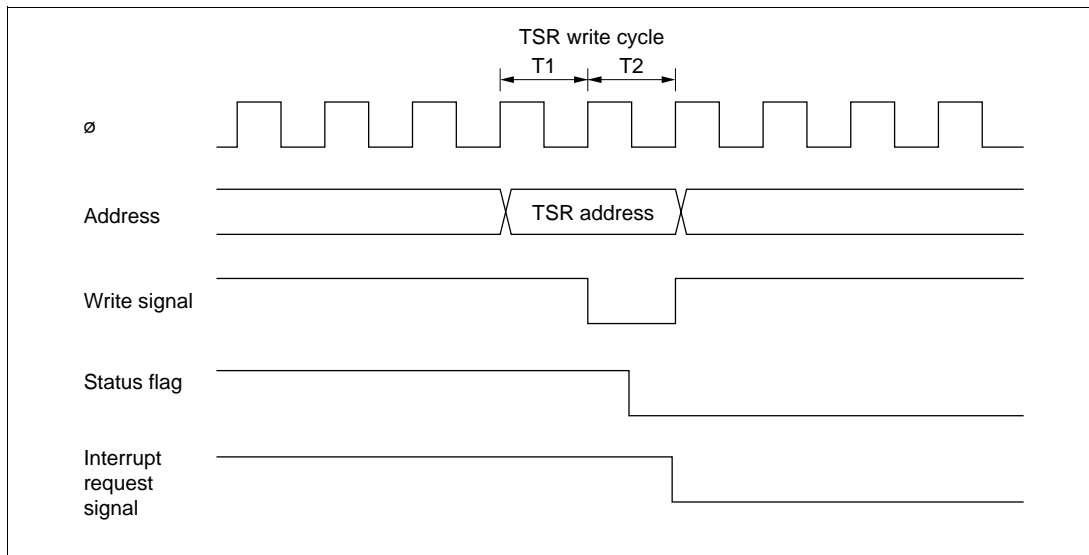
**Figure 11-44 TCIV Interrupt Setting Timing**



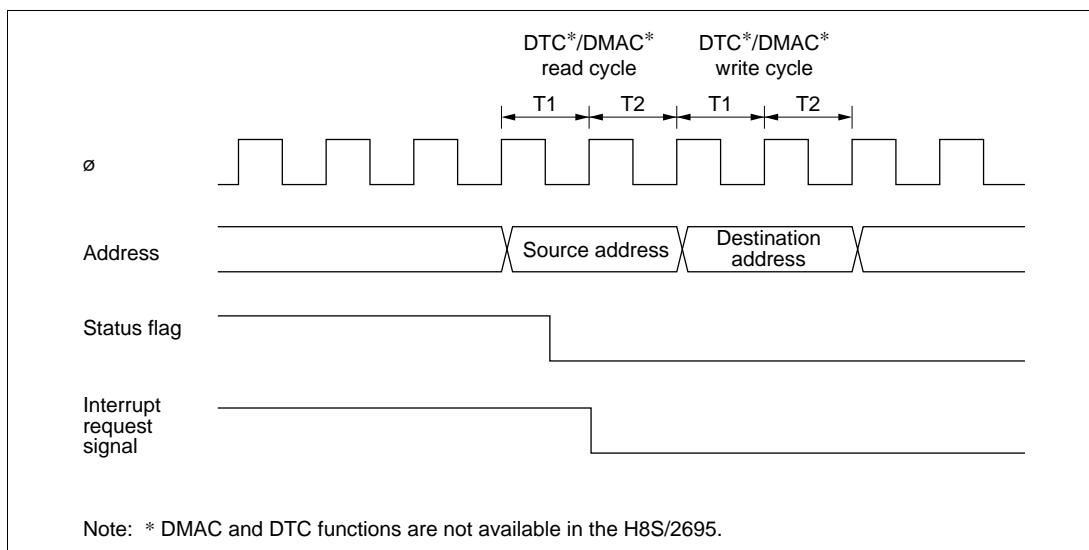
**Figure 11-45 TCIU Interrupt Setting Timing**

**Status Flag Clearing Timing:** After a status flag is read as 1 by the CPU, it is cleared by writing 0 to it. When the DTC\* or DMAC\* is activated, the flag is cleared automatically. Figure 11-46 shows the timing for status flag clearing by the CPU, and figure 11-47 shows the timing for status flag clearing by the DTC\* or DMAC\*.

Note: \* DMAC and DTC functions are not available in the H8S/2695.



**Figure 11-46 Timing for Status Flag Clearing by CPU**



Note: \* DMAC and DTC functions are not available in the H8S/2695.

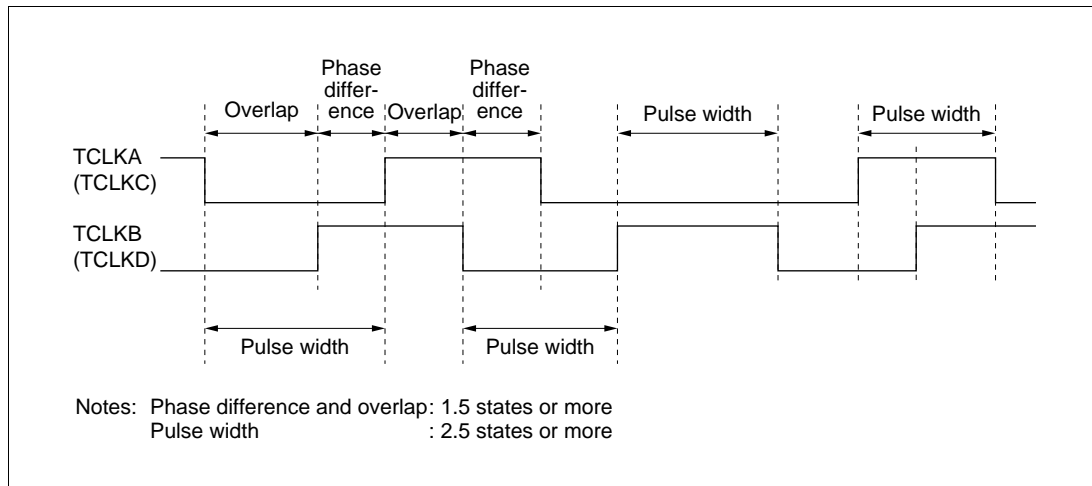
**Figure 11-47 Timing for Status Flag Clearing by DTC\* or DMAC\* Activation**

## 11.7 Usage Notes

Note that the kinds of operation and contention described below occur during TPU operation.

**Input Clock Restrictions:** The input clock pulse width must be at least 1.5 states in the case of single-edge detection, and at least 2.5 states in the case of both-edge detection. The TPU will not operate properly with a narrower pulse width.

In phase counting mode, the phase difference and overlap between the two input clocks must be at least 1.5 states, and the pulse width must be at least 2.5 states. Figure 11-48 shows the input clock conditions in phase counting mode.



**Figure 11-48 Phase Difference, Overlap, and Pulse Width in Phase Counting Mode**

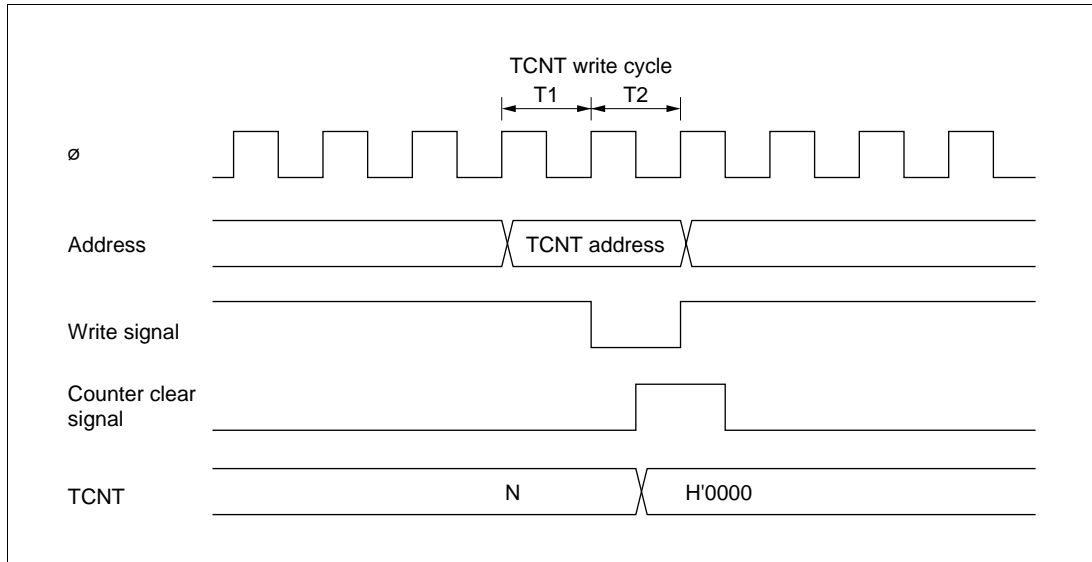
**Caution on Period Setting:** When counter clearing by compare match is set, TCNT is cleared in the final state in which it matches the TGR value (the point at which the count value matched by TCNT is updated). Consequently, the actual counter frequency is given by the following formula:

$$f = \frac{\phi}{(N + 1)}$$

Where    f : Counter frequency  
           $\phi$  : Operating frequency  
          N : TGR set value

**Contention between TCNT Write and Clear Operations:** If the counter clear signal is generated in the T2 state of a TCNT write cycle, TCNT clearing takes precedence and the TCNT write is not performed.

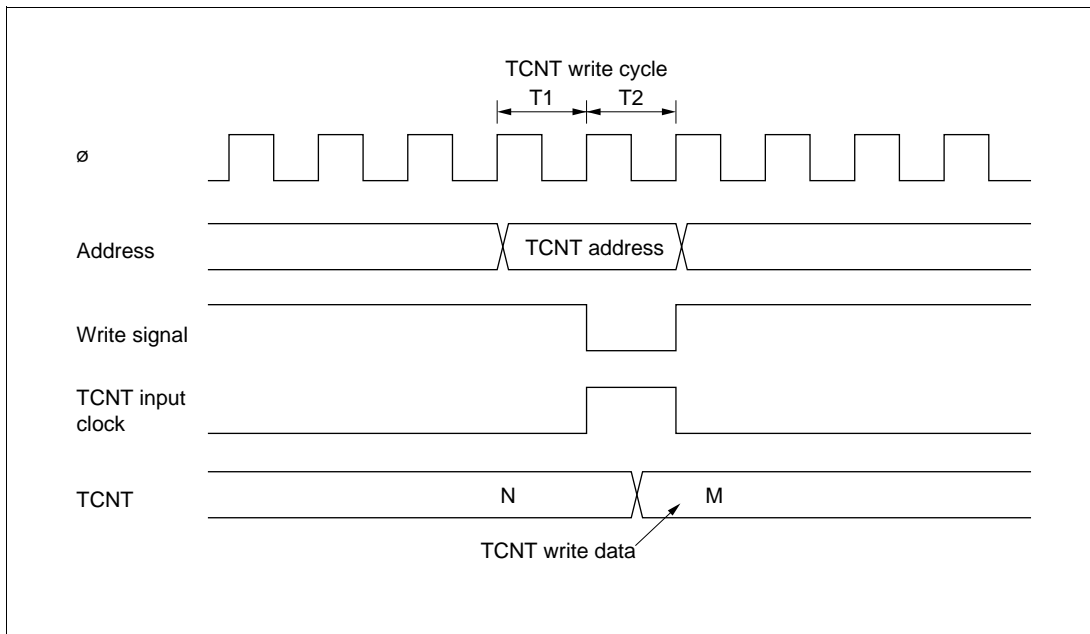
Figure 11-49 shows the timing in this case.



**Figure 11-49 Contention between TCNT Write and Clear Operations**

**Contention between TCNT Write and Increment Operations:** If incrementing occurs in the T2 state of a TCNT write cycle, the TCNT write takes precedence and TCNT is not incremented.

Figure 11-50 shows the timing in this case.

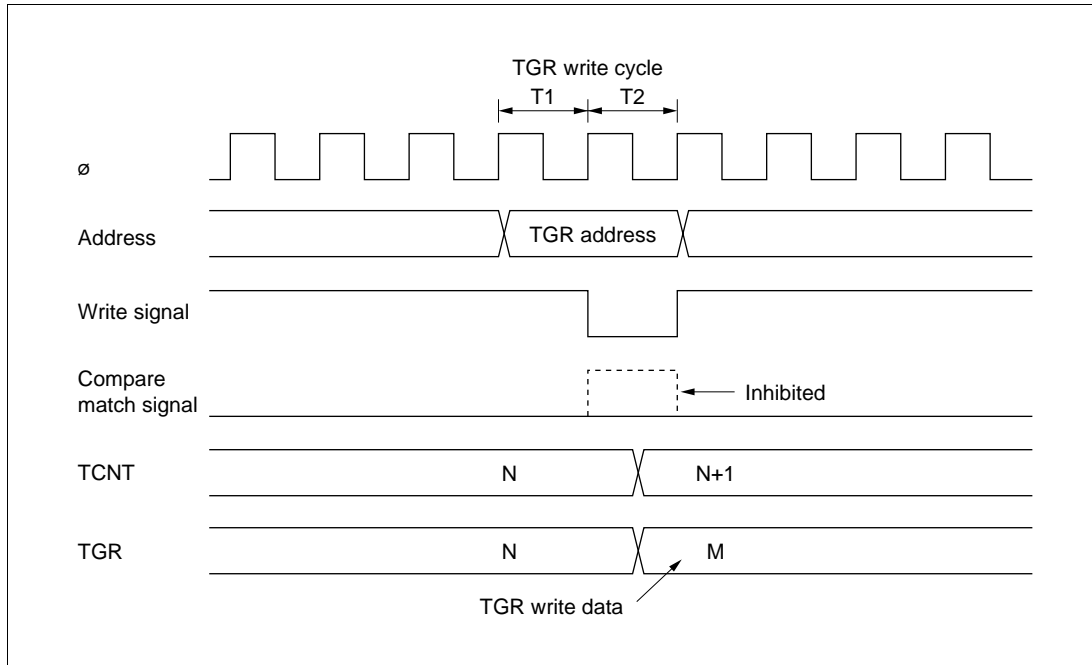


**Figure 11-50 Contention between TCNT Write and Increment Operations**



**Contention between TGR Write and Compare Match:** If a compare match occurs in the T2 state of a TGR write cycle, the TGR write takes precedence and the compare match signal is inhibited. A compare match does not occur even if the same value as before is written.

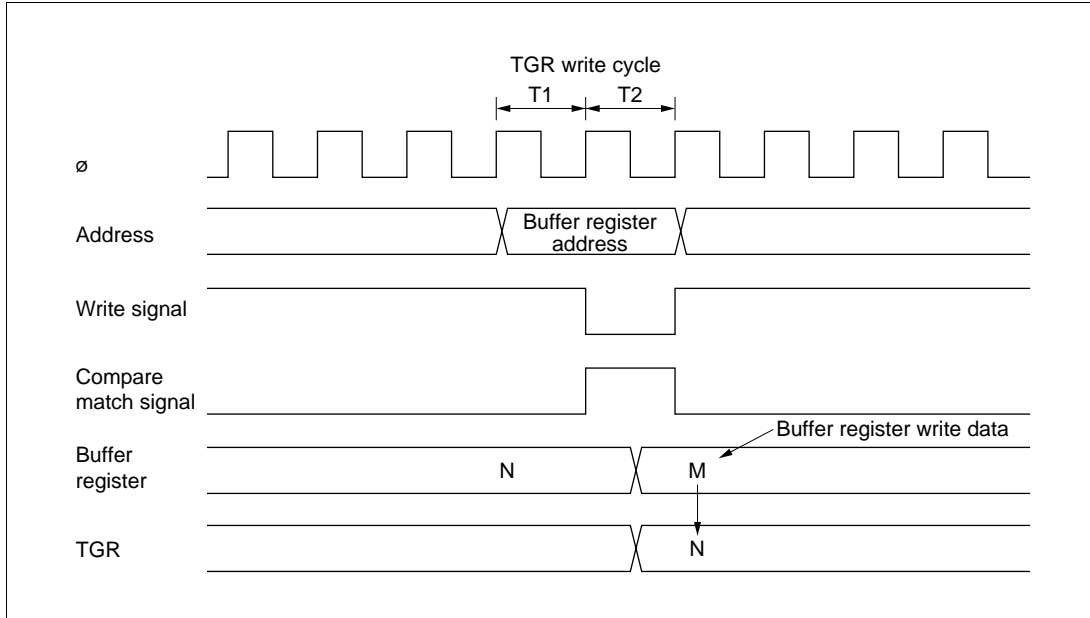
Figure 11-51 shows the timing in this case.



**Figure 11-51 Contention between TGR Write and Compare Match**

**Contention between Buffer Register Write and Compare Match:** If a compare match occurs in the T2 state of a TGR write cycle, the data transferred to TGR by the buffer operation will be the data prior to the write.

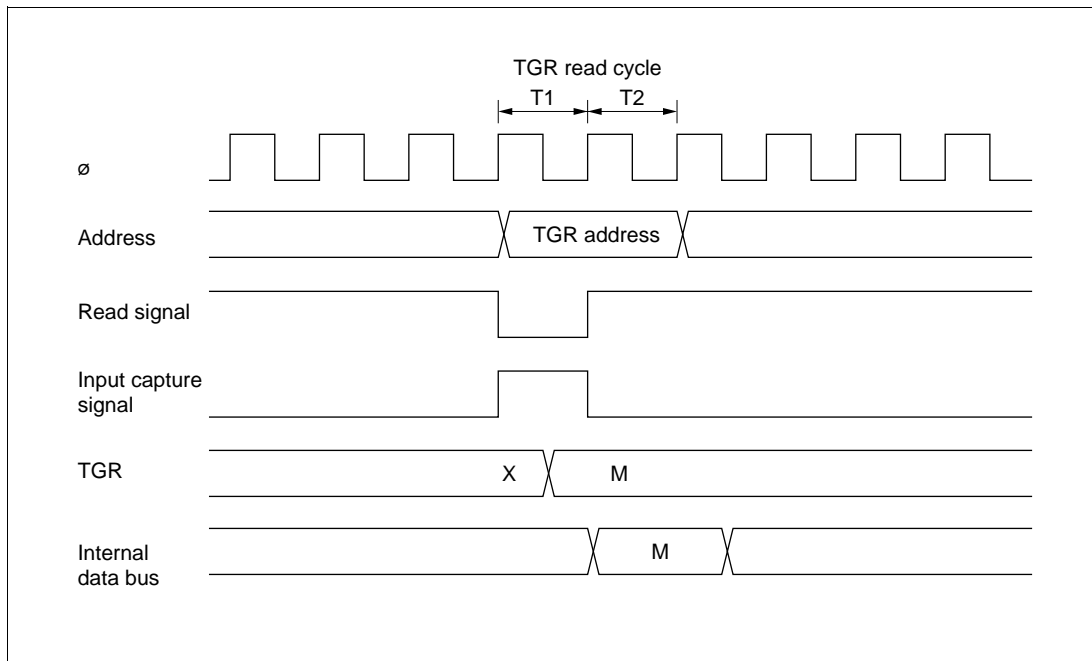
Figure 11-52 shows the timing in this case.



**Figure 11-52 Contention between Buffer Register Write and Compare Match**

**Contention between TGR Read and Input Capture:** If the input capture signal is generated in the T1 state of a TGR read cycle, the data that is read will be the data after input capture transfer.

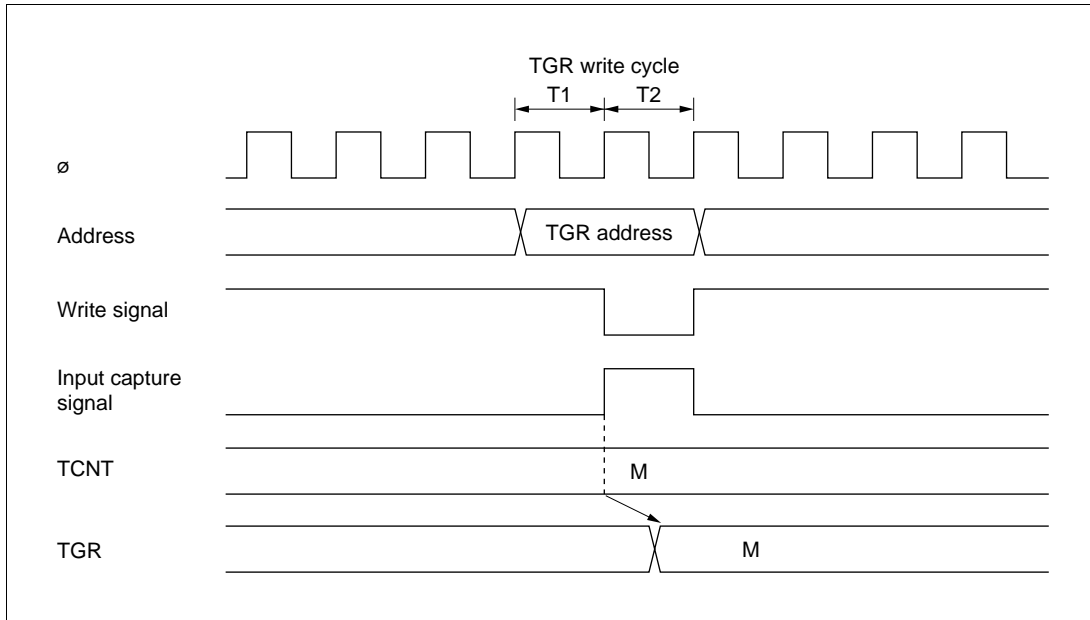
Figure 11-53 shows the timing in this case.



**Figure 11-53 Contention between TGR Read and Input Capture**

**Contention between TGR Write and Input Capture:** If the input capture signal is generated in the T2 state of a TGR write cycle, the input capture operation takes precedence and the write to TGR is not performed.

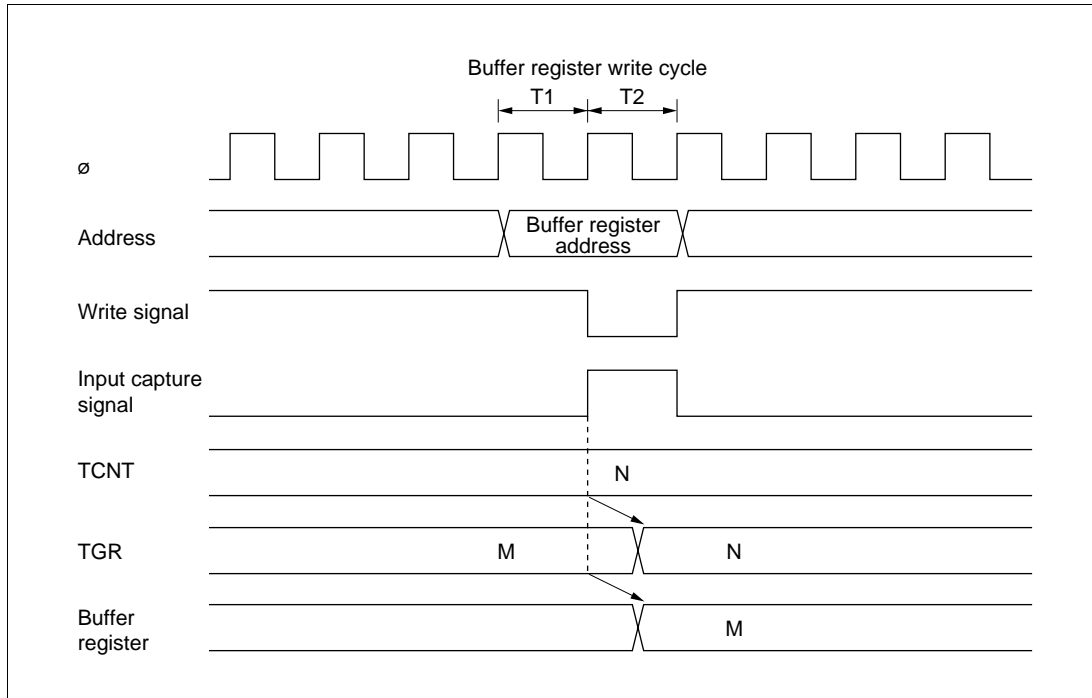
Figure 11-54 shows the timing in this case.



**Figure 11-54 Contention between TGR Write and Input Capture**

**Contention between Buffer Register Write and Input Capture:** If the input capture signal is generated in the T2 state of a buffer write cycle, the buffer operation takes precedence and the write to the buffer register is not performed.

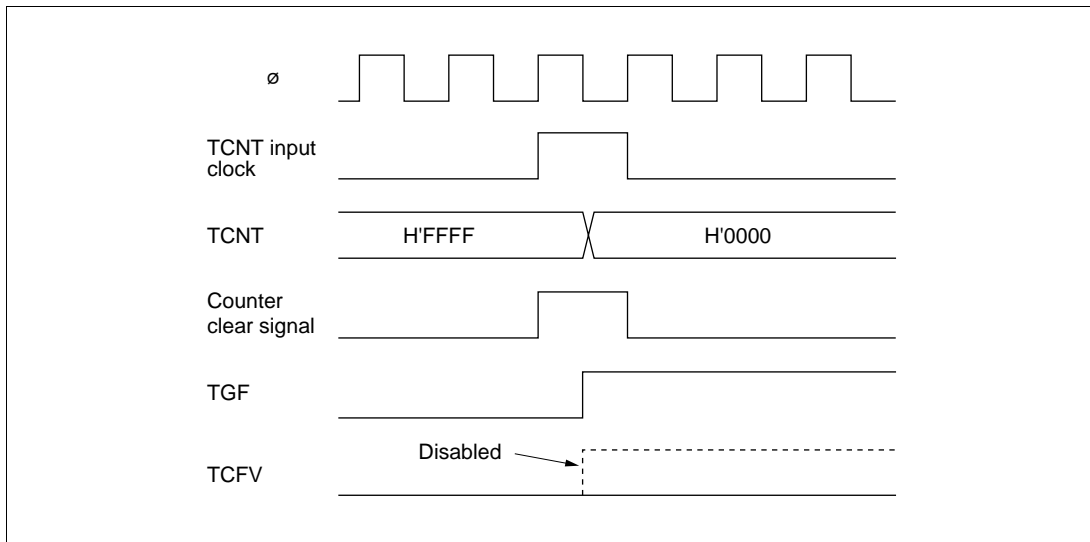
Figure 11-55 shows the timing in this case.



**Figure 11-55 Contention between Buffer Register Write and Input Capture**

**Contention between Overflow/Underflow and Counter Clearing:** If overflow/underflow and counter clearing occur simultaneously, the TCFV/TCFU flag in TSR is not set and TCNT clearing takes precedence.

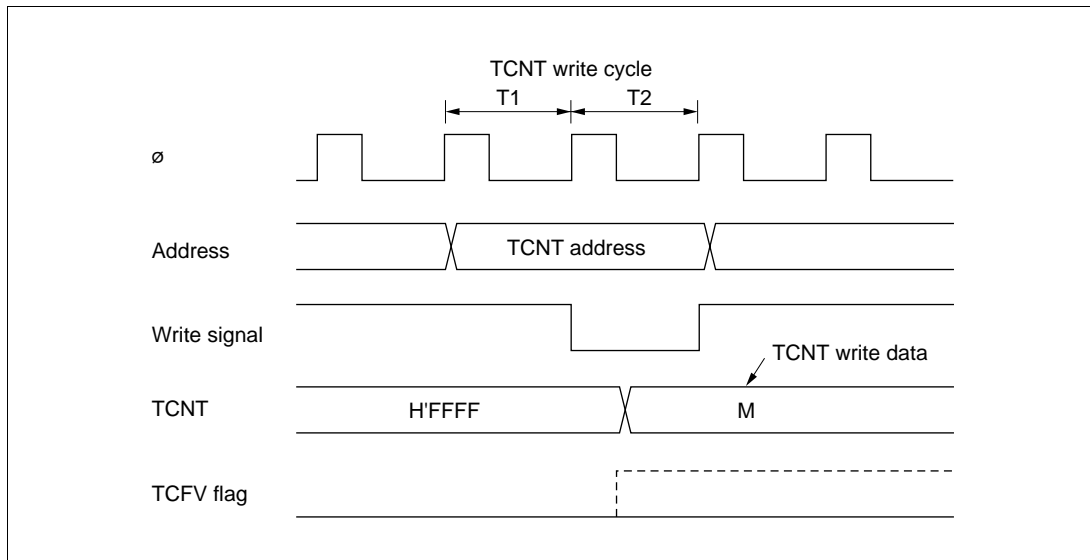
Figure 11-56 shows the operation timing when a TGR compare match is specified as the clearing source, and H'FFFF is set in TGR.



**Figure 11-56 Contention between Overflow and Counter Clearing**

**Contention between TCNT Write and Overflow/Underflow:** If there is an up-count or down-count in the T2 state of a TCNT write cycle, and overflow/underflow occurs, the TCNT write takes precedence and the TCFV/TCFU flag in TSR is not set.

Figure 11-57 shows the operation timing when there is contention between TCNT write and overflow.



**Figure 11-57 Contention between TCNT Write and Overflow**

**Multiplexing of I/O Pins:** In the H8S/2633 Series, the TCLKA input pin is multiplexed with the TIOCC0 I/O pin, the TCLKB input pin with the TIOCD0 I/O pin, the TCLKC input pin with the TIOCB1 I/O pin, and the TCLKD input pin with the TIOCB2 I/O pin. When an external clock is input, compare match output should not be performed from a multiplexed pin.

**Interrupts and Module Stop Mode:** If module stop mode is entered when an interrupt has been requested, it will not be possible to clear the CPU interrupt source or the DMAC\* or DTC\* activation source. Interrupts should therefore be disabled before entering module stop mode.

Note: \* This function is not available in the H8S/2695.





## Section 12 Programmable Pulse Generator (PPG)

(This function is not available in the H8S/2695)

### 12.1 Overview

The H8S/2633 Series has a built-in programmable pulse generator (PPG) that provides pulse outputs by using the 16-bit timer-pulse unit (TPU) as a time base. The PPG pulse outputs are divided into 4-bit groups (group 3 and group 2) that can operate both simultaneously and independently.

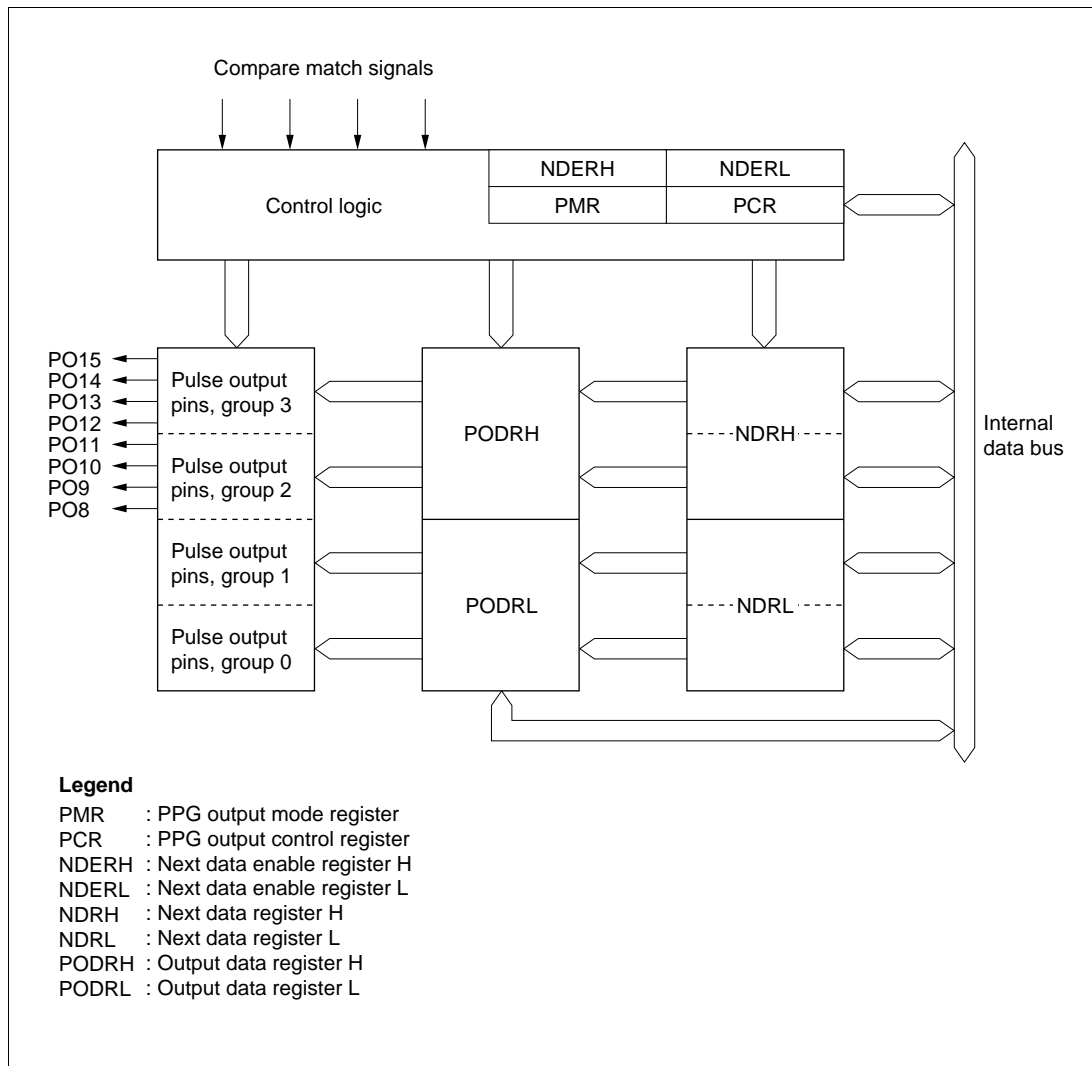
#### 12.1.1 Features

PPG features are listed below.

- 8-bit output data
  - Maximum 8-bit data can be output, and output can be enabled on a bit-by-bit basis
- Two output groups
  - Output trigger signals can be selected in 4-bit groups to provide up to two different 4-bit outputs
- Selectable output trigger signals
  - Output trigger signals can be selected for each group from the compare match signals of four TPU channels
- Non-overlap mode
  - A non-overlap margin can be provided between pulse outputs
- Can operate together with the data transfer controller (DTC) and DMA controller (DMAC)
  - The compare match signals selected as output trigger signals can activate the DTC or DMAC for sequential output of data without CPU intervention
- Settable inverted output
  - Inverted data can be output for each group
- Module stop mode can be set
  - As the initial setting, PPG operation is halted. Register access is enabled by exiting module stop mode

### 12.1.2 Block Diagram

Figure 12-1 shows a block diagram of the PPG.



**Figure 12-1 Block Diagram of PPG**

### 12.1.3 Pin Configuration

Table 12-1 summarizes the PPG pins.

**Table 12-1 PPG Pins**

<b>Name</b>	<b>Symbol</b>	<b>I/O</b>	<b>Function</b>
Pulse output 8	PO8	Output	Group 2 pulse output
Pulse output 9	PO9	Output	
Pulse output 10	PO10	Output	
Pulse output 11	PO11	Output	Group 3 pulse output
Pulse output 12	PO12	Output	
Pulse output 13	PO13	Output	
Pulse output 14	PO14	Output	
Pulse output 15	PO15	Output	

## 12.1.4 Registers

Table 12-2 summarizes the PPG registers.

**Table 12-2 PPG Registers**

Name	Abbreviation	R/W	Initial Value	Address*1
PPG output control register	PCR	R/W	H'FF	H'FE26
PPG output mode register	PMR	R/W	H'F0	H'FE27
Next data enable register H	NDERH	R/W	H'00	H'FE28
Next data enable register L*4	NDERL	R/W	H'00	H'FE29
Output data register H	PODRH	R/(W)*2	H'00	H'FE2A
Output data register L*4	PODRL	R/(W)*2	H'00	H'FE2B
Next data register H	NDRH	R/W	H'00	H'FE2C*3 H'FE2E
Next data register L*4	NDRL	R/W	H'00	H'FE2D*3 H'FE2F
Port 1 data direction register	P1DDR	W	H'00	H'FE30
Module stop control register A	MSTPCRA	R/W	H'3F	H'FDE8

Notes: \*1 Lower 16 bits of the address.

\*2 A bit that has been set for pulse output by NDER is read-only.

\*3 When the same output trigger is selected for pulse output groups 2 and 3 by the PCR setting, the NDRH address is H'FE2C. When the output triggers are different, the NDRH address is H'FE2E for group 2 and H'FE2C for group 3.

Similarly, when the same output trigger is selected for pulse output groups 0 and 1 by the PCR setting, the NDRL address is H'FE2D. When the output triggers are different, the NDRL address is H'FE2F for group 0 and H'FE2D for group 1.

\*4 The H8S/2633 Series has no pins corresponding to pulse output groups 0 and 1.

## 12.2 Register Descriptions

### 12.2.1 Next Data Enable Registers H and L (NDERH, NDERL)

#### NDERH

Bit	:	7	6	5	4	3	2	1	0
		NDER15	NDER14	NDER13	NDER12	NDER11	NDER10	NDER9	NDER8
Initial value :		0	0	0	0	0	0	0	0
R/W	:	R/W	R/W	R/W	R/W	R/W	R/W	R/W	R/W

#### NDERL

Bit	:	7	6	5	4	3	2	1	0
		NDER7	NDER6	NDER5	NDER4	NDER3	NDER2	NDER1	NDER0
Initial value :		0	0	0	0	0	0	0	0
R/W	:	R/W	R/W	R/W	R/W	R/W	R/W	R/W	R/W

NDERH and NDERL are 8-bit readable/writable registers that enable or disable pulse output on a bit-by-bit basis.

If a bit is enabled for pulse output by NDERH or NDERL, the NDR value is automatically transferred to the corresponding PODR bit when the TPU compare match event specified by PCR occurs, updating the output value. If pulse output is disabled, the bit value is not transferred from NDR to PODR and the output value does not change.

NDERH and NDERL are each initialized to H'00 by a reset and in hardware standby mode. They are not initialized in software standby mode.

**NDERH Bits 7 to 0—Next Data Enable 15 to 8 (NDER15 to NDER8):** These bits enable or disable pulse output on a bit-by-bit basis.

#### Bits 7 to 0

NDER15 to NDER8	Description
0	Pulse outputs PO15 to PO8 are disabled (NDR15 to NDR8 are not transferred to POD15 to POD8) (Initial value)
1	Pulse outputs PO15 to PO8 are enabled (NDR15 to NDR8 are transferred to POD15 to POD8)

**NDERL Bits 7 to 0—Next Data Enable 7 to 0 (NDER7 to NDER0):** These bits enable or disable pulse output on a bit-by-bit basis. However, the H8S/2633 Series has no output pins corresponding to NDRL.

**Bits 7 to 0**

NDER7 to NDER0	Description
0	Pulse outputs PO7 to PO0 are disabled (NDR7 to NDR0 are not transferred to POD7 to POD0) (Initial value)
1	Pulse outputs PO7 to PO0 are enabled (NDR7 to NDR0 are transferred to POD7 to POD0)

**12.2.2 Output Data Registers H and L (PODRH, PODRL)**

**PODRH**

Bit	:	7	6	5	4	3	2	1	0
		POD15	POD14	POD13	POD12	POD11	POD10	POD9	POD8
Initial value :		0	0	0	0	0	0	0	0
R/W	:	R/(W)*	R/(W)*	R/(W)*	R/(W)*	R/(W)*	R/(W)*	R/(W)*	R/(W)*

**PODRL**

Bit	:	7	6	5	4	3	2	1	0
		POD7	POD6	POD5	POD4	POD3	POD2	POD1	POD0
Initial value :		0	0	0	0	0	0	0	0
R/W	:	R/(W)*	R/(W)*	R/(W)*	R/(W)*	R/(W)*	R/(W)*	R/(W)*	R/(W)*

Note: \* A bit that has been set for pulse output by NDER is read-only.

PODRH and PODRL are 8-bit readable/writable registers that store output data for use in pulse output. However, the H8S/2633 Series has no pins corresponding to PODRL.

### 12.2.3 Next Data Registers H and L (NDRH, NDRL)

NDRH and NDRL are 8-bit readable/writable registers that store the next data for pulse output. During pulse output, the contents of NDRH and NDRL are transferred to the corresponding bits in PODRH and PODRL when the TPU compare match event specified by PCR occurs. The NDRH and NDRL addresses differ depending on whether pulse output groups have the same output trigger or different output triggers. For details see section 12.2.4, Notes on NDR Access.

NDRH and NDRL are each initialized to H'00 by a reset and in hardware standby mode. They are not initialized in software standby mode.

### 12.2.4 Notes on NDR Access

The NDRH and NDRL addresses differ depending on whether pulse output groups have the same output trigger or different output triggers.

**Same Trigger for Pulse Output Groups:** If pulse output groups 2 and 3 are triggered by the same compare match event, the NDRH address is H'FE2C. The upper 4 bits belong to group 3 and the lower 4 bits to group 2. Address H'FE2E consists entirely of reserved bits that cannot be modified and are always read as 1.

#### Address H'FE2C

Bit	:	7	6	5	4	3	2	1	0
		NDR15	NDR14	NDR13	NDR12	NDR11	NDR10	NDR9	NDR8
Initial value	:	0	0	0	0	0	0	0	0
R/W	:	R/W	R/W	R/W	R/W	R/W	R/W	R/W	R/W

#### Address H'FE2E

Bit	:	7	6	5	4	3	2	1	0
		—	—	—	—	—	—	—	—
Initial value	:	1	1	1	1	1	1	1	1
R/W	:	—	—	—	—	—	—	—	—

If pulse output groups 0 and 1 are triggered by the same compare match event, the NDRL address is H'FE2D. The upper 4 bits belong to group 1 and the lower 4 bits to group 0. Address H'FE2F consists entirely of reserved bits that cannot be modified and are always read as 1. However, the H8S/2633 Series has no output pins corresponding to pulse output groups 0 and 1.

#### Address H'FE2D

Bit	:	7	6	5	4	3	2	1	0
		NDR7	NDR6	NDR5	NDR4	NDR3	NDR2	NDR1	NDR0
Initial value :		0	0	0	0	0	0	0	0
R/W	:	R/W	R/W	R/W	R/W	R/W	R/W	R/W	R/W

#### Address H'FE2F

Bit	:	7	6	5	4	3	2	1	0
		—	—	—	—	—	—	—	—
Initial value :		1	1	1	1	1	1	1	1
R/W	:	—	—	—	—	—	—	—	—

**Different Triggers for Pulse Output Groups:** If pulse output groups 2 and 3 are triggered by different compare match events, the address of the upper 4 bits in NDRH (group 3) is H'FE2C and the address of the lower 4 bits (group 2) is H'FE2E. Bits 3 to 0 of address H'FE2C and bits 7 to 4 of address H'FE2E are reserved bits that cannot be modified and are always read as 1.

#### Address H'FE2C

Bit	:	7	6	5	4	3	2	1	0
		NDR15	NDR14	NDR13	NDR12	—	—	—	—
Initial value :		0	0	0	0	1	1	1	1
R/W	:	R/W	R/W	R/W	R/W	—	—	—	—

#### Address H'FE2E

Bit	:	7	6	5	4	3	2	1	0
		—	—	—	—	NDR11	NDR10	NDR9	NDR8
Initial value :		1	1	1	1	0	0	0	0
R/W	:	—	—	—	—	R/W	R/W	R/W	R/W

If pulse output groups 0 and 1 are triggered by different compare match event, the address of the upper 4 bits in NDRL (group 1) is H'FE2D and the address of the lower 4 bits (group 0) is H'FE2F. Bits 3 to 0 of address H'FE2D and bits 7 to 4 of address H'FE2F are reserved bits that cannot be modified and are always read as 1. However, the H8S/2633 Series has no output pins corresponding to pulse output groups 0 and 1.



### Address H'FE2D

Bit	:	7	6	5	4	3	2	1	0
		NDR7	NDR6	NDR5	NDR4	—	—	—	—
Initial value :		0	0	0	0	1	1	1	1
R/W	:	R/W	R/W	R/W	R/W	—	—	—	—

### Address H'FE2F

Bit	:	7	6	5	4	3	2	1	0
		—	—	—	—	NDR3	NDR2	NDR1	NDR0
Initial value :		1	1	1	1	0	0	0	0
R/W	:	—	—	—	—	R/W	R/W	R/W	R/W

### 12.2.5 PPG Output Control Register (PCR)

Bit	:	7	6	5	4	3	2	1	0
		G3CMS1	G3CMS0	G2CMS1	G2CMS0	G1CMS1	G1CMS0	G0CMS1	G0CMS0
Initial value :		1	1	1	1	1	1	1	1
R/W	:	R/W	R/W	R/W	R/W	R/W	R/W	R/W	R/W

PCR is an 8-bit readable/writable register that selects output trigger signals for PPG outputs on a group-by-group basis.

PCR is initialized to H'FF by a reset and in hardware standby mode. It is not initialized in software standby mode.

**Bits 7 and 6—Group 3 Compare Match Select 1 and 0 (G3CMS1, G3CMS0):** These bits select the compare match that triggers pulse output group 3 (pins PO15 to PO12).

Bit 7	Bit 6	Description
<b>G3CMS1</b>	<b>G3CMS0</b>	<b>Output Trigger for Pulse Output Group 3</b>
0	0	Compare match in TPU channel 0
	1	Compare match in TPU channel 1
1	0	Compare match in TPU channel 2
	1	Compare match in TPU channel 3 (Initial value)

**Bits 5 and 4—Group 2 Compare Match Select 1 and 0 (G2CMS1, G2CMS0):** These bits select the compare match that triggers pulse output group 2 (pins PO11 to PO8).

Bit 5	Bit 4	Description
G2CMS1	G2CMS0	Output Trigger for Pulse Output Group 2
0	0	Compare match in TPU channel 0
	1	Compare match in TPU channel 1
1	0	Compare match in TPU channel 2
	1	Compare match in TPU channel 3 (Initial value)

**Bits 3 and 2—Group 1 Compare Match Select 1 and 0 (G1CMS1, G1CMS0):** These bits select the compare match that triggers pulse output group 1 (pins PO7 to PO4). However, the H8S/2633 Series has no output pins corresponding to pulse output group 1.

Bit 3	Bit 2	Description
G1CMS1	G1CMS0	Output Trigger for Pulse Output Group 1
0	0	Compare match in TPU channel 0
	1	Compare match in TPU channel 1
1	0	Compare match in TPU channel 2
	1	Compare match in TPU channel 3 (Initial value)

**Bits 1 and 0—Group 0 Compare Match Select 1 and 0 (G0CMS1, G0CMS0):** These bits select the compare match that triggers pulse output group 0 (pins PO3 to PO0). However, the H8S/2633 Series has no output pins corresponding to pulse output group 0.

Bit 1	Bit 0	Description
G0CMS1	G0CMS0	Output Trigger for Pulse Output Group 0
0	0	Compare match in TPU channel 0
	1	Compare match in TPU channel 1
1	0	Compare match in TPU channel 2
	1	Compare match in TPU channel 3 (Initial value)

### 12.2.6 PPG Output Mode Register (PMR)

Bit	:	7	6	5	4	3	2	1	0
		G3INV	G2INV	G1INV	G0INV	G3NOV	G2NOV	G1NOV	G0NOV
Initial value :		1	1	1	1	0	0	0	0
R/W	:	R/W	R/W	R/W	R/W	R/W	R/W	R/W	R/W

PMR is an 8-bit readable/writable register that selects pulse output inversion and non-overlapping operation for each group.

The output trigger period of a non-overlapping operation PPG output waveform is set in TGRB and the non-overlap margin is set in TGRA. The output values change at compare match A and B.

For details, see section 12.3.4, Non-Overlapping Pulse Output.

PMR is initialized to H'F0 by a reset and in hardware standby mode. It is not initialized in software standby mode.

**Bit 7—Group 3 Inversion (G3INV):** Selects direct output or inverted output for pulse output group 3 (pins PO15 to PO12).

#### Bit 7

G3INV	Description
0	Inverted output for pulse output group 3 (low-level output at pin for a 1 in PODRH)
1	Direct output for pulse output group 3 (high-level output at pin for a 1 in PODRH) (Initial value)

**Bit 6—Group 2 Inversion (G2INV):** Selects direct output or inverted output for pulse output group 2 (pins PO11 to PO8).

#### Bit 6

G2INV	Description
0	Inverted output for pulse output group 2 (low-level output at pin for a 1 in PODRH)
1	Direct output for pulse output group 2 (high-level output at pin for a 1 in PODRH) (Initial value)

**Bit 5—Group 1 Inversion (G1INV):** Selects direct output or inverted output for pulse output group 1 (pins PO7 to PO4). However, the H8S/2633 Series has no pins corresponding to pulse output group 1.

**Bit 5**

<b>G1INV</b>	<b>Description</b>
0	Inverted output for pulse output group 1 (low-level output at pin for a 1 in PODRL)
1	Direct output for pulse output group 1 (high-level output at pin for a 1 in PODRL) (Initial value)

**Bit 4—Group 0 Inversion (G0INV):** Selects direct output or inverted output for pulse output group 0 (pins PO3 to PO0). However, the H8S/2633 Series has no pins corresponding to pulse output group 0.

**Bit 4**

<b>G0INV</b>	<b>Description</b>
0	Inverted output for pulse output group 0 (low-level output at pin for a 1 in PODRL)
1	Direct output for pulse output group 0 (high-level output at pin for a 1 in PODRL) (Initial value)

**Bit 3—Group 3 Non-Overlap (G3NOV):** Selects normal or non-overlapping operation for pulse output group 3 (pins PO15 to PO12).

**Bit 3**

<b>G3NOV</b>	<b>Description</b>
0	Normal operation in pulse output group 3 (output values updated at compare match A in the selected TPU channel) (Initial value)
1	Non-overlapping operation in pulse output group 3 (independent 1 and 0 output at compare match A or B in the selected TPU channel)

**Bit 2—Group 2 Non-Overlap (G2NOV):** Selects normal or non-overlapping operation for pulse output group 2 (pins PO11 to PO8).

**Bit 2**

<b>G2NOV</b>	<b>Description</b>
0	Normal operation in pulse output group 2 (output values updated at compare match A in the selected TPU channel) (Initial value)
1	Non-overlapping operation in pulse output group 2 (independent 1 and 0 output at compare match A or B in the selected TPU channel)

**Bit 1—Group 1 Non-Overlap (G1NOV):** Selects normal or non-overlapping operation for pulse output group 1 (pins PO7 to PO4). However, the H8S/2633 Series has no pins corresponding to pulse output group 1.

**Bit 1**

<b>G1NOV</b>	<b>Description</b>
0	Normal operation in pulse output group 1 (output values updated at compare match A in the selected TPU channel) (Initial value)
1	Non-overlapping operation in pulse output group 1 (independent 1 and 0 output at compare match A or B in the selected TPU channel)

**Bit 0—Group 0 Non-Overlap (G0NOV):** Selects normal or non-overlapping operation for pulse output group 0 (pins PO3 to PO0). However, the H8S/2633 Series has no pins corresponding to pulse output group 0.

**Bit 0**

<b>G0NOV</b>	<b>Description</b>
0	Normal operation in pulse output group 0 (output values updated at compare match A in the selected TPU channel) (Initial value)
1	Non-overlapping operation in pulse output group 0 (independent 1 and 0 output at compare match A or B in the selected TPU channel)

### 12.2.7 Port 1 Data Direction Register (P1DDR)

Bit	:	7	6	5	4	3	2	1	0
		P17DDR	P16DDR	P15DDR	P14DDR	P13DDR	P12DDR	P11DDR	P10DDR
Initial value :		0	0	0	0	0	0	0	0
R/W	:	W	W	W	W	W	W	W	W

P1DDR is an 8-bit write-only register, the individual bits of which specify input or output for the pins of port 1.

Port 1 is multiplexed with pins PO15 to PO8. Bits corresponding to pins used for PPG output must be set to 1. For further information about P1DDR, see sections 10A.2 and 10B.2, Port 1.

### 12.2.8 Module Stop Control Register A (MSTPCRA)

Bit	:	7	6	5	4	3	2	1	0
		MSTPA7	MSTPA6	MSTPA5	MSTPA4	MSTPA3	MSTPA2	MSTPA1	MSTPA0
Initial value :		0	0	1	1	1	1	1	1
R/W	:	R/W	R/W	R/W	R/W	R/W	R/W	R/W	R/W

MSTPCRA is an 8-bit readable/writable register that performs module stop mode control.

When the MSTPA3 bit in MSTPCRA is set to 1, PPG operation stops at the end of the bus cycle and a transition is made to module stop mode. Registers cannot be read or written to in module stop mode. For details, see section 24.5, Module Stop Mode.

MSTPCRA is initialized to H'3F by a power-on reset and in hardware standby mode. It is not initialized by a manual reset and in software standby mode.

**Bit 3—Module Stop (MSTPA3):** Specifies the PPG module stop mode.

#### Bit 3

MSTPA3	Description
0	PPG module stop mode cleared
1	PPG module stop mode set (Initial value)

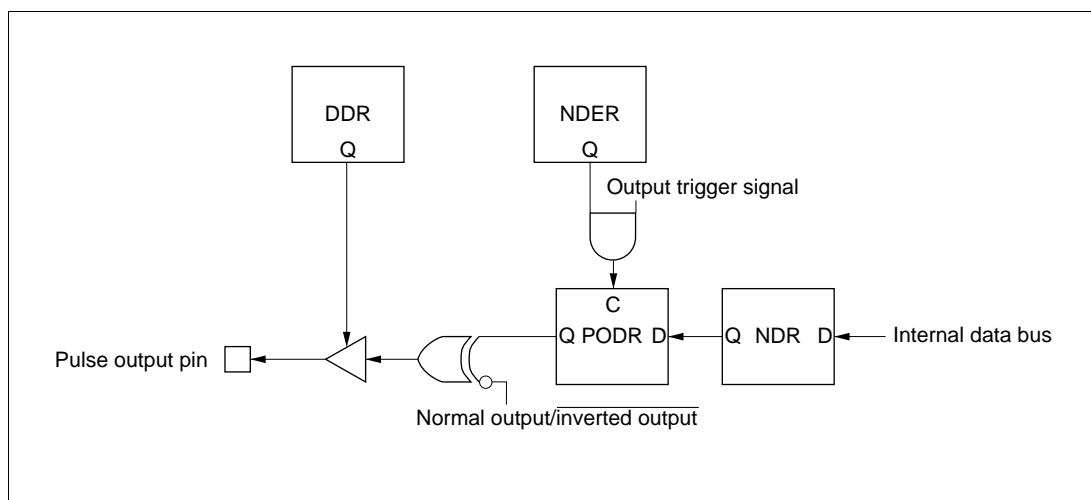
## 12.3 Operation

### 12.3.1 Overview

PPG pulse output is enabled when the corresponding bits in P1DDR and NDER are set to 1. In this state the corresponding PODR contents are output.

When the compare match event specified by PCR occurs, the corresponding NDR bit contents are transferred to PODR to update the output values.

Figure 12-2 illustrates the PPG output operation and table 12-3 summarizes the PPG operating conditions.



**Figure 12-2 PPG Output Operation**

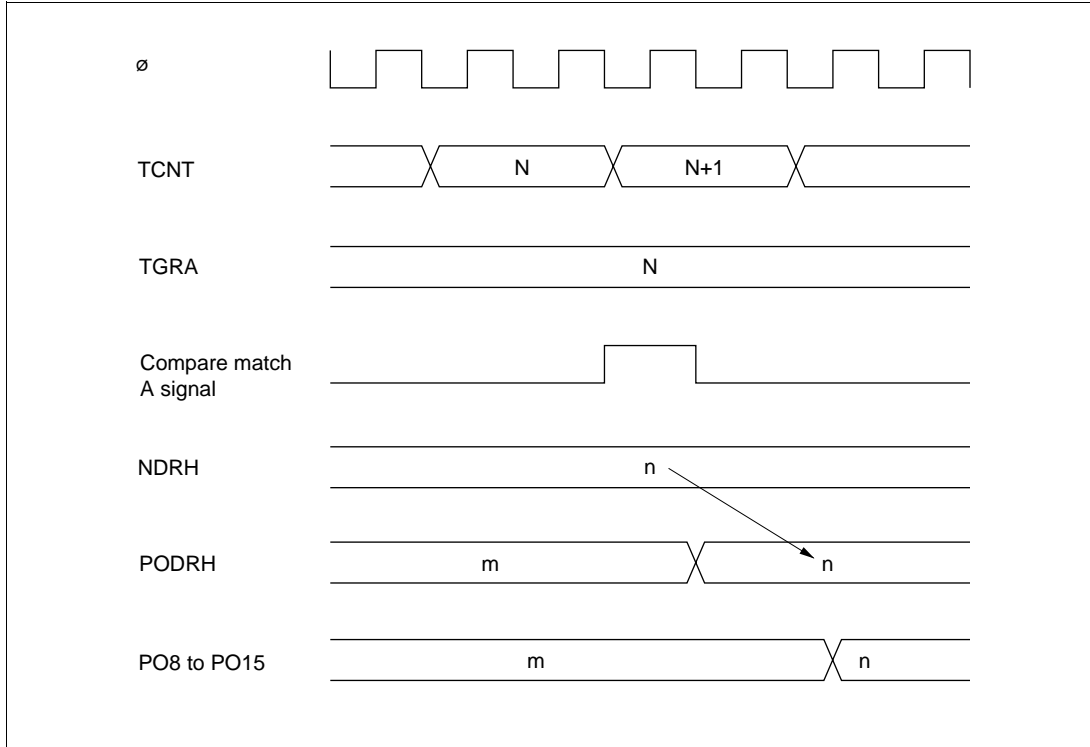
**Table 12-3 PPG Operating Conditions**

NDR	DDR	Pin Function
0	0	Generic input port
	1	Generic output port
1	0	Generic input port (but the PODR bit is a read-only bit, and when compare match occurs, the NDR bit value is transferred to the PODR bit)
	1	PPG pulse output

Sequential output of data of up to 16 bits is possible by writing new output data to NDR before the next compare match. For details of non-overlapping operation, see section 12.3.4, Non-Overlapping Pulse Output.

### 12.3.2 Output Timing

If pulse output is enabled, NDR contents are transferred to PODR and output when the specified compare match event occurs. Figure 12-3 shows the timing of these operations for the case of normal output in groups 2 and 3, triggered by compare match A.

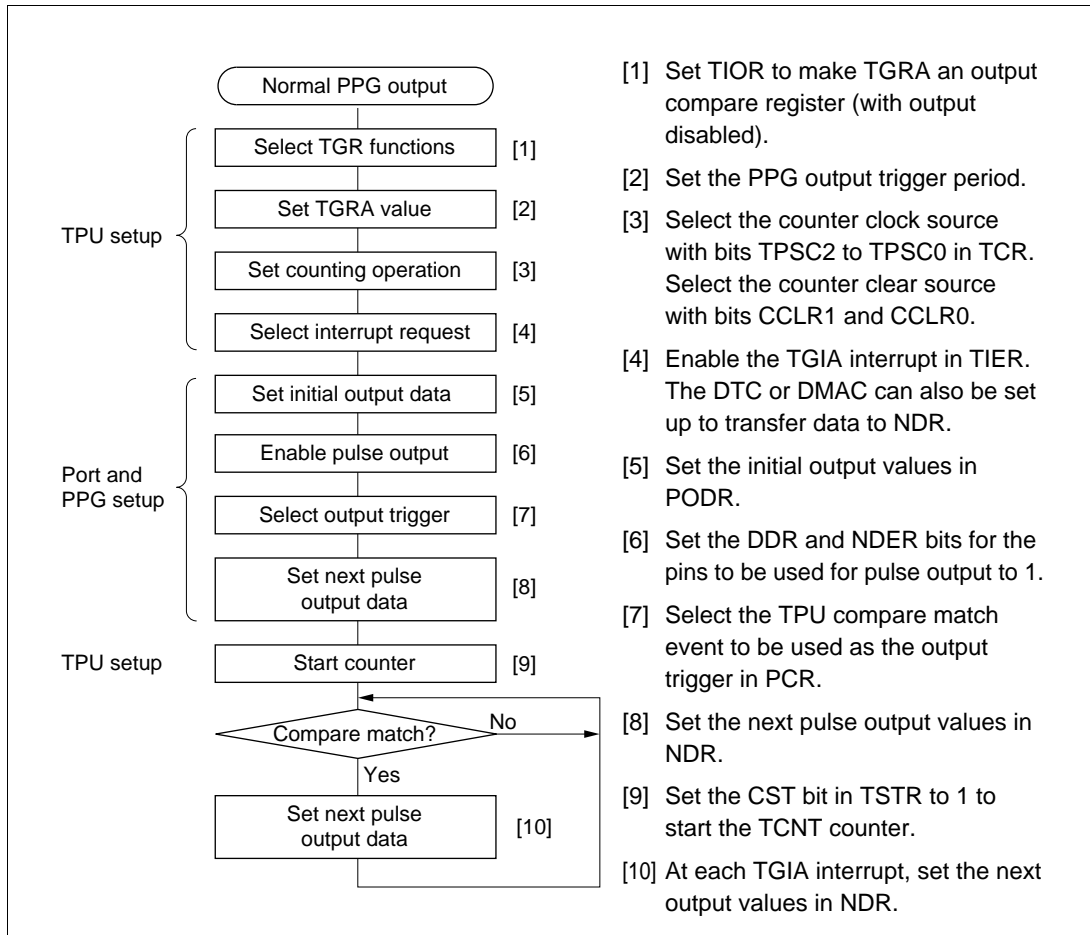


**Figure 12-3 Timing of Transfer and Output of NDR Contents (Example)**



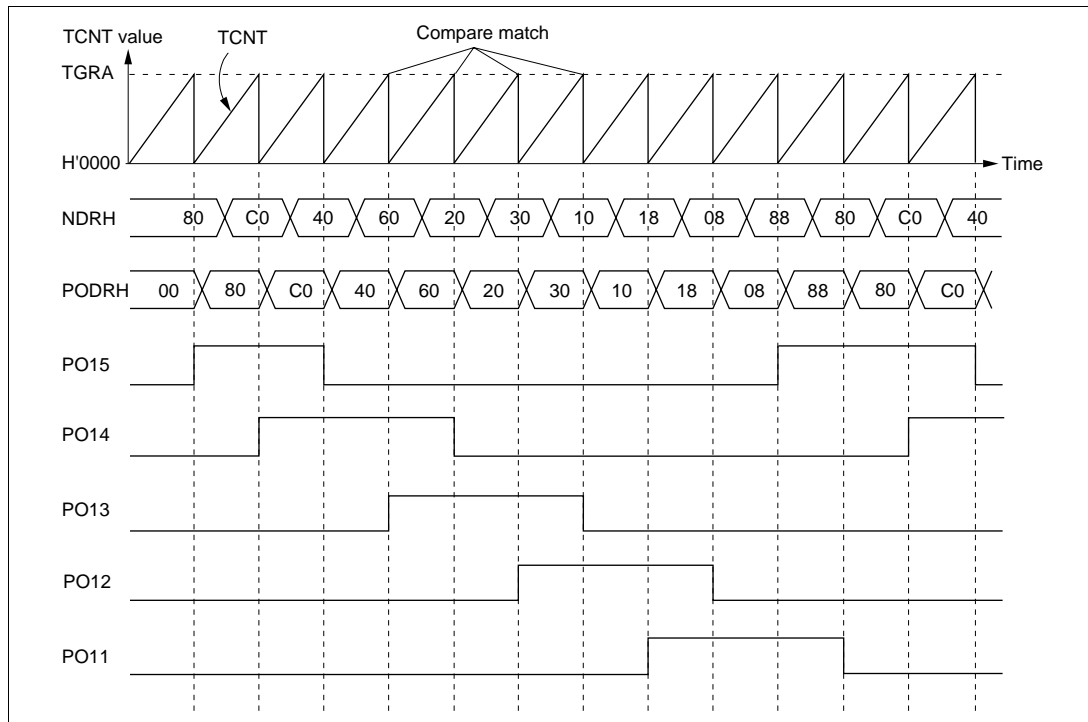
### 12.3.3 Normal Pulse Output

**Sample Setup Procedure for Normal Pulse Output:** Figure 12-4 shows a sample procedure for setting up normal pulse output.



**Figure 12-4 Setup Procedure for Normal Pulse Output (Example)**

**Example of Normal Pulse Output (Example of Five-Phase Pulse Output):** Figure 12-5 shows an example in which pulse output is used for cyclic five-phase pulse output.

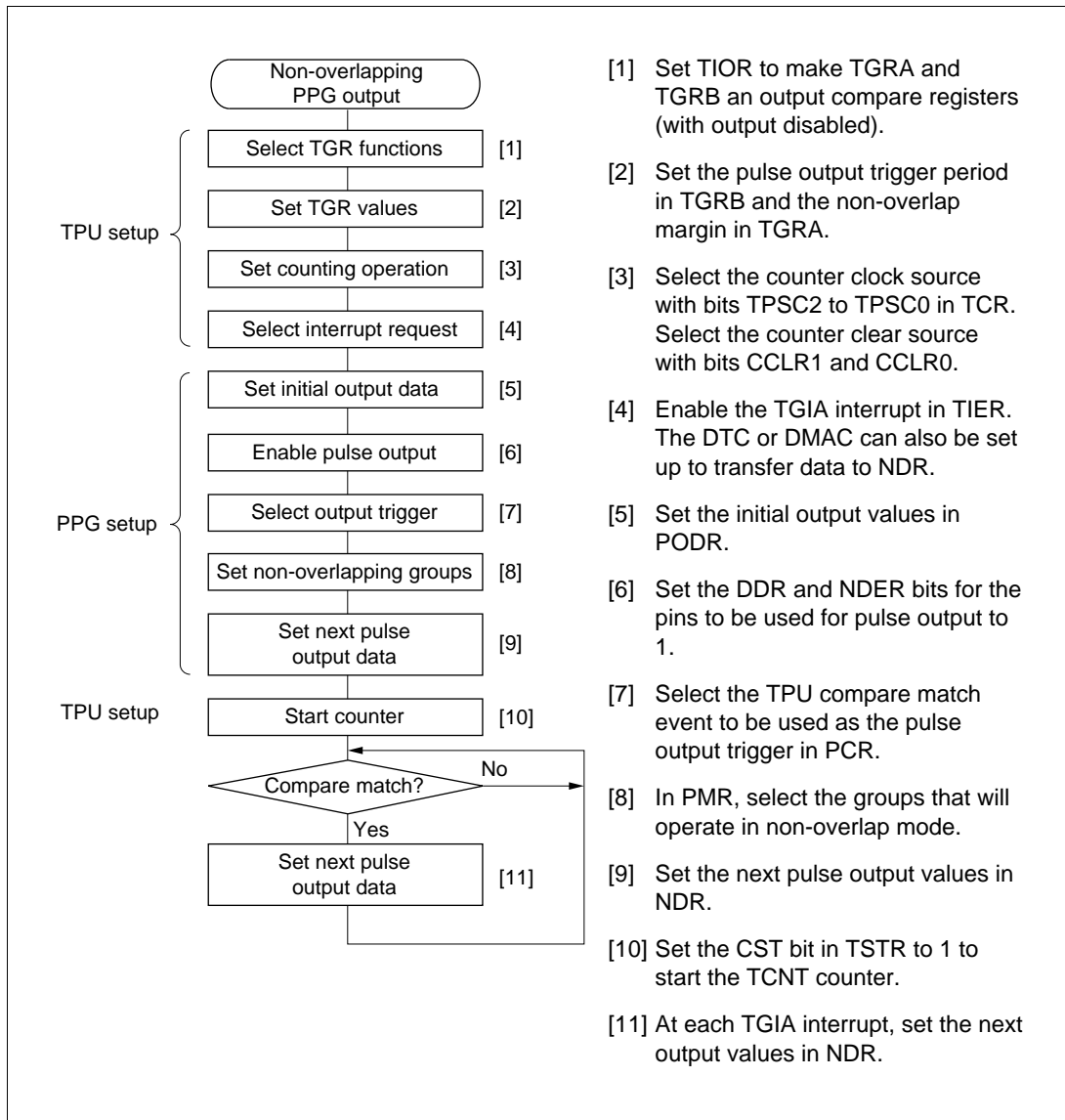


**Figure 12-5 Normal Pulse Output Example (Five-Phase Pulse Output)**

- [1] Set up the TPU channel to be used as the output trigger channel so that TGRA is an output compare register and the counter will be cleared by compare match A. Set the trigger period in TGRA and set the TGIEA bit in TIER to 1 to enable the compare match A (TGIA) interrupt.
- [2] Write H'F8 in P1DDR and NDRH, and set the G3CMS1, G3CMS0, G2CMS1, and G2CMS0 bits in PCR to select compare match in the TPU channel set up in the previous step to be the output trigger. Write output data H'80 in NDRH.
- [3] The timer counter in the TPU channel starts. When compare match A occurs, the NDRH contents are transferred to PODRH and output. The TGIA interrupt handling routine writes the next output data (H'C0) in NDRH.
- [4] Five-phase overlapping pulse output (one or two phases active at a time) can be obtained subsequently by writing H'40, H'60, H'20, H'30, H'10, H'18, H'08, H'88... at successive TGIA interrupts. If the DTC or DMAC is set for activation by this interrupt, pulse output can be obtained without imposing a load on the CPU.

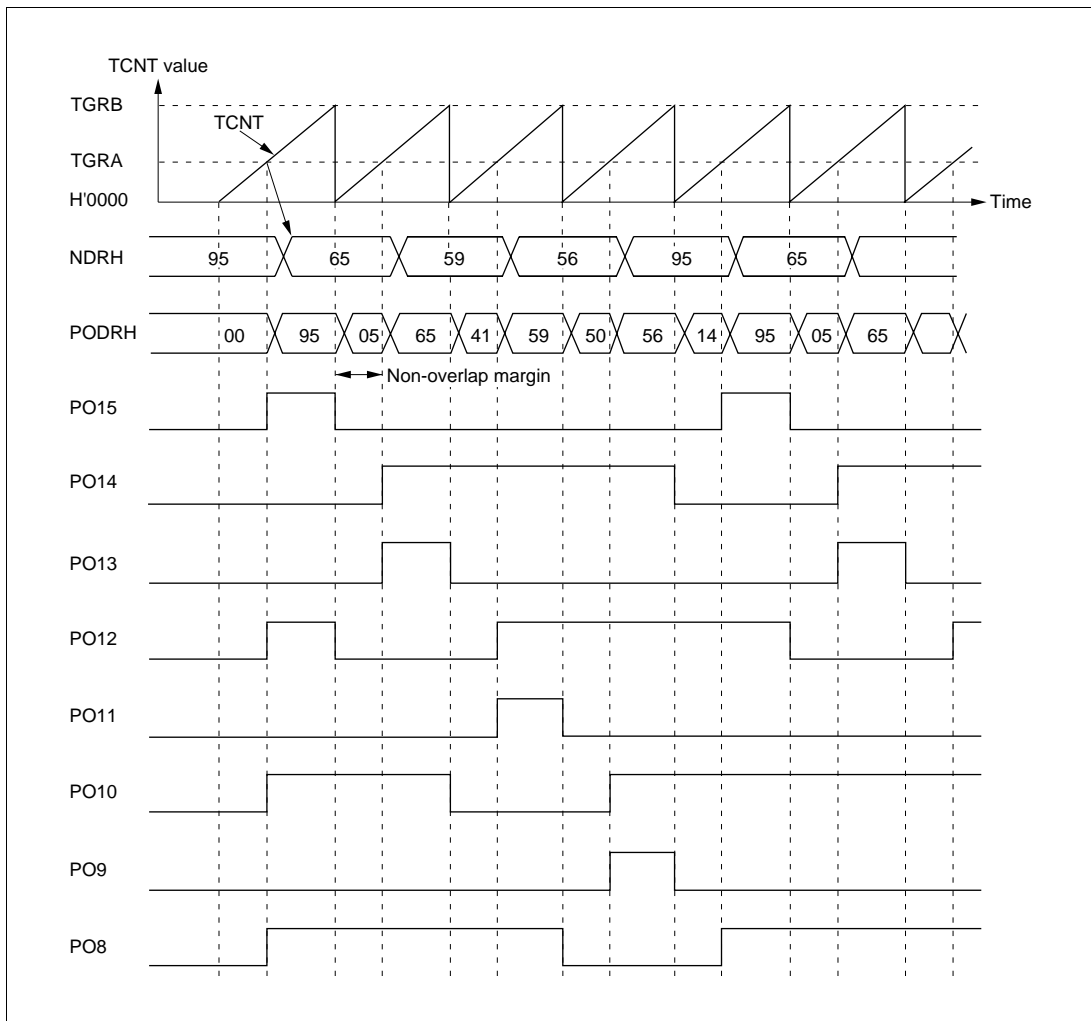
### 12.3.4 Non-Overlapping Pulse Output

**Sample Setup Procedure for Non-Overlapping Pulse Output:** Figure 12-6 shows a sample procedure for setting up non-overlapping pulse output.



**Figure 12-6 Setup Procedure for Non-Overlapping Pulse Output (Example)**

**Example of Non-Overlapping Pulse Output (Example of Four-Phase Complementary Non-Overlapping Output):** Figure 12-7 shows an example in which pulse output is used for four-phase complementary non-overlapping pulse output.



**Figure 12-7 Non-Overlapping Pulse Output Example (Four-Phase Complementary)**

- [1] Set up the TPU channel to be used as the output trigger channel so that TGRA and TGRB are output compare registers. Set the trigger period in TGRB and the non-overlap margin in TGRA, and set the counter to be cleared by compare match B. Set the TGIEA bit in TIER to 1 to enable the TGIA interrupt.
- [2] Write H'FF in P1DDR and NDERH, and set the G3CMS1, G3CMS0, G2CMS1, and G2CMS0 bits in PCR to select compare match in the TPU channel set up in the previous step to be the output trigger. Set the G3NOV and G2NOV bits in PMR to 1 to select non-overlapping output. Write output data H'95 in NDRH.
- [3] The timer counter in the TPU channel starts. When a compare match with TGRB occurs, outputs change from 1 to 0. When a compare match with TGRA occurs, outputs change from 0 to 1 (the change from 0 to 1 is delayed by the value set in TGRA). The TGIA interrupt handling routine writes the next output data (H'65) in NDRH.
- [4] Four-phase complementary non-overlapping pulse output can be obtained subsequently by writing H'59, H'56, H'95... at successive TGIA interrupts. If the DTC or DMAC is set for activation by this interrupt, pulse output can be obtained without imposing a load on the CPU.

### 12.3.5 Inverted Pulse Output

If the G3INV, G2INV, G1INV, and G0INV bits in PMR are cleared to 0, values that are the inverse of the PODR contents can be output.

Figure 12-8 shows the outputs when G3INV and G2INV are cleared to 0, in addition to the settings of figure 12-7.

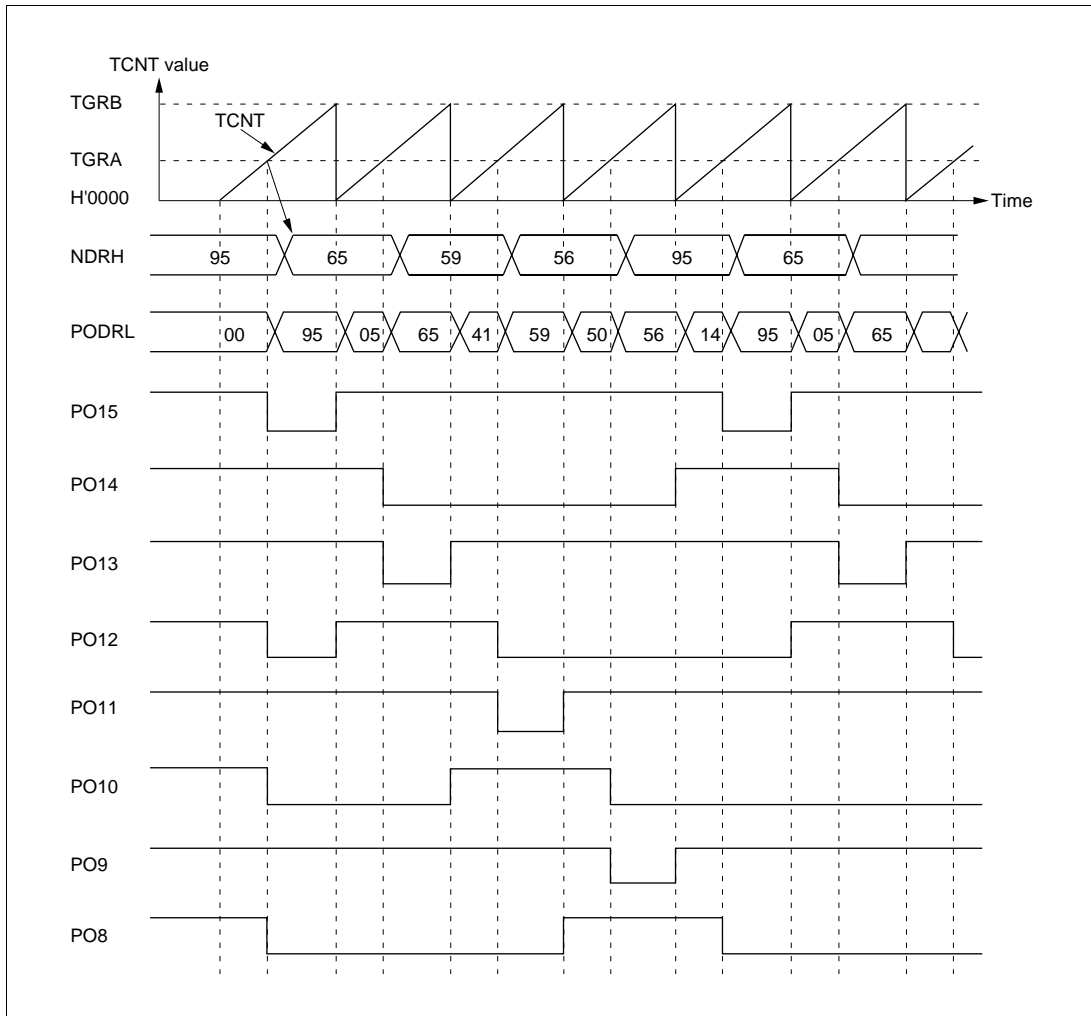


Figure 12-8 Inverted Pulse Output (Example)

### 12.3.6 Pulse Output Triggered by Input Capture

Pulse output can be triggered by TPU input capture as well as by compare match. If TGRA functions as an input capture register in the TPU channel selected by PCR, pulse output will be triggered by the input capture signal.

Figure 12-9 shows the timing of this output.

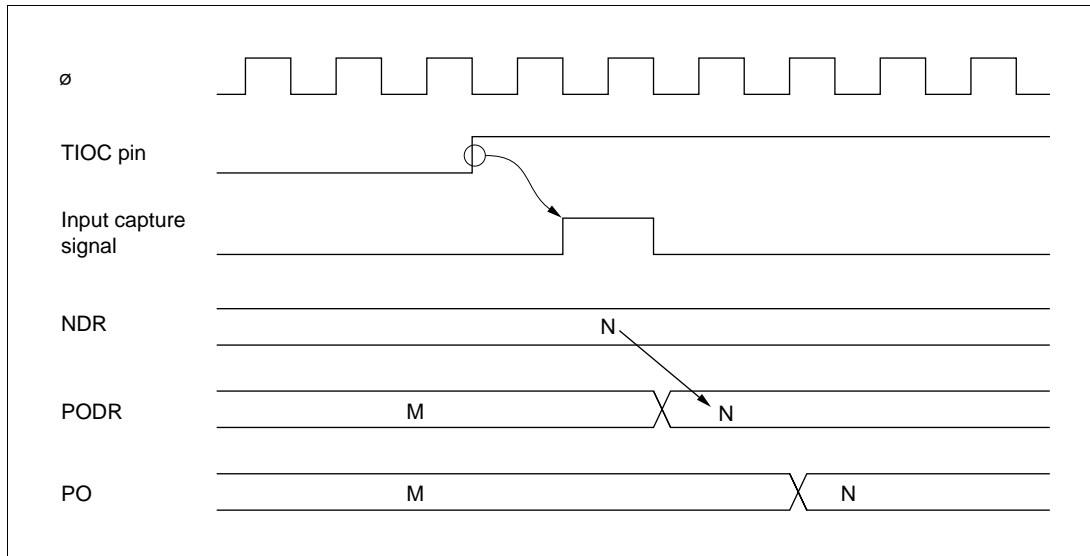


Figure 12-9 Pulse Output Triggered by Input Capture (Example)

## 12.4 Usage Notes

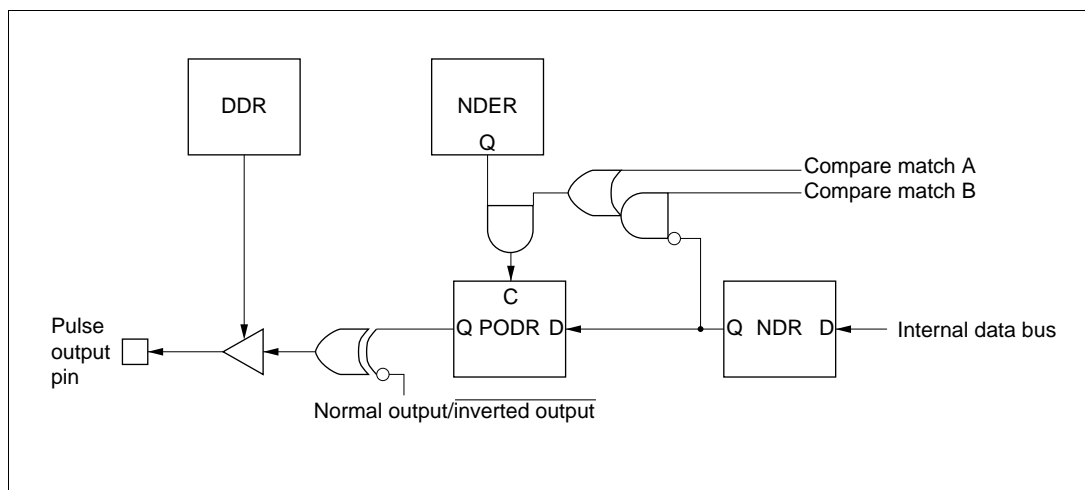
**Operation of Pulse Output Pins:** Pins PO8 to PO15 are also used for other peripheral functions such as the TPU. When output by another peripheral function is enabled, the corresponding pins cannot be used for pulse output. Note, however, that data transfer from NDR bits to PODR bits takes place, regardless of the usage of the pins.

Pin functions should be changed only under conditions in which the output trigger event will not occur.

**Note on Non-Overlapping Output:** During non-overlapping operation, the transfer of NDR bit values to PODR bits takes place as follows.

- NDR bits are always transferred to PODR bits at compare match A.
- At compare match B, NDR bits are transferred only if their value is 0. Bits are not transferred if their value is 1.

Figure 12-10 illustrates the non-overlapping pulse output operation.



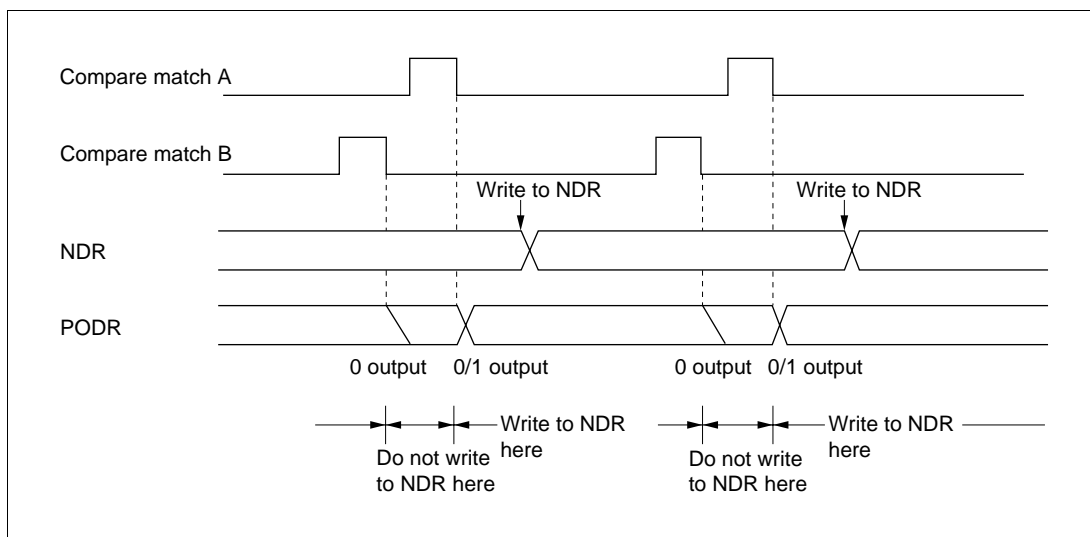
**Figure 12-10 Non-Overlapping Pulse Output**



Therefore, 0 data can be transferred ahead of 1 data by making compare match B occur before compare match A. The NDR contents should not be altered during the interval from compare match B to compare match A (the non-overlap margin).

This can be accomplished by having the TGIA interrupt handling routine write the next data in NDR, or by having the TGIA interrupt activate the DTC or DMAC. Note, however, that the next data must be written before the next compare match B occurs.

Figure 12-11 shows the timing of this operation.



**Figure 12-11 Non-Overlapping Operation and NDR Write Timing**



## Section 13 8-Bit Timers (TMR)

(This function is not available in the H8S/2695)

### 13.1 Overview

The H8S/2633 Series includes an 8-bit timer module with four channels (TMR0, TMR1, TMR2, and TMR3). Each channel has an 8-bit counter (TCNT) and two time constant registers (TCORA and TCORB) that are constantly compared with the TCNT value to detect compare match events. The 8-bit timer module can thus be used for a variety of functions, including pulse output with an arbitrary duty cycle.

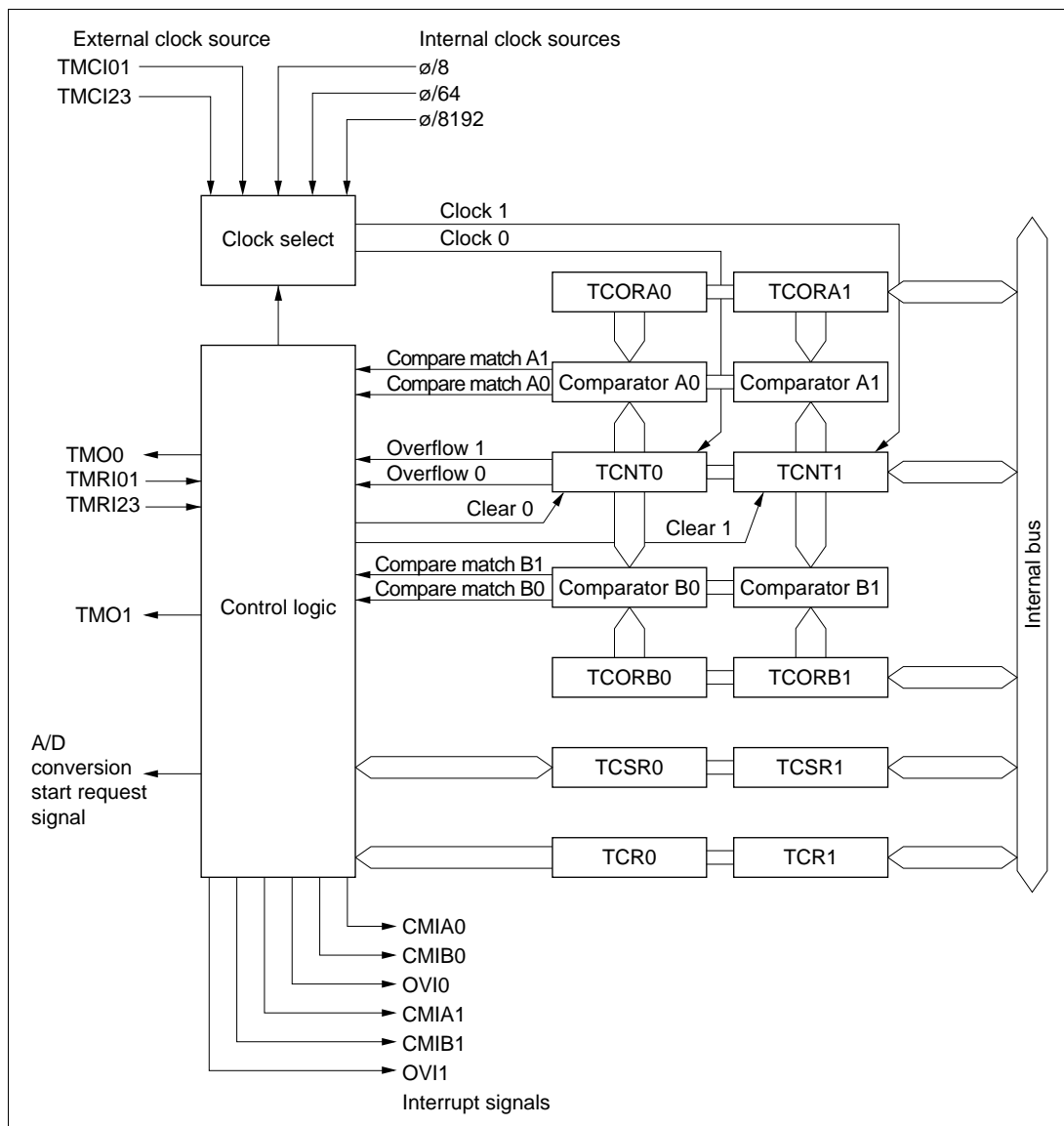
#### 13.1.1 Features

The features of the 8-bit timer module are listed below.

- Selection of four clock sources
  - The counters can be driven by one of three internal clock signals ( $\phi/8$ ,  $\phi/64$ , or  $\phi/8192$ ) or an external clock input (enabling use as an external event counter)
- Selection of three ways to clear the counters
  - The counters can be cleared on compare match A or B, or by an external reset signal
- Timer output control by a combination of two compare match signals
  - The timer output signal in each channel is controlled by a combination of two independent compare match signals, enabling the timer to generate output waveforms with an arbitrary duty cycle or PWM output
- Provision for cascading of two channels
  - Operation as a 16-bit timer is possible, using channel 0 (channel 2) for the upper 8 bits and channel 1 (channel 3) for the lower 8 bits (16-bit count mode)
  - Channel 1 (channel 3) can be used to count channel 0 (channel 2) compare matches (compare match count mode)
- Three independent interrupts
  - Compare match A and B and overflow interrupts can be requested independently
- A/D converter conversion start trigger can be generated
  - Channel 0 compare match A signal can be used as an A/D converter conversion start trigger
- Module stop mode can be set
  - As the initial setting, 8-bit timer operation is halted. Register access is enabled by exiting module stop mode

### 13.1.2 Block Diagram

Figure 13-1 shows a block diagram of the 8-bit timer module (TMR0, TMR1).



**Figure 13-1 Block Diagram of 8-Bit Timer**

### 13.1.3 Pin Configuration

Table 13-1 summarizes the input and output pins of the 8-bit timer.

**Table 13-1 Pin Configuration**

Channel	Name	Symbol	I/O	Function
0	Timer output pin 0	TMO0	Output	Outputs at compare match
	Timer clock input pin 01	TMCI01	Input	Inputs external clock for counter
	Timer reset input pin 01	TMRI01	Input	Inputs external reset to counter
1	Timer output pin 1	TMO1	Output	Outputs at compare match
	Timer clock input pin 23	TMCI23	Input	Inputs external clock for counter
	Timer reset input pin 23	TMRI23	Input	Inputs external reset to counter
2	Timer output pin 2	TMO2	Output	Outputs at compare match
	Timer clock input pin 23	TMCI23	Input	Inputs external clock for counter
	Timer reset input pin 23	TMRI23	Input	Inputs external reset to counter
3	Timer output pin 3	TMO3	Output	Outputs at compare match
	Timer clock input pin 01	TMCI01	Input	Inputs external clock for counter
	Timer reset input pin 01	TMRI01	Input	Inputs external reset to counter

### 13.1.4 Register Configuration

Table 13-2 summarizes the registers of the 8-bit timer module.

**Table 13-2 8-Bit Timer Registers**

Channel	Name	Abbreviation	R/W	Initial value	Address* <sup>1</sup>
0	Timer control register 0	TCR0	R/W	H'00	H'FF68
	Timer control/status register 0	TCSR0	R/(W)* <sup>2</sup>	H'00	H'FF6A
	Time constant register A0	TCORA0	R/W	H'FF	H'FF6C
	Time constant register B0	TCORB0	R/W	H'FF	H'FF6E
	Timer counter 0	TCNT0	R/W	H'00	H'FF70
1	Timer control register 1	TCR1	R/W	H'00	H'FF69
	Timer control/status register 1	TCSR1	R/(W)* <sup>2</sup>	H'10	H'FF6B
	Time constant register A1	TCORA1	R/W	H'FF	H'FF6D
	Time constant register B1	TCORB1	R/W	H'FF	H'FF6F
	Timer counter 1	TCNT1	R/W	H'00	H'FF71
2	Timer control register 2	TCR2	R/W	H'00	H'FDC0
	Timer control/status register 2	TCSR2	R/(W)* <sup>2</sup>	H'00	H'FDC2
	Time constant register A2	TCORA2	R/W	H'FF	H'FDC4
	Time constant register B2	TCORB2	R/W	H'FF	H'FDC6
	Timer counter 2	TCNT2	R/W	H'00	H'FDC8
3	Timer control register 3	TCR3	R/W	H'00	H'FDC1
	Timer control/status register 3	TCSR3	R/(W)* <sup>2</sup>	H'10	H'FDC3
	Time constant register A3	TCORA3	R/W	H'FF	H'FDC5
	Time constant register B3	TCORB3	R/W	H'FF	H'FDC7
	Timer counter 3	TCNT3	R/W	H'00	H'FDC9
All	Module stop control register A	MSTPCRA	R/W	H'3F	H'FDE8

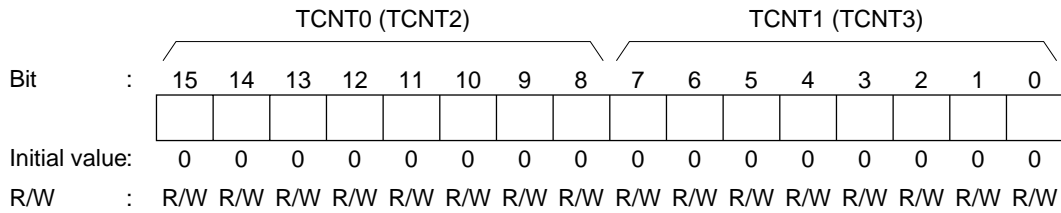
Notes: \*1 Lower 16 bits of the address

\*2 Only 0 can be written to bits 7 to 5, to clear these flags.

Each pair of registers for channel 0 (channel 2) and channel 1 (channel 3) is a 16-bit register with the upper 8 bits for channel 0 (channel 2) and the lower 8 bits for channel 1 (channel 3), so they can be accessed together by word transfer instruction.

## 13.2 Register Descriptions

### 13.2.1 Timer Counters 0 to 3 (TCNT0 to TCNT3)



TCNT0 to TCNT3 are 8-bit readable/writable up-counters that increment on pulses generated from an internal or external clock source. This clock source is selected by clock select bits CKS2 to CKS0 of TCR. The CPU can read or write to TCNT0 to TCNT3 at all times.

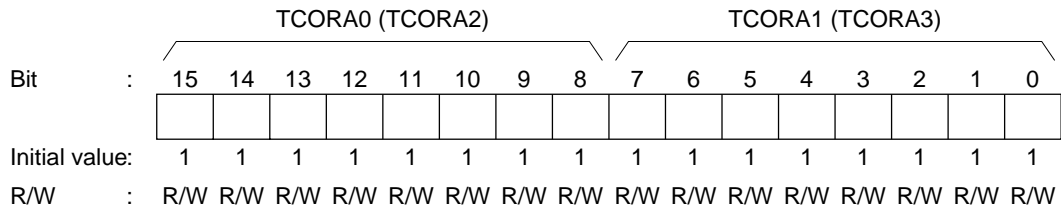
TCNT0 and TCNT1 (TCNT2 and TCNT3) comprise a single 16-bit register, so they can be accessed together by word transfer instruction.

TCNT0 and TCNT1 (TCNT2 and TCNT3) can be cleared by an external reset input or by a compare match signal. Which signal is to be used for clearing is selected by clock clear bits CCLR1 and CCLR0 of TCR.

When a timer counter overflows from H'FF to H'00, OVF in TCSR is set to 1.

TCNT0 and TCNT1 are each initialized to H'00 by a reset and in hardware standby mode.

### 13.2.2 Time Constant Registers A0 to A3 (TCORA0 to TCORA3)



TCORA0 to TCORA3 are 8-bit readable/writable registers. TCORA0 and TCORA1 (TCORA2 and TCORA3) comprise a single 16-bit register so they can be accessed together by word transfer instruction.

TCORA is continually compared with the value in TCNT. When a match is detected, the corresponding CMFA flag of TCSR is set. Note, however, that comparison is disabled during the T2 state of a TCOR write cycle.

The timer output can be freely controlled by these compare match signals and the settings of bits OS1 and OS0 of TCSR.

TCORA0 and TCORA1 are each initialized to H'FF by a reset and in hardware standby mode.

### 13.2.3 Time Constant Registers B0 to B3 (TCORB0 to TCORB3)

	<div style="display: flex; justify-content: space-around; width: 100%;"> <span>TCORB0 (TCORB2)</span> <span>TCORB1 (TCORB3)</span> </div>																
Bit	<div style="display: flex; justify-content: space-between; width: 100%;"> <span>15</span><span>14</span><span>13</span><span>12</span><span>11</span><span>10</span><span>9</span><span>8</span> <span>7</span><span>6</span><span>5</span><span>4</span><span>3</span><span>2</span><span>1</span><span>0</span> </div>																
	<table style="width: 100%; height: 20px; border-collapse: collapse;"> <tr> <td style="width: 12.5%;"></td><td style="width: 12.5%;"></td><td style="width: 12.5%;"></td><td style="width: 12.5%;"></td><td style="width: 12.5%;"></td><td style="width: 12.5%;"></td><td style="width: 12.5%;"></td><td style="width: 12.5%;"></td><td style="width: 12.5%;"></td><td style="width: 12.5%;"></td><td style="width: 12.5%;"></td><td style="width: 12.5%;"></td><td style="width: 12.5%;"></td><td style="width: 12.5%;"></td><td style="width: 12.5%;"></td><td style="width: 12.5%;"></td> </tr> </table>																
Initial value:	<table style="width: 100%; border-collapse: collapse;"> <tr> <td style="width: 12.5%;">1</td><td style="width: 12.5%;">1</td><td style="width: 12.5%;">1</td><td style="width: 12.5%;">1</td><td style="width: 12.5%;">1</td><td style="width: 12.5%;">1</td><td style="width: 12.5%;">1</td><td style="width: 12.5%;">1</td><td style="width: 12.5%;">1</td><td style="width: 12.5%;">1</td><td style="width: 12.5%;">1</td><td style="width: 12.5%;">1</td><td style="width: 12.5%;">1</td><td style="width: 12.5%;">1</td><td style="width: 12.5%;">1</td><td style="width: 12.5%;">1</td> </tr> </table>	1	1	1	1	1	1	1	1	1	1	1	1	1	1	1	1
1	1	1	1	1	1	1	1	1	1	1	1	1	1	1	1		
R/W	<table style="width: 100%; border-collapse: collapse;"> <tr> <td style="width: 12.5%;">R/W</td><td style="width: 12.5%;">R/W</td><td style="width: 12.5%;">R/W</td><td style="width: 12.5%;">R/W</td><td style="width: 12.5%;">R/W</td><td style="width: 12.5%;">R/W</td><td style="width: 12.5%;">R/W</td><td style="width: 12.5%;">R/W</td><td style="width: 12.5%;">R/W</td><td style="width: 12.5%;">R/W</td><td style="width: 12.5%;">R/W</td><td style="width: 12.5%;">R/W</td><td style="width: 12.5%;">R/W</td><td style="width: 12.5%;">R/W</td><td style="width: 12.5%;">R/W</td><td style="width: 12.5%;">R/W</td> </tr> </table>	R/W	R/W	R/W	R/W	R/W	R/W	R/W	R/W	R/W	R/W	R/W	R/W	R/W	R/W	R/W	R/W
R/W	R/W	R/W	R/W	R/W	R/W	R/W	R/W	R/W	R/W	R/W	R/W	R/W	R/W	R/W	R/W		

TCORB0 to TCORB3 are 8-bit readable/writable registers. TCORB0 and TCORB1 (TCORB2 and TCORB3) comprise a single 16-bit register so they can be accessed together by word transfer instruction.

TCORB is continually compared with the value in TCNT. When a match is detected, the corresponding CMFB flag of TCSR is set. Note, however, that comparison is disabled during the T2 state of a TCOR write cycle.

The timer output can be freely controlled by these compare match signals and the settings of output select bits OS3 and OS2 of TCSR.

TCORB0 and TCORB1 are each initialized to H'FF by a reset and in hardware standby mode.

### 13.2.4 Timer Control Registers 0 to 3 (TCR0 to TCR3)

	<div style="display: flex; justify-content: space-around; width: 100%;"> <span>7</span><span>6</span><span>5</span><span>4</span><span>3</span><span>2</span><span>1</span><span>0</span> </div>								
Bit	<table style="width: 100%; border-collapse: collapse;"> <tr> <td style="width: 12.5%; border: 1px solid black;">CMIEB</td><td style="width: 12.5%; border: 1px solid black;">CMIEA</td><td style="width: 12.5%; border: 1px solid black;">OVIE</td><td style="width: 12.5%; border: 1px solid black;">CCLR1</td><td style="width: 12.5%; border: 1px solid black;">CCLR0</td><td style="width: 12.5%; border: 1px solid black;">CKS2</td><td style="width: 12.5%; border: 1px solid black;">CKS1</td><td style="width: 12.5%; border: 1px solid black;">CKS0</td> </tr> </table>	CMIEB	CMIEA	OVIE	CCLR1	CCLR0	CKS2	CKS1	CKS0
CMIEB	CMIEA	OVIE	CCLR1	CCLR0	CKS2	CKS1	CKS0		
Initial value:	<table style="width: 100%; border-collapse: collapse;"> <tr> <td style="width: 12.5%;">0</td><td style="width: 12.5%;">0</td><td style="width: 12.5%;">0</td><td style="width: 12.5%;">0</td><td style="width: 12.5%;">0</td><td style="width: 12.5%;">0</td><td style="width: 12.5%;">0</td><td style="width: 12.5%;">0</td> </tr> </table>	0	0	0	0	0	0	0	0
0	0	0	0	0	0	0	0		
R/W	<table style="width: 100%; border-collapse: collapse;"> <tr> <td style="width: 12.5%;">R/W</td><td style="width: 12.5%;">R/W</td><td style="width: 12.5%;">R/W</td><td style="width: 12.5%;">R/W</td><td style="width: 12.5%;">R/W</td><td style="width: 12.5%;">R/W</td><td style="width: 12.5%;">R/W</td><td style="width: 12.5%;">R/W</td> </tr> </table>	R/W	R/W	R/W	R/W	R/W	R/W	R/W	R/W
R/W	R/W	R/W	R/W	R/W	R/W	R/W	R/W		

TCR0 to TCR3 are 8-bit readable/writable registers that select the input clock source and the time at which TCNT is cleared, and enable interrupts.

TCR0 and TCR1 are each initialized to H'00 by a reset and in hardware standby mode.

For details of this timing, see section 13.3, Operation.



**Bit 7—Compare Match Interrupt Enable B (CMIEB):** Selects whether CMFB interrupt requests (CMIB) are enabled or disabled when the CMFB flag of TCSR is set to 1.

**Bit 7**

CMIEB	Description
0	CMFB interrupt requests (CMIB) are disabled (Initial value)
1	CMFB interrupt requests (CMIB) are enabled

**Bit 6—Compare Match Interrupt Enable A (CMIEA):** Selects whether CMFA interrupt requests (CMIA) are enabled or disabled when the CMFA flag of TCSR is set to 1.

**Bit 6**

CMIEA	Description
0	CMFA interrupt requests (CMIA) are disabled (Initial value)
1	CMFA interrupt requests (CMIA) are enabled

**Bit 5—Timer Overflow Interrupt Enable (OVIE):** Selects whether OVF interrupt requests (OVI) are enabled or disabled when the OVF flag of TCSR is set to 1.

**Bit 5**

OVIE	Description
0	OVF interrupt requests (OVI) are disabled (Initial value)
1	OVF interrupt requests (OVI) are enabled

**Bits 4 and 3—Counter Clear 1 and 0 (CCLR1 and CCLR0):** These bits select the method by which TCNT is cleared: by compare match A or B, or by an external reset input.

Bit 4	Bit 3	Description
CCLR1	CCLR0	
0	0	Clear is disabled (Initial value)
	1	Clear by compare match A
1	0	Clear by compare match B
	1	Clear by rising edge of external reset input

**Bits 2 to 0—Clock Select 2 to 0 (CKS2 to CKS0):** These bits select whether the clock input to TCNT is an internal or external clock.

Three internal clocks can be selected, all divided from the system clock ( $\phi$ ):  $\phi/8$ ,  $\phi/64$ , and  $\phi/8192$ . The falling edge of the selected internal clock triggers the count.

When use of an external clock is selected, three types of count can be selected: at the rising edge, the falling edge, and both rising and falling edges.

Some functions differ between channel 0 and channel 1.

Bit 2	Bit 1	Bit 0	Description
CKS2	CKS1	CKS0	
0	0	0	Clock input disabled (Initial value)
		1	Internal clock, counted at falling edge of $\phi/8$
	1	0	Internal clock, counted at falling edge of $\phi/64$
		1	Internal clock, counted at falling edge of $\phi/8192$
1	0	0	For channel 0: count at TCNT1 overflow signal* For channel 1: count at TCNT0 compare match A* For channel 2: count at TCNT3 overflow signal* For channel 3: count at TCNT2 compare match A*
		1	External clock, counted at rising edge
	1	0	External clock, counted at falling edge
		1	External clock, counted at both rising and falling edges

Note: \* If the count input of channel 0 (channel 2) is the TCNT1 (TCNT3) overflow signal and that of channel 1 (channel 3) is the TCNT0 (TCNT2) compare match signal, no incrementing clock is generated. Do not use this setting.

### 13.2.5 Timer Control/Status Registers 0 to 3 (TCSR0 to TCSR3)

#### TCSR0

Bit	:	7	6	5	4	3	2	1	0
		CMFB	CMFA	OVF	ADTE	OS3	OS2	OS1	OS0
Initial value:		0	0	0	0	0	0	0	0
R/W	:	R/(W)*	R/(W)*	R/(W)*	R/W	R/W	R/W	R/W	R/W

#### TCSR1, TCSR3

Bit	:	7	6	5	4	3	2	1	0
		CMFB	CMFA	OVF	—	OS3	OS2	OS1	OS0
Initial value:		0	0	0	1	0	0	0	0
R/W	:	R/(W)*	R/(W)*	R/(W)*	—	R/W	R/W	R/W	R/W

#### TCSR2

Bit	:	7	6	5	4	3	2	1	0
		CMFB	CMFA	OVF	—	OS3	OS2	OS1	OS0
Initial value:		0	0	0	0	0	0	0	0
R/W	:	R/(W)*	R/(W)*	R/(W)*	R/W	R/W	R/W	R/W	R/W

Note: \* Only 0 can be written to bits 7 to 5, to clear these flags.

TCSR0 to TCSR3 are 8-bit registers that display compare match and timer overflow statuses, and control compare match output.

TCSR0 and TCSR2 are initialized to H'00, and TCSR1 and TCSR3 to H'10, by a reset and in hardware standby mode.

**Bit 7—Compare Match Flag B (CMFB):** Status flag indicating whether the values of TCNT and TCORB match.

**Bit 7**

CMFB	Description
0	[Clearing conditions] (Initial value) <ul style="list-style-type: none"> <li>• Cleared by reading CMFB when CMFB = 1, then writing 0 to CMFB</li> <li>• When DTC is activated by CMIB interrupt while DISEL bit of MRB in DTC is 0</li> </ul>
1	[Setting condition] Set when TCNT matches TCORB

**Bit 6—Compare Match Flag A (CMFA):** Status flag indicating whether the values of TCNT and TCORA match.

**Bit 6**

CMFA	Description
0	[Clearing conditions] (Initial value) <ul style="list-style-type: none"> <li>• Cleared by reading CMFA when CMFA = 1, then writing 0 to CMFA</li> <li>• When DTC is activated by CMIA interrupt while DISEL bit of MRB in DTC is 0</li> </ul>
1	[Setting condition] Set when TCNT matches TCORA

**Bit 5—Timer Overflow Flag (OVF):** Status flag indicating that TCNT has overflowed (changed from H'FF to H'00).

**Bit 5**

OVF	Description
0	[Clearing condition] (Initial value) Cleared by reading OVF when OVF = 1, then writing 0 to OVF
1	[Setting condition] Set when TCNT overflows from H'FF to H'00

**Bit 4—A/D Trigger Enable (ADTE) (TCSR0 Only):** Selects enabling or disabling of A/D converter start requests by compare-match A.

TCSR1 to TCSR3 are reserved bits. When TCSR1 and TCSR3 are read, always 1 is read off. Write is disabled. TCSR2 is readable/writable.

**Bit 4**

ADTE	Description
0	A/D converter start requests by compare match A are disabled (Initial value)
1	A/D converter start requests by compare match A are enabled

**Bits 3 to 0—Output Select 3 to 0 (OS3 to OS0):** These bits specify how the timer output level is to be changed by a compare match of TCOR and TCNT.

Bits OS3 and OS2 select the effect of compare match B on the output level, bits OS1 and OS0 select the effect of compare match A on the output level, and both of them can be controlled independently.

Note, however, that priorities are set such that: toggle output > 1 output > 0 output. If compare matches occur simultaneously, the output changes according to the compare match with the higher priority.

Timer output is disabled when bits OS3 to OS0 are all 0.

After a reset, the timer output is 0 until the first compare match event occurs.

Bit 3	Bit 2	Description
OS3	OS2	
0	0	No change when compare match B occurs (Initial value)
	1	0 is output when compare match B occurs
1	0	1 is output when compare match B occurs
	1	Output is inverted when compare match B occurs (toggle output)

Bit 1	Bit 0	Description
OS1	OS0	
0	0	No change when compare match A occurs (Initial value)
	1	0 is output when compare match A occurs
1	0	1 is output when compare match A occurs
	1	Output is inverted when compare match A occurs (toggle output)

### 13.2.6 Module Stop Control Register A (MSTPCRA)

Bit	:	7	6	5	4	3	2	1	0
		MSTPA7	MSTPA6	MSTPA5	MSTPA4	MSTPA3	MSTPA2	MSTPA1	MSTPA0
Initial value	:	0	0	1	1	1	1	1	1
R/W	:	R/W	R/W	R/W	R/W	R/W	R/W	R/W	R/W

MSTPCRA is an 8-bit readable/writable register that performs module stop mode control.

When the MSTPA4 and MSTPA0 bits in MSTPCR is set to 1, the 8-bit timer operation stops at the end of the bus cycle and a transition is made to module stop mode. For details, see section 24.5, Module Stop Mode.

MSTPCRA is initialized to H'3F by a power-on reset and in hardware standby mode. It is not initialized by a manual reset and in software standby mode.

**Bit 4—Module Stop (MSTPA4):** Specifies the TMR0 and TMR1 module stop mode.

#### Bit 4

MSTPA4	Description
0	TMR0, TMR1 module stop mode cleared
1	TMR0, TMR1 module stop mode set (Initial value)

**Bit 0—Module Stop (MSTPA0):** Specifies the TMR2 and TMR3 module stop mode.

#### Bit 0

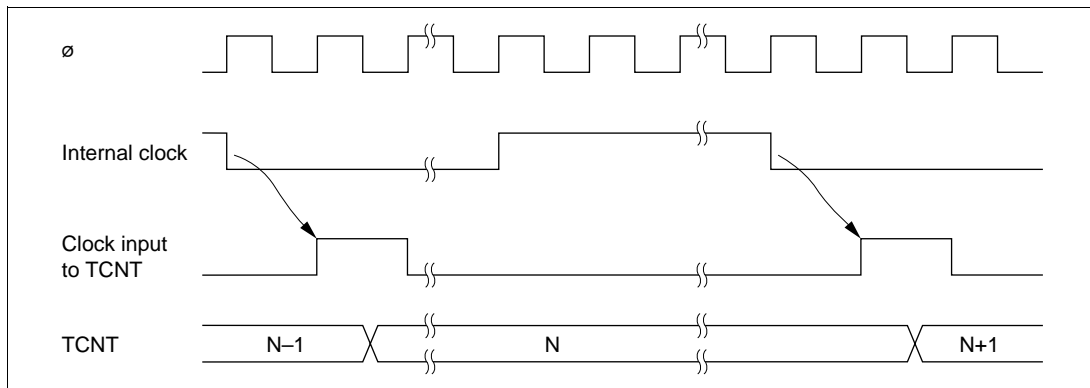
MSTPA0	Description
0	TMR2, TMR3 module stop mode cleared
1	TMR2, TMR3 module stop mode set (Initial value)

## 13.3 Operation

### 13.3.1 TCNT Incrementation Timing

TCNT is incremented by input clock pulses (either internal or external).

**Internal Clock:** Three different internal clock signals ( $\phi/8$ ,  $\phi/64$ , or  $\phi/8192$ ) divided from the system clock ( $\phi$ ) can be selected, by setting bits CKS2 to CKS0 in TCR. Figure 13-2 shows the count timing.

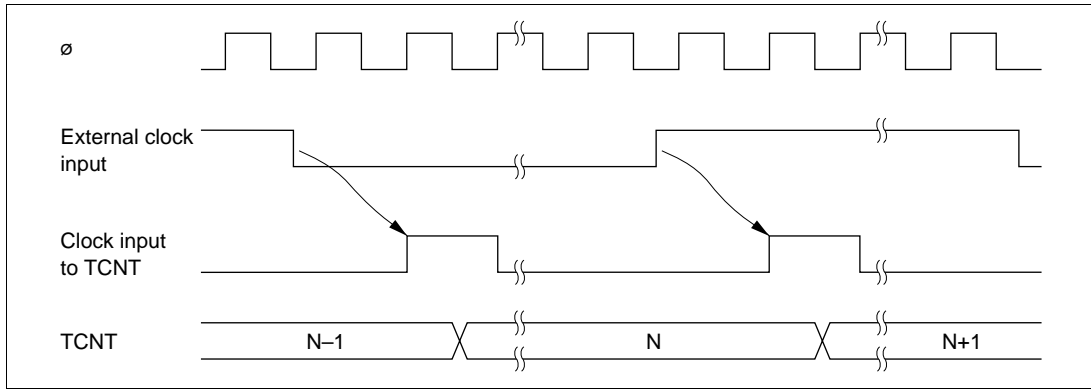


**Figure 13-2 Count Timing for Internal Clock Input**

**External Clock:** Three incrementation methods can be selected by setting bits CKS2 to CKS0 in TCR: at the rising edge, the falling edge, and both rising and falling edges.

Note that the external clock pulse width must be at least 1.5 states for incrementation at a single edge, and at least 2.5 states for incrementation at both edges. The counter will not increment correctly if the pulse width is less than these values.

Figure 13-3 shows the timing of incrementation at both edges of an external clock signal.

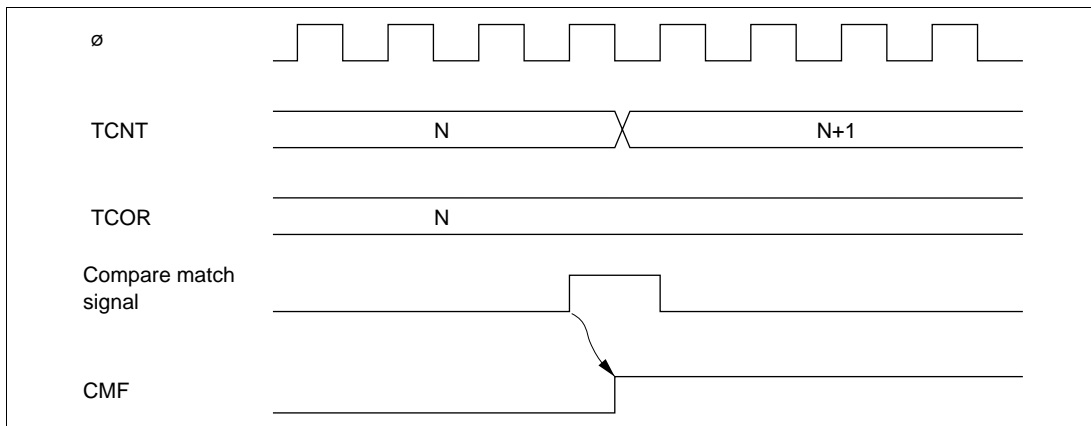


**Figure 13-3 Count Timing for External Clock Input**

### 13.3.2 Compare Match Timing

**Setting of Compare Match Flags A and B (CMFA, CMFB):** The CMFA and CMFB flags in TCSR are set to 1 by a compare match signal generated when the TCOR and TCNT values match. The compare match signal is generated at the last state in which the match is true, just before the timer counter is updated.

Therefore, when TCOR and TCNT match, the compare match signal is not generated until the next incrementation clock input. Figure 13-4 shows this timing.

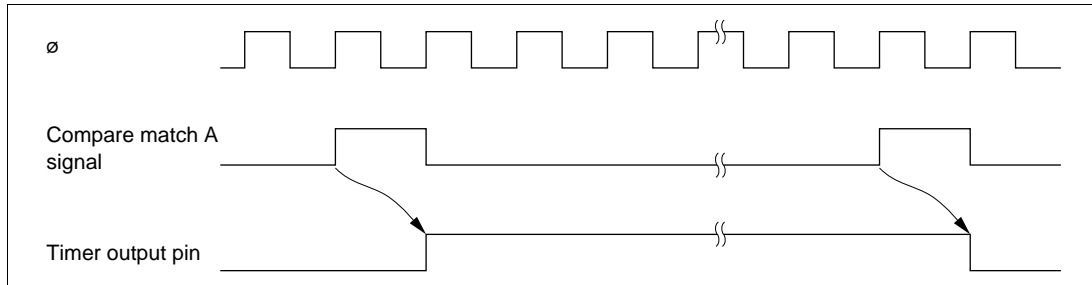


**Figure 13-4 Timing of CMF Setting**



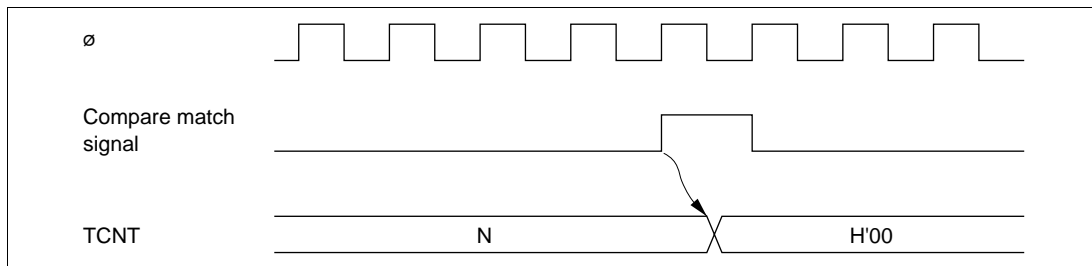
**Timer Output Timing:** When compare match A or B occurs, the timer output changes a specified by bits OS3 to OS0 in TCSR. Depending on these bits, the output can remain the same, change to 0, change to 1, or toggle.

Figure 13-5 shows the timing when the output is set to toggle at compare match A.



**Figure 13-5 Timing of Timer Output**

**Timing of Compare Match Clear:** The timer counter is cleared when compare match A or B occurs, depending on the setting of the CCLR1 and CCLR0 bits in TCR. Figure 13-6 shows the timing of this operation.



**Figure 13-6 Timing of Compare Match Clear**

### 13.3.3 Timing of External RESET on TCNT

TCNT is cleared at the rising edge of an external reset input, depending on the settings of the CCLR1 and CCLR0 bits in TCR. The clear pulse width must be at least 1.5 states. Figure 13-7 shows the timing of this operation.

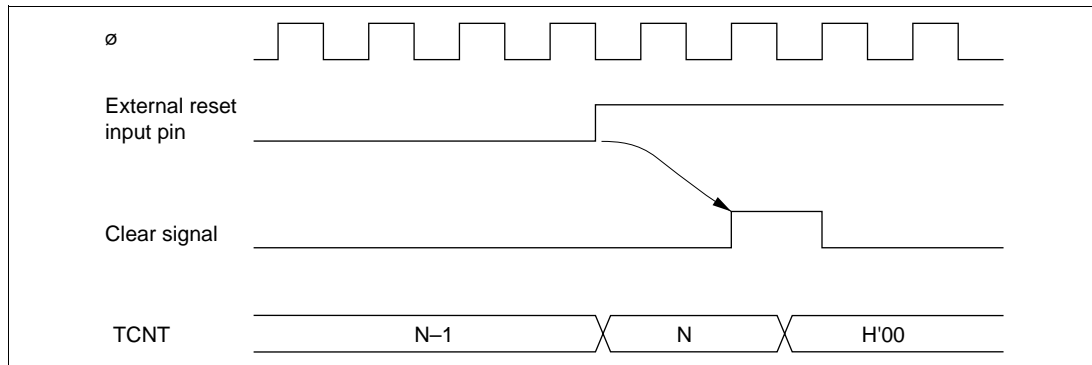


Figure 13-7 Timing of External Reset

### 13.3.4 Timing of Overflow Flag (OVF) Setting

The OVF in TCSR is set to 1 when the timer count overflows (changes from H'FF to H'00). Figure 13-8 shows the timing of this operation.

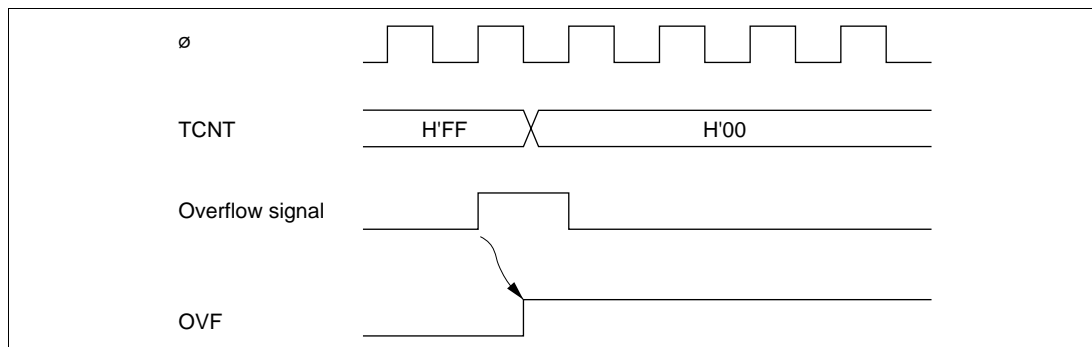


Figure 13-8 Timing of OVF Setting

### 13.3.5 Operation with Cascaded Connection

If bits CKS2 to CKS0 in either TCR0 or TCR1 are set to B'100, the 8-bit timers of the two channels are cascaded. With this configuration, a single 16-bit timer could be used (16-bit timer mode) or compare matches of the 8-bit timer channel 0 (channel 2) could be counted by the timer of channel 1 (channel 3) (compare match counter mode). In this case, the timer operates as below.

**16-Bit Counter Mode:** When bits CKS2 to CKS0 in TCR0 are set to B'100, the timer functions as a single 16-bit timer with channel 0 (channel 2) occupying the upper 8 bits and channel 1 (channel 3) occupying the lower 8 bits.

- Setting of compare match flags
  - The CMF flag in TCSR0 and TCSR2 is set to 1 when a 16-bit compare match event occurs
  - The CMF flag in TCSR1 and TCSR3 is set to 1 when a lower 8-bit compare match event occurs
- Counter clear specification
  - If the CCLR1 and CCLR0 bits in TCR0 (TCR2) have been set for counter clear at compare match, the 16-bit counter (TCNT0 and TCNT1 (TCNT2 and TCNT3) together) is cleared when a 16-bit compare match event occurs. The 16-bit counter (TCNT0 and TCNT1 (TCNT2 and TCNT3) together) is cleared even if counter clear by the TMRI01 (TMRI23) pin has also been set
  - The settings of the CCLR1 and CCLR0 bits in TCR1 and TCR3 are ignored. The lower 8 bits cannot be cleared independently
- Pin output
  - Control of output from the TMO0 (TMO2) pin by bits OS3 to OS0 in TCSR0 (TCSR2) is in accordance with the 16-bit compare match conditions
  - Control of output from the TMO1 (TMO3) pin by bits OS3 to OS0 in TCSR1 (TCSR3) is in accordance with the lower 8-bit compare match conditions

**Compare Match Counter Mode:** When bits CKS2 to CKS0 in TCR1 (TCR3) are B'100, TCNT1 (TCNT3) counts compare match A's for channel 0 (channel 2).

Channels 0 to 3 are controlled independently. Conditions such as setting of the CMF flag, generation of interrupts, output from the TMO pin, and counter clear are in accordance with the settings for each channel.

**Note on Usage:** If the 16-bit counter mode and compare match counter mode are set simultaneously, the input clock pulses for TCNT0 and TCNT1 (TCNT2 and TCNT3) are not generated and thus the counters will stop operating. Software should therefore avoid using both these modes.


## 13.4 Interrupts

### 13.4.1 Interrupt Sources and DTC Activation

(The H8S/2695 does not have a DTC function or an 8-bit timer)

There are three 8-bit timer interrupt sources: CMIA, CMIB, and OVI. Their relative priorities are shown in table 13-3. Each interrupt source is set as enabled or disabled by the corresponding interrupt enable bit in TCR, and independent interrupt requests are sent for each to the interrupt controller. It is also possible to activate the DTC by means of CMIA and CMIB interrupts.

**Table 13-3 8-Bit Timer Interrupt Sources**

Channel	Interrupt Source	Description	DTC Activation	Priority
0	CMIA0	Interrupt by CMFA	Possible	
	CMIB0	Interrupt by CMFB	Possible	
	OVI0	Interrupt by OVF	Not possible	
1	CMIA1	Interrupt by CMFA	Possible	
	CMIB1	Interrupt by CMFB	Possible	
	OVI1	Interrupt by OVF	Not possible	
2	CMIA2	Interrupt by CMFA	Possible	
	CMIB2	Interrupt by CMFB	Possible	
	OVI2	Interrupt by OVF	Not possible	
3	CMIA3	Interrupt by CMFA	Possible	
	CMIB3	Interrupt by CMFB	Possible	
	OVI3	Interrupt by OVF	Not possible	

Note: This table shows the initial state immediately after a reset. The relative channel priorities can be changed by the interrupt controller.

### 13.4.2 A/D Converter Activation

The A/D converter can be activated only by channel 0 compare match A.

If the ADTE bit in TCSR0 is set to 1 when the CMFA flag is set to 1 by the occurrence of channel 0 compare match A, a request to start A/D conversion is sent to the A/D converter. If the 8-bit timer conversion start trigger has been selected on the A/D converter side at this time, A/D conversion is started.

### 13.5 Sample Application

In the example below, the 8-bit timer is used to generate a pulse output with a selected duty cycle, as shown in figure 13-9. The control bits are set as follows:

- [1] In TCR, bit CCLR1 is cleared to 0 and bit CCLR0 is set to 1 so that TCNT is cleared by comparing and matching TCORA.
- [2] In TCSR, bits OS3 to OS0 are set to B'0110, causing the output to change to 1 at a TCORA compare match and to 0 at a TCORB compare match.

With these settings, the 8-bit timer provides output of pulses at a rate determined by TCORA with a pulse width determined by TCORB. No software intervention is required.

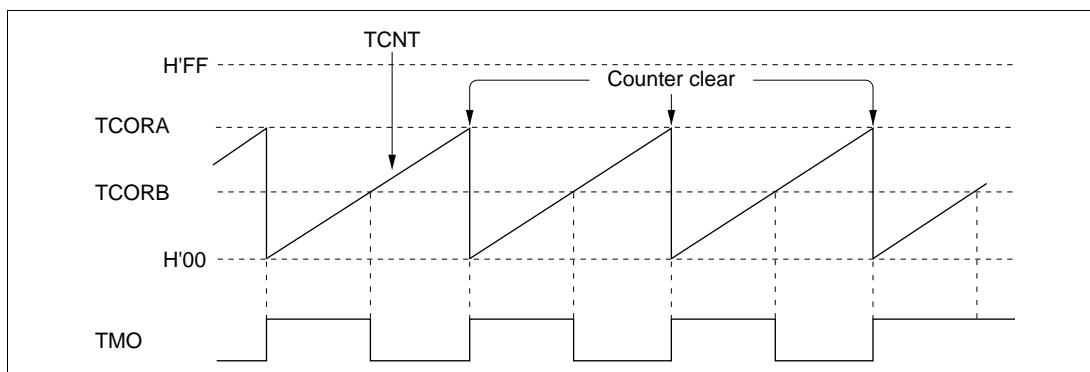


Figure 13-9 Example of Pulse Output

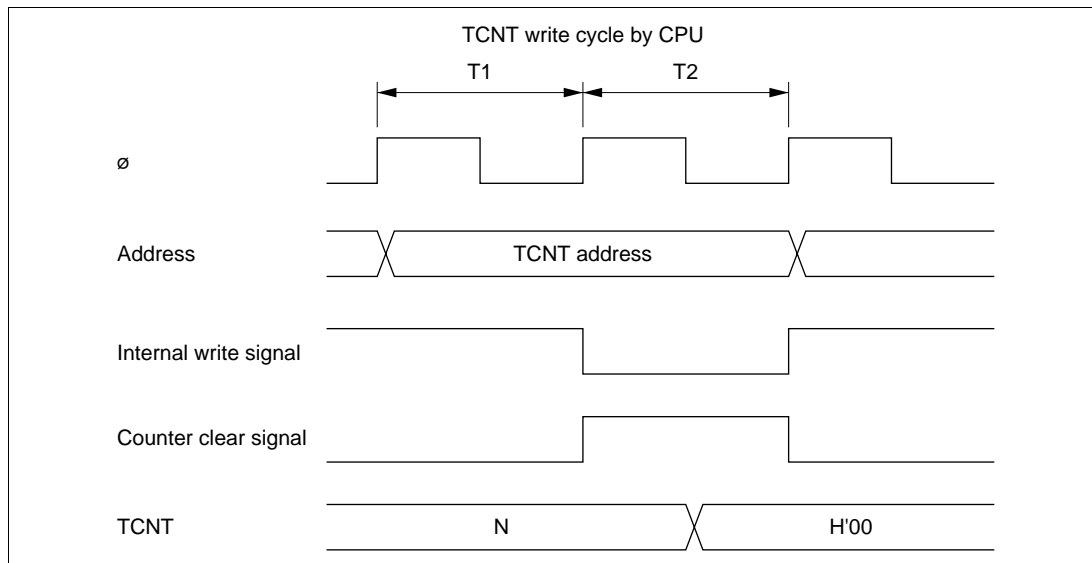
## 13.6 Usage Notes

Application programmers should note that the following kinds of contention can occur in the 8-bit timer.

### 13.6.1 Contention between TCNT Write and Clear

If a timer counter clock pulse is generated during the T2 state of a TCNT write cycle, the clear takes priority, so that the counter is cleared and the write is not performed.

Figure 13-10 shows this operation.

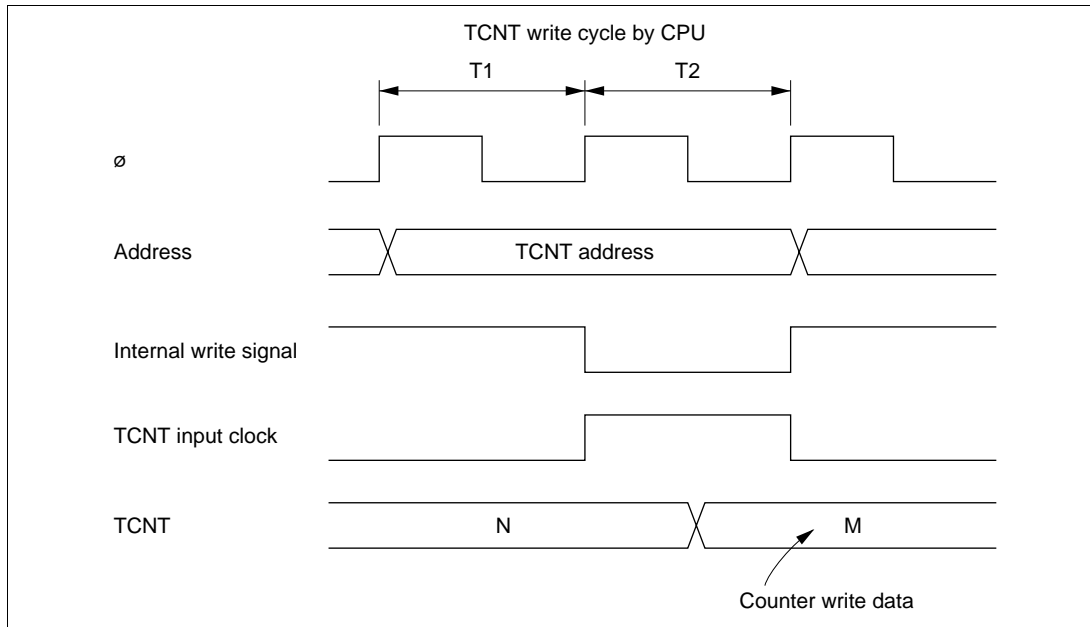


**Figure 13-10 Contention between TCNT Write and Clear**

### 13.6.2 Contention between TCNT Write and Increment

If a timer counter clock pulse is generated during the T2 state of a TCNT write cycle, the write takes priority and the counter is not incremented.

Figure 13-11 shows this operation.

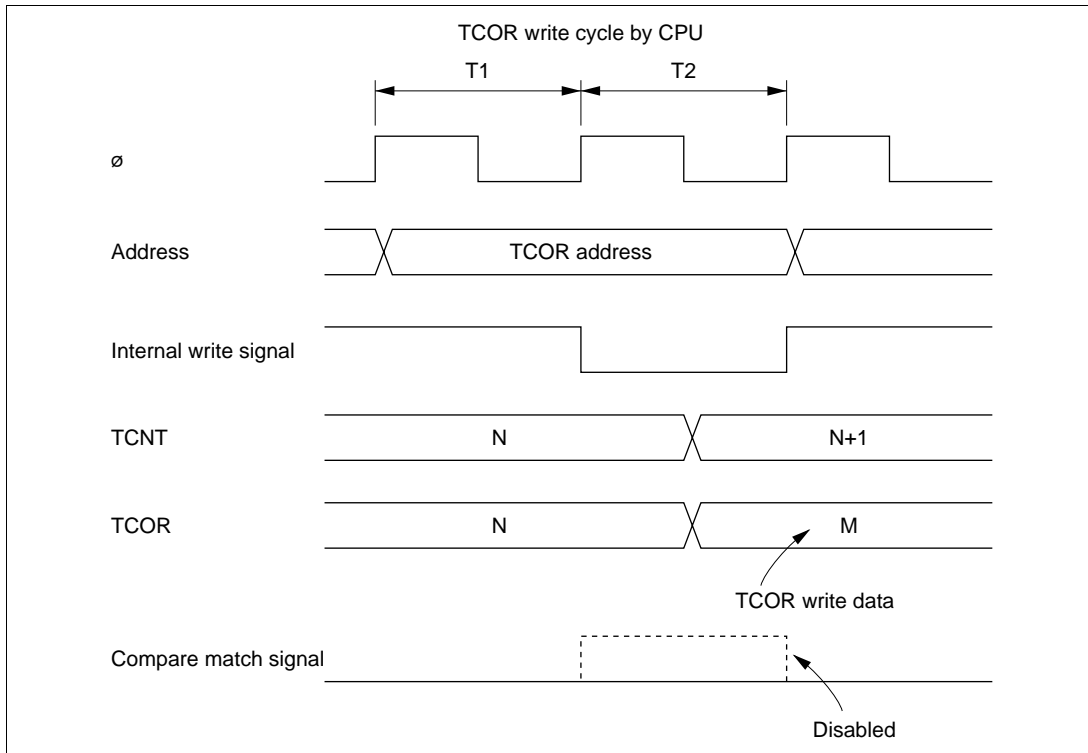


**Figure 13-11 Contention between TCNT Write and Increment**

### 13.6.3 Contention between TCOR Write and Compare Match

During the T2 state of a TCOR write cycle, the TCOR write has priority and the compare match signal is disabled even if a compare match event occurs.

Figure 13-12 shows this operation.



**Figure 13-12 Contention between TCOR Write and Compare Match**



### 13.6.4 Contention between Compare Matches A and B

If compare match events A and B occur at the same time, the 8-bit timer operates in accordance with the priorities for the output statuses set for compare match A and compare match B, as shown in table 13-4.

**Table 13-4 Timer Output Priorities**

Output Setting	Priority
Toggle output	High
1 output	↑
0 output	↓
No change	Low

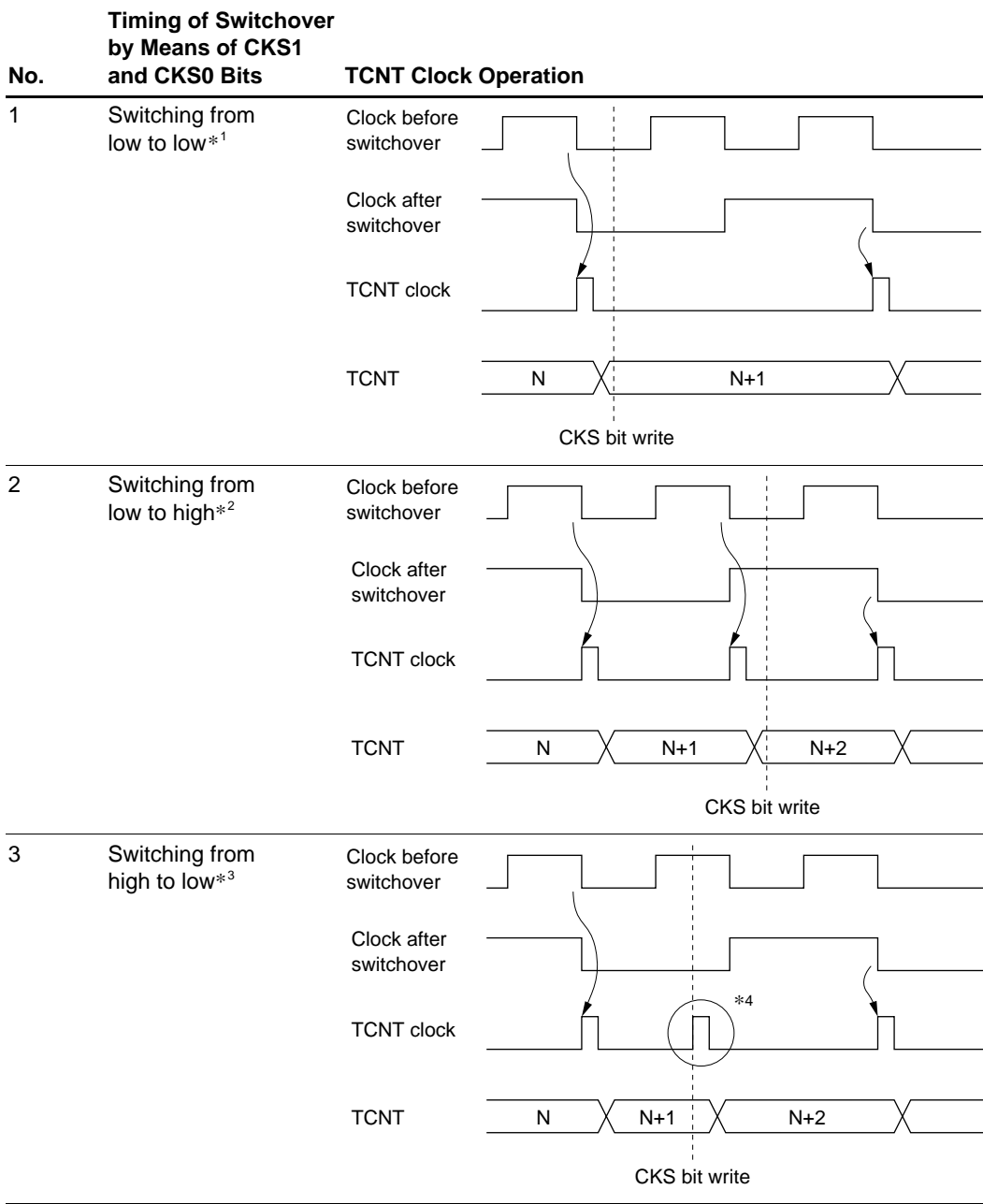
### 13.6.5 Switching of Internal Clocks and TCNT Operation

TCNT may increment erroneously when the internal clock is switched over. Table 13-5 shows the relationship between the timing at which the internal clock is switched (by writing to the CKS1 and CKS0 bits) and the TCNT operation.

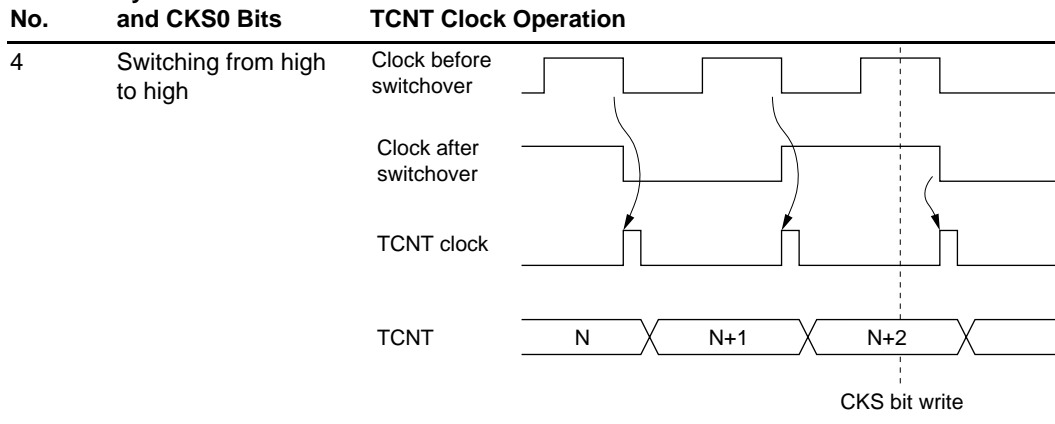
When the TCNT clock is generated from an internal clock, the falling edge of the internal clock pulse is detected. If clock switching causes a change from high to low level, as shown in case 3 in table 13-5, a TCNT clock pulse is generated on the assumption that the switchover is a falling edge. This increments TCNT.

The erroneous incrementation can also happen when switching between internal and external clocks.

**Table 13-5 Switching of Internal Clock and TCNT Operation**



**Timing of Switchover  
by Means of CKS1  
and CKS0 Bits**



- Notes:
- \*1 Includes switching from low to stop, and from stop to low.
  - \*2 Includes switching from stop to high.
  - \*3 Includes switching from high to stop.
  - \*4 Generated on the assumption that the switchover is a falling edge; TCNT is incremented.

**13.6.6 Interrupts and Module Stop Mode**

If module stop mode is entered when an interrupt has been requested, it will not be possible to clear the CPU interrupt source or DMAC and DTC activation source. Interrupts should therefore be disabled before entering module stop mode.



## Section 14 14-Bit PWM D/A

(This function is not available in the H8S/2695)

### 14.1 Overview

The H8S/2633 Series has an on-chip 14-bit pulse-width modulator (PWM) with four output channels.

Each channel can be connected to an external low-pass filter to operate as a 14-bit D/A converter.

Both channels share the same counter (DACNT) and control register (DACR).

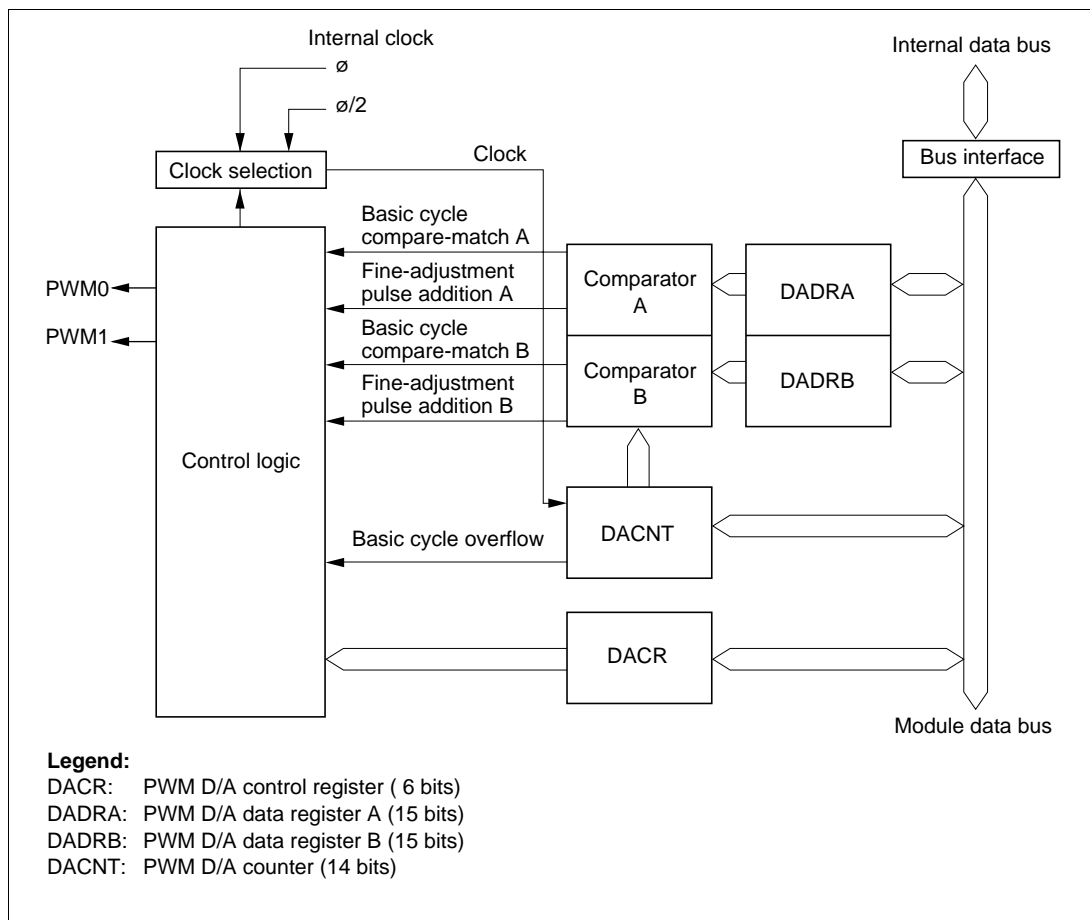
#### 14.1.1 Features

The features of the 14-bit PWM D/A are listed below.

- The pulse is subdivided into multiple base cycles to reduce ripple.
- Two resolution settings and two base cycle settings are available  
The resolution can be set equal to one or two system clock cycles. The base cycle can be set equal to  $T \times 64$  or  $T \times 256$ , where T is the resolution.
- Four operating rates  
The two resolution settings and two base cycle settings combine to give a selection of four operating rates.

### 14.1.2 Block Diagram

Figure 14-1 shows a block diagram of the PWM D/A module.



**Figure 14-1 PWM D/A Block Diagram**

### 14.1.3 Pin Configuration

Table 14-1 lists the pins used by the PWM D/A module.

**Table 14-1 Input and Output Pins**

Name	Abbr.	I/O	Function
PWM output pin 0	PWM0	Output	PWM output, channel 0A
PWM output pin 1	PWM1	Output	PWM output, channel 0B
PWM output pin 2	PWM2	Output	PWM output, channel 1A
PWM output pin 3	PWM3	Output	PWM output, channel 1B

### 14.1.4 Register Configuration

Table 14-2 lists the registers of the PWM D/A module.

**Table 14-2 Register Configuration**

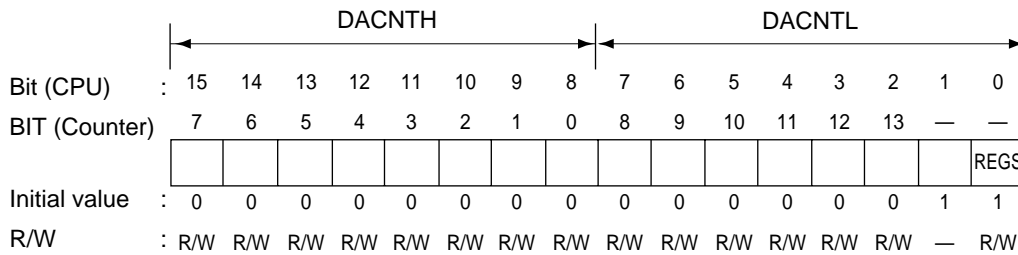
Channel	Name	Abbreviation	R/W	Initial value	Address* <sup>1</sup>
0	PWM D/A control register 0	DACR0	R/W	H'30	H'FDB8* <sup>2</sup>
	PWM D/A data register AH0	DADRAH0	R/W	H'FF	H'FDB8* <sup>2</sup>
	PWM D/A data register AL0	DADRAL0	R/W	H'FF	H'FDB9* <sup>2</sup>
	PWM D/A data register BH0	DADRBH0	R/W	H'FF	H'FDBA* <sup>2</sup>
	PWM D/A data register BL0	DADRBL0	R/W	H'FF	H'FDBB* <sup>2</sup>
	PWM D/A counter H0	DACNTH0	R/W	H'00	H'FDBA* <sup>2</sup>
	PWM D/A counter L0	DACNTL0	R/W	H'03	H'FDBB* <sup>2</sup>
1	PWM D/A control register 1	DACR1	R/W	H'30	H'FDBC* <sup>2</sup>
	PWM D/A data register AH1	DADRAH1	R/W	H'FF	H'FDBC* <sup>2</sup>
	PWM D/A data register AL1	DADRAL1	R/W	H'FF	H'FDBD* <sup>2</sup>
	PWM D/A data register BH1	DADRBH1	R/W	H'FF	H'FDBE* <sup>2</sup>
	PWM D/A data register BL1	DADRBL1	R/W	H'FF	H'FDBF* <sup>2</sup>
	PWM D/A counter H1	DACNTH1	R/W	H'00	H'FDBE* <sup>2</sup>
	PWM D/A counter L1	DACNTL1	R/W	H'03	H'FDBF* <sup>2</sup>
All	Module stop control register B	MSTPCRB	R/W	H'FF	H'FDE9

Notes: \*1 Lower 16 bits of the address.

\*2 The same addresses are shared by DADRA and DACR, and by DADRB and DACNT. Switching is performed by the REGS bit in DACNT or DADRB.

## 14.2 Register Descriptions

### 14.2.1 PWM D/A Counter (DACNT)



DACNT is a 14-bit readable/writable up-counter that increments on an input clock pulse. The input clock is selected by the clock select bit (CKS) in DACR. The CPU can read and write the DACNT value, but since DACNT is a 16-bit register, data transfers between it and the CPU are performed using a temporary register (TEMP). See section 14.3, Bus Master Interface, for details.

DACNT functions as the time base for both PWM D/A channels. When a channel operates with 14-bit precision, it uses all DACNT bits. When a channel operates with 12-bit precision, it uses the lower 12 (counter) bits and ignores the upper two (counter) bits.

DACNT is initialized to H'0003 by a reset, in the standby modes, watch mode, subactive mode, subsleep mode, and module stop mode, and by the PWME bit.

Bit 1 of DACNTL (CPU) is not used, and is always read as 1.

**DACNTL Bit 0—Register Select (REGS):** DADRA and DACR, and DADRb and DACNT, are located at the same addresses. The REGS bit specifies which registers can be accessed. The REGS bit can be accessed regardless of whether DADRb or DACNT is selected.

#### Bit 0

REGS	Description
0	DADRA and DADRb can be accessed
1	DACR and DACNT can be accessed <span style="float: right;">(Initial value)</span>



## 14.2.2 PWM D/A Data Registers A and B (DADRA and DADRB)

	DADRH								DADRL							
Bit (CPU)	15	14	13	12	11	10	9	8	7	6	5	4	3	2	1	0
Bit (Data)	13	12	11	10	9	8	7	6	5	4	3	2	1	0	—	—
DADRA	DA13	DA12	DA11	DA10	DA9	DA8	DA7	DA6	DA5	DA4	DA3	DA2	DA1	DA0	CFS	—
Initial value	1	1	1	1	1	1	1	1	1	1	1	1	1	1	1	1
R/W	R/W	R/W	R/W	R/W	R/W	R/W	R/W	R/W	R/W	R/W	R/W	R/W	R/W	R/W	R/W	—
DADRB	DA13	DA12	DA11	DA10	DA9	DA8	DA7	DA6	DA5	DA4	DA3	DA2	DA1	DA0	CFS	REGS
Initial value	1	1	1	1	1	1	1	1	1	1	1	1	1	1	1	1
R/W	R/W	R/W	R/W	R/W	R/W	R/W	R/W	R/W	R/W	R/W	R/W	R/W	R/W	R/W	R/W	R/W

There are two 16-bit readable/writable PWM D/A data registers: DADRA and DADRB. DADRA corresponds to PWM D/A channel A, and DADRB to PWM D/A channel B. The CPU can read and write the PWM D/A data register values, but since DADRA and DADRB are 16-bit registers, data transfers between them and the CPU are performed using a temporary register (TEMP). See section 14.3, Bus Master Interface, for details.

The least significant (CPU) bit of DADRA is not used and is always read as 1.

DADR is initialized to H'FFFF by a reset, and in the standby modes, watch mode, subactive mode, subsleep mode, and module stop mode.

**Bits 15 to 3—PWM D/A Data 13 to 0 (DA13 to DA0):** The digital value to be converted to an analog value is set in the upper 14 bits of the PWM D/A data register.

In each base cycle, the DACNT value is continually compared with these upper 14 bits to determine the duty cycle of the output waveform, and to decide whether to output a fine-adjustment pulse equal in width to the resolution. To enable this operation, the data register must be set within a range that depends on the carrier frequency select bit (CFS). If the DADR value is outside this range, the PWM output is held constant.

A channel can be operated with 12-bit precision by keeping the two lowest data bits (DA0 and DA1) cleared to 0 and writing the data to be converted in the upper 12 bits. The two lowest data bits correspond to the two highest counter (DACNT) bits.

### Bit 1—Carrier Frequency Select (CFS)

#### Bit 1

CFS	Description
0	Base cycle = resolution (T) × 64 DADR range = H'0401 to H'FFFD
1	Base cycle = resolution (T) × 256 DADR range = H'0103 to H'FFFF (Initial value)

**Bit 0—Reserved:** This bit cannot be modified and is always read as 1.

**DADR Bit 0—Register Select (REGS):** DADRA and DACR, and DADR B and DACNT, are located at the same addresses. The REGS bit specifies which registers can be accessed. The REGS bit can be accessed regardless of whether DADR B or DACNT is selected.

#### Bit 0

REGS	Description
0	DADRA and DADR B can be accessed
1	DACR and DACNT can be accessed (Initial value)

### 14.2.3 PWM D/A Control Register (DACR)

Bit	:	7	6	5	4	3	2	1	0
		TEST	PWME	—	—	OEB	OEA	OS	CKS
Initial value :		0	0	1	1	0	0	0	0
R/W	:	R/W	R/W	—	—	R/W	R/W	R/W	R/W

DACR is an 8-bit readable/writable register that selects test mode, enables the PWM outputs, and selects the output phase and operating speed.

DACR is initialized to H'30 by a reset, and in the standby modes, watch mode, subactive mode, subsleep mode, and module stop mode.

**Bit 7—Test Mode (TEST):** Selects test mode, which is used in testing the chip. Normally this bit should be cleared to 0.

**Bit 7**

TEST	Description
0	PWM (D/A) in user state: normal operation (Initial value)
1	PWM (D/A) in test state: correct conversion results unobtainable

**Bit 6—PWM Enable (PWME):** Starts or stops the PWM D/A counter (DACNT).

**Bit 6**

PWME	Description
0	DACNT operates as a 14-bit up-counter (Initial value)
1	DACNT halts at H'0003

**Bits 5 and 4—Reserved:** These bits cannot be modified and are always read as 1.

**Bit 3—Output Enable B (OEB):** Enables or disables output on PWM D/A channel B.

**Bit 3**

OEB	Description
0	PWM (D/A) channel B output (at the PWM1/PWM3 pin) is disabled (Initial value)
1	PWM (D/A) channel B output (at the PWM1/PWM3 pin) is enabled

**Bit 2—Output Enable A (OEA):** Enables or disables output on PWM D/A channel A.

**Bit 2**

OEA	Description
0	PWM (D/A) channel A output (at the PWM0/PWM2 pin) is disabled (Initial value)
1	PWM (D/A) channel A output (at the PWM0/PWM2 pin) is enabled

**Bit 1—Output Select (OS):** Selects the phase of the PWM D/A output.

**Bit 1**

OS	Description
0	Direct PWM output (Initial value)
1	Inverted PWM output

**Bit 0—Clock Select (CKS):** Selects the PWM D/A resolution. If the system clock ( $\phi$ ) frequency is 10 MHz, resolutions of 100 ns and 200 ns can be selected.

**Bit 0**

CKS	Description
0	Operates at resolution (T) = system clock cycle time ( $t_{cyc}$ ) (Initial value)
1	Operates at resolution (T) = system clock cycle time ( $t_{cyc}$ ) $\times$ 2

**14.2.4 Module Stop Control Register B (MSTPCRB)**

Bit	:	7	6	5	4	3	2	1	0
		MSTPB7	MSTPB6	MSTPB5	MSTPB4	MSTPB3	MSTPB2	MSTPB1	MSTPB0
Initial value	:	1	1	1	1	1	1	1	1
R/W	:	R/W	R/W	R/W	R/W	R/W	R/W	R/W	R/W

MSTPCRB is an 8-bit readable/writable register, and is used to perform module stop mode control.

When the MSTPB2 is set to 1, at the end of the bus cycle 14-bit PWM timer 0 operation is halted and a transition made to module stop mode. When the MSTPB1 is set to 1, at the end of the bus cycle PWM timer 1 operation is halted and a transition made to module stop mode. See section 24.5, Module Stop Mode, for details.

MSTPCRB is initialized to H'FF by a power-on reset and in hardware standby mode. It is not initialized in manual reset or software standby mode.

**Bit 2—Module Stop (MSTPB2):** Specifies PWM0 module stop mode.

**Bit 2**

MSTPB2	Description
0	PWM0 module stop mode is cleared
1	PWM0 module stop mode is set (Initial value)

**Bit 1—Module Stop (MSTPB1):** Specifies PWM1 module stop mode.

**Bit 1**

MSTPB1	Description
0	PWM1 module stop mode is cleared
1	PWM1 module stop mode is set (Initial value)

### 14.3 Bus Master Interface

DACNT, DADRA, and DADRB are 16-bit registers. The data bus linking the bus master and the on-chip supporting modules, however, is only 8 bits wide. When the bus master accesses these registers, it therefore uses an 8-bit temporary register (TEMP).

These registers are written and read as follows (taking the example of the CPU interface).

- **Write**  
When the upper byte is written, the upper-byte write data is stored in TEMP. Next, when the lower byte is written, the lower-byte write data and TEMP value are combined, and the combined 16-bit value is written in the register.
- **Read**  
When the upper byte is read, the upper-byte value is transferred to the CPU and the lower-byte value is transferred to TEMP. Next, when the lower byte is read, the lower-byte value in TEMP is transferred to the CPU.

These registers should always be accessed 16 bits at a time (by word access or two consecutive byte accesses), and the upper byte should always be accessed before the lower byte. Correct data will not be transferred if only the upper byte or only the lower byte is accessed.

Figure 14-2 shows the data flow for access to DACNT. The other registers are accessed similarly.

#### Example 1: Write to DACNT

```
MOV.W R0, @DACNT ; Write R0 contents to DACNT
```

#### Example 2: Read DADRA

```
MOV.W @DADRA, R0 ; Copy contents of DADRA to R0
```

**Table 14-3 Read and Write Access Methods for 16-Bit Registers**

Register Name	Read		Write	
	Word	Byte	Word	Byte
DADRA and DADRB	Yes	Yes	Yes	×
DACNT	Yes	×	Yes	×

Notes: Yes: Permitted type of access. Word access includes successive byte accesses to the upper byte (first) and lower byte (second).

×: This type of access may give incorrect results.

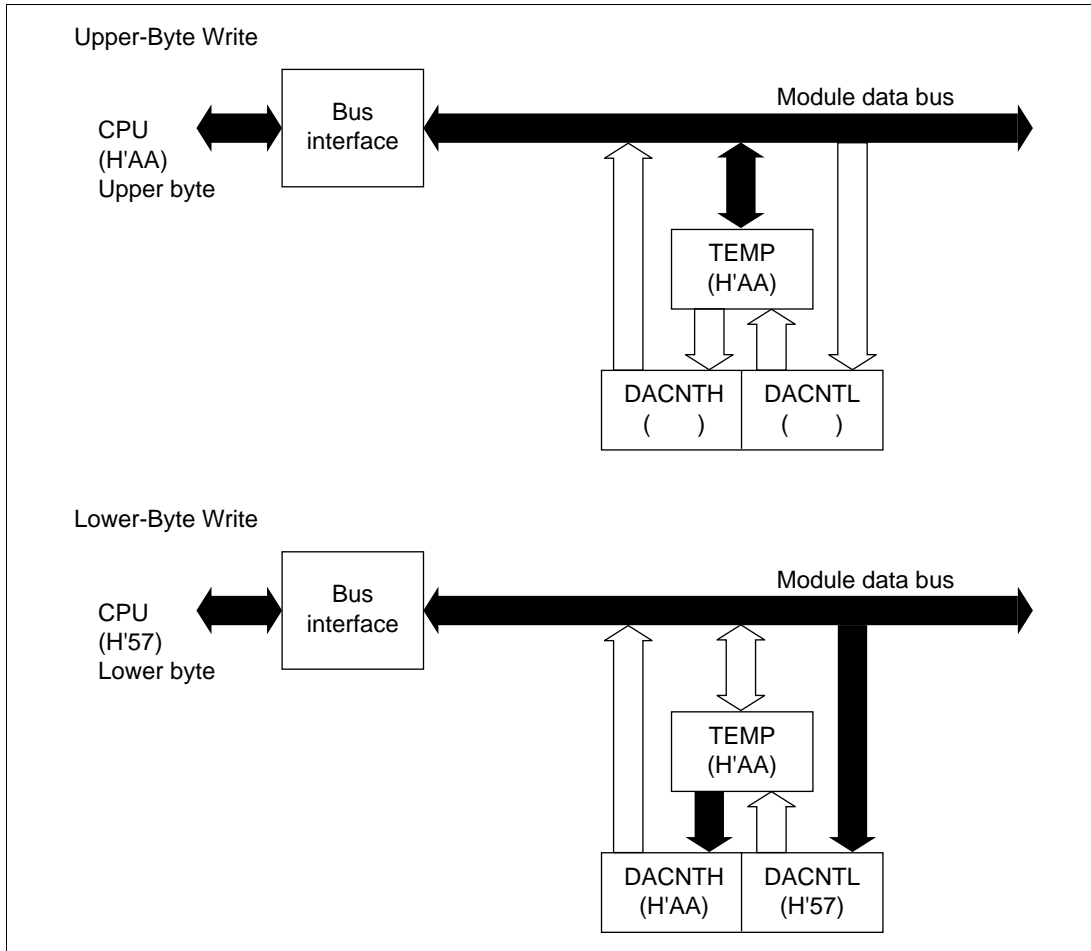


Figure 14-2 (a) Access to DACNT (CPU Writes H'AA57 to DACNT)

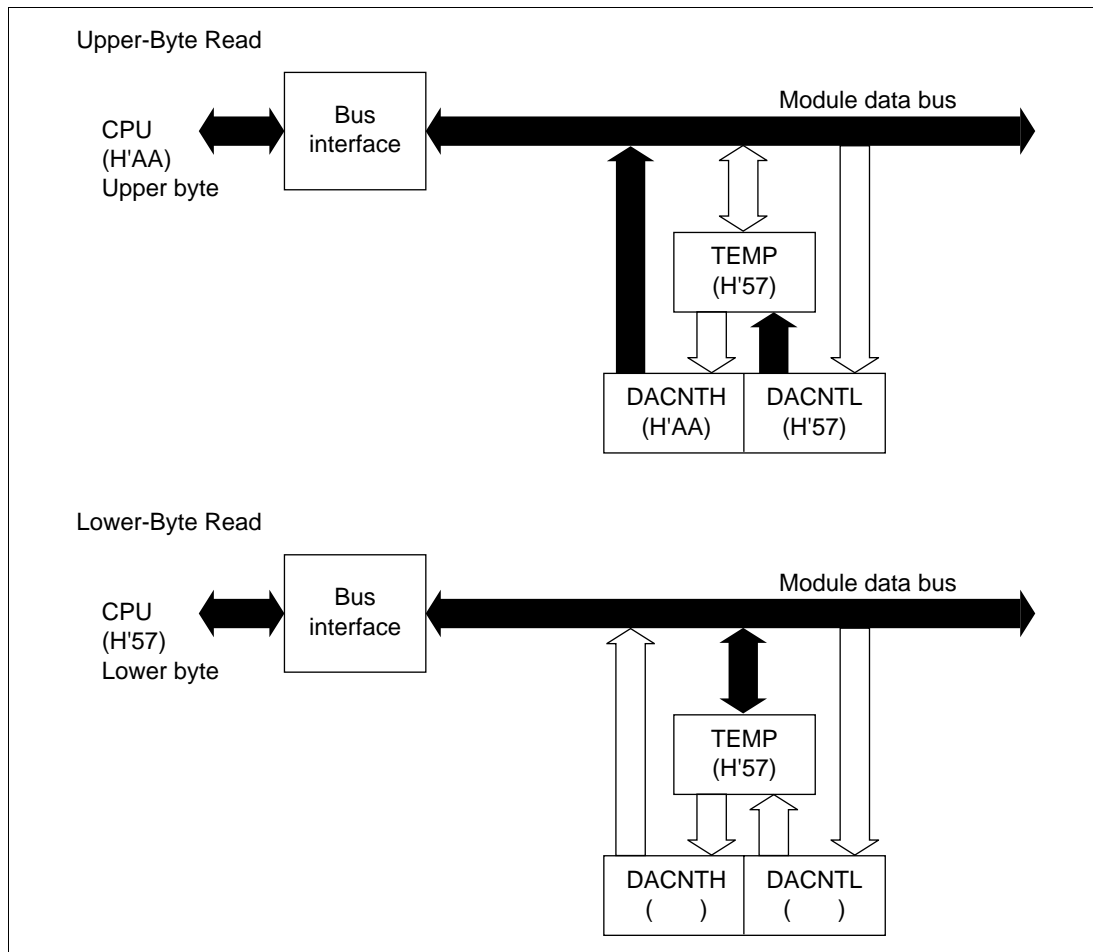
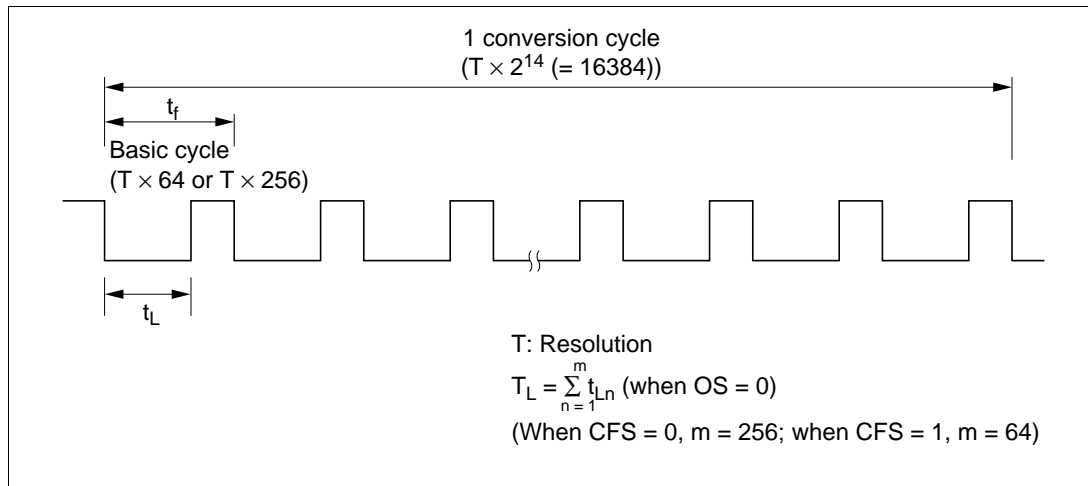


Figure 14-2 (b) Access to DACNT (CPU Reads H'AA57 from DACNT)

## 14.4 Operation

A PWM waveform like the one shown in figure 14-3 is output from the PWMX pin. When OS = 0, the value in DADR corresponds to the total width ( $T_L$ ) of the low (0) pulses output in one conversion cycle (256 pulses when CFS = 0, 64 pulses when CFS = 1). When OS = 1, the output waveform is inverted and the DADR value corresponds to the total width ( $T_H$ ) of the high (1) output pulses. Figure 14-4 shows the types of waveform output available.



**Figure 14-3 PWM D/A Operation**

Table 14-4 summarizes the relationships of the CKS, CFS, and OS bit settings to the resolution, base cycle, and conversion cycle. The PWM output remains flat unless DADR contains at least a certain minimum value. Table 14-4 indicates the range of DADR settings that give an output waveform like the one in figure 14-3, and lists the conversion cycle length when low-order DADR bits are kept cleared to 0, reducing the conversion precision to 12 bits or 10 bits.



**Table 14-4 Settings and Operation (Examples when  $\phi = 10$  MHz)**

CKS	Resolution		Base Cycle ( $\mu$ s)	Conversion Cycle ( $\mu$ s)	$T_L$ (if OS = 0) $T_H$ (if OS = 1)	Precision (Bits)	Fixed DADR Bits				Conversion Cycle* ( $\mu$ s)
	T ( $\mu$ s)	CFS					Bit Data				
							3	2	1	0	
0	0.1	0	6.4	1638.4	1. Always low (or high) (DADR = H'0001 to H'03FD)	14					1638.4
						12			0	0	409.6
						10	0	0	0	0	102.4
	1	25.6	1638.4	1. Always low (or high) (DADR = H'0003 to H'00FF)	14					1638.4	
					12			0	0	409.6	
					10	0	0	0	0	102.4	
1	0.2	0	12.8	3276.8	1. Always low (or high) (DADR = H'0001 to H'03FD)	14					3276.8
						12			0	0	819.2
						10	0	0	0	0	204.8
	1	51.2	3276.8	1. Always low (or high) (DADR = H'0003 to H'00FF)	14					3276.8	
					12			0	0	819.2	
					10	0	0	0	0	204.8	

Note: \* This column indicates the conversion cycle when specific DADR bits are fixed.

1. OS = 0 (DADR corresponds to  $T_1$ )

a. CFS = 0 [base cycle = resolution (T) × 64]

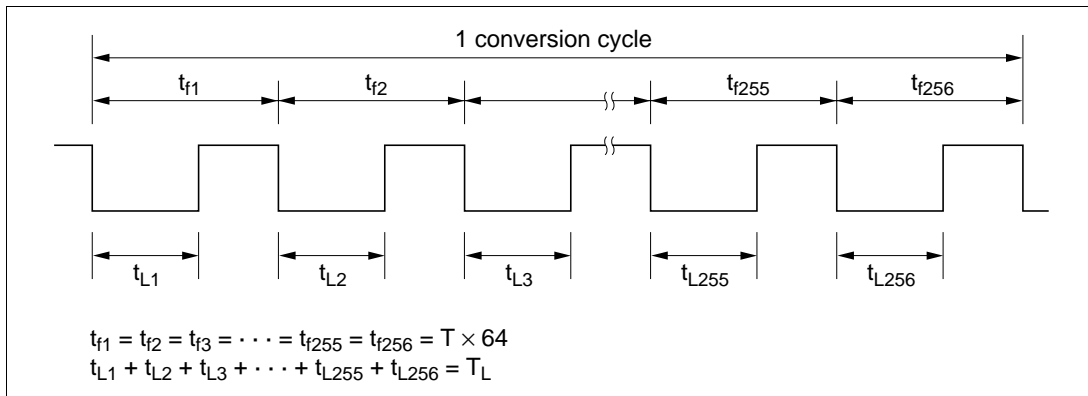


Figure 14-4 (1) Output Waveform

b. CFS = 1 [base cycle = resolution (T) × 256]

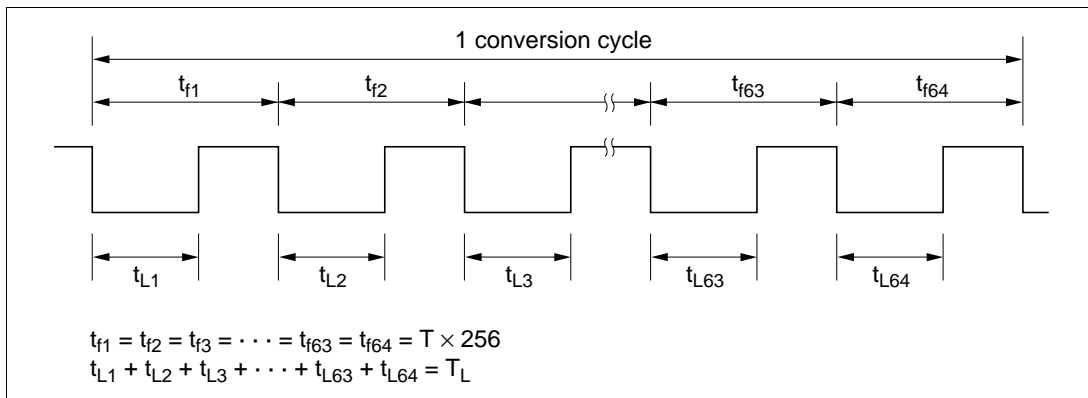
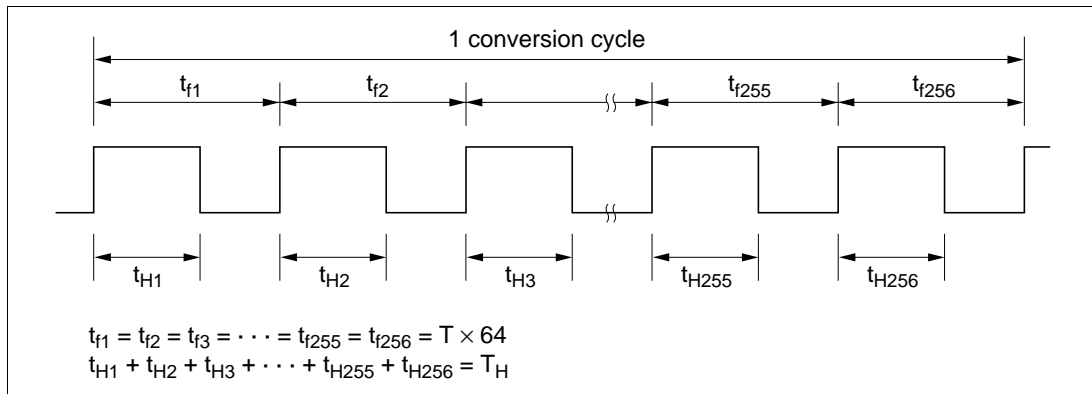


Figure 14-4 (2) Output Waveform

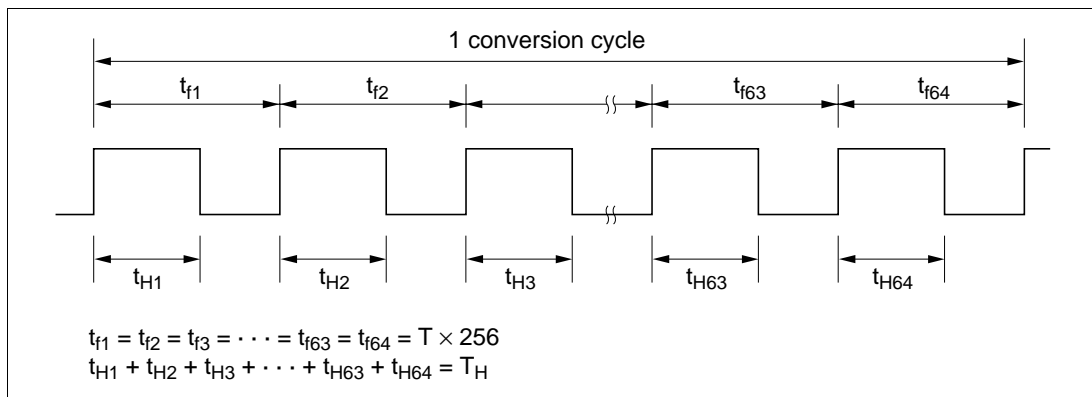
2. OS = 1 (DADR corresponds to  $T_H$ )

a. CFS = 0 [base cycle = resolution (T) × 64]



**Figure 14-4 (3) Output Waveform**

b. CFS = 1 [base cycle = resolution (T) × 256]



**Figure 14-4 (4) Output Waveform**



## Section 15 Watchdog Timer

(WDT1 is not available in the H8S/2695)

### 15.1 Overview

The H8S/2633 Series has a two channel inbuilt watchdog timer, (WDT0/WDT1). The WDT outputs an overflow signal ( $\overline{\text{WDTOVF}}$ ) if a system crash prevents the CPU from writing to the timer counter, allowing it to overflow. At the same time, the WDT can also generate an internal reset signal for the H8S/2633 Series.

When this watchdog function is not needed, the WDT can be used as an interval timer. In interval timer operation, an interval timer interrupt is generated each time the counter overflows.

#### 15.1.1 Features

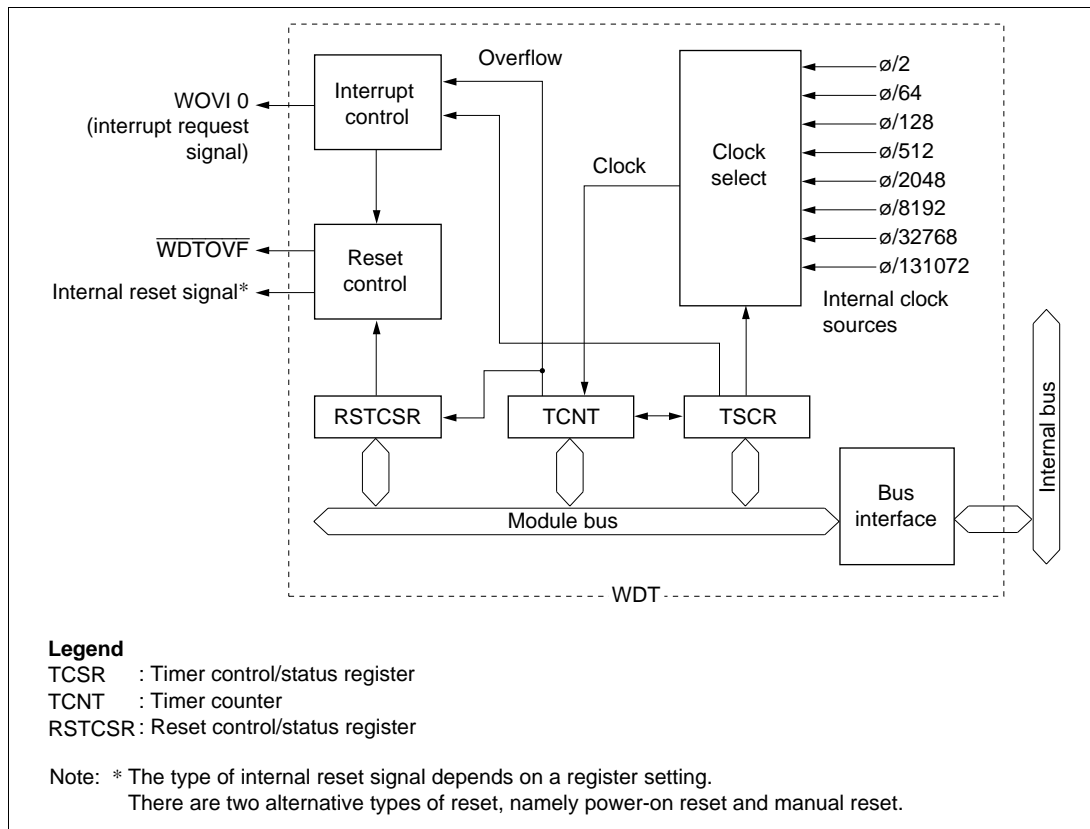
WDT features are listed below.

- Switchable between watchdog timer mode and interval timer mode
- $\overline{\text{WDTOVF}}$  output when in watchdog timer mode  
If the counter overflows, the WDT outputs  $\overline{\text{WDTOVF}}$ . It is possible to select whether the LSI is internally reset or an NMI interrupt is generated at the same time.  
This internal reset is effected by either a power-on reset or a manual reset.
- Interrupt generation when in interval timer mode  
If the counter overflows, the WDT generates an interval timer interrupt.
- WDT0 and WDT1 respectively allow eight and sixteen types of counter input clock to be selected  
The maximum interval of the WDT is given as a system clock cycle  $\times 131072 \times 256$ .  
A subclock may be selected for the input counter of WDT1\*.  
Where a subclock is selected, the maximum interval is given as a subclock cycle  $\times 256 \times 256$ .
- Selected clock can be output from the BUZZ\* output pin (WDT1)\*

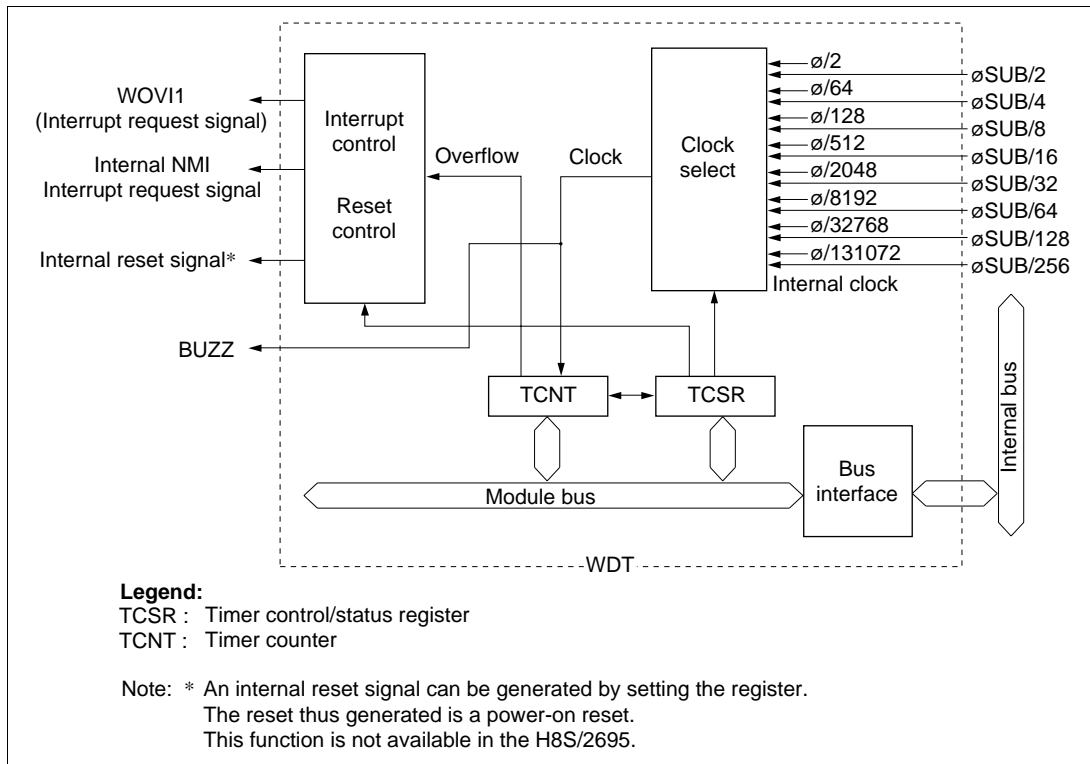
Note: \* This function is not available in the H8S/2695.

### 15.1.2 Block Diagram

Figure 15-1 (a) and 15-1 (b) show a block diagram of the WDT.



**Figure 15-1 (a) Block Diagram of WDT0**



**Figure 15-1 (b) Block Diagram of WDT1**

### 15.1.3 Pin Configuration

Table 15-1 describes the WDT output pin.

**Table 15-1 WDT Pin**

Name	Symbol	I/O	Function
Watchdog timer overflow	WDTOVF	Output	Outputs counter overflow signal in watchdog timer mode
Buzzer output	BUZZ*	Output	Outputs clock selected by watchdog timer (WDT1)

Note: \* This function is not available in the H8S/2695.

### 15.1.4 Register Configuration

Table 15-2 summarizes the WDT register configuration. These registers control clock selection, WDT mode switching, and the reset signal.

**Table 15-2 WDT Registers**

Channel Name	Abbreviation	R/W	Initial Value	Address* <sup>1</sup>		
				Write* <sup>2</sup>	Read	
0	Timer control/status register 0	TCSR0	R/(W)* <sup>3</sup>	H'18	H'FF74	H'FF74
	Timer counter 0	TCNT0	R/W	H'00	H'FF74	H'FF75
	Reset control/status register	RSTCSR	R/(W)* <sup>3</sup>	H'1F	H'FF76	H'FF77
1	Timer control/status register 1	TCSR1	R/(W)* <sup>3</sup>	H'00	H'FFA2	H'FFA2
	Timer counter 1	TCNT1	R/W	H'00	H'FFA2	H'FFA3
All	Pin function control register	PFCR	R/W	H'0D/H'00	H'FDEB	

Notes: \*<sup>1</sup> Lower 16 bits of the address.

\*<sup>2</sup> For details of write operations, see section 15.2.5, Notes on Register Access.

\*<sup>3</sup> Only a write of 0 is permitted to bit 7, to clear the flag.



## 15.2 Register Descriptions

### 15.2.1 Timer Counter (TCNT)

Bit	:	7	6	5	4	3	2	1	0
Initial value :		0	0	0	0	0	0	0	0
R/W	:	R/W	R/W	R/W	R/W	R/W	R/W	R/W	R/W

TCNT is an 8-bit readable/writable\* up-counter.

When the TME bit is set to 1 in TCSR, TCNT starts counting pulses generated from the internal clock source selected by bits CKS2 to CKS0 in TCSR. When the count overflows (changes from H'FF to H'00), either the watchdog timer overflow signal ( $\overline{\text{WDTOVF}}$ ) or an interval timer interrupt (WOVI) is generated, depending on the mode selected by the WT/ $\overline{\text{IT}}$  bit in TCSR.

TCNT is initialized to H'00 by a reset, in hardware standby mode, or when the TME bit is cleared to 0. It is not initialized in software standby mode.

Note: \* TCNT is write-protected by a password to prevent accidental overwriting. For details see section 15.2.5, Notes on Register Access.

### 15.2.2 Timer Control/Status Register (TCSR)

#### TCSR0

Bit	:	7	6	5	4	3	2	1	0
		OVF	WT/ $\overline{\text{IT}}$	TME	—	—	CKS2	CKS1	CKS0
Initial value :		0	0	0	1	1	0	0	0
R/W	:	R/(W)*	R/W	R/W	—	—	R/W	R/W	R/W

Note: \* Only a 0 can be written, for flag clearing.

#### TCSR1\*<sup>1</sup>

Bit	:	7	6	5	4	3	2	1	0
		OVF	WT/ $\overline{\text{IT}}$	TME	PSS	RST/NMI	CKS2	CKS1	CKS0
Initial value :		0	0	0	0	0	0	0	0
R/W	:	R/(W)* <sup>2</sup>	R/W	R/W	R/W	R/W	R/W	R/W	R/W

Notes: \*<sup>1</sup> In the case of the H8S/2695, only 0 should be written to the TCSR1 register.

\*<sup>2</sup> Only a 0 can be written, for flag clearing.

TCSR is an 8-bit readable/writable\* register. Its functions include selecting the clock source to be input to TCNT, and the timer mode.

TCSR0 (TCSR1) is initialized to H'18 (H'00) by a reset and in hardware standby mode. It is not initialized in software standby mode.

Note: \* TCSR is write-protected by a password to prevent accidental overwriting. For details see section 15.2.5, Notes on Register Access.

**Bit 7—Overflow Flag (OVF):** Indicates that TCNT has overflowed from H'FF to H'00.

Bit 7 OVF	Description
0	[Clearing conditions] (Initial value) <ul style="list-style-type: none"> <li>• Cleared when 0 is written to the TME bit (Only applies to WDT1)</li> <li>• Cleared by reading TCSR when OVF = 1, then writing 0 to OVF</li> </ul>
1	[Setting condition] <p>When TCNT overflows (changes from H'FF to H'00) When internal reset request generation is selected in watchdog timer mode, OVF is cleared automatically by the internal reset.</p>

In interval timer mode, to clear OVF flag in WOVI handling routine, read TCSR when OVF = 1, then write with 0 to OVF, as stated above.

When WOVI is masked and OVF flag is poling, if contention between OVF flag set and TCSR read is occurred, OVF = 1 is read but OVF can not be cleared by writing with 0 to OVF.

In this case, reading TCSR when OVF = 1 two times meet the requirements of OVF clear condition. Please read TCSR when OVF = 1 two times before writing with 0 to OVF.

**Bit 6—Timer Mode Select (WT/IT):** Selects whether the WDT is used as a watchdog timer or interval timer. When TCNT overflows, WDT0 generates the  $\overline{\text{WDT0VF}}$  signal when in watchdog timer mode, or a WOVI interrupt request to the CPU when in interval timer mode. WDT1\* generates a reset or NMI interrupt request when in watchdog timer mode, or a WOVI interrupt request to the CPU when in interval timer mode.

Note: \* This function is not available in the H8S/2695.

#### WDT0 Mode Select

WDT0 WT/IT	Description
0	Interval timer mode: WDT0 requests an interval timer interrupt (WOVI) from the CPU when the TCNT overflows. (Initial value)
1	Watchdog timer mode: WDT0 outputs a $\overline{\text{WDT0VF}}$ signal when the TCNT overflows.*

Note: \* For details on a TCNT overflow in watchdog timer mode, see section 15.2.3, Reset Control/Status Register (RSTCSR).

### WDT1\* Mode Select

WDT1 WT/IT	Description
0	Interval timer mode: WDT1 requests an interval timer interrupt (WOVI) from the CPU when the TCNT overflows. (Initial value)
1	Watchdog timer mode: WDT1 requests a reset or an NMI interrupt from the CPU when the TCNT overflows.

Note: \* In the case of the H8S/2695, only 0 should be written to the WT/IT bit in the TCSR1 register.

**Bit 5—Timer Enable (TME):** Selects whether TCNT runs or is halted.

Bit 5 TME	Description
0	TCNT is initialized to H'00 and halted (Initial value)
1	TCNT counts

**WDT0 TCSR Bit 4—Reserved Bit:** This bit is always read as 1 and cannot be modified.

Note: In the case of the H8S/2695, only 0 should be written to the TME bit in the TCSR1 register.

**WDT1 TCSR Bit 4—Prescaler Select (PSS):** This bit is used to select an input clock source for the TCNT of WDT1.

See the descriptions of Clock Select 2 to 0 for details.

WDT1 TCSR Bit 4 PSS	Description
0	The TCNT counts frequency-division clock pulses of the $\phi$ based prescaler (PSM). (Initial value)
1	The TCNT counts frequency-division clock pulses of the $\phi$ SUB-based prescaler (PSS).

Note: In the case of the H8S/2695, only 0 should be written to the PSS bit in the TCSR1 register.

**WDT0 TCSR Bit 3—Reserved Bit:** This bit is always read as 1 and cannot be modified.

**WDT1 TCSR Bit 3—Reset or NMI (RST/ $\overline{\text{NMI}}$ ):** This bit is used to choose between an internal reset request and an NMI request when the TCNT overflows during the watchdog timer mode.

**Bit 3**

<b>RTS/<math>\overline{\text{NMI}}</math></b>	<b>Description</b>	
0	NMI request.	(Initial value)
1	Internal reset request.	

**Bits 2 to 0: Clock Select 2 to 0 (CKS2 to CKS0):** These bits select one of eight internal clock sources, obtained by dividing the system clock ( $\phi$ ) or subclock ( $\phi$  SUB), for input to TCNT.

Note: In the case of the H8S/2695, only 0 should be written to the RST/ $\overline{\text{NMI}}$  bit in the TCSR1 register.

**WDT0 Input Clock Select**

<b>Bit 2 CKS2</b>	<b>Bit 1 CKS1</b>	<b>Bit 0 CKS0</b>	<b>Description</b>	
			<b>Clock</b>	<b>Overflow Period* (where <math>\phi = 25</math> MHz)</b>
0	0	0	$\phi/2$ (Initial value)	20.4 $\mu$ s
		1	$\phi/64$	655.3 $\mu$ s
	1	0	$\phi/128$	1.3 ms
		1	$\phi/512$	5.2 ms
1	0	0	$\phi/2048$	20.9 ms
		1	$\phi/8192$	83.8 ms
	1	0	$\phi/32768$	335.5 ms
		1	$\phi/131072$	1.34 s

Note: \* An overflow period is the time interval between the start of counting up from H'00 on the TCNT and the occurrence of a TCNT overflow.

### WDT1\*1 Input Clock Select

Bit 4 PSS	Bit 2 CKS2	Bit 1 CKS1	Bit 0 CKS0	Description	
				Clock	Overflow Period*2 (where $\phi = 25$ MHz) (where $\phi$ SUB = 32.768 kHz)
0	0	0	0	$\phi/2$ (Initial value)	20.4 $\mu$ s
			1	$\phi/64$	655.3 $\mu$ s
		1	0	$\phi/128$	1.3 ms
			1	$\phi/512$	5.2 ms
	1	0	0	$\phi/2048$	20.9 ms
			1	$\phi/8192$	83.8 ms
		1	0	$\phi/32768$	335.5 ms
			1	$\phi/131072$	1.34 s
1	0	0	0	$\phi$ SUB/2	15.6 ms
			1	$\phi$ SUB/4	31.3 ms
		1	0	$\phi$ SUB/8	62.5 ms
			1	$\phi$ SUB/16	125 ms
	1	0	0	$\phi$ SUB/32	250 ms
			1	$\phi$ SUB/64	500 ms
		1	0	$\phi$ SUB/128	1 s
			1	$\phi$ SUB/256	2 s

Notes: \*1 WDT1 is not available in the H8S/2695.

\*2 An overflow period is the time interval between the start of counting up from H'00 on the TCNT and the occurrence of a TCNT overflow.

### 15.2.3 Reset Control/Status Register (RSTCSR)

Bit	:	7	6	5	4	3	2	1	0
		WOVF	RSTE	RSTS	—	—	—	—	—
Initial value :		0	0	0	1	1	1	1	1
R/W	:	R/(W)*	R/W	R/W	—	—	—	—	—

Note: \* Only 0 can be written, for flag clearing.

RSTCSR is an 8-bit readable/writable\* register that controls the generation of the internal reset signal when TCNT overflows, and selects the type of internal reset signal.

RSTCSR is initialized to H'1F by a reset signal from the  $\overline{\text{RES}}$  pin, but not by the WDT internal reset signal caused by overflows.

Note: \* RSTCSR is write-protected by a password to prevent accidental overwriting. For details see section 15.2.5, Notes on Register Access.

**Bit 7—Watchdog Overflow Flag (WOVF):** Indicates that TCNT has overflowed (changed from H'FF to H'00) during watchdog timer operation. This bit is not set in interval timer mode.

#### Bit 7

WOVF	Description
0	[Clearing condition] (Initial value) Cleared by reading RSTCSR when WOVF = 1, then writing 0 to WOVF
1	[Setting condition] Set when TCNT overflows (changed from H'FF to H'00) during watchdog timer operation

**Bit 6—Reset Enable (RSTE):** Specifies whether or not a reset signal is generated in the H8S/2633 Series if TCNT overflows during watchdog timer operation.

#### Bit 6

RSTE	Description
0	Reset signal is not generated if TCNT overflows* (Initial value)
1	Reset signal is generated if TCNT overflows

Note: \* The modules within the H8S/2633 Series are not reset, but TCNT and TCSR within the WDT are reset.

**Bit 5—Reset Select (RSTS):** Selects the type of internal reset generated if TCNT overflows during watchdog timer operation.

For details of the types of reset, see section 4, Exception Handling.

Bit 5	
RSTS	Description
0	Power-on reset (Initial value)
1	Manual reset

**Bits 4 to 0—Reserved:** These bits are always read as 1 and cannot be modified.

#### 15.2.4 Pin Function Control Register (PFCR)

Bit	:	7	6	5	4	3	2	1	0
		CSS07	CSS36	BUZZE*	LCASS	AE3	AE2	AE1	AE0
Initial value	:	0	0	0	0	1/0	1/0	0	1/0
R/W	:	R/W	R/W	R/W	R/W	R/W	R/W	R/W	R/W

Note: \* This function is not available in the H8S/2695.

PFCR is an 8-bit readable/writable register that performs address output control in external expanded mode.

Only bit 5 is described here. For details of the other bits, see section 7.2.6, Pin Function Control Register (PFCR).

**Bit 5—BUZZ Output Enable (BUZZE):** Enables or disables BUZZ output from the PF1 pin. The WDT1 input clock selected with bits PSS and CKS2 to CKS0 is output as the BUZZ signal.

Bit 5	
BUZZE	Description
0	Functions as PF1 I/O pin (Initial value)
1	Functions as BUZZ output pin

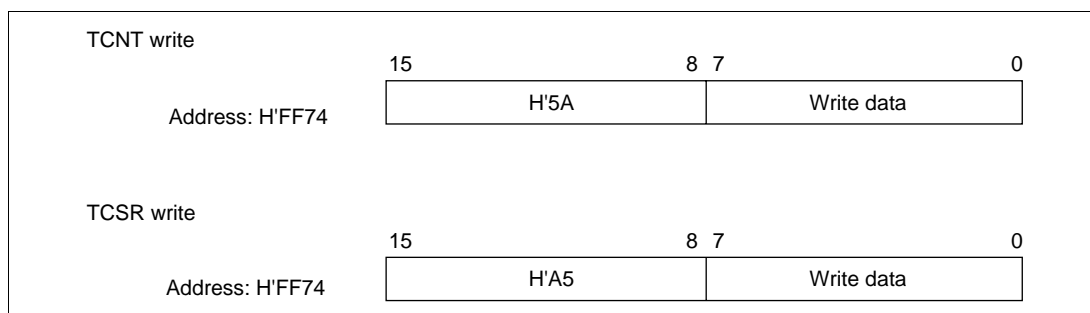
Note: In the case of the H8S/2695, only 0 should be written to the BUZZ bit.

### 15.2.5 Notes on Register Access

The watchdog timer's TCNT, TCSR, and RSTCSR registers differ from other registers in being more difficult to write to. The procedures for writing to and reading these registers are given below.

**Writing to TCNT and TCSR:** These registers must be written to by a word transfer instruction. They cannot be written to with byte instructions.

Figure 15-2 shows the format of data written to TCNT and TCSR. TCNT and TCSR both have the same write address. For a write to TCNT, the upper byte of the written word must contain H'5A and the lower byte must contain the write data. For a write to TCSR, the upper byte of the written word must contain H'A5 and the lower byte must contain the write data. This transfers the write data from the lower byte to TCNT or TCSR.



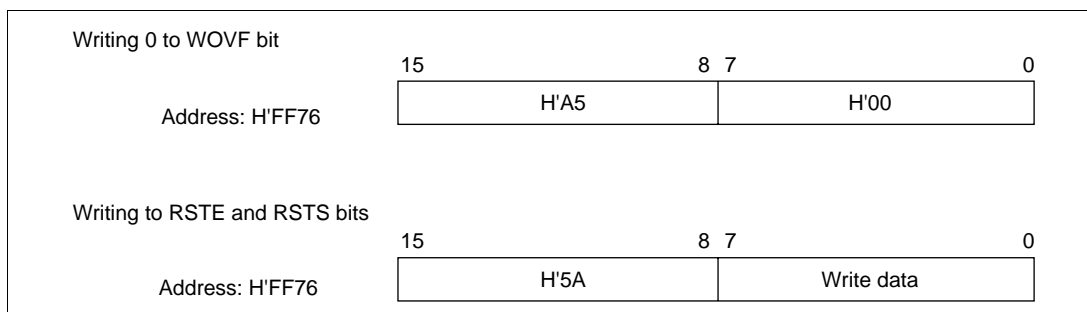
**Figure 15-2 Format of Data Written to TCNT and TCSR (WDT0)**



**Writing to RSTCSR:** RSTCSR must be written to by word transfer instruction to address H'FF76. It cannot be written to with byte instructions.

Figure 15-3 shows the format of data written to RSTCSR. The method of writing 0 to the WOVF bit differs from that for writing to the RSTE and RSTS bits.

To write 0 to the WOVF bit, the write data must have H'A5 in the upper byte and H'00 in the lower byte. This clears the WOVF bit to 0, but has no effect on the RSTE and RSTS bits. To write to the RSTE and RSTS bits, the upper byte must contain H'5A and the lower byte must contain the write data. This writes the values in bits 6 and 5 of the lower byte into the RSTE and RSTS bits, but has no effect on the WOVF bit.



**Figure 15-3 Format of Data Written to RSTCSR (WDT0)**

**Reading TCNT, TCSR, and RSTCSR (WDT0):** These registers are read in the same way as other registers. The read addresses are H'FF74 for TCSR, H'FF75 for TCNT, and H'FF77 for RSTCSR.

## 15.3 Operation

### 15.3.1 Watchdog Timer Operation

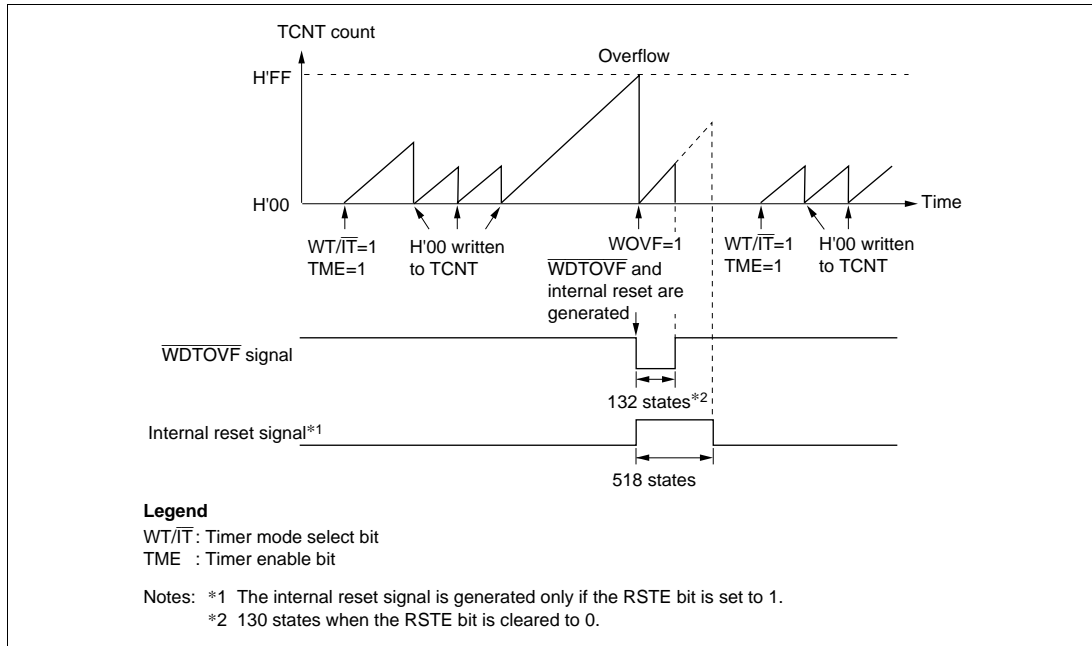
To use the WDT as a watchdog timer, set the  $\overline{WT/IT}$  bit in TCSR and TME bit to 1. Software must prevent TCNT overflows by rewriting the TCNT value (normally by writing H'00) before overflows occurs. This ensures that TCNT does not overflow while the system is operating normally. If TCNT overflows without being rewritten because of a system crash or other error, in the WDT0 the  $\overline{WDTOVF}$  signal is output. This is shown in figure 15-4 (a). This  $\overline{WDTOVF}$  signal can be used to reset the system. The  $\overline{WDTOVF}$  signal is output for 132 states when RSTE = 1, and for 130 states when RSTE = 0.

If TCNT overflows when 1 is set in the RSTE bit in RSTCSR, a signal that resets the H8S/2633 Series internally is generated at the same time as the  $\overline{WDTOVF}$  signal. This reset can be selected as a power-on reset or a manual reset, depending on the setting of the RSTS bit in RSTCSR. The internal reset signal is output for 518 states.

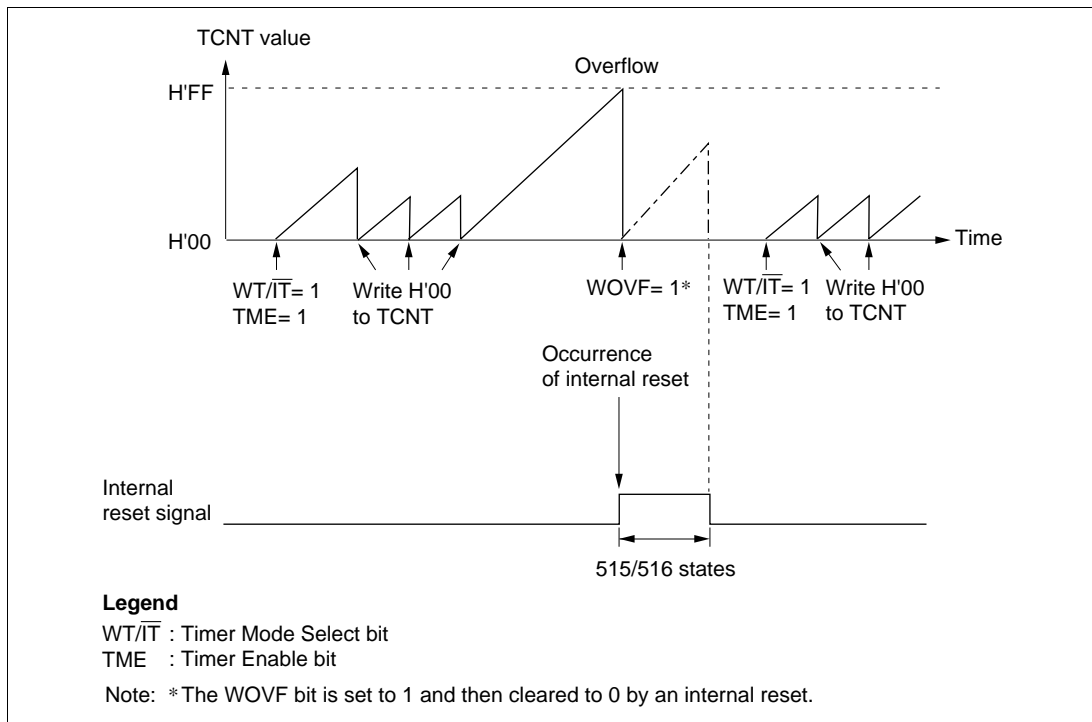
If a reset caused by a signal input to the  $\overline{RES}$  pin occurs at the same time as a reset caused by a WDT overflow, the  $\overline{RES}$  pin reset has priority and the WOVF bit in RSTCSR is cleared to 0.

In the case of WDT1, the chip is reset, or an NMI interrupt request is generated, for 516 system clock periods (516 $\phi$ ) (515 or 516 states when the clock source is  $\phi$ SUB (PSS = 1)). This is illustrated in figure 15-4 (b).

An NMI request from the watchdog timer and an interrupt request from the NMI pin are both treated as having the same vector. So, avoid handling an NMI request from the watchdog timer and an interrupt request from the NMI pin at the same time.



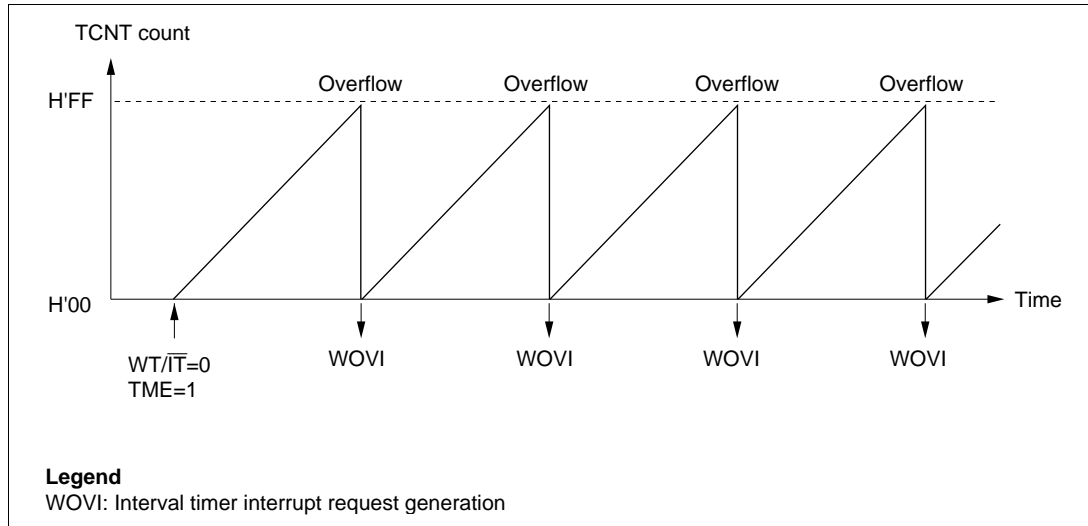
**Figure 15-4 (a) WDT0 Watchdog Timer Operation**



**Figure 15-4 (b) WDT1 Operation in Watchdog Timer Mode**

### 15.3.2 Interval Timer Operation

To use the WDT as an interval timer, clear the  $WT/\overline{IT}$  bit in TCSR to 0 and set the TME bit to 1. An interval timer interrupt (WOVI) is generated each time TCNT overflows, provided that the WDT is operating as an interval timer, as shown in figure 15-5. This function can be used to generate interrupt requests at regular intervals.



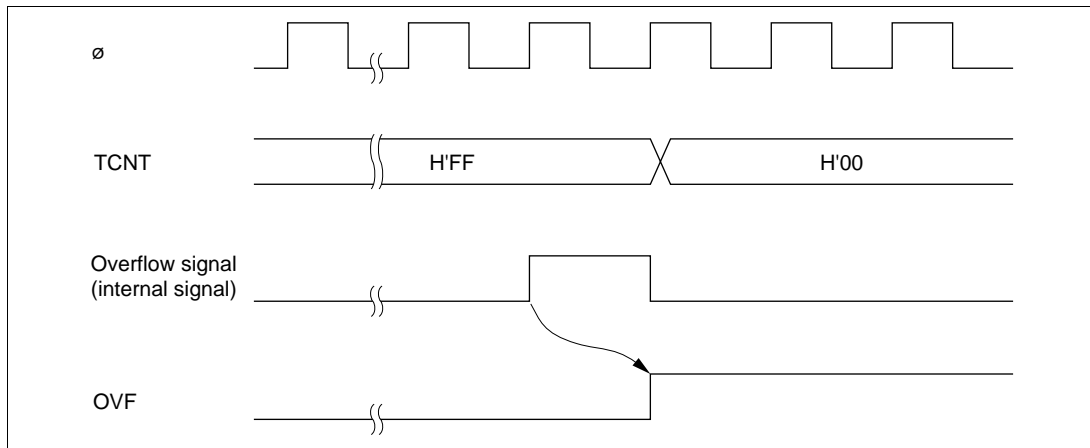
**Figure 15-5 Interval Timer Operation**

### 15.3.3 Timing of Setting Overflow Flag (OVF)

The OVF flag is set to 1 if TCNT overflows during interval timer operation. At the same time, an interval timer interrupt (WOVI) is requested. This timing is shown in figure 15-6.

With WDT1\*, the OVF bit of the TCSR is set to 1 and a simultaneous NMI interrupt is requested when the TCNT overflows if the NMI request has been chosen in the watchdog timer mode.

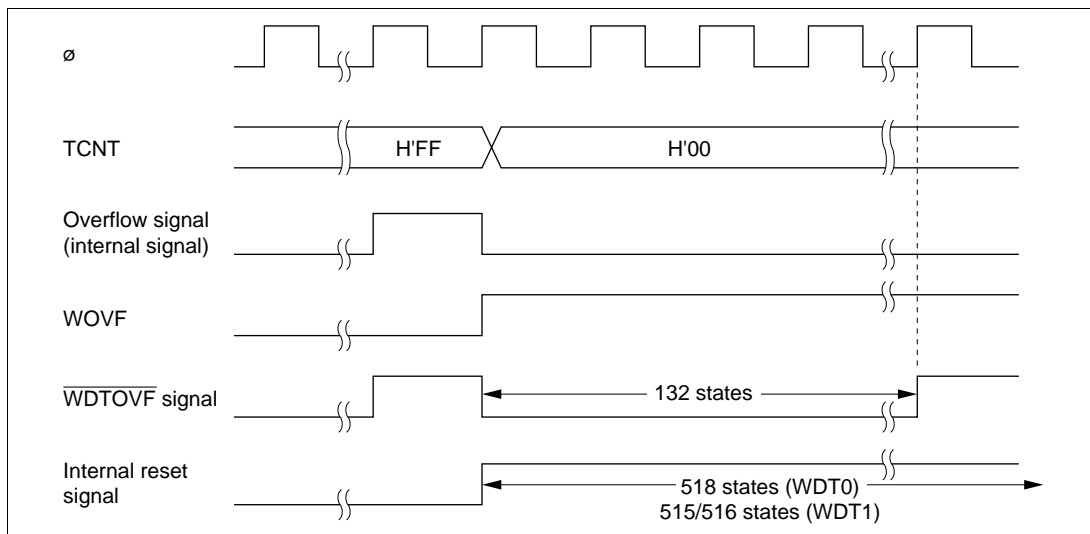
Note: \* WDT1 is not available in the H8S/2695.



**Figure 15-6 Timing of Setting of OVF**

### 15.3.4 Timing of Setting of Watchdog Timer Overflow Flag (WOVF)

In the WDT0, the WOVF flag is set to 1 if TCNT overflows during watchdog timer operation. At the same time, the WDTOVF signal goes low. If TCNT overflows while the RSTE bit in RSTCSR is set to 1, an internal reset signal is generated for the entire H8S/2633 Series chip. Figure 15-7 shows the timing in this case.



**Figure 15-7 Timing of Setting of WOVF**

## 15.4 Interrupts

During interval timer mode operation, an overflow generates an interval timer interrupt (WOVI). The interval timer interrupt is requested whenever the OVF flag is set to 1 in TCSR. OVF must be cleared to 0 in the interrupt handling routine.

If an NMI request has been chosen in the watchdog timer mode, an NMI request is generated when a TCNT overflow occurs.

## 15.5 Usage Notes

### 15.5.1 Contention between Timer Counter (TCNT) Write and Increment

If a timer counter clock pulse is generated during the  $T_2$  state of a TCNT write cycle, the write takes priority and the timer counter is not incremented. Figure 15-8 shows this operation.

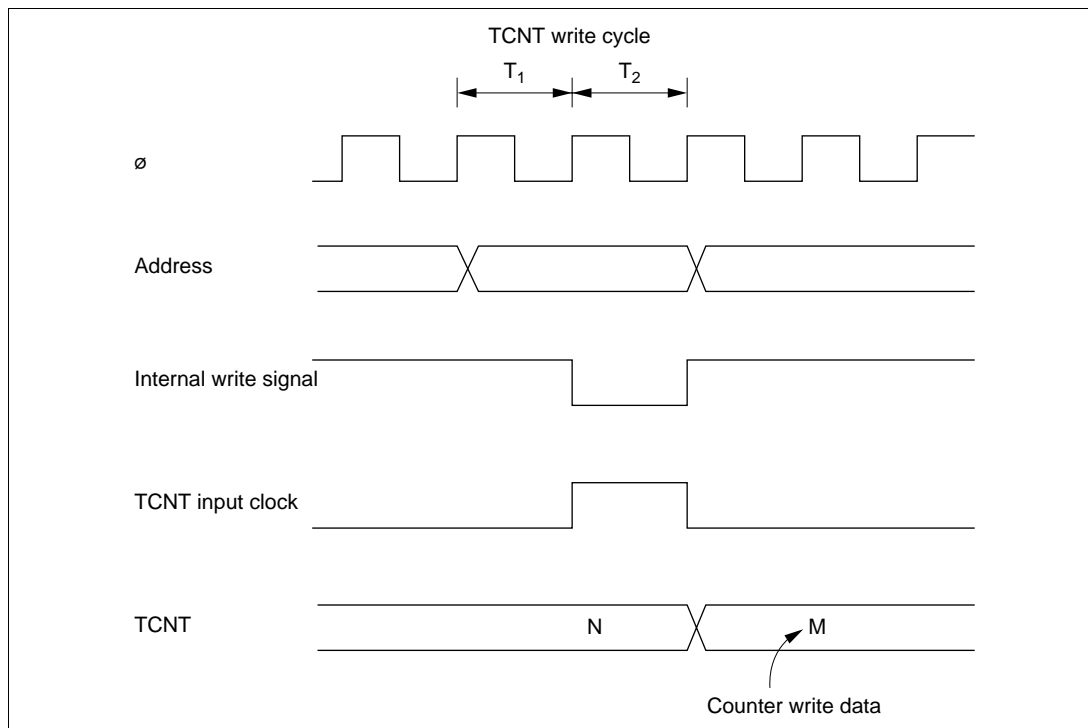


Figure 15-8 Contention between TCNT Write and Increment

### 15.5.2 Changing Value of PSS and CKS2 to CKS0

If bits PSS and CKS2 to CKS0 in TCSR are written to while the WDT is operating, errors could occur in the incrementation. Software must stop the watchdog timer (by clearing the TME bit to 0) before changing the value of bits PSS and CKS2 to CKS0.

### 15.5.3 Switching between Watchdog Timer Mode and Interval Timer Mode

If the mode is switched from watchdog timer to interval timer, or vice versa, while the WDT is operating, errors could occur in the incrementation. Software must stop the watchdog timer (by clearing the TME bit to 0) before switching the mode.

### 15.5.4 System Reset by $\overline{\text{WDTOVF}}$ Signal

If the  $\overline{\text{WDTOVF}}$  output signal is input to the  $\overline{\text{RES}}$  pin of the H8S/2633 Series, the H8S/2633 Series will not be initialized correctly. Make sure that the  $\overline{\text{WDTOVF}}$  signal is not input logically to the  $\overline{\text{RES}}$  pin. To reset the entire system by means of the  $\overline{\text{WDTOVF}}$  signal, use the circuit shown in figure 15-9.

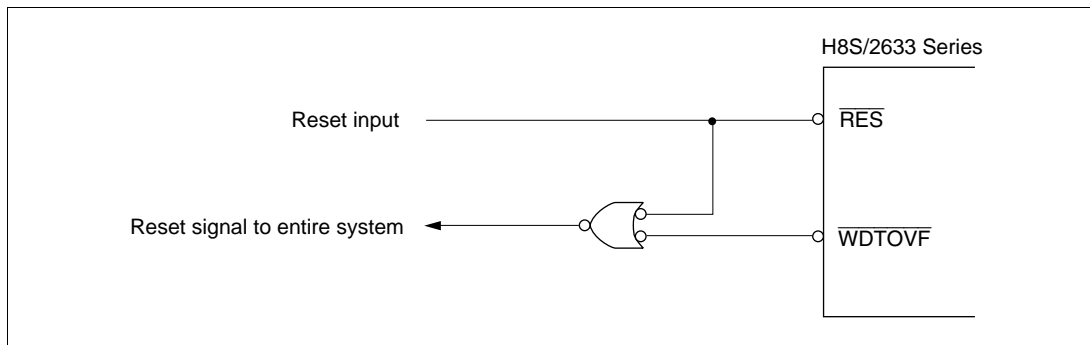


Figure 15-9 Circuit for System Reset by  $\overline{\text{WDTOVF}}$  Signal (Example)

### 15.5.5 Internal Reset in Watchdog Timer Mode

The H8S/2633 Series is not reset internally if TCNT overflows while the RSTE bit is cleared to 0 during watchdog timer operation, but TCNT and TCSR of the WDT are reset.

TCNT, TCSR, and RSTCSR cannot be written to while the  $\overline{\text{WDTOVF}}$  signal is low. Also note that a read of the WOVF flag is not recognized during this period. To clear the WOVF flag, therefore, read RSTCSR after the  $\overline{\text{WDTOVF}}$  signal goes high, then write 0 to the WOVF flag.

### **15.5.6 OVF Flag Clearing in Interval Timer Mode**

When the OVF Flag setting conflicts with the OVF flag reading in interval timer mode, writing 0 to the OVF bit may not clear the flag even though the OVF bit has been read while it is 1. If there is a possibility that the OVF flag setting and reading will conflict, such as when the OVF flag is polled with the interval timer interrupt disabled, read the OVF bit while it is 1 at least twice before writing 0 to the OVF bit to clear the flag.



## Section 16 Serial Communication Interface (SCI, IrDA)

(The H8S/2695 is not equipped with an IrDA function)

### 16.1 Overview

The H8S/2633 is equipped with 5 independent serial communication interface (SCI) channels. The SCI can handle both asynchronous and clocked synchronous serial communication. A function is also provided for serial communication between processors (multiprocessor communication function).

One of the five SCI channels is capable of sending and receiving IrDA communications waveforms (based on IrDA Version 1.0).

#### 16.1.1 Features

SCI features are listed below.

- Choice of asynchronous or clocked synchronous serial communication mode

##### Asynchronous mode

— Serial data communication executed using asynchronous system in which synchronization is achieved character by character

Serial data communication can be carried out with standard asynchronous communication chips such as a Universal Asynchronous Receiver/Transmitter (UART) or Asynchronous Communication Interface Adapter (ACIA)

— A multiprocessor communication function is provided that enables serial data communication with a number of processors

— Choice of 12 serial data transfer formats

Data length : 7 or 8 bits

Stop bit length : 1 or 2 bits

Parity : Even, odd, or none

Multiprocessor bit : 1 or 0

— Receive error detection : Parity, overrun, and framing errors

— Break detection : Break can be detected by reading the RxD pin level directly in case of a framing error

##### Clocked Synchronous mode

— Serial data communication synchronized with a clock

Serial data communication can be carried out with other chips that have a synchronous communication function

- One serial data transfer format
  - Data length : 8 bits
- Receive error detection : Overrun errors detected
- Full-duplex communication capability
  - The transmitter and receiver are mutually independent, enabling transmission and reception to be executed simultaneously
  - Double-buffering is used in both the transmitter and the receiver, enabling continuous transmission and continuous reception of serial data
- Choice of LSB-first or MSB-first transfer
  - Can be selected regardless of the communication mode\* (except in the case of asynchronous mode 7-bit data)

Note: \* Descriptions in this section refer to LSB-first transfer.

- On-chip baud rate generator allows any bit rate to be selected
- Choice of serial clock source: internal clock from baud rate generator or external clock from SCK pin
- Four interrupt sources
  - Four interrupt sources — transmit-data-empty, transmit-end, receive-data-full, and receive error — that can issue requests independently
  - The transmit-data-empty interrupt and receive data full interrupts can activate the DMA controller (DMAC) or data transfer controller (DTC) to execute data transfer
- Module stop mode can be set
  - As the initial setting, SCI operation is halted. Register access is enabled by exiting module stop mode

## 16.1.2 Block Diagram

Figure 16-1 shows a block diagram of the SCI.

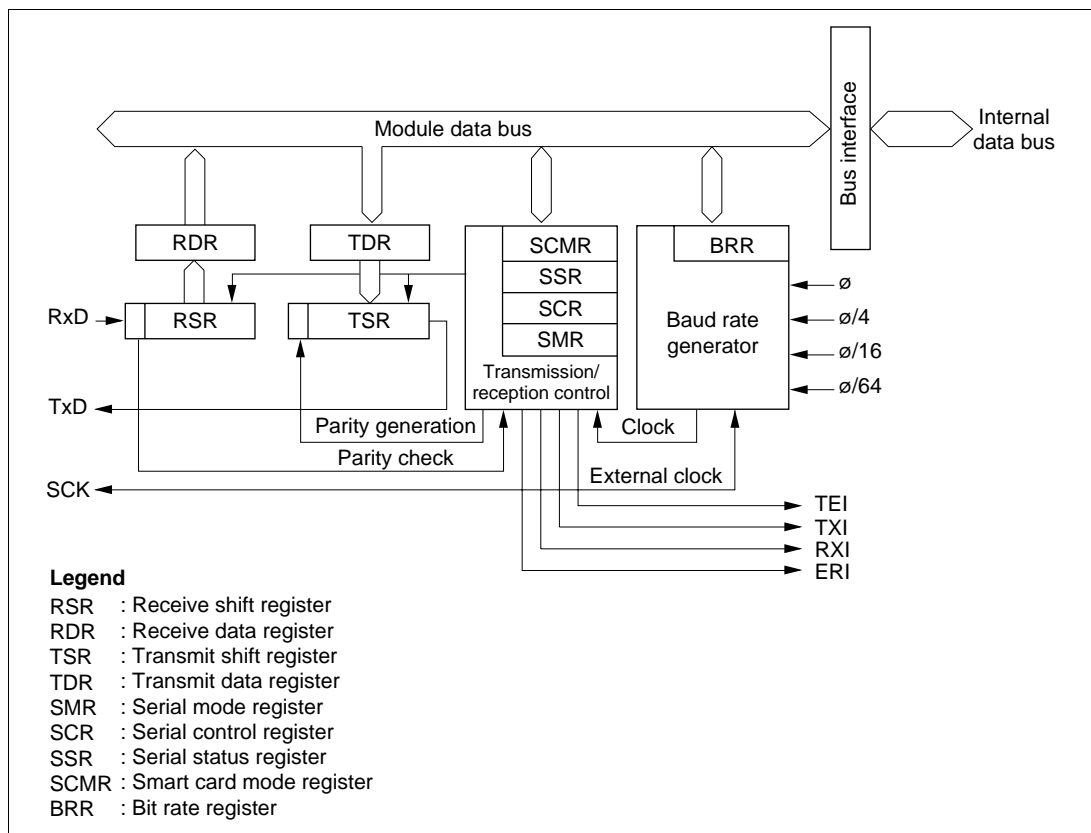


Figure 16-1 Block Diagram of SCI

### 16.1.3 Pin Configuration

Table 16-1 shows the serial pins for each SCI channel.

**Table 16-1 SCI Pins**

Channel	Pin Name	Symbol*	I/O	Function
0	Serial clock pin 0	SCK0	I/O	SCI0 clock input/output
	Receive data pin 0	RxD0/IrRxD	Input	SCI0 receive data input (normal/IrDA)
	Transmit data pin 0	TxD0/IrTxD	Output	SCI0 transmit data output (normal/IrDA)
1	Serial clock pin 1	SCK1	I/O	SCI1 clock input/output
	Receive data pin 1	RxD1	Input	SCI1 receive data input
	Transmit data pin 1	TxD1	Output	SCI1 transmit data output
2	Serial clock pin 2	SCK2	I/O	SCI2 clock input/output
	Receive data pin 2	RxD2	Input	SCI2 receive data input
	Transmit data pin 2	TxD2	Output	SCI2 transmit data output
3	Serial clock pin 3	SCK3	I/O	SCI3 clock input/output
	Receive data pin 3	RxD3	Input	SCI3 receive data input
	Transmit data pin 3	TxD3	Output	SCI3 transmit data output
4	Serial clock pin 4	SCK4	I/O	SCI4 clock input/output
	Receive data pin 4	RxD4	Input	SCI4 receive data input
	Transmit data pin 4	TxD4	Output	SCI4 transmit data output

Note: \* Pin names SCK, RxD, and TxD are used in the text for all channels, omitting the channel designation.

## 16.1.4 Register Configuration

The SCI has the internal registers shown in table 16-2. These registers are used to specify asynchronous mode or clocked synchronous mode, the data format, and the bit rate, and to control transmitter/receiver.

**Table 16-2 SCI Registers**

Channel	Name	Abbreviation	R/W	Initial Value	Address* <sup>1</sup>
0	Serial mode register 0	SMR0	R/W	H'00	H'FF78* <sup>3</sup>
	Bit rate register 0	BRR0	R/W	H'FF	H'FF79* <sup>3</sup>
	Serial control register 0	SCR0	R/W	H'00	H'FF7A* <sup>3</sup>
	Transmit data register 0	TDR0	R/W	H'FF	H'FF7B* <sup>3</sup>
	Serial status register 0	SSR0	R/(W)* <sup>2</sup>	H'84	H'FF7C* <sup>3</sup>
	Receive data register 0	RDR0	R	H'00	H'FF7D* <sup>3</sup>
	Smart card mode register 0	SCMR0	R/W	H'F2	H'FF7E* <sup>3</sup>
	IrDA control register	IrCR	R/W	H'00	H'FDB0
1	Serial mode register 1	SMR1	R/W	H'00	H'FF80* <sup>3</sup>
	Bit rate register 1	BRR1	R/W	H'FF	H'FF81* <sup>3</sup>
	Serial control register 1	SCR1	R/W	H'00	H'FF82* <sup>3</sup>
	Transmit data register 1	TDR1	R/W	H'FF	H'FF83* <sup>3</sup>
	Serial status register 1	SSR1	R/(W)* <sup>2</sup>	H'84	H'FF84* <sup>3</sup>
	Receive data register 1	RDR1	R	H'00	H'FF85* <sup>3</sup>
	Smart card mode register 1	SCMR1	R/W	H'F2	H'FF86* <sup>3</sup>
2	Serial mode register 2	SMR2	R/W	H'00	H'FF88
	Bit rate register 2	BRR2	R/W	H'FF	H'FF89
	Serial control register 2	SCR2	R/W	H'00	H'FF8A
	Transmit data register 2	TDR2	R/W	H'FF	H'FF8B
	Serial status register 2	SSR2	R/(W)* <sup>2</sup>	H'84	H'FF8C
	Receive data register 2	RDR2	R	H'00	H'FF8D
	Smart card mode register 2	SCMR2	R/W	H'F2	H'FF8E

Channel	Name	Abbreviation	R/W	Initial Value	Address* <sup>1</sup>
3	Serial mode register 3	SMR3	R/W	H'00	H'FDD0
	Bit rate register 3	BRR3	R/W	H'FF	H'FDD1
	Serial control register 3	SCR3	R/W	H'00	H'FDD2
	Transmit data register 3	TDR3	R/W	H'FF	H'FDD3
	Serial status register 3	SSR3	R/(W)* <sup>2</sup>	H'84	H'FDD4
	Receive data register 3	RDR3	R	H'00	H'FDD5
	Smart card mode register 3	SCMR3	R/W	H'F2	H'FDD6
4	Serial mode register 4	SMR4	R/W	H'00	H'FDD8
	Bit rate register 4	BRR4	R/W	H'FF	H'FDD9
	Serial control register 4	SCR4	R/W	H'00	H'FDDA
	Transmit data register 4	TDR4	R/W	H'FF	H'FDDB
	Serial status register 4	SSR4	R/(W)* <sup>2</sup>	H'84	H'FDDC
	Receive data register 4	RDR4	R	H'00	H'FDDD
	Smart card mode register 4	SCMR4	R/W	H'F2	H'FDDE
All	Module stop control register B	MSTPCRB	R/W	H'FF	H'FDE9
	Module stop control register C	MSTPCRC	R/W	H'FF	H'FDEA

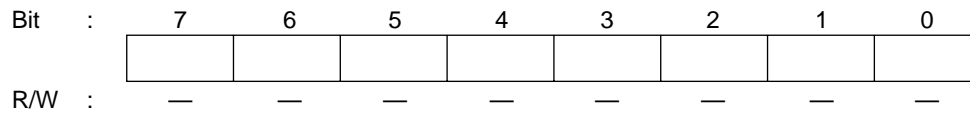
Notes: \*1 Lower 16 bits of the address.

\*2 Only 0 can be written, for flag clearing.

\*3 Some of the SCI registers are allocated to the same addresses as other registers. The IICE bit of the serial timer control register X (SCRX) selects the respective registers.

## 16.2 Register Descriptions

### 16.2.1 Receive Shift Register (RSR)

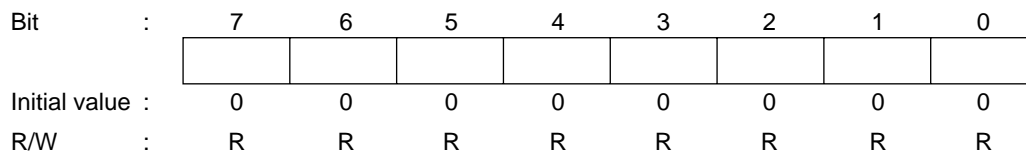


RSR is a register used to receive serial data.

The SCI sets serial data input from the RxD pin in RSR in the order received, starting with the LSB (bit 0), and converts it to parallel data. When one byte of data has been received, it is transferred to RDR automatically.

RSR cannot be directly read or written to by the CPU.

### 16.2.2 Receive Data Register (RDR)



RDR is a register that stores received serial data.

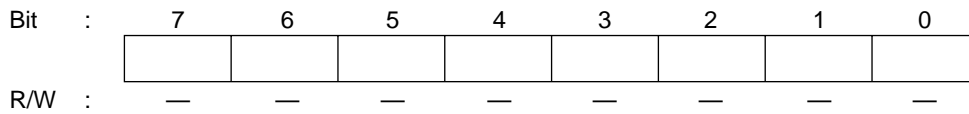
When the SCI has received one byte of serial data, it transfers the received serial data from RSR to RDR where it is stored, and completes the receive operation. After this, RSR is receive-enabled.

Since RSR and RDR function as a double buffer in this way, enables continuous receive operations to be performed.

RDR is a read-only register, and cannot be written to by the CPU.

RDR is initialized to H'00 by a reset, in standby mode, watch mode, subactive mode, and subsleep mode or module stop mode.

### 16.2.3 Transmit Shift Register (TSR)



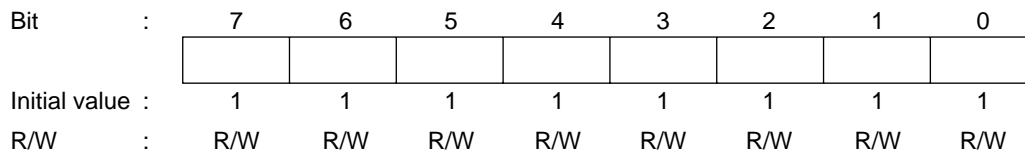
TSR is a register used to transmit serial data.

To perform serial data transmission, the SCI first transfers transmit data from TDR to TSR, then sends the data to the TxD pin starting with the LSB (bit 0).

When transmission of one byte is completed, the next transmit data is transferred from TDR to TSR, and transmission started, automatically. However, data transfer from TDR to TSR is not performed if the TDRE bit in SSR is set to 1.

TSR cannot be directly read or written to by the CPU.

### 16.2.4 Transmit Data Register (TDR)



TDR is an 8-bit register that stores data for serial transmission.

When the SCI detects that TSR is empty, it transfers the transmit data written in TDR to TSR and starts serial transmission. Continuous serial transmission can be carried out by writing the next transmit data to TDR during serial transmission of the data in TSR.

TDR can be read or written to by the CPU at all times.

TDR is initialized to H'FF by a reset, in standby mode, watch mode, subactive mode, and subsleep mode or module stop mode.



### 16.2.5 Serial Mode Register (SMR)

Bit	:	7	6	5	4	3	2	1	0
		C/ $\bar{A}$	CHR	PE	O/ $\bar{E}$	STOP	MP	CKS1	CKS0
Initial value	:	0	0	0	0	0	0	0	0
R/W	:	R/W	R/W	R/W	R/W	R/W	R/W	R/W	R/W

SMR is an 8-bit register used to set the SCI's serial transfer format and select the baud rate generator clock source.

SMR can be read or written to by the CPU at all times.

SMR is initialized to H'00 by a reset and in hardware standby mode.

**Bit 7—Communication Mode (C/ $\bar{A}$ ):** Selects asynchronous mode or clocked synchronous mode as the SCI operating mode.

#### Bit 7

C/ $\bar{A}$	Description
0	Asynchronous mode (Initial value)
1	Clocked synchronous mode

**Bit 6—Character Length (CHR):** Selects 7 or 8 bits as the data length in asynchronous mode. In clocked synchronous mode, a fixed data length of 8 bits is used regardless of the CHR setting.

#### Bit 6

CHR	Description
0	8-bit data (Initial value)
1	7-bit data*

Note: \* When 7-bit data is selected, the MSB (bit 7) of TDR is not transmitted, and it is not possible to choose between LSB-first or MSB-first transfer.

**Bit 5—Parity Enable (PE):** In asynchronous mode, selects whether or not parity bit addition is performed in transmission, and parity bit checking in reception. In clocked synchronous mode with a multiprocessor format, parity bit addition and checking is not performed, regardless of the PE bit setting.

**Bit 5**

PE	Description
0	Parity bit addition and checking disabled (Initial value)
1	Parity bit addition and checking enabled*

Note: \* When the PE bit is set to 1, the parity (even or odd) specified by the O/ $\bar{E}$  bit is added to transmit data before transmission. In reception, the parity bit is checked for the parity (even or odd) specified by the O/ $\bar{E}$  bit.

**Bit 4—Parity Mode (O/ $\bar{E}$ ):** Selects either even or odd parity for use in parity addition and checking.

The O/ $\bar{E}$  bit setting is only valid when the PE bit is set to 1, enabling parity bit addition and checking, in asynchronous mode. The O/ $\bar{E}$  bit setting is invalid in clocked synchronous mode, when parity addition and checking is disabled in asynchronous mode, and when a multiprocessor format is used.

**Bit 4**

O/ $\bar{E}$	Description
0	Even parity* <sup>1</sup> (Initial value)
1	Odd parity* <sup>2</sup>

Notes: \*<sup>1</sup> When even parity is set, parity bit addition is performed in transmission so that the total number of 1 bits in the transmit character plus the parity bit is even.

In reception, a check is performed to see if the total number of 1 bits in the receive character plus the parity bit is even.

\*<sup>2</sup> When odd parity is set, parity bit addition is performed in transmission so that the total number of 1 bits in the transmit character plus the parity bit is odd.

In reception, a check is performed to see if the total number of 1 bits in the receive character plus the parity bit is odd.

**Bit 3—Stop Bit Length (STOP):** Selects 1 or 2 bits as the stop bit length in asynchronous mode. The STOP bits setting is only valid in asynchronous mode. If clocked synchronous mode is set the STOP bit setting is invalid since stop bits are not added.

**Bit 3**

STOP	Description
0	1 stop bit: In transmission, a single 1 bit (stop bit) is added to the end of a transmit character before it is sent. (Initial value)
1	2 stop bits: In transmission, two 1 bits (stop bits) are added to the end of a transmit character before it is sent.

In reception, only the first stop bit is checked, regardless of the STOP bit setting. If the second stop bit is 1, it is treated as a stop bit; if it is 0, it is treated as the start bit of the next transmit character.

**Bit 2—Multiprocessor Mode (MP):** Selects multiprocessor format. When multiprocessor format is selected, the PE bit and  $O/\bar{E}$  bit parity settings are invalid. The MP bit setting is only valid in asynchronous mode; it is invalid in clocked synchronous mode.

For details of the multiprocessor communication function, see section 16.3.3, Multiprocessor Communication Function.

**Bit 2**

MP	Description
0	Multiprocessor function disabled (Initial value)
1	Multiprocessor format selected

**Bits 1 and 0—Clock Select 1 and 0 (CKS1, CKS0):** These bits select the clock source for the baud rate generator. The clock source can be selected from  $\phi$ ,  $\phi/4$ ,  $\phi/16$ , and  $\phi/64$ , according to the setting of bits CKS1 and CKS0.

For the relation between the clock source, the bit rate register setting, and the baud rate, see section 16.2.8, Bit Rate Register (BRR).

Bit 1	Bit 0	Description
CKS1	CKS0	
0	0	$\phi$ clock (Initial value)
	1	$\phi/4$ clock
1	0	$\phi/16$ clock
	1	$\phi/64$ clock

### 16.2.6 Serial Control Register (SCR)

Bit	:	7	6	5	4	3	2	1	0
		TIE	RIE	TE	RE	MPIE	TEIE	CKE1	CKE0
Initial value	:	0	0	0	0	0	0	0	0
R/W	:	R/W	R/W	R/W	R/W	R/W	R/W	R/W	R/W

SCR is a register that performs enabling or disabling of SCI transfer operations, serial clock output in asynchronous mode, and interrupt requests, and selection of the serial clock source.

SCR can be read or written to by the CPU at all times.

SCR is initialized to H'00 by a reset and in standby mode.

**Bit 7—Transmit Interrupt Enable (TIE):** Enables or disables transmit data empty interrupt (TXI) request generation when serial transmit data is transferred from TDR to TSR and the TDRE flag in SSR is set to 1.

Bit 7	Description
TIE	
0	Transmit data empty interrupt (TXI) requests disabled (Initial value)
1	Transmit data empty interrupt (TXI) requests enabled

Note: TXI interrupt request cancellation can be performed by reading 1 from the TDRE flag, then clearing it to 0, or clearing the TIE bit to 0.

**Bit 6—Receive Interrupt Enable (RIE):** Enables or disables receive data full interrupt (RXI) request and receive error interrupt (ERI) request generation when serial receive data is transferred from RSR to RDR and the RDRF flag in SSR is set to 1.

**Bit 6**

<b>RIE</b>	<b>Description</b>
0	Receive data full interrupt (RXI) request and receive error interrupt (ERI) request disabled* (Initial value)
1	Receive data full interrupt (RXI) request and receive error interrupt (ERI) request enabled

Note:\* RXI and ERI interrupt request cancellation can be performed by reading 1 from the RDRF flag, or the FER, PER, or ORER flag, then clearing the flag to 0, or clearing the RIE bit to 0.

**Bit 5—Transmit Enable (TE):** Enables or disables the start of serial transmission by the SCI.

**Bit 5**

<b>TE</b>	<b>Description</b>
0	Transmission disabled* <sup>1</sup> (Initial value)
1	Transmission enabled* <sup>2</sup>

Notes: \*1 The TDRE flag in SSR is fixed at 1.

\*2 In this state, serial transmission is started when transmit data is written to TDR and the TDRE flag in SSR is cleared to 0.

SMR setting must be performed to decide the transfer format before setting the TE bit to 1.

**Bit 4—Receive Enable (RE):** Enables or disables the start of serial reception by the SCI.

**Bit 4**

<b>RE</b>	<b>Description</b>
0	Reception disabled* <sup>1</sup> (Initial value)
1	Reception enabled* <sup>2</sup>

Notes: \*1 Clearing the RE bit to 0 does not affect the RDRF, FER, PER, and ORER flags, which retain their states.

\*2 Serial reception is started in this state when a start bit is detected in asynchronous mode or serial clock input is detected in clocked synchronous mode.

SMR setting must be performed to decide the transfer format before setting the RE bit to 1.

**Bit 3—Multiprocessor Interrupt Enable (MPIE):** Enables or disables multiprocessor interrupts. The MPIE bit setting is only valid in asynchronous mode when the MP bit in SMR is set to 1.

The MPIE bit setting is invalid in clocked synchronous mode or when the MP bit is cleared to 0.

**Bit 3**

<b>MPIE</b>	<b>Description</b>
0	Multiprocessor interrupts disabled (normal reception performed) (Initial value) [Clearing conditions] <ul style="list-style-type: none"> <li>• When the MPIE bit is cleared to 0</li> <li>• When MPB= 1 data is received</li> </ul>
1	Multiprocessor interrupts enabled* Receive interrupt (RXI) requests, receive error interrupt (ERI) requests, and setting of the RDRF, FER, and ORER flags in SSR are disabled until data with the multiprocessor bit set to 1 is received.

Note: \*When receive data including MPB = 0 is received, receive data transfer from RSR to RDR, receive error detection, and setting of the RDRF, FER, and ORER flags in SSR, is not performed. When receive data including MPB = 1 is received, the MPB bit in SSR is set to 1, the MPIE bit is cleared to 0 automatically, and generation of RXI and ERI interrupts (when the TIE and RIE bits in SCR are set to 1) and FER and ORER flag setting is enabled.

**Bit 2—Transmit End Interrupt Enable (TEIE):** Enables or disables transmit end interrupt (TEI) request generation when there is no valid transmit data in TDR in MSB data transmission.

**Bit 2**

<b>TEIE</b>	<b>Description</b>
0	Transmit end interrupt (TEI) request disabled* (Initial value)
1	Transmit end interrupt (TEI) request enabled*

Note: \*TEI cancellation can be performed by reading 1 from the TDRE flag in SSR, then clearing it to 0 and clearing the TEND flag to 0, or clearing the TEIE bit to 0.

**Bits 1 and 0—Clock Enable 1 and 0 (CKE1, CKE0):** These bits are used to select the SCI clock source and enable or disable clock output from the SCK pin. The combination of the CKE1 and CKE0 bits determines whether the SCK pin functions as an I/O port, the serial clock output pin, or the serial clock input pin.

The setting of the CKE0 bit, however, is only valid for internal clock operation (CKE1 = 0) in asynchronous mode. The CKE0 bit setting is invalid in clocked synchronous mode, and in the case of external clock operation (CKE1 = 1). Note that the SCI's operating mode must be decided using SMR before setting the CKE1 and CKE0 bits.

For details of clock source selection, see table 16-9 in section 16.3, Operation.

<b>Bit 1</b>	<b>Bit 0</b>	<b>Description</b>	
<b>CKE1</b>	<b>CKE0</b>		
0	0	Asynchronous mode	Internal clock/SCK pin functions as I/O port* <sup>1</sup>
		Clocked synchronous mode	Internal clock/SCK pin functions as serial clock output* <sup>1</sup>
	1	Asynchronous mode	Internal clock/SCK pin functions as clock output* <sup>2</sup>
		Clocked synchronous mode	Internal clock/SCK pin functions as serial clock output
1	0	Asynchronous mode	External clock/SCK pin functions as clock input* <sup>3</sup>
		Clocked synchronous mode	External clock/SCK pin functions as serial clock input
	1	Asynchronous mode	External clock/SCK pin functions as clock input* <sup>3</sup>
		Clocked synchronous mode	External clock/SCK pin functions as serial clock input

Notes: \*1 Initial value

\*2 Outputs a clock of the same frequency as the bit rate.

\*3 Inputs a clock with a frequency 16 times the bit rate.

### 16.2.7 Serial Status Register (SSR)

Bit	:	7	6	5	4	3	2	1	0
		TDRE	RDRF	ORER	FER	PER	TEND	MPB	MPBT
Initial value	:	1	0	0	0	0	1	0	0
R/W	:	R/(W)*	R/(W)*	R/(W)*	R/(W)*	R/(W)*	R	R	R/W

Note: \* Only 0 can be written, to clear the flag.

SSR is an 8-bit register containing status flags that indicate the operating status of the SCI, and multiprocessor bits.

SSR can be read or written to by the CPU at all times. However, 1 cannot be written to flags TDRE, RDRF, ORER, PER, and FER. Also note that in order to clear these flags they must be read as 1 beforehand. The TEND flag and MPB flag are read-only flags and cannot be modified.

SSR is initialized to H'84 by a reset, in standby mode, watch mode, subactive mode, and subsleep mode or module stop mode.

**Bit 7—Transmit Data Register Empty (TDRE):** Indicates that data has been transferred from TDR to TSR and the next serial data can be written to TDR.

#### Bit 7

TDRE	Description
0	[Clearing conditions] <ul style="list-style-type: none"> <li>When 0 is written to TDRE after reading TDRE = 1</li> <li>When the DMAC* or DTC* is activated by a TXI interrupt and writes data to TDR</li> </ul>
1	[Setting conditions] (Initial value) <ul style="list-style-type: none"> <li>When the TE bit in SCR is 0</li> <li>When data is transferred from TDR to TSR and data can be written to TDR</li> </ul>

Note: \* This function is not available in the H8S/2695.



**Bit 6—Receive Data Register Full (RDRF):** Indicates that the received data is stored in RDR.

**Bit 6**

RDRF	Description
0	[Clearing conditions] (Initial value) <ul style="list-style-type: none"> <li>When 0 is written to RDRF after reading RDRF = 1</li> <li>When the DMAC* or DTC* is activated by an RXI interrupt and reads data from RDR</li> </ul>
1	[Setting condition] <p>When serial reception ends normally and receive data is transferred from RSR to RDR</p>

Notes: RDR and the RDRF flag are not affected and retain their previous values when an error is detected during reception or when the RE bit in SCR is cleared to 0.

If reception of the next data is completed while the RDRF flag is still set to 1, an overrun error will occur and the receive data will be lost.

\* This function is not available in the H8S/2695.

**Bit 5—Overrun Error (ORER):** Indicates that an overrun error occurred during reception, causing abnormal termination.

**Bit 5**

ORER	Description
0	[Clearing condition] (Initial value)* <sup>1</sup> <p>When 0 is written to ORER after reading ORER = 1</p>
1	[Setting condition] <p>When the next serial reception is completed while RDRF = 1*<sup>2</sup></p>

Notes: \*<sup>1</sup> The ORER flag is not affected and retains its previous state when the RE bit in SCR is cleared to 0.

\*<sup>2</sup> The receive data prior to the overrun error is retained in RDR, and the data received subsequently is lost. Also, subsequent serial reception cannot be continued while the ORER flag is set to 1. In clocked synchronous mode, serial transmission cannot be continued, either.

**Bit 4—Framing Error (FER):** Indicates that a framing error occurred during reception in asynchronous mode, causing abnormal termination.

**Bit 4**

FER	Description
0	[Clearing condition] (Initial value)* <sup>1</sup> <ul style="list-style-type: none"> <li>When 0 is written to FER after reading FER = 1</li> </ul>
1	[Setting condition] When the SCI checks whether the stop bit at the end of the receive data when reception ends, and the stop bit is 0 * <sup>2</sup>

Notes: \*1 The FER flag is not affected and retains its previous state when the RE bit in SCR is cleared to 0.  
 \*2 In 2-stop-bit mode, only the first stop bit is checked for a value of 0; the second stop bit is not checked. If a framing error occurs, the receive data is transferred to RDR but the RDRF flag is not set. Also, subsequent serial reception cannot be continued while the FER flag is set to 1. In clocked synchronous mode, serial transmission cannot be continued, either.

**Bit 3—Parity Error (PER):** Indicates that a parity error occurred during reception using parity addition in asynchronous mode, causing abnormal termination.

**Bit 3**

PER	Description
0	[Clearing condition] (Initial value)* <sup>1</sup> When 0 is written to PER after reading PER = 1
1	[Setting condition] When, in reception, the number of 1 bits in the receive data plus the parity bit does not match the parity setting (even or odd) specified by the O/E bit in SMR* <sup>2</sup>

Notes: \*1 The PER flag is not affected and retains its previous state when the RE bit in SCR is cleared to 0.  
 \*2 If a parity error occurs, the receive data is transferred to RDR but the RDRF flag is not set. Also, subsequent serial reception cannot be continued while the PER flag is set to 1. In clocked synchronous mode, serial transmission cannot be continued, either.

**Bit 2—Transmit End (TEND):** Indicates that there is no valid data in TDR when the last bit of the transmit character is sent, and transmission has been ended.

The TEND flag is read-only and cannot be modified.

**Bit 2**

TEND	Description
0	[Clearing conditions] <ul style="list-style-type: none"> <li>When 0 is written to TDRE after reading TDRE = 1</li> <li>When the DMAC* or DTC* is activated by a TXI interrupt and writes data to TDR</li> </ul>
1	[Setting conditions] (Initial value) <ul style="list-style-type: none"> <li>When the TE bit in SCR is 0</li> <li>When TDRE = 1 at transmission of the last bit of a 1-byte serial transmit character</li> </ul>

Note: \* This function is not available in the H8S/2695.

**Bit 1—Multiprocessor Bit (MPB):** When reception is performed using multiprocessor format in asynchronous mode, MPB stores the multiprocessor bit in the receive data.

MPB is a read-only bit, and cannot be modified.

**Bit 1**

MPB	Description
0	[Clearing condition] (Initial value)* When data with a 0 multiprocessor bit is received
1	[Setting condition] When data with a 1 multiprocessor bit is received

Note: \* Retains its previous state when the RE bit in SCR is cleared to 0 with multiprocessor format.


**Bit 0—Multiprocessor Bit Transfer (MPBT):** When transmission is performed using multiprocessor format in asynchronous mode, MPBT stores the multiprocessor bit to be added to the transmit data.

The MPBT bit setting is invalid when multiprocessor format is not used, when not transmitting, and in clocked synchronous mode.

**Bit 0**

MPBT	Description
0	Data with a 0 multiprocessor bit is transmitted (Initial value)
1	Data with a 1 multiprocessor bit is transmitted

### 16.2.8 Bit Rate Register (BRR)

Bit	:	7	6	5	4	3	2	1	0
									
Initial value	:	1	1	1	1	1	1	1	1
R/W	:	R/W	R/W	R/W	R/W	R/W	R/W	R/W	R/W

BRR is an 8-bit register that sets the serial transfer bit rate in accordance with the baud rate generator operating clock selected by bits CKS1 and CKS0 in SMR.

BRR can be read or written to by the CPU at all times.

BRR is initialized to H'FF by a reset and in standby mode.

As baud rate generator control is performed independently for each channel, different values can be set for each channel.

Table 16-3 shows sample BRR settings in asynchronous mode, and table 16-4 shows sample BRR settings in clocked synchronous mode.

**Table 16-3 BRR Settings for Various Bit Rates (Asynchronous Mode)**

Bit Rate (bit/s)	$\phi = 2 \text{ MHz}$			$\phi = 2.097152 \text{ MHz}$			$\phi = 2.4576 \text{ MHz}$			$\phi = 3 \text{ MHz}$		
	n	N	Error (%)	n	N	Error (%)	n	N	Error (%)	n	N	Error (%)
110	1	141	0.03	1	148	-0.04	1	174	-0.26	1	212	0.03
150	1	103	0.16	1	108	0.21	1	127	0.00	1	155	0.16
300	0	207	0.16	0	217	0.21	0	255	0.00	1	77	0.16
600	0	103	0.16	0	108	0.21	0	127	0.00	0	155	0.16
1200	0	51	0.16	0	54	-0.70	0	63	0.00	0	77	0.16
2400	0	25	0.16	0	26	1.14	0	31	0.00	0	38	0.16
4800	0	12	0.16	0	13	-2.48	0	15	0.00	0	19	-2.34
9600	—	—	—	0	6	-2.48	0	7	0.00	0	9	-2.34
19200	—	—	—	—	—	—	0	3	0.00	0	4	-2.34
31250	0	1	0.00	—	—	—	—	—	—	0	2	0.00
38400	—	—	—	—	—	—	0	1	0.00	—	—	—

Bit Rate (bit/s)	$\phi = 3.6864 \text{ MHz}$			$\phi = 4 \text{ MHz}$			$\phi = 4.9152 \text{ MHz}$			$\phi = 5 \text{ MHz}$		
	n	N	Error (%)	n	N	Error (%)	n	N	Error (%)	n	N	Error (%)
110	2	64	0.70	2	70	0.03	2	86	0.31	2	88	-0.25
150	1	191	0.00	1	207	0.16	1	255	0.00	2	64	0.16
300	1	95	0.00	1	103	0.16	1	127	0.00	1	129	0.16
600	0	191	0.00	0	207	0.16	0	255	0.00	1	64	0.16
1200	0	95	0.00	0	103	0.16	0	127	0.00	0	129	0.16
2400	0	47	0.00	0	51	0.16	0	63	0.00	0	64	0.16
4800	0	23	0.00	0	25	0.16	0	31	0.00	0	32	-1.36
9600	0	11	0.00	0	12	0.16	0	15	0.00	0	15	1.73
19200	0	5	0.00	—	—	—	0	7	0.00	0	7	1.73
31250	—	—	—	0	3	0.00	0	4	-1.70	0	4	0.00
38400	0	2	0.00	—	—	—	0	3	0.00	0	3	1.73

Bit Rate (bit/s)	$\phi = 6 \text{ MHz}$			$\phi = 6.144 \text{ MHz}$			$\phi = 7.3728 \text{ MHz}$			$\phi = 8 \text{ MHz}$		
	n	N	Error (%)	n	N	Error (%)	n	N	Error (%)	n	N	Error (%)
110	2	106	-0.44	2	108	0.08	2	130	-0.07	2	141	0.03
150	2	77	0.16	2	79	0.00	2	95	0.00	2	103	0.16
300	1	155	0.16	1	159	0.00	1	191	0.00	1	207	0.16
600	1	77	0.16	1	79	0.00	1	95	0.00	1	103	0.16
1200	0	155	0.16	0	159	0.00	0	191	0.00	0	207	0.16
2400	0	77	0.16	0	79	0.00	0	95	0.00	0	103	0.16
4800	0	38	0.16	0	39	0.00	0	47	0.00	0	51	0.16
9600	0	19	-2.34	0	19	0.00	0	23	0.00	0	25	0.16
19200	0	9	-2.34	0	9	0.00	0	11	0.00	0	12	0.16
31250	0	5	0.00	0	5	2.40	—	—	—	0	7	0.00
38400	0	4	-2.34	0	4	0.00	0	5	0.00	—	—	—

Bit Rate (bit/s)	$\phi = 9.8304 \text{ MHz}$			$\phi = 10 \text{ MHz}$			$\phi = 12 \text{ MHz}$			$\phi = 12.288 \text{ MHz}$		
	n	N	Error (%)	n	N	Error (%)	n	N	Error (%)	n	N	Error (%)
110	2	174	-0.26	2	177	-0.25	2	212	0.03	2	217	0.08
150	2	127	0.00	2	129	0.16	2	155	0.16	2	159	0.00
300	1	255	0.00	2	64	0.16	2	77	0.16	2	79	0.00
600	1	127	0.00	1	129	0.16	1	155	0.16	1	159	0.00
1200	0	255	0.00	1	64	0.16	1	77	0.16	1	79	0.00
2400	0	127	0.00	0	129	0.16	0	155	0.16	0	159	0.00
4800	0	63	0.00	0	64	0.16	0	77	0.16	0	79	0.00
9600	0	31	0.00	0	32	-1.36	0	38	0.16	0	39	0.00
19200	0	15	0.00	0	15	1.73	0	19	-2.34	0	19	0.00
31250	0	9	-1.70	0	9	0.00	0	11	0.00	0	11	2.40
38400	0	7	0.00	0	7	1.73	0	9	-2.34	0	9	0.00

Bit Rate (bit/s)	$\phi = 14$ MHz			$\phi = 14.7456$ MHz			$\phi = 16$ MHz			$\phi = 17.2032$ MHz		
	n	N	Error (%)	n	N	Error (%)	n	N	Error (%)	n	N	Error (%)
	110	2	248	-0.17	3	64	0.70	3	70	0.03	3	75
150	2	181	0.16	2	191	0.00	2	207	0.16	2	223	0.00
300	2	90	0.16	2	95	0.00	2	103	0.16	2	111	0.00
600	1	181	0.16	1	191	0.00	1	207	0.16	1	223	0.00
1200	1	90	0.16	1	95	0.00	1	103	0.16	1	111	0.00
2400	0	181	0.16	0	191	0.00	0	207	0.16	0	223	0.00
4800	0	90	0.16	0	95	0.00	0	103	0.16	0	111	0.00
9600	0	45	-0.93	0	47	0.00	0	51	0.16	0	55	0.00
19200	0	22	-0.93	0	23	0.00	0	25	0.16	0	27	0.00
31250	0	13	0.00	0	14	-1.70	0	15	0.00	0	16	1.20
38400	—	—	—	0	11	0.00	0	12	0.13	0	13	0.00

Bit Rate (bit/s)	$\phi = 18$ MHz			$\phi = 19.6608$ MHz			$\phi = 20$ MHz			$\phi = 25$ MHz			$\phi = 28$ MHz		
	n	N	Error (%)	n	N	Error (%)	n	N	Error (%)	n	N	Error (%)	n	N	Error (%)
	110	3	79	-0.12	3	86	0.31	3	88	-0.25	3	110	-0.02	3	123
150	2	233	0.16	2	255	0.00	3	64	0.16	3	80	-0.47	3	90	0.16
300	2	116	0.16	2	127	0.00	2	129	0.16	2	162	0.15	2	181	0.16
600	1	233	0.16	1	255	0.00	2	64	0.16	2	80	-0.47	2	90	0.16
1200	1	116	0.16	1	127	0.00	1	129	0.16	1	162	0.15	1	181	0.16
2400	0	233	0.16	0	255	0.00	1	64	0.16	1	80	-0.47	1	90	0.16
4800	0	116	0.16	0	127	0.00	0	129	0.16	0	162	0.15	0	181	0.16
9600	0	58	-0.69	0	63	0.00	0	64	0.16	0	80	-0.47	0	90	0.16
19200	0	28	1.02	0	31	0.00	0	32	-1.36	0	40	-0.76	0	45	-0.93
31250	0	17	0.00	0	19	-1.70	0	19	0.00	0	24	0.00	0	27	0.00
38400	0	14	-2.34	0	15	0.00	0	15	1.73	0	19	1.73	0	22	-0.93

**Table 16-4 BRR Settings for Various Bit Rates (Clocked Synchronous Mode)**

Bit Rate (bit/s)	$\varnothing =$ 2 MHz		$\varnothing =$ 4 MHz		$\varnothing =$ 8 MHz		$\varnothing =$ 10 MHz		$\varnothing =$ 16 MHz		$\varnothing =$ 20 MHz		$\varnothing =$ 25 MHz		$\varnothing =$ 28 MHz	
	n	N	n	N	n	N	n	N	n	N	n	N	n	N	n	N
	110	3	70	—	—											
250	2	124	2	249	3	124	—	—	3	249						
500	1	249	2	124	2	249	—	—	3	124	—	—			3	218
1 k	1	124	1	249	2	124	—	—	2	249	—	—	3	97	3	108
2.5 k	0	199	1	99	1	199	1	249	2	99	2	124	2	155	2	174
5 k	0	99	0	199	1	99	1	124	1	199	1	249	2	77	1	349
10 k	0	49	0	99	0	199	0	249	1	99	1	124	1	155	1	174
25 k	0	19	0	39	0	79	0	99	0	159	0	199	0	249	0	279
50 k	0	9	0	19	0	39	0	49	0	79	0	99	0	124	0	139
100 k	0	4	0	9	0	19	0	24	0	39	0	49	0	62	0	69
250 k	0	1	0	3	0	7	0	9	0	15	0	19	0	24	0	27
500 k	0	0*	0	1	0	3	0	4	0	7	0	9	—	—	0	13
1 M			0	0*	0	1			0	3	0	4	—	—	0	6
2.5 M							0	0*			0	1	—	—	—	—
5 M											0	0*	—	—	—	—

Note: As far as possible, the setting should be made so that the error is no more than 1%.

**Legend**

Blank : Cannot be set.

— : Can be set, but there will be a degree of error.

\* : Continuous transfer is not possible.



The BRR setting is found from the following formulas.

Asynchronous mode:

$$N = \frac{\phi}{64 \times 2^{2n-1} \times B} \times 10^6 - 1$$

Clocked synchronous mode:

$$N = \frac{\phi}{8 \times 2^{2n-1} \times B} \times 10^6 - 1$$

Where B: Bit rate (bit/s)

N: BRR setting for baud rate generator ( $0 \leq N \leq 255$ )

$\phi$ : Operating frequency (MHz)

n: Baud rate generator input clock (n = 0 to 3)

(See the table below for the relation between n and the clock.)

n	Clock	SMR Setting	
		CKS1	CKS0
0	$\phi$	0	0
1	$\phi/4$	0	1
2	$\phi/16$	1	0
3	$\phi/64$	1	1

The bit rate error in asynchronous mode is found from the following formula:

$$\text{Error (\%)} = \left\{ \frac{\phi \times 10^6}{(N + 1) \times B \times 64 \times 2^{2n-1}} - 1 \right\} \times 100$$

Table 16-5 shows the maximum bit rate for each frequency in asynchronous mode. Tables 16-6 and 16-7 show the maximum bit rates with external clock input.

**Table 16-5 Maximum Bit Rate for Each Frequency (Asynchronous Mode)**

<b>ø (MHz)</b>	<b>Maximum Bit Rate (bit/s)</b>	<b>n</b>	<b>N</b>
2	62500	0	0
2.097152	65536	0	0
2.4576	76800	0	0
3	93750	0	0
3.6864	115200	0	0
4	125000	0	0
4.9152	153600	0	0
5	156250	0	0
6	187500	0	0
6.144	192000	0	0
7.3728	230400	0	0
8	250000	0	0
9.8304	307200	0	0
10	312500	0	0
12	375000	0	0
12.288	384000	0	0
14	437500	0	0
14.7456	460800	0	0
16	500000	0	0
17.2032	537600	0	0
18	562500	0	0
19.6608	614400	0	0
20	625000	0	0
25	781250	0	0
28	875000	0	0

**Table 16-6 Maximum Bit Rate with External Clock Input (Asynchronous Mode)**

<b>ø (MHz)</b>	<b>External Input Clock (MHz)</b>	<b>Maximum Bit Rate (bit/s)</b>
2	0.5000	31250
2.097152	0.5243	32768
2.4576	0.6144	38400
3	0.7500	46875
3.6864	0.9216	57600
4	1.0000	62500
4.9152	1.2288	76800
5	1.2500	78125
6	1.5000	93750
6.144	1.5360	96000
7.3728	1.8432	115200
8	2.0000	125000
9.8304	2.4576	153600
10	2.5000	156250
12	3.0000	187500
12.288	3.0720	192000
14	3.5000	218750
14.7456	3.6864	230400
16	4.0000	250000
17.2032	4.3008	268800
18	4.5000	281250
19.6608	4.9152	307200
20	5.0000	312500
25	6.2500	390625
28	7.0000	437500

**Table 16-7 Maximum Bit Rate with External Clock Input (Clocked Synchronous Mode)**

<b>ø (MHz)</b>	<b>External Input Clock (MHz)</b>	<b>Maximum Bit Rate (bit/s)</b>
2	0.3333	333333.3
4	0.6667	666666.7
6	1.0000	1000000.0
8	1.3333	1333333.3
10	1.6667	1666666.7
12	2.0000	2000000.0
14	2.3333	2333333.3
16	2.6667	2666666.7
18	3.0000	3000000.0
20	3.3333	3333333.3
25	4.1667	4166666.7
28	4.6667	4666666.7

### 16.2.9 Smart Card Mode Register (SCMR)

Bit	:	7	6	5	4	3	2	1	0
		—	—	—	—	SDIR	SINV	—	SMIF
Initial value	:	1	1	1	1	0	0	1	0
R/W	:	—	—	—	—	R/W	R/W	—	R/W

SCMR selects LSB-first or MSB-first by means of bit SDIR. Except in the case of asynchronous mode 7-bit data, LSB-first or MSB-first can be selected regardless of the serial communication mode. The descriptions in this chapter refer to LSB-first transfer.

For details of the other bits in SCMR, see section 17.2.1, Smart Card Mode Register (SCMR).

SCMR is initialized to HF2 by a reset and in standby mode.

**Bits 7 to 4—Reserved:** These bits are always read as 1 and cannot be modified.

**Bit 3—Smart Card Data Transfer Direction (SDIR):** Selects the serial/parallel conversion format.

This bit is valid when 8-bit data is used as the transmit/receive format.

#### Bit 3

SDIR	Description
0	TDR contents are transmitted LSB-first (Initial value) Receive data is stored in RDR LSB-first
1	TDR contents are transmitted MSB-first Receive data is stored in RDR MSB-first

**Bit 2—Smart Card Data Invert (SINV):** Specifies inversion of the data logic level. The SINV bit does not affect the logic level of the parity bit(s); parity bit inversion requires inversion of the  $O/\bar{E}$  bit in SMR.

#### Bit 2

SINV	Description
0	TDR contents are transmitted without modification (Initial value) Receive data is stored in RDR without modification
1	TDR contents are inverted before being transmitted Receive data is stored in RDR in inverted form

**Bit 1—Reserved:** This bit is always read as 1 and cannot be modified.

**Bit 0—Smart Card Interface Mode Select (SMIF):** When the smart card interface operates as a normal SCI, 0 should be written in this bit.

**Bit 0**

SMIF	Description
0	Operates as normal SCI (smart card interface function disabled) (Initial value)
1	Smart card interface function enabled

**16.2.10 IrDA Control Register (IrCR)**

Bit	:	7	6	5	4	3	2	1	0
		IrE	IrCKS2	IrCKS1	IrCKS0	—	—	—	—
Initial value :		0	0	0	0	0	0	0	0
R/W	:	R/W	R/W	R/W	R/W	—	—	—	—

IrCR is an 8-bit read/write register that selects the SCI0 function.

IrCR is initialized to H'00 when in hardware standby mode.

Note: This register's functions are not supported in the H8S/2695. Only 0 should be written to this register.

**Bit 7—IrDA enable (IrE):** Sets SCI0 input and output for normal SCI operation or IrDA operation.

**Bit 7**

IrE	Description
0	TxD0/IrTxD and RxD0/IrRxD pins operate as TxD0 and RxD0 (Initial value)
1	TxD0/IrTxD and RxD0/IrRxD pins operate as IrTxD and IrRxD

**Bits 6 to 4—IrDA clock select 2 to 0 (IrCKS2 to IrCKS0):** When the IrDA function is enabled, these bits set the width of the High pulse when encoding the IrTxD output pulse.

Bit 6	Bit 5	Bit 4	Description
IrCKS2	IrCKS1	IrCKS0	
0	0	0	B×3/16 (three sixteenths of bit rate) (Initial value)
		1	ø/2
	1	0	ø/4
		1	ø/8
1	0	0	ø/16
		1	ø/32
	1	0	ø/64
		1	ø/128

**Bits 3 to 0—Reserved:** These bits are always read as 0 and cannot be modified.

### 16.2.11 Module Stop Control Registers B and C (MSTPCRB, MSTPCRC)

#### MSTPCRB

Bit	:	7	6	5	4	3	2	1	0
		MSTPB7	MSTPB6	MSTPB5	MSTPB4	MSTPB3	MSTPB2	MSTPB1	MSTPB0
Initial value	:	1	1	1	1	1	1	1	1
R/W	:	R/W	R/W	R/W	R/W	R/W	R/W	R/W	R/W

#### MSTPCRC

Bit	:	7	6	5	4	3	2	1	0
		MSTPC7	MSTPC6	MSTPC5	MSTPC4	MSTPC3	MSTPC2	MSTPC1	MSTPC0
Initial value	:	1	1	1	1	1	1	1	1
R/W	:	R/W	R/W	R/W	R/W	R/W	R/W	R/W	R/W

MSTPCRB and MSTPCRC are 8-bit readable/writable registers that perform module stop mode control.

Setting any of bits MSTPB7 to MSTBP5 and MSTPC7 and MSTPC6 to 1 stops SCI0 to SCI4 operating and enter module stop mode on completion of the bus cycle. For details, see section 24.5, Module Stop Mode.

MSTPCRB and MSTPCRC are initialized to H'FF by a power-on reset and in hardware standby mode. They are not initialized by a manual reset and in software standby mode.

**(1) Module Stop Control Register B (MSTPCRB)**

**Bit 7—Module Stop (MSTPB7):** Specifies the SCI0 module stop mode.

<b>Bit 7</b>	
<b>MSTPB7</b>	<b>Description</b>
0	SCI0 module stop mode is cleared
1	SCI0 module stop mode is set (Initial value)

**Bit 6—Module Stop (MSTPB6):** Specifies the SCI1 module stop mode.

<b>Bit 6</b>	
<b>MSTPB6</b>	<b>Description</b>
0	SCI1 module stop mode is cleared
1	SCI1 module stop mode is set (Initial value)

**Bit 5—Module Stop (MSTPB5):** Specifies the SCI2 module stop mode.

<b>Bit 5</b>	
<b>MSTPB5</b>	<b>Description</b>
0	SCI2 module stop mode is cleared
1	SCI2 module stop mode is set (Initial value)

**(2) Module Stop Control Register C (MSTPCRC)**

**Bit 7—Module Stop (MSTPC7):** Specifies the SCI3 module stop mode.

<b>Bit 7</b>	
<b>MSTPC7</b>	<b>Description</b>
0	SCI3 module stop mode is cleared
1	SCI3 module stop mode is set (Initial value)



**Bit 6—Module Stop (MSTPC6):** Specifies the SCI4 module stop mode.

**Bit 6**

<b>MSTPC6</b>	<b>Description</b>
0	SCI4 module stop mode is cleared
1	SCI4 module stop mode is set (Initial value)

## 16.3 Operation

### 16.3.1 Overview

The SCI can carry out serial communication in two modes: asynchronous mode in which synchronization is achieved character by character, and clocked synchronous mode in which synchronization is achieved with clock pulses.

Selection of asynchronous or clocked synchronous mode and the transmission format is made using SMR as shown in table 16-8. The SCI clock is determined by a combination of the C/A bit in SMR and the CKE1 and CKE0 bits in SCR, as shown in table 16-9.

#### Asynchronous Mode

- Data length: Choice of 7 or 8 bits
- Choice of parity addition, multiprocessor bit addition, and addition of 1 or 2 stop bits (the combination of these parameters determines the transfer format and character length)
- Detection of framing, parity, and overrun errors, and breaks, during reception
- Choice of internal or external clock as SCI clock source
  - When internal clock is selected:  
The SCI operates on the baud rate generator clock and a clock with the same frequency as the bit rate can be output
  - When external clock is selected:  
A clock with a frequency of 16 times the bit rate must be input (the on-chip baud rate generator is not used)

#### Clocked Synchronous Mode

- Transfer format: Fixed 8-bit data
- Detection of overrun errors during reception
- Choice of internal or external clock as SCI clock source

— When internal clock is selected:

The SCI operates on the baud rate generator clock and a serial clock is output off-chip

— When external clock is selected:

The on-chip baud rate generator is not used, and the SCI operates on the input serial clock

**Table 16-8 SMR Settings and Serial Transfer Format Selection**

SMR Settings						SCI Transfer Format									
Bit 7	Bit 6	Bit 2	Bit 5	Bit 3	Mode	Data Length	Multi Processor Bit	Parity Bit	Stop Bit Length						
C/ $\bar{A}$	CHR	MP	PE	STOP											
0	0	0	0	0	Asynchronous mode	8-bit data	No	No	1 bit						
				1					2 bits						
				1	0				Asynchronous mode (multi-processor format)	8-bit data	Yes	No	1 bit		
					1								2 bits		
				1	0				—	—	0	Asynchronous mode (multi-processor format)	7-bit data	No	1 bit
											1				2 bits
											0				1 bit
											1				2 bits
1	—	—	—	—	Clocked synchronous mode	8-bit data	No	None							

**Table 16-9 SMR and SCR Settings and SCI Clock Source Selection**

SMR Bit 7 C/ $\bar{A}$	SCR Setting		Mode	SCI Transmit/Receive Clock	
	Bit 1 CKE1	Bit 0 CKE0		Clock Source	SCK Pin Function
0	0	0	Asynchronous mode	Internal	SCI does not use SCK pin
		1			Outputs clock with same frequency as bit rate
1	0	0	Clock synchronous mode	Internal	Outputs serial clock
		1			
1	1	0	Clock synchronous mode	External	Inputs clock with frequency of 16 times the bit rate
		1			Inputs serial clock

### 16.3.2 Operation in Asynchronous Mode

In asynchronous mode, characters are sent or received, each preceded by a start bit indicating the start of communication and stop bits indicating the end of communication. Serial communication is thus carried out with synchronization established on a character-by-character basis.

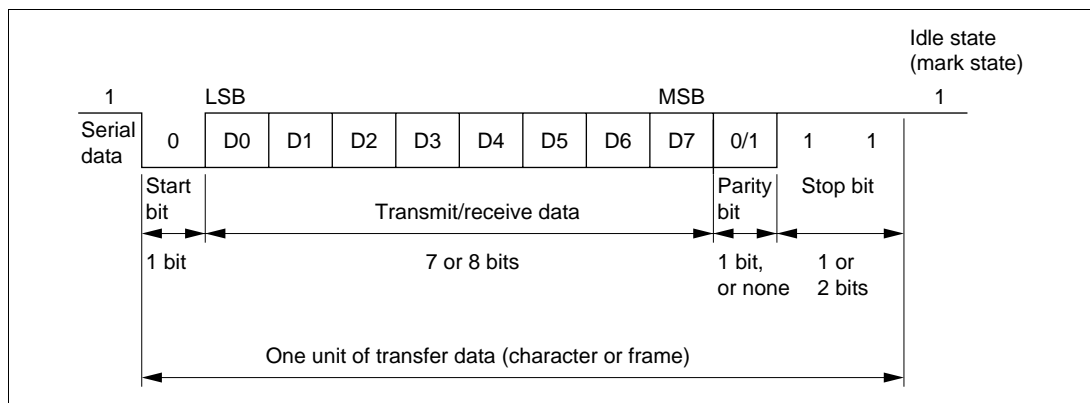
Inside the SCI, the transmitter and receiver are independent units, enabling full-duplex communication. Both the transmitter and the receiver also have a double-buffered structure, so that data can be read or written during transmission or reception, enabling continuous data transfer.

Figure 16-2 shows the general format for asynchronous serial communication.

In asynchronous serial communication, the transmission line is usually held in the mark state (high level). The SCI monitors the transmission line, and when it goes to the space state (low level), recognizes a start bit and starts serial communication.

One serial communication character consists of a start bit (low level), followed by data (in LSB-first order), a parity bit (high or low level), and finally stop bits (high level).

In asynchronous mode, the SCI performs synchronization at the falling edge of the start bit in reception. The SCI samples the data on the 8th pulse of a clock with a frequency of 16 times the length of one bit, so that the transfer data is latched at the center of each bit.



**Figure 16-2 Data Format in Asynchronous Communication  
(Example with 8-Bit Data, Parity, Two Stop Bits)**

**Data Transfer Format:** Table 16-10 shows the data transfer formats that can be used in asynchronous mode. Any of 12 transfer formats can be selected according to the SMR setting.

**Table 16-10 Serial Transfer Formats (Asynchronous Mode)**

SMR Settings				Serial Transfer Format and Frame Length												
CHR	PE	MP	STOP	1	2	3	4	5	6	7	8	9	10	11	12	
0	0	0	0	S	8-bit data								STOP			
0	0	0	1	S	8-bit data								STOP	STOP		
0	1	0	0	S	8-bit data								P	STOP		
0	1	0	1	S	8-bit data								P	STOP	STOP	
1	0	0	0	S	7-bit data							STOP				
1	0	0	1	S	7-bit data							STOP	STOP			
1	1	0	0	S	7-bit data							P	STOP			
1	1	0	1	S	7-bit data							P	STOP	STOP		
0	—	1	0	S	8-bit data								MPB	STOP		
0	—	1	1	S	8-bit data								MPB	STOP	STOP	
1	—	1	0	S	7-bit data							MPB	STOP			
1	—	1	1	S	7-bit data							MPB	STOP	STOP		

**Legend**

S : Start bit

STOP : Stop bit

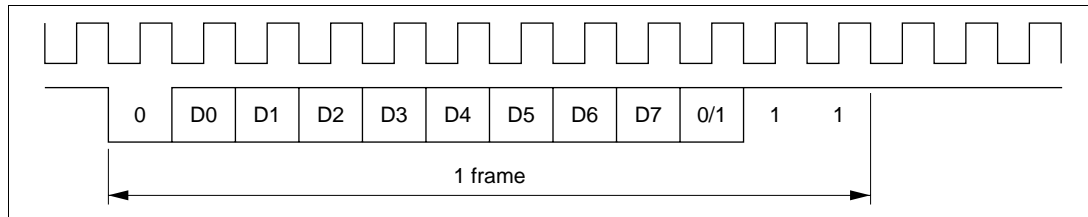
P : Parity bit

MPB : Multiprocessor bit

**Clock:** Either an internal clock generated by the on-chip baud rate generator or an external clock input at the SCK pin can be selected as the SCI's serial clock, according to the setting of the  $C/\bar{A}$  bit in SMR and the CKE1 and CKE0 bits in SCR. For details of SCI clock source selection, see table 16-9.

When an external clock is input at the SCK pin, the clock frequency should be 16 times the bit rate used.

When the SCI is operated on an internal clock, the clock can be output from the SCK pin. The frequency of the clock output in this case is equal to the bit rate, and the phase is such that the rising edge of the clock is in the middle of the transmit data, as shown in figure 16-3.



**Figure 16-3 Relation between Output Clock and Transfer Data Phase (Asynchronous Mode)**

#### Data Transfer Operations:

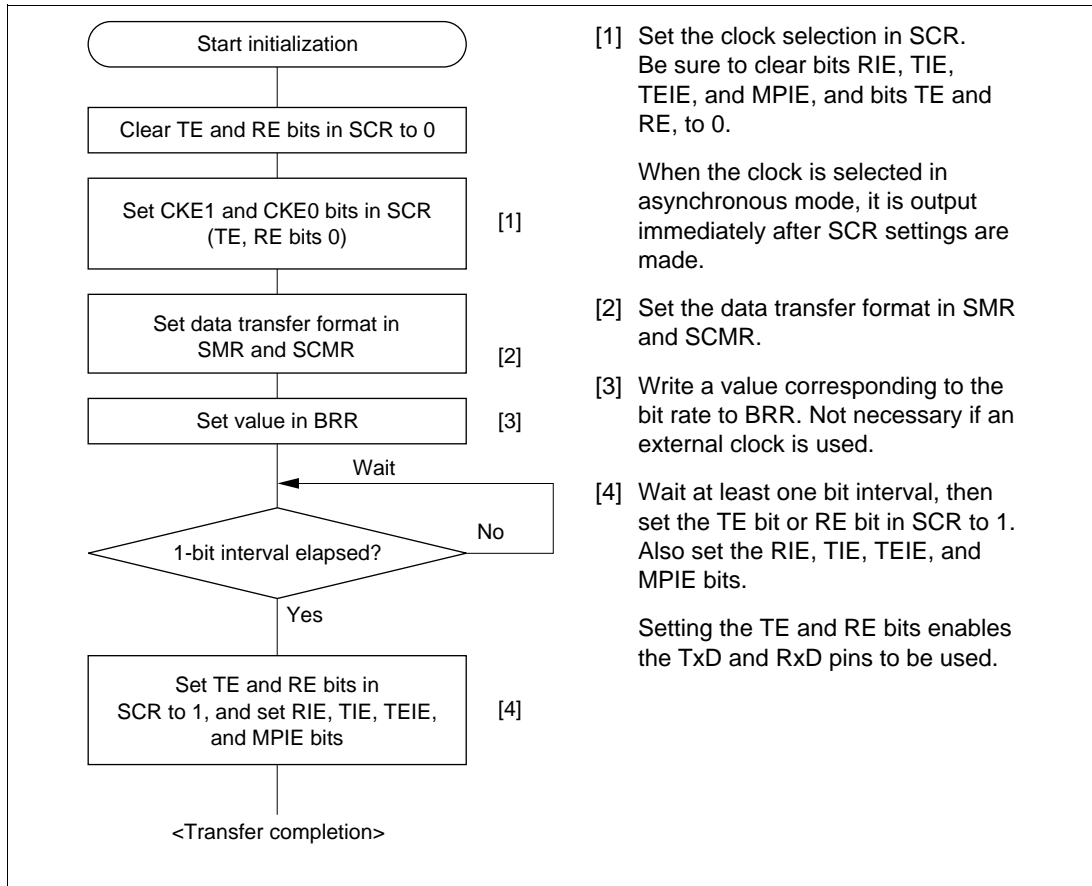
- SCI initialization (asynchronous mode)

Before transmitting and receiving data, you should first clear the TE and RE bits in SCR to 0, then initialize the SCI as described below.

When the operating mode, transfer format, etc., is changed, the TE and RE bits must be cleared to 0 before making the change using the following procedure. When the TE bit is cleared to 0, the TDRE flag is set to 1 and TSR is initialized. Note that clearing the RE bit to 0 does not change the contents of the RDRF, PER, FER, and ORER flags, or the contents of RDR.

When an external clock is used the clock should not be stopped during operation, including initialization, since operation is uncertain.

Figure 16-4 shows a sample SCI initialization flowchart.



**Figure 16-4 Sample SCI Initialization Flowchart**

- Serial data transmission (asynchronous mode)
- Figure 16-5 shows a sample flowchart for serial transmission.  
The following procedure should be used for serial data transmission.

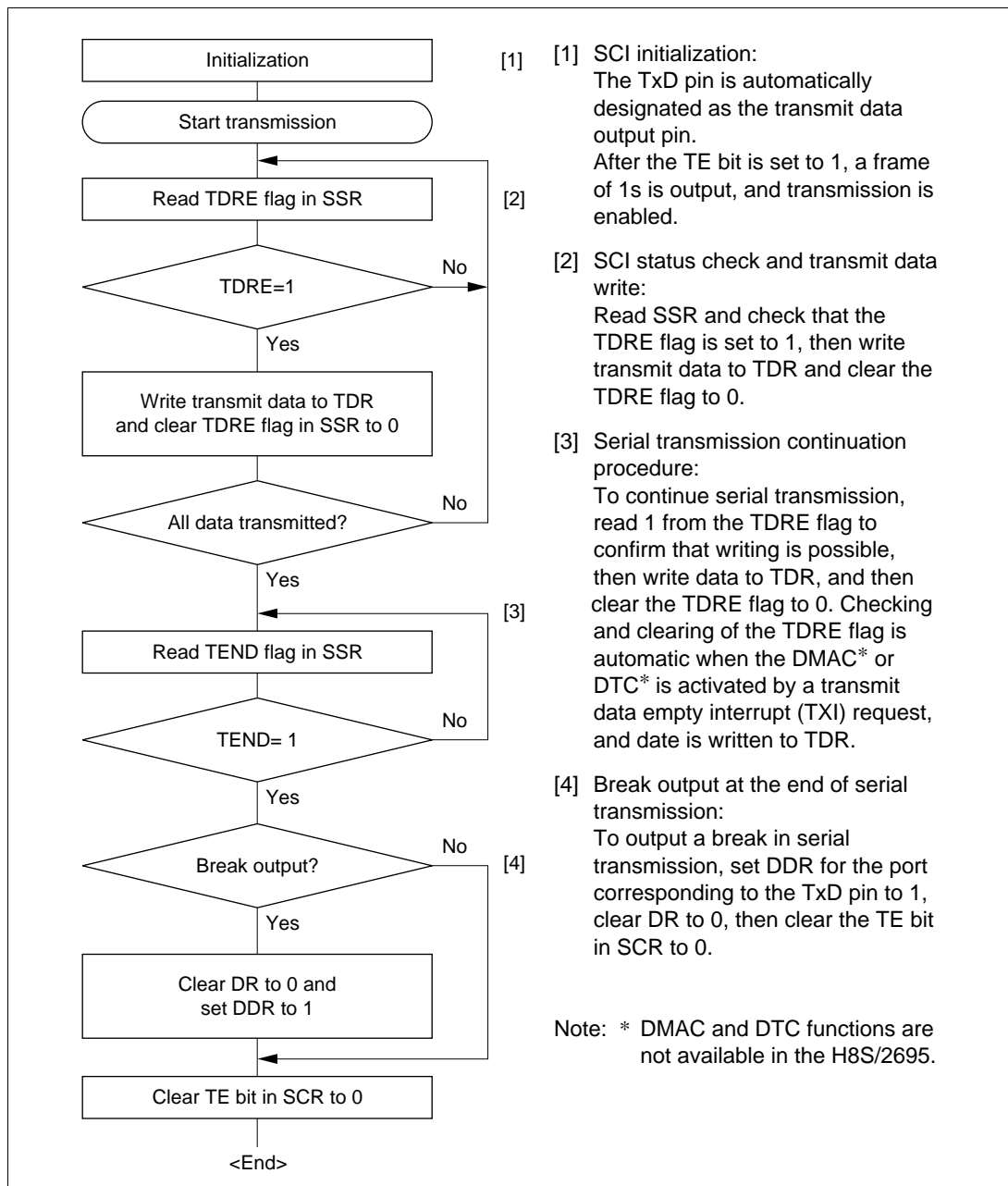


Figure 16-5 Sample Serial Transmission Flowchart



In serial transmission, the SCI operates as described below.

[1] The SCI monitors the TDRE flag in SSR, and if it is 0, recognizes that data has been written to TDR, and transfers the data from TDR to TSR.

[2] After transferring data from TDR to TSR, the SCI sets the TDRE flag to 1 and starts transmission.

If the TIE bit is set to 1 at this time, a transmit data empty interrupt (TXI) is generated.

The serial transmit data is sent from the TxD pin in the following order.

[a] Start bit:

One 0-bit is output.

[b] Transmit data:

8-bit or 7-bit data is output in LSB-first order.

[c] Parity bit or multiprocessor bit:

One parity bit (even or odd parity), or one multiprocessor bit is output.

A format in which neither a parity bit nor a multiprocessor bit is output can also be selected.

[d] Stop bit(s):

One or two 1-bits (stop bits) are output.

[e] Mark state:

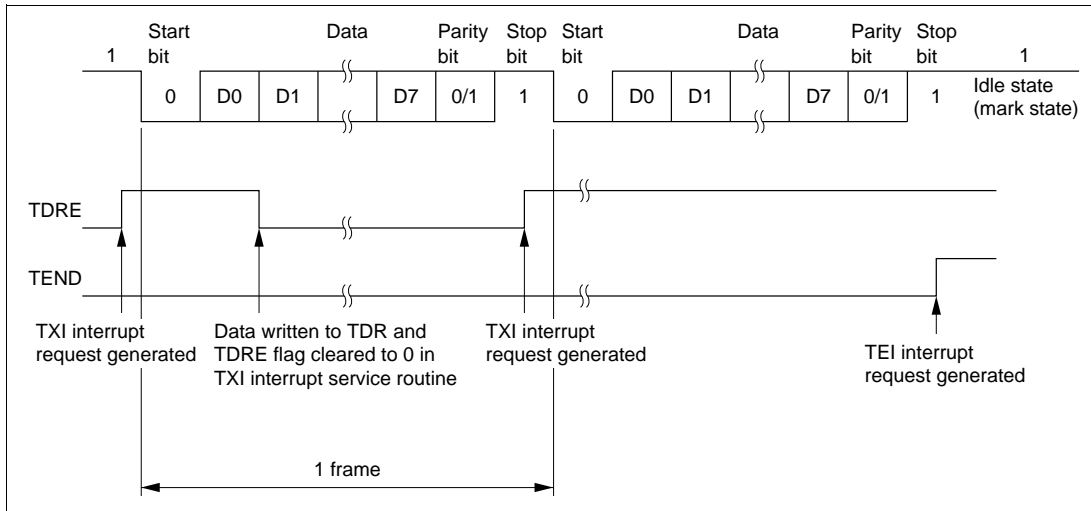
1 is output continuously until the start bit that starts the next transmission is sent.

[3] The SCI checks the TDRE flag at the timing for sending the stop bit.

If the TDRE flag is cleared to 0, the data is transferred from TDR to TSR, the stop bit is sent, and then serial transmission of the next frame is started.

If the TDRE flag is set to 1, the TEND flag in SSR is set to 1, the stop bit is sent, and then the "mark state" is entered in which 1 is output continuously. If the TEIE bit in SCR is set to 1 at this time, a TEI interrupt request is generated.

Figure 16-6 shows an example of the operation for transmission in asynchronous mode.



**Figure 16-6 Example of Operation in Transmission in Asynchronous Mode  
(Example with 8-Bit Data, Parity, One Stop Bit)**

- Serial data reception (asynchronous mode)

Figure 16-7 shows a sample flowchart for serial reception.

The following procedure should be used for serial data reception.

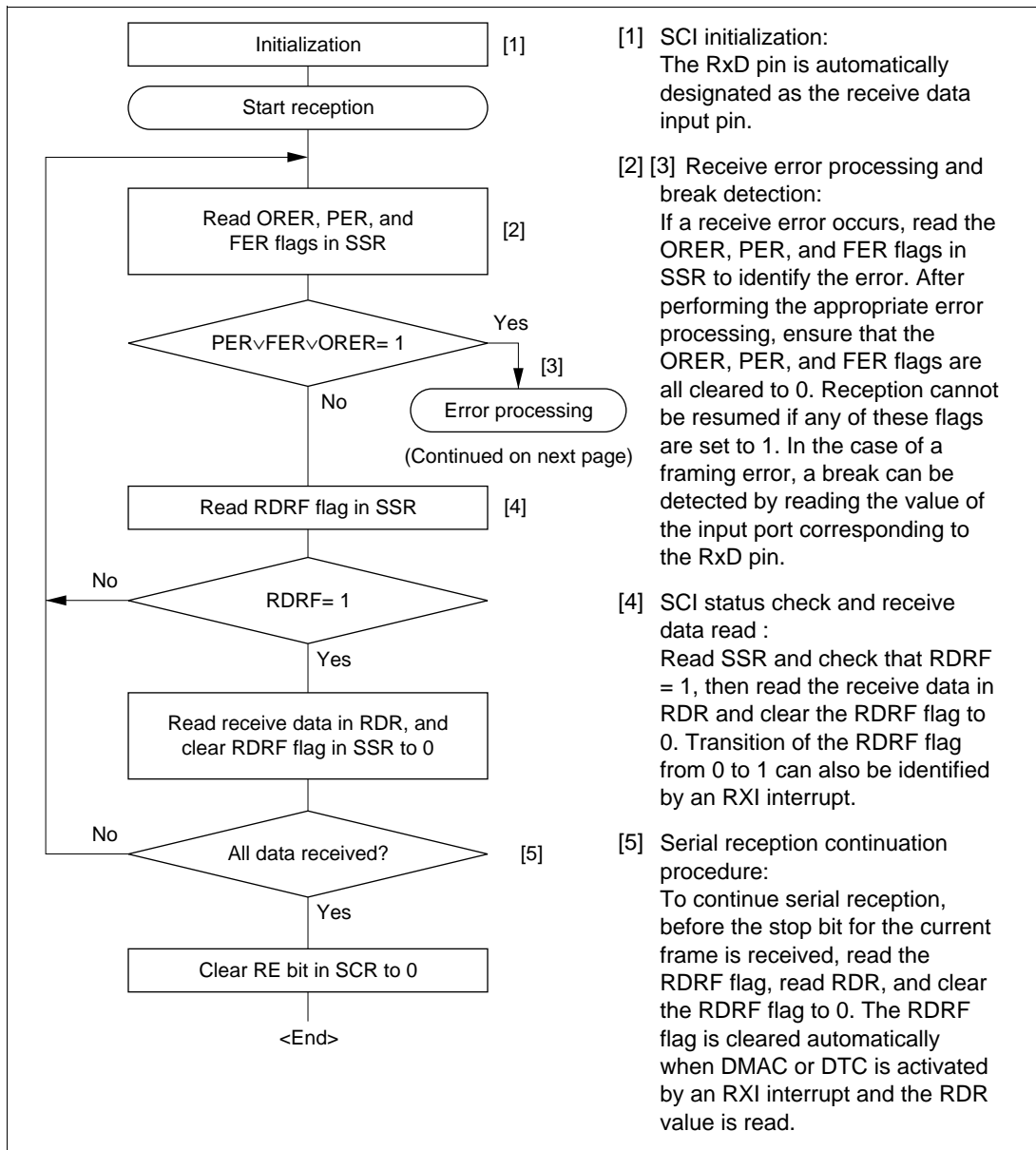


Figure 16-7 Sample Serial Reception Data Flowchart

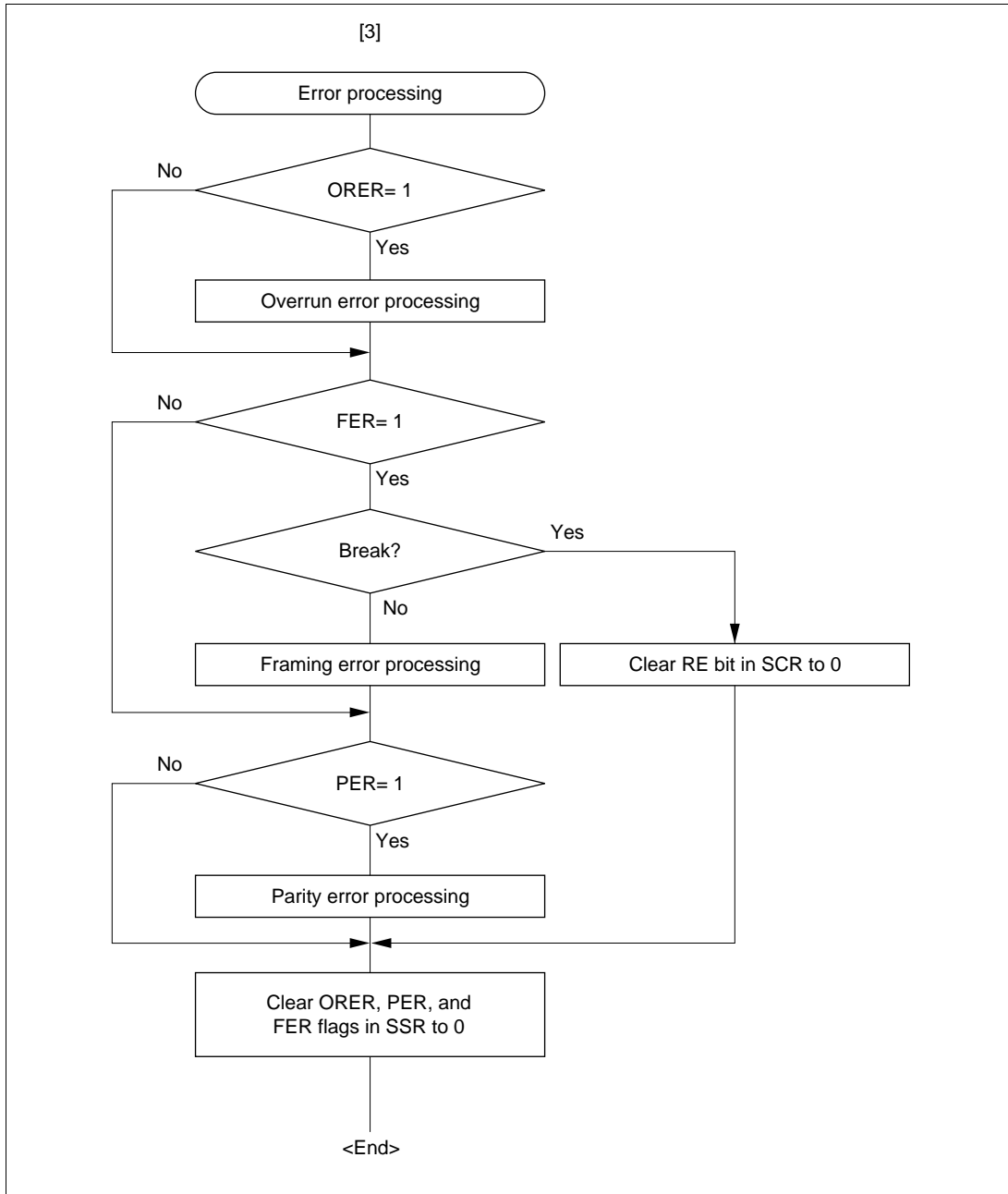


Figure 16-7 Sample Serial Reception Data Flowchart (cont)

In serial reception, the SCI operates as described below.

[1] The SCI monitors the transmission line, and if a 0 stop bit is detected, performs internal synchronization and starts reception.

[2] The received data is stored in RSR in LSB-to-MSB order.

[3] The parity bit and stop bit are received.

After receiving these bits, the SCI carries out the following checks.

[a] Parity check:

The SCI checks whether the number of 1 bits in the receive data agrees with the parity (even or odd) set in the O/E bit in SMR.

[b] Stop bit check:

The SCI checks whether the stop bit is 1.

If there are two stop bits, only the first is checked.

[c] Status check:

The SCI checks whether the RDRF flag is 0, indicating that the receive data can be transferred from RSR to RDR.

If all the above checks are passed, the RDRF flag is set to 1, and the receive data is stored in RDR.

If a receive error\* is detected in the error check, the operation is as shown in table 16-11.

Note: \* Subsequent receive operations cannot be performed when a receive error has occurred.

Also note that the RDRF flag is not set to 1 in reception, and so the error flags must be cleared to 0.

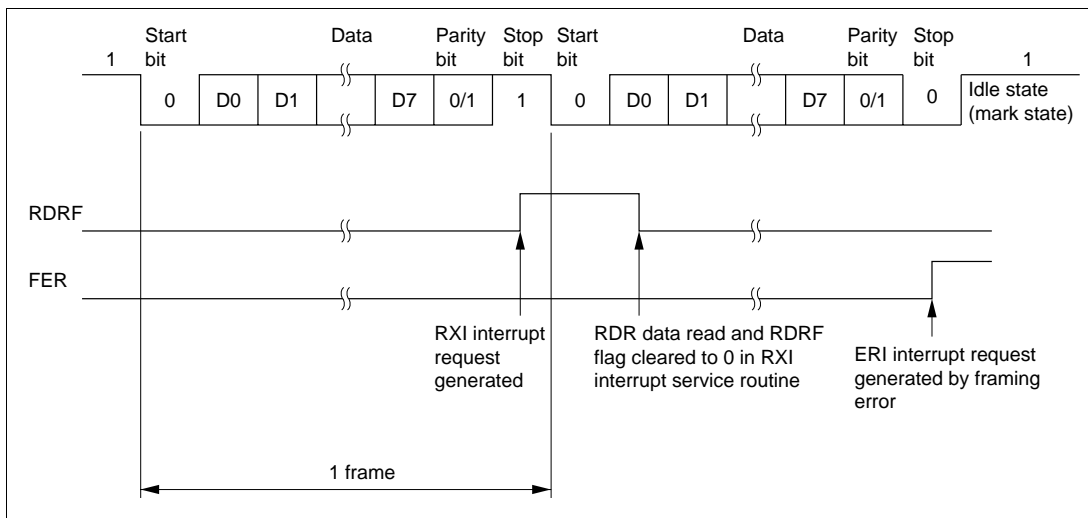
[4] If the RIE bit in SCR is set to 1 when the RDRF flag changes to 1, a receive data full interrupt (RXI) request is generated.

Also, if the RIE bit in SCR is set to 1 when the ORER, PER, or FER flag changes to 1, a receive error interrupt (ERI) request is generated.

**Table 16-11 Receive Errors and Conditions for Occurrence**

Receive Error	Abbreviation	Occurrence Condition	Data Transfer
Overrun error	ORER	When the next data reception is completed while the RDRF flag in SSR is set to 1	Receive data is not transferred from RSR to RDR.
Framing error	FER	When the stop bit is 0	Receive data is transferred from RSR to RDR.
Parity error	PER	When the received data differs from the parity (even or odd) set in SMR	Receive data is transferred from RSR to RDR.

Figure 16-8 shows an example of the operation for reception in asynchronous mode.



**Figure 16-8 Example of SCI Operation in Reception  
(Example with 8-Bit Data, Parity, One Stop Bit)**

### 16.3.3 Multiprocessor Communication Function

The multiprocessor communication function performs serial communication using the multiprocessor format, in which a multiprocessor bit is added to the transfer data, in asynchronous mode. Use of this function enables data transfer to be performed among a number of processors sharing transmission lines.

When multiprocessor communication is carried out, each receiving station is addressed by a unique ID code.

The serial communication cycle consists of two component cycles: an ID transmission cycle which specifies the receiving station, and a data transmission cycle. The multiprocessor bit is used to differentiate between the ID transmission cycle and the data transmission cycle.

The transmitting station first sends the ID of the receiving station with which it wants to perform serial communication as data with a 1 multiprocessor bit added. It then sends transmit data as data with a 0 multiprocessor bit added.

The receiving station skips the data until data with a 1 multiprocessor bit is sent.

When data with a 1 multiprocessor bit is received, the receiving station compares that data with its own ID. The station whose ID matches then receives the data sent next. Stations whose ID does not match continue to skip the data until data with a 1 multiprocessor bit is again received. In this way, data communication is carried out among a number of processors.

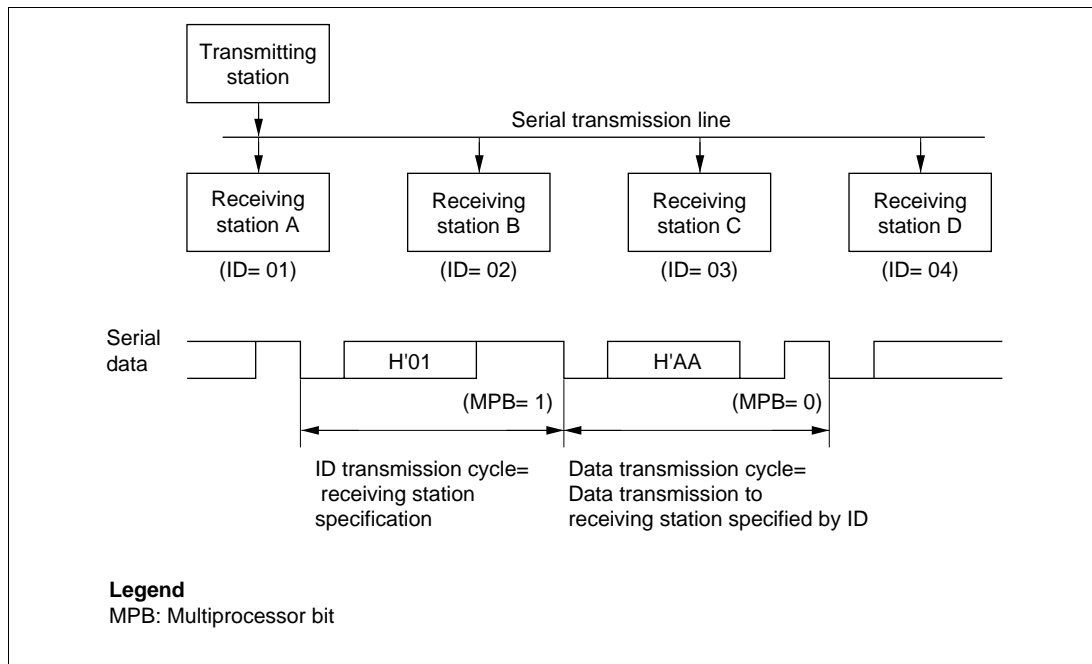
Figure 16-9 shows an example of inter-processor communication using the multiprocessor format.

**Data Transfer Format:** There are four data transfer formats.

When the multiprocessor format is specified, the parity bit specification is invalid.

For details, see table 16-10.

**Clock:** See the section on asynchronous mode.



**Figure 16-9 Example of Inter-Processor Communication Using Multiprocessor Format (Transmission of Data H'AA to Receiving Station A)**

**Data Transfer Operations:**

- Multiprocessor serial data transmission

Figure 16-10 shows a sample flowchart for multiprocessor serial data transmission.

The following procedure should be used for multiprocessor serial data transmission.



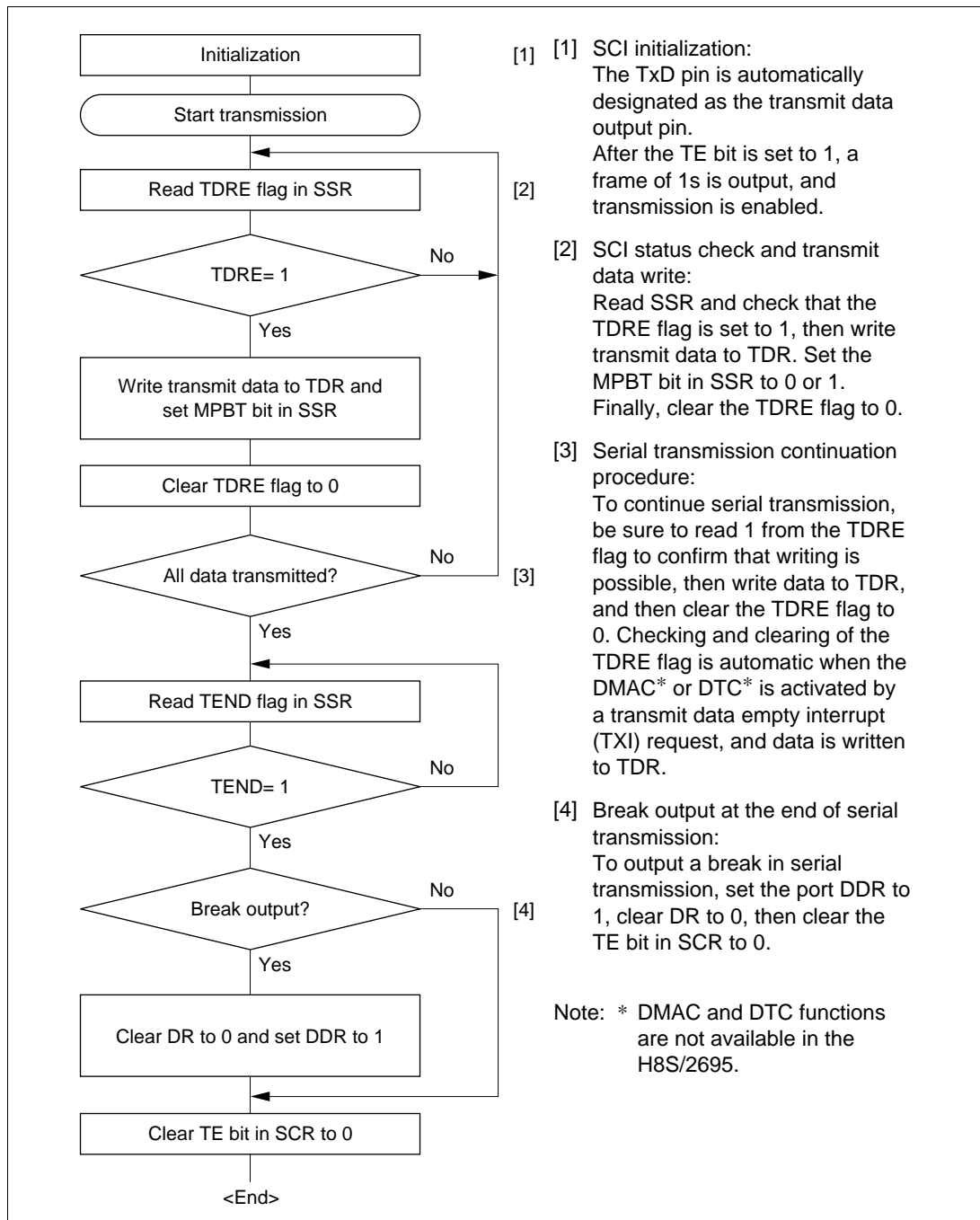
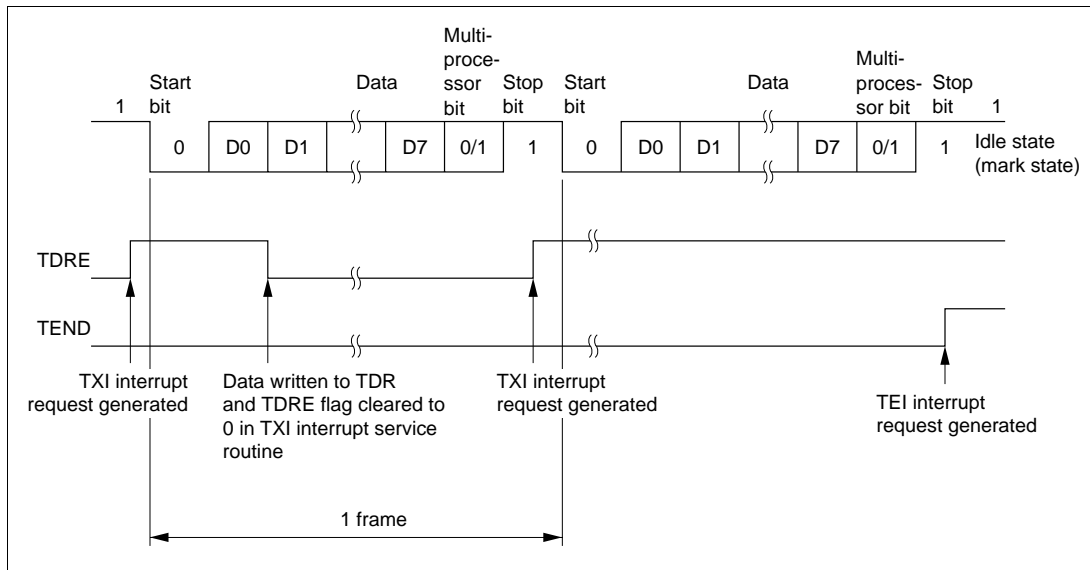


Figure 16-10 Sample Multiprocessor Serial Transmission Flowchart

In serial transmission, the SCI operates as described below.

- [1] The SCI monitors the TDRE flag in SSR, and if it is 0, recognizes that data has been written to TDR, and transfers the data from TDR to TSR.
- [2] After transferring data from TDR to TSR, the SCI sets the TDRE flag to 1 and starts transmission.  
If the TIE bit in SCR is set to 1 at this time, a transmit data empty interrupt (TXI) is generated. The serial transmit data is sent from the TxD pin in the following order.
  - [a] Start bit:  
One 0-bit is output.
  - [b] Transmit data:  
8-bit or 7-bit data is output in LSB-first order.
  - [c] Multiprocessor bit  
One multiprocessor bit (MPBT value) is output.
  - [d] Stop bit(s):  
One or two 1-bits (stop bits) are output.
  - [e] Mark state:  
1 is output continuously until the start bit that starts the next transmission is sent.
- [3] The SCI checks the TDRE flag at the timing for sending the stop bit.  
If the TDRE flag is cleared to 0, data is transferred from TDR to TSR, the stop bit is sent, and then serial transmission of the next frame is started.  
If the TDRE flag is set to 1, the TEND flag in SSR is set to 1, the stop bit is sent, and then the mark state is entered in which 1 is output continuously. If the TEIE bit in SCR is set to 1 at this time, a transmission end interrupt (TEI) request is generated.

Figure 16-11 shows an example of SCI operation for transmission using the multiprocessor format.



**Figure 16-11 Example of SCI Operation in Transmission  
(Example with 8-Bit Data, Multiprocessor Bit, One Stop Bit)**

- Multiprocessor serial data reception

Figure 16-12 shows a sample flowchart for multiprocessor serial reception.

The following procedure should be used for multiprocessor serial data reception.

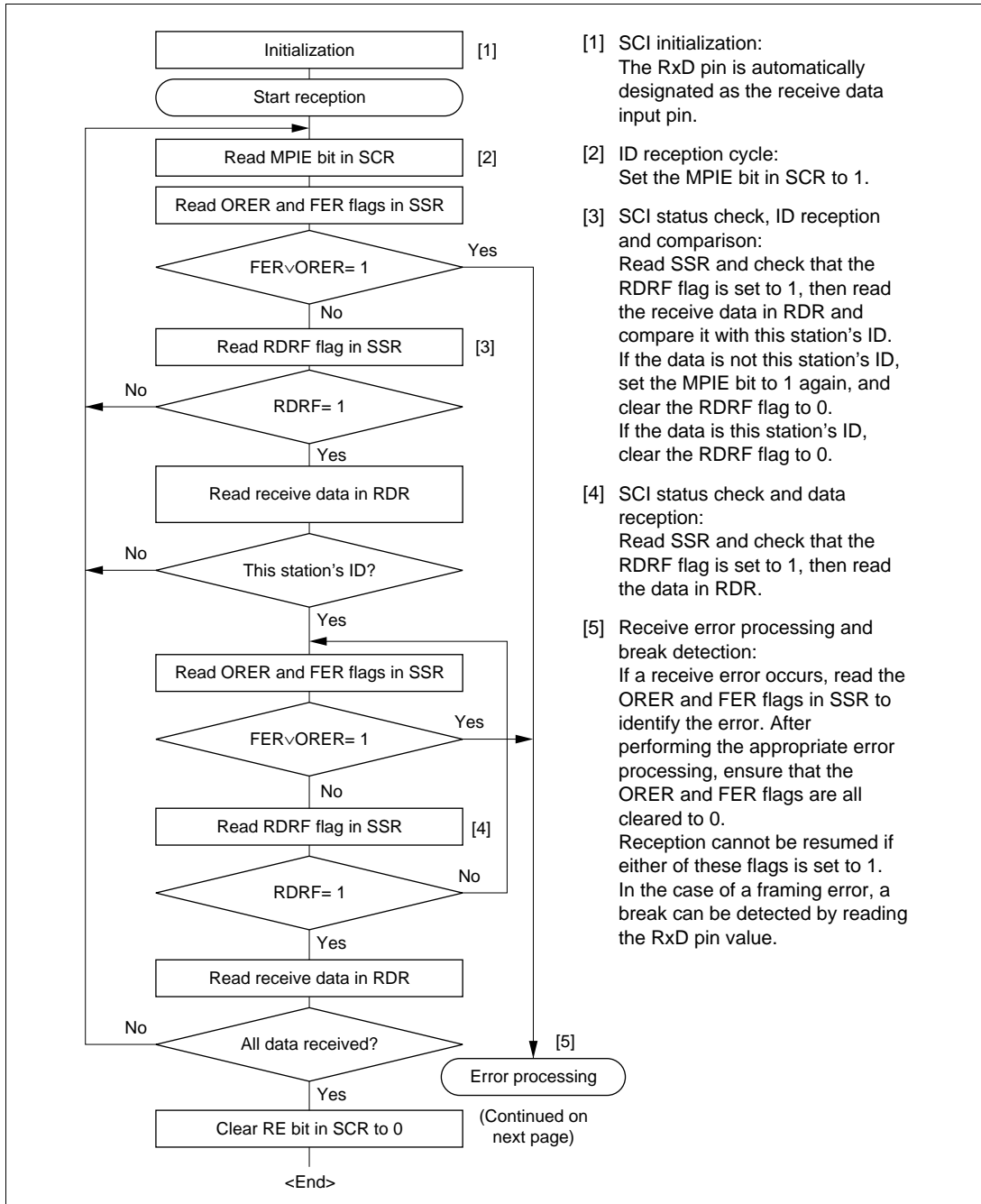
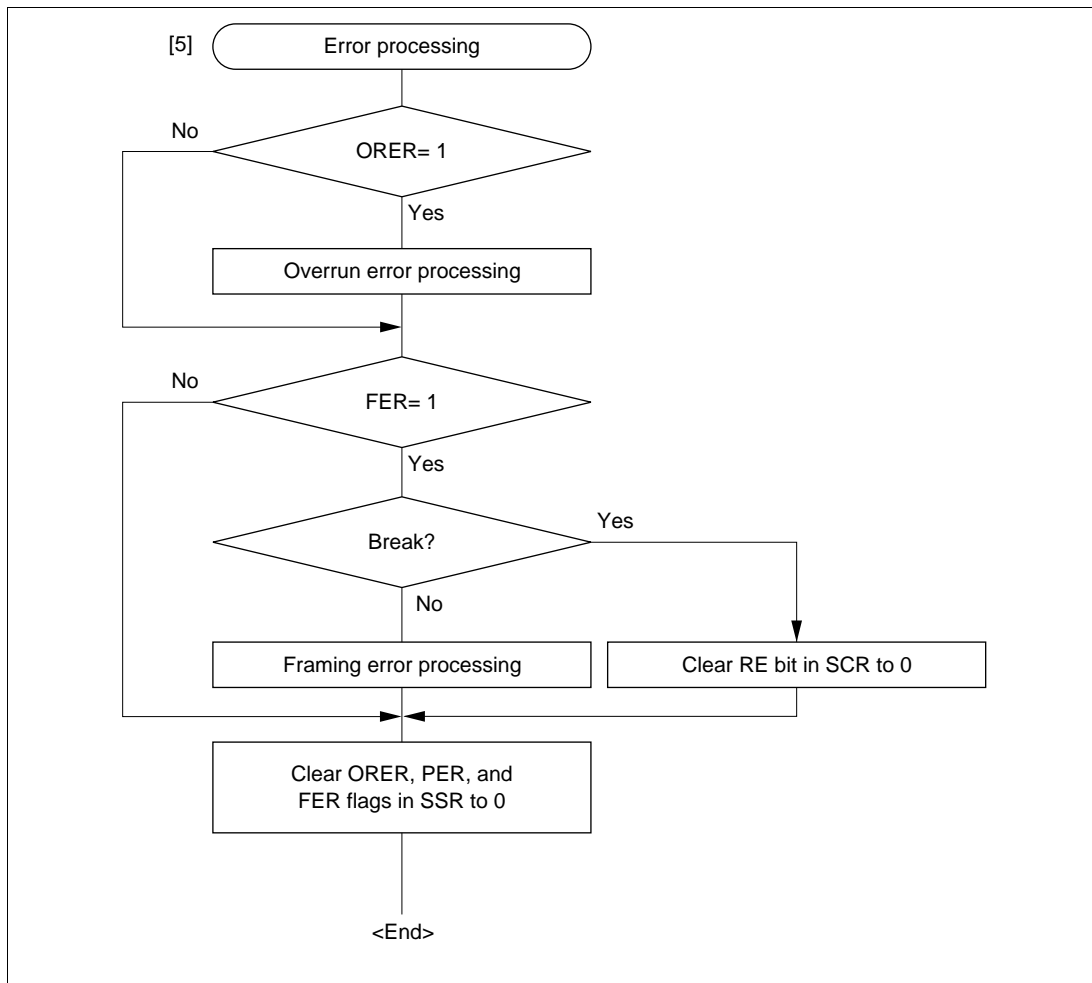
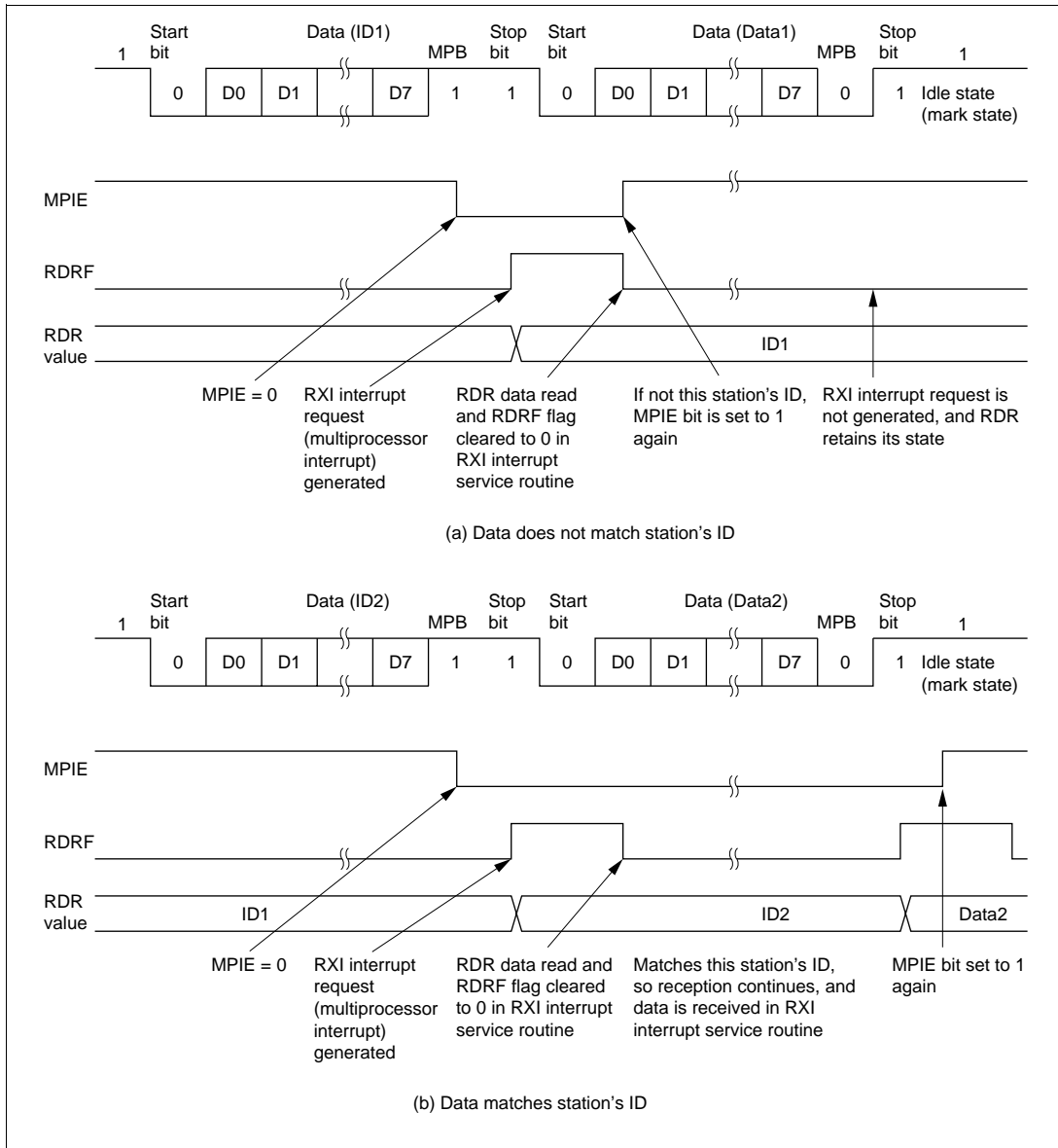


Figure 16-12 Sample Multiprocessor Serial Reception Flowchart



**Figure 16-12 Sample Multiprocessor Serial Reception Flowchart (cont)**

Figure 16-13 shows an example of SCI operation for multiprocessor format reception.



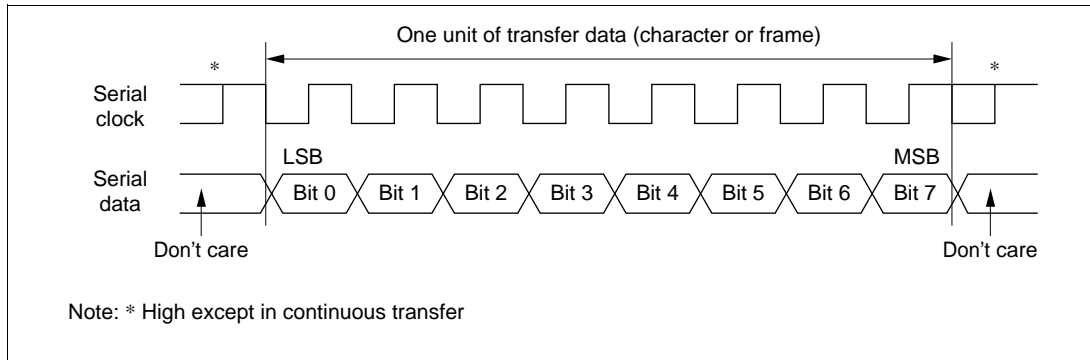
**Figure 16-13 Example of SCI Operation in Reception  
(Example with 8-Bit Data, Multiprocessor Bit, One Stop Bit)**

### 16.3.4 Operation in Clocked Synchronous Mode

In clocked synchronous mode, data is transmitted or received in synchronization with clock pulses, making it suitable for high-speed serial communication.

Inside the SCI, the transmitter and receiver are independent units, enabling full-duplex communication by use of a common clock. Both the transmitter and the receiver also have a double-buffered structure, so that data can be read or written during transmission or reception, enabling continuous data transfer.

Figure 16-14 shows the general format for clocked synchronous serial communication.



**Figure 16-14 Data Format in Synchronous Communication**

In clocked synchronous serial communication, data on the transmission line is output from one falling edge of the serial clock to the next. Data confirmation is guaranteed at the rising edge of the serial clock.

In clocked serial communication, one character consists of data output starting with the LSB and ending with the MSB. After the MSB is output, the transmission line holds the MSB state.

In clocked synchronous mode, the SCI receives data in synchronization with the rising edge of the serial clock.

**Data Transfer Format:** A fixed 8-bit data format is used.

No parity or multiprocessor bits are added.

**Clock:** Either an internal clock generated by the on-chip baud rate generator or an external serial clock input at the SCK pin can be selected, according to the setting of the  $C/\bar{A}$  bit in SMR and the CKE1 and CKE0 bits in SCR. For details of SCI clock source selection, see table 16-9.

When the SCI is operated on an internal clock, the serial clock is output from the SCK pin.

Eight serial clock pulses are output in the transfer of one character, and when no transfer is performed the clock is fixed high. When only receive operations are performed, however, the serial clock is output until an overrun error occurs or the RE bit is cleared to 0. If you want to perform receive operations in units of one character, you should select an external clock as the clock source.

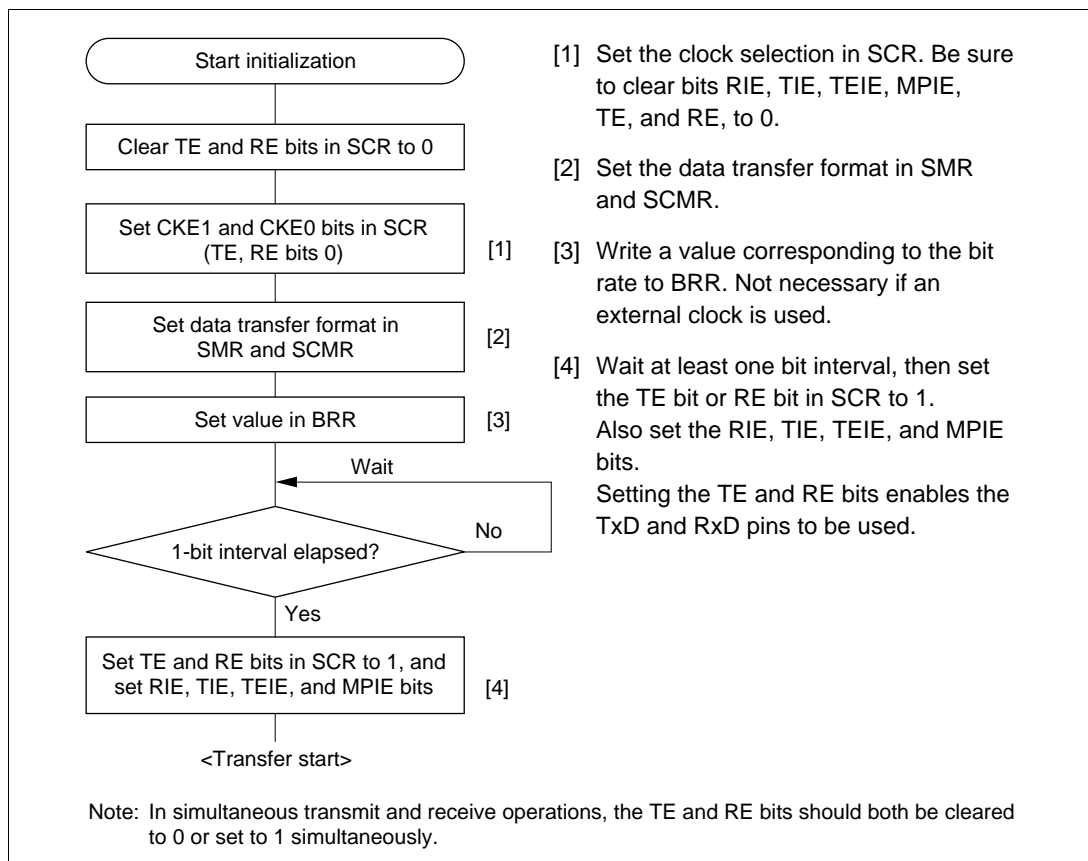
### Data Transfer Operations:

- SCI initialization (clocked synchronous mode)

Before transmitting and receiving data, you should first clear the TE and RE bits in SCR to 0, then initialize the SCI as described below.

When the operating mode, transfer format, etc., is changed, the TE and RE bits must be cleared to 0 before making the change using the following procedure. When the TE bit is cleared to 0, the TDRE flag is set to 1 and TSR is initialized. Note that clearing the RE bit to 0 does not change the contents of the RDRF, PER, FER, and ORER flags, or the contents of RDR.

Figure 16-15 shows a sample SCI initialization flowchart.



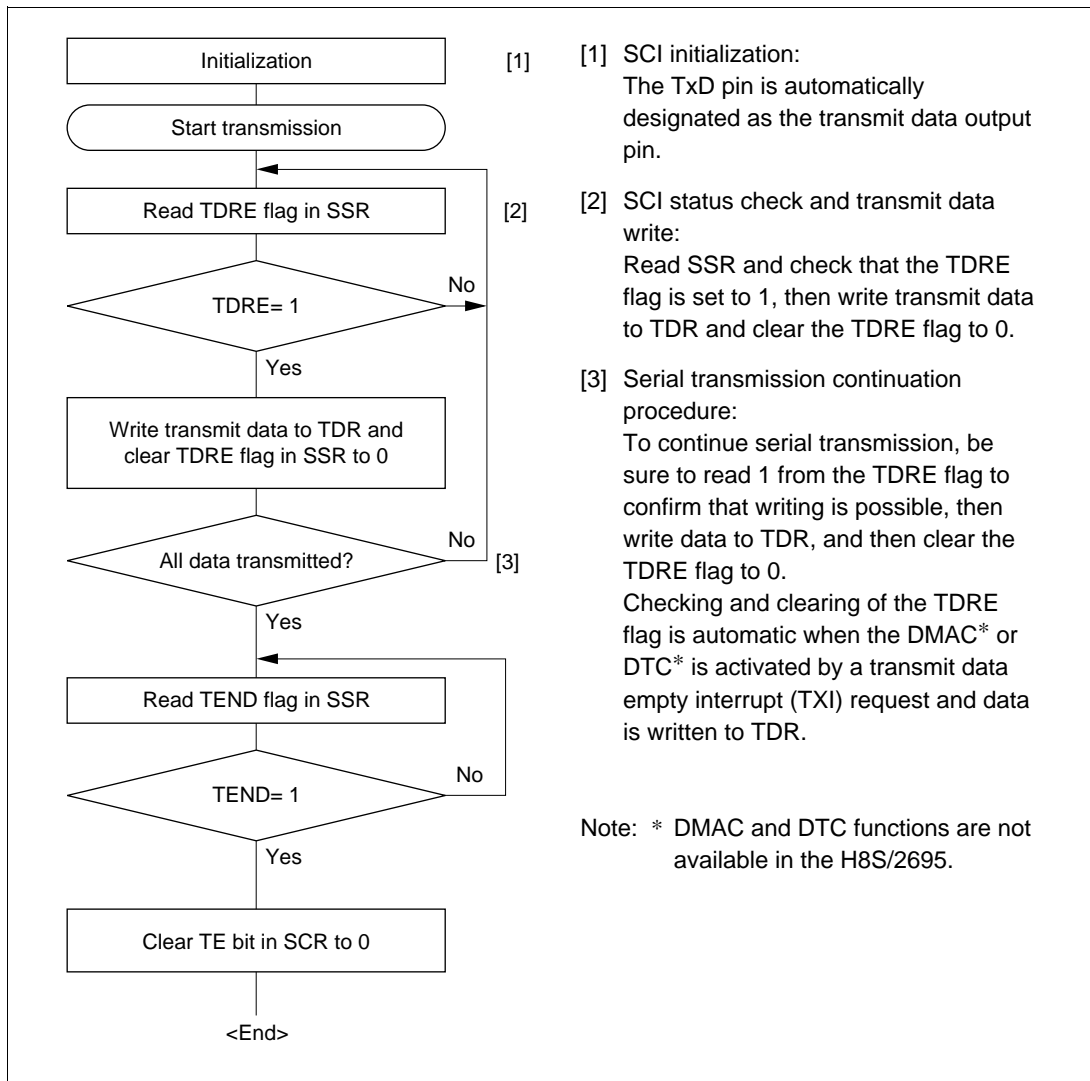
**Figure 16-15 Sample SCI Initialization Flowchart**



- Serial data transmission (clocked synchronous mode)

Figure 16-16 shows a sample flowchart for serial transmission.

The following procedure should be used for serial data transmission.



**Figure 16-16 Sample Serial Transmission Flowchart**

In serial transmission, the SCI operates as described below.

[1] The SCI monitors the TDRE flag in SSR, and if it is 0, recognizes that data has been written to TDR, and transfers the data from TDR to TSR.

[2] After transferring data from TDR to TSR, the SCI sets the TDRE flag to 1 and starts transmission. If the TIE bit in SCR is set to 1 at this time, a transmit data empty interrupt (TXI) is generated.

When clock output mode has been set, the SCI outputs 8 serial clock pulses. When use of an external clock has been specified, data is output synchronized with the input clock.

The serial transmit data is sent from the TxD pin starting with the LSB (bit 0) and ending with the MSB (bit 7).

[3] The SCI checks the TDRE flag at the timing for sending the MSB (bit 7).

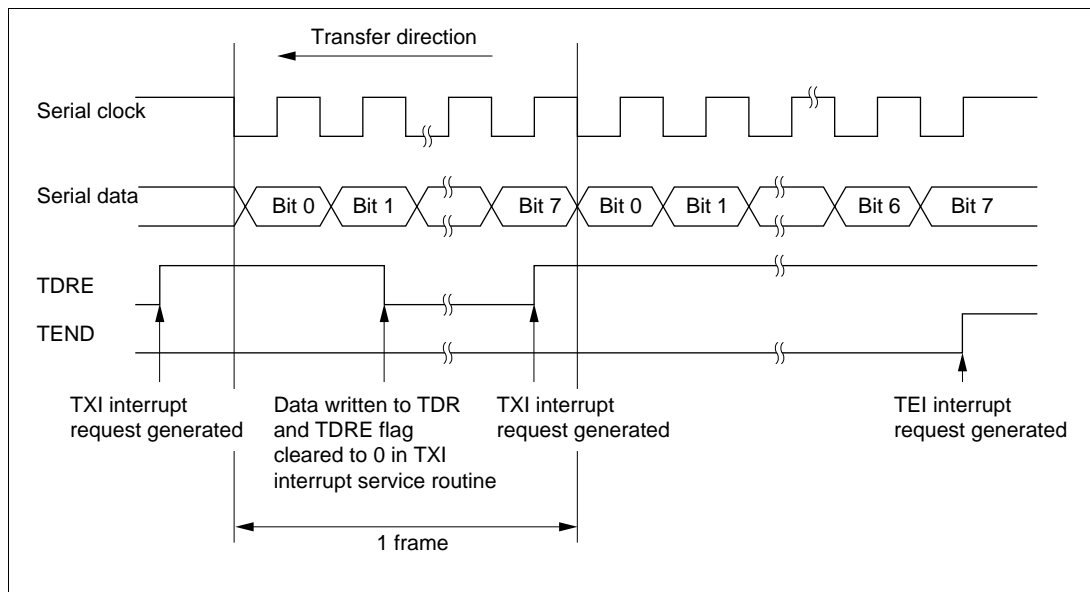
If the TDRE flag is cleared to 0, data is transferred from TDR to TSR, and serial transmission of the next frame is started.

If the TDRE flag is set to 1, the TEND flag in SSR is set to 1, the MSB (bit 7) is sent, and the TxD pin maintains its state.

If the TEIE bit in SCR is set to 1 at this time, a TEI interrupt request is generated.

[4] After completion of serial transmission, the SCK pin is fixed high.

Figure 16-17 shows an example of SCI operation in transmission.



**Figure 16-17 Example of SCI Operation in Transmission**

- Serial data reception (clocked synchronous mode)

Figure 16-18 shows a sample flowchart for serial reception.

The following procedure should be used for serial data reception.

When changing the operating mode from asynchronous to clocked synchronous, be sure to check that the ORER, PER, and FER flags are all cleared to 0.

The RDRF flag will not be set if the FER or PER flag is set to 1, and neither transmit nor receive operations will be possible.

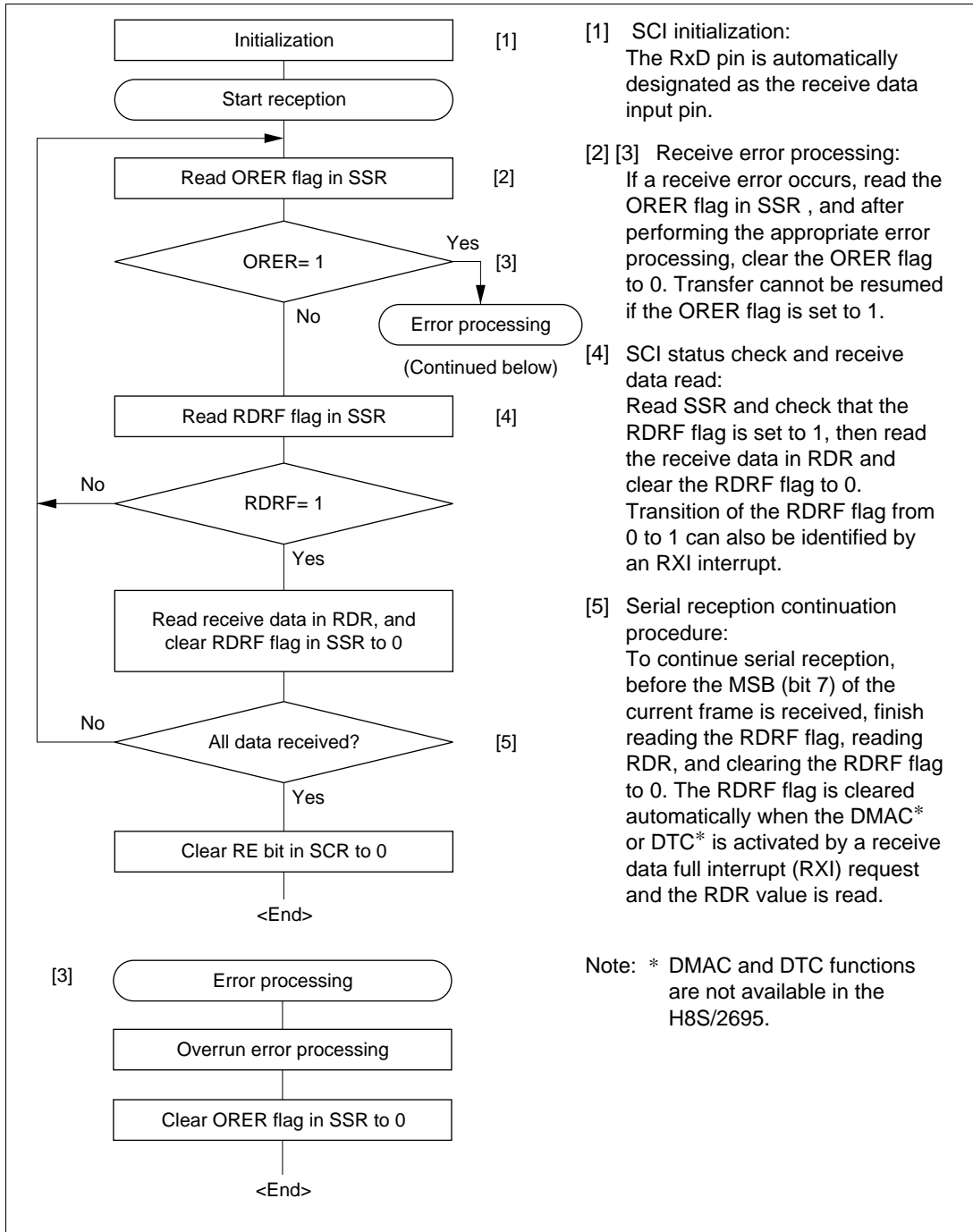


Figure 16-18 Sample Serial Reception Flowchart

In serial reception, the SCI operates as described below.

[1] The SCI performs internal initialization in synchronization with serial clock input or output.

[2] The received data is stored in RSR in LSB-to-MSB order.

After reception, the SCI checks whether the RDRF flag is 0 and the receive data can be transferred from RSR to RDR.

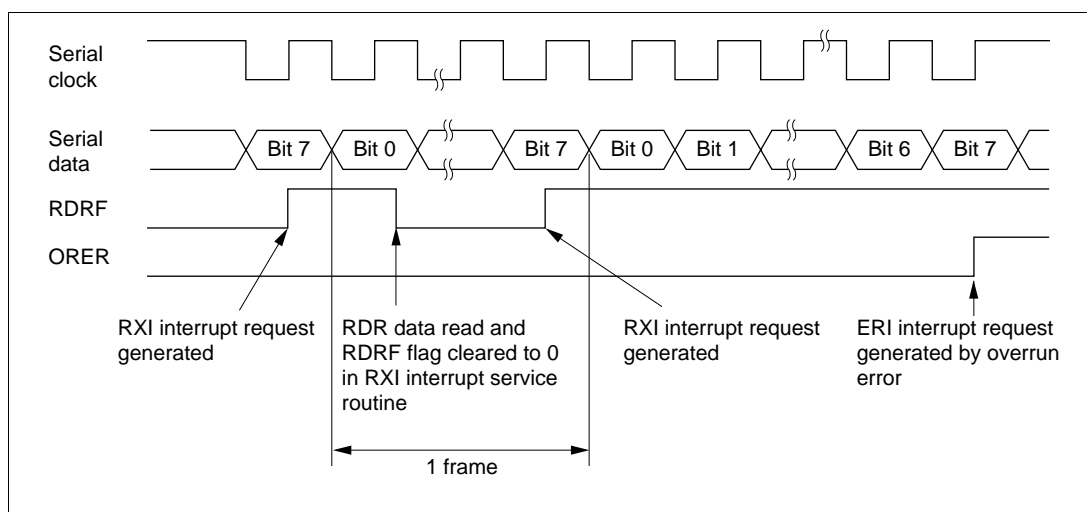
If this check is passed, the RDRF flag is set to 1, and the receive data is stored in RDR. If a receive error is detected in the error check, the operation is as shown in table 16-11.

Neither transmit nor receive operations can be performed subsequently when a receive error has been found in the error check.

[3] If the RIE bit in SCR is set to 1 when the RDRF flag changes to 1, a receive data full interrupt (RXI) request is generated.

Also, if the RIE bit in SCR is set to 1 when the ORER flag changes to 1, a receive error interrupt (ERI) request is generated.

Figure 16-19 shows an example of SCI operation in reception.

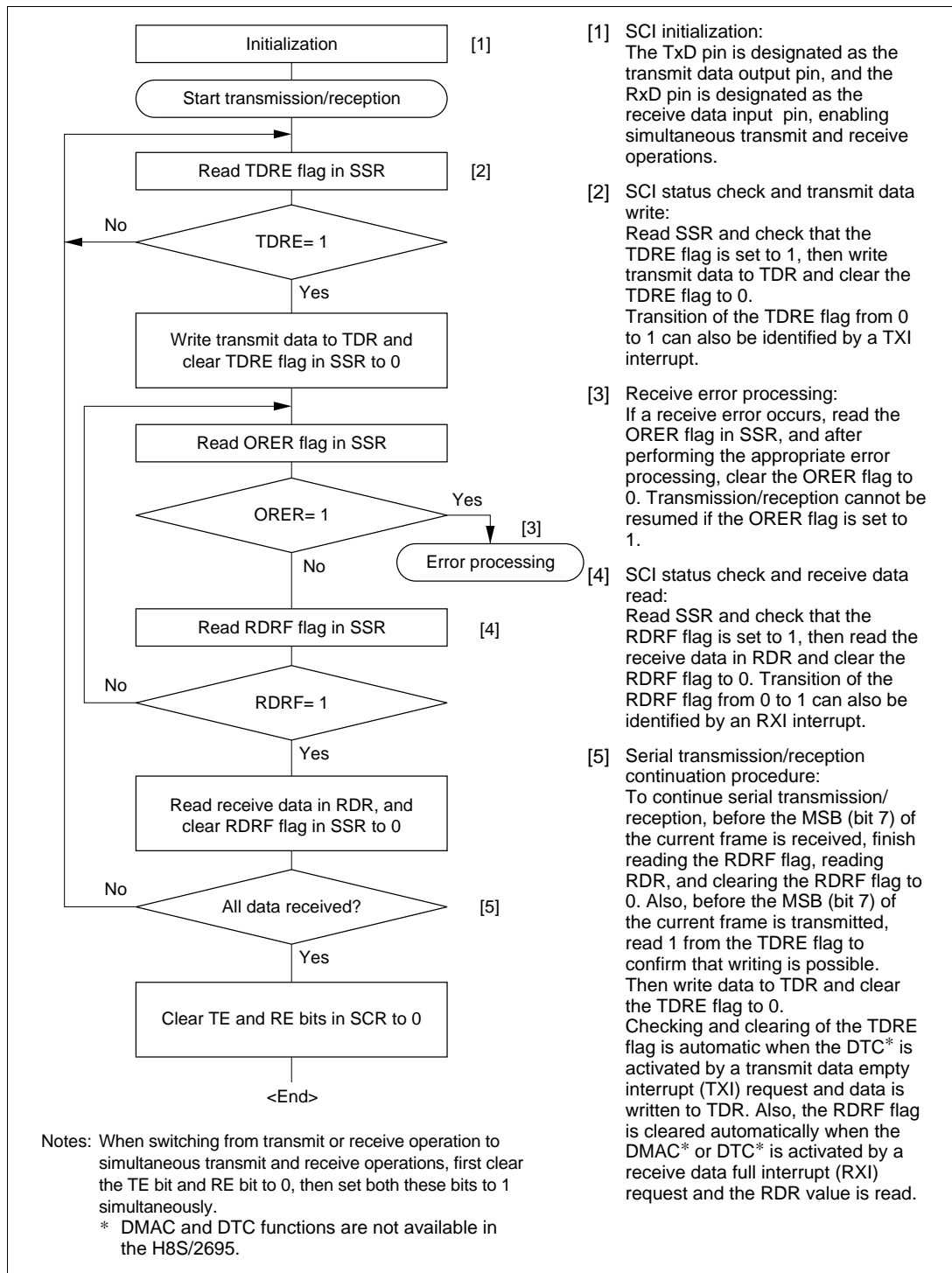


**Figure 16-19 Example of SCI Operation in Reception**

- Simultaneous serial data transmission and reception (clocked synchronous mode)

Figure 16-20 shows a sample flowchart for simultaneous serial transmit and receive operations.

The following procedure should be used for simultaneous serial data transmit and receive operations.



**Figure 16-20 Sample Flowchart of Simultaneous Serial Transmit and Receive Operations**

### 16.3.5 IrDA Operation

Figure 16-21 is a block diagram of the IrDA.

When the IrE bit of IrCR is set to enable the IrDA function, the TxD0/RxD0 signals of SCI channel 0 are encoded and decoded with waveforms conforming to the IrDA standard version 1.0 (IrTxD/IrRxD pins). Connecting these to an infrared transmitter/receiver allows the realization of infrared transmission and reception conforming to an IrDA standard version 1.0 system.

In an IrDA standard version 1.0 system, communication is initiated at a transfer rate of 9600 bps. The rate is subsequently varied as required. The IrDA interface of this LSI does not have an internal function for automatically varying the transfer rate. The transfer rate must be varied using software.

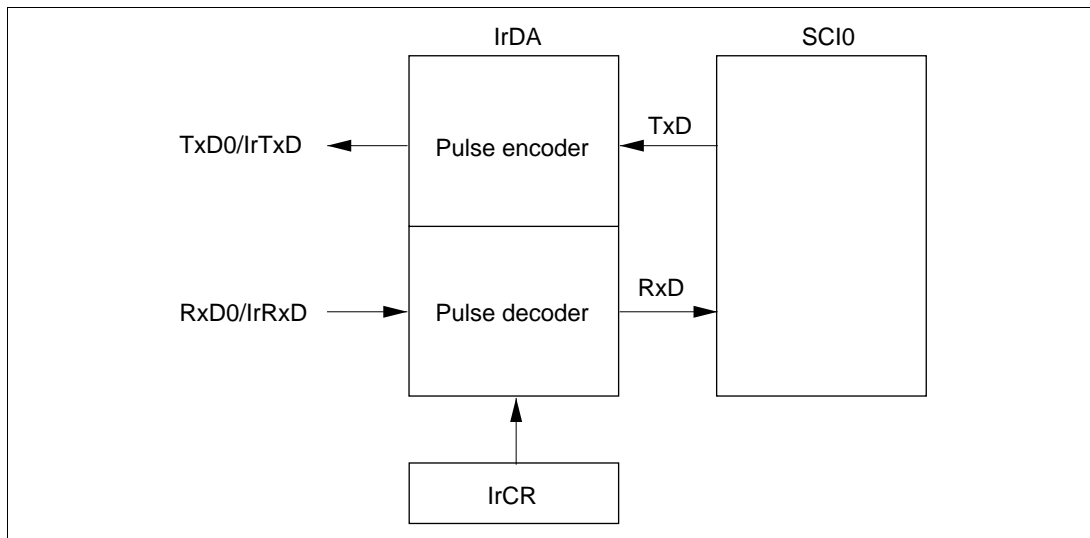


Figure 16-21 IrDA Block Diagram

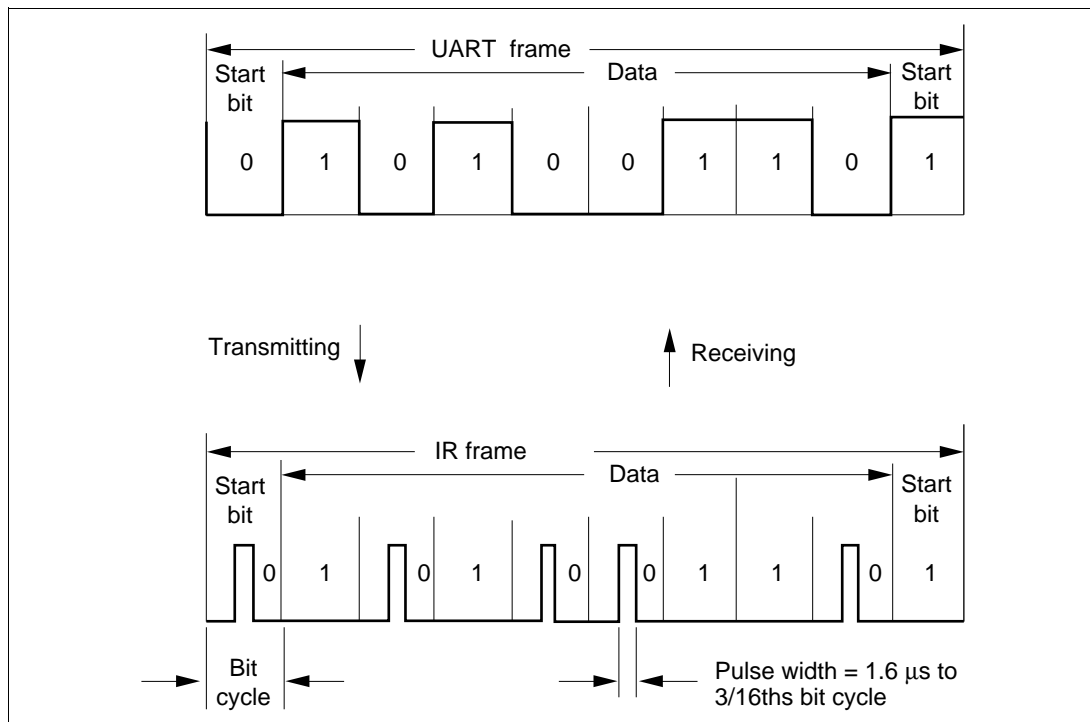
#### (1) Transmission

When transmitting, the signal (UART frame) output from the SCI is converted by the IrDA interface into an IR frame (see figure 16-22).

When the value of the serial data is “0”, a High pulse that has 3/16ths the width of the bit rate (the duration of 1 bit width) is output (default). Note that the High pulse can also be changed by altering the settings of IrCR IrCKS2 to IrCKS0.

As per the standard, the High pulse width is a minimum of 1.41  $\mu$ s, the maximum is  $(3/16 + 2.5\%) \times$  bit rate, or  $(3/16 \times$  bit rate) + 1.08  $\mu$ s. With a 20MHz system clock  $\phi$ , the minimum High pulse width can be set to 1.6  $\mu$ s, which is greater than the 1.41  $\mu$ s required by the standard.

When the value of the serial data is “1”, no pulse is output.



**Figure 16-22 IrDA Transmit and Receive Operations**

## (2) Receiving

When receiving, the IR frame data is converted into UART frames by the IrDA interface and input to the SCI.

When a High pulse is detected, “0” is output. If there is no pulse for the duration of 1 bit, “1” is output. Pulses of less than the minimum pulse width of 1.41 μs are also recognized as “0” data.

## (3) Selecting High Pulse Width

Table 16-12 shows the settings of IrCKS2 to IrCKS0 (for the minimum pulse width), at various LSI operating frequencies, and various bit rates to set the pulse width when transmitting with a pulse width less than 3/16ths of the bit rate.



**Table 16-12 Setting Bits IrCKS2 to IrCKS0**

Operating Frequency (MHz)	Bit Rate (bps) (Upper Row) / Bit Cycle × 3/16 (μs) (Lower Row)					
	2400	9600	19200	38400	57600	115200
2	78.13	19.53	9.77	4.88	3.26	1.63
2.097152	010	010	010	010	010	—
2.4576	010	010	010	010	010	—
3	011	011	011	011	011	—
3.6864	011	011	011	011	011	011
4.9152	011	011	011	011	011	011
5	011	011	011	011	011	011
6	100	100	100	100	100	100
6.144	100	100	100	100	100	100
7.3728	100	100	100	100	100	100
8	100	100	100	100	100	100
9.8304	100	100	100	100	100	100
10	100	100	100	100	100	100
12	101	101	101	101	101	101
12.288	101	101	101	101	101	101
14	101	101	101	101	101	101
14.7456	101	101	101	101	101	101
16	101	101	101	101	101	101
16.9344	101	101	101	101	101	101
17.2032	101	101	101	101	101	101
18	101	101	101	101	101	101
19.6608	101	101	101	101	101	101
20	101	101	101	101	101	101
25	110	110	110	110	110	110

**Legend**

—: SCI cannot be set to this bit rate.

## 16.4 SCI Interrupts

The SCI has four interrupt sources: the transmit-end interrupt (TEI) request, receive-error interrupt (ERI) request, receive-data-full interrupt (RXI) request, and transmit-data-empty interrupt (TXI) request. Table 16-13 shows the interrupt sources and their relative priorities. Individual interrupt sources can be enabled or disabled with the TIE, RIE, and TEIE bits in the SCR. Each kind of interrupt request is sent to the interrupt controller independently.

When the TDRE flag in SSR is set to 1, a TXI interrupt request is generated. When the TEND flag in SSR is set to 1, a TEI interrupt request is generated. A TXI interrupt can activate the DMAC\* or DTC\* to perform data transfer. The TDRE flag is cleared to 0 automatically when data transfer is performed by the DMAC\* or DTC\*. The DMAC\* or DTC\* cannot be activated by a TEI interrupt request.

When the RDRF flag in SSR is set to 1, an RXI interrupt request is generated. When the ORER, PER, or FER flag in SSR is set to 1, an ERI interrupt request is generated. An RXI interrupt can activate the DMAC\* or DTC\* to perform data transfer. The RDRF flag is cleared to 0 automatically when data transfer is performed by the DMAC\* or DTC\*. The DMAC\* or DTC\* cannot be activated by an ERI interrupt request.

Note that the DMAC\* cannot be activated by interrupts of SCI channels 2 to 4.

Note: \* DMAC and DTC functions are not available in the H8S/2695.

**Table 16-13 SCI Interrupt Sources**

Channel	Interrupt Source	Description	DTC*1 Activation	DMAC*1 Activation	Priority*2
0	ERI	Interrupt due to receive error (ORER, FER, or PER)	Not possible	Not possible	High ↑
	RXI	Interrupt due to receive data full state (RDRF)	Possible	Possible	
	TXI	Interrupt due to transmit data empty state (TDRE)	Possible	Possible	
	TEI	Interrupt due to transmission end (TEND)	Not possible	Not possible	
1	ERI	Interrupt due to receive error (ORER, FER, or PER)	Not possible	Not possible	↑
	RXI	Interrupt due to receive data full state (RDRF)	Possible	Possible	
	TXI	Interrupt due to transmit data empty state (TDRE)	Possible	Possible	
	TEI	Interrupt due to transmission end (TEND)	Not possible	Not possible	
2	ERI	Interrupt due to receive error (ORER, FER, or PER)	Not possible	Not possible	↑
	RXI	Interrupt due to receive data full state (RDRF)	Possible	Not possible	
	TXI	Interrupt due to transmit data empty state (TDRE)	Possible	Not possible	
	TEI	Interrupt due to transmission end (TEND)	Not possible	Not possible	
3	ERI	Interrupt due to receive error (ORER, FER, or PER)	Not possible	Not possible	↑
	RXI	Interrupt due to receive data full state (RDRF)	Possible	Not possible	
	TXI	Interrupt due to transmit data empty state (TDRE)	Possible	Not possible	
	TEI	Interrupt due to transmission end (TEND)	Not possible	Not possible	
4	ERI	Interrupt due to receive error (ORER, FER, or PER)	Not possible	Not possible	↑ Low
	RXI	Interrupt due to receive data full state (RDRF)	Possible	Not possible	
	TXI	Interrupt due to transmit data empty state (TDRE)	Possible	Not possible	
	TEI	Interrupt due to transmission end (TEND)	Not possible	Not possible	

Notes: \*1 DMAC and DTC functions are not available in the H8S/2695.

\*2 This table shows the initial state immediately after a reset. Relative priorities among channels can be changed by means of the interrupt controller.

A TEI interrupt is requested when the TEND flag is set to 1 while the TEIE bit is set to 1. The TEND flag is cleared at the same time as the TDRE flag. Consequently, if a TEI interrupt and a TXI interrupt are requested simultaneously, the TXI interrupt may have priority for acceptance, with the result that the TDRE and TEND flags are cleared. Note that the TEI interrupt will not be accepted in this case.

## 16.5 Usage Notes

The following points should be noted when using the SCI.

### Relation between Writes to TDR and the TDRE Flag

The TDRE flag in SSR is a status flag that indicates that transmit data has been transferred from TDR to TSR. When the SCI transfers data from TDR to TSR, the TDRE flag is set to 1.

Data can be written to TDR regardless of the state of the TDRE flag. However, if new data is written to TDR when the TDRE flag is cleared to 0, the data stored in TDR will be lost since it has not yet been transferred to TSR. It is therefore essential to check that the TDRE flag is set to 1 before writing transmit data to TDR.

### Operation when Multiple Receive Errors Occur Simultaneously

If a number of receive errors occur at the same time, the state of the status flags in SSR is as shown in table 16-14. If there is an overrun error, data is not transferred from RSR to RDR, and the receive data is lost.

**Table 16-14 State of SSR Status Flags and Transfer of Receive Data**

RDRF	SSR Status Flags			Receive Data Transfer	Receive Error Status
	ORER	FER	PER	RSR to RDR	
1	1	0	0	X	Overrun error
0	0	1	0	○	Framing error
0	0	0	1	○	Parity error
1	1	1	0	X	Overrun error + framing error
1	1	0	1	X	Overrun error + parity error
0	0	1	1	○	Framing error + parity error
1	1	1	1	X	Overrun error + framing error + parity error

Notes: ○: Receive data is transferred from RSR to RDR.

X: Receive data is not transferred from RSR to RDR.

**Break Detection and Processing (Asynchronous Mode Only):** When framing error (FER) detection is performed, a break can be detected by reading the RxD pin value directly. In a break, the input from the RxD pin becomes all 0s, and so the FER flag is set, and the parity error flag (PER) may also be set.

Note that, since the SCI continues the receive operation after receiving a break, even if the FER flag is cleared to 0, it will be set to 1 again.

**Sending a Break (Asynchronous Mode Only):** The TxD pin has a dual function as an I/O port whose direction (input or output) is determined by DR and DDR. This can be used to send a break.

Between serial transmission initialization and setting of the TE bit to 1, the mark state is replaced by the value of DR (the pin does not function as the TxD pin until the TE bit is set to 1). Consequently, DDR and DR for the port corresponding to the TxD pin are first set to 1.

To send a break during serial transmission, first clear DR to 0, then clear the TE bit to 0.

When the TE bit is cleared to 0, the transmitter is initialized regardless of the current transmission state, the TxD pin becomes an I/O port, and 0 is output from the TxD pin.

**Receive Error Flags and Transmit Operations (Clocked Synchronous Mode Only):**

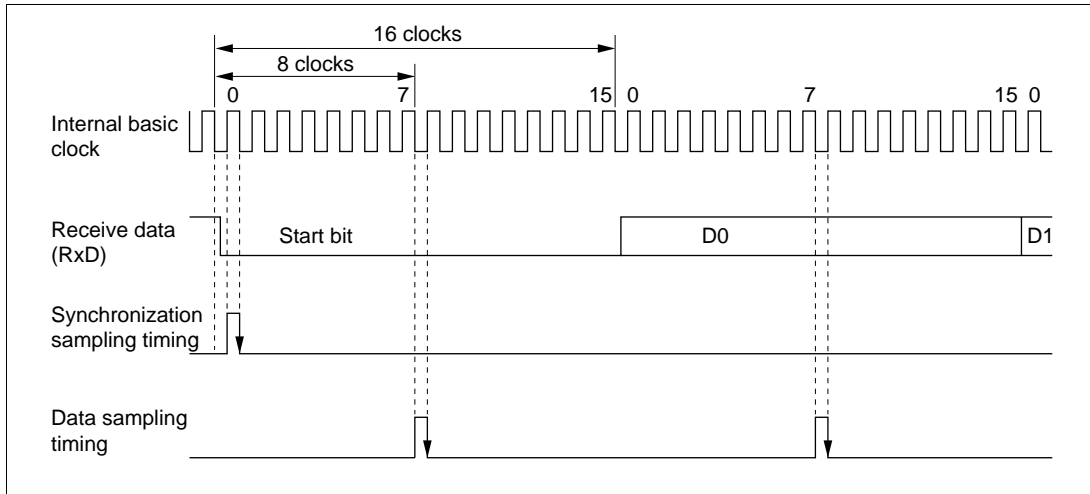
Transmission cannot be started when a receive error flag (ORER, PER, or FER) is set to 1, even if the TDRE flag is cleared to 0. Be sure to clear the receive error flags to 0 before starting transmission.

Note also that receive error flags cannot be cleared to 0 even if the RE bit is cleared to 0.

**Receive Data Sampling Timing and Reception Margin in Asynchronous Mode:**

In asynchronous mode, the SCI operates on a basic clock with a frequency of 16 times the transfer rate.

In reception, the SCI samples the falling edge of the start bit using the basic clock, and performs internal synchronization. Receive data is latched internally at the rising edge of the 8th pulse of the basic clock. This is illustrated in figure 16-23.



**Figure 16-23 Receive Data Sampling Timing in Asynchronous Mode**

Thus the reception margin in asynchronous mode is given by formula (1) below.

$$M = \left| \left( 0.5 - \frac{1}{2N} \right) - (L - 0.5) F - \frac{|D - 0.5|}{N} (1 + F) \right| \times 100\%$$

... Formula (1)

- Where
- M : Reception margin (%)
  - N : Ratio of bit rate to clock (N = 16)
  - D : Clock duty (D = 0 to 1.0)
  - L : Frame length (L = 9 to 12)
  - F : Absolute value of clock rate deviation

Assuming values of F = 0 and D = 0.5 in formula (1), a reception margin of 46.875% is given by formula (2) below.

When D = 0.5 and F = 0,

$$M = \left( 0.5 - \frac{1}{2 \times 16} \right) \times 100\%$$

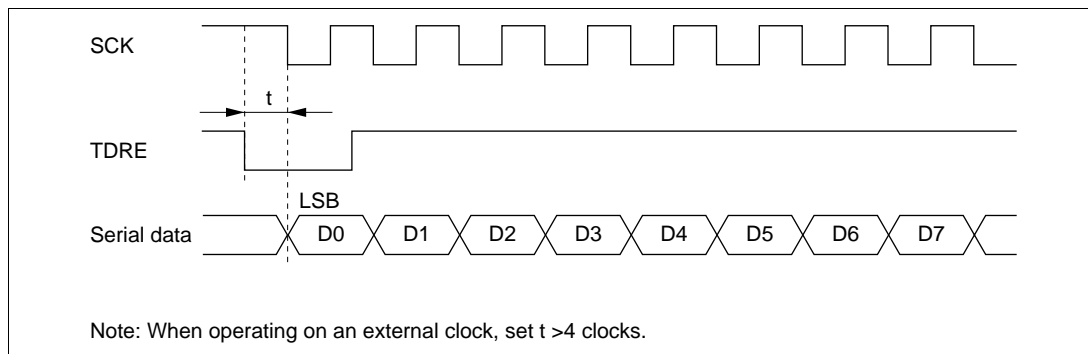
$$= 46.875\%$$

... Formula (2)

However, this is only the computed value, and a margin of 20% to 30% should be allowed in system design.

### Restrictions on Use of DMAC\* or DTC\*

- When an external clock source is used as the serial clock, the transmit clock should not be input until at least 5  $\phi$  clock cycles after TDR is updated by the DMAC or DTC. Misoperation may occur if the transmit clock is input within 4  $\phi$  clocks after TDR is updated. (Figure 16-24)
- When RDR is read by the DMAC\* or DTC\*, be sure to set the activation source to the relevant SCI reception end interrupt (RXI).



**Figure 16-24 Example of Clocked Synchronous Transmission by DTC\***

Note: \* DMAC and DTC functions are not available in the H8S/2695.

### Operation in Case of Mode Transition

- Transmission

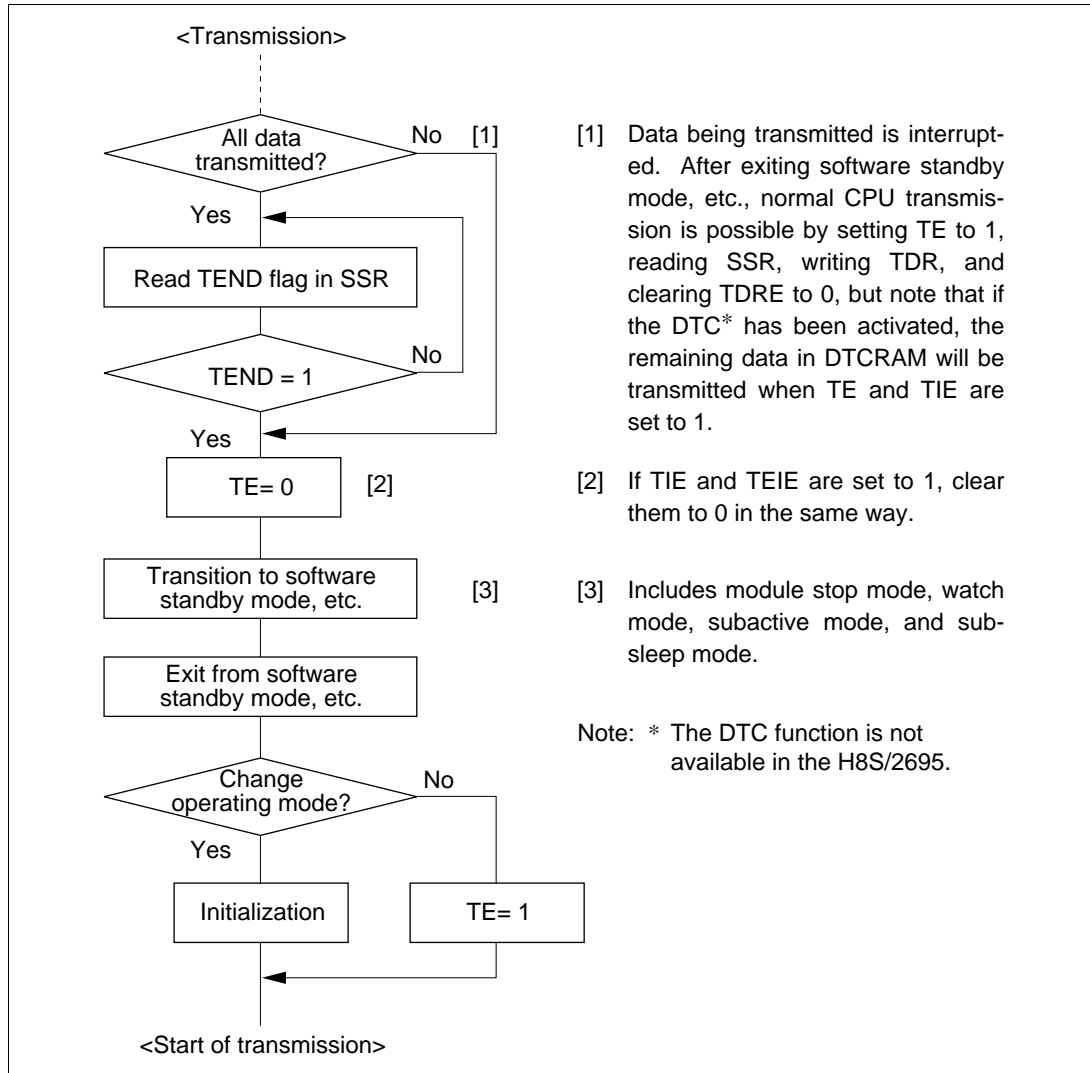
Operation should be stopped (by clearing TE, TIE, and TEIE to 0) before making a module stop mode, software standby mode, watch mode, subactive mode, or subsleep mode transition. TSR, TDR, and SSR are reset. The output pin states in module stop mode, software standby mode, watch mode, subactive mode, or subsleep mode depend on the port settings, and becomes high-level output after the relevant mode is cleared. If a transition is made during transmission, the data being transmitted will be undefined. When transmitting without changing the transmit mode after the relevant mode is cleared, transmission can be started by setting TE to 1 again, and performing the following sequence: SSR read -> TDR write -> TDRE clearance. To transmit with a different transmit mode after clearing the relevant mode, the procedure must be started again from initialization. Figure 16-25 shows a sample flowchart for mode transition during transmission. Port pin states are shown in figures 16-26 and 16-27. Operation should also be stopped (by clearing TE, TIE, and TEIE to 0) before making a transition from transmission by DTC transfer to module stop mode, software standby mode, watch mode, subactive mode, or subsleep mode transition. To perform transmission with the DTC after the relevant mode is cleared, setting TE and TIE to 1 will set the TXI flag and start DTC transmission.

- Reception

Receive operation should be stopped (by clearing RE to 0) before making a module stop mode, software standby mode, watch mode, subactive mode, or subsleep mode transition. RSR, RDR, and SSR are reset. If a transition is made without stopping operation, the data being received will be invalid.

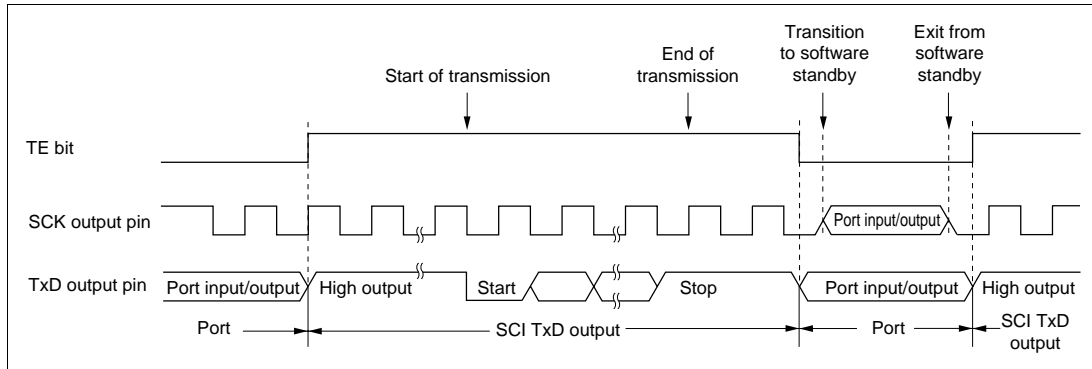
To continue receiving without changing the reception mode after the relevant mode is cleared, set RE to 1 before starting reception. To receive with a different receive mode, the procedure must be started again from initialization.

Figure 16-28 shows a sample flowchart for mode transition during reception.

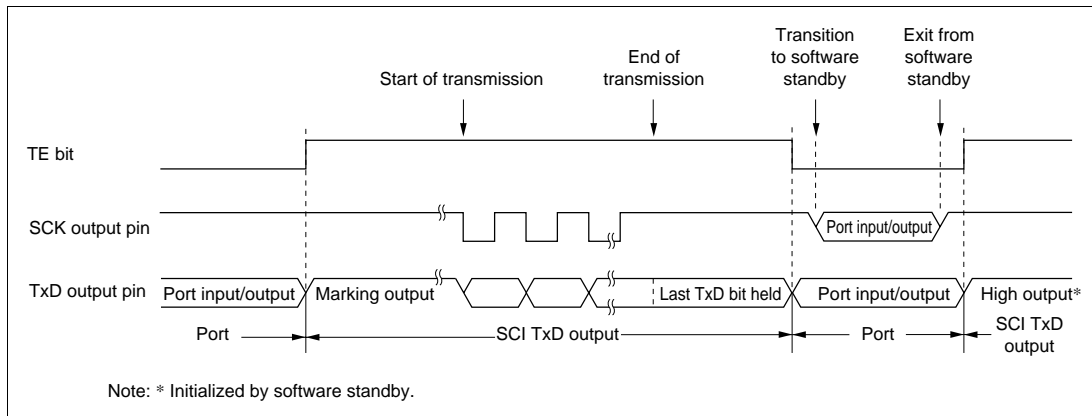


**Figure 16-25 Sample Flowchart for Mode Transition during Transmission**

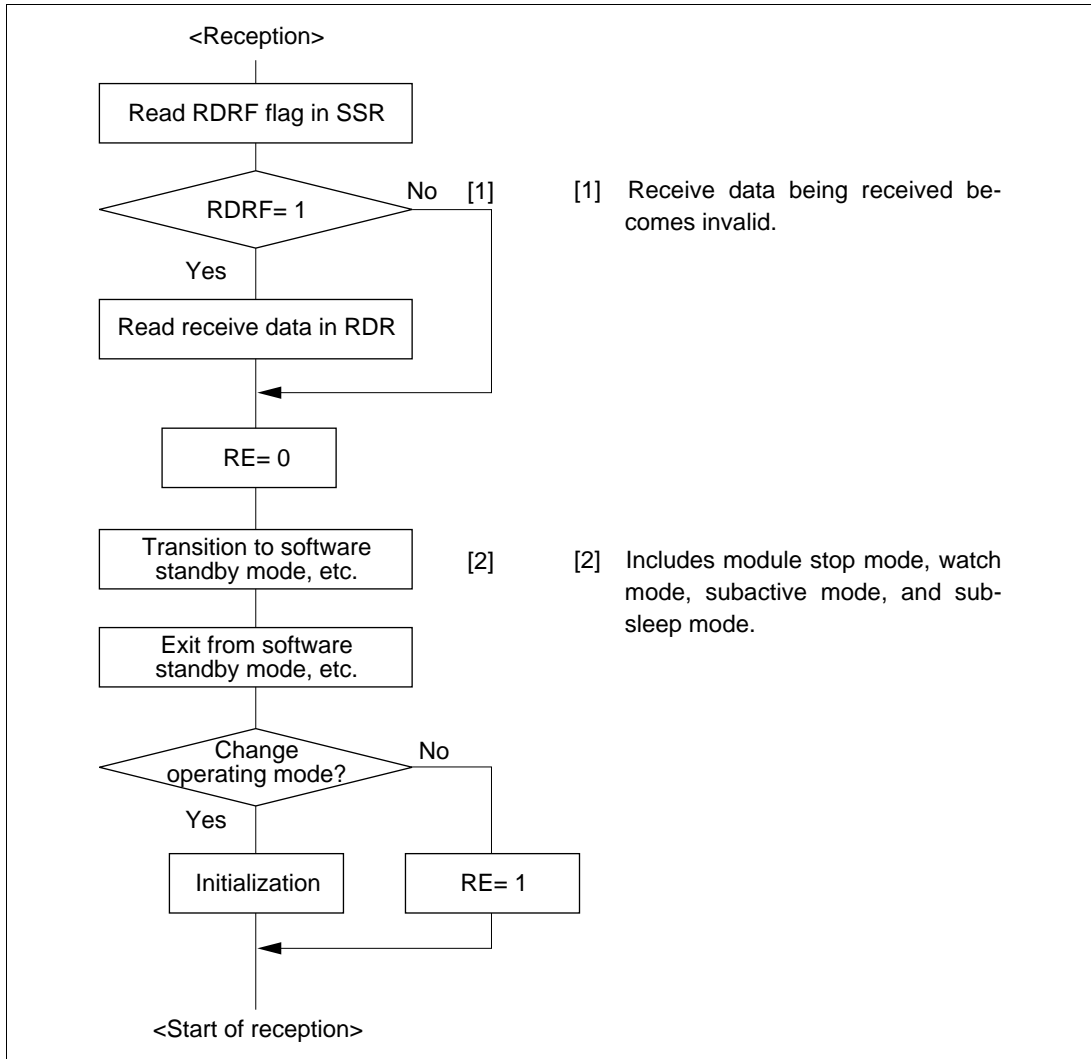




**Figure 16-26 Asynchronous Transmission Using Internal Clock**



**Figure 16-27 Synchronous Transmission Using Internal Clock**



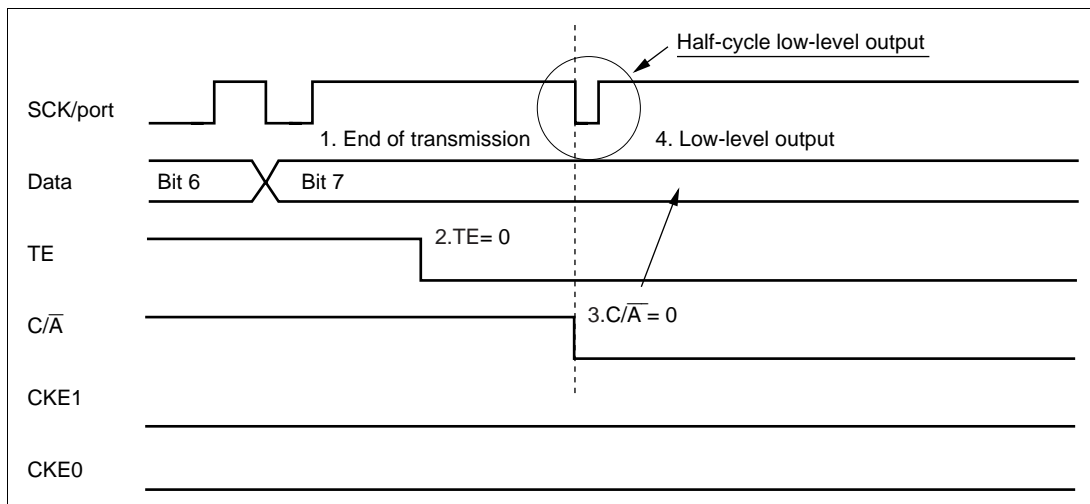
**Figure 16-28 Sample Flowchart for Mode Transition during Reception**

### Switching from SCK Pin Function to Port Pin Function:

- Problem in Operation: When switching the SCK pin to the output function while DDR and DR are set to 1 and clock synchronous SCI clock output is being used, low-level output occurs for one half-cycle, followed by port output.

When switching to the port function by making the following settings while DDR, DR, and  $C/\bar{A}$  are set to 1 and  $CKE1$ ,  $CKE0$ , and  $TE$  are set to 0, low-level output occurs for one half-cycle.

1. End of serial data transmission
2.  $TE$  bit = 0
3.  $C/\bar{A}$  bit = 0 ... switchover to port output
4. Occurrence of low-level output (see figure 16-29)

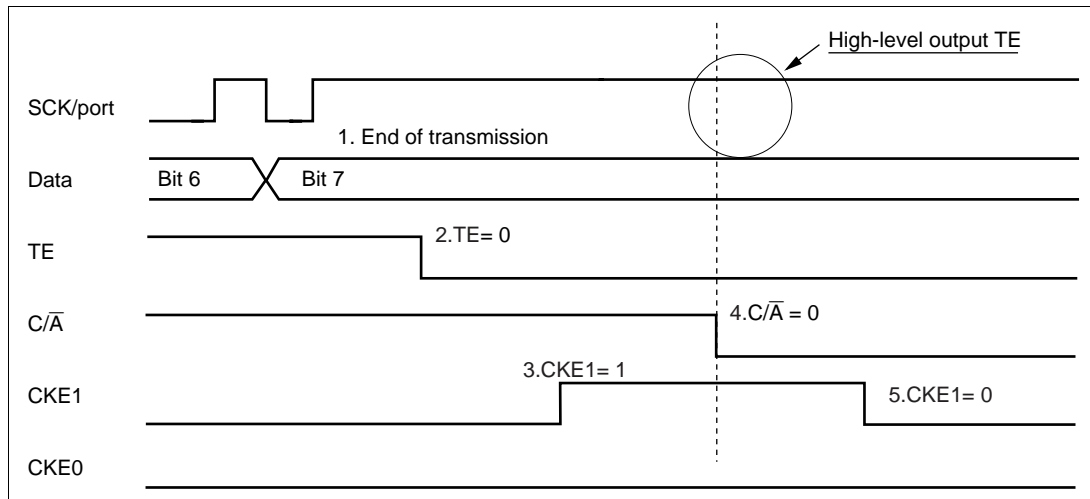


**Figure 16-29 Operation when Switching from SCK Pin Function to Port Pin Function**

- Sample Procedure for Avoiding Low-Level Output: As this sample procedure temporarily places the SCK pin in the input state, the SCK/port pin should be pulled up beforehand with an external circuit.

With  $DDR = 1$ ,  $DR = 1$ ,  $C/\bar{A} = 1$ ,  $CKE1 = 0$ ,  $CKE0 = 0$ , and  $TE = 1$ , make the following settings in the order shown.

1. End of serial data transmission
2. TE bit = 0
3. CKE1 bit = 1
4.  $C/\bar{A}$  bit = 0 ... switchover to port output
5. CKE1 bit = 0



**Figure 16-30 Operation when Switching from SCK Pin Function to Port Pin Function (Example of Preventing Low-Level Output)**

## Section 17 Smart Card Interface

### 17.1 Overview

SCI supports an IC card (Smart Card) interface conforming to ISO/IEC 7816-3 (Identification Card) as a serial communication interface extension function.

Switching between the normal serial communication interface and the Smart Card interface is carried out by means of a register setting.

#### 17.1.1 Features

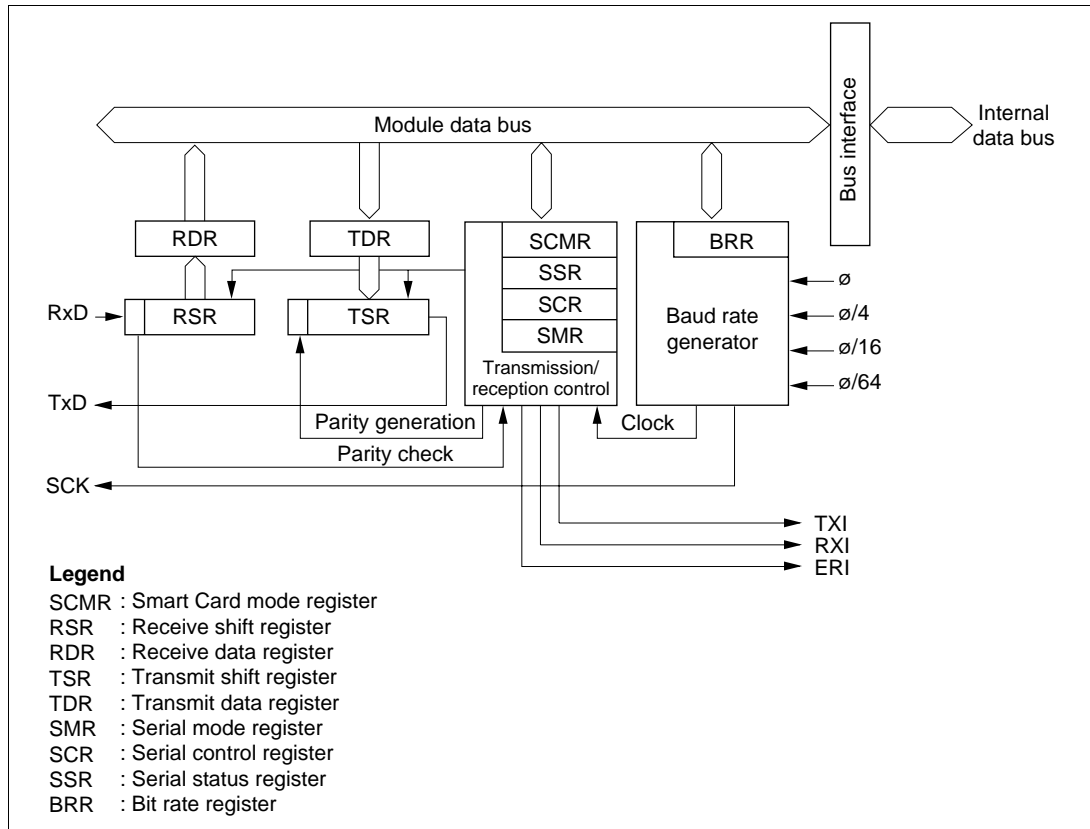
Features of the Smart Card interface supported by the H8S/2633 Series are as follows.

- Asynchronous mode
  - Data length: 8 bits
  - Parity bit generation and checking
  - Transmission of error signal (parity error) in receive mode
  - Error signal detection and automatic data retransmission in transmit mode
  - Direct convention and inverse convention both supported
- On-chip baud rate generator allows any bit rate to be selected
- Three interrupt sources
  - Three interrupt sources (transmit data empty, receive data full, and transmit/receive error) that can issue requests independently
  - The transmit data empty interrupt and receive data full interrupt can activate the DMA controller (DMAC)\* or data transfer controller (DTC)\* to execute data transfer

Note: \* DMAC and DTC functions are not available in the H8S/2695.

### 17.1.2 Block Diagram

Figure 17-1 shows a block diagram of the Smart Card interface.



**Figure 17-1 Block Diagram of Smart Card Interface**

### 17.1.3 Pin Configuration

Table 17-1 shows the Smart Card interface pin configuration.

**Table 17-1 Smart Card Interface Pins**

<b>Channel</b>	<b>Pin Name</b>	<b>Symbol</b>	<b>I/O</b>	<b>Function</b>
0	Serial clock pin 0	SCK0	I/O	SCI0 clock input/output
	Receive data pin 0	RxD0	Input	SCI0 receive data input
	Transmit data pin 0	TxD0	Output	SCI0 transmit data output
1	Serial clock pin 1	SCK1	I/O	SCI1 clock input/output
	Receive data pin 1	RxD1	Input	SCI1 receive data input
	Transmit data pin 1	TxD1	Output	SCI1 transmit data output
2	Serial clock pin 2	SCK2	I/O	SCI2 clock input/output
	Receive data pin 2	RxD2	Input	SCI2 receive data input
	Transmit data pin 2	TxD2	Output	SCI2 transmit data output
3	Serial clock pin 3	SCK3	I/O	SCI3 clock input/output
	Receive data pin 3	RxD3	Input	SCI3 receive data input
	Transmit data pin 3	TxD3	Output	SCI3 transmit data output
4	Serial clock pin 4	SCK4	I/O	SCI4 clock input/output
	Receive data pin 4	RxD4	Input	SCI4 receive data input
	Transmit data pin 4	TxD4	Output	SCI4 transmit data output

### 17.1.4 Register Configuration

Table 17-2 shows the registers used by the Smart Card interface. Details of BRR, TDR, RDR, and MSTPCR are the same as for the normal SCI function: see the register descriptions in section 16, Serial Communication Interface (SCI, IrDA).

**Table 17-2 Smart Card Interface Registers**

Channel	Name	Abbreviation	R/W	Initial Value	Address* <sup>1</sup>
0	Serial mode register 0	SMR0	R/W	H'00	H'FF78
	Bit rate register 0	BRR0	R/W	H'FF	H'FF79
	Serial control register 0	SCR0	R/W	H'00	H'FF7A
	Transmit data register 0	TDR0	R/W	H'FF	H'FF7B
	Serial status register 0	SSR0	R/(W)* <sup>2</sup>	H'84	H'FF7C
	Receive data register 0	RDR0	R	H'00	H'FF7D
	Smart card mode register 0	SCMR0	R/W	H'F2	H'FF7E
1	Serial mode register 1	SMR1	R/W	H'00	H'FF80
	Bit rate register 1	BRR1	R/W	H'FF	H'FF81
	Serial control register 1	SCR1	R/W	H'00	H'FF82
	Transmit data register 1	TDR1	R/W	H'FF	H'FF83
	Serial status register 1	SSR1	R/(W)* <sup>2</sup>	H'84	H'FF84
	Receive data register 1	RDR1	R	H'00	H'FF85
	Smart card mode register 1	SCMR1	R/W	H'F2	H'FF86
2	Serial mode register 2	SMR2	R/W	H'00	H'FF88
	Bit rate register 2	BRR2	R/W	H'FF	H'FF89
	Serial control register 2	SCR2	R/W	H'00	H'FF8A
	Transmit data register 2	TDR2	R/W	H'FF	H'FF8B
	Serial status register 2	SSR2	R/(W)* <sup>2</sup>	H'84	H'FF8C
	Receive data register 2	RDR2	R	H'00	H'FF8D
	Smart card mode register 2	SCMR2	R/W	H'F2	H'FF8E



Channel	Name	Abbreviation	R/W	Initial Value	Address* <sup>1</sup>
3	Serial mode register 3	SMR3	R/W	H'00	H'FDD0
	Bit rate register 3	BRR3	R/W	H'FF	H'FDD1
	Serial control register 3	SCR3	R/W	H'00	H'FDD2
	Transmit data register 3	TDR3	R/W	H'FF	H'FDD3
	Serial status register 3	SSR3	R/(W)* <sup>2</sup>	H'84	H'FDD4
	Receive data register 3	RDR3	R	H'00	H'FDD5
	Smart card mode register 3	SCMR3	R/W	H'F2	H'FDD6
4	Serial mode register 4	SMR4	R/W	H'00	H'FDD8
	Bit rate register 4	BRR4	R/W	H'FF	H'FDD9
	Serial control register 4	SCR4	R/W	H'00	H'FDDA
	Transmit data register 4	TDR4	R/W	H'FF	H'FDDB
	Serial status register 4	SSR4	R/(W)* <sup>2</sup>	H'84	H'FDDC
	Receive data register 4	RDR4	R	H'00	H'FDDD
	Smart card mode register 4	SCMR4	R/W	H'F2	H'FDDE
All	Module stop control register B, C	MSTPCRB	R/W	H'FF	H'FDE9
		MSTPCRC	R/W	H'FF	H'FDEA

Notes: \*1 Lower 16 bits of the address.

\*2 Can only be written with 0 for flag clearing.

## 17.2 Register Descriptions

Registers added with the Smart Card interface and bits for which the function changes are described here.

### 17.2.1 Smart Card Mode Register (SCMR)

Bit	:	7	6	5	4	3	2	1	0
		—	—	—	—	SDIR	SINV	—	SMIF
Initial value	:	1	1	1	1	0	0	1	0
R/W	:	—	—	—	—	R/W	R/W	—	R/W

SCMR is an 8-bit readable/writable register that selects the Smart Card interface function.

SCMR is initialized to H'F2 by a reset and in hardware standby mode.

**Bits 7 to 4—Reserved:** These bits are always read as 1 and cannot be modified.

**Bit 3—Smart Card Data Transfer Direction (SDIR):** Selects the serial/parallel conversion format.

#### Bit 3

SDIR	Description
0	TDR contents are transmitted LSB-first Receive data is stored in RDR LSB-first (Initial value)
1	TDR contents are transmitted MSB-first Receive data is stored in RDR MSB-first

**Bit 2—Smart Card Data Invert (SINV):** Specifies inversion of the data logic level. This function is used together with the SDIR bit for communication with an inverse convention card. The SINV bit does not affect the logic level of the parity bit. For parity-related setting procedures, see section 17.3.4, Register Settings.

**Bit 2**

<b>SINV</b>	<b>Description</b>	
0	TDR contents are transmitted as they are Receive data is stored as it is in RDR	(Initial value)
1	TDR contents are inverted before being transmitted Receive data is stored in inverted form in RDR	

**Bit 1—Reserved:** This bit is always read as 1 and cannot be modified.

**Bit 0—Smart Card Interface Mode Select (SMIF):** Enables or disables the Smart Card interface function.

**Bit 0**

<b>SMIF</b>	<b>Description</b>	
0	Smart Card interface function is disabled	(Initial value)
1	Smart Card interface function is enabled	

### 17.2.2 Serial Status Register (SSR)

Bit	:	7	6	5	4	3	2	1	0
		TDRE	RDRF	ORER	ERS	PER	TEND	MPB	MPBT
Initial value :		1	0	0	0	0	1	0	0
R/W	:	R/(W)*	R/(W)*	R/(W)*	R/(W)*	R/(W)*	R	R	R/W

Note: \* Only 0 can be written, to clear these flags.

Bit 4 of SSR has a different function in Smart Card interface mode. Coupled with this, the setting conditions for bit 2, TEND, are also different.

**Bits 7 to 5**—Operate in the same way as for the normal SCI. For details, see section 16.2.7, Serial Status Register (SSR).

**Bit 4—Error Signal Status (ERS):** In Smart Card interface mode, bit 4 indicates the status of the error signal sent back from the receiving end in transmission. Framing errors are not detected in Smart Card interface mode.

#### Bit 4

ERS	Description
0	Normal reception, with no error signal [Clearing conditions] (Initial value) <ul style="list-style-type: none"> <li>• Upon reset, and in standby mode or module stop mode</li> <li>• When 0 is written to ERS after reading ERS = 1</li> </ul>
1	Error signal sent from receiver indicating detection of parity error [Setting condition] When the low level of the error signal is sampled

Note: Clearing the TE bit in SCR to 0 does not affect the ERS flag, which retains its previous state.

**Bits 3 to 0**—Operate in the same way as for the normal SCI. For details, see section 16.2.7, Serial Status Register (SSR).

However, the setting conditions for the TEND bit, are as shown below.

**Bit 2**

TEND	Description
0	Transmission is in progress [Clearing conditions] <span style="float: right;">(Initial value)</span> <ul style="list-style-type: none"> <li>• When 0 is written to TDRE after reading TDRE = 1</li> <li>• When the DMAC* or DTC* is activated by a TXI interrupt and write data to TDR</li> </ul>
1	Transmission has ended [Setting conditions] <ul style="list-style-type: none"> <li>• Upon reset, and in standby mode or module stop mode</li> <li>• When the TE bit in SCR is 0 and the ERS bit is also 0</li> <li>• When TDRE = 1 and ERS = 0 (normal transmission) 2.5 etu after transmission of a 1-byte serial character when GM = 0 and BLK = 0</li> <li>• When TDRE = 1 and ERS = 0 (normal transmission) 1.5 etu after transmission of a 1-byte serial character when GM = 0 and BLK = 1</li> <li>• When TDRE = 1 and ERS = 0 (normal transmission) 1.0 etu after transmission of a 1-byte serial character when GM = 1 and BLK = 0</li> <li>• When TDRE = 1 and ERS = 0 (normal transmission) 1.0 etu after transmission of a 1-byte serial character when GM = 1 and BLK = 1</li> </ul>

Notes: etu: Elementary Time Unit (time for transfer of 1 bit)

\* DMAC and DTC functions are not available in the H8S/2695.

### 17.2.3 Serial Mode Register (SMR)

Bit	:	7	6	5	4	3	2	1	0
		GM	BLK	PE	O/ $\bar{E}$	BCP1	BCP0	CKS1	CKS0
Initial value :		0	0	0	0	0	0	0	0
R/W	:	R/W	R/W	R/W	R/W	R/W	R/W	R/W	R/W

Note: When the smart card interface is used, be sure to make the 1 setting shown for bit 5.

The function of bits 7, 6, 3, and 2 of SMR changes in Smart Card interface mode.

**Bit 7—GSM Mode (GM):** Sets the smart card interface function to GSM mode.

This bit is cleared to 0 when the normal smart card interface is used. In GSM mode, this bit is set to 1, the timing of setting of the TEND flag that indicates transmission completion is advanced and clock output control mode addition is performed. The contents of the clock output control mode addition are specified by bits 1 and 0 of the serial control register (SCR).

#### Bit 7

GM	Description
0	Normal smart card interface mode operation (Initial value) <ul style="list-style-type: none"> <li>TEND flag generation 12.5 etu (11.5 etu in block transfer mode) after beginning of start bit</li> <li>Clock output ON/OFF control only</li> </ul>
1	GSM mode smart card interface mode operation <ul style="list-style-type: none"> <li>TEND flag generation 11.0 etu after beginning of start bit</li> <li>High/low fixing control possible in addition to clock output ON/OFF control (set by SCR)</li> </ul>

Note: etu: Elementary time unit (time for transfer of 1 bit)

**Bit 6—Block Transfer Mode (BLK):** Selects block transfer mode.

**Bit 6**

BLK	Description
0	Normal Smart Card interface mode operation <ul style="list-style-type: none"> <li>• Error signal transmission/detection and automatic data retransmission performed</li> <li>• TXI interrupt generated by TEND flag</li> <li>• TEND flag set 12.5 etu after start of transmission (11.0 etu in GSM mode)</li> </ul>
1	Block transfer mode operation <ul style="list-style-type: none"> <li>• Error signal transmission/detection and automatic data retransmission not performed</li> <li>• TXI interrupt generated by TDRE flag</li> <li>• TEND flag set 11.5 etu after start of transmission (11.0 etu in GSM mode)</li> </ul>

Note: etu: Elementary time unit (time for transfer of 1 bit)

**Bits 3 and 2—Basic Clock Pulse 1 and 2 (BCP1, BCP0):** These bits specify the number of basic clock periods in a 1-bit transfer interval on the Smart Card interface.

Bit 3	Bit 2	Description
BCP1	BCP0	
0	1	32 clock periods (Initial value)
	0	64 clock periods
1	1	372 clock periods
	0	256 clock periods

**Bits 5, 4, 1, and 0:** Operate in the same way as for the normal SCI. For details, see section 16.2.5, Serial Mode Register (SMR).

### 17.2.4 Serial Control Register (SCR)

Bit	:	7	6	5	4	3	2	1	0
		TIE	RIE	TE	RE	MPIE	TEIE	CKE1	CKE0
Initial value :		0	0	0	0	0	0	0	0
R/W	:	R/W	R/W	R/W	R/W	R/W	R/W	R/W	R/W

In smart card interface mode, the function of bits 1 and 0 of SCR changes when bit 7 of the serial mode register (SMR) is set to 1.

**Bits 7 to 2**—Operate in the same way as for the normal SCI.

For details, see section 16.2.6, Serial Control Register (SCR).

**Bits 1 and 0—Clock Enable 1 and 0 (CKE1, CKE0):** These bits are used to select the SCI clock source and enable or disable clock output from the SCK pin.

In smart card interface mode, in addition to the normal switching between clock output enabling and disabling, the clock output can be specified as to be fixed high or low.

SCMR	SMR	SCR Setting		SCK Pin Function
SMIF	C/A, GM	CKE1	CKE0	
0	See the SCI			
1	0	0	0	Operates as port I/O pin
1	0	0	1	Outputs clock as SCK output pin
1	1	0	0	Operates as SCK output pin, with output fixed low
1	1	0	1	Outputs clock as SCK output pin
1	1	1	0	Operates as SCK output pin, with output fixed high
1	1	1	1	Outputs clock as SCK output pin



## 17.3 Operation

### 17.3.1 Overview

The main functions of the Smart Card interface are as follows.

- One frame consists of 8-bit data plus a parity bit.
- In transmission, a guard time of at least 2 etu (1 etu in the block transfer mode) is left between the end of the parity bit and the start of the next frame.
- If a parity error is detected during reception, a low error signal level is output for one etu period, 10.5 etu after the start bit.
- If the error signal is sampled during transmission, the same data is transmitted automatically after the elapse of 2 etu or longer. (except in block transfer mode)
- Only asynchronous communication is supported; there is no clocked synchronous communication function.

Note: etu: Elementary time unit (time for transfer of 1 bit)

### 17.3.2 Pin Connections

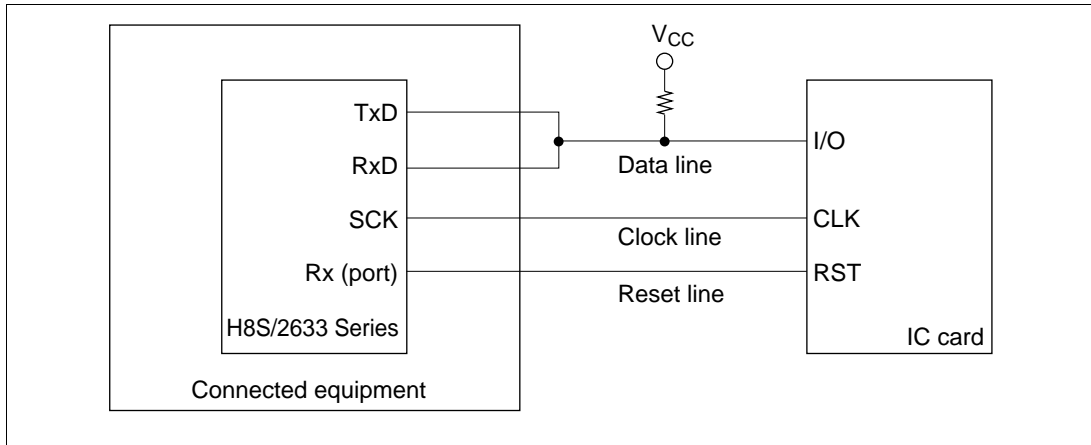
Figure 17-2 shows a schematic diagram of Smart Card interface related pin connections.

In communication with an IC card, since both transmission and reception are carried out on a single data transmission line, the TxD pin and RxD pin should be connected with the LSI pin. The data transmission line should be pulled up to the  $V_{CC}$  power supply with a resistor.

When the clock generated on the Smart Card interface is used by an IC card, the SCK pin output is input to the CLK pin of the IC card. No connection is needed if the IC card uses an internal clock.

LSI port output is used as the reset signal.

Other pins must normally be connected to the power supply or ground.



**Figure 17-2 Schematic Diagram of Smart Card Interface Pin Connections**

Note: If an IC card is not connected, and the TE and RE bits are both set to 1, closed transmission/reception is possible, enabling self-diagnosis to be carried out.

### 17.3.3 Data Format

#### (1) Normal Transfer Mode

Figure 17-3 shows the normal Smart Card interface data format. In reception in this mode, a parity check is carried out on each frame, and if an error is detected an error signal is sent back to the transmitting end, and retransmission of the data is requested. If an error signal is sampled during transmission, the same data is retransmitted.

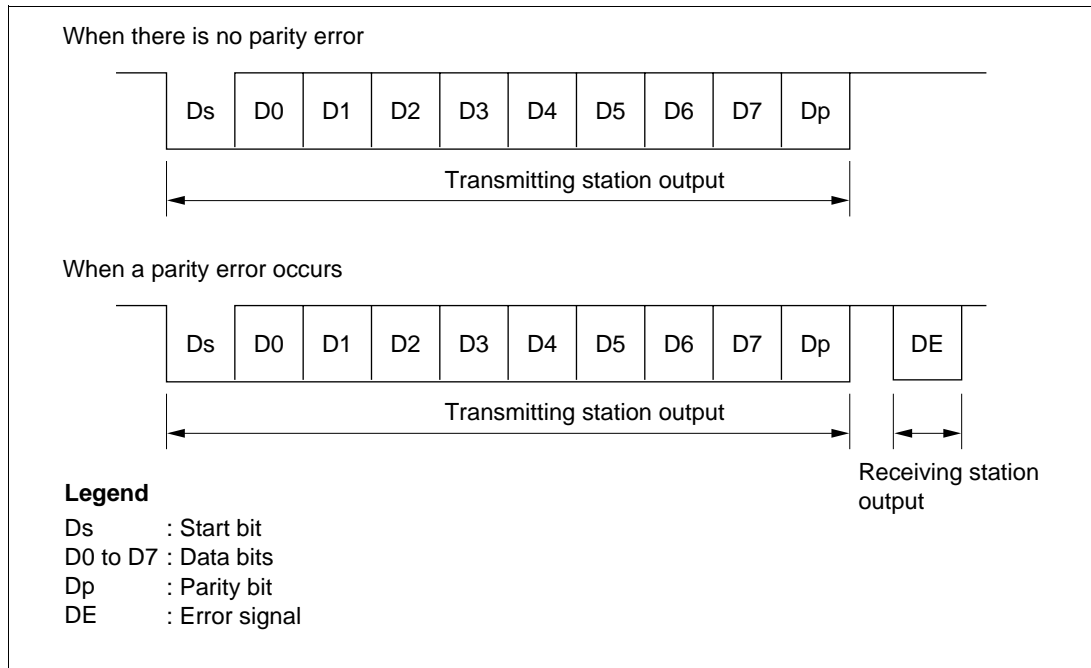


Figure 17-3 Normal Smart Card Interface Data Format

The operation sequence is as follows.

- [1] When the data line is not in use it is in the high-impedance state, and is fixed high with a pull-up resistor.
- [2] The transmitting station starts transfer of one frame of data. The data frame starts with a start bit (Ds, low-level), followed by 8 data bits (D0 to D7) and a parity bit (Dp).
- [3] With the Smart Card interface, the data line then returns to the high-impedance state. The data line is pulled high with a pull-up resistor.
- [4] The receiving station carries out a parity check.  
If there is no parity error and the data is received normally, the receiving station waits for reception of the next data.  
If a parity error occurs, however, the receiving station outputs an error signal (DE, low-level) to request retransmission of the data. After outputting the error signal for the prescribed length of time, the receiving station places the signal line in the high-impedance state again. The signal line is pulled high again by a pull-up resistor.
- [5] If the transmitting station does not receive an error signal, it proceeds to transmit the next data frame.  
If it does receive an error signal, however, it returns to step [2] and retransmits the erroneous data.

## **(2) Block Transfer Mode**

The operation sequence in block transfer mode is as follows.

- [1] When the data line is not in use it is in the high-impedance state, and is fixed high with a pull-up resistor.
- [2] The transmitting station starts transfer of one frame of data. The data frame starts with a start bit (Ds, low-level), followed by 8 data bits (D0 to D7) and a parity bit (Dp).
- [3] With the Smart Card interface, the data line then returns to the high-impedance state. The data line is pulled high with a pull-up resistor.
- [4] After reception, a parity error check is carried out, but an error signal is not output even if an error has occurred. When an error occurs reception cannot be continued, so the error flag should be cleared to 0 before the parity bit of the next frame is received.
- [5] The transmitting station proceeds to transmit the next data frame.

### 17.3.4 Register Settings

Table 17-3 shows a bit map of the registers used by the smart card interface.

Bits indicated as 0 or 1 must be set to the value shown. The setting of other bits is described below.

**Table 17-3 Smart Card Interface Register Settings**

Register	Bit							
	Bit 7	Bit 6	Bit 5	Bit 4	Bit 3	Bit 2	Bit 1	Bit 0
SMR	GM	BLK	1	O/ $\bar{E}$	BCP1	BCP0	CKS1	CKS0
BRR	BRR7	BRR6	BRR5	BRR4	BRR3	BRR2	BRR1	BRR0
SCR	TIE	RIE	TE	RE	0	0	CKE1*	CKE0
TDR	TDR7	TDR6	TDR5	TDR4	TDR3	TDR2	TDR1	TDR0
SSR	TDRE	RDRF	ORER	ERS	PER	TEND	0	0
RDR	RDR7	RDR6	RDR5	RDR4	RDR3	RDR2	RDR1	RDR0
SCMR	—	—	—	—	SDIR	SINV	—	SMIF

Notes: — : Unused bit.

\*: The CKE1 bit must be cleared to 0 when the GM bit in SMR is cleared to 0.

**SMR Setting:** The GM bit is cleared to 0 in normal smart card interface mode, and set to 1 in GSM mode. The O/ $\bar{E}$  bit is cleared to 0 if the IC card is of the direct convention type, and set to 1 if of the inverse convention type.

Bits CKS1 and CKS0 select the clock source of the on-chip baud rate generator. Bits BCP1 and BCP0 select the number of basic clock periods in a 1-bit transfer interval. For details, see section 17.3.5, Clock.

The BLK bit is cleared to 0 in normal smart card interface mode, and set to 1 in block transfer mode.

**BRR Setting:** BRR is used to set the bit rate. See section 17.3.5, Clock, for the method of calculating the value to be set.

**SCR Setting:** The function of the TIE, RIE, TE, and RE bits is the same as for the normal SCI. For details, see section 16, Serial Communication Interface (SCI, IrDA).

Bits CKE1 and CKE0 specify the clock output. When the GM bit in SMR is cleared to 0, set these bits to B'00 if a clock is not to be output, or to B'01 if a clock is to be output. When the GM bit in SMR is set to 1, clock output is performed. The clock output can also be fixed high or low.

**Smart Card Mode Register (SCMR) Setting:**

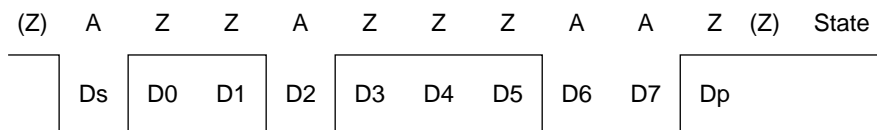
The SDIR bit is cleared to 0 if the IC card is of the direct convention type, and set to 1 if of the inverse convention type.

The SINV bit is cleared to 0 if the IC card is of the direct convention type, and set to 1 if of the inverse convention type.

The SMIF bit is set to 1 in the case of the Smart Card interface.

Examples of register settings and the waveform of the start character are shown below for the two types of IC card (direct convention and inverse convention).

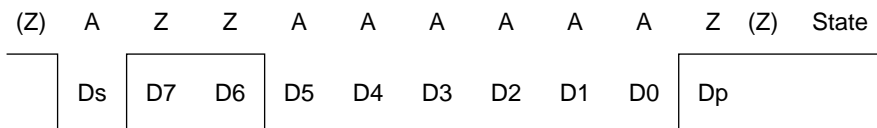
- Direct convention ( $SDIR = SINV = O/\bar{E} = 0$ )



With the direct convention type, the logic 1 level corresponds to state Z and the logic 0 level to state A, and transfer is performed in LSB-first order. The start character data above is H'3B.

The parity bit is 1 since even parity is stipulated for the Smart Card.

- Inverse convention ( $SDIR = SINV = O/\bar{E} = 1$ )



With the inverse convention type, the logic 1 level corresponds to state A and the logic 0 level to state Z, and transfer is performed in MSB-first order. The start character data above is H'3F.

The parity bit is 0, corresponding to state Z, since even parity is stipulated for the Smart Card.

With the H8S/2633 Series, inversion specified by the SINV bit applies only to the data bits, D7 to D0. For parity bit inversion, the  $O/\bar{E}$  bit in SMR is set to odd parity mode (the same applies to both transmission and reception).

### 17.3.5 Clock

Only an internal clock generated by the on-chip baud rate generator can be used as the transmit/receive clock for the smart card interface. The bit rate is set with BRR and the CKS1, CKS0, BCP1 and BCP0 bits in SMR. The formula for calculating the bit rate is as shown below. Table 17-5 shows some sample bit rates.

If clock output is selected by setting CKE0 to 1, a clock is output from the SCK pin. The clock frequency is determined by the bit rate and the setting of bits BCP1 and BCP0.

$$B = \frac{\phi}{S \times 2^{2n+1} \times (N + 1)} \times 10^6$$

Where: N = Value set in BRR (0 ≤ N ≤ 255)

B = Bit rate (bit/s)

ϕ = Operating frequency (MHz)

n = See table 17-4

S = Number of internal clocks in 1-bit period, set by BCP1 and BCP0

**Table 17-4 Correspondence between n and CKS1, CKS0**

n	CKS1	CKS0
0	0	0
1		1
2	1	0
3		1

**Table 17-5 Examples of Bit Rate B (bit/s) for Various BRR Settings  
(When n = 0 and S = 372)**

N	ϕ (MHz)								
	10.00	10.714	13.00	14.285	16.00	18.00	20.00	25.00	28.00
0	13441	14400	17473	19200	21505	24194	26882	33602	37634
1	6720	7200	8737	9600	10753	12097	13441	16801	18817
2	4480	4800	5824	6400	7168	8065	8961	11201	12545

Note: Bit rates are rounded to the nearest whole number.

The method of calculating the value to be set in the bit rate register (BRR) from the operating frequency and bit rate, on the other hand, is shown below. N is an integer,  $0 \leq N \leq 255$ , and the smaller error is specified.

$$N = \frac{\phi}{S \times 2^{2n+1} \times B} \times 10^6 - 1$$

**Table 17-6 Examples of BRR Settings for Bit Rate B (bit/s) (When n = 0 and S = 372)**

		$\phi$ (MHz)																			
		7.1424	10.00		10.7136		13.00		14.2848		16.00		18.00		20.00		25.00		28.00		
bit/s	N Error	N	Error	N	Error	N	Error	N	Error	N	Error	N	Error	N	Error	N	Error	N	Error	N	Error
9600	0 0.00	1	30	1	25	1	8.99	1	0.00	1	12.01	2	15.99	2	6.60	3	12.49	3	1.99		

**Table 17-7 Maximum Bit Rate at Various Frequencies (Smart Card Interface Mode) (when S = 372)**

$\phi$ (MHz)	Maximum Bit Rate (bit/s)	N	n
7.1424	9600	0	0
10.00	13441	0	0
10.7136	14400	0	0
13.00	17473	0	0
14.2848	19200	0	0
16.00	21505	0	0
18.00	24194	0	0
20.00	26882	0	0
25.00	33602	0	0
28.00	37634	0	0

The bit rate error is given by the following formula:

$$\text{Error (\%)} = \left( \frac{\phi}{S \times 2^{2n+1} \times B \times (N + 1)} \times 10^6 - 1 \right) \times 100$$



### 17.3.6 Data Transfer Operations

**Initialization:** Before transmitting and receiving data, initialize the SCI as described below. Initialization is also necessary when switching from transmit mode to receive mode, or vice versa.

- [1] Clear the TE and RE bits in SCR to 0.
- [2] Clear the error flags ERS, PER, and ORER in SSR to 0.
- [3] Set the GM, BLK,  $O/\bar{E}$ , BCP1, BCP0, CKS1, and CKS0 bits in SMR. Set the PE bit to 1.
- [4] Set the SMIF, SDIR, and SINV bits in SCMR.  
When the SMIF bit is set to 1, the TxD and RxD pins are both switched from ports to SCI pins, and are placed in the high-impedance state.
- [5] Set the value corresponding to the bit rate in BRR.
- [6] Set the CKE0 and CKE1 bits in SCR. Clear the TIE, RIE, TE, RE, MPIE, and TEIE bits to 0.  
If the CKE0 bit is set to 1, the clock is output from the SCK pin.
- [7] Wait at least one bit interval, then set the TIE, RIE, TE, and RE bits in SCR. Do not set the TE bit and RE bit at the same time, except for self-diagnosis.

**Serial Data Transmission:** As data transmission in smart card mode involves error signal sampling and retransmission processing, the processing procedure is different from that for the normal SCI. Figure 17-4 shows a flowchart for transmitting, and figure 17-5 shows the relation between a transmit operation and the internal registers.

- [1] Perform Smart Card interface mode initialization as described above in Initialization.
- [2] Check that the ERS error flag in SSR is cleared to 0.
- [3] Repeat steps [2] and [3] until it can be confirmed that the TEND flag in SSR is set to 1.
- [4] Write the transmit data to TDR, clear the TDRE flag to 0, and perform the transmit operation. The TEND flag is cleared to 0.
- [5] When transmitting data continuously, go back to step [2].
- [6] To end transmission, clear the TE bit to 0.

With the above processing, interrupt servicing or data transfer by the DMAC or DTC is possible.

If transmission ends and the TEND flag is set to 1 while the TIE bit is set to 1 and interrupt requests are enabled, a transmit data empty interrupt (TXI) request will be generated. If an error occurs in transmission and the ERS flag is set to 1 while the RIE bit is set to 1 and interrupt requests are enabled, a transfer error interrupt (ERI) request will be generated.

The timing for setting the TEND flag depends on the value of the GM bit in SMR. The TEND flag set timing is shown in figure 17-6.

If the DMAC or DTC is activated by a TXI request, the number of bytes set in the DMAC or DTC can be transmitted automatically, including automatic retransmission.

For details, see Interrupt Operation and Data Transfer Operation by DMAC or DTC below.

Note: For block transfer mode, see section 16.3.2, Operation in Asynchronous Mode.

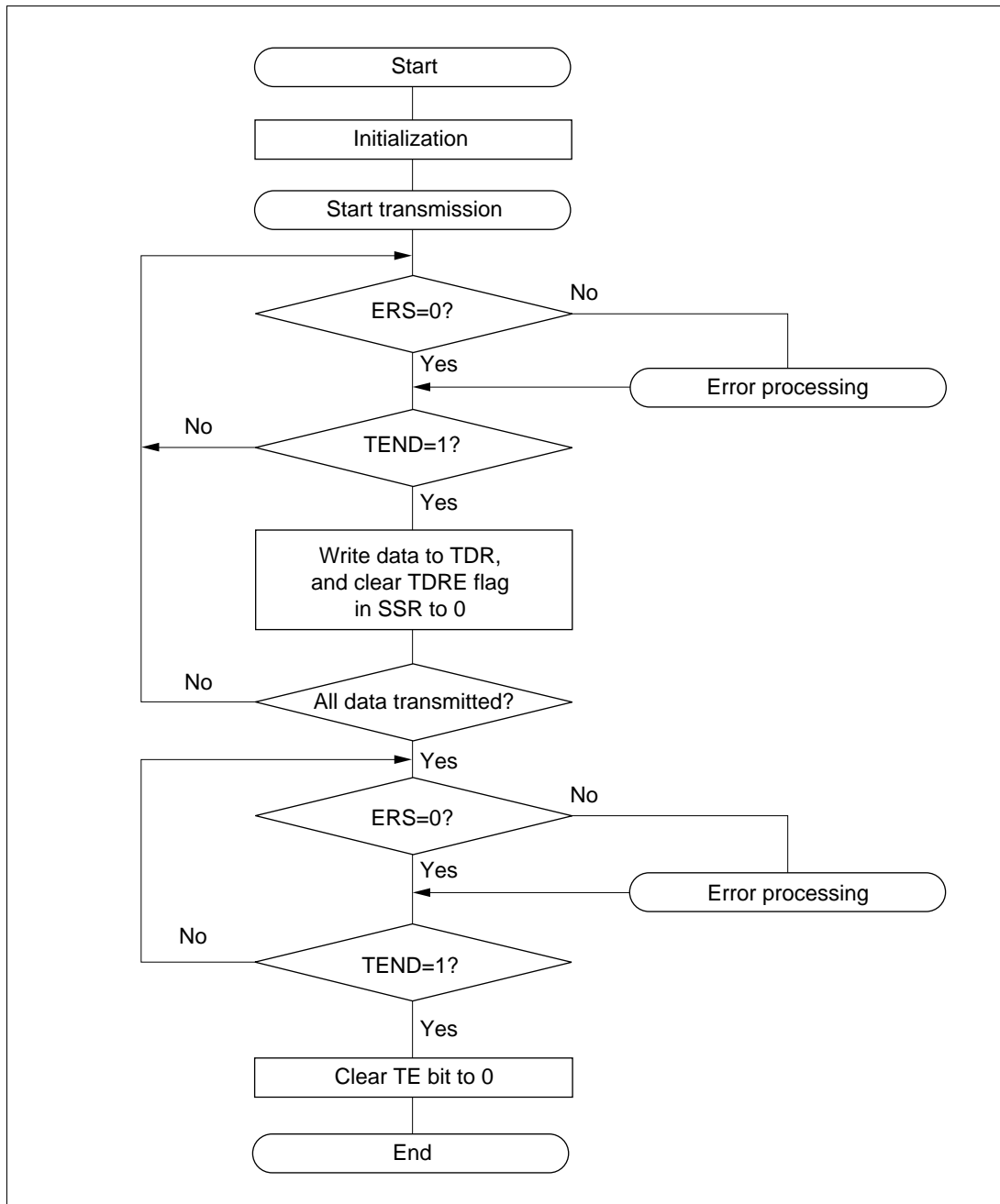
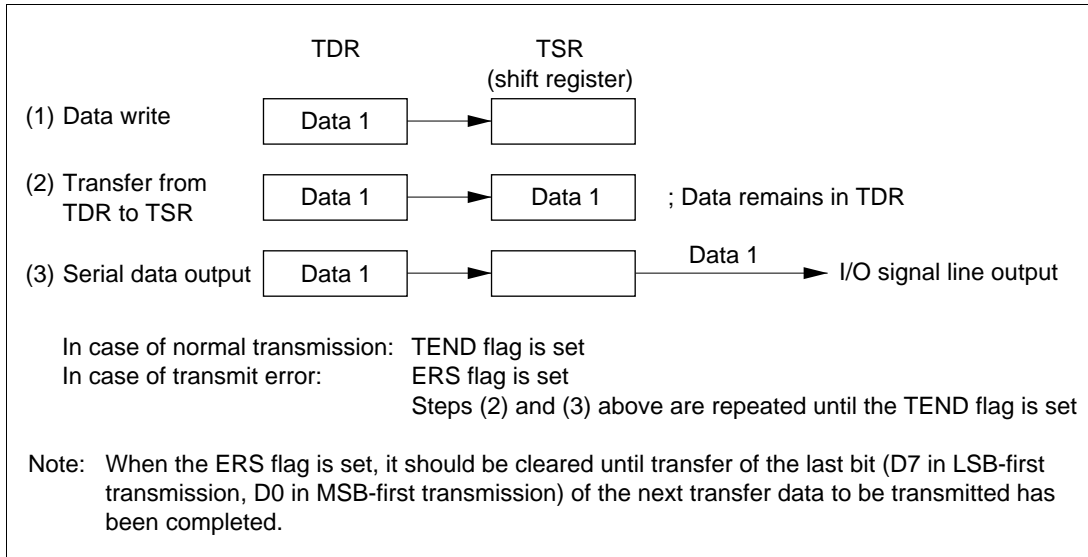
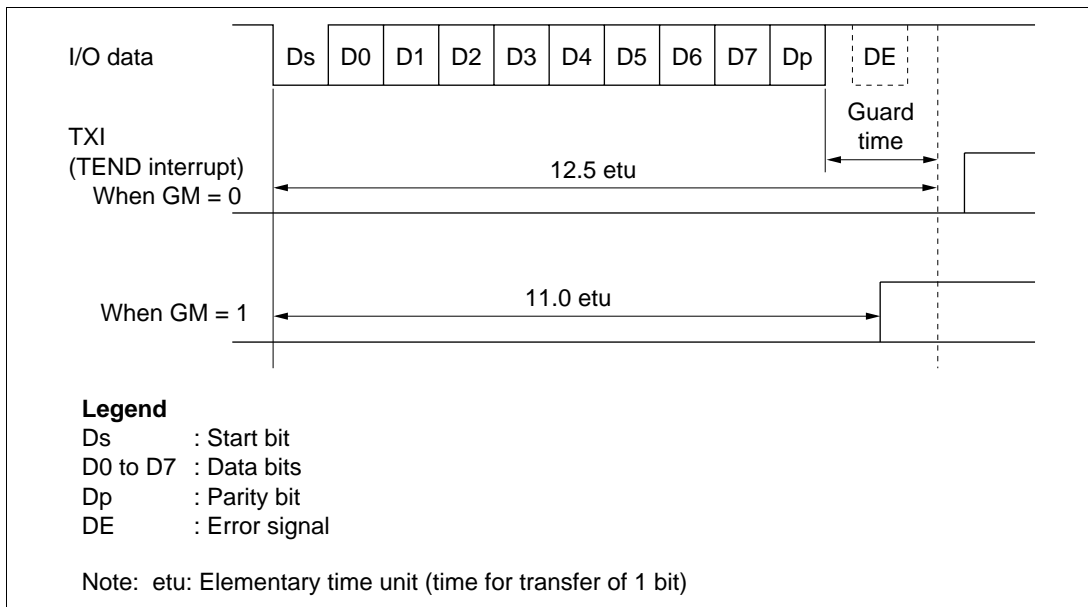


Figure 17-4 Example of Transmission Processing Flow



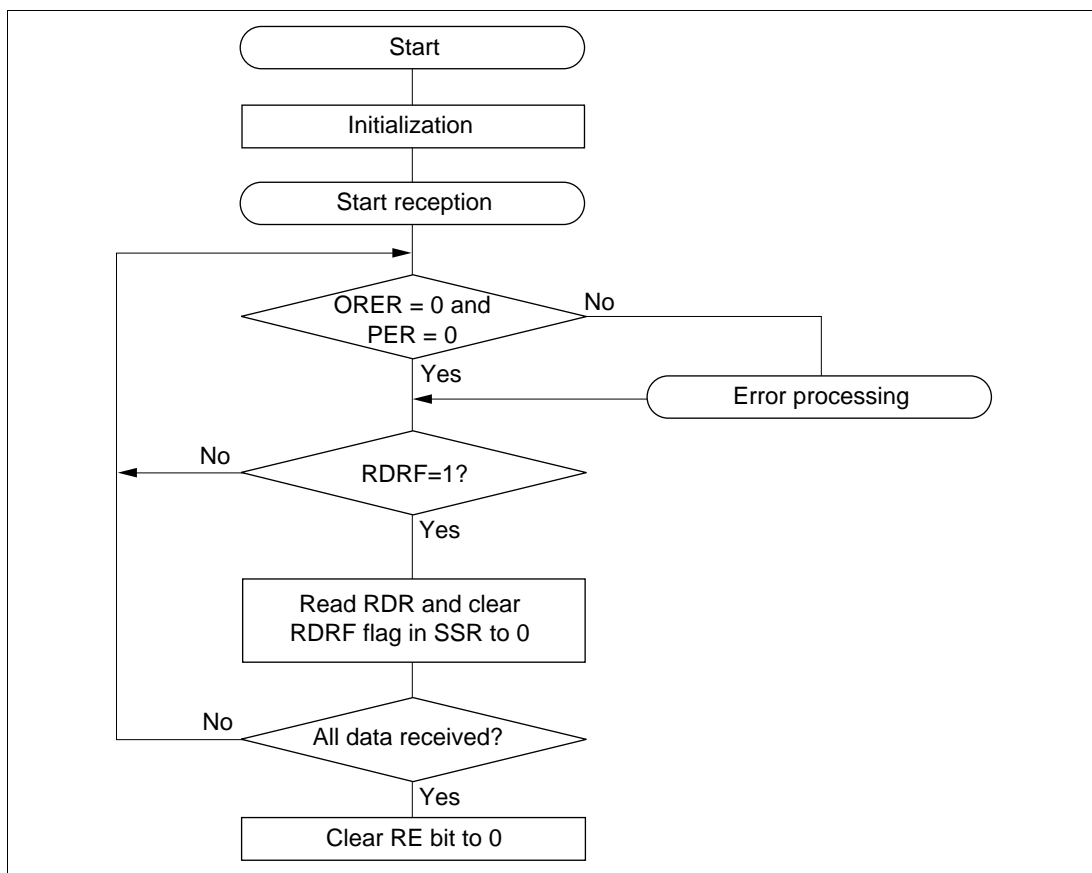
**Figure 17-5 Relation Between Transmit Operation and Internal Registers**



**Figure 17-6 TEND Flag Generation Timing in Transmission Operation**

**Serial Data Reception (Except Block Transfer Mode):** Data reception in Smart Card mode uses the same processing procedure as for the normal SCI. Figure 17-7 shows an example of the transmission processing flow.

- [1] Perform Smart Card interface mode initialization as described above in Initialization.
- [2] Check that the ORER flag and PER flag in SSR are cleared to 0. If either is set, perform the appropriate receive error processing, then clear both the ORER and the PER flag to 0.
- [3] Repeat steps [2] and [3] until it can be confirmed that the RDRF flag is set to 1.
- [4] Read the receive data from RDR.
- [5] When receiving data continuously, clear the RDRF flag to 0 and go back to step [2].
- [6] To end reception, clear the RE bit to 0.



**Figure 17-7 Example of Reception Processing Flow**

With the above processing, interrupt servicing or data transfer by the DMAC or DTC is possible.

If reception ends and the RDRF flag is set to 1 while the RIE bit is set to 1 and interrupt requests are enabled, a receive data full interrupt (RXI) request will be generated. If an error occurs in reception and either the ORER flag or the PER flag is set to 1, a transfer error interrupt (ERI) request will be generated.

If the DMAC or DTC is activated by an RXI request, the receive data in which the error occurred is skipped, and only the number of bytes of receive data set in the DMAC or DTC are transferred.

For details, see Interrupt Operation and Data Transfer Operation by DMAC or DTC below.

If a parity error occurs during reception and the PER is set to 1, the received data is still transferred to RDR, and therefore this data can be read.

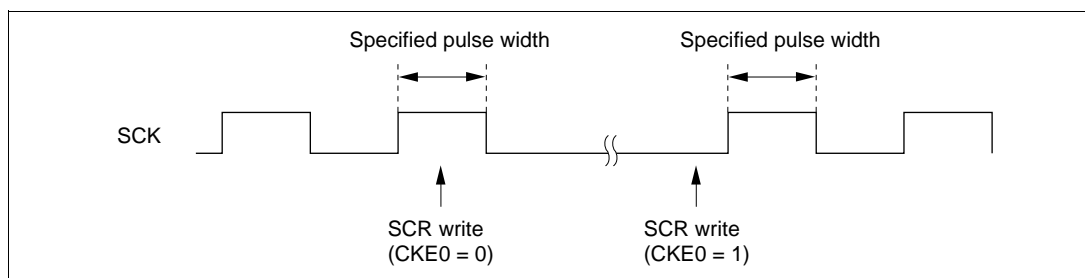
Note: For block transfer mode, see section 16.3.2, Operation in Asynchronous Mode.

**Mode Switching Operation:** When switching from receive mode to transmit mode, first confirm that the receive operation has been completed, then start from initialization, clearing RE bit to 0 and setting TE bit to 1. The RDRF flag or the PER and ORER flags can be used to check that the receive operation has been completed.

When switching from transmit mode to receive mode, first confirm that the transmit operation has been completed, then start from initialization, clearing TE bit to 0 and setting RE bit to 1. The TEND flag can be used to check that the transmit operation has been completed.

**Fixing Clock Output Level:** When the GM bit in SMR is set to 1, the clock output level can be fixed with bits CKE1 and CKE0 in SCR. At this time, the minimum clock pulse width can be made the specified width.

Figure 17-8 shows the timing for fixing the clock output level. In this example, GM is set to 1, CKE1 is cleared to 0, and the CKE0 bit is controlled.



**Figure 17-8 Timing for Fixing Clock Output Level**

**Interrupt Operation (Except Block Transfer Mode):** There are three interrupt sources in smart card interface mode: transmit data empty interrupt (TXI) requests, transfer error interrupt (ERI)

requests, and receive data full interrupt (RXI) requests. The transmit end interrupt (TEI) request is not used in this mode.

When the TEND flag in SSR is set to 1, a TXI interrupt request is generated.

When the RDRF flag in SSR is set to 1, an RXI interrupt request is generated.

When any of flags ORER, PER, and ERS in SSR is set to 1, an ERI interrupt request is generated. The relationship between the operating states and interrupt sources is shown in table 17-8.

Note: For block transfer mode, see section 16.4, SCI Interrupts.

**Table 17-8 Smart Card Mode Operating States and Interrupt Sources**

Operating State	Flag	Enable Bit	Interrupt Source	DMAC Activation	DTC Activation	
Transmit Mode	Normal operation	TEND	TIE	TXI	Possible	Possible
	Error	ERS	RIE	ERI	Not possible	Not possible
Receive Mode	Normal operation	RDRF	RIE	RXI	Possible	Possible
	Error	PER, ORER	RIE	ERI	Not possible	Not possible

**Data Transfer Operation by DMAC\* or DTC\*:** In smart card mode, as with the normal SCI, transfer can be carried out using the DMAC\* or DTC\*. In a transmit operation, the TDRE flag is also set to 1 at the same time as the TEND flag in SSR, and a TXI interrupt is generated. If the TXI request is designated beforehand as a DMAC\* or DTC\* activation source, the DMAC\* or DTC\* will be activated by the TXI request, and transfer of the transmit data will be carried out. The TDRE and TEND flags are automatically cleared to 0 when data transfer is performed by the DMAC\* or DTC\*. In the event of an error, the SCI retransmits the same data automatically. During this period, TEND remains cleared to 0 and the DMAC\* is not activated. Therefore, the SCI and DMAC\* will automatically transmit the specified number of bytes, including retransmission in the event of an error. However, the ERS flag is not cleared automatically when an error occurs, and so the RIE bit should be set to 1 beforehand so that an ERI request will be generated in the event of an error, and the ERS flag will be cleared.

When performing transfer using the DMAC\* or DTC\*, it is essential to set and enable the DMAC\* or DTC\* before carrying out SCI setting. For details of the DMAC\* or DTC\* setting procedures, see section 8, DMA Controller (DMAC\*) and section 9, Data Transfer Controller (DTC\*).

In a receive operation, an RXI interrupt request is generated when the RDRF flag in SSR is set to 1. If the RXI request is designated beforehand as a DMAC\* or DTC\* activation source, the DMAC\* or DTC\* will be activated by the RXI request, and transfer of the receive data will be

carried out. The RDRF flag is cleared to 0 automatically when data transfer is performed by the DMAC\* or DTC\*. If an error occurs, an error flag is set but the RDRF flag is not. Consequently, the DTC\* or DTC\* is not activated, but instead, an ERI interrupt request is sent to the CPU. Therefore, the error flag should be cleared.

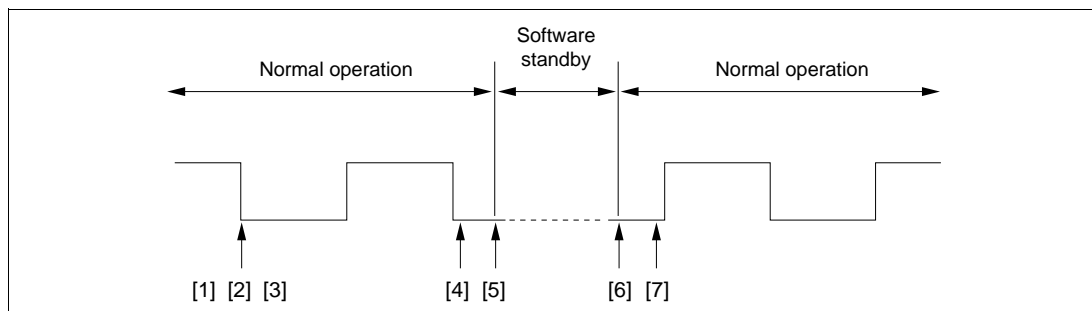
Notes: For block transfer mode, see section 16.4, SCI Interrupts.

\* DMAC and DTC functions are not available in the H8S/2695.

### 17.3.7 Operation in GSM Mode

**Switching the Mode:** When switching between smart card interface mode and software standby mode, the following switching procedure should be followed in order to maintain the clock duty.

- When changing from smart card interface mode to software standby mode
  - [1] Set the data register (DR) and data direction register (DDR) corresponding to the SCK pin to the value for the fixed output state in software standby mode.
  - [2] Write 0 to the TE bit and RE bit in the serial control register (SCR) to halt transmit/receive operation. At the same time, set the CKE1 bit to the value for the fixed output state in software standby mode.
  - [3] Write 0 to the CKE0 bit in SCR to halt the clock.
  - [4] Wait for one serial clock period.  
During this interval, clock output is fixed at the specified level, with the duty preserved.
  - [5] Make the transition to the software standby state.
- When returning to smart card interface mode from software standby mode
  - [6] Exit the software standby state.
  - [7] Write 1 to the CKE0 bit in SCR and output the clock. Signal generation is started with the normal duty.



**Figure 17-9 Clock Halt and Restart Procedure**



**Powering On:** To secure the clock duty from power-on, the following switching procedure should be followed.

- [1] The initial state is port input and high impedance. Use a pull-up resistor or pull-down resistor to fix the potential.
- [2] Fix the SCK pin to the specified output level with the CKE1 bit in SCR.
- [3] Set SMR and SCMR, and switch to smart card mode operation.
- [4] Set the CKE0 bit in SCR to 1 to start clock output.

### **17.3.8 Operation in Block Transfer Mode**

Operation in block transfer mode is the same as in SCI asynchronous mode, except for the following points. For details, see section 16.3.2, Operation in Asynchronous Mode.

#### **(1) Data Format**

The data format is 8 bits with parity. There is no stop bit, but there is a 2-bit (1-bit or more in reception) error guard time.

Also, except during transmission (with start bit, data bits, and parity bit), the transmission pins go to the high-impedance state, so the signal lines must be fixed high with a pull-up resistor.

#### **(2) Transmit/Receive Clock**

Only an internal clock generated by the on-chip baud rate generator can be used as the transmit/receive clock. The number of basic clock periods in a 1-bit transfer interval can be set to 32, 64, 372, or 256 with bits BCP1 and BCP0. For details, see section 17.3.5, Clock.

#### **(3) ERS (FER) Flag**

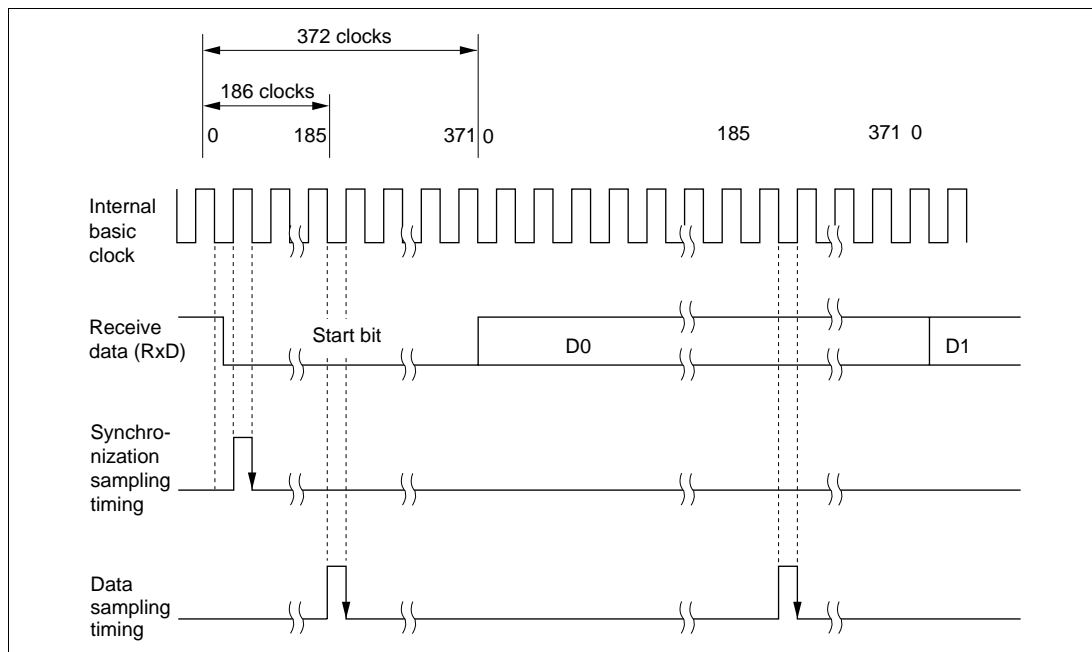
As with the normal Smart Card interface, the ERS flag indicates the error signal status, but since error signal transmission and reception is not performed, this flag is always cleared to 0.

## 17.4 Usage Notes

The following points should be noted when using the SCI as a Smart Card interface.

**Receive Data Sampling Timing and Reception Margin in Smart Card Interface Mode:** In Smart Card interface mode, the SCI operates on a basic clock with a frequency of 32, 64, 372, or 256 times the transfer rate (as determined by bits BCP1 and BCP0).

In reception, the SCI samples the falling edge of the start bit using the basic clock, and performs internal synchronization. Receive data is latched internally at the rising edge of the 16th, 32nd, 186th, or 128th pulse of the basic clock. Figure 17-10 shows the receive data sampling timing when using a clock of 372 times the transfer rate.



**Figure 17-10 Receive Data Sampling Timing in Smart Card Mode  
(Using Clock of 372 Times the Transfer Rate)**

Thus the reception margin in asynchronous mode is given by the following formula.

Formula for reception margin in smart card interface mode

$$M = \left| \left( 0.5 - \frac{1}{2N} \right) - (L - 0.5) F - \frac{|D - 0.5|}{N} (1 + F) \right| \times 100\%$$

Where M: Reception margin (%)

N: Ratio of bit rate to clock (N = 32, 64, 372, and 256)

D: Clock duty (D = 0 to 1.0)

L: Frame length (L = 10)

F: Absolute value of clock frequency deviation

Assuming values of F = 0, D = 0.5 and N = 372 in the above formula, the reception margin formula is as follows.

When D = 0.5 and F = 0,

$$\begin{aligned} M &= (0.5 - 1/2 \times 372) \times 100\% \\ &= 49.866\% \end{aligned}$$

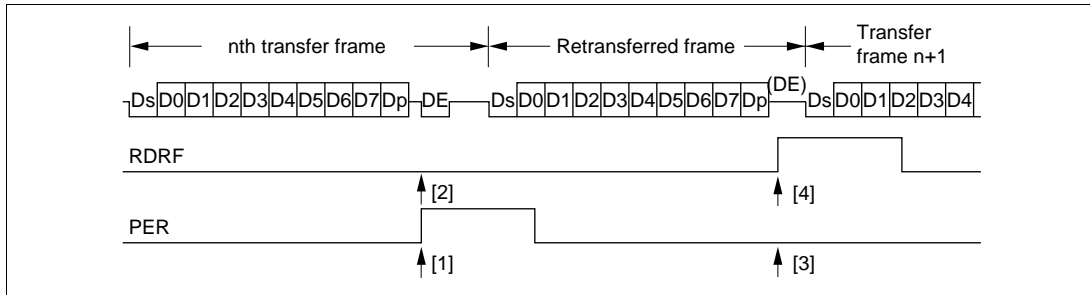
**Retransfer Operations (Except Block Transfer Mode):** Retransfer operations are performed by the SCI in receive mode and transmit mode as described below.

- Retransfer operation when SCI is in receive mode

Figure 17-11 illustrates the retransfer operation when the SCI is in receive mode.

- [1] If an error is found when the received parity bit is checked, the PER bit in SSR is automatically set to 1. If the RIE bit in SCR is enabled at this time, an ERI interrupt request is generated. The PER bit in SSR should be kept cleared to 0 until the next parity bit is sampled.
- [2] The RDRF bit in SSR is not set for a frame in which an error has occurred.
- [3] If no error is found when the received parity bit is checked, the PER bit in SSR is not set to 1.
- [4] If no error is found when the received parity bit is checked, the receive operation is judged to have been completed normally, and the RDRF flag in SSR is automatically set to 1. If the RIE bit in SCR is enabled at this time, an RXI interrupt request is generated.  
If DMAC\* or DTC\* data transfer by an RXI source is enabled, the contents of RDR can be read automatically. When the RDR data is read by the DMAC\* or DTC\*, the RDRF flag is automatically cleared to 0.
- [5] When a normal frame is received, the pin retains the high-impedance state at the timing for error signal transmission.

Note: \* DMAC and DTC functions are not available in the H8S/2695.



**Figure 17-11 Retransfer Operation in SCI Receive Mode**

- Retransfer operation when SCI is in transmit mode

Figure 17-12 illustrates the retransfer operation when the SCI is in transmit mode.

[6] If an error signal is sent back from the receiving end after transmission of one frame is completed, the ERS bit in SSR is set to 1. If the RIE bit in SCR is enabled at this time, an ERI interrupt request is generated. The ERS bit in SSR should be kept cleared to 0 until the next parity bit is sampled.

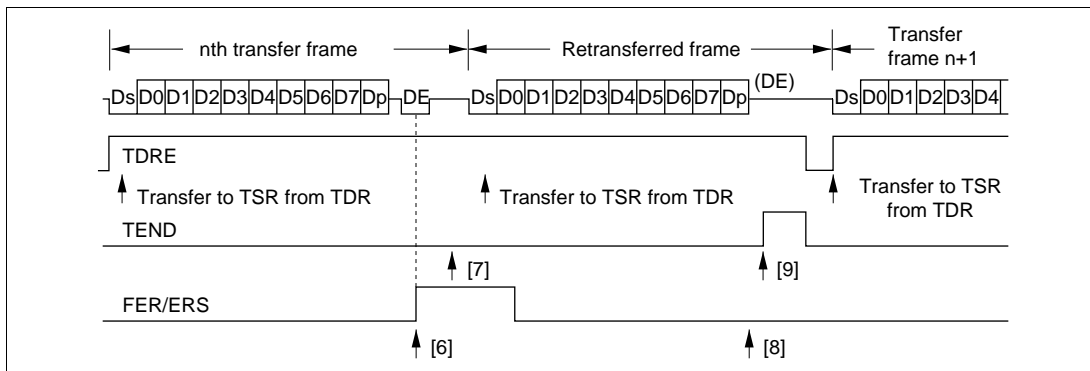
[7] The TEND bit in SSR is not set for a frame for which an error signal indicating an abnormality is received.

[8] If an error signal is not sent back from the receiving end, the ERS bit in SSR is not set.

[9] If an error signal is not sent back from the receiving end, transmission of one frame, including a retransfer, is judged to have been completed, and the TEND bit in SSR is set to 1. If the TIE bit in SCR is enabled at this time, a TXI interrupt request is generated.

If data transfer by the DMAC\* and DTC\* by means of the TXI source is enabled, the next data can be written to TDR automatically. When data is written to TDR by the DMAC\* or DTC\*, the TDRE bit is automatically cleared to 0.

Note: \* DMAC and DTC functions are not available in the H8S/2695.



**Figure 17-12 Retransfer Operation in SCI Transmit Mode**

## Section 18 I<sup>2</sup>C Bus Interface [Option]

(This function is not available in the H8S/2695)

A two-channel I<sup>2</sup>C bus interface is available as an option in the H8S/2633 Series. The I<sup>2</sup>C bus interface is not available for the H8S/2633 Series. Observe the following notes when using this option.

1. For mask-ROM versions, a W is added to the part number in products in which this optional function is used.

Examples: HD6432633WF

2. The product number is identical for F-ZTAT versions. However, be sure to inform your Hitachi sales representative if you will be using this option.

### 18.1 Overview

A two-channel I<sup>2</sup>C bus interface is available for the H8S/2633 Series as an option. The I<sup>2</sup>C bus interface conforms to and provides a subset of the Philips I<sup>2</sup>C bus (inter-IC bus) interface functions. The register configuration that controls the I<sup>2</sup>C bus differs partly from the Philips configuration, however.

Each I<sup>2</sup>C bus interface channel uses only one data line (SDA) and one clock line (SCL) to transfer data, saving board and connector space.

#### 18.1.1 Features

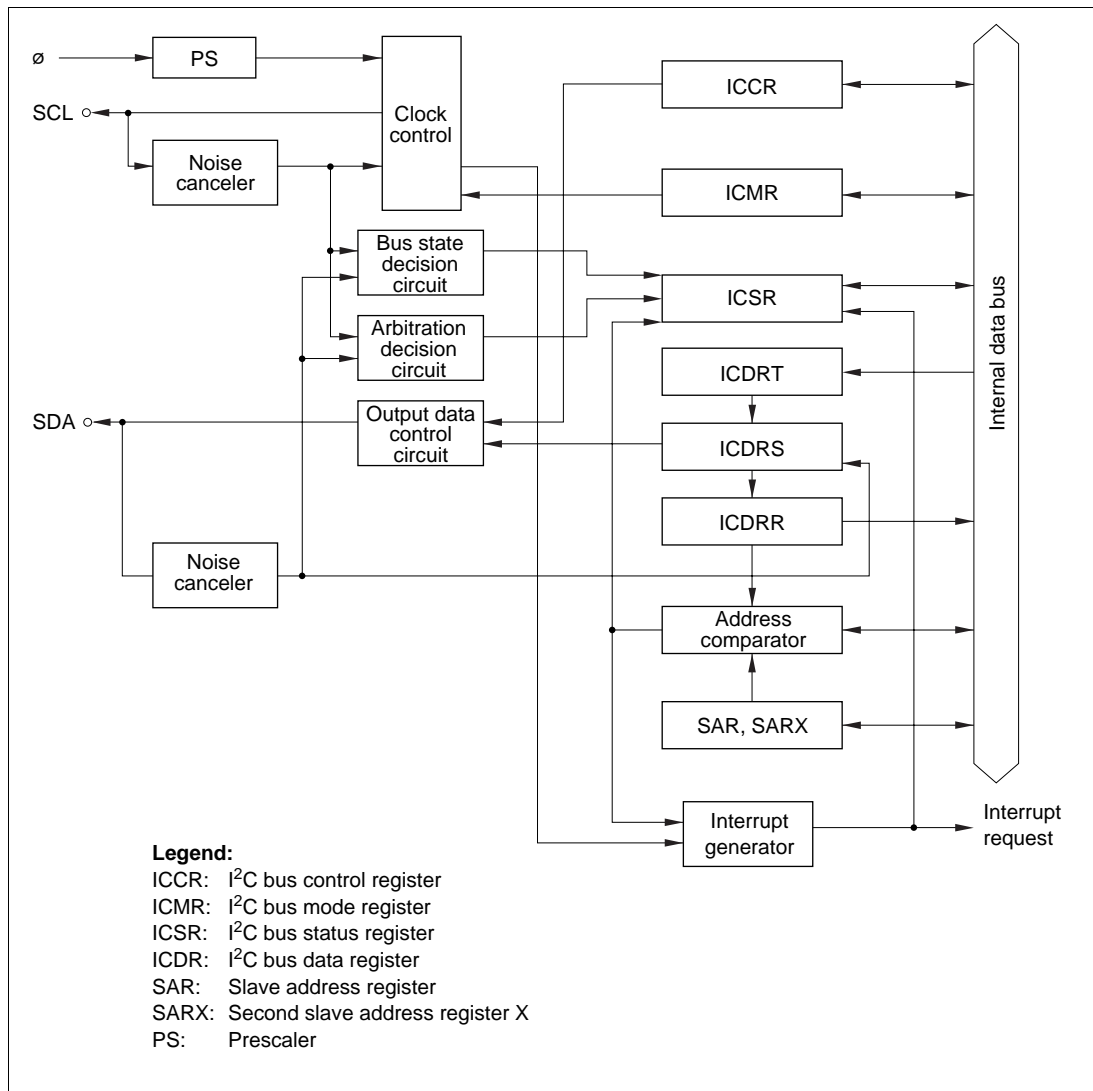
- Selection of addressing format or non-addressing format
  - I<sup>2</sup>C bus format: addressing format with acknowledge bit, for master/slave operation
  - Serial format: non-addressing format without acknowledge bit, for master operation only
- Conforms to Philips I<sup>2</sup>C bus interface (I<sup>2</sup>C bus format)
- Two ways of setting slave address (I<sup>2</sup>C bus format)
- Start and stop conditions generated automatically in master mode (I<sup>2</sup>C bus format)
- Selection of acknowledge output levels when receiving (I<sup>2</sup>C bus format)
- Automatic loading of acknowledge bit when transmitting (I<sup>2</sup>C bus format)

- Wait function in master mode (I<sup>2</sup>C bus format)  
A wait can be inserted by driving the SCL pin low after data transfer, excluding acknowledgement. The wait can be cleared by clearing the interrupt flag.
- Wait function in slave mode (I<sup>2</sup>C bus format)  
A wait request can be generated by driving the SCL pin low after data transfer, excluding acknowledgement. The wait request is cleared when the next transfer becomes possible.
- Three interrupt sources
  - Data transfer end (including transmission mode transition with I<sup>2</sup>C bus format and address reception after loss of master arbitration)
  - Address match: when any slave address matches or the general call address is received in slave receive mode (I<sup>2</sup>C bus format)
  - Stop condition detection
- Selection of 16 internal clocks (in master mode)
- Direct bus drive (with SCL and SDA pins)
  - Two pins—P35/SCL0 and P34/SDA0—(normally NMOS push-pull outputs) function as NMOS open-drain outputs when the bus drive function is selected.
  - Two pins—P33/SCL1 and P32/SDA1—(normally CMOS pins) function as NMOS-only outputs when the bus drive function is selected.

### 18.1.2 Block Diagram

Figure 18-1 shows a block diagram of the I<sup>2</sup>C bus interface.

Figure 18-2 shows an example of I/O pin connections to external circuits. Channel 0 I/O pins are NMOS open drains, and it is possible to apply voltages in excess of the power supply (PV<sub>CC</sub>) voltage for this LSI. Set the upper limit of voltage applied to the power supply (PV<sub>CC</sub>) power supply range + 0.3 V, i.e. 5.8 V. Channel 1 I/O pins are driven solely by NMOS, so in terms of appearance they carry out the same operations as an NMOS open drain. However, the voltage which can be applied to the I/O pins depends on the voltage of the power supply (PV<sub>CC</sub>) of this LSI.



**Figure 18-1 Block Diagram of I<sup>2</sup>C Bus Interface**

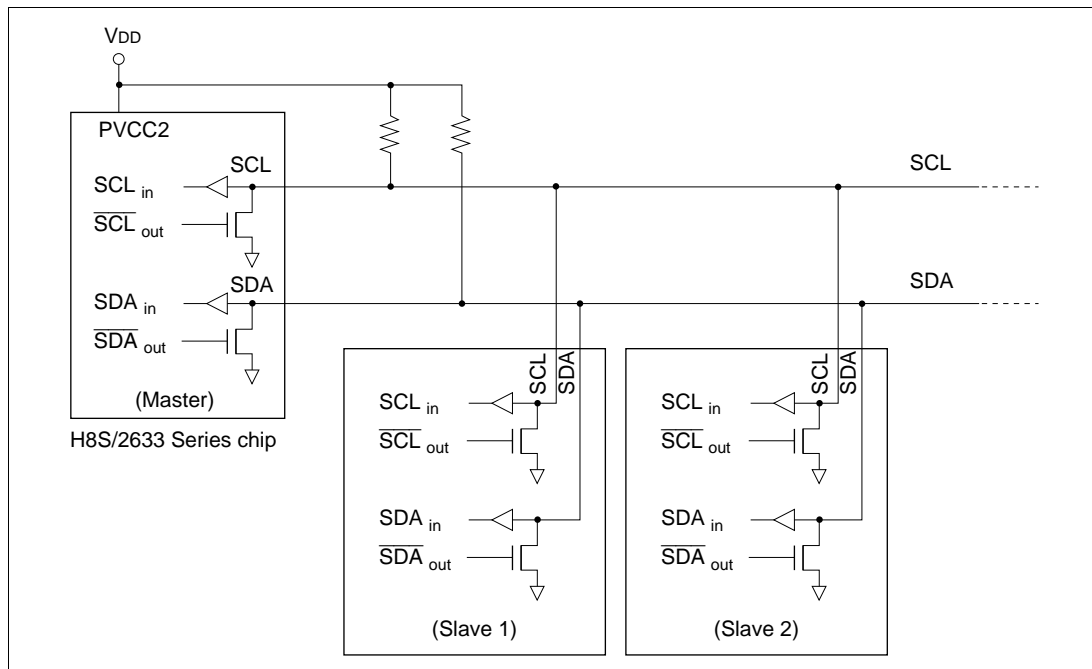


Figure 18-2 I<sup>2</sup>C Bus Interface Connections (Example: H8S/2633 Series Chip as Master)

### 18.1.3 Input/Output Pins

Table 18-1 summarizes the input/output pins used by the I<sup>2</sup>C bus interface.

Table 18-1 I<sup>2</sup>C Bus Interface Pins

Channel	Name	Abbreviation*	I/O	Function
0	Serial clock	SCL0	I/O	IIC0 serial clock input/output
	Serial data	SDA0	I/O	IIC0 serial data input/output
1	Serial clock	SCL1	I/O	IIC1 serial clock input/output
	Serial data	SDA1	I/O	IIC1 serial data input/output

Note: \* In the text, the channel subscript is omitted, and only SCL and SDA are used.



### 18.1.4 Register Configuration

Table 18-2 summarizes the registers of the I<sup>2</sup>C bus interface.

**Table 18-2 Register Configuration**

Channel	Name	Abbreviation	R/W	Initial Value	Address* <sup>1</sup>
0	I <sup>2</sup> C bus control register	ICCR0	R/W	H'01	H'FF78* <sup>3</sup>
	I <sup>2</sup> C bus status register	ICSR0	R/W	H'00	H'FF79* <sup>3</sup>
	I <sup>2</sup> C bus data register	ICDR0	R/W	—	H'FF7E* <sup>2</sup> * <sup>3</sup>
	I <sup>2</sup> C bus mode register	ICMR0	R/W	H'00	H'FF7F* <sup>2</sup> * <sup>3</sup>
	Slave address register	SAR0	R/W	H'00	H'FF7F* <sup>2</sup> * <sup>3</sup>
	Second slave address register	SARX0	R/W	H'01	H'FF7E* <sup>2</sup> * <sup>3</sup>
1	I <sup>2</sup> C bus control register	ICCR1	R/W	H'01	H'FF80* <sup>3</sup>
	I <sup>2</sup> C bus status register	ICSR1	R/W	H'00	H'FF81* <sup>3</sup>
	I <sup>2</sup> C bus data register	ICDR1	R/W	—	H'FF86* <sup>2</sup> * <sup>3</sup>
	I <sup>2</sup> C bus mode register	ICMR1	R/W	H'00	H'FF87* <sup>2</sup> * <sup>3</sup>
	Slave address register	SAR1	R/W	H'00	H'FF87* <sup>2</sup> * <sup>3</sup>
	Second slave address register	SARX1	R/W	H'01	H'FF86* <sup>2</sup> * <sup>3</sup>
Common	Serial control register X	SCRX	R/W	H'00	H'FDB4
	DDC switch register	DDCSWR	R/W	H'0F	H'FDB5
	Module stop control register B	MSTPCRB	R/W	H'FF	H'FDE9

Notes: \*1 Lower 16 bits of the address.

\*2 The register that can be written or read depends on the ICE bit in the I<sup>2</sup>C bus control register. The slave address register can be accessed when ICE = 0, and the I<sup>2</sup>C bus mode register can be accessed when ICE = 1.

\*3 The I<sup>2</sup>C bus interface registers are assigned to the same addresses as other registers. Register selection is performed by means of the IICE bit in the serial control register X (SCRX).

## 18.2 Register Descriptions

### 18.2.1 I<sup>2</sup>C Bus Data Register (ICDR)

Bit	:	7	6	5	4	3	2	1	0
		ICDR7	ICDR6	ICDR5	ICDR4	ICDR3	ICDR2	ICDR1	ICDR0
Initial value	:	—	—	—	—	—	—	—	—
R/W	:	R/W	R/W	R/W	R/W	R/W	R/W	R/W	R/W

- ICDRR

Bit	:	7	6	5	4	3	2	1	0
		ICDRR7	ICDRR6	ICDRR5	ICDRR4	ICDRR3	ICDRR2	ICDRR1	ICDRR0
Initial value	:	—	—	—	—	—	—	—	—
R/W	:	R	R	R	R	R	R	R	R

- ICDS

Bit	:	7	6	5	4	3	2	1	0
		ICDS7	ICDS6	ICDRR5	ICDS4	ICDS3	ICDS2	ICDS1	ICDS0
Initial value	:	—	—	—	—	—	—	—	—
R/W	:	—	—	—	—	—	—	—	—

- ICDRT

Bit	:	7	6	5	4	3	2	1	0
		ICDRT7	ICDRT6	ICDRT5	ICDRT4	ICDRT3	ICDRT2	ICDRT1	ICDRT0
Initial value	:	—	—	—	—	—	—	—	—
R/W	:	W	W	W	W	W	W	W	W

- TDRE, RDRF (internal flags)

Bit	:	—	—
		TDRE	RDRF
Initial value	:	0	0
R/W	:	—	—

ICDR is an 8-bit readable/writable register that is used as a transmit data register when transmitting and a receive data register when receiving. ICDR is divided internally into a shift register (ICDRS), receive buffer (ICDRR), and transmit buffer (ICDRT). ICDRS cannot be read or written by the CPU, ICDRR is read-only, and ICDRT is write-only. Data transfers among the three registers are performed automatically in coordination with changes in the bus state, and affect the status of internal flags such as TDRE and RDRF.

If IIC is in transmit mode and the next data is in ICDRT (the TDRE flag is 0) following transmission/reception of one frame of data using ICDRS, data is transferred automatically from ICDRT to ICDRS. If IIC is in receive mode and no previous data remains in ICDRR (the RDRF flag is 0) following transmission/reception of one frame of data using ICDRS, data is transferred automatically from ICDRS to ICDRR.

If the number of bits in a frame, excluding the acknowledge bit, is less than 8, transmit data and receive data are stored differently. Transmit data should be written justified toward the MSB side when  $MLS = 0$ , and toward the LSB side when  $MLS = 1$ . Receive data bits read from the LSB side should be treated as valid when  $MLS = 0$ , and bits read from the MSB side when  $MLS = 1$ .

ICDR is assigned to the same address as SARX, and can be written and read only when the ICE bit is set to 1 in ICCR.

The value of ICDR is undefined after a reset.

The TDRE and RDRF flags are set and cleared under the conditions shown below. Setting the TDRE and RDRF flags affects the status of the interrupt flags.

<b>TDRE</b>	<b>Description</b>	
0	The next transmit data is in ICDR (ICDRT), or transmission cannot be started [Clearing conditions]	(Initial value)
	<ul style="list-style-type: none"> <li>• When transmit data is written in ICDR (ICDRT) in transmit mode (TRS = 1)</li> <li>• When a stop condition is detected in the bus line state after a stop condition is issued with the I<sup>2</sup>C bus format or serial format selected</li> <li>• When a stop condition is detected with the I<sup>2</sup>C bus format selected</li> <li>• In receive mode (TRS = 0)</li> </ul> (A 0 write to TRS during transfer is valid after reception of a frame containing an acknowledge bit)	
1	The next transmit data can be written in ICDR (ICDRT) [Setting conditions]	
	<ul style="list-style-type: none"> <li>• In transmit mode (TRS = 1), when a start condition is detected in the bus line state after a start condition is issued in master mode with the I<sup>2</sup>C bus format or serial format selected</li> <li>• When using formatless mode in transmit mode (TRS = 1)</li> <li>• When data is transferred from ICDRT to ICDS</li> </ul> (Data transfer from ICDRT to ICDS when TRS = 1 and TDRE = 0, and ICDS is empty)	
	<ul style="list-style-type: none"> <li>• When a switch is made from receive mode (TRS = 0) to transmit mode (TRS = 1) after detection of a start condition</li> </ul>	
<b>RDRF</b>	<b>Description</b>	
0	The data in ICDR (ICDRR) is invalid [Clearing condition]	(Initial value)
	When ICDR (ICDRR) receive data is read in receive mode	
1	The ICDR (ICDRR) receive data can be read [Setting condition]	
	When data is transferred from ICDS to ICDRR (Data transfer from ICDS to ICDRR in case of normal termination with TRS = 0 and RDRF = 0)	

### 18.2.2 Slave Address Register (SAR)

Bit	:	7	6	5	4	3	2	1	0
	:	SVA6	SVA5	SVA4	SVA3	SVA2	SVA1	SVA0	FS
Initial value	:	0	0	0	0	0	0	0	0
R/W	:	R/W	R/W	R/W	R/W	R/W	R/W	R/W	R/W

SAR is an 8-bit readable/writable register that stores the slave address and selects the communication format. When the chip is in slave mode (and the addressing format is selected), if the upper 7 bits of SAR match the upper 7 bits of the first frame received after a start condition, the chip operates as the slave device specified by the master device. SAR is assigned to the same address as ICMR, and can be written and read only when the ICE bit is cleared to 0 in ICCR.

SAR is initialized to H'00 by a reset and in hardware standby mode.

**Bits 7 to 1—Slave Address (SVA6 to SVA0):** Set a unique address in bits SVA6 to SVA0, differing from the addresses of other slave devices connected to the I<sup>2</sup>C bus.

**Bit 0—Format Select (FS):** Used together with the FSX bit in SARX and the SW bit in DDCSWR to select the communication format.

- I<sup>2</sup>C bus format: addressing format with acknowledge bit
- Synchronous serial format: non-addressing format without acknowledge bit, for master mode only

The FS bit also specifies whether or not SAR slave address recognition is performed in slave mode.

DDCSWR Bit 6	SAR Bit 0	SARX Bit 0	Operating Mode
0	0	0	I <sup>2</sup> C bus format <ul style="list-style-type: none"> <li>SAR and SARX slave addresses recognized</li> </ul>
		1	I <sup>2</sup> C bus format (Initial value) <ul style="list-style-type: none"> <li>SAR slave address recognized</li> <li>SARX slave address ignored</li> </ul>
	1	0	I <sup>2</sup> C bus format <ul style="list-style-type: none"> <li>SAR slave address ignored</li> <li>SARX slave address recognized</li> </ul>
		1	Synchronous serial format <ul style="list-style-type: none"> <li>SAR and SARX slave addresses ignored</li> </ul>
1	—	—	Must not be set.

### 18.2.3 Second Slave Address Register (SARX)

Bit	:	7	6	5	4	3	2	1	0
		SVAX6	SVAX5	SVAX4	SVAX3	SVAX2	SVAX1	SVAX0	FSX
Initial value	:	0	0	0	0	0	0	0	1
R/W	:	R/W	R/W	R/W	R/W	R/W	R/W	R/W	R/W

SARX is an 8-bit readable/writable register that stores the second slave address and selects the communication format. When the chip is in slave mode (and the addressing format is selected), if the upper 7 bits of SARX match the upper 7 bits of the first frame received after a start condition, the chip operates as the slave device specified by the master device. SARX is assigned to the same address as ICDR, and can be written and read only when the ICE bit is cleared to 0 in ICCR.

SARX is initialized to H'01 by a reset and in hardware standby mode.

**Bits 7 to 1—Second Slave Address (SVAX6 to SVAX0):** Set a unique address in bits SVAX6 to SVAX0, differing from the addresses of other slave devices connected to the I<sup>2</sup>C bus.

**Bit 0—Format Select X (FSX):** Used together with the FS bit in SAR and the SW bit in DDCSWR to select the communication format.

- I<sup>2</sup>C bus format: addressing format with acknowledge bit
- Synchronous serial format: non-addressing format without acknowledge bit, for master mode only

The FSX bit also specifies whether or not SARX slave address recognition is performed in slave mode. For details, see the description of the FS bit in SAR.

#### 18.2.4 I<sup>2</sup>C Bus Mode Register (ICMR)

Bit	:	7	6	5	4	3	2	1	0
		MLS	WAIT	CKS2	CKS1	CKS0	BC2	BC1	BC0
Initial value	:	0	0	0	0	0	0	0	0
R/W	:	R/W	R/W	R/W	R/W	R/W	R/W	R/W	R/W

ICMR is an 8-bit readable/writable register that selects whether the MSB or LSB is transferred first, performs master mode wait control, and selects the master mode transfer clock frequency and the transfer bit count. ICMR is assigned to the same address as SAR. ICMR can be written and read only when the ICE bit is set to 1 in ICCR.

ICMR is initialized to H'00 by a reset and in hardware standby mode.

**Bit 7—MSB-First/LSB-First Select (MLS):** Selects whether data is transferred MSB-first or LSB-first.

If the number of bits in a frame, excluding the acknowledge bit, is less than 8, transmit data and receive data are stored differently. Transmit data should be written justified toward the MSB side when MLS = 0, and toward the LSB side when MLS = 1. Receive data bits read from the LSB side should be treated as valid when MLS = 0, and bits read from the MSB side when MLS = 1.

Do not set this bit to 1 when the I<sup>2</sup>C bus format is used.

#### Bit 7

MLS	Description
0	MSB-first (Initial value)
1	LSB-first

**Bit 6—Wait Insertion Bit (WAIT):** Selects whether to insert a wait between the transfer of data and the acknowledge bit, in master mode with the I<sup>2</sup>C bus format. When WAIT is set to 1, after the fall of the clock for the final data bit, the IRIC flag is set to 1 in ICCR, and a wait state begins (with SCL at the low level). When the IRIC flag is cleared to 0 in ICCR, the wait ends and the acknowledge bit is transferred. If WAIT is cleared to 0, data and acknowledge bits are transferred consecutively with no wait inserted.

The IRIC flag in ICCR is set to 1 on completion of the acknowledge bit transfer, regardless of the WAIT setting.

The setting of this bit is invalid in slave mode.

**Bit 6**

<b>WAIT</b>	<b>Description</b>	
0	Data and acknowledge bits transferred consecutively	(Initial value)
1	Wait inserted between data and acknowledge bits	



**Bits 5 to 3—Serial Clock Select (CKS2 to CKS0):** These bits, together with the IICX1 (channel 1) or IICX0 (channel 0) bit in the SCRX register, select the serial clock frequency in master mode. They should be set according to the required transfer rate.

SCRX				Transfer Rate								
Bit 5 or 6				Bit 5	Bit 4	Bit 3						
IICX	CKS2	CKS1	CKS0	Clock	$\phi =$ 5 MHz	$\phi =$ 8 MHz	$\phi =$ 10 MHz	$\phi =$ 16 MHz	$\phi =$ 20 MHz	$\phi =$ 25 MHz	$\phi =$ 28 MHz	
0	0	0	0	$\phi/28$	179 kHz	286 kHz	357 kHz	571 kHz*	714 kHz*	893 kHz*	1000 kHz*	
			1	$\phi/40$	125 kHz	200 kHz	250 kHz	400 kHz	500 kHz*	625 kHz*	700 kHz*	
		1	0	$\phi/48$	104 kHz	167 kHz	208 kHz	333 kHz	417 kHz*	521 kHz*	583 kHz*	
			1	$\phi/64$	78.1 kHz	125 kHz	156 kHz	250 kHz	313 kHz	391 kHz	438 kHz*	
	1	0	0	$\phi/80$	62.5 kHz	100 kHz	125 kHz	200 kHz	250 kHz	313 kHz	350 kHz	
			1	$\phi/100$	50.0 kHz	80.0 kHz	100 kHz	160 kHz	200 kHz	250 kHz	280 kHz	
		1	0	$\phi/112$	44.6 kHz	71.4 kHz	89.3 kHz	143 kHz	179 kHz	223 kHz	250 kHz	
			1	$\phi/128$	39.1 kHz	62.5 kHz	78.1 kHz	125 kHz	156 kHz	195 kHz	219 kHz	
1	0	0	0	$\phi/56$	89.3 kHz	143 kHz	179 kHz	286 kHz	357 kHz	446 kHz*	500 kHz*	
			1	$\phi/80$	62.5 kHz	100 kHz	125 kHz	200 kHz	250 kHz	313 kHz	350 kHz	
		1	0	$\phi/96$	52.1 kHz	83.3 kHz	104 kHz	167 kHz	208 kHz	260 kHz	292 kHz	
			1	$\phi/128$	39.1 kHz	62.5 kHz	78.1 kHz	125 kHz	156 kHz	195 kHz	219 kHz	
	1	0	0	$\phi/160$	31.3 kHz	50.0 kHz	62.5 kHz	100 kHz	125 kHz	156 kHz	175 kHz	
			1	$\phi/200$	25.0 kHz	40.0 kHz	50.0 kHz	80.0 kHz	100 kHz	125 kHz	140 kHz	
		1	0	$\phi/224$	22.3 kHz	35.7 kHz	44.6 kHz	71.4 kHz	89.3 kHz	112 kHz	125 kHz	
			1	$\phi/256$	19.5 kHz	31.3 kHz	39.1 kHz	62.5 kHz	78.1 kHz	97.7 kHz	109 kHz	

Note: \* These rates are outside the ranges stipulated in the I<sup>2</sup>C bus interface specifications (normal mode: max. 100 kHz, high-speed mode: max. 400 kHz).

**Bits 2 to 0—Bit Counter (BC2 to BC0):** Bits BC2 to BC0 specify the number of bits to be transferred next. With the I<sup>2</sup>C bus format (when the FS bit in SAR or the FSX bit in SARX is 0), the data is transferred with one additional acknowledge bit. Bit BC2 to BC0 settings should be made during an interval between transfer frames. If bits BC2 to BC0 are set to a value other than 000, the setting should be made while the SCL line is low.

The bit counter is initialized to 000 by a reset and when a start condition is detected. The value returns to 000 at the end of a data transfer, including the acknowledge bit.

Bit 2	Bit 1	Bit 0	Bits/Frame	
BC2	BC1	BC0	Synchronous Serial Format	I <sup>2</sup> C Bus Format
0	0	0	8	9 (Initial value)
		1	1	2
	1	0	2	3
1	0	1	3	4
		0	4	5
	1	5	6	
	1	0	6	7
	1	1	7	8

### 18.2.5 I<sup>2</sup>C Bus Control Register (ICCR)

Bit	:	7	6	5	4	3	2	1	0
		ICE	IEIC	MST	TRS	ACKE	BBSY	IRIC	SCP
Initial value	:	0	0	0	0	0	0	0	1
R/W	:	R/W	R/W	R/W	R/W	R/W	R/W	R/(W)*	W

Note: \* Only 0 can be written, for flag clearing.

ICCR is an 8-bit readable/writable register that enables or disables the I<sup>2</sup>C bus interface, enables or disables interrupts, selects master or slave mode and transmission or reception, enables or disables acknowledgement, confirms the I<sup>2</sup>C bus interface bus status, issues start/stop conditions, and performs interrupt flag confirmation.

ICCR is initialized to H'01 by a reset and in hardware standby mode.

**Bit 7—I<sup>2</sup>C Bus Interface Enable (ICE):** Selects whether or not the I<sup>2</sup>C bus interface is to be used. When ICE is set to 1, port pins function as SCL and SDA input/output pins and transfer operations are enabled. When ICE is cleared to 0, the I<sup>2</sup>C bus interface module is halted and its internal states are cleared.

The SAR and SARX registers can be accessed when ICE is 0. The ICMR and ICDR registers can be accessed when ICE is 1.

**Bit 7**

ICE	Description
0	I <sup>2</sup> C bus interface module disabled, with SCL and SDA signal pins set to port function I <sup>2</sup> C bus interface module internal states initialized SAR and SARX can be accessed
1	I <sup>2</sup> C bus interface module enabled for transfer operations (pins SCL and SCA are driving the bus) ICMR and ICDR can be accessed

**Bit 6—I<sup>2</sup>C Bus Interface Interrupt Enable (IEIC):** Enables or disables interrupts from the I<sup>2</sup>C bus interface to the CPU.

**Bit 6**

IEIC	Description
0	Interrupts disabled (Initial value)
1	Interrupts enabled

**Bit 5—Master/Slave Select (MST)**

**Bit 4—Transmit/Receive Select (TRS)**

MST selects whether the I<sup>2</sup>C bus interface operates in master mode or slave mode.

TRS selects whether the I<sup>2</sup>C bus interface operates in transmit mode or receive mode.

In master mode with the I<sup>2</sup>C bus format, when arbitration is lost, MST and TRS are both reset by hardware, causing a transition to slave receive mode. In slave receive mode with the addressing format (FS = 0 or FSX = 0), hardware automatically selects transmit or receive mode according to the R/W bit in the first frame after a start condition.

Modification of the TRS bit during transfer is deferred until transfer of the frame containing the acknowledge bit is completed, and the changeover is made after completion of the transfer.

MST and TRS select the operating mode as follows.

<b>Bit 5</b>		<b>Bit 4</b>	
<b>MST</b>	<b>TRS</b>	<b>Operating Mode</b>	
0	0	Slave receive mode	(Initial value)
	1	Slave transmit mode	
1	0	Master receive mode	
	1	Master transmit mode	

<b>Bit 5</b>	
<b>MST</b>	<b>Description</b>
0	Slave mode [Clearing conditions] 1. When 0 is written by software 2. When bus arbitration is lost after transmission is started in I <sup>2</sup> C bus format master mode
1	Master mode [Setting conditions] 1. When 1 is written by software (in cases other than clearing condition 2) 2. When 1 is written in MST after reading MST = 0 (in case of clearing condition 2)

<b>Bit 4</b>	
<b>TRS</b>	<b>Description</b>
0	Receive mode [Clearing conditions] 1. When 0 is written by software (in cases other than setting condition 3) 2. When 0 is written in TRS after reading TRS = 1 (in case of clearing condition 3) 3. When bus arbitration is lost after transmission is started in I <sup>2</sup> C bus format master mode 4. When the SW bit in DDSCSWR changes from 1 to 0
1	Transmit mode [Setting conditions] 1. When 1 is written by software (in cases other than clearing conditions 3 and 4) 2. When 1 is written in TRS after reading TRS = 0 (in case of clearing conditions 3 and 4) 3. When 1 is received as the R/W bit of the first frame in I <sup>2</sup> C bus format slave mode

**Bit 3—Acknowledge Bit Judgement Selection (ACKE):** Specifies whether the value of the acknowledge bit returned from the receiving device when using the I<sup>2</sup>C bus format is to be ignored and continuous transfer is performed, or transfer is to be aborted and error handling, etc., performed if the acknowledge bit is 1. When the ACKE bit is 0, the value of the received acknowledge bit is not indicated by the ACKB bit, which is always 0.

In the H8S/2633 Series, the DTC\* can be used to perform continuous transfer. The DTC\* is activated when the IRTR interrupt flag is set to 1 (IRTR is one of two interrupt flags, the other being IRIC). When the ACKE bit is 0, the TDRE, IRIC, and IRTR flags are set on completion of data transmission, regardless of the value of the acknowledge bit. When the ACKE bit is 1, the TDRE, IRIC, and IRTR flags are set on completion of data transmission when the acknowledge bit is 0, and the IRIC flag alone is set on completion of data transmission when the acknowledge bit is 1.

When the DTC\* is activated, the TDRE, IRIC, and IRTR flags are cleared to 0 after the specified number of data transfers have been executed. Consequently, interrupts are not generated during continuous data transfer, but if data transmission is completed with a 1 acknowledge bit when the ACKE bit is set to 1, the DTC\* is not activated and an interrupt is generated, if enabled.

Depending on the receiving device, the acknowledge bit may be significant, in indicating completion of processing of the received data, for instance, or may be fixed at 1 and have no significance.

Note: \* The DTC function is not available in the H8S/2695.

### Bit 3

ACKE	Description
0	The value of the acknowledge bit is ignored, and continuous transfer is performed (Initial value)
1	If the acknowledge bit is 1, continuous transfer is interrupted

**Bit 2—Bus Busy (BBSY):** The BBSY flag can be read to check whether the I<sup>2</sup>C bus (SCL, SDA) is busy or free. In master mode, this bit is also used to issue start and stop conditions.

A high-to-low transition of SDA while SCL is high is recognized as a start condition, setting BBSY to 1. A low-to-high transition of SDA while SCL is high is recognized as a stop condition, clearing BBSY to 0.

To issue a start condition, use a MOV instruction to write 1 in BBSY and 0 in SCP. A retransmit start condition is issued in the same way. To issue a stop condition, use a MOV instruction to write 0 in BBSY and 0 in SCP. It is not possible to write to BBSY in slave mode; the I<sup>2</sup>C bus interface must be set to master transmit mode before issuing a start condition. MST and TRS should both be set to 1 before writing 1 in BBSY and 0 in SCP.

**Bit 2**

<b>BBSY</b>	<b>Description</b>
0	Bus is free [Clearing condition] When a stop condition is detected
1	Bus is busy [Setting condition] When a start condition is detected

**Bit 1—I<sup>2</sup>C Bus Interface Interrupt Request Flag (IRIC):** Indicates that the I<sup>2</sup>C bus interface has issued an interrupt request to the CPU. IRIC is set to 1 at the end of a data transfer, when a slave address or general call address is detected in slave receive mode, when bus arbitration is lost in master transmit mode, and when a stop condition is detected. IRIC is set at different times depending on the FS bit in SAR and the WAIT bit in ICMR. See section 18.3.7, IRIC Setting Timing and SCL Control. The conditions under which IRIC is set also differ depending on the setting of the ACKE bit in ICCR.

IRIC is cleared by reading IRIC after it has been set to 1, then writing 0 in IRIC.

When the DTC\* is used, IRIC is cleared automatically and transfer can be performed continuously without CPU intervention.

Note: \* The DTC function is not available in the H8S/2695.

**Bit 1**

<b>IRIC</b>	<b>Description</b>
0	<p>Waiting for transfer, or transfer in progress (Initial value)</p> <p>[Clearing conditions]</p> <ol style="list-style-type: none"> <li>When 0 is written in IRIC after reading IRIC = 1</li> <li>When ICDR is written or read by the DTC* (When the TDRE or RDRF flag is cleared to 0) (This is not always a clearing condition; see the description of DTC* operation for details)</li> </ol>
1	<p>Interrupt requested</p> <p>[Setting conditions]</p> <ul style="list-style-type: none"> <li>I<sup>2</sup>C bus format master mode <ol style="list-style-type: none"> <li>When a start condition is detected in the bus line state after a start condition is issued (when the TDRE flag is set to 1 because of first frame transmission)</li> <li>When a wait is inserted between the data and acknowledge bit when WAIT = 1</li> <li>At the end of data transfer (at the rise of the 9th transmit/receive clock pulse, or at the fall of the 8th transmit/receive clock pulse when using wait insertion)</li> <li>When a slave address is received after bus arbitration is lost (when the AL flag is set to 1)</li> <li>When 1 is received as the acknowledge bit when the ACKE bit is 1 (when the ACKB bit is set to 1)</li> </ol> </li> <li>I<sup>2</sup>C bus format slave mode <ol style="list-style-type: none"> <li>When the slave address (SVA, SVAX) matches (when the AAS and AASX flags are set to 1) and at the end of data transfer up to the subsequent retransmission start condition or stop condition detection (when the TDRE or RDRF flag is set to 1)</li> <li>When the general call address is detected (when FS = 0 and the ADZ flag is set to 1) and at the end of data transfer up to the subsequent retransmission start condition or stop condition detection (when the TDRE or RDRF flag is set to 1)</li> <li>When 1 is received as the acknowledge bit when the ACKE bit is 1 (when the ACKB bit is set to 1)</li> <li>When a stop condition is detected (when the STOP or ESTP flag is set to 1)</li> </ol> </li> <li>Synchronous serial format <ol style="list-style-type: none"> <li>At the end of data transfer (when the TDRE or RDRF flag is set to 1)</li> <li>When a start condition is detected with serial format selected</li> </ol> </li> </ul> <p>When any other condition arises in which the TDRE or RDRF flag is set to 1</p>

Note: \* The DTC function is not available in the H8S/2695.

When, with the I<sup>2</sup>C bus format selected, IRIC is set to 1 and an interrupt is generated, other flags must be checked in order to identify the source that set IRIC to 1. Although each source has a corresponding flag, caution is needed at the end of a transfer.

When the TDRE or RDRF internal flag is set, the readable IRTR flag may or may not be set. The IRTR flag (the DTC start request flag) is not set at the end of a data transfer up to detection of a retransmission start condition or stop condition after a slave address (SVA) or general call address match in I<sup>2</sup>C bus format slave mode.

Even when the IRIC flag and IRTR flag are set, the TDRE or RDRF internal flag may not be set. The IRIC and IRTR flags are not cleared at the end of the specified number of transfers in continuous transfer using the DTC\*. The TDRE or RDRF flag is cleared, however, since the specified number of ICDR reads or writes have been completed.

Table 18-3 shows the relationship between the flags and the transfer states.

Note: \* The DTC function is not available in the H8S/2695.

**Table 18-3 Flags and Transfer States**

MST	TRS	BBSY	ESTP	STOP	IRTR	AASX	AL	AAS	ADZ	ACKB	State
1/0	1/0	0	0	0	0	0	0	0	0	0	Idle state (flag clearing required)
1	1	0	0	0	0	0	0	0	0	0	Start condition issuance
1	1	1	0	0	1	0	0	0	0	0	Start condition established
1	1/0	1	0	0	0	0	0	0	0	0/1	Master mode wait
1	1/0	1	0	0	1	0	0	0	0	0/1	Master mode transmit/receive end
0	0	1	0	0	0	1/0	1	1/0	1/0	0	Arbitration lost
0	0	1	0	0	0	0	0	1	0	0	SAR match by first frame in slave mode
0	0	1	0	0	0	0	0	1	1	0	General call address match
0	0	1	0	0	0	1	0	0	0	0	SARX match
0	1/0	1	0	0	0	0	0	0	0	0/1	Slave mode transmit/receive end (except after SARX match)
0	1/0	1	0	0	1	1	0	0	0	0	Slave mode transmit/receive end (after SARX match)
0	1/0	0	1/0	1/0	0	0	0	0	0	0/1	Stop condition detected



**Bit 0—Start Condition/Stop Condition Prohibit (SCP):** Controls the issuing of start and stop conditions in master mode. To issue a start condition, write 1 in BBSY and 0 in SCP. A retransmit start condition is issued in the same way. To issue a stop condition, write 0 in BBSY and 0 in SCP. This bit is always read as 1. If 1 is written, the data is not stored.

**Bit 0**

SCP	Description
0	Writing 0 issues a start or stop condition, in combination with the BBSY flag
1	Reading always returns a value of 1 (Initial value) Writing is ignored

**18.2.6 I<sup>2</sup>C Bus Status Register (ICSR)**

Bit	:	7	6	5	4	3	2	1	0
		ESTP	STOP	IRTR	AASX	AL	AAS	ADZ	ACKB
Initial value	:	0	0	0	0	0	0	0	0
R/W	:	R/(W)*	R/(W)*	R/(W)*	R/(W)*	R/(W)*	R/(W)*	R/(W)*	R/W

Note: \* Only 0 can be written, for flag clearing.

ICSR is an 8-bit readable/writable register that performs flag confirmation and acknowledge confirmation and control.

ICSR is initialized to H'00 by a reset and in hardware standby mode.

**Bit 7—Error Stop Condition Detection Flag (ESTP):** Indicates that a stop condition has been detected during frame transfer in I<sup>2</sup>C bus format slave mode.

**Bit 7**

ESTP	Description
0	No error stop condition (Initial value) [Clearing conditions] 1. When 0 is written in ESTP after reading ESTP = 1 2. When the IRIC flag is cleared to 0
1	<ul style="list-style-type: none"> <li>In I<sup>2</sup>C bus format slave mode Error stop condition detected [Setting condition] When a stop condition is detected during frame transfer</li> <li>In other modes No meaning</li> </ul>

**Bit 6—Normal Stop Condition Detection Flag (STOP):** Indicates that a stop condition has been detected after completion of frame transfer in I<sup>2</sup>C bus format slave mode.

**Bit 6**

STOP	Description
0	No normal stop condition (Initial value) [Clearing conditions] 1. When 0 is written in STOP after reading STOP = 1 2. When the IRIC flag is cleared to 0
1	<ul style="list-style-type: none"> <li>In I<sup>2</sup>C bus format slave mode Normal stop condition detected [Setting condition] When a stop condition is detected after completion of frame transfer</li> <li>In other modes No meaning</li> </ul>

**Bit 5—I<sup>2</sup>C Bus Interface Continuous Transmission/Reception Interrupt Request Flag (IRTR):** Indicates that the I<sup>2</sup>C bus interface has issued an interrupt request to the CPU, and the source is completion of reception/transmission of one frame in continuous transmission/reception for which DTC\* activation is possible. When the IRTR flag is set to 1, the IRIC flag is also set to 1 at the same time.

IRTR flag setting is performed when the TDRE or RDRF flag is set to 1. IRTR is cleared by reading IRTR after it has been set to 1, then writing 0 in IRTR. IRTR is also cleared automatically when the IRIC flag is cleared to 0.

#### Bit 5

IRTR	Description
0	Waiting for transfer, or transfer in progress (Initial value) [Clearing conditions] 1. When 0 is written in IRTR after reading IRTR = 1 2. When the IRIC flag is cleared to 0
1	Continuous transfer state [Setting conditions] • In I <sup>2</sup> C bus interface slave mode When the TDRE or RDRF flag is set to 1 when AASX = 1 • In other modes When the TDRE or RDRF flag is set to 1

Note: \* The DTC function is not available in the H8S/2695.

**Bit 4—Second Slave Address Recognition Flag (AASX):** In I<sup>2</sup>C bus format slave receive mode, this flag is set to 1 if the first frame following a start condition matches bits SVAX6 to SVAX0 in SARX.

AASX is cleared by reading AASX after it has been set to 1, then writing 0 in AASX. AASX is also cleared automatically when a start condition is detected.

#### Bit 4

AASX	Description
0	Second slave address not recognized (Initial value) [Clearing conditions] 1. When 0 is written in AASX after reading AASX = 1 2. When a start condition is detected 3. In master mode
1	Second slave address recognized [Setting condition] When the second slave address is detected in slave receive mode and FSX = 0

**Bit 3—Arbitration Lost (AL):** This flag indicates that arbitration was lost in master mode. The I<sup>2</sup>C bus interface monitors the bus. When two or more master devices attempt to seize the bus at nearly the same time, if the I<sup>2</sup>C bus interface detects data differing from the data it sent, it sets AL to 1 to indicate that the bus has been taken by another master.

AL is cleared by reading AL after it has been set to 1, then writing 0 in AL. In addition, AL is reset automatically by write access to ICDR in transmit mode, or read access to ICDR in receive mode.

**Bit 3**

AL	Description
0	Bus arbitration won (Initial value) [Clearing conditions] 1. When ICDR data is written (transmit mode) or read (receive mode) 2. When 0 is written in AL after reading AL = 1
1	Arbitration lost [Setting conditions] 1. If the internal SDA and SDA pin disagree at the rise of SCL in master transmit mode 2. If the internal SCL line is high at the fall of SCL in master transmit mode

**Bit 2—Slave Address Recognition Flag (AAS):** In I<sup>2</sup>C bus format slave receive mode, this flag is set to 1 if the first frame following a start condition matches bits SVA6 to SVA0 in SAR, or if the general call address (H'00) is detected.

AAS is cleared by reading AAS after it has been set to 1, then writing 0 in AAS. In addition, AAS is reset automatically by write access to ICDR in transmit mode, or read access to ICDR in receive mode.

**Bit 2**

AAS	Description
0	Slave address or general call address not recognized (Initial value) [Clearing conditions] 1. When ICDR data is written (transmit mode) or read (receive mode) 2. When 0 is written in AAS after reading AAS = 1 3. In master mode
1	Slave address or general call address recognized [Setting condition] When the slave address or general call address is detected in slave receive mode and FS = 0

**Bit 1—General Call Address Recognition Flag (ADZ):** In I<sup>2</sup>C bus format slave receive mode, this flag is set to 1 if the first frame following a start condition is the general call address (H'00).

ADZ is cleared by reading ADZ after it has been set to 1, then writing 0 in ADZ. In addition, ADZ is reset automatically by write access to ICDR in transmit mode, or read access to ICDR in receive mode.

**Bit 1**

ADZ	Description
0	General call address not recognized (Initial value) [Clearing conditions] 1. When ICDR data is written (transmit mode) or read (receive mode) 2. When 0 is written in ADZ after reading ADZ = 1 3. In master mode
1	General call address recognized [Setting condition] When the general call address is detected in slave receive mode and (FSX = 0 or FS = 0)

**Bit 0—Acknowledge Bit (ACKB):** Stores acknowledge data. In transmit mode, after the receiving device receives data, it returns acknowledge data, and this data is loaded into ACKB. In receive mode, after data has been received, the acknowledge data set in this bit is sent to the transmitting device.

When this bit is read, in transmission (when TRS = 1), the value loaded from the bus line (returned by the receiving device) is read. In reception (when TRS = 0), the value set by internal software is read.

**Bit 0**

ACKB	Description
0	Receive mode: 0 is output at acknowledge output timing (Initial value) Transmit mode: Indicates that the receiving device has acknowledged the data (signal is 0)
1	Receive mode: 1 is output at acknowledge output timing Transmit mode: Indicates that the receiving device has not acknowledged the data (signal is 1)

### 18.2.7 Serial Control Register X (SCRX)

Bit	:	7	6	5	4	3	2	1	0
		—	IICX1	IICX0	IICE	FLSHE	—	—	—
Initial value	:	0	0	0	0	0	0	0	0
R/W	:	R/W	R/W	R/W	R/W	R/W	R/W	R/W	R/W

SCRX is an 8-bit readable/writable register that controls register access, the I<sup>2</sup>C interface operating mode (when the on-chip IIC option is included), and on-chip flash memory control (F-ZTAT versions). If a module controlled by SCRX is not used, do not write 1 to the corresponding bit.

SCRX is initialized to H'00 by a reset and in hardware standby mode.

**Bit 7—Reserved:** Do not set 1.

**Bits 6 and 5—I<sup>2</sup>C Transfer Select 1 and 0 (IICX1 and IICX0):** These bits, together with bits CKS2 to CKS0 in ICMR of IIC1 and IIC0, select the transfer rate in master mode. For details, see section 18.2.4, I<sup>2</sup>C Bus Mode Register (ICMR).

**Bit 4—I<sup>2</sup>C Master Enable (IICE):** Controls CPU access to the I<sup>2</sup>C bus interface data and control registers (ICCR, ICSR, ICDR/SARX, and ICMR/SAR).

#### Bit 4

IICE	Description
0	CPU access to I <sup>2</sup> C bus interface data and control registers is disabled (Initial value)
1	CPU access to I <sup>2</sup> C bus interface data and control registers is enabled

**Bit 3—Flash Memory Control Register Enable (FLSHE):** Controls the operation of the flash memory in F-ZTAT versions. For details, see section 22, ROM.

**Bits 2 to 0—Reserved:** Do not set 1.

## 18.2.8 DDC Switch Register (DDCSWR)

Bit	:	7	6	5	4	3	2	1	0
		—	—	—	—	CLR3	CLR2	CLR1	CLR0
Initial value	:	0	0	0	0	1	1	1	1
R/W	:	R/(W)*1	R/(W)*1	R/(W)*1	R/(W)*1	W*2	W*2	W*2	W*2

Notes: \*1 Should always be written with 0.  
\*2 Always read as 1.

DDCSWR is an 8-bit readable/writable register that is used to initialize the IIC module.

DDCSWR is initialized to H'0F by a reset and in hardware standby mode.

**Bits 7 to 4—Reserved:** Should always be written with 0.

**Bits 3 to 0—IIC Clear 3 to 0 (CLR3 to CLR0):** These bits control initialization of the internal state of IIC0 and IIC1.

These bits can only be written to; if read they will always return a value of 1.

When a write operation is performed on these bits, a clear signal is generated for the internal latch circuit of the corresponding module(s), and the internal state of the IIC module(s) is initialized.

The write data for these bits is not retained. To perform IIC clearance, bits CLR3 to CLR0 must be written to simultaneously using an MOV instruction. Do not use a bit manipulation instruction such as BCLR.

When clearing is required again, all the bits must be written to in accordance with the setting.

Bit 3	Bit 2	Bit 1	Bit 0	Description
CLR3	CLR2	CLR1	CLR0	
0	0	—	—	Setting prohibited
	1	0	0	Setting prohibited
			1	IIC0 internal latch cleared
		1	0	IIC1 internal latch cleared
			1	IIC0 and IIC1 internal latches cleared
1	—	—	—	Invalid setting

### 18.2.9 Module Stop Control Register B (MSTPCRB)

Bit	:	7	6	5	4	3	2	1	0
		MSTPB7	MSTPB6	MSTPB5	MSTPB4	MSTPB3	MSTPB2	MSTPB1	MSTPB0
Initial value	:	1	1	1	1	1	1	1	1
R/W	:	R/W	R/W	R/W	R/W	R/W	R/W	R/W	R/W

MSTPCRB is an 8-bit readable/writable register that perform module stop mode control.

When the MSTPB4 or MSTPB3 bit is set to 1, operation of the corresponding IIC channel is halted at the end of the bus cycle, and a transition is made to module stop mode. For details, see section 24.5, Module Stop Mode.

MSTPCRB is initialized to H'FF by a power-on reset and in hardware standby mode. It is not initialized by a manual reset and in software standby mode.

**Bit 4—Module Stop (MSTPB4):** Specifies IIC channel 0 module stop mode.

#### Bit 4

MSTPB4	Description
0	IIC channel 0 module stop mode is cleared
1	IIC channel 0 module stop mode is set (Initial value)

**Bit 3—Module Stop (MSTPB3):** Specifies IIC channel 1 module stop mode.

#### Bit 3

MSTPB3	Description
0	IIC channel 1 module stop mode is cleared
1	IIC channel 1 module stop mode is set (Initial value)



## 18.3 Operation

### 18.3.1 I<sup>2</sup>C Bus Data Format

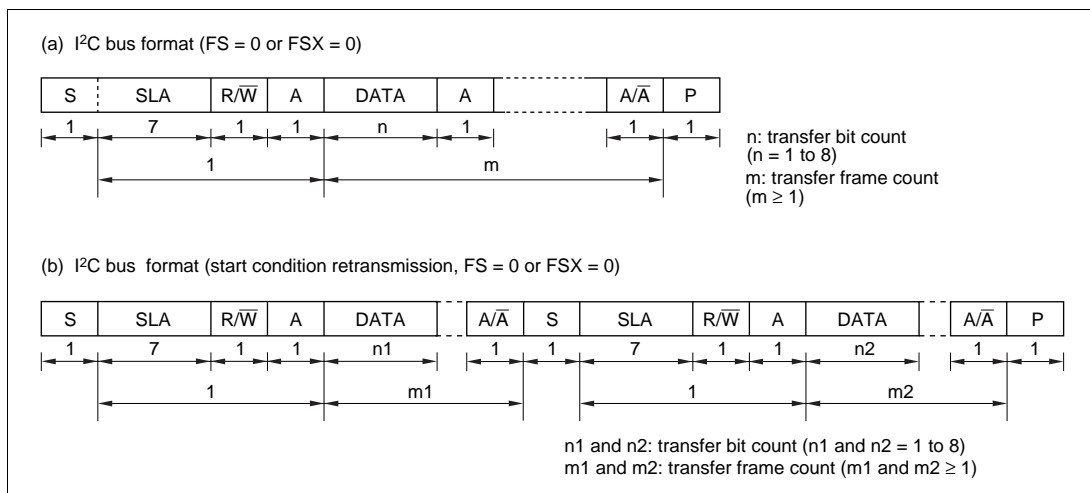
The I<sup>2</sup>C bus interface has serial and I<sup>2</sup>C bus formats.

The I<sup>2</sup>C bus formats are addressing formats with an acknowledge bit. These are shown in figures 18-3 (a) and (b). The first frame following a start condition always consists of 8 bits.

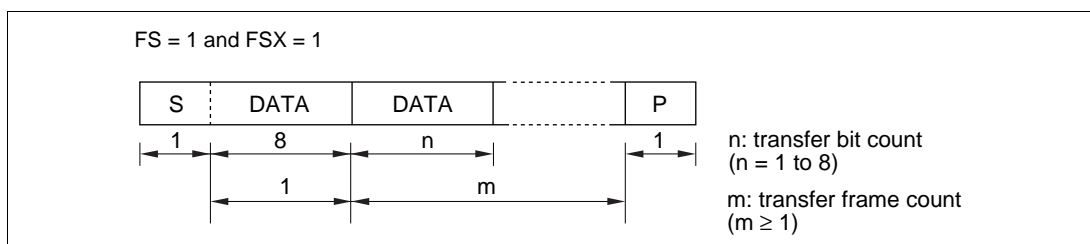
The serial format is a non-addressing format with no acknowledge bit. Although start and stop conditions must be issued, this format can be used as a synchronous serial format. This is shown in figure 18-4.

Figure 18-5 shows the I<sup>2</sup>C bus timing.

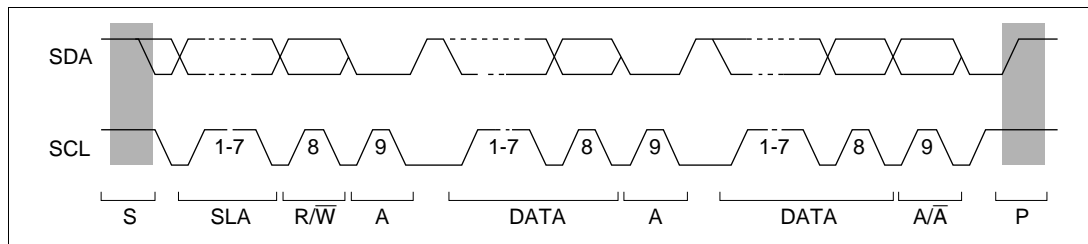
The symbols used in figures 18-3 to 18-5 are explained in table 18-4.



**Figure 18-3 I<sup>2</sup>C Bus Data Formats (I<sup>2</sup>C Bus Formats)**



**Figure 18-4 I<sup>2</sup>C Bus Data Format (Serial Format)**



**Figure 18-5 I<sup>2</sup>C Bus Timing**

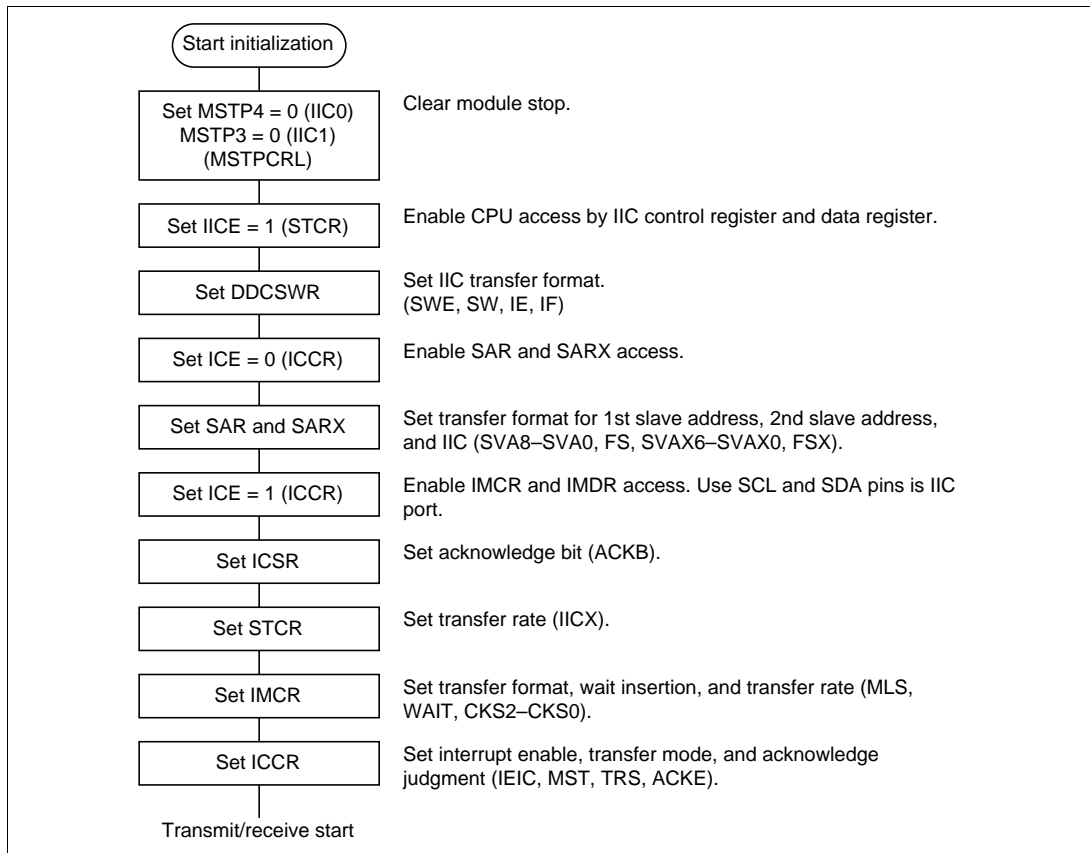
**Table 18-4 I<sup>2</sup>C Bus Data Format Symbols**

**Legend**

S	Start condition. The master device drives SDA from high to low while SCL is high
SLA	Slave address, by which the master device selects a slave device
$\overline{R/W}$	Indicates the direction of data transfer: from the slave device to the master device when $\overline{R/W}$ is 1, or from the master device to the slave device when $\overline{R/W}$ is 0
A	Acknowledge. The receiving device (the slave in master transmit mode, or the master in master receive mode) drives SDA low to acknowledge a transfer
DATA	Transferred data. The bit length is set by bits BC2 to BC0 in ICMR. The MSB-first or LSB-first format is selected by bit MLS in ICMR
P	Stop condition. The master device drives SDA from low to high while SCL is high

### 18.3.2 Initial Setting

At startup the following procedure is used to initialize the IIC.



**Figure 18-6 Flowchart for IIC Initialization (Example)**

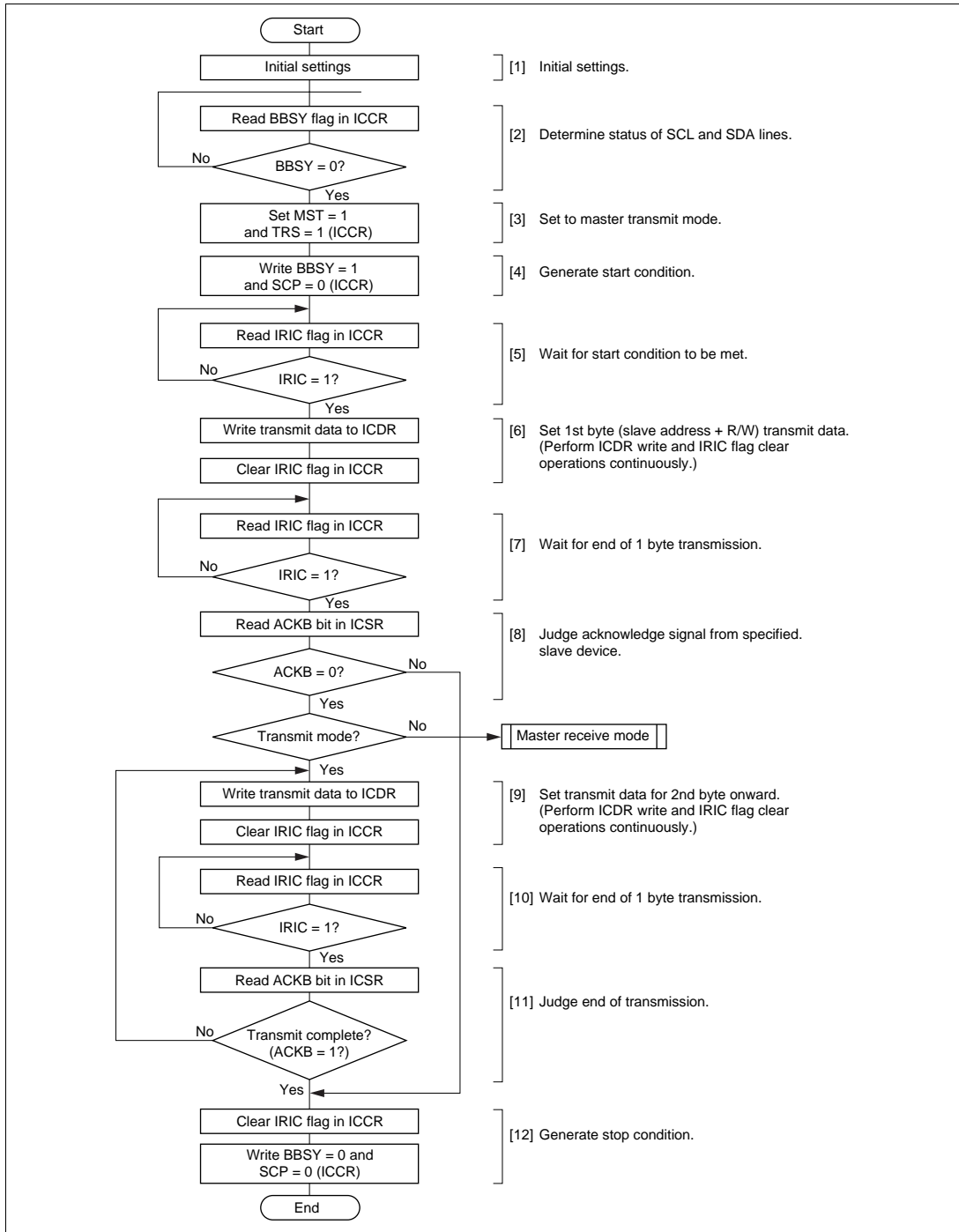
Note: The ICMR register should be written to only after transmit or receive operations have completed.

Writing to the ICMR register while a transmit or receive operation is in progress could cause an erroneous value to be written to bit counter bits BC2 to BC0. This could result in improper operation.

### 18.3.3 Master Transmit Operation

In I<sup>2</sup>C bus format master transmit mode, the master device outputs the transmit clock and transmit data, and the slave device returns an acknowledge signal.

Figure 18-7 is a flowchart showing an example of the master transmit mode.

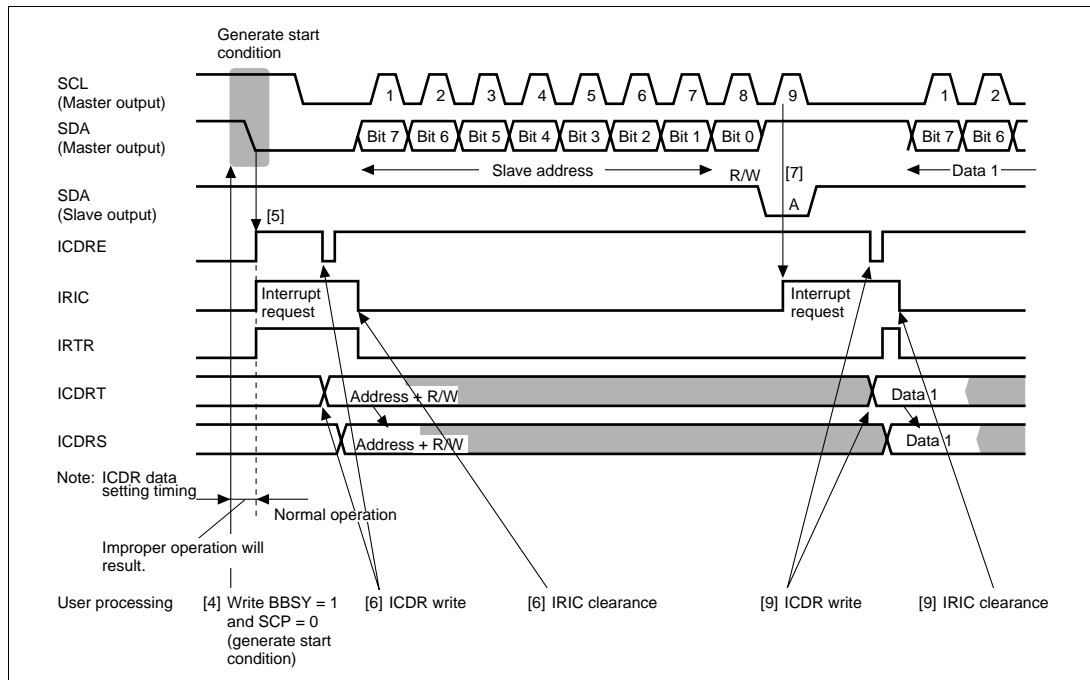


**Figure 18-7 Flowchart for Master Transmit Mode (Example)**

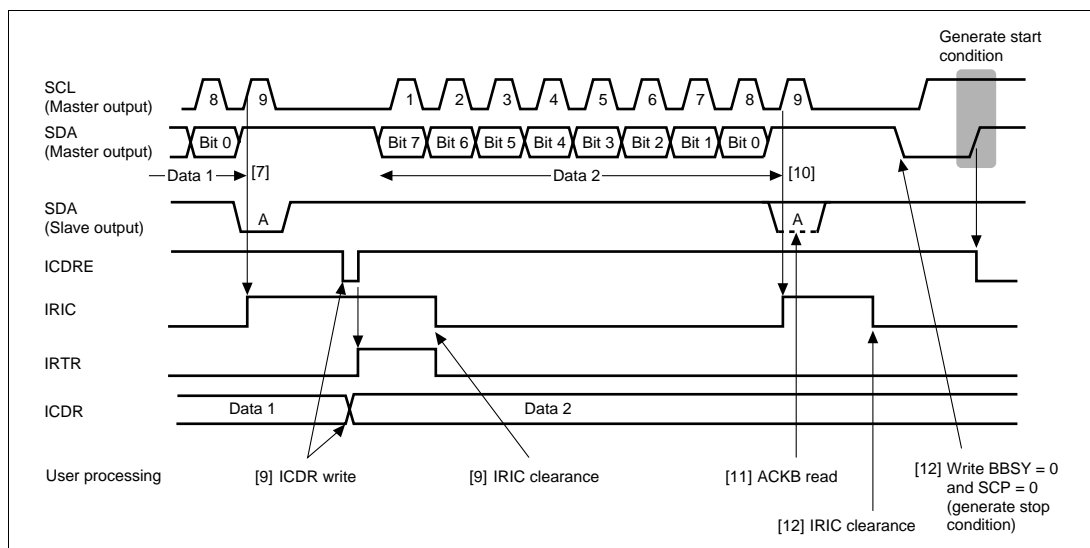
The procedure for transmitting data sequentially, synchronized with ICDR (ICDRT) write operations, is described below.

- [1] Perform initial settings as described in section 18.3.2, Initial Setting.
- [2] Read the BBSY flag in ICCR to confirm that the bus is free.
- [3] Set bits MST and TSR in ICCR to 1 to switch to the master transmit mode.
- [4] Write 1 to BBSY and 0 to SCP in ICCR. This changes SDA from high to low when SCL is high, and generates the start condition.
- [5] The IRIC and IRTR flags are set to 1 when the start condition is generated. If the IEIC bit in ICCR has been set to 1, an interrupt request is sent to the CPU.
- [6] After the start condition is detected, write the data (slave address + R/W) to ICDR. With the I<sup>2</sup>C bus format (when the FS bit in SAR or the FSX bit in SARX is 0), the first frame data following the start condition indicates the 7-bit slave address and transmit/receive direction (R/W). Next, clear the IRIC flag to 0 to indicate the end of the transfer. Continue successively writing to ICDR and clearing the IRIC flag to ensure that processing of other interrupts does not intervene. If the time required to transmit one byte of data elapses by the time the IRIC flag is cleared, it will not be possible to determine the end of the transmission. The master device sequentially sends the transmit clock and the data written to ICDR. The selected slave device (i.e., the slave device with the matching slave address) drives SDA low at the 9th transmit clock pulse and returns an acknowledge signal.
- [7] When one frame of data has been transmitted, the IRIC flag is set to 1 at the rise of the 9th transmit clock pulse. After one frame has been transmitted, SCL is automatically fixed low in synchronization with the internal clock until the next transmit data is written.
- [8] Read the ACKB bit in ICSR to confirm that its value is 0. If the slave device has not returned an acknowledge signal and the value of ACKB is 1, perform the transmit end processing described in step [12] and then recommence the transmit operation from the beginning.
- [9] Write the transmit data to ICDR. Next, clear the IRIC flag to 0 to indicate the end of the transfer. Then continue successively writing to ICDR and clearing the IRIC flag as described in step [6]. Transmission of the next frame is synchronized with the internal clock.
- [10] When one frame of data has been transmitted, the IRIC flag is set to 1 at the rise of the 9th transmit clock pulse. After one frame has been transmitted, SCL is automatically fixed low in synchronization with the internal clock until the next transmit data is written.
- [11] Read the ACKB bit in ICSR to confirm that the slave device has returned an acknowledge signal and the value of ACKB is 0. If the slave device has not returned an acknowledge signal and the value of ACKB is 1, perform the transmit end processing described in step [12].
- [12] Clear the IRIC flag to 0. Write 0 to the ACKE bit in ICCR and clear the received ACKB bit to 0.

Write 0 to BBSY and SCP in ICCR. This changes SDA from low to high when SCL is high, and generates the stop condition.



**Figure 18-8 Example of Master Transmit Mode Operation Timing (MLS = WAIT = 0)**



**Figure 18-9 Example of Master Transmit Mode Stop Condition Generation Timing (MLS = WAIT = 0)**

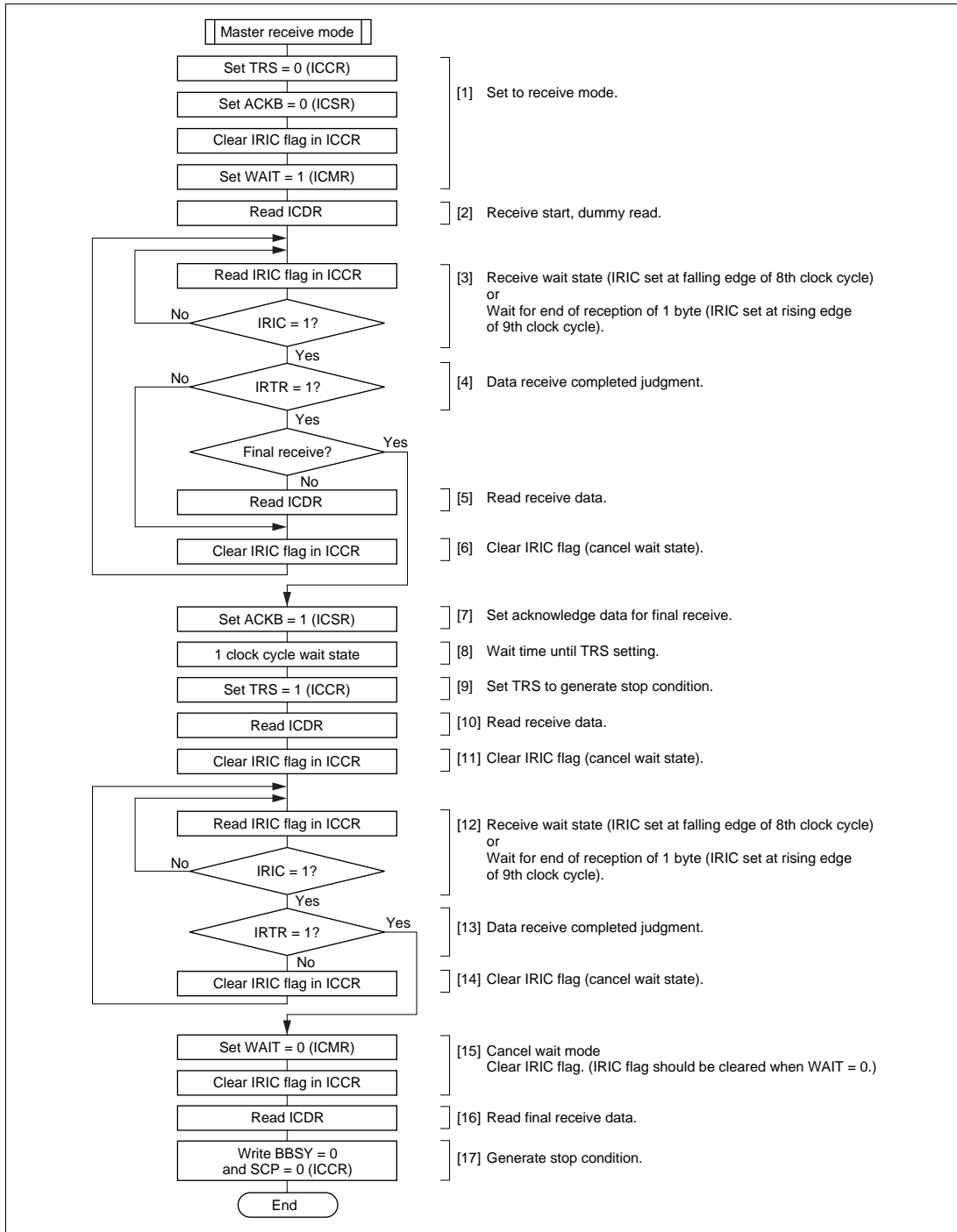
### **18.3.4 Master Receive Operation**

In I<sup>2</sup>C bus format master receive mode, the master device outputs the receive clock, receives data, and returns an acknowledge signal. The slave device transmits data.

The master device transmits the data containing the slave address + R/W (0: read) in the 1st frame after a start condition is generated in the master transmit mode. After the slave device is selected the switch to receive operation takes place.

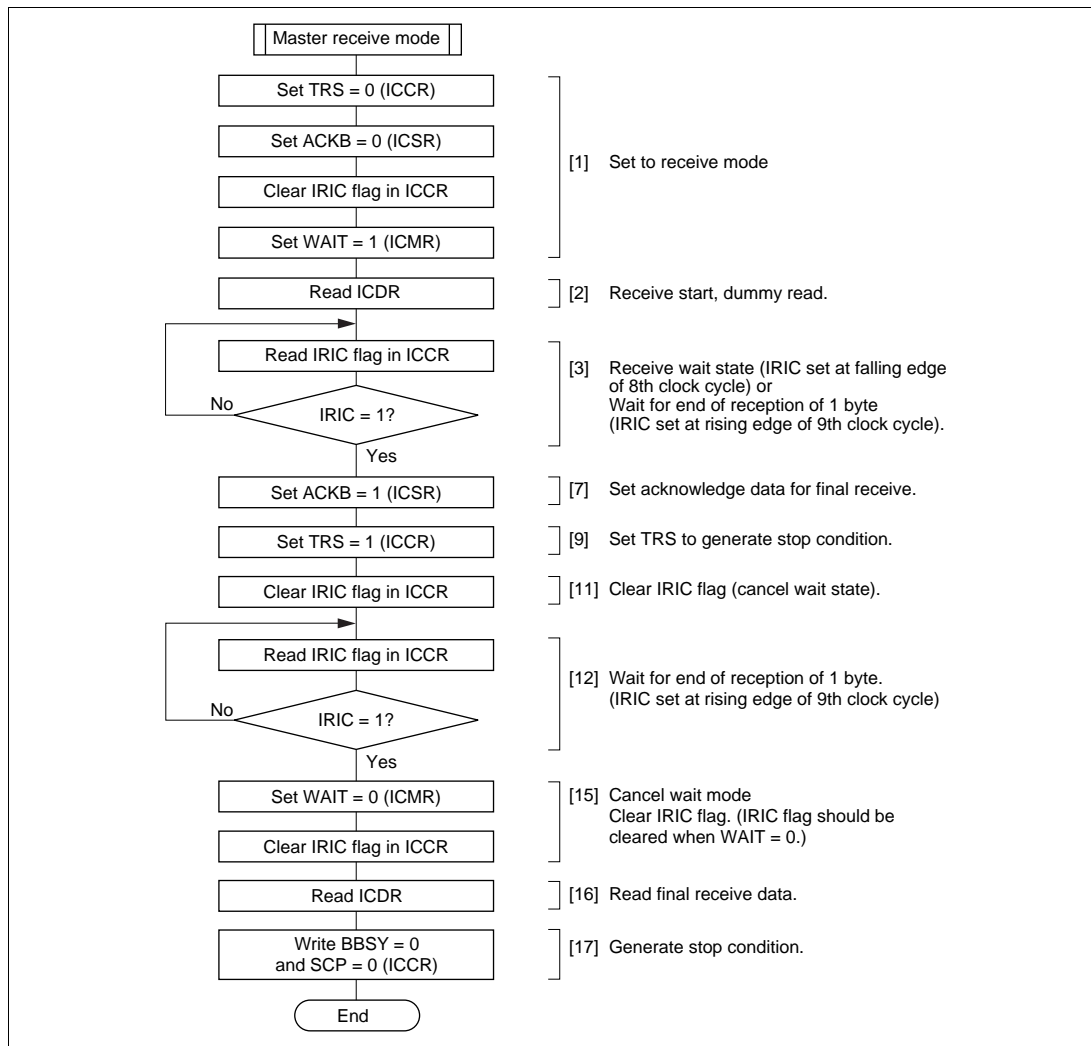
#### **(1) Receive Operation Using Wait States**

Figures 18-10 and 18-11 are flowcharts showing examples of the master receive mode (WAIT = 1).



**Figure 18-10 Flowchart for Master Receive Mode (Receiving Multiple Bytes) (WAIT = 1) (Example)**





**Figure 18-11 Flowchart for Master Receive Mode (Receiving 1 Byte) (WAIT = 1) (Example)**

The procedure for receiving data sequentially, using the wait states (WAIT bit) for synchronization with ICDR (ICDRR) read operations, is described below.

The procedure below describes the operation for receiving multiple bytes. Note that some of the steps are omitted when receiving only 1 byte. Refer to figure 18-11 for details.

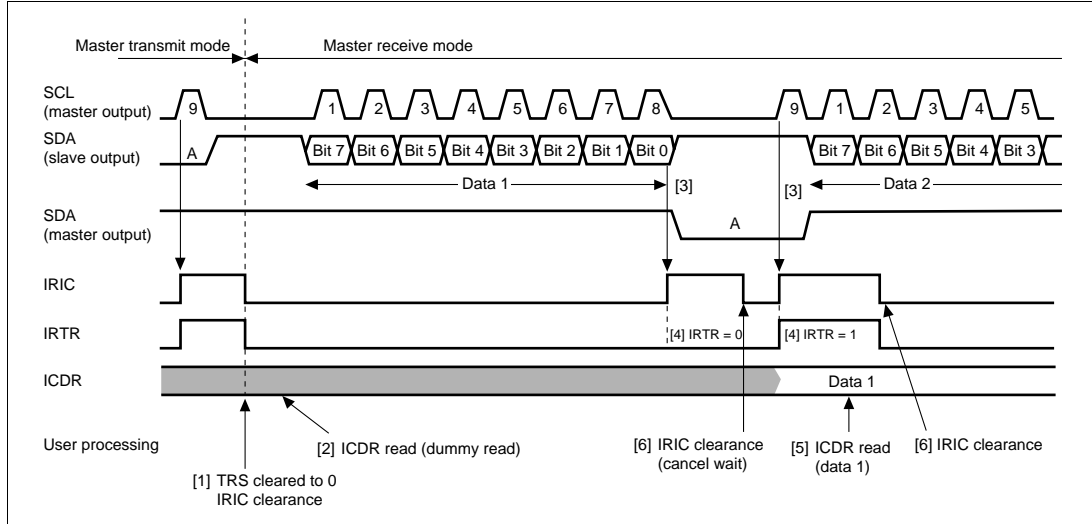
- [1] Clear the TRS bit in ICCR to 0 to switch from transmit mode to receive mode. Clear the ACKB bit in ICSR to 0 (acknowledge data setting). Clear the HNDS bit in ICXR to 0 (cancel handshake function). Clear the IRIC flag to 0, then set the WAIT bit in ICMR to 1.

- [2] When ICDR is read (dummy data read), reception is started, and the receive clock is output, and data received, in synchronization with the internal clock.
- [3] The IRIC flag is set to 1 by the following two conditions. At that point, an interrupt request is issued to the CPU if the IEIC bit in ICCR is set to 1.
  - 1. The flag is set at the falling edge of the 8th clock cycle of the receive clock for 1 frame. SCL is automatically held low, in synchronization with the internal clock, until the IRIC flag is cleared.
  - 2. The flag is set at the rising edge of the 9th clock cycle of the receive clock for 1 frame. The IRIC flag and ICDRF flag are set to 1, indicating that reception of 1 frame of data has ended. The master device continues to output the receive clock for the receive data.
- [4] Read the IRTR flag in ICSR. If the IRTR flag value is 0, the wait state is cancelled by clearing the IRIC flag as described in step [6] below. If the IRTR flag value is 1 and the next receive data is the final receive data, perform the end processing described in step [7] below.
- [5] If the IRTR flag value is 1, read the ICDR receive data.
- [6] Clear the IRTR flag to 0. If condition [3]-1 is true, the master device drives SDA to low level and returns an acknowledge signal when the receive clock outputs the 9th clock cycle. Further data can be received by repeating steps [3] through [6].
- [7] Set the ACKB bit in ICSR to 1 to set the acknowledge data for the final receive.
- [8] Wait for at least 1 clock cycle after the IRIC flag is set to 1 and then wait for the rising edge of the 1st clock cycle of the next receive data.
- [9] Set the TSR bit in ICCR to 1 to switch from the receive mode to the transmit mode. The TSR bit setting value at this point becomes valid when the rising edge of the next 9th clock cycle is input.
- [10] Read the ICDR receive data.
- [11] Clear the IRTR flag to 0.
- [12] The IRIC flag is set to 1 by the following two conditions.
  - 1. The flag is set at the falling edge of the 8th clock cycle of the receive clock for 1 frame. SCL is automatically held low, in synchronization with the internal clock, until the IRIC flag is cleared.
  - 2. The flag is set at the rising edge of the 9th clock cycle of the receive clock for 1 frame. The IRIC flag and ICDRF flag are set to 1, indicating that reception of 1 frame of data has ended. The master device continues to output the receive clock for the receive data.
- [13] Read the IRTR flag in ICSR. If the IRTR flag value is 0, the wait state is cancelled by clearing the IRIC flag as described in step [14] below. If the IRTR flag value is 1 and the receive operation has finished, perform the issue stop condition processing described in step [15] below.
- [14] If the IRTR flag value is 0, clear the IRIC flag to 0 to cancel the wait state. Return to reading the IRIC flag, as described in step [12], to detect the end of the receive operation.
- [15] Clear the WAIT bit in ICMR to 0 to cancel the wait mode. Then clear the IRIC flag to 0. The IRIC flag should be cleared when the value of WAIT is 0. (The stop condition may not be

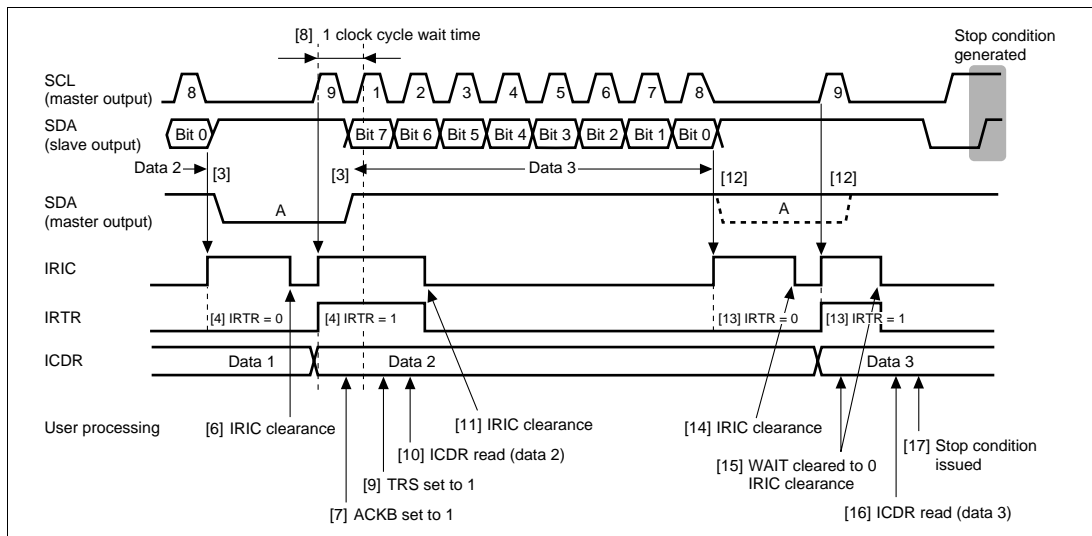
output properly when the issue stop condition instruction is executed if the WAIT bit was cleared to 0 after the IRIC flag is cleared to 0.)

[16] Read the final receive data in ICDR.

[17] Write 0 to BBSY and SCP in ICCR. This changes SDA from low to high when SCL is high, and generates the stop condition.



**Figure 18-12 Example of Master Receive Mode Operation Timing**  
(MLS = ACKB = 0, WAIT = 1)



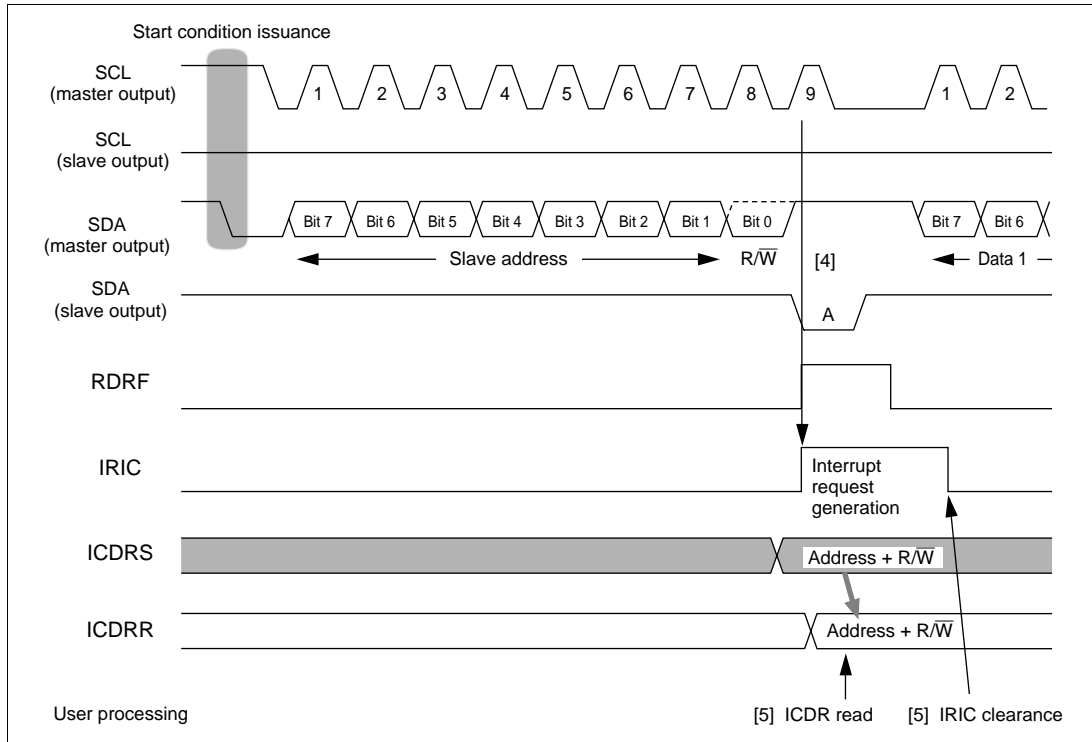
**Figure 18-13 Example of Master Receive Mode Stop Condition Generation Timing**  
(MLS = ACKB = 0, WAIT = 1)

### 18.3.5 Slave Receive Operation

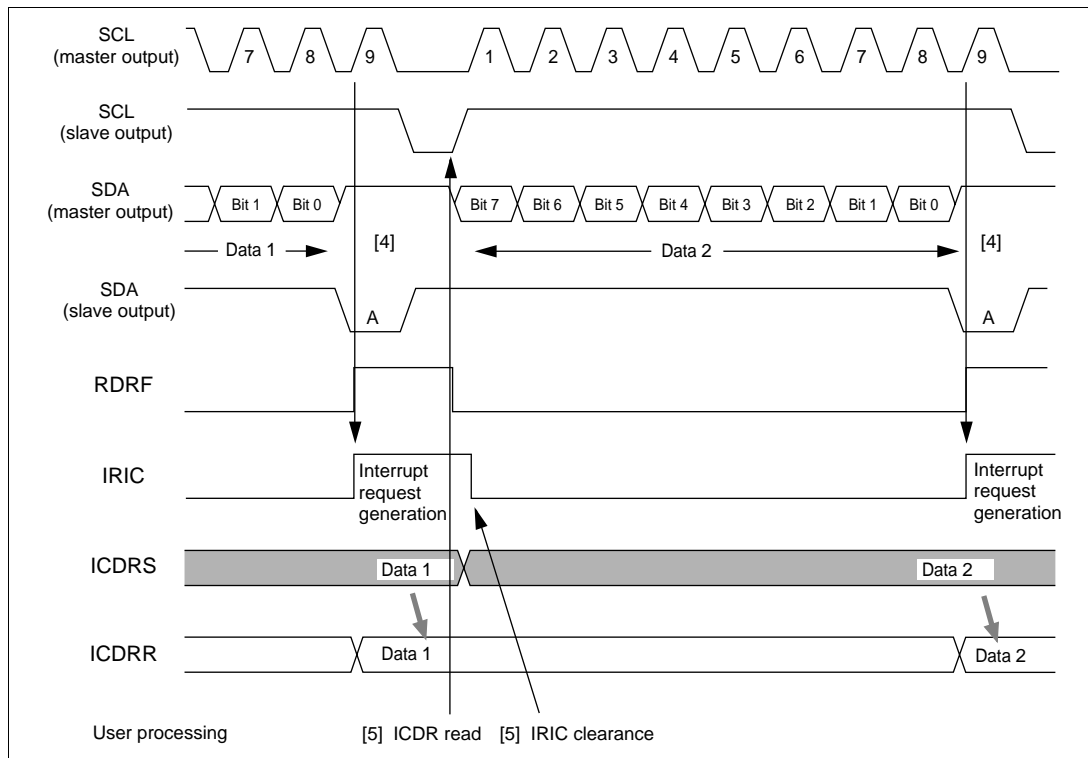
In slave receive mode, the master device outputs the transmit clock and transmit data, and the slave device returns an acknowledge signal. The reception procedure and operations in slave receive mode are described below.

- (1) Set the ICE bit in ICCR to 1. Set the MLS bit in ICMR and the MST and TRS bits in ICCR according to the operating mode.
- (2) When the start condition output by the master device is detected, the BBSY flag in ICCR is set to 1.
- (3) When the slave address matches in the first frame following the start condition, the device operates as the slave device specified by the master device. If the 8th data bit ( $R/\overline{W}$ ) is 0, the TRS bit in ICCR remains cleared to 0, and slave receive operation is performed.
- (4) At the 9th clock pulse of the receive frame, the slave device drives SDA low and returns an acknowledge signal. At the same time, the IRIC flag in ICCR is set to 1. If the IEIC bit in ICCR has been set to 1, an interrupt request is sent to the CPU. If the RDRF internal flag has been cleared to 0, it is set to 1, and the receive operation continues. If the RDRF internal flag has been set to 1, the slave device drives SCL low from the fall of the receive clock until data is read into ICDR.
- (5) Read ICDR and clear the IRIC flag in ICCR to 0. The RDRF flag is cleared to 0.

Receive operations can be performed continuously by repeating steps (4) and (5). When SDA is changed from low to high when SCL is high, and the stop condition is detected, the BBSY flag in ICCR is cleared to 0.



**Figure 18-14 Example of Slave Receive Mode Operation Timing (1)**  
**(MLS = ACKB = 0)**



**Figure 18-15 Example of Slave Receive Mode Operation Timing (2)**  
( $MLS = ACKB = 0$ )

### 18.3.6 Slave Transmit Operation

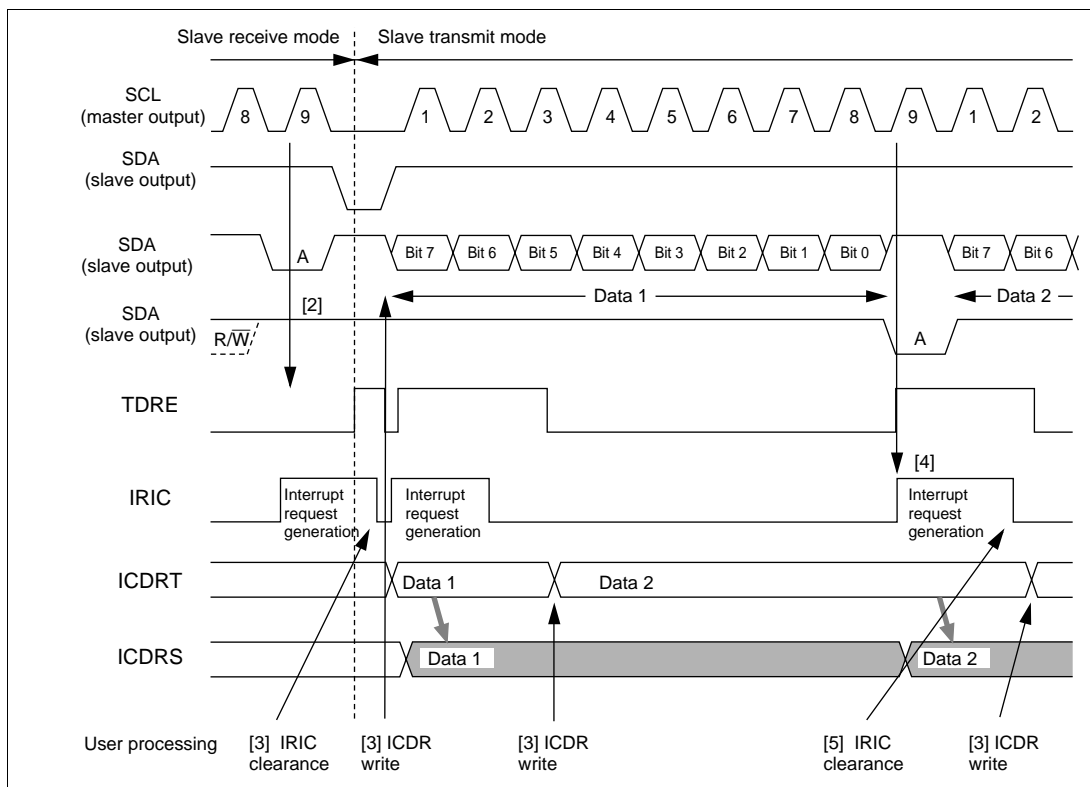
In slave transmit mode, the slave device outputs the transmit data, while the master device outputs the receive clock and returns an acknowledge signal. The transmission procedure and operations in slave transmit mode are described below.

- (1) Set the ICE bit in ICCR to 1. Set the MLS bit in ICMR and the MST and TRS bits in ICCR according to the operating mode.
- (2) When the slave address matches in the first frame following detection of the start condition, the slave device drives SDA low at the 9th clock pulse and returns an acknowledge signal. At the same time, the IRIC flag in ICCR is set to 1. If the IEIC bit in ICCR has been set to 1, an interrupt request is sent to the CPU. If the 8th data bit ( $R/\bar{W}$ ) is 1, the TRS bit in ICCR is set to 1, and the mode changes to slave transmit mode automatically. The TDRF flag is set to 1. The slave device drives SCL low from the fall of the transmit clock until ICDR data is written.
- (3) After clearing the IRIC flag to 0, write data to ICDR. The TDRE internal flag is cleared to 0. The written data is transferred to ICDRS, and the TDRE internal flag and the IRIC and IRTR flags are set to 1 again. After clearing the IRIC flag to 0, write the next data to ICDR. The

slave device sequentially sends the data written into ICDR in accordance with the clock output by the master device at the timing shown in figure 18-16.

- (4) When one frame of data has been transmitted, the IRIC flag in ICCR is set to 1 at the rise of the 9th transmit clock pulse. If the TDRE internal flag has been set to 1, this slave device drives SCL low from the fall of the transmit clock until data is written to ICDR. The master device drives SDA low at the 9th clock pulse, and returns an acknowledge signal. As this acknowledge signal is stored in the ACKB bit in ICSR, this bit can be used to determine whether the transfer operation was performed normally. When the TDRE internal flag is 0, the data written into ICDR is transferred to ICDRS, transmission is started, and the TDRE internal flag and the IRIC and IRTR flags are set to 1 again.
- (5) To continue transmission, clear the IRIC flag to 0, then write the next data to be transmitted into ICDR. The TDRE flag is cleared to 0.

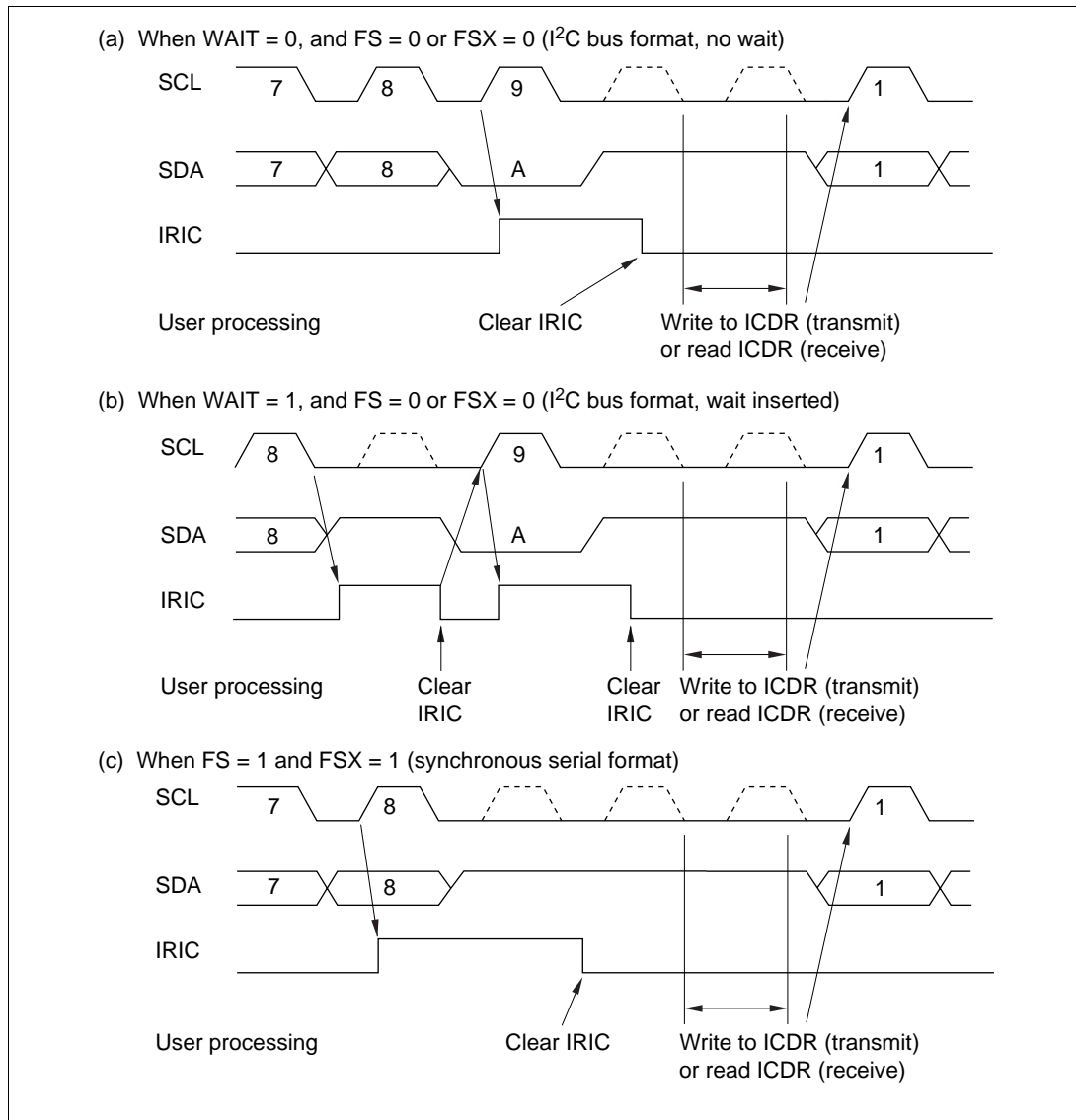
Transmit operations can be performed continuously by repeating steps (4) and (5). To end transmission, write H'FF to ICDR to release SDA on the slave side. When SDA is changed from low to high when SCL is high, and the stop condition is detected, the BBSY flag in ICCR is cleared to 0.



**Figure 18-16 Example of Slave Transmit Mode Operation Timing**  
(MLS = 0)

### 18.3.7 IRIC Setting Timing and SCL Control

The interrupt request flag (IRIC) is set at different times depending on the WAIT bit in ICMR, the FS bit in SAR, and the FSX bit in SARX. If the TDRE or RDRF internal flag is set to 1, SCL is automatically held low after one frame has been transferred; this timing is synchronized with the internal clock. Figure 18-17 shows the IRIC set timing and SCL control.



**Figure 18-17 IRIC Setting Timing and SCL Control**



### 18.3.8 Operation Using the DTC\*

The I<sup>2</sup>C bus format provides for selection of the slave device and transfer direction by means of the slave address and the R/W bit, confirmation of reception with the acknowledge bit, indication of the last frame, and so on. Therefore, continuous data transfer using the DTC\* must be carried out in conjunction with CPU processing by means of interrupts.

Table 18-5 shows some examples of processing using the DTC\*. These examples assume that the number of transfer data bytes is known in slave mode.

Note: \* The DTC function is not available in the H8S/2695.

**Table 18-5 Examples of Operation Using the DTC\***

Item	Master Transmit Mode	Master Receive Mode	Slave Transmit Mode	Slave Receive Mode
Slave address + R/W bit transmission/reception	Transmission by DTC* (ICDR write)	Transmission by CPU (ICDR write)	Reception by CPU (ICDR read)	Reception by CPU (ICDR read)
Dummy data read	—	Processing by CPU (ICDR read)	—	—
Actual data transmission/reception	Transmission by DTC* (ICDR write)	Reception by DTC* (ICDR read)	Transmission by DTC* (ICDR write)	Reception by DTC* (ICDR read)
Dummy data (H'FF) write	—	—	Processing by DTC* (ICDR write)	—
Last frame processing	Not necessary	Reception by CPU (ICDR read)	Not necessary	Reception by CPU (ICDR read)
Transfer request processing after last frame processing	1st time: Clearing by CPU 2nd time: End condition issuance by CPU	Not necessary	Automatic clearing on detection of end condition during transmission of dummy data (H'FF)	Not necessary
Setting of number of DTC* transfer data frames	Transmission: Actual data count + 1 (+1 equivalent to slave address + R/W bits)	Reception: Actual data count	Transmission: Actual data count + 1 (+1 equivalent to dummy data (H'FF))	Reception: Actual data count

Note: \* The DTC function is not available in the H8S/2695.

### 18.3.9 Noise Canceler

The logic levels at the SCL and SDA pins are routed through noise cancelers before being latched internally. Figure 18-18 shows a block diagram of the noise canceler circuit.

The noise canceler consists of two cascaded latches and a match detector. The SCL (or SDA) input signal is sampled on the system clock, but is not passed forward to the next circuit unless the outputs of both latches agree. If they do not agree, the previous value is held.

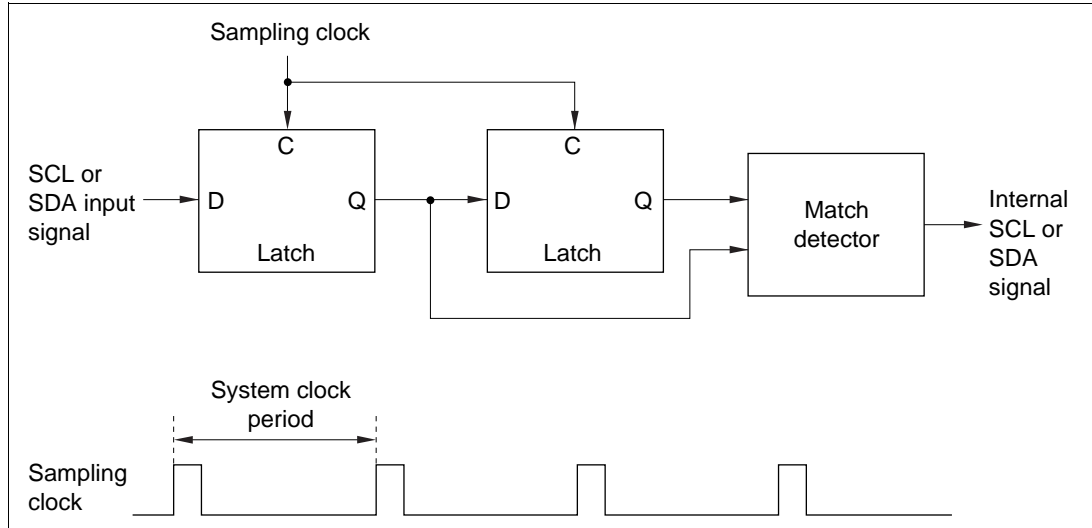
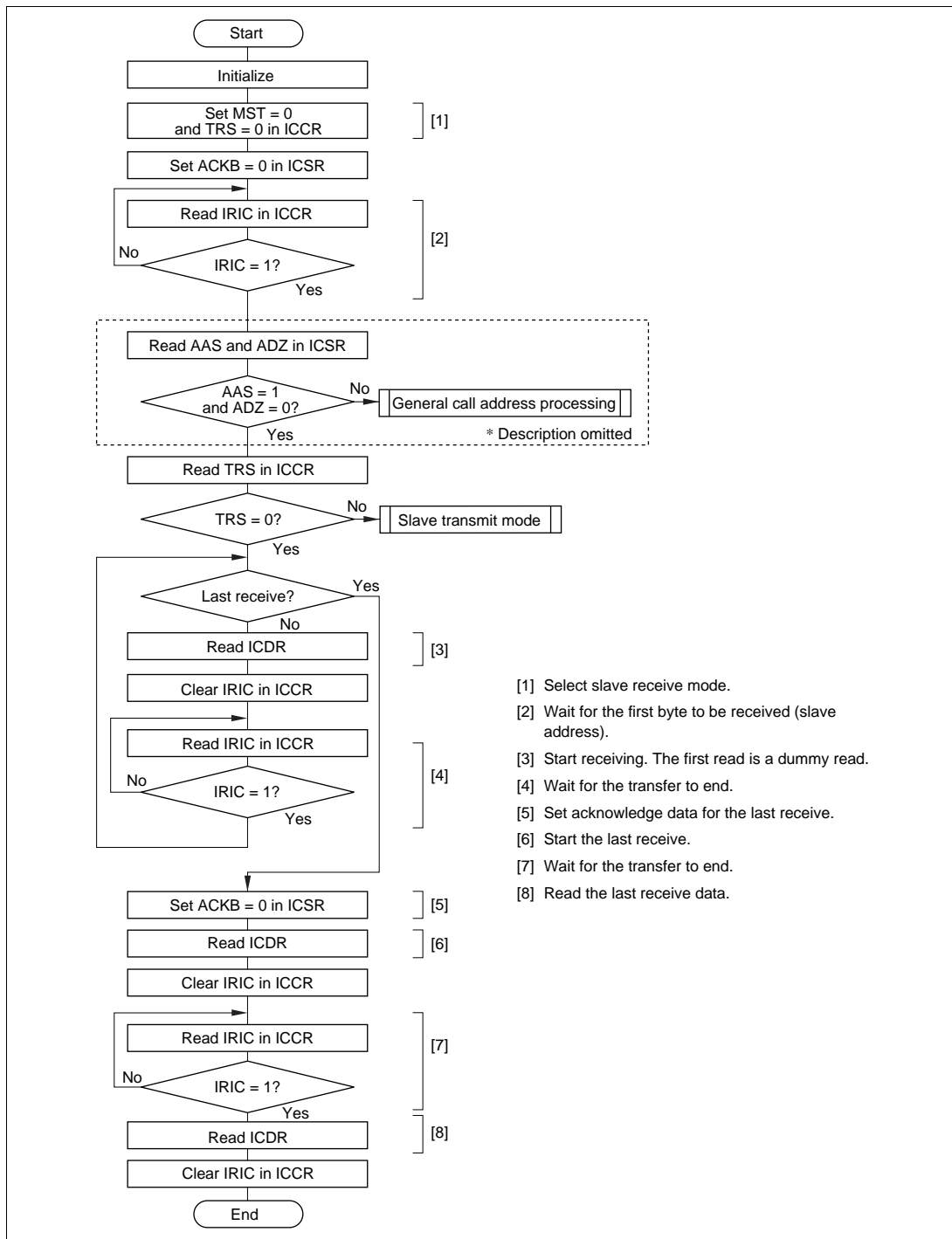


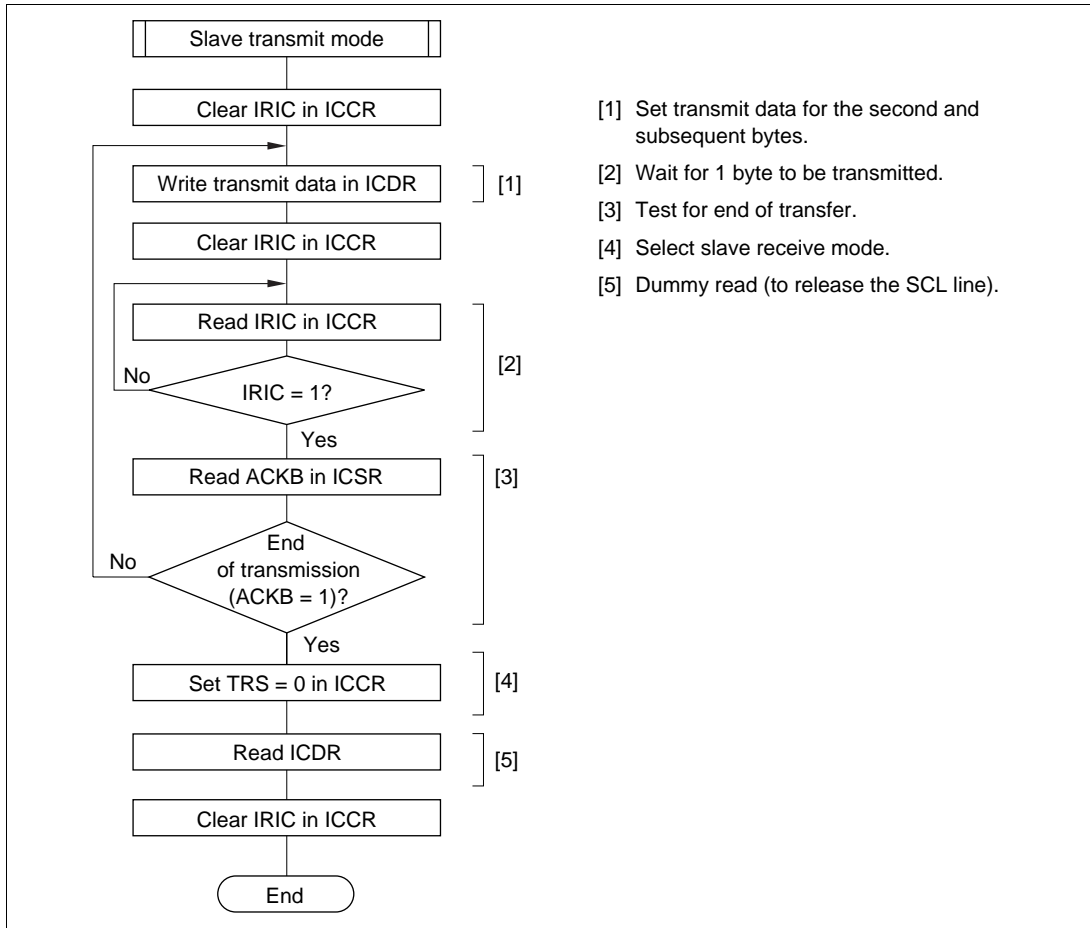
Figure 18-18 Block Diagram of Noise Canceler

### 18.3.10 Sample Flowcharts

Figures 18-19 and 18-20 show sample flowcharts for using the I<sup>2</sup>C bus interface in each mode.



**Figure 18-19 Flowchart for Slave Transmit Mode (Example)**



**Figure 18-20 Flowchart for Slave Receive Mode (Example)**

### 18.3.11 Initialization of Internal State

The IIC has a function for forcible initialization of its internal state if a deadlock occurs during communication.

Initialization is executed by (1) setting bits CLR3 to CLR0 in the DDCCSWR register or (2) clearing the ICE bit. For details of settings for bits CLR3 to CLR0, see section 18.2.8, DDC Switch Register (DDCCSWR).

**Scope of Initialization:** The initialization executed by this function covers the following items:

- TDRE and RDRF internal flags
- Transmit/receive sequencer and internal operating clock counter
- Internal latches for retaining the output state of the SCL and SDA pins (wait, clock, data output, etc.)

The following items are not initialized:

- Actual register values (ICDR, SAR, SARX, ICMR, ICCR, ICSR, DDCCSWR, and STCR)
- Internal latches used to retain register read information for setting/clearing flags in the ICMR, ICCR, ICSR, and DDCCSWR registers
- The value of the ICMR register bit counter (BC2 to BC0)
- Generated interrupt sources (interrupt sources transferred to the interrupt controller)

#### **Notes on Initialization:**

- Interrupt flags and interrupt sources are not cleared, and so flag clearing measures must be taken as necessary.
- Basically, other register flags are not cleared either, and so flag clearing measures must be taken as necessary.
- When initialization is performed by means of the DDCCSWR register, the write data for bits CLR3 to CLR0 is not retained. To perform IIC clearance, bits CLR3 to CLR0 must be written to simultaneously using an MOV instruction. Do not use a bit manipulation instruction such as BCLR. Similarly, when clearing is required again, all the bits must be written to simultaneously in accordance with the setting.
- If a flag clearing setting is made during transmission/reception, the IIC module will stop transmitting/receiving at that point and the SCL and SDA pins will be released. When transmission/reception is started again, register initialization, etc., must be carried out as necessary to enable correct communication as a system.

The value of the BBSY bit cannot be modified directly by this module clear function, but since the stop condition pin waveform is generated according to the state and release timing of the SCL and SDA pins, the BBSY bit may be cleared as a result. Similarly, state switching of other bits and flags may also have an effect.

To prevent problems caused by these factors, the following procedure should be used when initializing the IIC state.

1. Execute initialization of the internal state according to the setting of bits CLR3 to CLR0, or according to the ICE bit.
2. Execute a stop condition issuance instruction (write 0 to BBSY and SCP) to clear the BBST bit to 0, and wait for two transfer rate clock cycles.
3. Re-execute initialization of the internal state according to the setting of bits CLR3 to CLR0, or according to the ICE bit.
4. Initialize (re-set) the IIC registers.

## 18.4 Usage Notes

- In master mode, if an instruction to generate a start condition is immediately followed by an instruction to generate a stop condition, neither condition will be output correctly. To output consecutive start and stop conditions, after issuing the instruction that generates the start condition, read the relevant ports, check that SCL and SDA are both low, then issue the instruction that generates the stop condition. Note that SCL may not yet have gone low when BBSY is cleared to 0.
- Either of the following two conditions will start the next transfer. Pay attention to these conditions when reading or writing to ICDR.
  - Write access to ICDR when ICE = 1 and TRS = 1 (including automatic transfer from ICDRT to ICDRS)
  - Read access to ICDR when ICE = 1 and TRS = 0 (including automatic transfer from ICDRS to ICDRR)
- Table 18-6 shows the timing of SCL and SDA output in synchronization with the internal clock. Timings on the bus are determined by the rise and fall times of signals affected by the bus load capacitance, series resistance, and parallel resistance.

**Table 18-6 I<sup>2</sup>C Bus Timing (SCL and SDA Output)**

Item	Symbol	Output Timing	Unit	Notes
SCL output cycle time	$t_{SCLC}$	$28t_{cyc}$ to $256t_{cyc}$	ns	Figure 25-33,
SCL output high pulse width	$t_{SCLH}$	$0.5t_{SCLC}$	ns	figure 26-33
SCL output low pulse width	$t_{SCLL}$	$0.5t_{SCLC}$	ns	(reference)
SDA output bus free time	$t_{BUFO}$	$0.5t_{SCLC} - 1t_{cyc}$	ns	
Start condition output hold time	$t_{STAHO}$	$0.5t_{SCLC} - 1t_{cyc}$	ns	
Retransmission start condition output setup time	$t_{STASO}$	$1t_{SCLC}$	ns	
Stop condition output setup time	$t_{STOSO}$	$0.5t_{SCLC} + 2t_{cyc}$	ns	
Data output setup time (master)	$t_{SDASO}$	$1t_{SCLL} - 3t_{cyc}$	ns	
Data output setup time (slave)		$1t_{SCLL} - 3t_{cyc}$		
Data output hold time	$t_{SDAHO}$	$3t_{cyc}$	ns	

Note: \* $6t_{cyc}$  when IICX is 0,  $12t_{cyc}$  when 1.

- SCL and SDA input is sampled in synchronization with the internal clock. The AC timing therefore depends on the system clock cycle  $t_{cyc}$ , as shown in tables 25-10 and 26-10 in section 25 and 26, Electrical Characteristics. Note that the I<sup>2</sup>C bus interface AC timing specifications will not be met with a system clock frequency of less than 5 MHz.
- The I<sup>2</sup>C bus interface specification for the SCL rise time  $t_{sr}$  is under 1000 ns (300 ns for high-speed mode). In master mode, the I<sup>2</sup>C bus interface monitors the SCL line and synchronizes one bit at a time during communication. If  $t_{sr}$  (the time for SCL to go from low to  $V_{IH}$ ) exceeds the time determined by the input clock of the I<sup>2</sup>C bus interface, the high period of SCL is extended. The SCL rise time is determined by the pull-up resistance and load capacitance of the SCL line. To insure proper operation at the set transfer rate, adjust the pull-up resistance and load capacitance so that the SCL rise time does not exceed the values given in the table 18-7.

**Table 18-7 Permissible SCL Rise Time ( $t_{sr}$ ) Values**

		Time Indication								
IICX	$t_{cyc}$ Indication		I <sup>2</sup> C Bus Specification (Max.)	$\phi =$	$\phi =$	$\phi =$	$\phi =$	$\phi =$	$\phi =$	$\phi =$
				5 MHz	8 MHz	10 MHz	16 MHz	20 MHz	25 MHz	28 MHz
0	7.5 $t_{cyc}$	Standard mode	1000 ns	1000 ns	937 ns	750 ns	468 ns	375 ns	300 ns	267 ns
		High-speed mode	300 ns	300 ns	300 ns	300 ns	300 ns	300 ns	300 ns	300 ns
1	17.5 $t_{cyc}$	Standard mode	1000 ns	1000 ns	1000 ns	1000 ns	1000 ns	875 ns	700 ns	624 ns
		High-speed mode	300 ns	300 ns	300 ns	300 ns	300 ns	300 ns	300 ns	300 ns

- The I<sup>2</sup>C bus interface specifications for the SCL and SDA rise and fall times are under 1000 ns and 300 ns. The I<sup>2</sup>C bus interface SCL and SDA output timing is prescribed by  $t_{scyc}$  and  $t_{cyc}$ , as shown in table 18-6. However, because of the rise and fall times, the I<sup>2</sup>C bus interface specifications may not be satisfied at the maximum transfer rate. Table 18-8 shows output timing calculations for different operating frequencies, including the worst-case influence of rise and fall times.

$t_{BUFO}$  fails to meet the I<sup>2</sup>C bus interface specifications at any frequency. The solution is either (a) to provide coding to secure the necessary interval (approximately 1  $\mu$ s) between issuance of a stop condition and issuance of a start condition, or (b) to select devices whose input timing permits this output timing for use as slave devices connected to the I<sup>2</sup>C bus.

$t_{SCLLO}$  in high-speed mode and  $t_{STASO}$  in standard mode fail to satisfy the I<sup>2</sup>C bus interface specifications for worst-case calculations of  $t_{sr}/t_{sf}$ . Possible solutions that should be investigated include (a) adjusting the rise and fall times by means of a pull-up resistor and capacitive load, (b) reducing the transfer rate to meet the specifications, or (c) selecting devices whose input timing permits this output timing for use as slave devices connected to the I<sup>2</sup>C bus.



**Table 18-8 I<sup>2</sup>C Bus Timing (with Maximum Influence of  $t_{sr}/t_{sf}$ )**

Item	$t_{cyc}$ Indication		Time Indication (at Maximum Transfer Rate) [ns]								
			$t_{sr}/t_{sf}$ Influence (Max.)	I <sup>2</sup> C Bus Specifi- cation (Min.)	$\phi =$	$\phi =$	$\phi =$	$\phi =$	$\phi =$	$\phi =$	$\phi =$
					5 MHz	8 MHz	10 MHz	16 MHz	20 MHz	25 MHz	28 MHz
$t_{SCLHO}$	$0.5t_{SCLO}$ ( $-t_{sr}$ )	Standard mode	-1000	4000	4000	4000	4000	4000	4000	4000	4000
		High-speed mode	-300	600	950	950	950	950	950	950	950
$t_{SCLLO}$	$0.5t_{SCLO}$ ( $-t_{sf}$ )	Standard mode	-250	4700	4750	4750	4750	4750	4750	4750	4750
		High-speed mode	-250	1300	1000* <sup>1</sup>	1000* <sup>1</sup>	1000* <sup>1</sup>	1000* <sup>1</sup>	1000* <sup>1</sup>	1000* <sup>1</sup>	1000* <sup>1</sup>
$t_{BUFO}$	$0.5t_{SCLO} - 1t_{cyc}$ ( $-t_{sr}$ )	Standard mode	-1000	4700	3800* <sup>1</sup>	3875* <sup>1</sup>	3900* <sup>1</sup>	3938* <sup>1</sup>	3950* <sup>1</sup>	3960* <sup>1</sup>	3964* <sup>1</sup>
		High-speed mode	-300	1300	750* <sup>1</sup>	825* <sup>1</sup>	850* <sup>1</sup>	888* <sup>1</sup>	900* <sup>1</sup>	910* <sup>1</sup>	912* <sup>1</sup>
$t_{STAHO}$	$0.5t_{SCLO} - 1t_{cyc}$ ( $-t_{sf}$ )	Standard mode	-250	4000	4550	4625	4650	4688	4700	4710	4713
		High-speed mode	-250	600	800	875	900	938	950	960	964
$t_{STASO}$	$1t_{SCLO}$ ( $-t_{sr}$ )	Standard mode	-1000	4700	9000	9000	9000	9000	9000	9000	9000
		High-speed mode	-300	600	2200	2200	2200	2200	2200	2200	2200
$t_{STOSO}$	$0.5t_{SCLO} + 2t_{cyc}$ ( $-t_{sr}$ )	Standard mode	-1000	4000	4400	4250	4200	4125	4100	4080	4071
		High-speed mode	-300	600	1350	1200	1150	1075	1050	1030	1021
$t_{SDASO}$ (master)	$1t_{SCLLO}^{*2} - 3t_{cyc}$ ( $-t_{sr}$ )	Standard mode	-1000	250	3100	3325	3400	3513	3550	3580	3593
		High-speed mode	-300	100	400	625	700	813	850	880	893
$t_{SDASO}$ (slave)	$1t_{SCLL}^{*2} - 3t_{cyc}^{*2}$ ( $-t_{sr}$ )	Standard mode	-1000	250	3100	3325	3400	3513	3550	3580	3593
		High-speed mode	-300	100	400	625	700	813	850	880	893
$t_{SDAHO}$	$3t_{cyc}$	Standard mode	0	0	600	375	300	188	150	120	107
		High-speed mode	0	0	600	375	300	188	150	120	107

Notes: \*1 Does not meet the I<sup>2</sup>C bus interface specification. Remedial action such as the following is necessary: (a) secure a start/stop condition issuance interval; (b) adjust the rise and fall times by means of a pull-up resistor and capacitive load; (c) reduce the transfer rate; (d) select slave devices whose input timing permits this output timing.

The values in the above table will vary depending on the settings of the IICX bit and bits CKS0 to CKS2. Depending on the frequency it may not be possible to achieve the maximum transfer rate; therefore, whether or not the I<sup>2</sup>C bus interface specifications are met must be determined in accordance with the actual setting conditions.

\*2 Calculated using the I<sup>2</sup>C bus specification values (standard mode: 4700 ns min.; high-speed mode: 1300 ns min.).

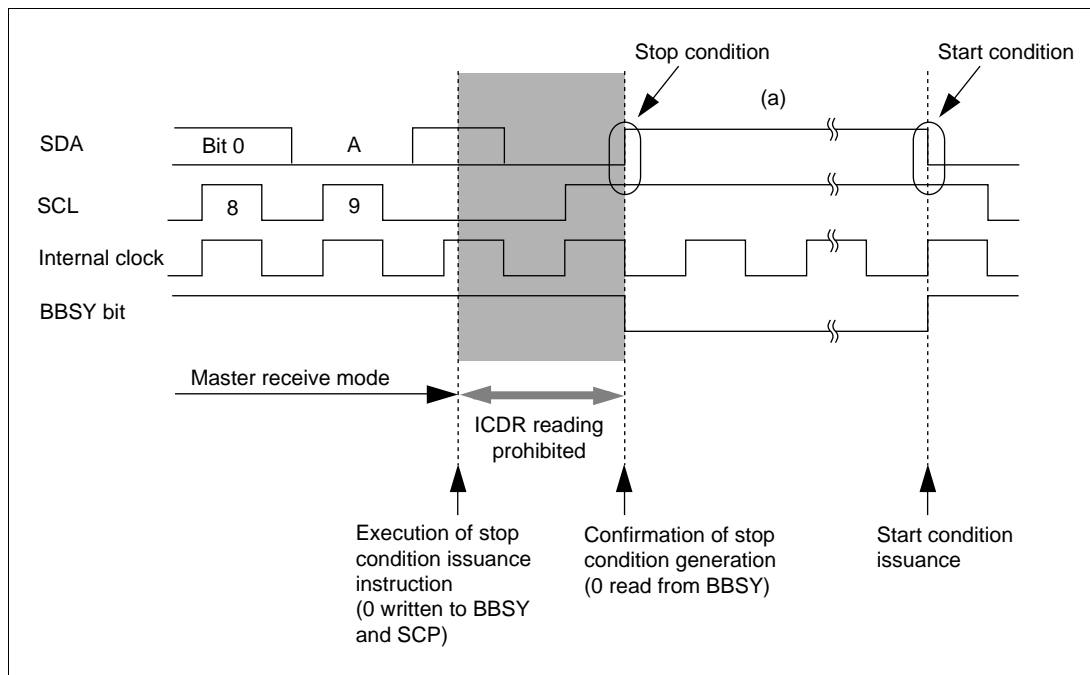
- Note on ICDR Read at End of Master Reception

To halt reception at the end of a receive operation in master receive mode, set the TRS bit to 1 and write 0 to BBSY and SCP in ICCR. This changes SDA from low to high when SCL is high, and generates the stop condition. After this, receive data can be read by means of an ICDR read, but if data remains in the buffer the ICDRS receive data will not be transferred to ICDR, and so it will not be possible to read the second byte of data.

If it is necessary to read the second byte of data, issue the stop condition in master receive mode (i.e. with the TRS bit cleared to 0). When reading the receive data, first confirm that the BBSY bit in the ICCR register is cleared to 0, the stop condition has been generated, and the bus has been released, then read the ICDR register with TRS cleared to 0.

Note that if the receive data (ICDR data) is read in the interval between execution of the instruction for issuance of the stop condition (writing of 0 to BBSY and SCP in ICCR) and the actual generation of the stop condition, the clock may not be output correctly in subsequent master transmission.

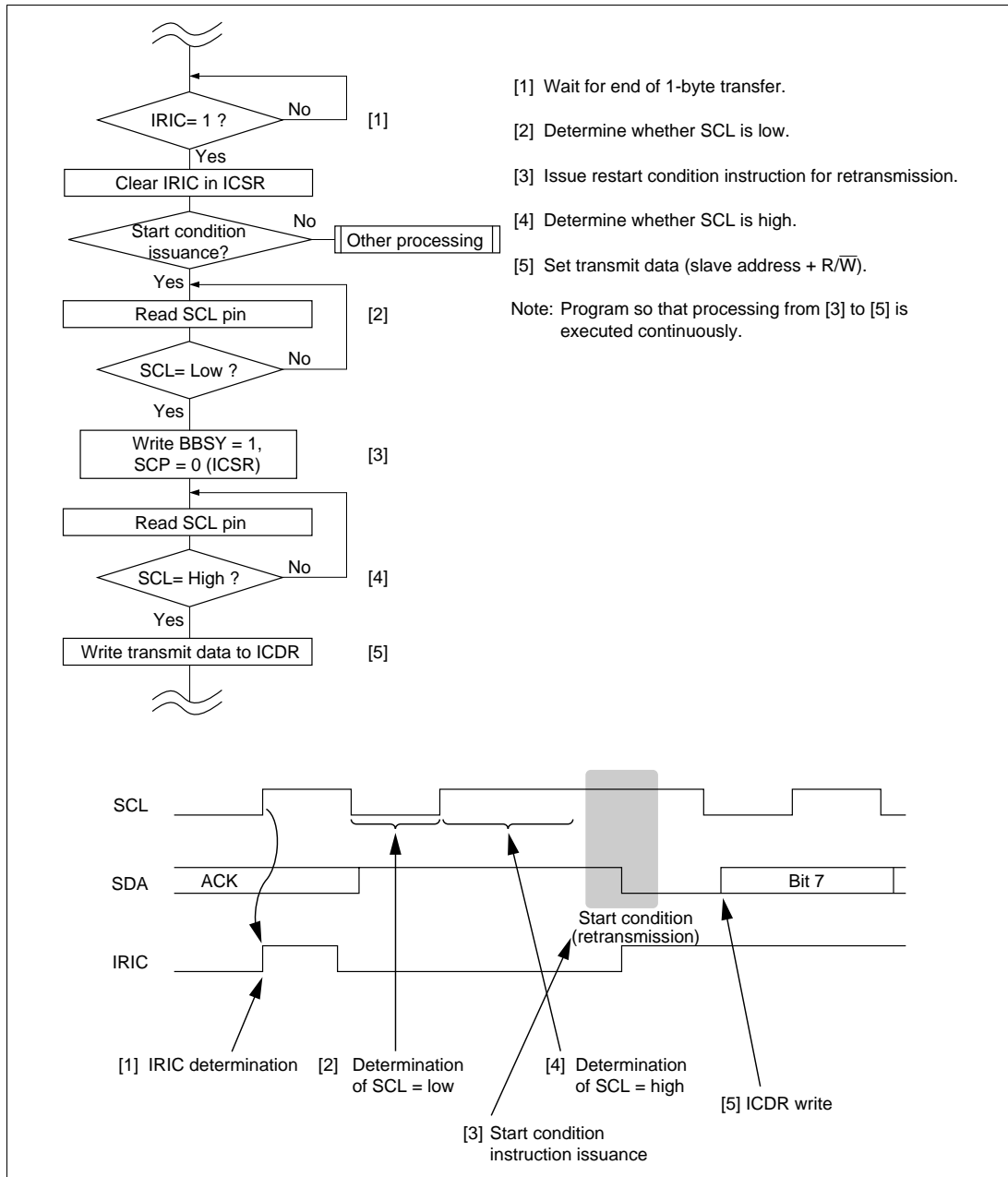
Clearing of the MST bit after completion of master transmission/reception, or other modifications of IIC control bits to change the transmit/receive operating mode or settings, must be carried out during interval (a) in figure 18-18 (after confirming that the BBSY bit has been cleared to 0 in the ICCR register).



**Figure 18-21 Points for Attention Concerning Reading of Master Receive Data**

- Notes on Start Condition Issuance for Retransmission

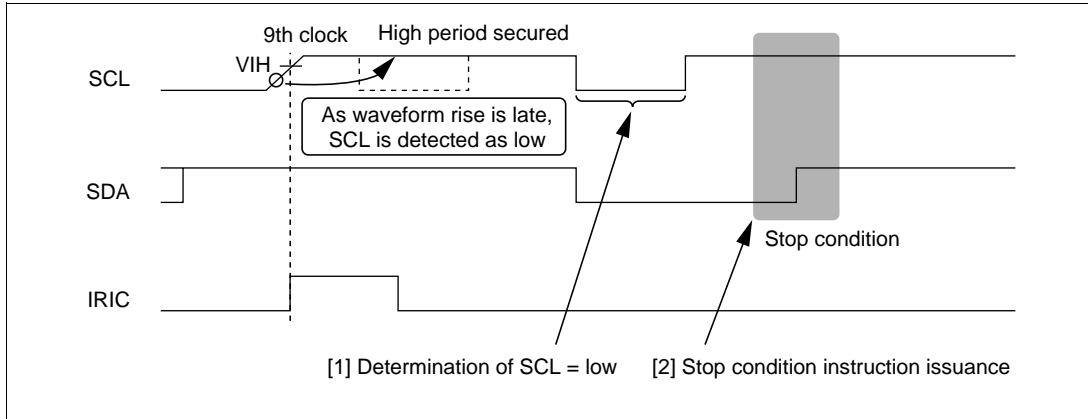
Figure 18-22 shows the timing of start condition issuance for retransmission, and the timing for subsequently writing data to ICDR, together with the corresponding flowchart.



**Figure 18-22 Flowchart and Timing of Start Condition Instruction Issuance for Retransmission**

- Notes on I<sup>2</sup>C Bus Interface Stop Condition Instruction Issuance

If the rise time of the 9th SCL acknowledge exceeds the specification because the bus load capacitance is large, or if there is a slave device of the type that drives SCL low to effect a wait, issue the stop condition instruction after reading SCL and determining it to be low, as shown below.

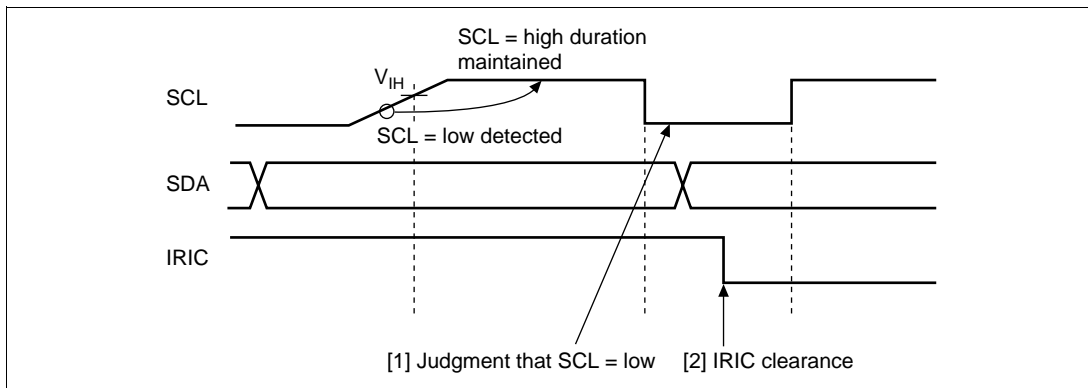


**Figure 18-23 Timing of Stop Condition Issuance**

- Notes on IRIC Flag Clearance when Using Wait Function

If the SCL rise time exceeds the designated duration or if the slave device is of the type that keeps SCL low and applies a wait state when the wait function is used in the master mode of the I<sup>2</sup>C bus interface, read SCL and clear the IRIC flag after determining that SCL has gone low, as shown below.

Clearing the IRIC flag to 0 when WAIT is set to 1 and SCL is being held at high level can cause the SDA value to change before SCL goes low, resulting in a start condition or stop condition being generated erroneously.



**Figure 18-24 IRIC Flag Clearance in WAIT = 1 Status**

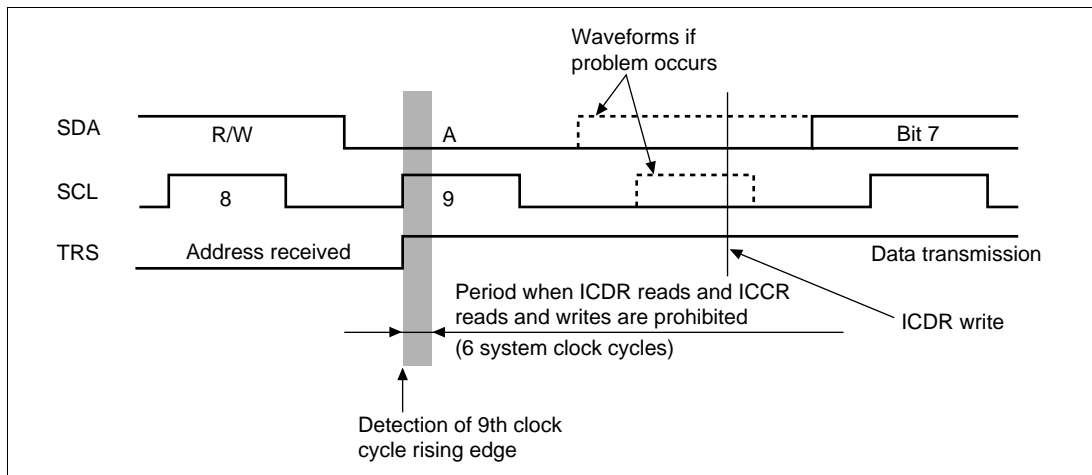
- Notes on ICDR Reads and ICCR Access in Slave Transmit Mode

In a transmit operation in the slave mode of the I<sup>2</sup>C bus interface, do not read the ICDR register or read or write to the ICCR register during the period indicated by the shaded portion in figure 18-25.

Normally, when interrupt processing is triggered in synchronization with the rising edge of the 9th clock cycle, the period in question has already elapsed when the transition to interrupt processing takes place, so there is no problem with reading the ICDR register or reading or writing to the ICCR register.

To ensure that the interrupt processing is performed properly, one of the following two conditions should be applied.

- (1) Make sure that reading received data from the ICDR register, or reading or writing to the ICCR register, is completed before the next slave address receive operation starts.
- (2) Monitor the BC2–BC0 counter in the ICMR register and, when the value of BC2–BC0 is 000 (8th or 9th clock cycle), allow a waiting time of at least 2 transfer clock cycles in order to involve the problem period in question before reading from the ICDR register, or reading or writing to the ICCR register.



**Figure 18-25 ICDR Read and ICCR Access Timing in Slave Transmit Mode**

- Notes on TRS Bit Setting in Slave Mode

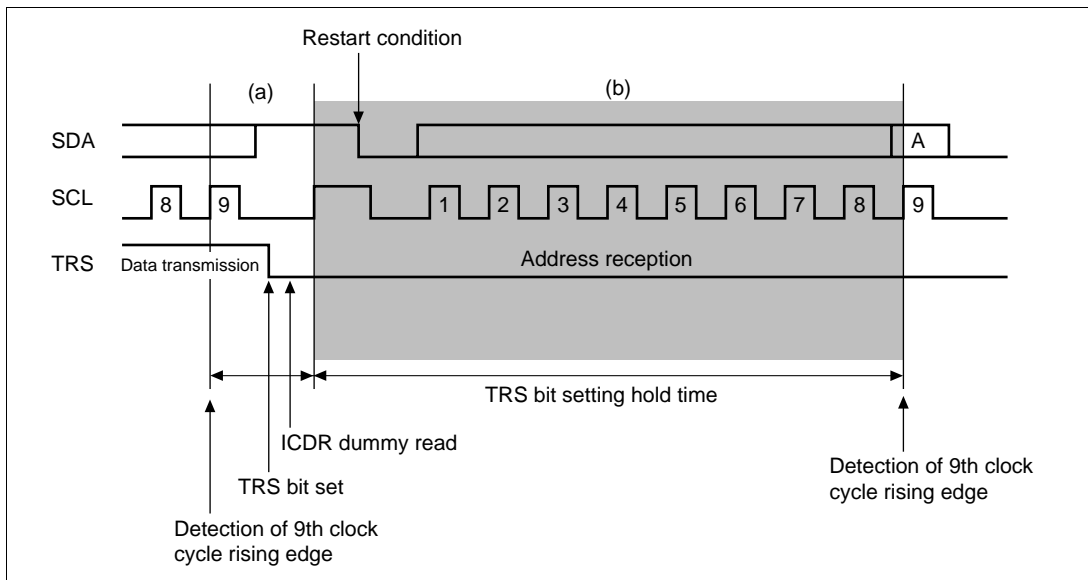
From the detection of the rising edge of the 9th clock cycle or of a stop condition to when the rising edge of the next SCL pin signal is detected (the period indicated as (a) in figure 18-26) in the slave mode of the I<sup>2</sup>C bus interface, the value set in the TRS bit in the ICCR register is effective immediately.

However, at other times (indicated as (b) in figure 18-26) the value set in the TRS bit is put on hold until the next rising edge of the 9th clock cycle or stop condition is detected, rather than taking effect immediately.

This results in the actual internal value of the TRS bit remaining 1 (transmit mode) and no acknowledge bit being sent at the 9th clock cycle address receive completion in the case of an address receive operation following a restart condition input with no stop condition intervening.

When receiving an address in the slave mode, clear the TRS bit to 0 during the period indicated as (a) in figure 18-26.

To cancel the holding of the SCL bit low by the wait function in the slave mode, clear the TRS bit to 0 and then perform a dummy read of the ICDR register.



**Figure 18-26 TRS Bit Setting Timing in Slave Mode**

- Notes on ICDR Reads in Transmit Mode and ICDR Writes in Receive Mode

When attempting to read ICDR in the transmit mode (TRS = 1) or write to ICDR in the receive mode (TRS = 0) under certain conditions, the SCL pin may not be held low after the completion of the transmit or receive operation and a clock may not be output to the SCL bus line before the ICDR register access operation can take place properly.

When accessing ICDR, always change the setting to the transmit mode before performing a read operation, and always change the setting to the receive mode before performing a write operation.

- Notes on ACKE Bit and TRS Bit in Slave Mode

When using the I<sup>2</sup>C bus interface, if an address is received in the slave mode immediately after 1 is received as an acknowledge bit (ACKB = 1) in the transmit mode (TRS = 1), an interrupt may be generated at the rising edge of the 9th clock cycle if the address does not match.

When performing slave mode operations using the IIC bus interface module, make sure to do the following.

- (1) When a 1 is received as an acknowledge bit for the final transmit data after completing a series of transmit operations, clear the ACKE bit in the ICCR register to 0 to initialize the ACKB bit to 0.
- (2) In the slave mode, change the setting to the receive mode (TRS = 0) before the start condition is input. To ensure that the switch from the slave transmit mode to the slave receive mode is accomplished properly, end the transmission as described in figure 18-19, Flowchart for Slave Transmit Mode (Example), in section 18.3.10, Sample Flowcharts.





## Section 19 A/D Converter

### 19.1 Overview

The H8S/2633 Series incorporates a successive approximation type 10-bit A/D converter that allows up to sixteen analog input channels to be selected.

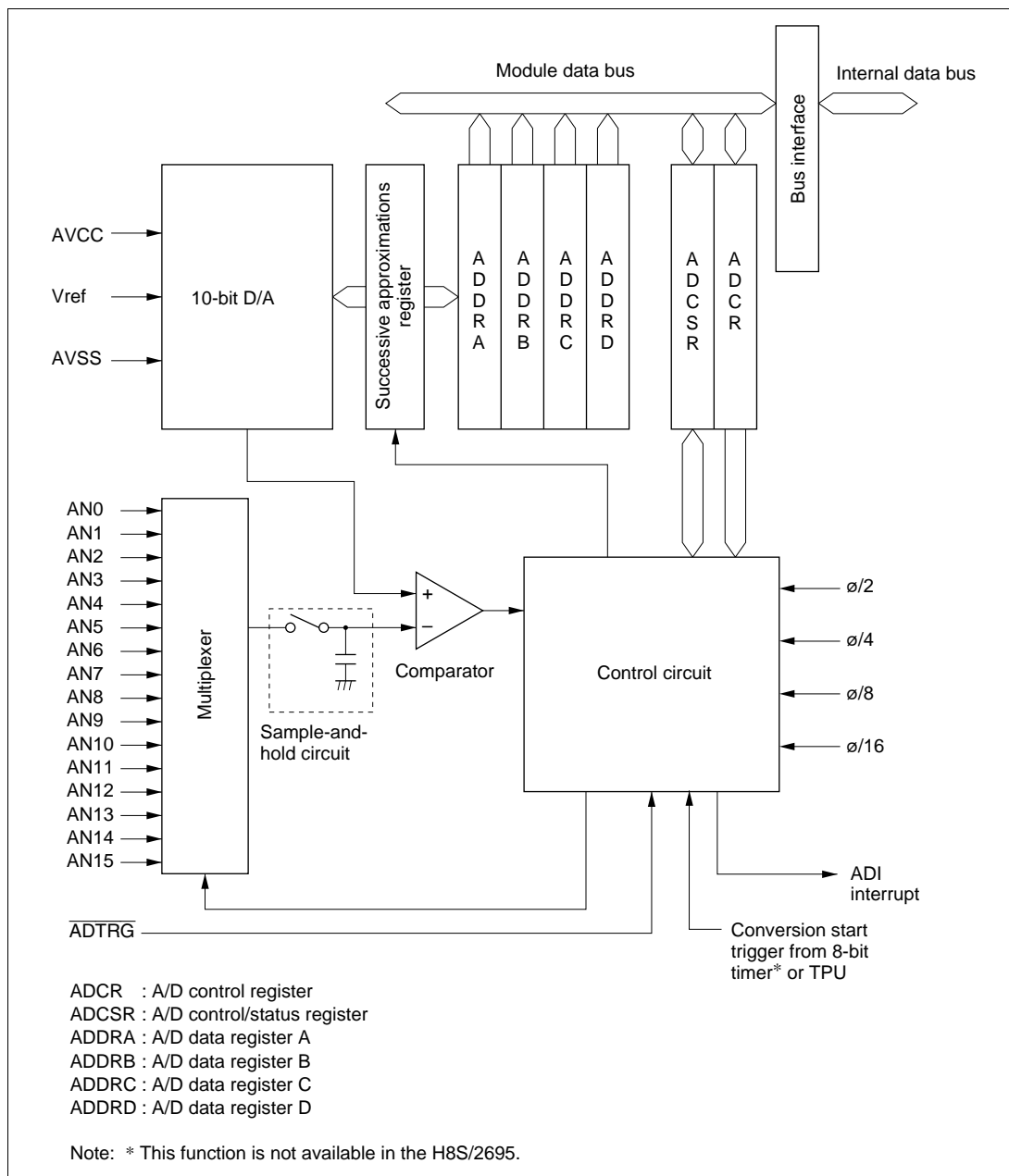
#### 19.1.1 Features

A/D converter features are listed below.

- 10-bit resolution
- Sixteen input channels
- Settable analog conversion voltage range
  - Conversion of analog voltages with the reference voltage pin (Vref) as the analog reference voltage
- High-speed conversion
  - Minimum conversion time:  
10.64  $\mu$ s per channel (at 25 MHz operation)
- Choice of single mode or scan mode
  - Single mode: Single-channel A/D conversion
  - Scan mode: Continuous A/D conversion on 1 to 4 channels
- Four data registers
  - Conversion results are held in a 16-bit data register for each channel
- Sample and hold function
- Three kinds of conversion start
  - Choice of software or timer conversion start trigger (TPU or 8-bit timer), or  $\overline{\text{ADTRG}}$  pin
- A/D conversion end interrupt generation
  - A/D conversion end interrupt (ADI) request can be generated at the end of A/D conversion
- Module stop mode can be set
  - As the initial setting, A/D converter operation is halted. Register access is enabled by exiting module stop mode.

### 19.1.2 Block Diagram

Figure 19-1 shows a block diagram of the A/D converter.



**Figure 19-1 Block Diagram of A/D Converter**

### 19.1.3 Pin Configuration

Table 19-1 summarizes the input pins used by the A/D converter.

The AVCC and AVSS pins are the power supply pins for the analog block in the A/D converter. The Vref pin is the A/D conversion reference voltage pin.

The 16 analog input pins are divided into two channel sets and two groups, with analog input pins 0 to 7 (AN0 to AN7) comprising channel set 0, analog input pins 8 to 15 (AN8 to AN15) comprising channel set 1, analog input pins 0 to 3 and 8 to 11 (AN0 to AN3, AN8 to AN11) comprising group 0, and analog input pins 4 to 7 and 12 to 15 (AN4 to AN7, AN12 to AN15) comprising group 1.

**Table 19-1 A/D Converter Pins**

Pin Name	Symbol	I/O	Function
Analog power supply pin	AVCC	Input	Analog block power supply
Analog ground pin	AVSS	Input	Analog block ground and reference voltage
Reference voltage pin	Vref	Input	A/D conversion reference voltage
Analog input pin 0	AN0	Input	Channel set 0 (CH3 = 0) group 0 analog inputs
Analog input pin 1	AN1	Input	
Analog input pin 2	AN2	Input	
Analog input pin 3	AN3	Input	
Analog input pin 4	AN4	Input	Channel set 0 (CH3 = 0) group 1 analog inputs
Analog input pin 5	AN5	Input	
Analog input pin 6	AN6	Input	
Analog input pin 7	AN7	Input	
Analog input pin 8	AN8	Input	Channel set 1 (CH3 = 1) group 0 analog inputs
Analog input pin 9	AN9	Input	
Analog input pin 10	AN10	Input	
Analog input pin 11	AN11	Input	
Analog input pin 12	AN12	Input	Channel set 1 (CH3 = 1) group 1 analog inputs
Analog input pin 13	AN13	Input	
Analog input pin 14	AN14	Input	
Analog input pin 15	AN15	Input	
A/D external trigger input pin	ADTRG	Input	External trigger input for starting A/D conversion

#### 19.1.4 Register Configuration

Table 19-2 summarizes the registers of the A/D converter.

**Table 19-2 A/D Converter Registers**

<b>Name</b>	<b>Abbreviation</b>	<b>R/W</b>	<b>Initial Value</b>	<b>Address*<sup>1</sup></b>
A/D data register AH	ADDRAH	R	H'00	H'FF90
A/D data register AL	ADDRAL	R	H'00	H'FF91
A/D data register BH	ADDRBH	R	H'00	H'FF92
A/D data register BL	ADDRBL	R	H'00	H'FF93
A/D data register CH	ADDRCH	R	H'00	H'FF94
A/D data register CL	ADDRCL	R	H'00	H'FF95
A/D data register DH	ADDRDH	R	H'00	H'FF96
A/D data register DL	ADDRDL	R	H'00	H'FF97
A/D control/status register	ADCSR	R/(W)* <sup>2</sup>	H'00	H'FF98
A/D control register	ADCR	R/W	H'33	H'FF99
Module stop control register A	MSTPCRA	R/W	H'3F	H'FDE8

Notes: \*1 Lower 16 bits of the address.

\*2 Bit 7 can only be written with 0 for flag clearing.

## 19.2 Register Descriptions

### 19.2.1 A/D Data Registers A to D (ADDRA to ADDR D)

Bit	:	15	14	13	12	11	10	9	8	7	6	5	4	3	2	1	0
		AD9	AD8	AD7	AD6	AD5	AD4	AD3	AD2	AD1	AD0	—	—	—	—	—	—
Initial value	:	0	0	0	0	0	0	0	0	0	0	0	0	0	0	0	0
R/W	:	R	R	R	R	R	R	R	R	R	R	R	R	R	R	R	R

There are four 16-bit read-only ADDR registers, ADDRA to ADDR D, used to store the results of A/D conversion.

The 10-bit data resulting from A/D conversion is transferred to the ADDR register for the selected channel and stored there. The upper 8 bits of the converted data are transferred to the upper byte (bits 15 to 8) of ADDR, and the lower 2 bits are transferred to the lower byte (bits 7 and 6) and stored. Bits 5 to 0 are always read as 0.

The correspondence between the analog input channels and ADDR registers is shown in table 19-3.

ADDR can always be read by the CPU. The upper byte can be read directly, but for the lower byte, data transfer is performed via a temporary register (TEMP). For details, see section 19.3, Interface to Bus Master.

The ADDR registers are initialized to H'0000 by a reset, and in standby mode or module stop mode.

**Table 19-3 Analog Input Channels and Corresponding ADDR Registers**

Analog Input Channel				
Channel Set 0 (CH3 = 0)		Channel Set 1 (CH3 = 1)		A/D Data Register
Group 0	Group 1	Group 0	Group 1	
AN0	AN4	AN8	AN12	ADDRA
AN1	AN5	AN9	AN13	ADDRB
AN2	AN6	AN10	AN14	ADDRC
AN3	AN7	AN11	AN15	ADDRD

### 19.2.2 A/D Control/Status Register (ADCSR)

Bit	:	7	6	5	4	3	2	1	0
		ADF	ADIE	ADST	SCAN	CH3	CH2	CH1	CH0
Initial value	:	0	0	0	0	0	0	0	0
R/W	:	R/(W)*	R/W	R/W	R/W	R/W	R/W	R/W	R/W

Note: \* Only 0 can be written to bit 7, to clear this flag.

ADCSR is an 8-bit readable/writable register that controls A/D conversion operations.

ADCSR is initialized to H'00 by a reset, and in hardware standby mode or module stop mode.

**Bit 7—A/D End Flag (ADF):** Status flag that indicates the end of A/D conversion.

#### Bit 7

ADF	Description
0	[Clearing conditions] (Initial value) <ul style="list-style-type: none"> <li>When 0 is written to the ADF flag after reading ADF = 1</li> <li>When the DTC* is activated by an ADI interrupt and ADDR is read</li> </ul>
1	[Setting conditions] <ul style="list-style-type: none"> <li>Single mode: When A/D conversion ends</li> <li>Scan mode: When A/D conversion ends on all specified channels</li> </ul>

Note: \* The DTC function is not available in the H8S/2695.

**Bit 6—A/D Interrupt Enable (ADIE):** Selects enabling or disabling of interrupt (ADI) requests at the end of A/D conversion.

#### Bit 6

ADIE	Description
0	A/D conversion end interrupt (ADI) request disabled (Initial value)
1	A/D conversion end interrupt (ADI) request enabled

**Bit 5—A/D Start (ADST):** Selects starting or stopping on A/D conversion. Holds a value of 1 during A/D conversion.

The ADST bit can be set to 1 by software, a timer conversion start trigger, or the A/D external trigger input pin ( $\overline{\text{ADTRG}}$ ).

**Bit 5**

ADST	Description
0	• A/D conversion stopped (Initial value)
1	<ul style="list-style-type: none"> <li>• Single mode: A/D conversion is started. Cleared to 0 automatically when conversion on the specified channel ends</li> <li>• Scan mode: A/D conversion is started. Conversion continues sequentially on the selected channels until ADST is cleared to 0 by software, a reset, or a transition to standby mode or module stop mode</li> </ul>

**Bit 4—Scan Mode (SCAN):** Selects single mode or scan mode as the A/D conversion operating mode. See section 19.4, Operation, for single mode and scan mode operation. Only set the SCAN bit while conversion is stopped (ADST = 0).

**Bit 4**

SCAN	Description
0	Single mode (Initial value)
1	Scan mode

**Bit 3—Channel Select 3 (CH3):** Switches the analog input pins assigned to group 0 or group 1. Setting CH3 to CH1 enables AN8 to AN15 to be used instead of AN0 to AN7.

**Bit 3**

CH3	Description
0	AN8 to AN11 are group 0 analog input pins, AN12 to AN15 are group 1 analog input pins
1	AN0 to AN3 are group 0 analog input pins, AN4 to AN7 are group 1 analog input pins (Initial value)

**Bits 2 to 0—Channel Select 2 to 0 (CH2 to CH0):** Together with the SCAN bit, these bits select the analog input channels.

Only set the input channel while conversion is stopped (ADST = 0).

Channel Selection				Description		
CH3	CH2	CH1	CH0	Single Mode (SCAN = 0)	Scan Mode (SCAN = 1)	
0	0	0	0	AN0 (Initial value)	AN0	
			1	AN1	AN0, AN1	
	1	0	0	AN2	AN0 to AN2	
			1	AN3	AN0 to AN3	
		1	0	0	AN4	AN4
	1	0	1	0	AN6	AN4 to AN6
				1	AN7	AN4 to AN7
1		0	0	AN8	AN8	
			1	AN9	AN8, AN9	
1	0	1	0	AN10	AN8 to AN10	
			1	AN11	AN8 to AN11	
	1	0	0	AN12	AN12	
			1	AN13	AN12, AN13	
		1	0	0	AN14	AN12 to AN14
			1	AN15	AN12 to AN15	



### 19.2.3 A/D Control Register (ADCR)

Bit	:	7	6	5	4	3	2	1	0
		TRGS1	TRGS0	—	—	CKS1	CKS0	—	—
Initial value	:	0	0	1	1	0	0	1	1
R/W	:	R/W	R/W	—	—	R/W	R/W	—	—

ADCR is an 8-bit readable/writable register that enables or disables external triggering of A/D conversion operations and sets the A/D conversion time.

ADCR is initialized to H'33 by a reset, and in standby mode or module stop mode.

**Bits 7 and 6—Timer Trigger Select 1 and 0 (TRGS1, TRGS0):** Select enabling or disabling of the start of A/D conversion by a trigger signal. Only set bits TRGS1 and TRGS0 while conversion is stopped (ADST = 0).

Bit 7	Bit 6	Description
TRGS1	TRGS0	Description
0	0	A/D conversion start by software is enabled (Initial value)
	1	A/D conversion start by TPU conversion start trigger is enabled
1	0	A/D conversion start by 8-bit timer* conversion start trigger is enabled
	1	A/D conversion start by external trigger pin ( $\overline{\text{ADTRG}}$ ) is enabled

Note: \* This function is not available in the H8S/2695.

**Bits 5, 4, 1, and 0—Reserved:** They are always read as 1 and cannot be modified.

**Bits 3 and 2—Clock Select 1 and 0 (CKS1, CKS0):** These bits select the A/D conversion time. The conversion time should be changed only when ADST = 0.

Set bits CKS1 and CKS0 to give a conversion time of at least 10  $\mu\text{s}$  when  $\text{AV}_{\text{CC}} \geq 4.5 \text{ V}$ , and at least 16  $\mu\text{s}$  when  $\text{AV}_{\text{CC}} < 4.5 \text{ V}$ .

Bit 3	Bit 2	Description
CKS1	CKS0	Description
0	0	Conversion time = 530 states (max.) (Initial value)
	1	Conversion time = 266 states (max.)
1	0	Conversion time = 134 states (max.)
	1	Conversion time = 68 states (max.)

### 19.2.4 Module Stop Control Register A (MSTPCRA)

Bit	:	7	6	5	4	3	2	1	0
		MSTPA7	MSTPA6	MSTPA5	MSTPA4	MSTPA3	MSTPA2	MSTPA1	MSTPA0
Initial value	:	0	0	1	1	1	1	1	1
R/W	:	R/W	R/W	R/W	R/W	R/W	R/W	R/W	R/W

MSTPCR is a 8-bit readable/writable register that performs module stop mode control.

When the MSTPA1 bit in MSTPCR is set to 1, A/D converter operation stops at the end of the bus cycle and a transition is made to module stop mode. Registers cannot be read or written to in module stop mode. For details, see section 24.5, Module Stop Mode.

MSTPCRA is initialized to H'3F by a reset and in hardware standby mode. It is not initialized by a manual reset and in software standby mode.

**Bit 1—Module Stop (MSTPA1):** Specifies the A/D converter module stop mode.

Bit 1	
MSTPA1	Description
0	A/D converter module stop mode cleared
1	A/D converter module stop mode set (Initial value)

### 19.3 Interface to Bus Master

ADDRA to ADDR<sub>D</sub> are 16-bit registers, and the data bus to the bus master is 8 bits wide. Therefore, in accesses by the bus master, the upper byte is accessed directly, but the lower byte is accessed via a temporary register (TEMP).

A data read from ADDR is performed as follows. When the upper byte is read, the upper byte value is transferred to the CPU and the lower byte value is transferred to TEMP. Next, when the lower byte is read, the TEMP contents are transferred to the CPU.

When reading ADDR, always read the upper byte before the lower byte. It is possible to read only the upper byte, but if only the lower byte is read, incorrect data may be obtained.

Figure 19-2 shows the data flow for ADDR access.

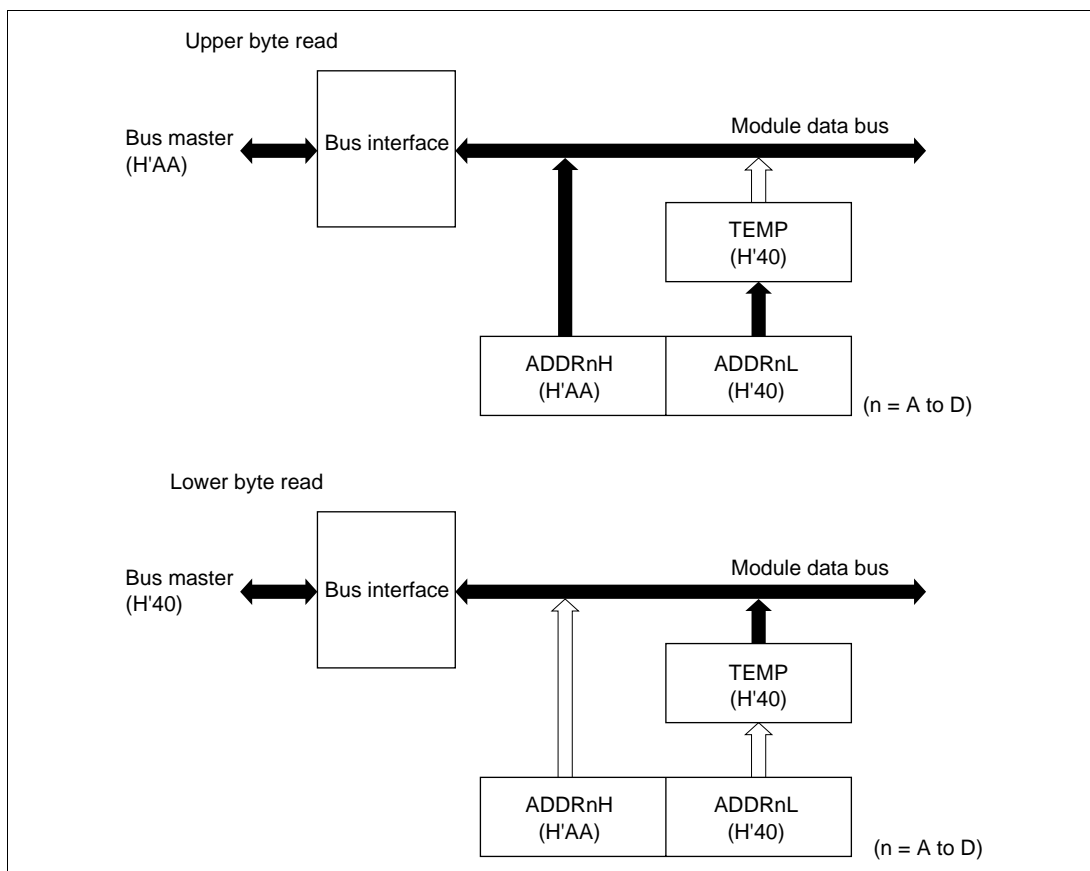


Figure 19-2 ADDR Access Operation (Reading H'AA40)

## 19.4 Operation

The A/D converter operates by successive approximation with 10-bit resolution. It has two operating modes: single mode and scan mode.

### 19.4.1 Single Mode (SCAN = 0)

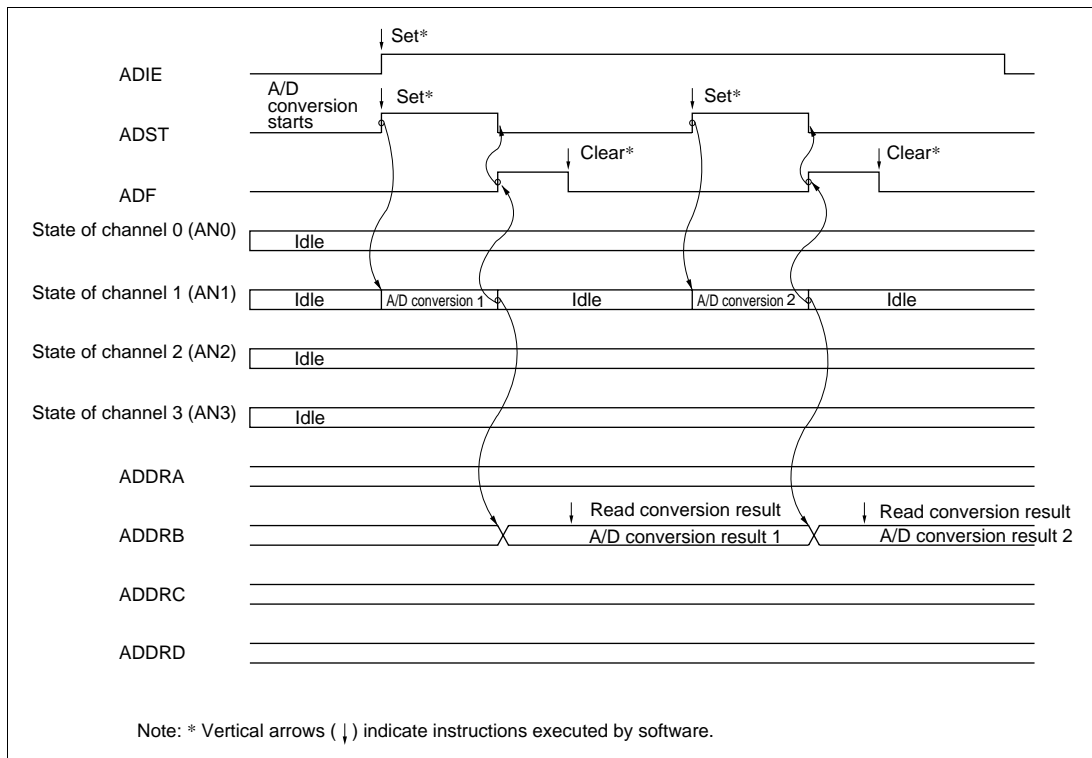
Single mode is selected when A/D conversion is to be performed on a single channel only. A/D conversion is started when the ADST bit is set to 1, according to the software or external trigger input. The ADST bit remains set to 1 during A/D conversion, and is automatically cleared to 0 when conversion ends.

On completion of conversion, the ADF flag is set to 1. If the ADIE bit is set to 1 at this time, an ADI interrupt request is generated. The ADF flag is cleared by writing 0 after reading ADCSR.

When the operating mode or analog input channel must be changed during analog conversion, to prevent incorrect operation, first clear the ADST bit to 0 in ADCSR to halt A/D conversion. After making the necessary changes, set the ADST bit to 1 to start A/D conversion again. The ADST bit can be set at the same time as the operating mode or input channel is changed.

Typical operations when channel 1 (AN1) is selected in single mode are described next. Figure 19-3 shows a timing diagram for this example.

- [1] Single mode is selected (SCAN = 0), input channel AN1 is selected (CH3 = 0, CH2 = 0, CH1 = 0, CH0 = 1), the A/D interrupt is enabled (ADIE = 1), and A/D conversion is started (ADST = 1).
- [2] When A/D conversion is completed, the result is transferred to ADDR0. At the same time the ADF flag is set to 1, the ADST bit is cleared to 0, and the A/D converter becomes idle.
- [3] Since ADF = 1 and ADIE = 1, an ADI interrupt is requested.
- [4] The A/D interrupt handling routine starts.
- [5] The routine reads ADCSR, then writes 0 to the ADF flag.
- [6] The routine reads and processes the conversion result (ADDR0).
- [7] Execution of the A/D interrupt handling routine ends. After that, if the ADST bit is set to 1, A/D conversion starts again and steps [2] to [7] are repeated.



**Figure 19-3 Example of A/D Converter Operation (Single Mode, Channel 1 Selected)**

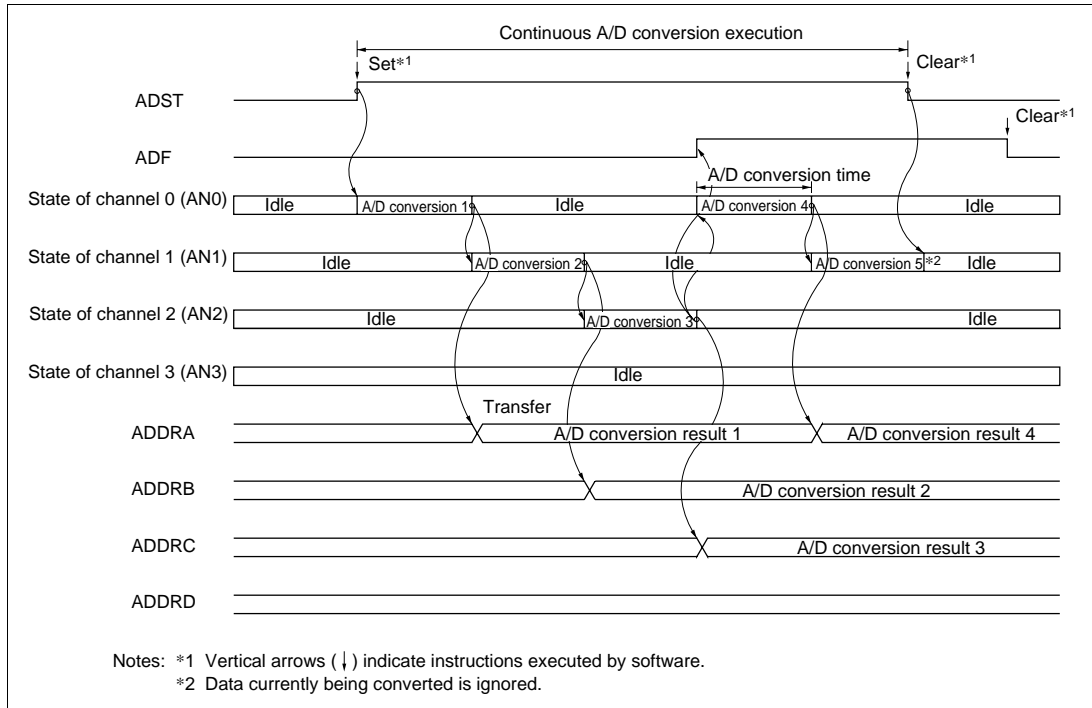
### 19.4.2 Scan Mode (SCAN = 1)

Scan mode is useful for monitoring analog inputs in a group of one or more channels. When the ADST bit is set to 1 by a software, timer or external trigger input, A/D conversion starts on the first channel in the group (AN0). When two or more channels are selected, after conversion of the first channel ends, conversion of the second channel (AN1) starts immediately. A/D conversion continues cyclically on the selected channels until the ADST bit is cleared to 0. The conversion results are transferred for storage into the ADDR registers corresponding to the channels.

When the operating mode or analog input channel must be changed during analog conversion, to prevent incorrect operation, first clear the ADST bit to 0 in ADCSR to halt A/D conversion. After making the necessary changes, set the ADST bit to 1 to start A/D conversion again from the first channel (AN0). The ADST bit can be set at the same time as the operating mode or input channel is changed.

Typical operations when three channels (AN0 to AN2) are selected in scan mode are described next. Figure 19-4 shows a timing diagram for this example.

- [1] Scan mode is selected (SCAN = 1), channel set 0 is selected (CH3 = 0), scan group 0 is selected (CH2 = 0), analog input channels AN0 to AN2 are selected (CH1 = 1, CH0 = 0), and A/D conversion is started (ADST = 1).
- [2] When A/D conversion of the first channel (AN0) is completed, the result is transferred to ADDR0. Next, conversion of the second channel (AN1) starts automatically.
- [3] Conversion proceeds in the same way through the third channel (AN2).
- [4] When conversion of all the selected channels (AN0 to AN2) is completed, the ADF flag is set to 1 and conversion of the first channel (AN0) starts again. If the ADIE bit is set to 1 at this time, an ADI interrupt is requested after A/D conversion ends.
- [5] Steps [2] to [4] are repeated as long as the ADST bit remains set to 1. When the ADST bit is cleared to 0, A/D conversion stops. After that, if the ADST bit is set to 1, A/D conversion starts again from the first channel (AN0).



**Figure 19-4 Example of A/D Converter Operation  
 (Scan Mode, 3 Channels AN0 to AN2 Selected)**

### 19.4.3 Input Sampling and A/D Conversion Time

The A/D converter has a built-in sample-and-hold circuit. The A/D converter samples the analog input at a time  $t_D$  after the ADST bit is set to 1, then starts conversion. Figure 19-5 shows the A/D conversion timing. Table 19-4 indicates the A/D conversion time.

As indicated in figure 19-5, the A/D conversion time includes  $t_D$  and the input sampling time. The length of  $t_D$  varies depending on the timing of the write access to ADCSR. The total conversion time therefore varies within the ranges indicated in table 19-4.

In scan mode, the values given in table 19-4 apply to the first conversion time. The values given in table 19-5 apply to the second and subsequent conversions. In both cases, set bits CKS1 and CKS0 in ADCR to give a conversion time of at least 10  $\mu\text{s}$  when  $AV_{CC} \geq 4.5\text{ V}$ , and at least 16  $\mu\text{s}$  when  $AV_{CC} < 4.5\text{ V}$ .

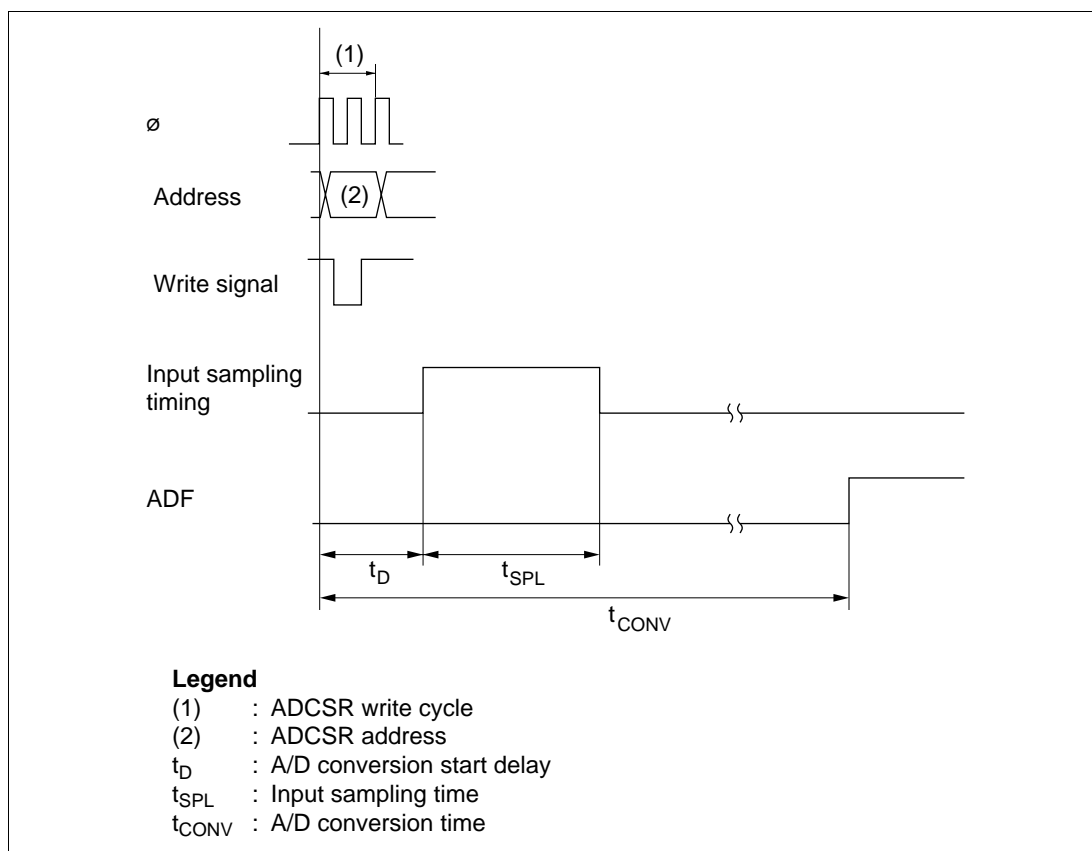


Figure 19-5 A/D Conversion Timing



**Table 19-4 A/D Conversion Time (Single Mode)**

Item	Symbol	CKS1 = 0						CKS1 = 1					
		CKS0 = 0			CKS0 = 1			CKS0 = 0			CKS0 = 1		
		Min	Typ	Max	Min	Typ	Max	Min	Typ	Max	Min	Typ	Max
A/D conversion start delay $t_D$		18	—	33	10	—	17	6	—	9	4	—	5
Input sampling time	$t_{SPL}$	—	127	—	—	63	—	—	31	—	—	15	—
A/D conversion time	$t_{CONV}$	515	—	530	259	—	266	131	—	134	67	—	68

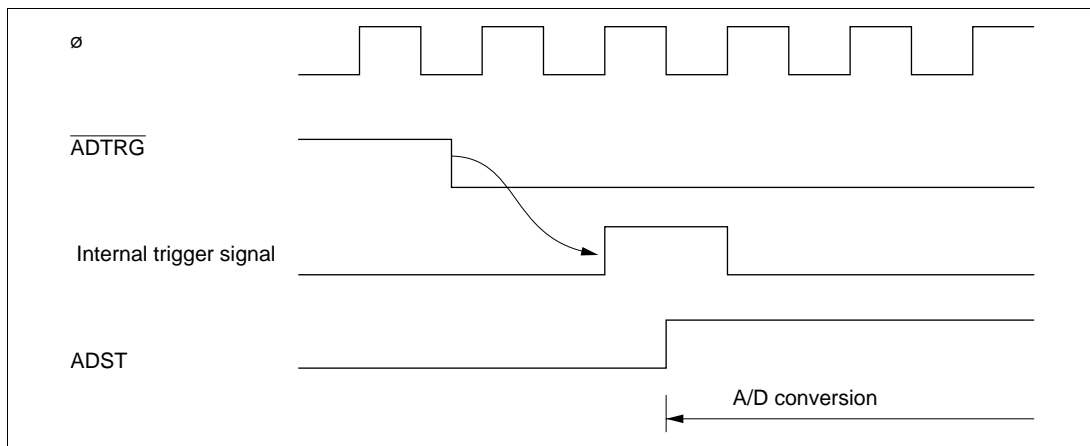
Note: Values in the table are the number of states.

**Table 19-5 A/D Conversion Time (Scan Mode)**

CKS1	CKS0	Conversion Time (State)
0	0	512 (Fixed)
	1	256 (Fixed)
1	0	128 (Fixed)
	1	64 (Fixed)

#### 19.4.4 External Trigger Input Timing

A/D conversion can be externally triggered. When the TRGS1 and TRGS0 bits are set to 11 in ADCR, external trigger input is enabled at the ADTRG pin. A falling edge at the ADTRG pin sets the ADST bit to 1 in ADCSR, starting A/D conversion. Other operations, in both single and scan modes, are the same as if the ADST bit has been set to 1 by software. Figure 19-6 shows the timing.



**Figure 19-6 External Trigger Input Timing**

## 19.5 Interrupts

The A/D converter generates an A/D conversion end interrupt (ADI) at the end of A/D conversion. ADI interrupt requests can be enabled or disabled by means of the ADIE bit in ADCSR.

The DTC\* and DMAC\* can be activated by an ADI interrupt. Having the converted data read by the DTC\* or DMAC\* in response to an ADI interrupt enables continuous conversion to be achieved without imposing a load on software.

The A/D converter interrupt source is shown in table 19-6.

Note: \* This function is not available in the H8S/2695.

**Table 19-6 A/D Converter Interrupt Source**

Interrupt Source	Description	DTC*, DMAC* Activation
ADI	Interrupt due to end of conversion	Possible

Note: \* This function is not available in the H8S/2695.

## 19.6 Usage Notes

The following points should be noted when using the A/D converter.

### Setting Range of Analog Power Supply and Other Pins:

(1) Analog input voltage range

The voltage applied to analog input pin ANn during A/D conversion should be in the range  $AVSS \leq ANn \leq Vref$ .

(2) Relation between AVCC, AVSS and VCC, VSS

As the relationship between AVCC, AVSS and VCC, VSS, set  $AVSS = VSS$ . If the A/D converter is not used, the AVCC and AVSS pins must on no account be left open.

(3) Vref input range

The analog reference voltage input at the Vref pin set in the range  $Vref \leq AVCC$ .

If conditions (1), (2), and (3) above are not met, the reliability of the device may be adversely affected.

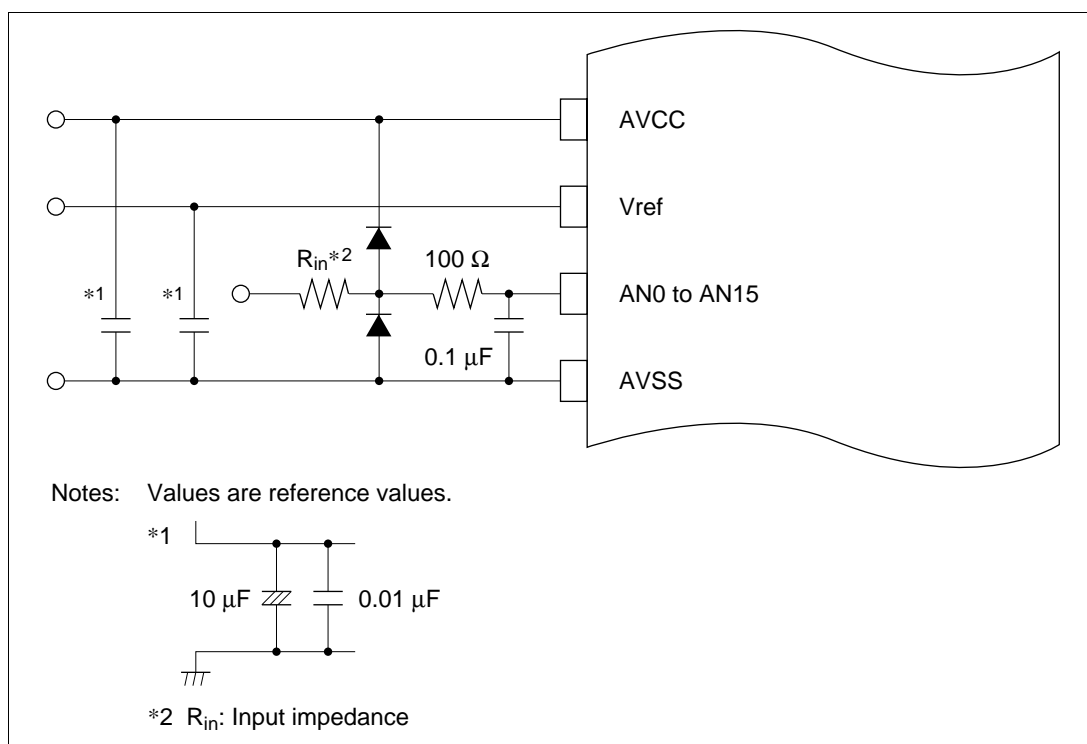
**Notes on Board Design:** In board design, digital circuitry and analog circuitry should be as mutually isolated as possible, and layout in which digital circuit signal lines and analog circuit signal lines cross or are in close proximity should be avoided as far as possible. Failure to do so may result in incorrect operation of the analog circuitry due to inductance, adversely affecting A/D conversion values.

Also, digital circuitry must be isolated from the analog input signals (AN0 to AN15), analog reference power supply (Vref), and analog power supply (AVCC) by the analog ground (AVSS). Also, the analog ground (AVSS) should be connected at one point to a stable digital ground (VSS) on the board.

**Notes on Noise Countermeasures:** A protection circuit connected to prevent damage due to an abnormal voltage such as an excessive surge at the analog input pins (AN0 to AN15) and analog reference power supply (Vref) should be connected between AVCC and AVSS as shown in figure 19-7.

Also, the bypass capacitors connected to AVCC and Vref and the filter capacitor connected to AN0 to AN15 must be connected to AVSS.

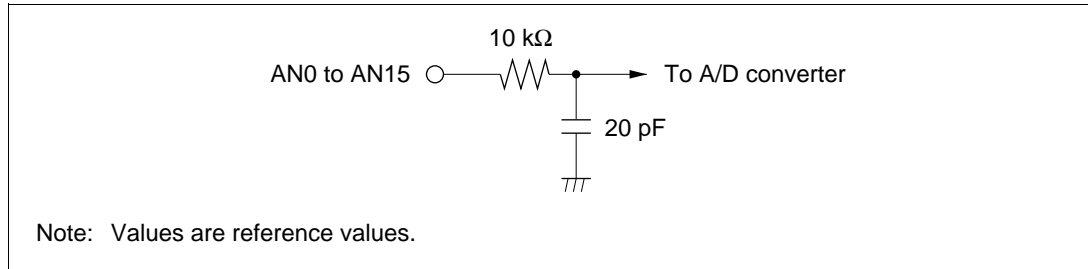
If a filter capacitor is connected as shown in figure 19-7, the input currents at the analog input pins (AN0 to AN15) are averaged, and so an error may arise. Also, when A/D conversion is performed frequently, as in scan mode, if the current charged and discharged by the capacitance of the sample-and-hold circuit in the A/D converter exceeds the current input via the input impedance ( $R_{in}$ ), an error will arise in the analog input pin voltage. Careful consideration is therefore required when deciding the circuit constants.



**Figure 19-7 Example of Analog Input Protection Circuit**

**Table 19-7 Analog Pin Specifications**

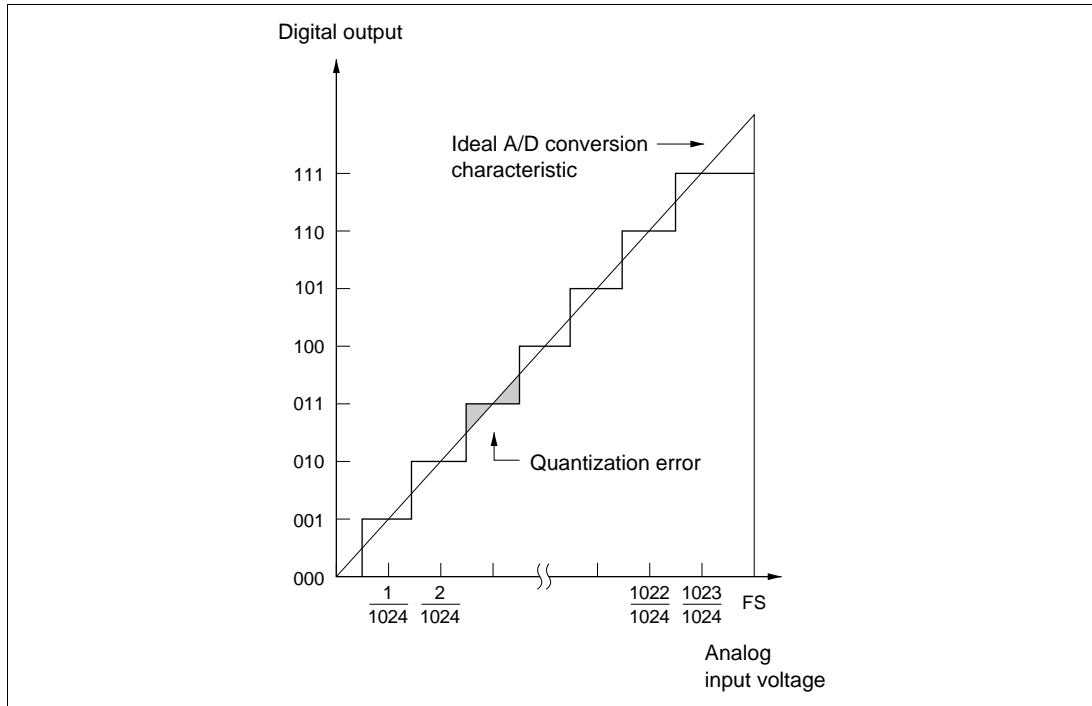
Item	Min	Max	Unit
Analog input capacitance	—	20	pF
Permissible signal source impedance	—	5	kΩ



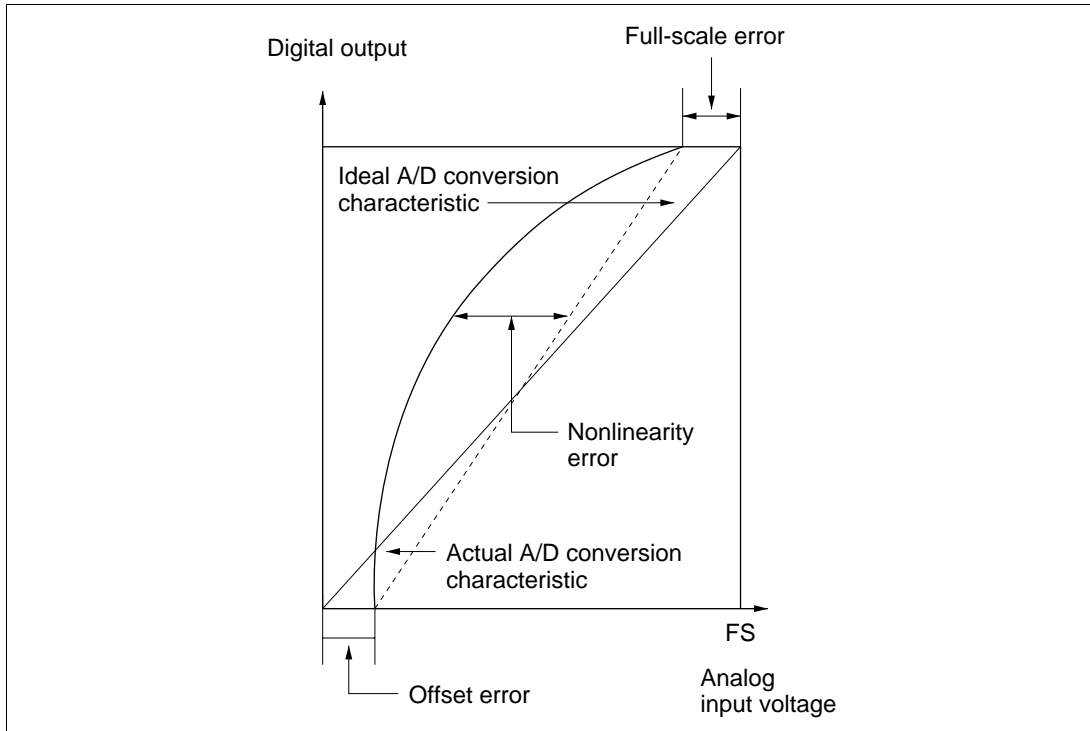
**Figure 19-8 Analog Input Pin Equivalent Circuit**

**A/D Conversion Precision Definitions:** H8S/2633 Series A/D conversion precision definitions are given below.

- Resolution  
The number of A/D converter digital output codes
- Offset error  
The deviation of the analog input voltage value from the ideal A/D conversion characteristic when the digital output changes from the minimum voltage value B'0000000000 (H'00) to B'0000000001 (H'01) (see figure 19-10).
- Full-scale error  
The deviation of the analog input voltage value from the ideal A/D conversion characteristic when the digital output changes from B'1111111110 (H'3E) to B'1111111111 (H'3F) (see figure 19-10).
- Quantization error  
The deviation inherent in the A/D converter, given by 1/2 LSB (see figure 19-9).
- Nonlinearity error  
The error with respect to the ideal A/D conversion characteristic between the zero voltage and the full-scale voltage. Does not include the offset error, full-scale error, or quantization error.
- Absolute precision  
The deviation between the digital value and the analog input value. Includes the offset error, full-scale error, quantization error, and nonlinearity error.



**Figure 19-9 A/D Conversion Precision Definitions (1)**



**Figure 19-10 A/D Conversion Precision Definitions (2)**

**Permissible Signal Source Impedance:** H8S/2633 Series analog input is designed so that conversion precision is guaranteed for an input signal for which the signal source impedance is 5 kΩ or less. This specification is provided to enable the A/D converter's sample-and-hold circuit input capacitance to be charged within the sampling time; if the sensor output impedance exceeds 10 kΩ, charging may be insufficient and it may not be possible to guarantee the A/D conversion precision.

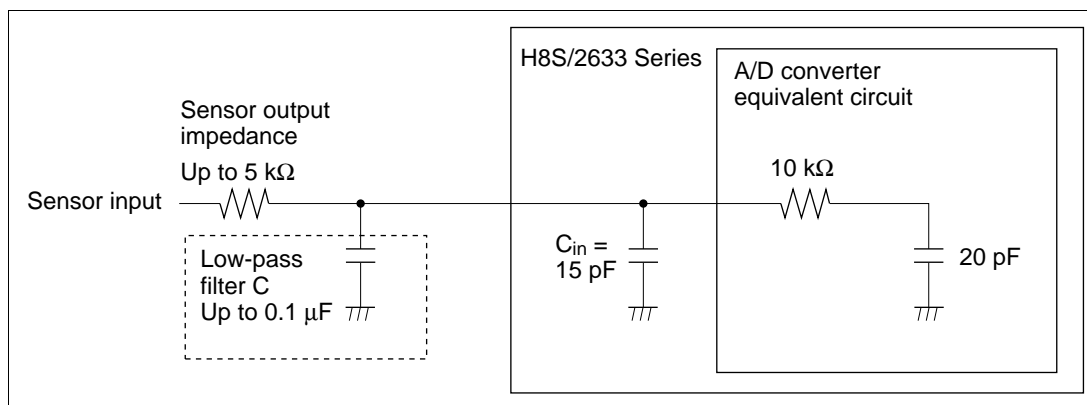
However, if a large capacitance is provided externally, the input load will essentially comprise only the internal input resistance of 10 kΩ, and the signal source impedance is ignored.

However, since a low-pass filter effect is obtained in this case, it may not be possible to follow an analog signal with a large differential coefficient (e.g., 5 mV/μs or greater).

When converting a high-speed analog signal, a low-impedance buffer should be inserted.

**Influences on Absolute Precision:** Adding capacitance results in coupling with GND, and therefore noise in GND may adversely affect absolute precision. Be sure to make the connection to an electrically stable GND such as AVSS.

Care is also required to insure that filter circuits do not communicate with digital signals on the mounting board, so acting as antennas.



**Figure 19-11 Example of Analog Input Circuit**





## Section 20 D/A Converter

(This function is not available in the H8S/2695)

### 20.1 Overview

The H8S/2633 Series has an on-chip D/A converter module with four channels.

#### 20.1.1 Features

Features of the D/A converter module are listed below.

- Eight-bit resolution
  - Four-channel output
  - Maximum conversion time: 10  $\mu$ s (with 20-pF load capacitance)
  - Output voltage: 0 V to Vref
  - D/A output retention in software standby mode
  - Possible to set module stop mode
- Operation of D/A converter is disabled by initial values. It is possible to access the register by canceling module stop mode.

#### 20.1.2 Block Diagram

Figure 20-1 shows a block diagram of the D/A converter.

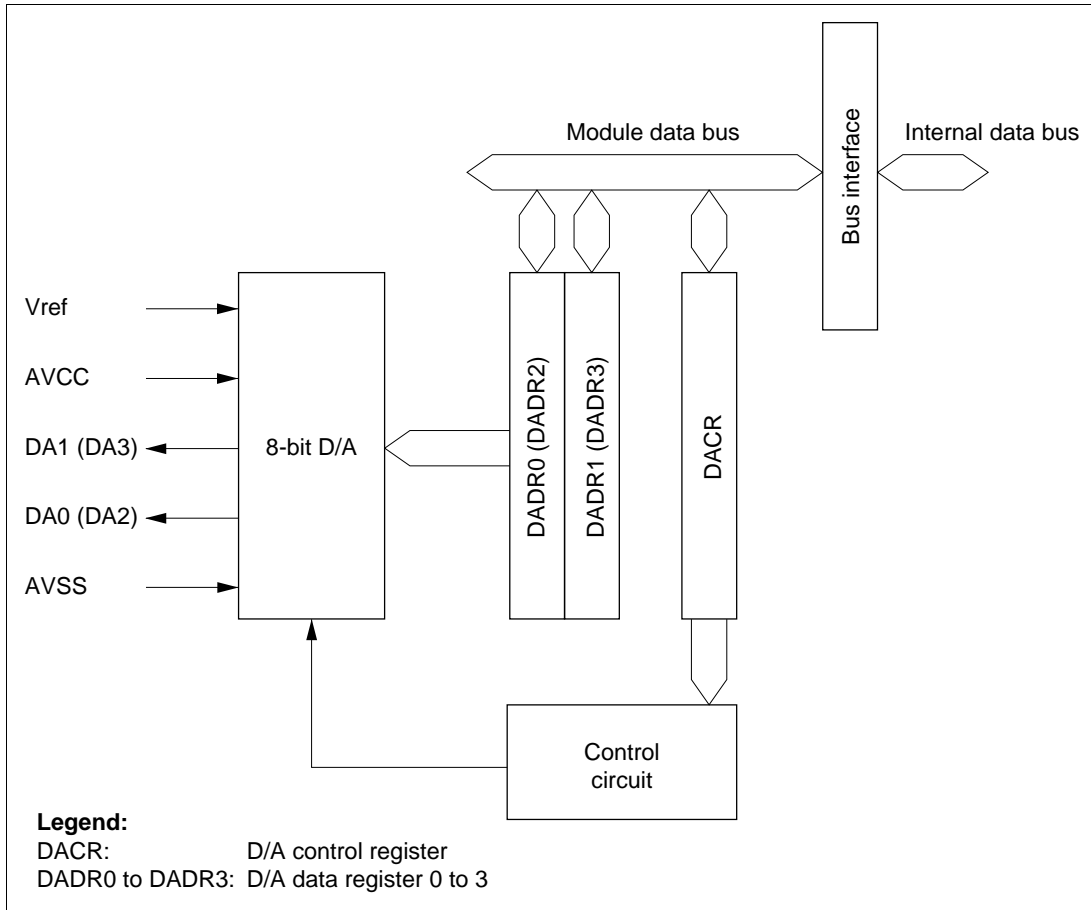


Figure 20-1 Block Diagram of D/A Converter

### 20.1.3 Input and Output Pins

Table 20-1 lists the input and output pins used by the D/A converter module.

**Table 20-1 Input and Output Pins of D/A Converter Module**

Name	Abbreviation	I/O	Function
Analog supply voltage	AVCC	Input	Power supply for analog circuits
Analog ground	AVSS	Input	Ground and reference voltage for analog circuits
Analog output 0	DA0	Output	Analog output channel 0
Analog output 1	DA1	Output	Analog output channel 1
Analog output 2	DA2	Output	Analog output channel 2
Analog output 3	DA3	Output	Analog output channel 3
Reference voltage	Vref	Input	Reference voltage of analog section

### 20.1.4 Register Configuration

Table 20-2 lists the registers of the D/A converter module.

**Table 20-2 D/A Converter Registers**

Channel	Name	Abbreviation	R/W	Initial Value	Address*
0, 1	D/A data register 0	DADR0	R/W	H'00	H'FFA4
	D/A data register 1	DADR1	R/W	H'00	H'FFA5
	D/A control register 01	DACR01	R/W	H'1F	H'FFA6
2, 3	D/A data register 2	DADR2	R/W	H'00	H'FDAC
	D/A data register 3	DADR3	R/W	H'00	H'FDAD
	D/A control register 23	DACR23	R/W	H'1F	H'FDAE
All	Module stop control register A	MSTPCRA	R/W	H'3F	H'FDF8
	Module stop control register C	MSTPCRC	R/W	H'FF	H'FDEA

Note: \* Lower 16 bits of the address.

## 20.2 Register Descriptions

### 20.2.1 D/A Data Registers 0 to 3 (DADR0 to DADR3)

Bit	:	7	6	5	4	3	2	1	0
Initial value	:	0	0	0	0	0	0	0	0
R/W	:	R/W	R/W	R/W	R/W	R/W	R/W	R/W	R/W

D/A data registers 0 to 3 (DADR0 to DADR3) are 8-bit readable/writable registers that store data to be converted. When analog output is enabled, the value in the D/A data register is converted and output continuously at the analog output pin.

The D/A data registers are initialized to H'00 by a reset and in hardware standby mode.

### 20.2.2 D/A Control Register 01 and 23 (DACR01 and DACR23)

Bit	:	7	6	5	4	3	2	1	0
		DAOE1	DAOE0	DAE	—	—	—	—	—
Initial value	:	0	0	0	1	1	1	1	1
R/W	:	R/W	R/W	R/W	—	—	—	—	—

DACR01 and DACR23 are an 8-bit readable/writable register that controls the operation of the D/A converter module.

DACR01 and DACR23 are initialized to H'1F by a reset and in hardware standby mode.

**Bit 7—D/A Output Enable 1 (DAOE1):** Controls D/A conversion and analog output.

Bit 7 DAOE1	Description
0	Analog output DA1 (DA3) is disabled (Initial value)
1	D/A conversion is enabled on channel 1. Analog output DA1 (DA3) is enabled

**Bit 6—D/A Output Enable 0 (DAOE0):** Controls D/A conversion and analog output.

**Bit 6**

DAOE0	Description
0	Analog output DA0 (DA2) is disabled (Initial value)
1	D/A conversion is enabled on channel 0. Analog output DA0 (DA2) is enabled

**Bit 5—D/A Enable (DAE):** Controls D/A conversion, in combination with bits DAOE0 and DAOE1. D/A conversion is controlled independently on channels 0 and 1 when DAE = 0. Channels 0 and 1 are controlled together when DAE = 1.

Output of the converted results is always controlled independently by DAOE0 and DAOE1.

Bit 7 DAOE1	Bit 6 DAOE0	Bit 5 DAE	D/A conversion
0	0	*	Disabled on channels 0 and 1 (channels 2 and 3)
	1	0	Enabled on channel 0 (channel 2)
		1	Enabled on channels 0 and 1 (channels 2 and 3)
1	0	0	Disabled on channel 0 (channel 2)
			Enabled on channel 1 (channel 3)
		1	Enabled on channels 0 and 1 (channels 2 and 3)
	1	*	Enabled on channels 0 and 1 (channels 2 and 3)

\*: Don't care

If the H8S/2633 Series chip enters software standby mode while D/A conversion is enabled, the D/A output is retained and the analog power supply current is the same as during D/A conversion. If it is necessary to reduce the analog power supply current in software standby mode, disable D/A output by clearing both the DAOE0 and DAOE1 bits to 0.

**Bits 4 to 0—Reserved:** These bits cannot be modified and are always read as 1.

### 20.2.3 Module Stop Control Register A and C (MSTPCRA and MSTPCRC)

#### MSTPCRA

Bit	:	7	6	5	4	3	2	1	0
		MSTPA7	MSTPA6	MSTPA5	MSTPA4	MSTPA3	MSTPA2	MSTPA1	MSTPA0
Initial value	:	0	0	1	1	1	1	1	1
R/W	:	R/W	R/W	R/W	R/W	R/W	R/W	R/W	R/W

#### MSTPCRC

Bit	:	7	6	5	4	3	2	1	0
		MSTPC7	MSTPC6	MSTPC5	MSTPC4	MSTPC3	MSTPC2	MSTPC1	MSTPC0
Initial value	:	1	1	1	1	1	1	1	1
R/W	:	R/W	R/W	R/W	R/W	R/W	R/W	R/W	R/W

MSTPCRA and MSTPCRC are an 8-bit readable/writable registers that performs module stop mode control. When the MSTPA2 and MSTPC5 are set to 1, the D/A converter halts and enters module stop mode at the end of the bus cycle. Register read/write is disabled in module stop mode. See section 24.5, Module Stop Mode, for details.

MSTPCRA is initialized to H'3F by a power-on reset and in hardware standby mode. MSTPCRC is initialized to H'FF by a power-on reset and in hardware standby mode. It is not initialized by a manual reset and in software standby mode.

### Module Stop Control Register A (MSTPCRA)

**Bit 2—Module Stop (MSTPA2):** Specifies D/A converter (channels 0 and 1) module stop mode.

#### Bit 2

<b>MSTPA2</b>	<b>Description</b>
0	D/A converter (channels 0 and 1) module stop mode is cleared
1	D/A converter (channels 0 and 1) module stop mode is set (Initial value)

### Module Stop Control Register C (MSTPCRC)

**Bit 5—Module Stop (MSTPC5):** Specifies D/A converter (channels 2 and 3) module stop mode.

#### Bit 5

<b>MSTPC5</b>	<b>Description</b>
0	D/A converter (channels 2 and 3) module stop mode is cleared
1	D/A converter (channels 2 and 3) module stop mode is set (Initial value)

## 20.3 Operation

The D/A converter module has two built-in D/A converter circuits that can operate independently.

D/A conversion is performed continuously whenever enabled by the D/A control register (DACR). When a new value is written in DADR0 or DADR1, conversion of the new value begins immediately. The converted result is output by setting the DAOE0 or DAOE1 bit to 1.

An example of conversion on channel 0 is given next. Figure 20-2 shows the timing.

- Software writes the data to be converted in DADR0.
- D/A conversion begins when the DAOE0 bit in DACR is set to 1. After the elapse of the conversion time, analog output appears at the DA0 pin. The output value is  $V_{ref} \times (\text{DADR0 value})/256$ .

This output continues until a new value is written in DADR0 or the DAOE0 bit is cleared to 0.

- If a new value is written in DADR0, conversion begins immediately. Output of the converted result begins after the conversion time.
- When the DAOE0 bit is cleared to 0, DA0 becomes an input pin.

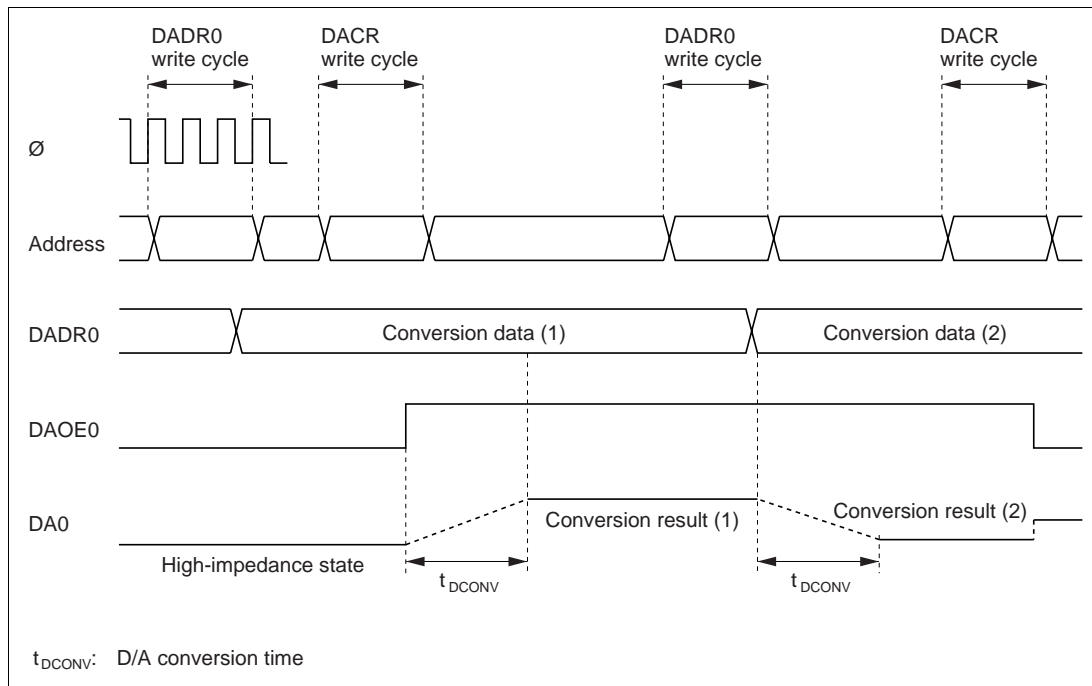


Figure 20-2 D/A Conversion (Example)



## Section 21 RAM

### 21.1 Overview

The H8S/2633 and H8S/2633R have 16 kbytes of on-chip high-speed static RAM, the H8S/2632 has 12 kbytes, and the H8S/2631 and H8S/2695 have 8 kbytes. The RAM is connected to the CPU by a 16-bit data bus, enabling one-state access by the CPU to both byte data and word data. This makes it possible to perform fast word data transfer.

The on-chip RAM can be enabled or disabled by means of the RAM enable bit (RAME) in the system control register (SYSCR).

#### 21.1.1 Block Diagram

Figure 21-1 shows a block diagram of the on-chip RAM.

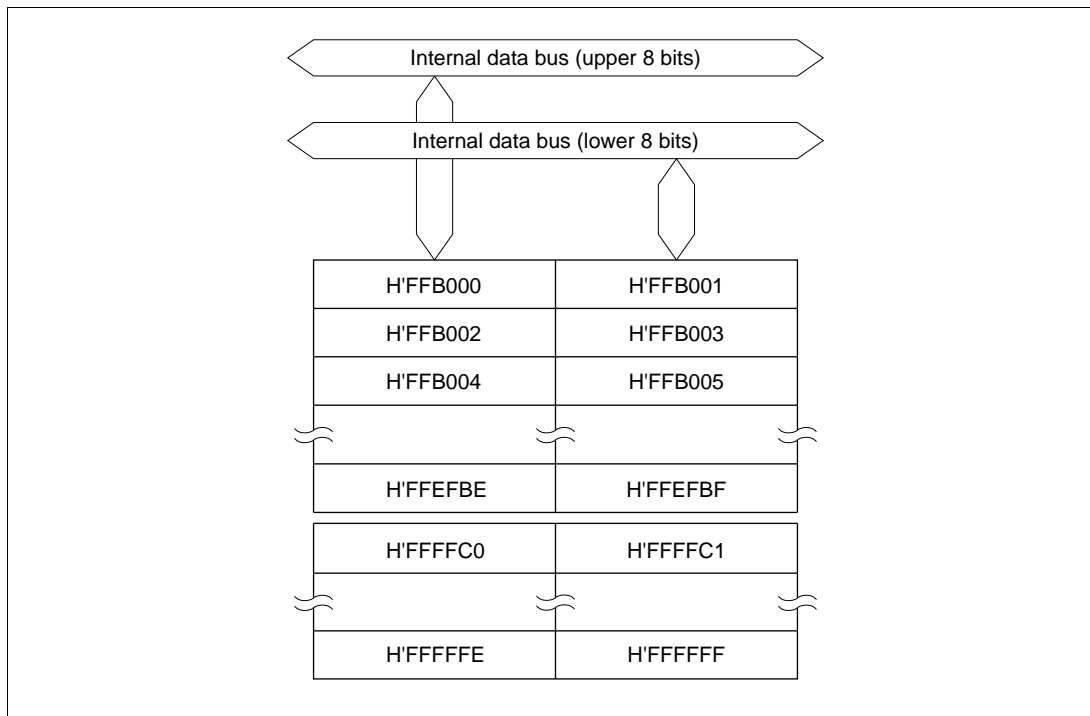


Figure 21-1 Block Diagram of RAM (H8S/2633 Series and H8S/2633R)

### 21.1.2 Register Configuration

The on-chip RAM is controlled by SYSCR. Table 21-1 shows the address and initial value of SYSCR.

**Table 21-1 RAM Register**

Name	Abbreviation	R/W	Initial Value	Address*
System control register	SYSCR	R/W	H'01	H'FDE5

Note: \* Lower 16 bits of the address.

## 21.2 Register Descriptions

### 21.2.1 System Control Register (SYSCR)

Bit	:	7	6	5	4	3	2	1	0
		MACS	—	INTM1	INTM0	NMIEG	MRESE	—	RAME
Initial value	:	0	0	0	0	0	0	0	1
R/W	:	R/W	—	R/W	R/W	R/W	R/W	—	R/W

The on-chip RAM is enabled or disabled by the RAME bit in SYSCR. For details of other bits in SYSCR, see section 3.2.2, System Control Register (SYSCR).

**Bit 0—RAM Enable (RAME):** Enables or disables the on-chip RAM. The RAME bit is initialized when the reset state is released. It is not initialized in software standby mode.

Note: When the DTC\* is used, the RAME bit must not be cleared to 0.

\* The DTC function is not available in the H8S/2695.

#### Bit 0

RAME	Description
0	On-chip RAM is disabled
1	On-chip RAM is enabled (Initial value)

### 21.3 Operation

When the RAME bit is set to 1, accesses to addresses H'FFB000 to H'FFEFBF and H'FFFFC0 to H'FFFFFF in the H8S/2633 and H8S/2633R, to addresses H'FFC000 to H'FFEFBF and H'FFFFC0 to H'FFFFFF in the H8S/2632, and to addresses H'FFD000 to H'FFEFBF and H'FFFFC0 to H'FFFFFF in the H8S/2631 and H8S/2695, are directed to the on-chip RAM. When the RAME bit is cleared to 0, the off-chip address space is accessed.

Since the on-chip RAM is connected to the CPU by an internal 16-bit data bus, it can be written to and read in byte or word units. Each type of access can be performed in one state.

Even addresses use the upper 8 bits, and odd addresses use the lower 8 bits. Word data must start at an even address.

### 21.4 Usage Notes

**When Using the DTC\*:** DTC\* register information can be located in addresses H'FFEBC0 to H'FFEFBF. When the DTC\* is used, the RAME bit must not be cleared to 0.

Note: \* The DTC function is not available in the H8S/2695.

**Reserved Areas:** Addresses H'FFB000 to H'FFBFFF in the H8S/2632, and H'FFB000 to H'FFCFFF in the H8S/2631 and H8S/2695 are reserved areas that cannot be read or written to. When the RAME bit is cleared to 0, the off-chip address space is accessed.



## Section 22 ROM

### 22.1 Overview

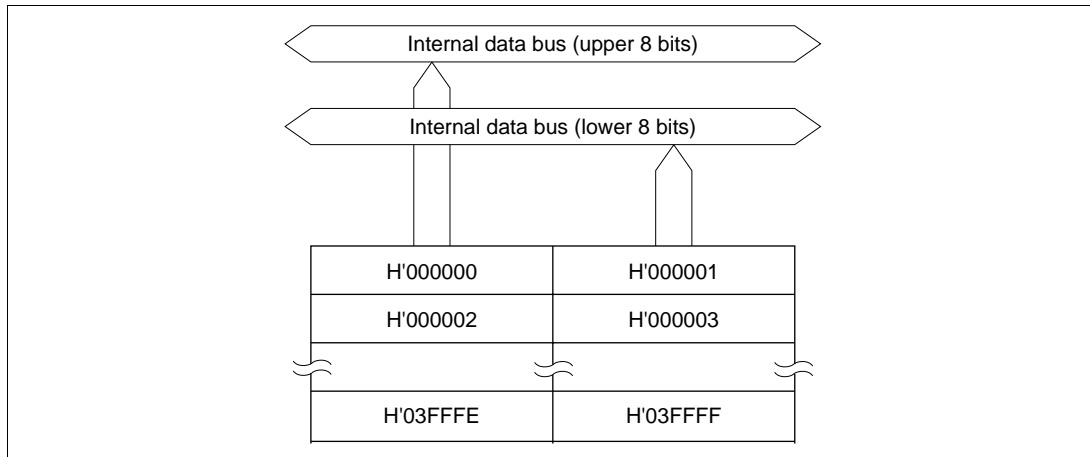
The H8/2633 Series has 256 kbytes of on-chip flash memory, or 256, 192, or 128 kbytes of on-chip mask ROM, the H8S/2633 and H8S/2633R have 256 kbytes of flash memory, and the H8S/2695 has 192 kbytes of mask ROM. The ROM is connected to the bus master via a 16-bit data bus, enabling both byte and word data to be accessed in one state. Instruction fetching is thus speeded up, and processing speed increased.

The on-chip ROM is enabled and disabled by setting the mode pins (MD2, MD1, and MD0).

The flash memory version can be erased and programmed on-board, as well as with a special-purpose PROM programmer.

#### 22.1.1 Block Diagram

Figure 22-1 shows a block diagram of 256-kbyte ROM.



**Figure 22-1 Block Diagram of ROM (256 kbytes)**

#### 22.1.2 Register Configuration

The H8/2633 Series operating mode is controlled by the mode pins and the MDCR register. The register configuration is shown in table 22-1.

**Table 22-1 Register Configuration**

Register Name	Abbreviation	R/W	Initial Value	Address*
Mode control register	MDCR	R/W	Undefined	H'FDE7

Note: \* Lower 16 bits of the address.

## 22.2 Register Descriptions

### 22.2.1 Mode Control Register (MDCR)

Bit:	7	6	5	4	3	2	1	0
	—	—	—	—	—	MDS2	MDS1	MDS0
Initial value:	1	0	0	0	0	—*	—*	—*
R/W:	R/W	—	—	—	—	R	R	R

Note: \* Determined by pins MD2 to MD0.

MDCR is an 8-bit read-only register used to monitor the current H8/2633 Series operating mode.

**Bit 7—Reserved:** Only 1 should be written to this bit.

**Bits 6 to 3—Reserved:** Read-only bits, always read as 0.

**Bits 2 to 0—Mode Select 2 to 0 (MDS2 to MDS0):** These bits indicate the input levels at pins MD2 to MD0 (the current operating mode). Bits MDS2 to MDS0 correspond to pins MD2 to MD0. MDS2 to MDS0 are read-only bits, and cannot be modified. The mode pin (MD2 to MD0) input levels are latched into these bits when MDCR is read. These latches are canceled by a power-on reset, but are retained in a manual reset.

## 22.3 Operation

The on-chip ROM is connected to the CPU by a 16-bit data bus, and both byte and word data can be accessed in one state. Even addresses are connected to the upper 8 bits, and odd addresses to the lower 8 bits. Word data must start at an even address.

The on-chip ROM is enabled and disabled by setting the mode pins (MD2, MD1, and MD0). These settings are shown in table 22-2.

**Table 22-2 Operating Modes and ROM (F-ZTAT Version)**

Operating Mode	Mode Pins				On-Chip ROM
	FWE	MD2	MD1	MD0	
Mode 0	—	0	0	0	—
Mode 1				1	
Mode 2			1	0	
Mode 3				1	
Mode 4	Advanced expanded mode with on-chip ROM disabled	1	0	0	Disabled
Mode 5	Advanced expanded mode with on-chip ROM disabled			1	
Mode 6	Advanced expanded mode with on-chip ROM enabled		1	0	Enabled (256 kbytes)
Mode 7	Advanced single-chip mode			1	Enabled (256 kbytes)
Mode 8	—	1	0	0	—
Mode 9				1	
Mode 10	Boot mode (advanced expanded mode with on-chip ROM enabled)* <sup>1</sup>		1	0	Enabled (256 kbytes)
Mode 11	Boot mode (advanced single-chip mode)* <sup>2</sup>			1	Enabled (256 kbytes)
Mode 12	—	1	0	0	—
Mode 13				1	
Mode 14	User program mode (advanced expanded mode with on-chip ROM enabled)* <sup>1</sup>		1	0	Enabled (256 kbytes)
Mode 15	User program mode (advanced single-chip mode)* <sup>2</sup>			1	Enabled (256 kbytes)

Notes: \*1 Apart from the fact that flash memory can be erased and programmed, operation is the same as in advanced expanded mode with on-chip ROM enabled.

\*2 Apart from the fact that flash memory can be erased and programmed, operation is the same as in advanced single-chip mode.

**Table 22-3 Operating Modes and ROM (Mask ROM Version)**

Operating Mode		Mode Pins			On-Chip ROM
		MD2	MD1	MD0	
Mode 0	—	0	0	0	—
Mode 1				1	
Mode 2			1	0	
Mode 3				1	
Mode 4	Advanced expanded mode with on-chip ROM disabled	1	0	0	Disabled
Mode 5	Advanced expanded mode with on-chip ROM disabled			1	
Mode 6	Advanced expanded mode with on-chip ROM enabled		1	0	Enabled (256 kbytes)*
Mode 7	Advanced single-chip mode			1	Enabled (256 kbytes)*

Note: \* In the case of the H8S/2633. 192 kbytes are enabled in the H8S/2632 and H8S/2695, and 128 kbytes in the H8S/2631.



## 22.4 Flash Memory Overview

### 22.4.1 Features

The H8S/2633 Series has 256 kbytes of on-chip flash memory. The features of the flash memory are summarized below.

- Four flash memory operating modes
  - Program mode
  - Erase mode
  - Program-verify mode
  - Erase-verify mode
- Programming/erase methods

The flash memory is programmed 128 bytes at a time. Block erase (in single-block units) can be performed. To erase the entire flash memory, each block must be erased in turn. Block erasing can be performed as required on 4 kbytes, 32 kbytes, and 64 kbytes blocks.
- Programming/erase times

The flash memory programming time is 10 ms (typ.) for simultaneous 128-byte programming, equivalent to 78  $\mu$ s (typ.) per byte, and the erase time is 100 ms (typ.).
- Reprogramming capability

The flash memory can be reprogrammed up to 100 times.
- On-board programming modes

There are two modes in which flash memory can be programmed/erased/verified on-board:

  - Boot mode
  - User program mode
- Automatic bit rate adjustment

With data transfer in boot mode, the LSI's bit rate can be automatically adjusted to match the transfer bit rate of the host.
- Flash memory emulation in RAM

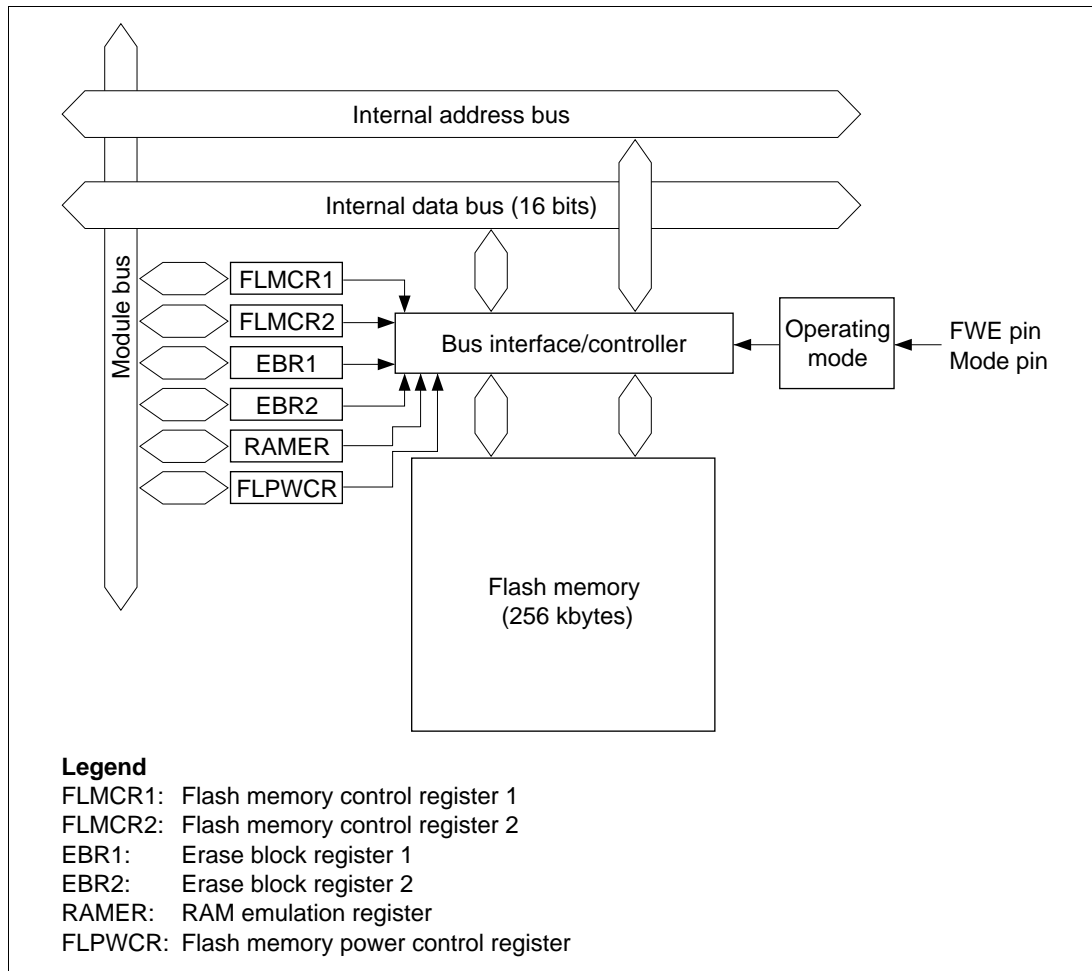
Flash memory programming can be emulated in real time by overlapping a part of RAM onto flash memory.
- Protect modes

There are three protect modes, hardware, software, and error protection, which allow protected status to be designated for flash memory program/erase/verify operations.
- Programmer mode

Flash memory can be programmed/erased in programmer mode, using a PROM programmer, as well as in on-board programming mode.

## 22.4.2 Overview

### Block Diagram



**Figure 22-2 Block Diagram of Flash Memory**

### 22.4.3 Flash Memory Operating Modes

#### Mode Transitions

When the mode pins and the FWE pin are set in the reset state and a reset-start is executed, the microcomputer enters an operating mode as shown in figure 22-3. In user mode, flash memory can be read but not programmed or erased.

The boot, user program and programmer modes are provided as modes to write and erase the flash memory.

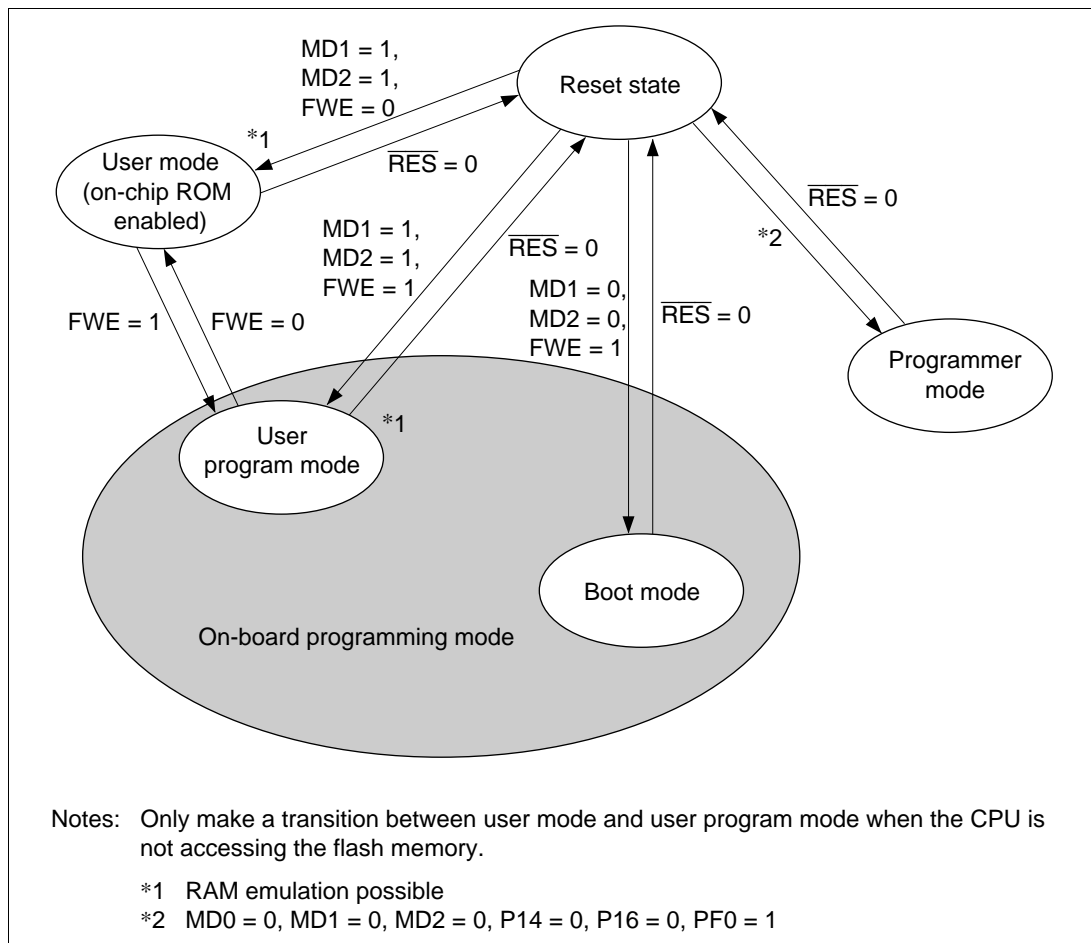


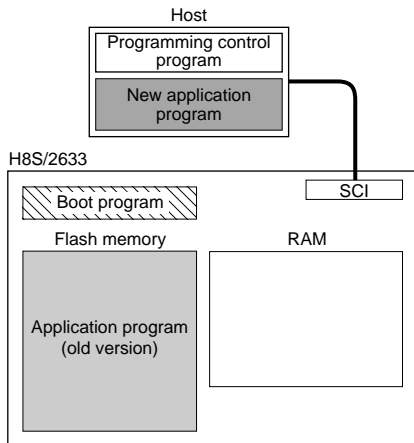
Figure 22-3 Flash Memory State Transitions

## 22.4.4 On-Board Programming Modes

### Boot Mode

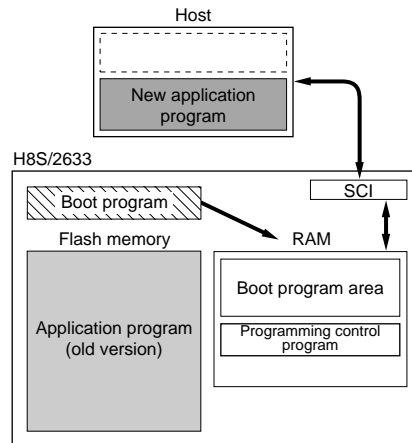
#### 1. Initial state

The old program version or data remains written in the flash memory. The user should prepare the programming control program and new application program beforehand in the host.



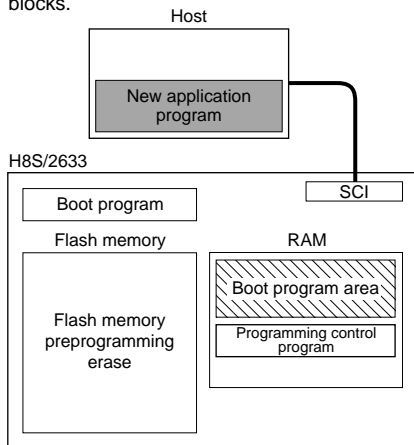
#### 2. Programming control program transfer

When boot mode is entered, the boot program in the H8S/2633 (originally incorporated in the chip) is started and the programming control program in the host is transferred to RAM via SCI communication. The boot program required for flash memory erasing is automatically transferred to the RAM boot program area.



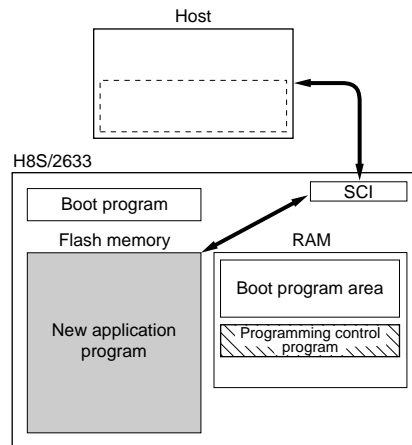
#### 3. Flash memory initialization


The erase program in the boot program area (in RAM) is executed, and the flash memory is initialized (to H'FF). In boot mode, total flash memory erasure is performed, without regard to blocks.



#### 4. Writing new application program

The programming control program transferred from the host to RAM is executed, and the new application program in the host is written into the flash memory.

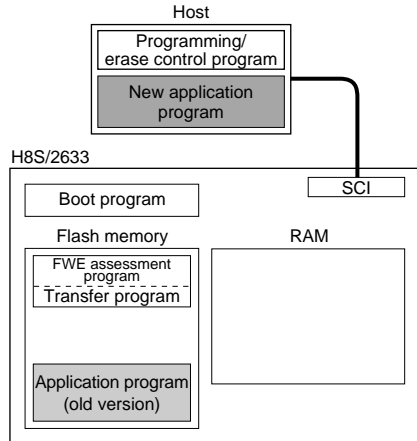


 Program execution state

## User Program Mode

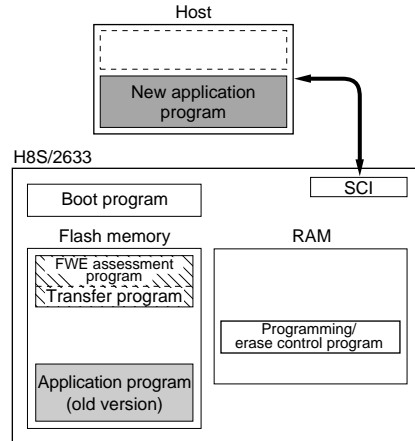
### 1. Initial state

The FWE assessment program that confirms that user program mode has been entered, and the program that will transfer the programming/erase control program from flash memory to on-chip RAM should be written into the flash memory by the user beforehand. The programming/erase control program should be prepared in the host or in the flash memory.



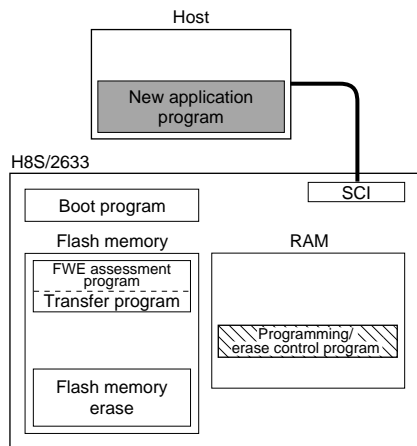
### 2. Programming/erase control program transfer

When user program mode is entered, user software confirms this fact, executes transfer program in the flash memory, and transfers the programming/erase control program to RAM.



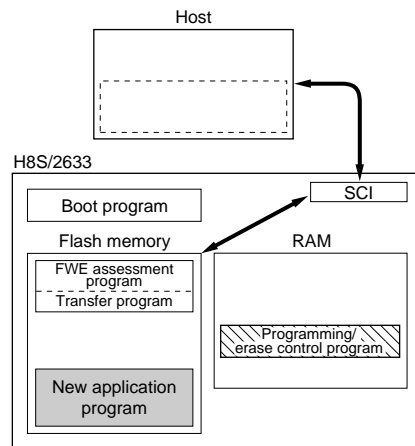
### 3. Flash memory initialization


The programming/erase program in RAM is executed, and the flash memory is initialized (to H'FF). Erasing can be performed in block units, but not in byte units.



### 4. Writing new application program

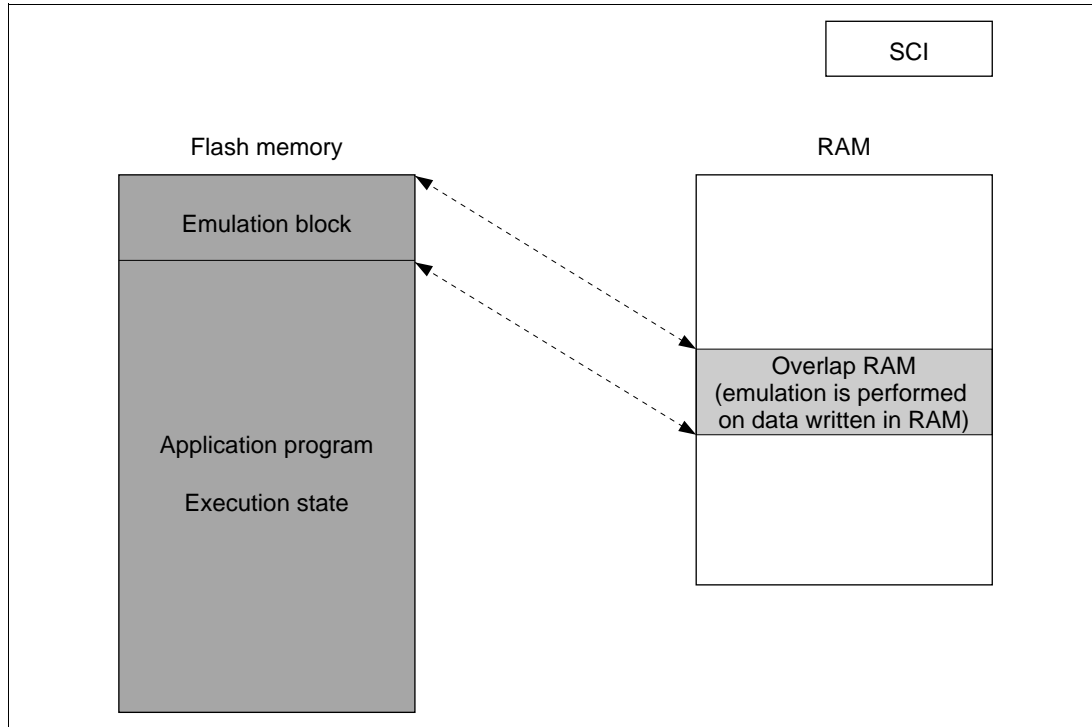
Next, the new application program in the host is written into the erased flash memory blocks. Do not write to unerased blocks.



 Program execution state

### 22.4.5 Flash Memory Emulation in RAM

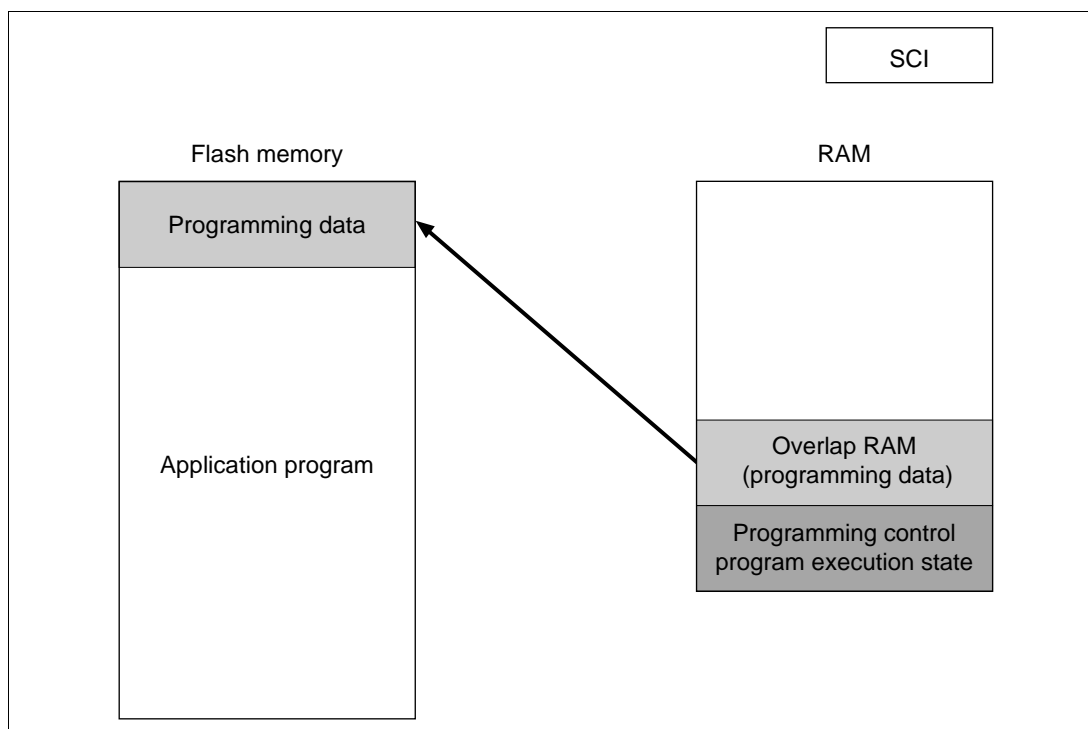
Emulation should be performed in user mode or user program mode. When the emulation block set in RAMER is accessed while the emulation function is being executed, data written in the overlap RAM is read.



**Figure 22-4 Reading Overlap RAM Data in User Mode or User Program Mode**

When overlap RAM data is confirmed, the RAMS bit is cleared, RAM overlap is released, and writes should actually be performed to the flash memory.

When the programming control program is transferred to RAM, ensure that the transfer destination and the overlap RAM do not overlap, as this will cause data in the overlap RAM to be rewritten.



**Figure 22-5 Writing Overlap RAM Data in User Program Mode**

#### 22.4.6 Differences between Boot Mode and User Program Mode

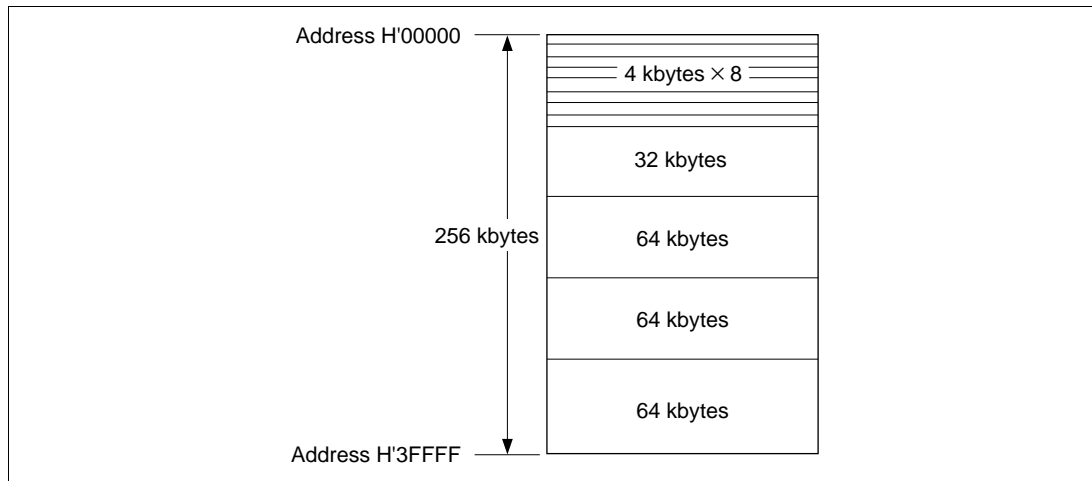
**Table 22-4 Differences between Boot Mode and User Program Mode**

	<b>Boot Mode</b>	<b>User Program Mode</b>
Total erase	Yes	Yes
Block erase	No	Yes
Programming control program*	Program/program-verify	Erase/erase-verify Program/program-verify Emulation

Note: \* To be provided by the user, in accordance with the recommended algorithm.

### 22.4.7 Block Configuration

The flash memory is divided into three 64 kbytes blocks, one 32 kbytes block, and eight 4 kbytes blocks.



**Figure 22-6 Flash Memory Block Configuration**

### 22.4.8 Pin Configuration

The flash memory is controlled by means of the pins shown in table 22-5.

**Table 22-5 Pin Configuration**

Pin Name	Abbreviation	I/O	Function
Reset	$\overline{\text{RES}}$	Input	Reset
Flash write enable	FWE	Input	Flash memory program/erase protection by hardware
Mode 2	MD2	Input	Sets MCU operating mode
Mode 1	MD1	Input	Sets MCU operating mode
Mode 0	MD0	Input	Sets MCU operating mode
Port F0	PF0	Input	Sets MCU operating mode in programmer mode
Port 16	P16	Input	Sets MCU operating mode in programmer mode
Port 14	P14	Input	Sets MCU operating mode in programmer mode
Transmit data	TxD2	Output	Serial transmit data output
Receive data	RxD2	Input	Serial receive data input



## 22.4.9 Register Configuration

The registers used to control the on-chip flash memory when enabled are shown in table 22-6. In order to access these registers, the FLSHE bit in SCRX must be set to 1 (except for RAMER and SCRX).

**Table 22-6 Register Configuration**

Register Name	Abbreviation	R/W	Initial Value	Address* <sup>1</sup>
Flash memory control register 1	FLMCR1* <sup>5</sup>	R/W* <sup>2</sup>	H'00* <sup>3</sup>	H'FFA8
Flash memory control register 2	FLMCR2* <sup>5</sup>	R* <sup>2</sup>	H'00	H'FFA9
Erase block register 1	EBR1* <sup>5</sup>	R/W* <sup>2</sup>	H'00* <sup>4</sup>	H'FFAA
Erase block register 2	EBR2* <sup>5</sup>	R/W* <sup>2</sup>	H'00* <sup>4</sup>	H'FFAB
RAM emulation register	RAMER* <sup>5</sup>	R/W	H'00	H'FEDB
Flash memory power control register	FLPWCR* <sup>5</sup>	R/W* <sup>2</sup>	H'00* <sup>4</sup>	H'FFAC
Serial control register X	SCRX	R/W	H'00	H'FDB4

Notes: \*1 Lower 16 bits of the address.

\*2 To access these registers, set the FLSHE bit to 1 in serial control register X. Even if FLSHE is set to 1, if the chip is in a mode in which the on-chip flash memory is disabled, a read will return H'00 and writes are invalid. Writes are also invalid when the FWE bit in FLMCR1 is not set to 1.

\*3 When a high level is input to the FWE pin, the initial value is H'80.

\*4 When a low level is input to the FWE pin, or if a high level is input and the SWE1 bit in FLMCR1 is not set, these registers are initialized to H'00.

\*5 FLMCR1, FLMCR2, EBR1, EBR2, RAMER, and FLPWCR are 8-bit registers. Use byte access on these registers.

## 22.5 Register Descriptions

### 22.5.1 Flash Memory Control Register 1 (FLMCR1)

Bit:	7	6	5	4	3	2	1	0
	FWE	SWE1	ESU1	PSU1	EV1	PV1	E1	P1
Initial value:	—*	0	0	0	0	0	0	0
R/W:	R	R/W	R/W	R/W	R/W	R/W	R/W	R/W

Note: \* Determined by the state of the FWE pin.

FLMCR1 is an 8-bit register used for flash memory operating mode control. Program-verify mode or erase-verify mode for addresses H'00000 to H'3FFFF is entered by setting SWE1 bit to 1 when FWE = 1, then setting the PV1 or EV1 bit. Program mode for addresses H'00000 to H'3FFFF is entered by setting SWE1 bit to 1 when FWE = 1, then setting the PSU1 bit, and finally setting the

P1 bit. Erase mode for addresses H'00000 to H'3FFFF is entered by setting SWE1 bit to 1 when FWE = 1, then setting the ESU1 bit, and finally setting the E1 bit. FLMCR1 is initialized by a power-on reset, and in hardware standby mode and software standby mode. Its initial value is H'80 when a high level is input to the FWE pin, and H'00 when a low level is input. When on-chip flash memory is disabled, a read will return H'00, and writes are invalid.

Writes are enabled only in the following cases: Writes to bit SWE1 of FLMCR1 enabled when FWE = 1, to bits ESU1, PSU1, EV1, and PV1 when FWE = 1 and SWE1 = 1, to bit E1 when FWE = 1, SWE1 = 1 and ESU1 = 1, and to bit P1 when FWE = 1, SWE1 = 1, and PSU1 = 1.

**Bit 7—Flash Write Enable Bit (FWE):** Sets hardware protection against flash memory programming/erasing.

**Bit 7**

<b>FWE</b>	<b>Description</b>
0	When a low level is input to the FWE pin (hardware-protected state)
1	When a high level is input to the FWE pin

**Bit 6—Software Write Enable Bit 1 (SWE1):** This bit selects write and erase valid/invalid of the flash memory. Set it when setting bits 5 to 0, bits 7 to 0 of EBR1, and bits 3 to 0 of EBR2.

**Bit 6**

<b>SWE1</b>	<b>Description</b>
0	Writes disabled (Initial value)
1	Writes enabled [Setting condition] When FWE = 1

**Bit 5—Erase Setup Bit 1 (ESU1):** Prepares for a transition to erase mode. Set this bit to 1 before setting the E1 bit in FLMCR1 to 1. Do not set the SWE1, PSU1, EV1, PV1, E1, or P1 bit at the same time.

**Bit 5**

<b>ESU1</b>	<b>Description</b>
0	Erase setup cleared (Initial value)
1	Erase setup [Setting condition] When FWE = 1 and SWE1 = 1

**Bit 4—Program Setup Bit 1 (PSU1):** Prepares for a transition to program mode. Set this bit to 1 before setting the P1 bit in FLMCR1 to 1. Do not set the SWE1, ESU1, EV1, PV1, E1, or P1 bit at the same time.

**Bit 4**

PSU1	Description
0	Program setup cleared (Initial value)
1	Program setup [Setting condition] When FWE = 1 and SWE1 = 1

**Bit 3—Erase-Verify 1 (EV1):** Selects erase-verify mode transition or clearing. Do not set the SWE1, ESU1, PSU1, PV1, E1, or P1 bit at the same time.

**Bit 3**

EV1	Description
0	Erase-verify mode cleared (Initial value)
1	Transition to erase-verify mode [Setting condition] When FWE = 1 and SWE1 = 1

**Bit 2—Program-Verify 1 (PV1):** Selects program-verify mode transition or clearing. Do not set the SWE1, ESU1, PSU1, EV1, E1, or P1 bit at the same time.

**Bit 2**

PV1	Description
0	Program-verify mode cleared (Initial value)
1	Transition to program-verify mode [Setting condition] When FWE = 1 and SWE1 = 1

**Bit 1—Erase 1 (E1):** Selects erase mode transition or clearing. Do not set the SWE1, ESU1, PSU1, EV1, PV1, or P1 bit at the same time.

**Bit 1**

<b>E1</b>	<b>Description</b>
0	Erase mode cleared (Initial value)
1	Transition to erase mode [Setting condition] When FWE = 1, SWE1 = 1, and ESU1 = 1

**Bit 0—Program 1 (P1):** Selects program mode transition or clearing. Do not set the SWE1, PSU1, ESU1, EV1, PV1, or E1 bit at the same time.

**Bit 0**

<b>P1</b>	<b>Description</b>
0	Program mode cleared (Initial value)
1	Transition to program mode [Setting condition] When FWE = 1, SWE1 = 1, and PSU1 = 1

**22.5.2 Flash Memory Control Register 2 (FLMCR2)**

Bit:	7	6	5	4	3	2	1	0
	FLER	—	—	—	—	—	—	—
Initial value:	0	0	0	0	0	0	0	0
R/W:	R	—	—	—	—	—	—	—

Note: FLMCR2 is a read-only register, and should not be written to.

FLMCR2 is an 8-bit register used for flash memory operating mode control. FLMCR2 is initialized to H'00 by a power-on reset, and in hardware standby mode and software standby mode. When on-chip flash memory is disabled, a read will return H'00.

**Bit 7—Flash Memory Error (FLER):** Indicates that an error has occurred during an operation on flash memory (programming or erasing). When FLER is set to 1, flash memory goes to the error-protection state.

**Bit 7**

FLER	Description
0	Flash memory is operating normally (Initial value) Flash memory program/erase protection (error protection) is disabled [Clearing condition] Power-on reset or hardware standby mode
1	An error has occurred during flash memory programming/erasing Flash memory program/erase protection (error protection) is enabled [Setting condition] See section 22.8.3, Error Protection

**Bits 6 to 0—Reserved:** These bits always read 0.

**22.5.3 Erase Block Register 1 (EBR1)**

Bit:	7	6	5	4	3	2	1	0
	EB7	EB6	EB5	EB4	EB3	EB2	EB1	EB0
Initial value:	0	0	0	0	0	0	0	0
R/W:	R/W	R/W	R/W	R/W	R/W	R/W	R/W	R/W

EBR1 is an 8-bit register that specifies the flash memory erase area block by block. EBR1 is initialized to H'00 by a power-on reset, in hardware standby mode and software standby mode, when a low level is input to the FWE pin, and when a high level is input to the FWE pin and the SWE1 bit in FLMCR1 is not set. When a bit in EBR1 is set to 1, the corresponding block can be erased. Other blocks are erase-protected. Only one of the bits of EBR1 and EBR2 combined can be set. Do not set more than one bit, as this will cause all the bits in both EBR1 and EBR2 to be automatically cleared to 0. When on-chip flash memory is disabled, a read will return H'00, and writes are invalid.

The flash memory erase block configuration is shown in table 22-7.

#### 22.5.4 Erase Block Register 2 (EBR2)

Bit:	7	6	5	4	3	2	1	0
	—	—	—	—	EB11	EB10	EB9	EB8
Initial value:	0	0	0	0	0	0	0	0
R/W:	R/W	R/W	R/W	R/W	R/W	R/W	R/W	R/W

EBR2 is an 8-bit register that specifies the flash memory erase area block by block. EBR2 is initialized to H'00 by a power-on reset, in hardware standby mode and software standby mode, when a low level is input to the FWE pin. Bit 0 will be initialized to 0 if bit SWE1 of FLMCR1 is not set, even though a high level is input to pin FWE. When a bit in EBR2 is set to 1, the corresponding block can be erased. Other blocks are erase-protected. Only one of the bits of EBR1 and EBR2 combined can be set. Do not set more than one bit, as this will cause all the bits in both EBR1 and EBR2 to be automatically cleared to 0. Bits 7 to 4 are reserved and must only be written with 0. When on-chip flash memory is disabled, a read will return H'00, and writes are invalid.

The flash memory erase block configuration is shown in table 22-7.

**Table 22-7 Flash Memory Erase Blocks**

Block (Size)	Addresses
EB0 (4 kbytes)	H'000000–H'000FFF
EB1 (4 kbytes)	H'001000–H'001FFF
EB2 (4 kbytes)	H'002000–H'002FFF
EB3 (4 kbytes)	H'003000–H'003FFF
EB4 (4 kbytes)	H'004000–H'004FFF
EB5 (4 kbytes)	H'005000–H'005FFF
EB6 (4 kbytes)	H'006000–H'006FFF
EB7 (4 kbytes)	H'007000–H'007FFF
EB8 (32 kbytes)	H'008000–H'00FFFF
EB9 (64 kbytes)	H'010000–H'01FFFF
EB10 (64 kbytes)	H'020000–H'02FFFF
EB11 (64 kbytes)	H'030000–H'03FFFF

### 22.5.5 RAM Emulation Register (RAMER)

Bit:	7	6	5	4	3	2	1	0
	—	—	—	—	RAMS	RAM2	RAM1	RAM0
Initial value:	0	0	0	0	0	0	0	0
R/W:	R	R	R/W	R/W	R/W	R/W	R/W	R/W

RAMER specifies the area of flash memory to be overlapped with part of RAM when emulating real-time flash memory programming. RAMER initialized to H'00 by a power-on reset and in hardware standby mode. It is not initialized by a manual reset and in software standby mode. RAMER settings should be made in user mode or user program mode.

Flash memory area divisions are shown in table 22-8. To ensure correct operation of the emulation function, the ROM for which RAM emulation is performed should not be accessed immediately after this register has been modified. Normal execution of an access immediately after register modification is not guaranteed.

**Bits 7 and 6—Reserved:** These bits always read 0.

**Bits 5 and 4—Reserved:** Only 0 may be written to these bits.

**Bit 3—RAM Select (RAMS):** Specifies selection or non-selection of flash memory emulation in RAM. When RAMS = 1, all flash memory block are program/erase-protected.

#### Bit 3

RAMS	Description
0	Emulation not selected (Initial value) Program/erase-protection of all flash memory blocks is disabled
1	Emulation selected Program/erase-protection of all flash memory blocks is enabled

**Bits 2 to 0—Flash Memory Area Selection:** These bits are used together with bit 3 to select the flash memory area to be overlapped with RAM. (See table 22-8.)

**Table 22-8 Flash Memory Area Divisions**

Addresses	Block Name	RAMS	RAM1	RAM1	RAM0
H'FFD000–H'FFDFFF	RAM area 4 kbytes	0	*	*	*
H'000000–H'000FFF	EB0 (4 kbytes)	1	0	0	0
H'001000–H'001FFF	EB1 (4 kbytes)	1	0	0	1
H'002000–H'002FFF	EB2 (4 kbytes)	1	0	1	0
H'003000–H'003FFF	EB3 (4 kbytes)	1	0	1	1
H'004000–H'004FFF	EB4 (4 kbytes)	1	1	0	0
H'005000–H'005FFF	EB5 (4 kbytes)	1	1	0	1
H'006000–H'006FFF	EB6 (4 kbytes)	1	1	1	0
H'007000–H'007FFF	EB7 (4 kbytes)	1	1	1	1

\*: Don't care



### 22.5.6 Flash Memory Power Control Register (FLPWCR)

Bit:	7	6	5	4	3	2	1	0
	PDWND	—	—	—	—	—	—	—
Initial value:	0	0	0	0	0	0	0	0
R/W:	R/W	R	R	R	R	R	R	R

FLPWCR enables or disables a transition to the flash memory power-down mode when the LSI switches to subactive mode.

**Bit 7—Power-Down Disable (PDWND):** Enables or disables a transition to the flash memory power-down mode when the LSI switches to subactive mode.

#### Bit 7

PDWND	Description
0	Transition to flash memory power-down mode enabled (Initial value)
1	Transition to flash memory power-down mode disabled

**Bits 6 to 0—Reserved:** These bits always read 0.

### 22.5.7 Serial Control Register X (SCRX)

Bit:	7	6	5	4	3	2	1	0
	—	IICX1	IICX0	IICE	FLSHE	—	—	—
Initial value:	0	0	0	0	0	0	0	0
R/W:	R/W	R/W	R/W	R/W	R/W	R/W	R/W	R/W

SCRX is an 8-bit readable/writable register that controls on-chip flash memory.

SCRX is initialized to H'00 by a reset and in hardware standby mode.

**Bit 7—Reserved:** This bit should always be written with 0.

**Bits 6 and 5—I<sup>2</sup>C Transfer Rate Select (IICX1 and IICX0):** These bits, together with bits CKS2 to CKS0 in ICMR, select the transfer rate in master mode. For details of the transfer rate, see section 18.2.4, I<sup>2</sup>C Bus Mode Register (ICMR).

**Bit 4—I<sup>2</sup>C Master Enable (IICE):** Controls access to the I<sup>2</sup>C bus interface data registers and control registers (ICCR, ICSR, ICDR/SARX, and ICMR/SAR). For details of the control, see section 18.2.7, Serial Control Register X (SCRX).

**Bit 3—Flash Memory Control Register Enable (FLSHE):** Controls CPU access to the flash memory control registers (FLMCR1, FLMCR2, EBR1, and EBR2). Setting the FLSHE bit to 1 enables read/write access to the flash memory control registers. If FLSHE is cleared to 0, the flash memory control registers are deselected. In this case, the flash memory control register contents are retained.

**Bit 3**

FLSHE	Description
0	Flash control registers deselected in area H'FFFA8 to H'FFFAC (Initial value)
1	Flash control registers selected in area H'FFFA8 to H'FFFAC

**Bits 2 to 0—Reserved:** Should always be written with 0.

## 22.6 On-Board Programming Modes

When pins are set to on-board programming mode and a reset-start is executed, a transition is made to the on-board programming state in which program/erase/verify operations can be performed on the on-chip flash memory. There are two on-board programming modes: boot mode and user program mode. The pin settings for transition to each of these modes are shown in table 22-9. For a diagram of the transitions to the various flash memory modes, see figure 22-11.

**Table 22-9 Setting On-Board Programming Modes**

Mode		FWE	MD2	MD1	MD0
Boot mode	Expanded mode	1	0	1	0
	Single-chip mode		0	1	1
User program mode	Expanded mode	1	1	1	0
	Single-chip mode		1	1	1

### 22.6.1 Boot Mode

When boot mode is used, the flash memory programming control program must be prepared in the host beforehand. The SCI channel to be used is set to asynchronous mode.

When a reset-start is executed after the H8S/2633 Series' pins have been set to boot mode, the boot program built into the H8S/2633 Series is started and the programming control program prepared in the host is serially transmitted to the H8S/2633 Series via the SCI. In the H8S/2633 Series, the programming control program received via the SCI is written into the programming control program area in on-chip RAM. After the transfer is completed, control branches to the start address of the programming control program area and the programming control program execution state is entered (flash memory programming is performed).

The transferred programming control program must therefore include coding that follows the programming algorithm given later.

The system configuration in boot mode is shown in figure 22-7, and the boot mode execution procedure in figure 22-8.

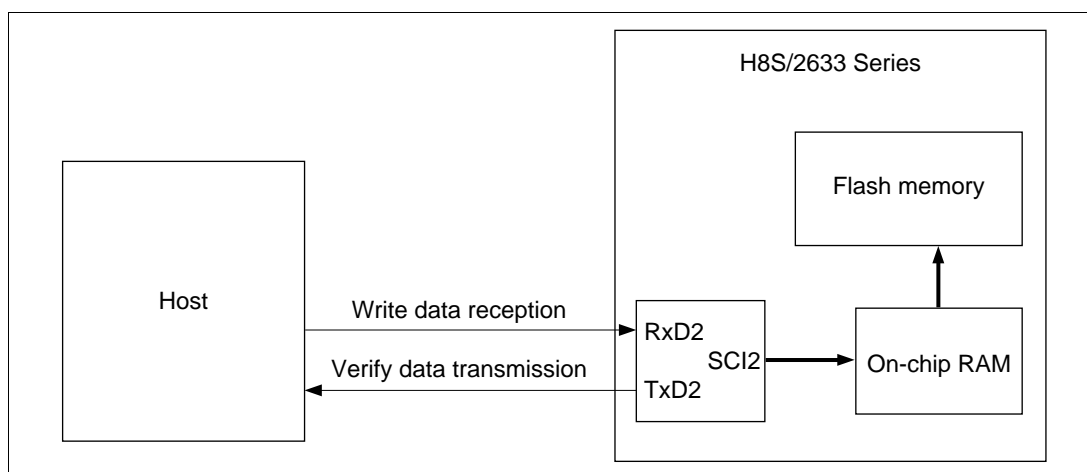
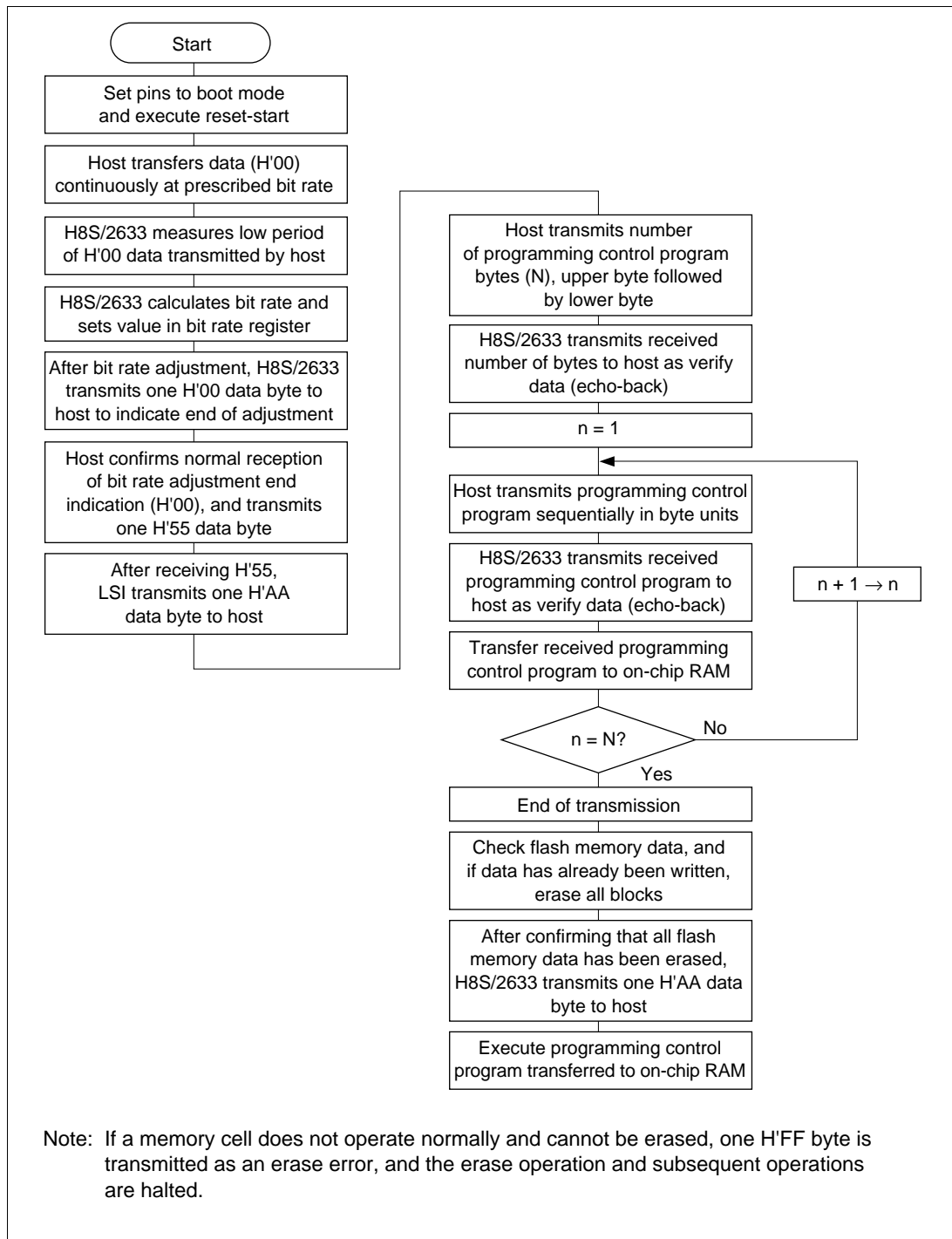
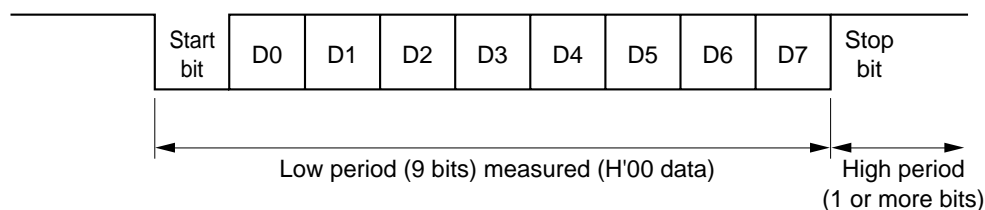


Figure 22-7 System Configuration in Boot Mode



**Figure 22-8 Boot Mode Execution Procedure**

## Automatic SCI Bit Rate Adjustment



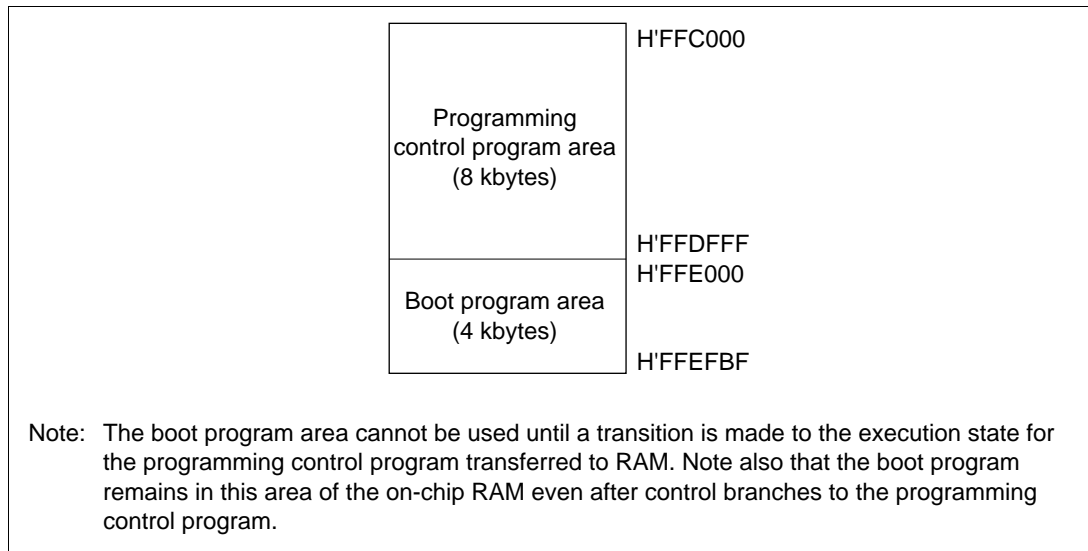
When boot mode is initiated, the H8S/2633 Series measures the low period of the asynchronous SCI communication data (H'00) transmitted continuously from the host. The SCI transmit/receive format should be set as follows: 8-bit data, 1 stop bit, no parity. The H8S/2633 Series calculates the bit rate of the transmission from the host from the measured low period, and transmits one H'00 byte to the host to indicate the end of bit rate adjustment. The host should confirm that this adjustment end indication (H'00) has been received normally, and transmit one H'55 byte to the H8S/2633 Series. If reception cannot be performed normally, initiate boot mode again (reset), and repeat the above operations. Depending on the host's transmission bit rate and the H8S/2633 Series' system clock frequency, there will be a discrepancy between the bit rates of the host and the H8S/2633 Series. Set the host transfer bit rate at 2,400, 4,800, 9,600 or 19,200 bps to operate the SCI properly.

Table 22-10 shows host transfer bit rates and system clock frequencies for which automatic adjustment of the H8S/2633 Series bit rate is possible. The boot program should be executed within this system clock range.

**Table 22-10 System Clock Frequencies for which Automatic Adjustment of H8S/2633 Series Bit Rate is Possible**

Host Bit Rate	System Clock Frequency for Which Automatic Adjustment of H8S/2633 Series Bit Rate is Possible
2,400 bps	2 to 8 MHz
4,800 bps	4 to 16 MHz
9,600 bps	8 to 25 MHz
19,200 bps	16 to 25 MHz

**On-Chip RAM Area Divisions in Boot Mode:** In boot mode, the RAM area is divided into an area used by the boot program and an area to which the programming control program is transferred via the SCI, as shown in figure 22-9. The boot program area cannot be used until the execution state in boot mode switches to the programming control program transferred from the host.



**Figure 22-9 RAM Areas in Boot Mode**

**Notes on Use of Boot Mode:**

- When the chip comes out of reset in boot mode, it measures the low-level period of the input at the SCI's RxD2 pin. The reset should end with RxD2 high. After the reset ends, it takes approximately 100 states before the chip is ready to measure the low-level period of the RxD2 pin.
- In boot mode, if any data has been programmed into the flash memory (if all data is not 1), all flash memory blocks are erased. Boot mode is for use when user program mode is unavailable, such as the first time on-board programming is performed, or if the program activated in user program mode is accidentally erased.
- Interrupts cannot be used while the flash memory is being programmed or erased.
- The RxD2 and TxD2 pins should be pulled up on the board.
- Before branching to the programming control program (RAM area H'FFC000), the chip terminates transmit and receive operations by the on-chip SCI (channel 2) (by clearing the RE and TE bits in SCR to 0), but the adjusted bit rate value remains set in BRR. The transmit data output pin, TxD2, goes to the high-level output state (PA1DDR = 1, PA1DR = 1).

The contents of the CPU's internal general registers are undefined at this time, so these registers must be initialized immediately after branching to the programming control program. In particular, since the stack pointer (SP) is used implicitly in subroutine calls, etc., a stack area must be specified for use by the programming control program.

The initial values of other on-chip registers are not changed.

- Boot mode can be entered by making the pin settings shown in table 22-9 and executing a reset-start.

Boot mode can be cleared by driving the reset pin low, waiting at least 20 states, then setting the FWE pin and mode pins, and executing reset release\*<sup>1</sup>. Boot mode can also be cleared by a WDT overflow reset.

Do not change the mode pin input levels in boot mode, and do not drive the FWE pin low while the boot program is being executed or while flash memory is being programmed or erased\*<sup>2</sup>.

- If the mode pin input levels are changed (for example, from low to high) during a reset, the state of ports with multiplexed address functions and bus control output pins (AS, RD, and HWR) will change according to the change in the microcomputer's operating mode\*<sup>3</sup>.

Therefore, care must be taken to make pin settings to prevent these pins from becoming output signal pins during a reset, or to prevent collision with signals outside the microcomputer.

Notes: \*1 Mode pin and FWE pin input must satisfy the mode programming setup time ( $t_{MDS} = 4$  states) with respect to the reset release timing.

\*2 For further information on FWE application and disconnection, see section 22.13, Flash Memory Programming and Erasing Precautions.

\*3 See Appendix D, Pin States.

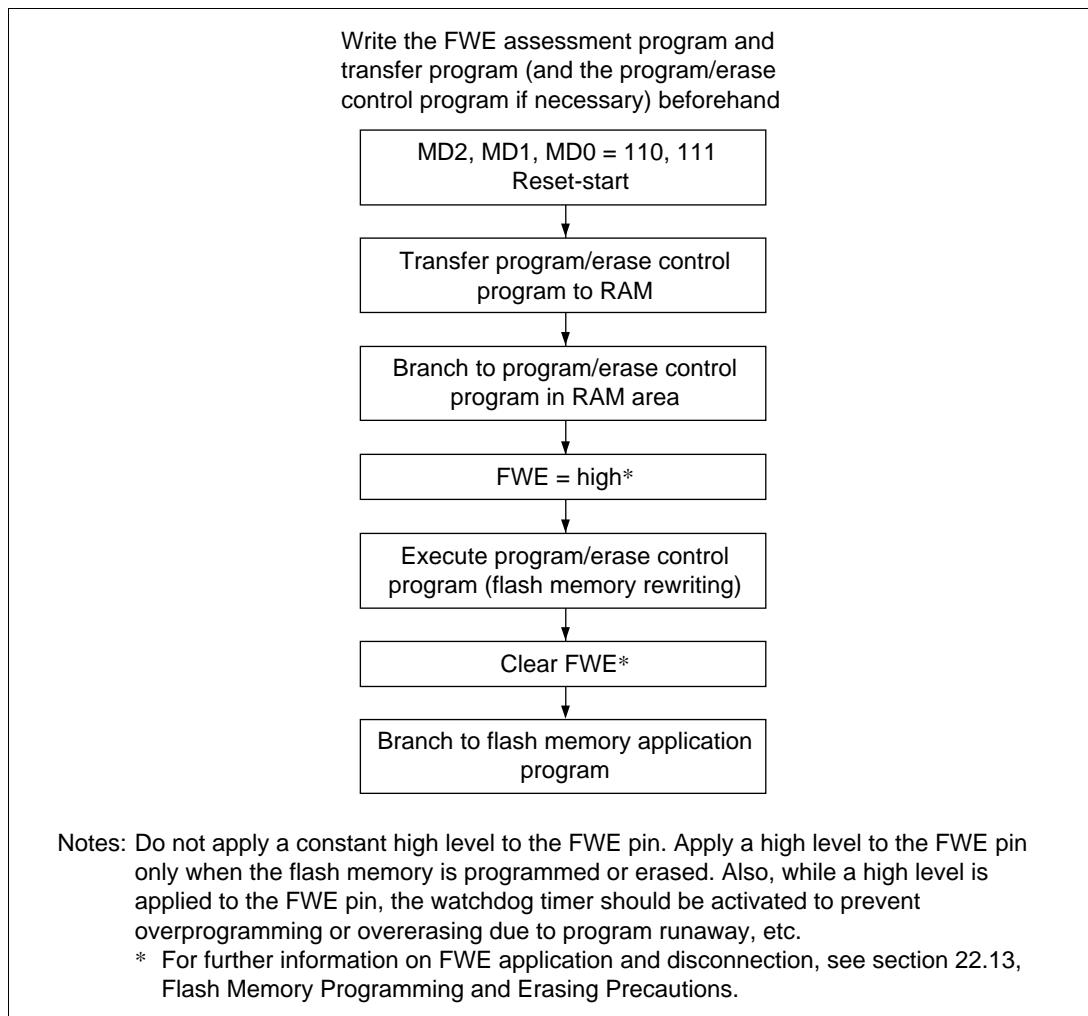
### 22.6.2 User Program Mode

When set to user program mode, the chip can program and erase its flash memory by executing a user program/erase control program. Therefore, on-board reprogramming of the on-chip flash memory can be carried out by providing on-board means of FWE control and supply of programming data, and storing a program/erase control program in part of the program area as necessary.

To select user program mode, select a mode that enables the on-chip flash memory (mode 6 or 7), and apply a high level to the FWE pin. In this mode, on-chip supporting modules other than flash memory operate as they normally would in modes 6 and 7.

The flash memory itself cannot be read while the SWE1 bit is set to 1 to perform programming or erasing, so the control program that performs programming and erasing should be run in on-chip RAM or external memory. If the program is to be located in external memory, the instruction for writing to flash memory, and the following instruction, should be placed in on-chip RAM.

Figure 22-10 shows the procedure for executing the program/erase control program when transferred to on-chip RAM.



**Figure 22-10 User Program Mode Execution Procedure**



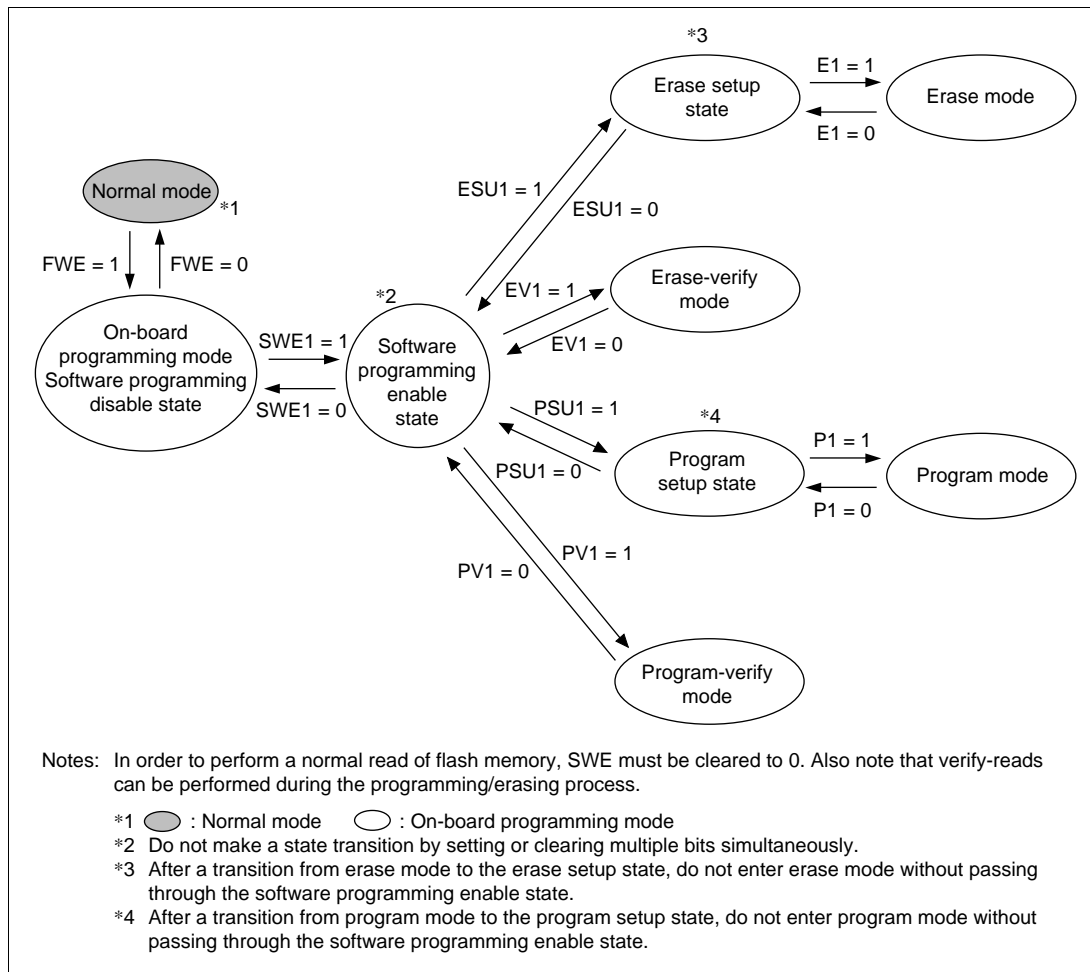
## 22.7 Programming/Erasing Flash Memory

A software method, using the CPU, is employed to program and erase flash memory in the on-board programming modes. There are four flash memory operating modes: program mode, erase mode, program-verify mode, and erase-verify mode. Transitions to these modes are made by setting the PSU1, ESU1, P1, E1, PV1, and EV1 bits in FLMCR1 for addresses H'000000 to H'03FFFF.

The flash memory cannot be read while it is being written or erased. The flash memory cannot be read while being programmed or erased. Therefore, the program (user program) that controls flash memory programming/erasing should be located and executed in on-chip RAM or external memory. If the program is to be located in external memory, the instruction for writing to flash memory, and the following instruction, should be placed in on-chip RAM. Also ensure that the DTC and DMAC is not activated before or after execution of the flash memory write instruction.

In the following operation descriptions, wait times after setting or clearing individual bits in FLMCR1 are given as parameters; for details of the wait times, see section 25.6 and 26.6, Flash Memory Characteristics.

- Notes:
1. Operation is not guaranteed if bits SWE1, ESU1, PSU1, EV1, PV1, E1, and P1 of FLMCR1 are set/reset by a program in flash memory in the corresponding address areas.
  2. When programming or erasing, set FWE to 1 (programming/erasing will not be executed if FWE = 0).
  3. Programming should be performed in the erased state. Do not perform additional programming on previously programmed addresses.



**Figure 22-11 FLMCR1 Bit Settings and State Transitions**

### 22.7.1 Program Mode

When writing data or programs to flash memory, the program/program-verify flowchart shown in figure 22-12 should be followed. Performing program operations according to this flowchart will enable data or programs to be written to flash memory without subjecting the device to voltage stress or sacrificing program data reliability. Programming should be carried out 128 bytes at a time.

The wait times after bits are set or cleared in the flash memory control register 1 (FLMCR1) and the maximum number of programming operations (N1 + N2) are shown in table 25-13 and 26-13 in section 25.6 and 26.6, Flash Memory Characteristics.

Following the elapse of  $(x0)$   $\mu\text{s}$  or more after the SWE1 bit is set to 1 in FLMCR1, 128-byte program data is stored in the program data area and reprogram data area, and the 128-byte data in the program data area in RAM is written consecutively to the program address (the lower 8 bits of the first address written to must be H'00 or H'80). 128 consecutive byte data transfers are performed. The program address and program data are latched in the flash memory. A 128-byte data transfer must be performed even if writing fewer than 128 bytes; in this case, H'FF data must be written to the extra addresses.

Next, the watchdog timer is set to prevent overprogramming in the event of program runaway, etc. Set a value greater than  $(y + z2 + \alpha + \beta)$  ms as the WDT overflow period. After this, preparation for program mode (program setup) is carried out by setting the PSU1 bit in FLMCR1, and after the elapse of  $(y)$   $\mu\text{s}$  or more, the operating mode is switched to program mode by setting the P1 bit in FLMCR1. The time during which the P1 bit is set is the flash memory programming time. Refer to the table in figure 22-12 for the programming time.

### 22.7.2 Program-Verify Mode

In program-verify mode, the data written in program mode is read to check whether it has been correctly written in the flash memory.

After the elapse of the given programming time, clear the P1 bit in FLMCR1, then wait for at least  $(\alpha)$   $\mu\text{s}$  before clearing the PSU1 bit to exit program mode. After the elapse of at least  $(\beta)$   $\mu\text{s}$ , the watchdog timer is cleared and the operating mode is switched to program-verify mode by setting the PV1 bit in FLMCR1. Before reading in program-verify mode, a dummy write of H'FF data should be made to the addresses to be read. The dummy write should be executed after the elapse of  $(\gamma)$   $\mu\text{s}$  or more. When the flash memory is read in this state (verify data is read in 16-bit units), the data at the latched address is read. Wait at least  $(\epsilon)$   $\mu\text{s}$  after the dummy write before performing this read operation. Next, the originally written data is compared with the verify data, and reprogram data is computed (see figure 22-12) and transferred to RAM. After verification of 128 bytes of data has been completed, exit program-verify mode, wait for at least  $(\eta)$   $\mu\text{s}$ , then clear the SWE1 bit in FLMCR1. If reprogramming is necessary, set program mode again, and repeat the program/program-verify sequence as before. The maximum number of repetitions of the program/program-verify sequence is indicated by the maximum programming count  $(N1 + N2)$ . However, ensure that the program/program-verify sequence is not repeated more than  $(N1 + N2)$  times on the same bits.

## Notes on Program/Program-Verify Procedure

1. In order to perform 128-byte-unit programming, the lower 8 bits of the write start address must be H'00 or H'80.
2. When performing continuous writing of 128-byte data to flash memory, byte-unit transfer should be used.  
128-byte data transfer is necessary even when writing fewer than 128 bytes of data. Write H'FF data to the extra addresses.
3. Verify data is read in word units.
4. The write pulse is applied and a flash memory write executed while the P1 bit in FLMCR1 is set. In the H8S/2633, write pulses should be applied as follows in the program/program-verify procedure to prevent voltage stress on the device and loss of write data reliability.
  - a. After write pulse application, perform a verify-read in program-verify mode and apply a write pulse again for any bits read as 1 (reprogramming processing). When all the 0-write bits in the 128-byte write data are read as 0 in the verify-read operation, the program/program-verify procedure is completed. In the H8S/2633, the number of loops in reprogramming processing is guaranteed not to exceed the maximum value of the maximum programming count (N).
  - b. After write pulse application, a verify-read is performed in program-verify mode, and programming is judged to have been completed for bits read as 0.
  - c. If programming of other bits is incomplete in the 128 bytes, reprogramming processing should be executed. If a bit for which programming has been judged to be completed is read as 1 in a subsequent verify-read, a write pulse should again be applied to that bit.
5. The period for which the P1 bit in FLMCR1 is set (the write pulse width) should be changed according to the degree of progress through the program/program-verify procedure. For detailed wait time specifications, see section 25.6 and 26.6, Flash Memory Characteristics.
6. The program/program-verify flowchart for the H8S/2633 is shown in figure 22-12.  
To cover the points noted above, bits on which reprogramming processing is to be executed, and bits on which additional programming is to be executed, must be determined as shown below.  
Since reprogram data and additional-programming data vary according to the progress of the programming procedure, it is recommended that the following data storage areas (128 bytes each) be provided in RAM.

Reprogram Data Computation Table

(D)	Result of Verify-Read after Write Pulse Application (V)	(X) Result of Operation	Comments
0	0	1	Programming completed: reprogramming processing not to be executed
0	1	0	Programming incomplete: reprogramming processing to be executed
1	0	1	—
1	1	1	Still in erased state: no action

**Legend**

- (D): Source data of bits on which programming is executed  
 (X): Source data of bits on which reprogramming is executed

Additional-Programming Data Computation Table

(X')	Result of Verify-Read after Write Pulse Application (V)	(Y) Result of Operation	Comments
0	0	0	Programming by write pulse application judged to be completed: additional programming processing to be executed
0	1	1	Programming by write pulse application incomplete: additional programming processing not to be executed
1	0	1	Programming already completed: additional programming processing not to be executed
1	1	1	Still in erased state: no action

**Legend**

- (Y): Data of bits on which additional programming is executed  
 (X'): Data of bits on which reprogramming is executed in a certain reprogramming loop

7. It is necessary to execute additional programming processing during the course of the H8S/2633 program/program-verify procedure. However, once 128-byte-unit programming is finished, additional programming should not be carried out on the same address area. When executing reprogramming, an erase must be executed first. Note that normal operation of reads, etc., is not guaranteed if additional programming is performed on addresses for which a program/program-verify operation has finished.

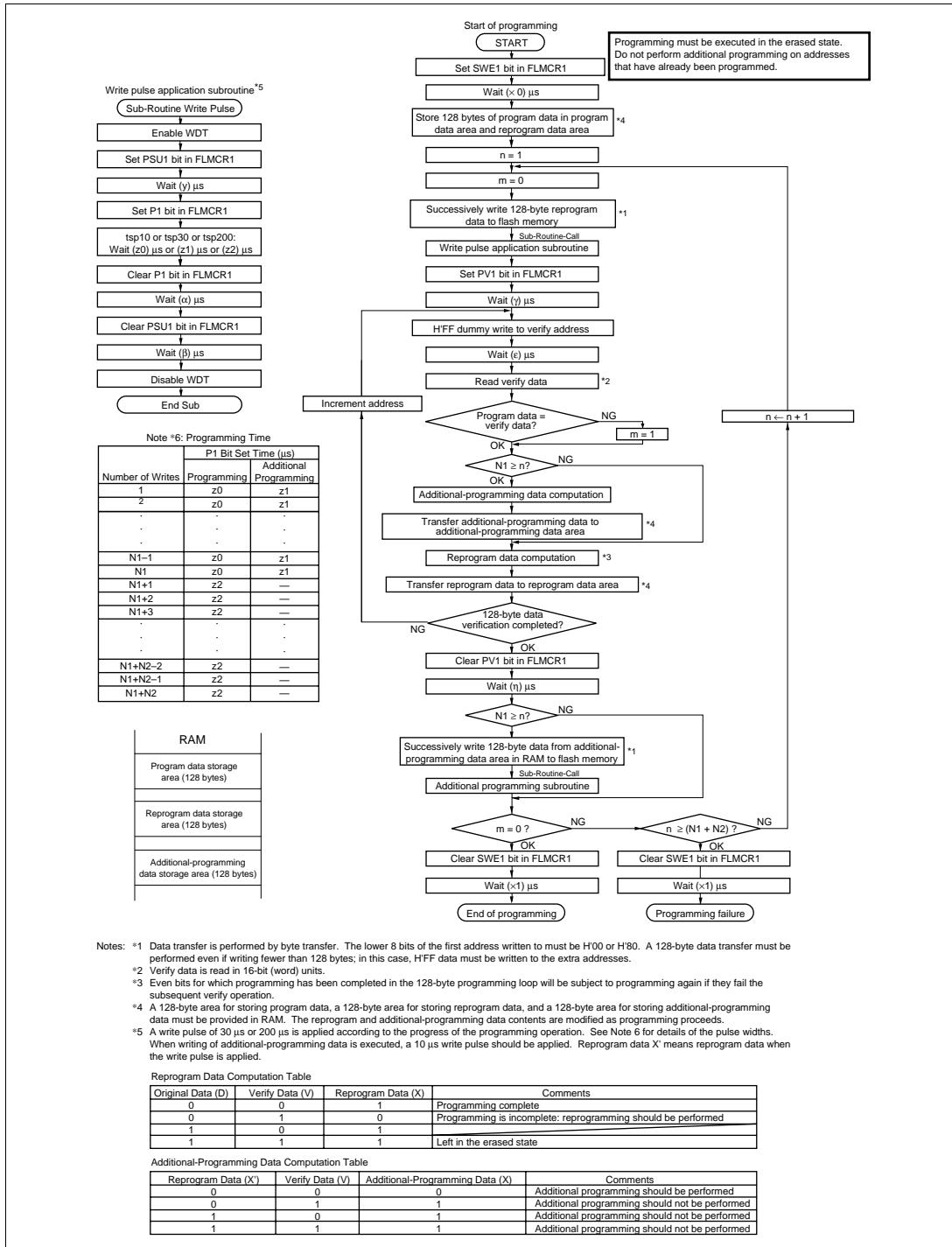


Figure 22-12 Program/Program-Verify Flowchart

### 22.7.3 Erase Mode

When erasing flash memory, the single-block erase/erase-verify flowchart shown in figure 22-13 should be followed.

To erase flash memory contents, make a 1-bit setting for the flash memory area to be erased in erase block register 1 and 2 (EBR1, EBR2) at least (x)  $\mu$ s after setting the SWE1 bit to 1 in FLMCR1. Next, the watchdog timer (WDT) is set to prevent overerasing due to program runaway, etc. Set a value greater than (y + z +  $\alpha$  +  $\beta$ ) ms as the WDT overflow period. Preparation for entering erase mode (erase setup) is performed next by setting the ESU1 bit in FLMCR1. The operating mode is then switched to erase mode by setting the E1 bit in FLMCR1 after the elapse of at least (y)  $\mu$ s. The time during which the E1 bit is set is the flash memory erase time. Ensure that the erase time does not exceed (z) ms.

Note: With flash memory erasing, preprogramming (setting all memory data in the memory to be erased to all 0) is not necessary before starting the erase procedure.

### 22.7.4 Erase-Verify Mode

In erase-verify mode, data is read after memory has been erased to check whether it has been correctly erased.

After the elapse of the fixed erase time, clear the E1 bit in FLMCR1, then wait for at least ( $\alpha$ )  $\mu$ s before clearing the ESU1 bit to exit erase mode. After exiting erase mode, the watchdog timer is cleared after the elapse of ( $\beta$ )  $\mu$ s or more. The operating mode is then switched to erase-verify mode by setting the EV1 bit in FLMCR1. Before reading in erase-verify mode, a dummy write of H'FF data should be made to the addresses to be read. The dummy write should be executed after the elapse of ( $\gamma$ )  $\mu$ s or more. When the flash memory is read in this state (verify data is read in 16-bit units), the data at the latched address is read. Wait at least ( $\epsilon$ )  $\mu$ s after the dummy write before performing this read operation. If the read data has been erased (all 1), a dummy write is performed to the next address, and erase-verify is performed. If the read data is unerased, set erase mode again and repeat the erase/erase-verify sequence in the same way. The maximum number of reoperations of the erase/erase-verify sequence is indicated by the maximum erase count (N). However, ensure that the erase/erase-verify sequence is not repeated more than (N) times. When verification is completed, exit erase-verify mode, and wait for at least ( $\eta$ )  $\mu$ s. If erasure has been completed on all the erase blocks, clear the SWE1 bit in FLMCR1. If there are any unerased blocks, make a 1 bit setting for the flash memory area to be erased, and repeat the erase/erase-verify sequence as before.

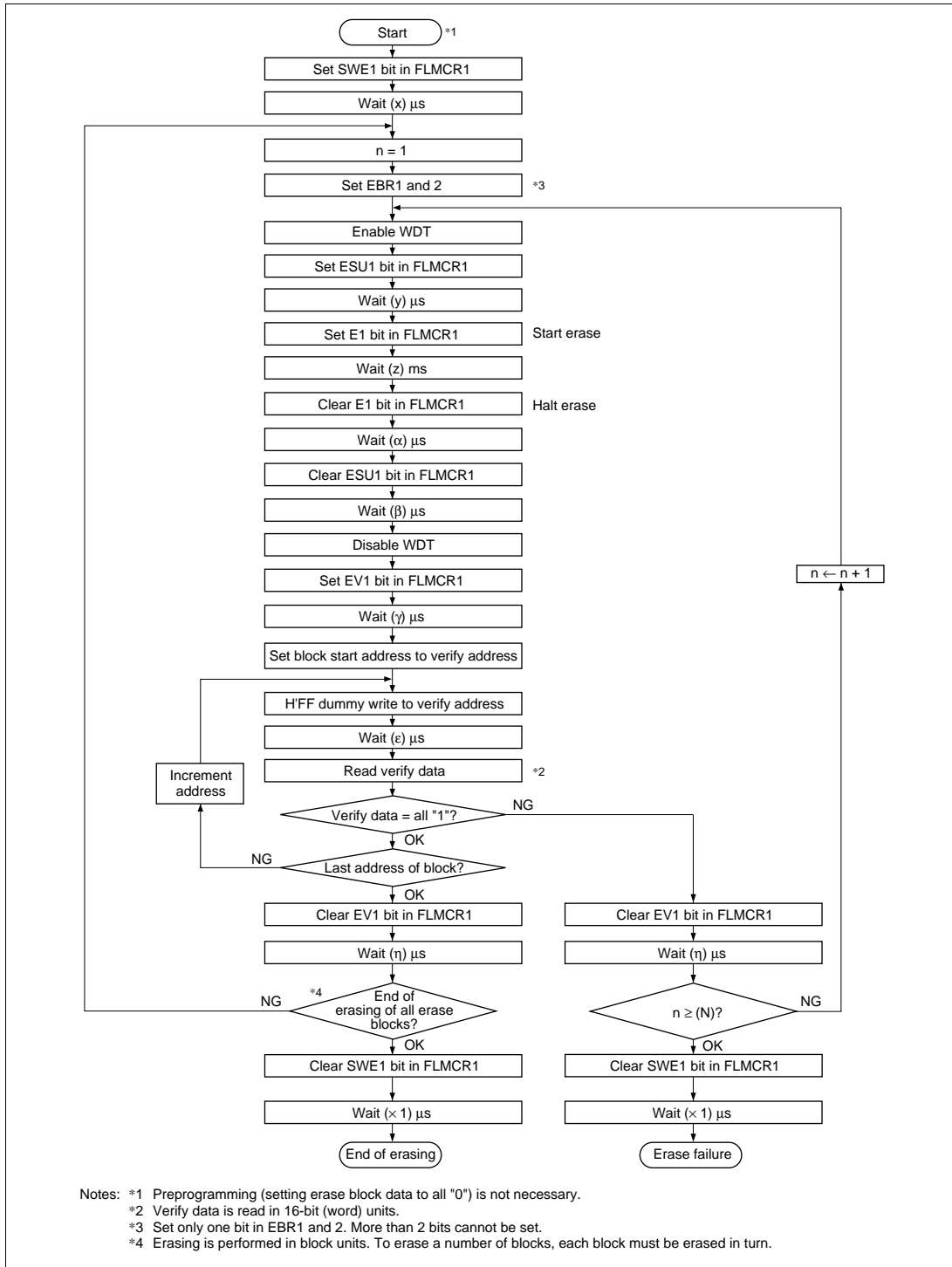


Figure 22-13 Erase/Erase-Verify Flowchart



## 22.8 Protection

There are three kinds of flash memory program/erase protection: hardware protection, software protection, and error protection.

### 22.8.1 Hardware Protection

Hardware protection refers to a state in which programming/erasing of flash memory is forcibly disabled or aborted. Hardware protection is reset by settings in flash memory control register 1 (FLMCR1), flash memory control register 2 (FLMCR2), erase block register 1 (EBR1), and erase block register 2 (EBR2). The FLMCR1, FLMCR2, EBR1, and EBR2 settings are retained in the error-protected state. (See table 22-11.)

**Table 22-11 Hardware Protection**

Item	Description	Functions	
		Program	Erase
FWE pin protection	<ul style="list-style-type: none"><li>When a low level is input to the FWE pin, FLMCR1, FLMCR2, (except bit FLER) EBR1, and EBR2 are initialized, and the program/erase-protected state is entered.</li></ul>	Yes	Yes
Reset/standby protection	<ul style="list-style-type: none"><li>In a power-on reset (including a WDT power-on reset) and in standby mode, FLMCR1, FLMCR2, EBR1, and EBR2 are initialized, and the program/erase-protected state is entered.</li><li>In a reset via the <math>\overline{\text{RES}}</math> pin, the reset state is not entered unless the <math>\overline{\text{RES}}</math> pin is held low until oscillation stabilizes after powering on. In the case of a reset during operation, hold the <math>\overline{\text{RES}}</math> pin low for the <math>\overline{\text{RES}}</math> pulse width specified in the AC Characteristics section.</li></ul>	Yes	Yes

### 22.8.2 Software Protection

Software protection can be implemented by setting the SWE1 bit in FLMCR1, erase block register 1 (EBR1), erase block register 2 (EBR2), and the RAMS bit in the RAM emulation register (RAMER). When software protection is in effect, setting the P1 or E1 bit in flash memory control register 1 (FLMCR1), does not cause a transition to program mode or erase mode. (See table 22-12.)

**Table 22-12 Software Protection**

Item	Description	Functions	
		Program	Erase
SWE bit protection	<ul style="list-style-type: none"> <li>Setting bit SWE1 in FLMCR1 to 0 will place area H'000000 to H'03FFFF in the program/erase-protected state (Execute the program in the on-chip RAM, external memory).</li> </ul>	Yes	Yes
Block specification protection	<ul style="list-style-type: none"> <li>Erase protection can be set for individual blocks by settings in erase block register 1 (EBR1) and erase block register 2 (EBR2).</li> <li>Setting EBR1 and EBR2 to H'00 places all blocks in the erase-protected state.</li> </ul>	—	Yes
Emulation protection	<ul style="list-style-type: none"> <li>Setting the RAMS bit to 1 in the RAM emulation register (RAMER) places all blocks in the program/erase-protected state.</li> </ul>	Yes	Yes

### 22.8.3 Error Protection

In error protection, an error is detected when H8S/2633 Series runaway occurs during flash memory programming/erasing, or operation is not performed in accordance with the program/erase algorithm, and the program/erase operation is aborted. Aborting the program/erase operation prevents damage to the flash memory due to overprogramming or overerasing.

If the H8S/2633 Series malfunctions during flash memory programming/erasing, the FLER bit is set to 1 in FLMCR2 and the error protection state is entered. The FLMCR1, FLMCR2, EBR1, and EBR2 settings are retained, but program mode or erase mode is aborted at the point at which the error occurred. Program mode or erase mode cannot be re-entered by re-setting the P1 or E1 bit. However, PV1 and EV1 bit setting is enabled, and a transition can be made to verify mode.

FLER bit setting conditions are as follows:

1. When the flash memory of the relevant address area is read during programming/erasing (including vector read and instruction fetch)
2. Immediately after exception handling (excluding a reset) during programming/erasing
3. When a SLEEP instruction (including software standby) is executed during programming/erasing
4. When the CPU releases the bus to the DTC

Error protection is released only by a power-on reset and in hardware standby mode.

Figure 22-14 shows the flash memory state transition diagram.

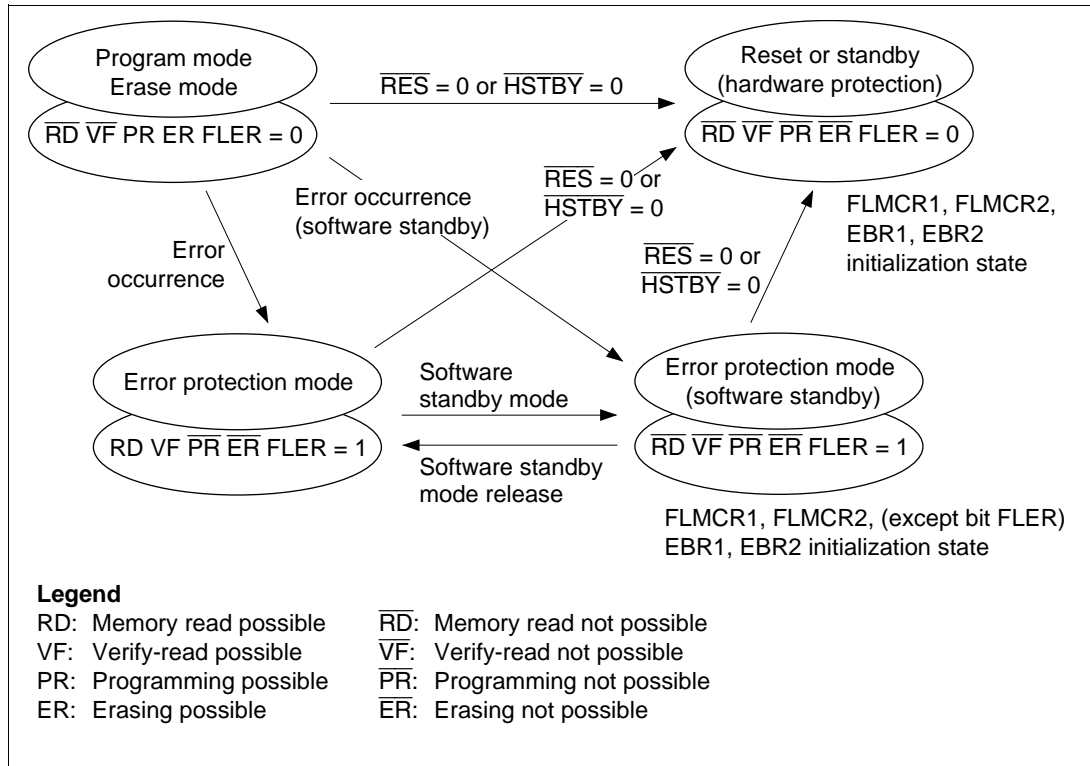


Figure 22-14 Flash Memory State Transitions

## 22.9 Flash Memory Emulation in RAM

Making a setting in the RAM emulation register (RAMER) enables part of RAM to be overlapped onto the flash memory area so that data to be written to flash memory can be emulated in RAM in real time. After the RAMER setting has been made, accesses cannot be made from the flash memory area or the RAM area overlapping flash memory. Emulation can be performed in user mode and user program mode. Figure 22-15 shows an example of emulation of real-time flash memory programming.

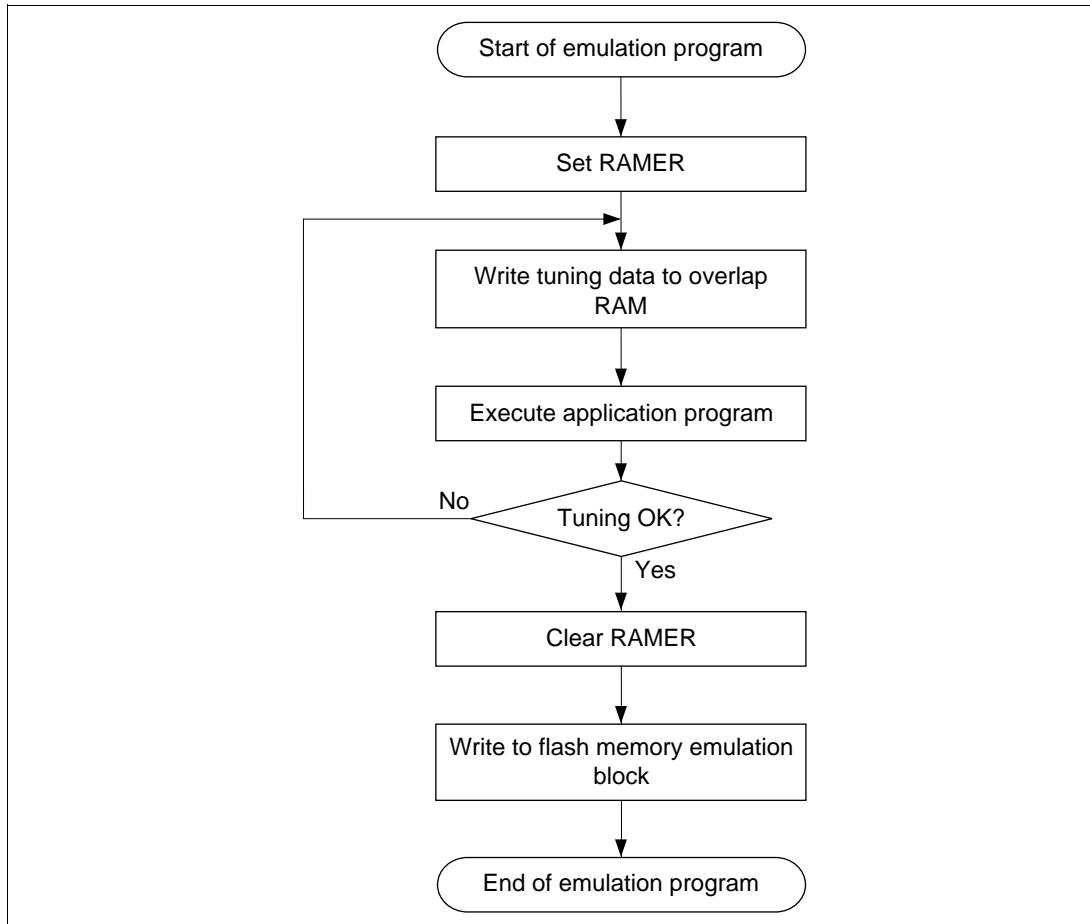
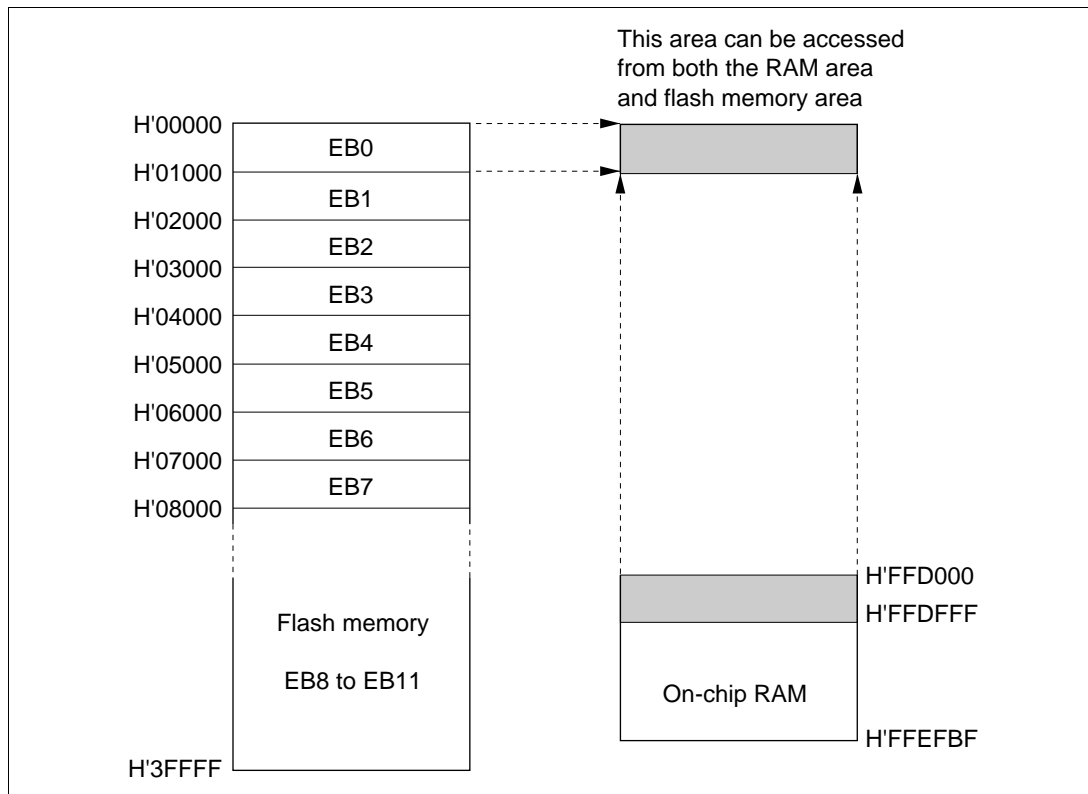


Figure 22-15 Flowchart for Flash Memory Emulation in RAM



**Figure 22-16 Example of RAM Overlap Operation**

**Example in which Flash Memory Block Area EB0 is Overlapped**

1. Set bits RAMS, RAM2 to RAM0 in RAMER to 1, 0, 0, 0, to overlap part of RAM onto the area (EB0) for which real-time programming is required.
2. Real-time programming is performed using the overlapping RAM.
3. After the program data has been confirmed, the RAMS bit is cleared, releasing RAM overlap.
4. The data written in the overlapping RAM is written into the flash memory space (EB0).

- Notes:
1. When the RAMS bit is set to 1, program/erase protection is enabled for all blocks regardless of the value of RAM2 to RAM0 (emulation protection). In this state, setting the P1 or E1 bit in flash memory control register 1 (FLMCR1), will not cause a transition to program mode or erase mode. When actually programming or erasing a flash memory area, the RAMS bit should be cleared to 0.
  2. A RAM area cannot be erased by execution of software in accordance with the erase algorithm while flash memory emulation in RAM is being used.
  3. Block area EB0 contains the vector table. When performing RAM emulation, the vector table is needed in the overlap RAM.

## 22.10 Interrupt Handling when Programming/Erasing Flash Memory

All interrupts, including NMI interrupt is disabled when flash memory is being programmed or erased (when the P1 or E1 bit is set in FLMCR1), and while the boot program is executing in boot mode\*<sup>1</sup>, to give priority to the program or erase operation. There are three reasons for this:

1. Interrupt during programming or erasing might cause a violation of the programming or erasing algorithm, with the result that normal operation could not be assured.
2. In the interrupt exception handling sequence during programming or erasing, the vector would not be read correctly\*<sup>2</sup>, possibly resulting in MCU runaway.
3. If interrupt occurred during boot program execution, it would not be possible to execute the normal boot mode sequence.

For these reasons, in on-board programming mode alone there are conditions for disabling interrupt, as an exception to the general rule. However, this provision does not guarantee normal erasing and programming or MCU operation. All requests, including NMI interrupt, must therefore be restricted inside and outside the MCU when programming or erasing flash memory. NMI interrupt is also disabled in the error-protection state while the P1 or E1 bit remains set in FLMCR1.

Notes: \*1 Interrupt requests must be disabled inside and outside the MCU until the programming control program has completed programming.

\*2 The vector may not be read correctly in this case for the following two reasons:

- If flash memory is read while being programmed or erased (while the P1 or E1 bit is set in FLMCR1), correct read data will not be obtained (undetermined values will be returned).
- If the interrupt entry in the vector table has not been programmed yet, interrupt exception handling will not be executed correctly.

## 22.11 Flash Memory Programmer Mode

Programs and data can be written and erased in programmer mode as well as in the on-board programming modes. In programmer mode, flash memory read mode, auto-program mode, auto-erase mode, and status read mode are supported. In auto-program mode, auto-erase mode, and status read mode, a status polling procedure is used, and in status read mode, detailed internal signals are output after execution of an auto-program or auto-erase operation.

In programmer mode, set the mode pins to programmer mode (see table 22-13) and input a 12 MHz input clock.

Table 22-13 shows the pin settings for programmer mode. For the pin names in programmer mode, see figure 22-18.

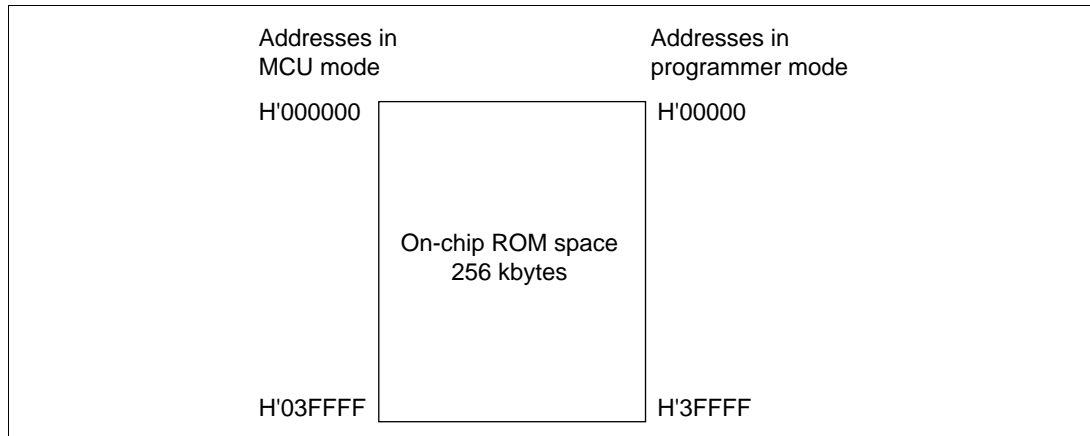
**Table 22-13 Programmer Mode Pin Settings**

<b>Pin Names</b>	<b>Settings</b>
Mode pins: MD2, MD1, MD0	Low level input to MD2, MD1, and MD0.
Mode setting pins: PF0, P16, P14	High level input to PF0, low level input to P16 and P14
FWE pin	High level input (in auto-program and auto-erase modes)
$\overline{\text{RES}}$ pin	Power-on reset circuit
XTAL, EXTAL, PLLVCC*, PLLCAP, PLLVSS pins	Oscillator circuit

Note: \* The H8S/2633R does not have a PLLVCC pin. (The pin in that position is an NC pin.)

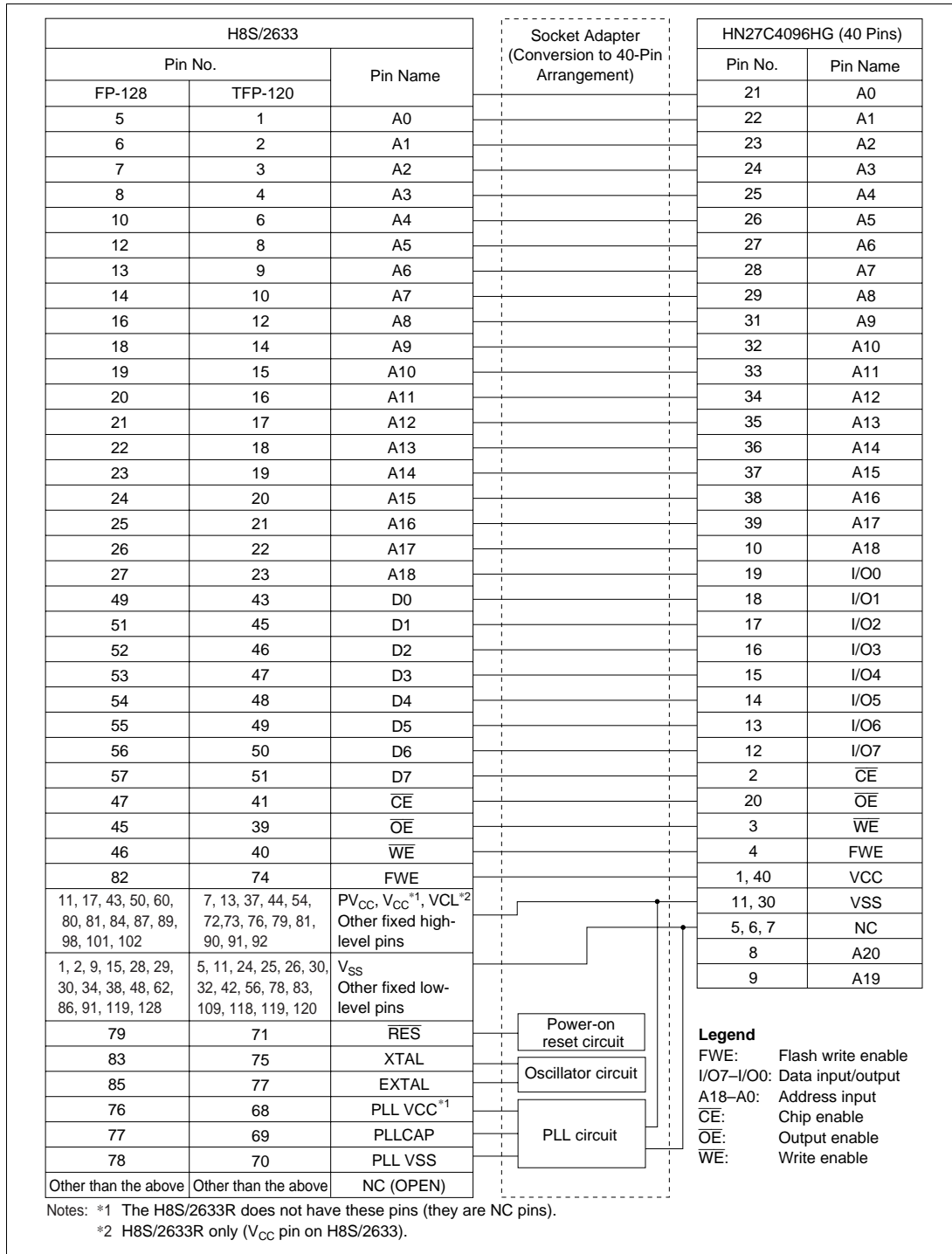
### 22.11.1 Socket Adapter Pin Correspondence Diagram

Connect the socket adapter to the chip as shown in figure 22-18. This will enable conversion to a 40-pin arrangement. The on-chip ROM memory map is shown in figure 22-17, and the socket adapter pin correspondence diagram in figure 22-18.



**Figure 22-17 On-Chip ROM Memory Map**





**Figure 22-18 Socket Adapter Pin Correspondence Diagram**

### 22.11.2 Programmer Mode Operation

Table 22-14 shows how the different operating modes are set when using programmer mode, and table 22-15 lists the commands used in programmer mode. Details of each mode are given below.

- **Memory Read Mode**  
Memory read mode supports byte reads.
- **Auto-Program Mode**  
Auto-program mode supports programming of 128 bytes at a time. Status polling is used to confirm the end of auto-programming.
- **Auto-Erase Mode**  
Auto-erase mode supports automatic erasing of the entire flash memory. Status polling is used to confirm the end of auto-programming.
- **Status Read Mode**  
Status polling is used for auto-programming and auto-erasing, and normal termination can be confirmed by reading the I/O6 signal. In status read mode, error information is output if an error occurs.

**Table 22-14 Settings for Various Operating Modes In Programmer Mode**

Mode	Pin Names					
	FWE	$\overline{CE}$	$\overline{OE}$	$\overline{WE}$	I/O7– I/O0	A18–A0
Read	H or L	L	L	H	Data output	Ain <sup>*2</sup>
Output disable	H or L	L	H	H	Hi-Z	X
Command write	H or L <sup>*3</sup>	L	H	L	Data input	Ain <sup>*2</sup>
Chip disable <sup>*1</sup>	H or L	H	X	X	Hi-Z	X

Notes: \*1 Chip disable is not a standby state; internally, it is an operation state.

\*2 Ain indicates that there is also address input in auto-program mode.

\*3 For command writes in auto-program and auto-erase modes, input a high level to the FWE pin.

**Table 22-15 Programmer Mode Commands**

Command Name	Number of Cycles	1st Cycle			2nd Cycle		
		Mode	Address	Data	Mode	Address	Data
Memory read mode	1 + n	Write	X	H'00	Read	RA	Dout
Auto-program mode	129	Write	X	H'40	Write	WA	Din
Auto-erase mode	2	Write	X	H'20	Write	X	H'20
Status read mode	2	Write	X	H'71	Write	X	H'71

Notes: 1. In auto-program mode, 129 cycles are required for command writing by a simultaneous 128-byte write.  
 2. In memory read mode, the number of cycles depends on the number of address write cycles (n).

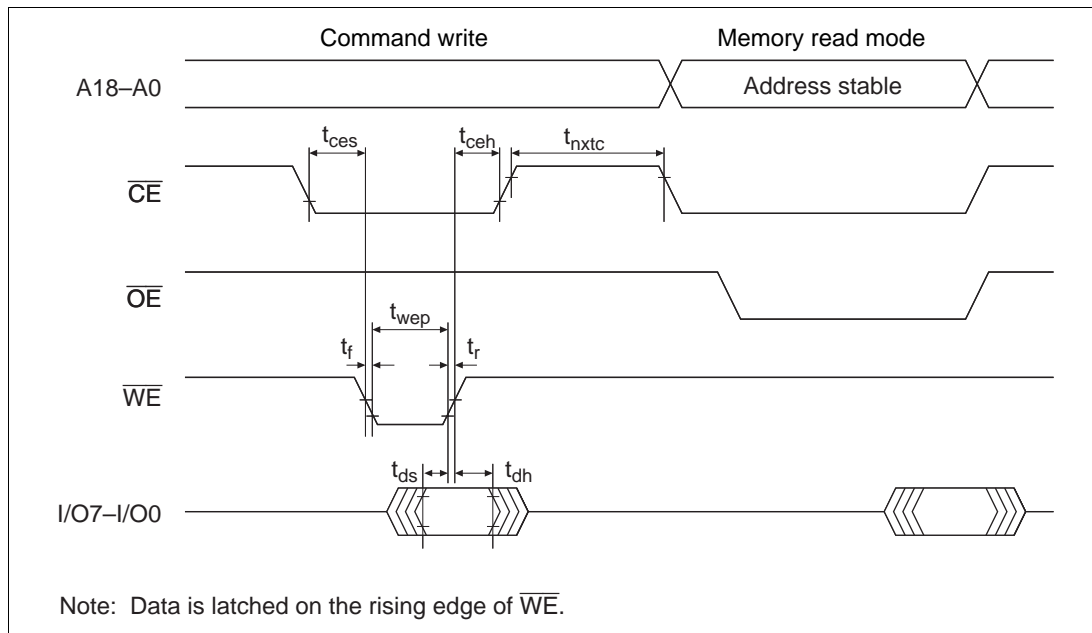
### 22.11.3 Memory Read Mode

1. After completion of auto-program/auto-erase/status read operations, a transition is made to the command wait state. When reading memory contents, a transition to memory read mode must first be made with a command write, after which the memory contents are read.
2. In memory read mode, command writes can be performed in the same way as in the command wait state.
3. Once memory read mode has been entered, consecutive reads can be performed.
4. After powering on, memory read mode is entered.

**Table 22-16 AC Characteristics in Transition to Memory Read Mode**

(Conditions:  $V_{CC} = 3.3\text{ V} \pm 0.3\text{ V}$ ,  $V_{SS} = 0\text{ V}$ ,  $T_a = 25^\circ\text{C} \pm 5^\circ\text{C}$ )

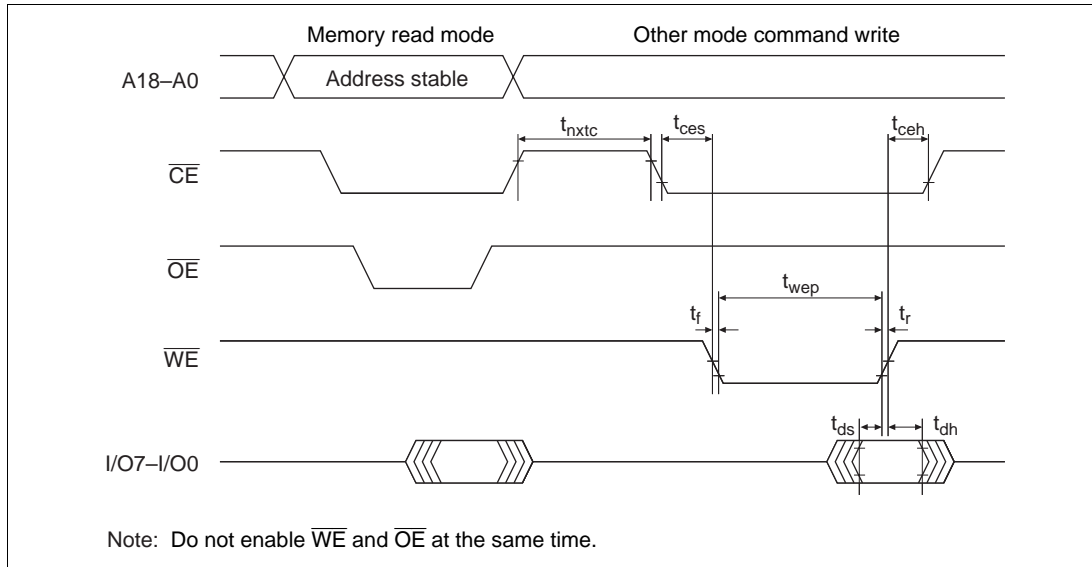
Item	Symbol	Min	Max	Unit
Command write cycle	$t_{nxtc}$	20	—	$\mu\text{s}$
$\overline{\text{CE}}$ hold time	$t_{ceh}$	0	—	ns
$\overline{\text{CE}}$ setup time	$t_{ces}$	0	—	ns
Data hold time	$t_{dh}$	50	—	ns
Data setup time	$t_{ds}$	50	—	ns
Write pulse width	$t_{wep}$	70	—	ns
$\overline{\text{WE}}$ rise time	$t_r$	—	30	ns
$\overline{\text{WE}}$ fall time	$t_f$	—	30	ns



**Figure 22-19 Timing Waveforms for Memory Read after Memory Write**

**Table 22-17 AC Characteristics in Transition from Memory Read Mode to Another Mode**  
(Conditions:  $V_{CC} = 3.3\text{ V} \pm 0.3\text{ V}$ ,  $V_{SS} = 0\text{ V}$ ,  $T_a = 25^\circ\text{C} \pm 5^\circ\text{C}$ )

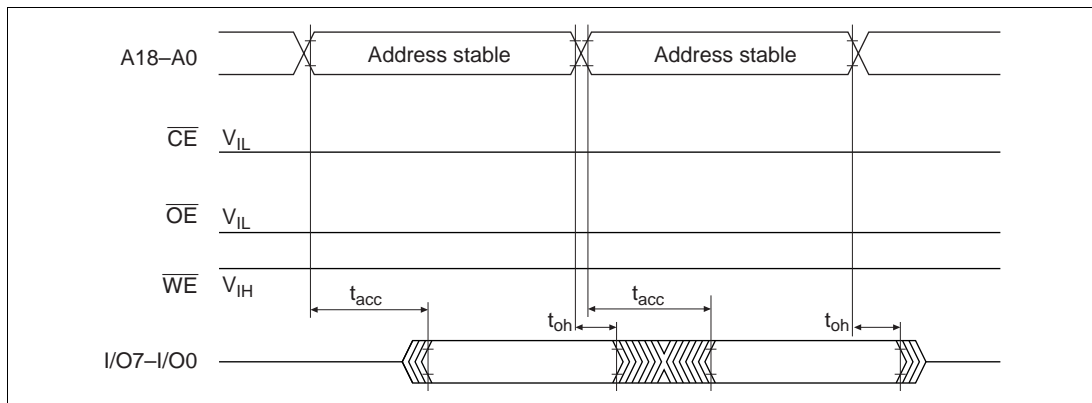
Item	Symbol	Min	Max	Unit
Command write cycle	$t_{nxtc}$	20	—	$\mu\text{s}$
$\overline{CE}$ hold time	$t_{ceh}$	0	—	ns
$\overline{CE}$ setup time	$t_{ces}$	0	—	ns
Data hold time	$t_{dh}$	50	—	ns
Data setup time	$t_{ds}$	50	—	ns
Write pulse width	$t_{wep}$	70	—	ns
$\overline{WE}$ rise time	$t_r$	—	30	ns
$\overline{WE}$ fall time	$t_f$	—	30	ns



**Figure 22-20 Timing Waveforms in Transition from Memory Read Mode to Another Mode**

**Table 22-18 AC Characteristics in Memory Read Mode (Conditions:  $V_{CC} = 3.3\text{ V} \pm 0.3\text{ V}$ ,  $V_{SS} = 0\text{ V}$ ,  $T_a = 25^\circ\text{C} \pm 5^\circ\text{C}$ )**

Item	Symbol	Min	Max	Unit
Access time	$t_{acc}$	—	20	$\mu\text{s}$
$\overline{CE}$ output delay time	$t_{ce}$	—	150	ns
$\overline{OE}$ output delay time	$t_{oe}$	—	150	ns
Output disable delay time	$t_{df}$	—	100	ns
Data output hold time	$t_{oh}$	5	—	ns



**Figure 22-21  $\overline{CE}$  and  $\overline{OE}$  Enable State Read Timing Waveforms**

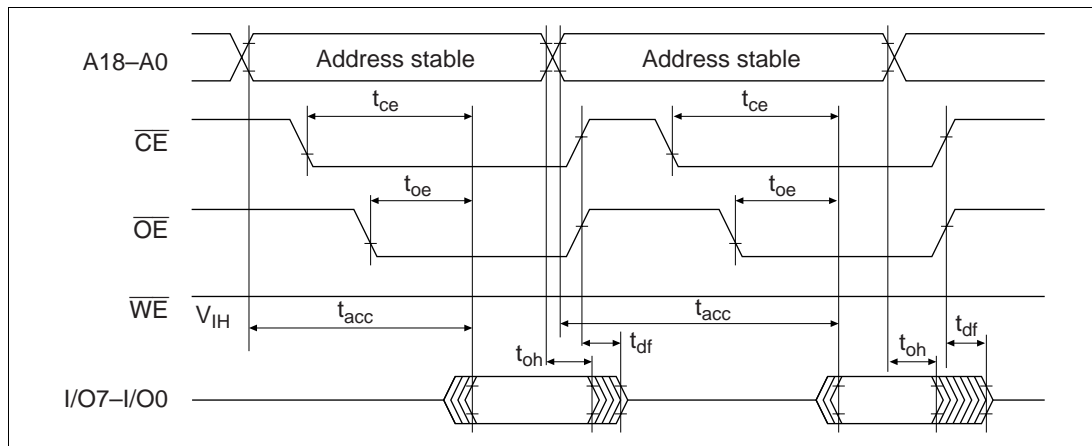


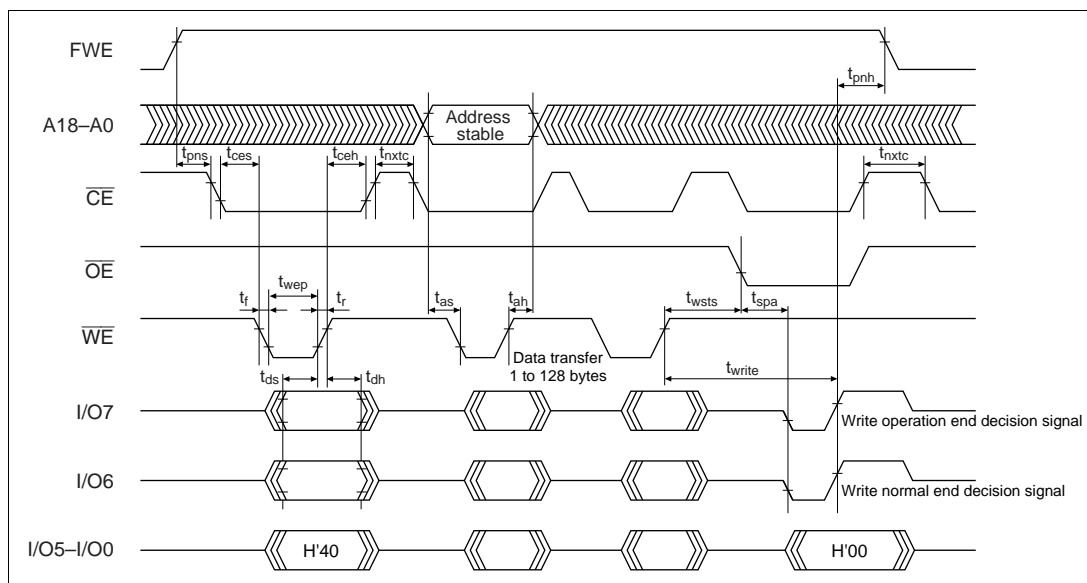
Figure 22-22  $\overline{\text{CE}}$  and  $\overline{\text{OE}}$  Clock System Read Timing Waveforms

#### 22.11.4 Auto-Program Mode

1. In auto-program mode, 128 bytes are programmed simultaneously. This should be carried out by executing 128 consecutive byte transfers.
2. A 128-byte data transfer is necessary even when programming fewer than 128 bytes. In this case, H'FF data must be written to the extra addresses.
3. The lower 7 bits of the transfer address must be low. If a value other than an effective address is input, processing will switch to a memory write operation but a write error will be flagged.
4. Memory address transfer is performed in the second cycle (figure 22-23). Do not perform transfer after the third cycle.
5. Do not perform a command write during a programming operation.
6. Perform one auto-program operation for a 128-byte block for each address. Two or more additional programming operations cannot be performed on a previously programmed address block.
7. Confirm normal end of auto-programming by checking I/O6. Alternatively, status read mode can also be used for this purpose (I/O7 status polling uses the auto-program operation end decision pin).
8. Status polling I/O6 and I/O7 pin information is retained until the next command write. As long as the next command write has not been performed, reading is possible by enabling  $\overline{\text{CE}}$  and  $\overline{\text{OE}}$ .

**Table 22-19 AC Characteristics in Auto-Program Mode (Conditions:  $V_{CC} = 3.3\text{ V} \pm 0.3\text{ V}$ ,  $V_{SS} = 0\text{ V}$ ,  $T_a = 25^\circ\text{C} \pm 5^\circ\text{C}$ )**

Item	Symbol	Min	Max	Unit
Command write cycle	$t_{nxtc}$	20	—	$\mu\text{s}$
$\overline{\text{CE}}$ hold time	$t_{ceh}$	0	—	ns
$\overline{\text{CE}}$ setup time	$t_{ces}$	0	—	ns
Data hold time	$t_{dh}$	50	—	ns
Data setup time	$t_{ds}$	50	—	ns
Write pulse width	$t_{wep}$	70	—	ns
Status polling start time	$t_{wsts}$	1	—	ms
Status polling access time	$t_{spa}$	—	150	ns
Address setup time	$t_{as}$	0	—	ns
Address hold time	$t_{ah}$	60	—	ns
Memory write time	$t_{write}$	1	3000	ms
Write setup time	$t_{pns}$	100	—	ns
Write end setup time	$t_{prh}$	100	—	ns
$\overline{\text{WE}}$ rise time	$t_r$	—	30	ns
$\overline{\text{WE}}$ fall time	$t_f$	—	30	ns



**Figure 22-23 Auto-Program Mode Timing Waveforms**

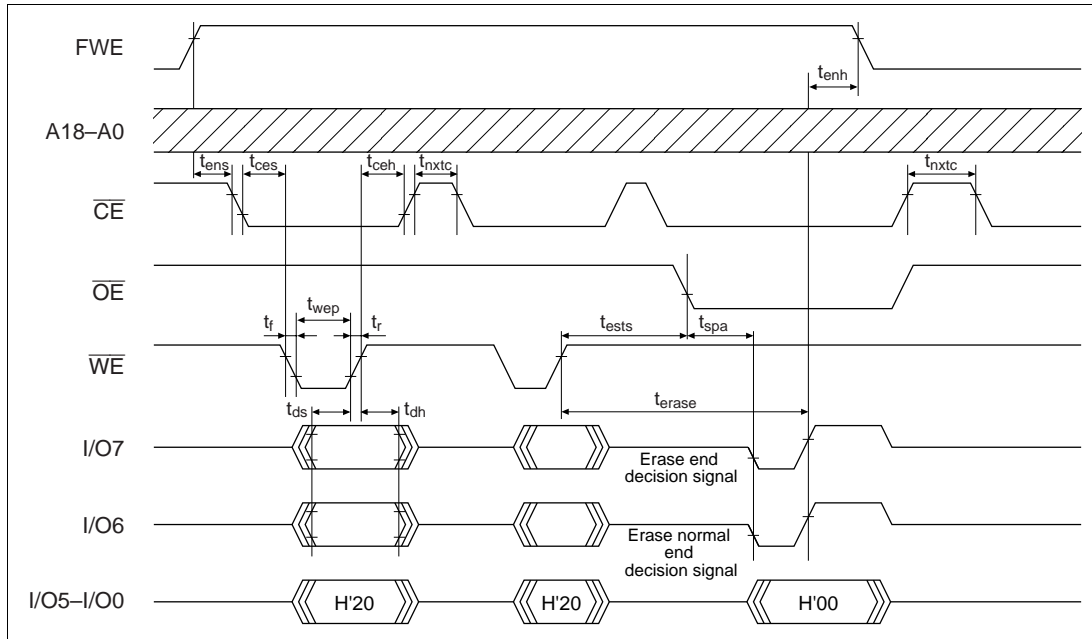
### 22.11.5 Auto-Erase Mode

1. Auto-erase mode supports only entire memory erasing.
2. Do not perform a command write during auto-erasing.
3. Confirm normal end of auto-erasing by checking I/O6. Alternatively, status read mode can also be used for this purpose (I/O7 status polling uses the auto-erase operation end decision pin).
4. Status polling I/O6 and I/O7 pin information is retained until the next command write. As long as the next command write has not been performed, reading is possible by enabling  $\overline{\text{CE}}$  and  $\overline{\text{OE}}$ .

**Table 22-20 AC Characteristics in Auto-Erase Mode (Conditions:  $V_{CC} = 3.3 \text{ V} \pm 0.3 \text{ V}$ ,  $V_{SS} = 0 \text{ V}$ ,  $T_a = 25^\circ\text{C} \pm 5^\circ\text{C}$ )**

Item	Symbol	Min	Max	Unit
Command write cycle	$t_{\text{nxtc}}$	20	—	$\mu\text{s}$
$\overline{\text{CE}}$ hold time	$t_{\text{ceh}}$	0	—	ns
$\overline{\text{CE}}$ setup time	$t_{\text{ces}}$	0	—	ns
Data hold time	$t_{\text{dh}}$	50	—	ns
Data setup time	$t_{\text{ds}}$	50	—	ns
Write pulse width	$t_{\text{wep}}$	70	—	ns
Status polling start time	$t_{\text{ests}}$	1	—	ms
Status polling access time	$t_{\text{spa}}$	—	150	ns
Memory erase time	$t_{\text{erase}}$	100	40000	ms
Erase setup time	$t_{\text{ens}}$	100	—	ns
Erase end setup time	$t_{\text{enh}}$	100	—	ns
$\overline{\text{WE}}$ rise time	$t_{\text{r}}$	—	30	ns
$\overline{\text{WE}}$ fall time	$t_{\text{f}}$	—	30	ns





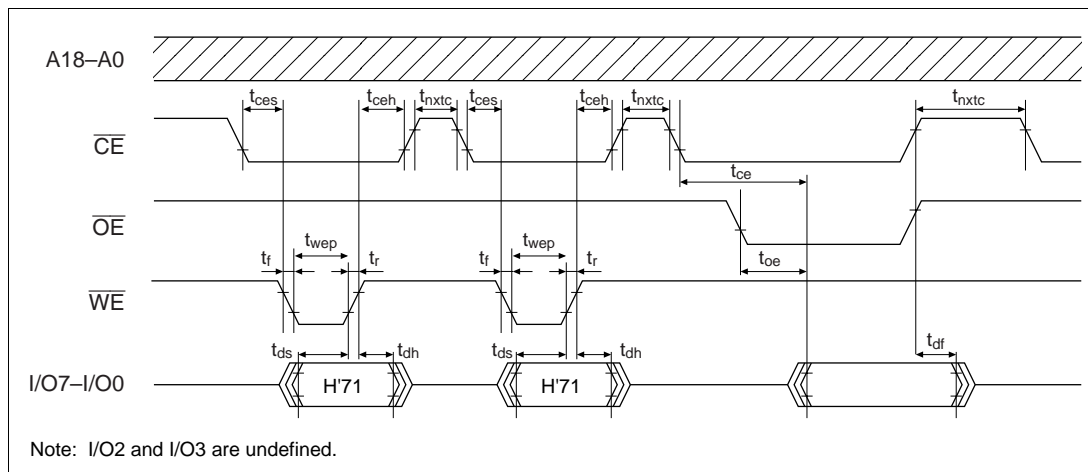
**Figure 22-24 Auto-Erase Mode Timing Waveforms**

### 22.11.6 Status Read Mode

1. Status read mode is provided to identify the kind of abnormal end. Use this mode when an abnormal end occurs in auto-program mode or auto-erase mode.
2. The return code is retained until a command write other than a status read mode command write is executed.

**Table 22-21 AC Characteristics in Status Read Mode (Conditions:  $V_{CC} = 3.3\text{ V} \pm 0.3\text{ V}$ ,  $V_{SS} = 0\text{ V}$ ,  $T_a = 25^\circ\text{C} \pm 5^\circ\text{C}$ )**

Item	Symbol	Min	Max	Unit
Read time after command write	$t_{nxtc}$	20	—	$\mu\text{s}$
$\overline{\text{CE}}$ hold time	$t_{ceh}$	0	—	ns
$\overline{\text{CE}}$ setup time	$t_{ces}$	0	—	ns
Data hold time	$t_{dh}$	50	—	ns
Data setup time	$t_{ds}$	50	—	ns
Write pulse width	$t_{wep}$	70	—	ns
$\overline{\text{OE}}$ output delay time	$t_{oe}$	—	150	ns
Disable delay time	$t_{df}$	—	100	ns
$\overline{\text{CE}}$ output delay time	$t_{ce}$	—	150	ns
$\overline{\text{WE}}$ rise time	$t_r$	—	30	ns
$\overline{\text{WE}}$ fall time	$t_f$	—	30	ns



**Figure 22-25 Status Read Mode Timing Waveforms**

**Table 22-22 Status Read Mode Return Commands**

Pin Name	I/O7	I/O6	I/O5	I/O4	I/O3	I/O2	I/O1	I/O0
Attribute	Normal end decision	Command error	Programming error	Erase error	—	—	Programming or erase count exceeded	Effective address error
Initial value	0	0	0	0	0	0	0	0
Indications	Normal end: 0 Abnormal end: 1	Command error: 1 Otherwise: 0	Programming error: 1 Otherwise: 0	Erasing error: 1 Otherwise: 0	—	—	Count exceeded: 1 Otherwise: 0	Effective address error: 1 Otherwise: 0

Note: I/O2 and I/O3 are undefined.

### 22.11.7 Status Polling

1. The I/O7 status polling flag indicates the operating status in auto-program/auto-erase mode.
2. The I/O6 status polling flag indicates a normal or abnormal end in auto-program/auto-erase mode.

**Table 22-23 Status Polling Output Truth Table**

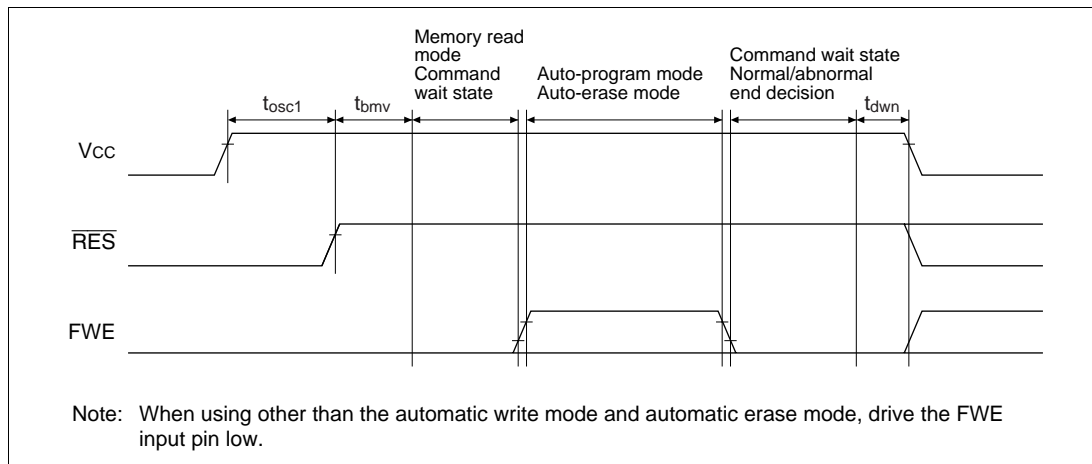
Pin Name	During Internal Operation	Abnormal End	—	Normal End
I/O7	0	1	0	1
I/O6	0	0	1	1
I/O0–I/O5	0	0	0	0

### 22.11.8 Programmer Mode Transition Time

Commands cannot be accepted during the oscillation stabilization period or the programmer mode setup period. After the programmer mode setup time, a transition is made to memory read mode.

**Table 22-24 Stipulated Transition Times to Command Wait State**

Item	Symbol	Min	Max	Unit
Standby release (oscillation stabilization time)	$t_{osc1}$	30	—	ms
Programmer mode setup time	$t_{bmv}$	10	—	ms
$V_{CC}$ hold time	$t_{dwn}$	0	—	ms



**Figure 22-26 Oscillation Stabilization Time, Boot Program Transfer Time, and Power-Down Sequence**

### 22.11.9 Notes on Memory Programming

1. When programming addresses which have previously been programmed, carry out auto-erasing before auto-programming.
2. When performing programming using programmer mode on a chip that has been programmed/erased in an on-board programming mode, auto-erasing is recommended before carrying out auto-programming.

- Notes:
1. The flash memory is initially in the erased state when the device is shipped by Hitachi. For other chips for which the erasure history is unknown, it is recommended that auto-erasing be executed to check and supplement the initialization (erase) level.
  2. Auto-programming should be performed once only on the same address block. Additional programming cannot be performed on previously programmed address blocks.

## 22.12 Flash Memory and Power-Down States

In addition to its normal operating state, the flash memory has power-down states in which power consumption is reduced by halting part or all of the internal power supply circuitry.

There are three flash memory operating states:

- (1) Normal operating mode: The flash memory can be read and written to.
- (2) Power-down mode: Part of the power supply circuitry is halted, and the flash memory can be read when the H8S/2633 is operating on the subclock.
- (3) Standby mode: All flash memory circuits are halted, and the flash memory cannot be read or written to.

States (2) and (3) are flash memory power-down states. Table 22-25 shows the correspondence between the operating states of the H8S/2633 and the flash memory.

**Table 22-25 Flash Memory Operating States**

LSI Operating State	Flash Memory Operating State
High-speed mode	Normal mode (read/write)
Medium-speed mode	
Sleep mode	
Subactive mode	When PDWND = 0: Power-down mode (read-only)
Subsleep mode	When PDWND = 1: Normal mode (read-only)
Watch mode	Standby mode
Software standby mode	
Hardware standby mode	

### 22.12.1 Note on Power-Down States

When the flash memory is in a power-down state, part or all of the internal power supply circuitry is halted. Therefore, a power supply circuit stabilization period must be provided when returning to normal operation. When the flash memory returns to its normal operating state from a power-down state, bits STS2 to STS0 in SBYCR must be set to provide a wait time of at least 20  $\mu$ s (power supply stabilization time), even if an oscillation stabilization period is not necessary.

## 22.13 Flash Memory Programming and Erasing Precautions

Precautions concerning the use of on-board programming mode, the RAM emulation function, and programmer mode are summarized below.

**Use the specified voltages and timing for programming and erasing:** Applied voltages in excess of the rating can permanently damage the device. Use a PROM programmer that supports the Hitachi microcomputer device type with 256-kbyte on-chip flash memory (FZTAT256V3A).

Do not select the HN27C4096 setting for the PROM programmer, and only use the specified socket adapter. Failure to observe these points may result in damage to the device.

**Powering on and off (see figures 22-27 to 22-29):** Do not apply a high level to the FWE pin until  $V_{CC}$  has stabilized. Also, drive the FWE pin low before turning off  $V_{CC}$ .

When applying or disconnecting  $V_{CC}$  power, fix the FWE pin low and place the flash memory in the hardware protection state.

The power-on and power-off timing requirements should also be satisfied in the event of a power failure and subsequent recovery.

**FWE application/disconnection (see figures 22-27 to 22-29):** FWE application should be carried out when MCU operation is in a stable condition. If MCU operation is not stable, fix the FWE pin low and set the protection state.

The following points must be observed concerning FWE application and disconnection to prevent unintentional programming or erasing of flash memory:

- Apply FWE when the  $V_{CC}$  voltage has stabilized within its rated voltage range.  
Apply FWE when oscillation has stabilized (after the elapse of the oscillation stabilization time).
- In boot mode, apply and disconnect FWE during a reset.
- In user program mode, FWE can be switched between high and low level regardless of the reset state. FWE input can also be switched during execution of a program in flash memory.
- Do not apply FWE if program runaway has occurred.
- Disconnect FWE only when the SWE1, ESU1, PSU1, EV1, PV1, P1, and E1 bits in FLMCR1 are cleared.

Make sure that the SWE1, ESU1, PSU1, EV1, PV1, P1, and E1 bits are not set by mistake when applying or disconnecting FWE.

**Do not apply a constant high level to the FWE pin:** Apply a high level to the FWE pin only when programming or erasing flash memory. A system configuration in which a high level is constantly applied to the FWE pin should be avoided. Also, while a high level is applied to the FWE pin, the watchdog timer should be activated to prevent overprogramming or overerasing due to program runaway, etc.

**Use the recommended algorithm when programming and erasing flash memory:** The recommended algorithm enables programming and erasing to be carried out without subjecting the device to voltage stress or sacrificing program data reliability. When setting the P1 or E1 bit in FLMCR1, the watchdog timer should be set beforehand as a precaution against program runaway, etc.

**Do not set or clear the SWE1 bit during execution of a program in flash memory:** Wait for at least 100  $\mu$ s after clearing the SWE1 bit before executing a program or reading data in flash memory. When the SWE1 bit is set, data in flash memory can be rewritten, but when SWE1 = 1, flash memory can only be read in program-verify or erase-verify mode. Access flash memory only for verify operations (verification during programming/erasing). Also, do not clear the SWE1 bit during programming, erasing, or verifying.

Similarly, when using the RAM emulation function while a high level is being input to the FWE pin, the SWE1 bit must be cleared before executing a program or reading data in flash memory.

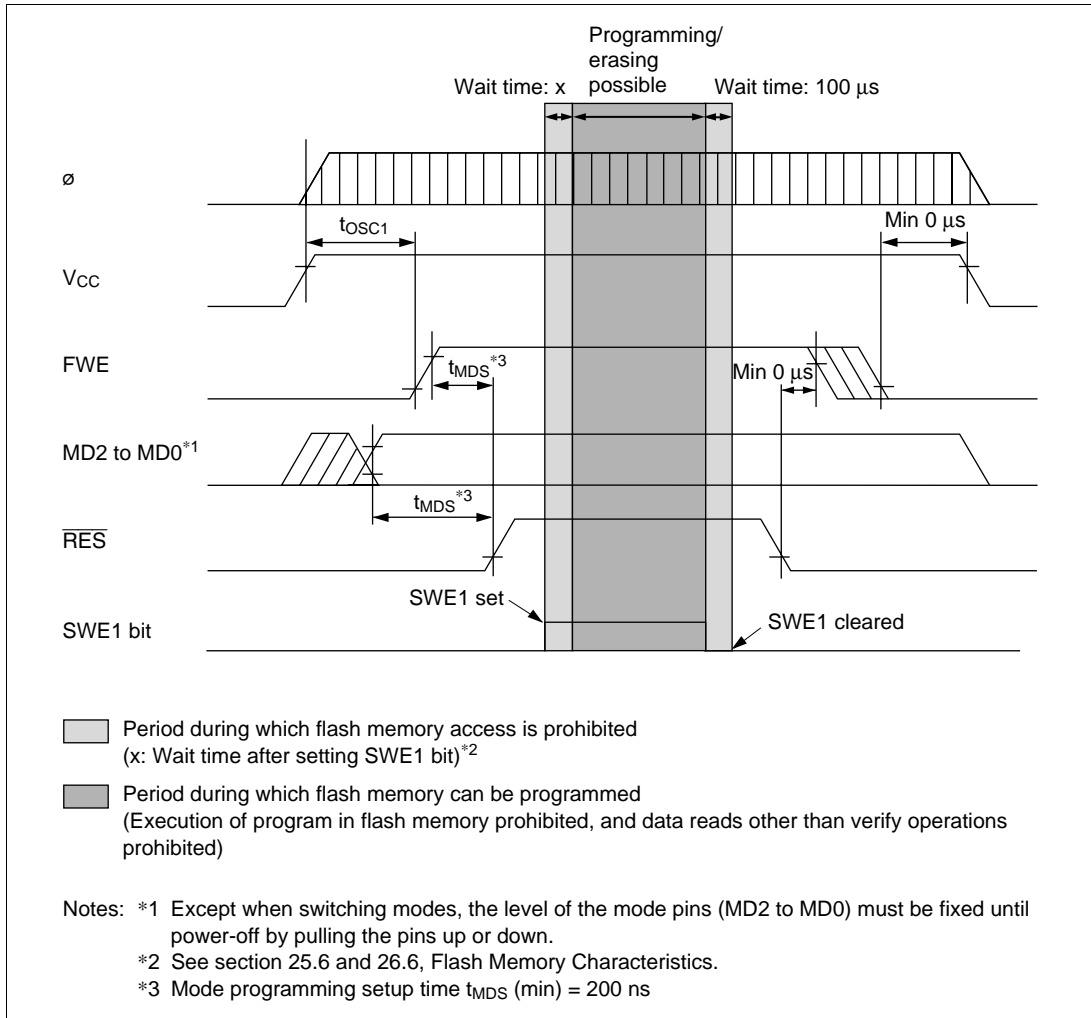
However, the RAM area overlapping flash memory space can be read and written to regardless of whether the SWE1 bit is set or cleared.

**Do not use interrupts while flash memory is being programmed or erased:** All interrupt requests, including NMI, should be disabled during FWE application to give priority to program/erase operations.

**Do not perform overwriting. Erase the memory before reprogramming:** In on-board programming, perform only one programming operation on a 128-byte programming unit block. In programmer mode, too, perform only one programming operation on a 128-byte programming unit block. Programming should be carried out with the entire programming unit block erased.

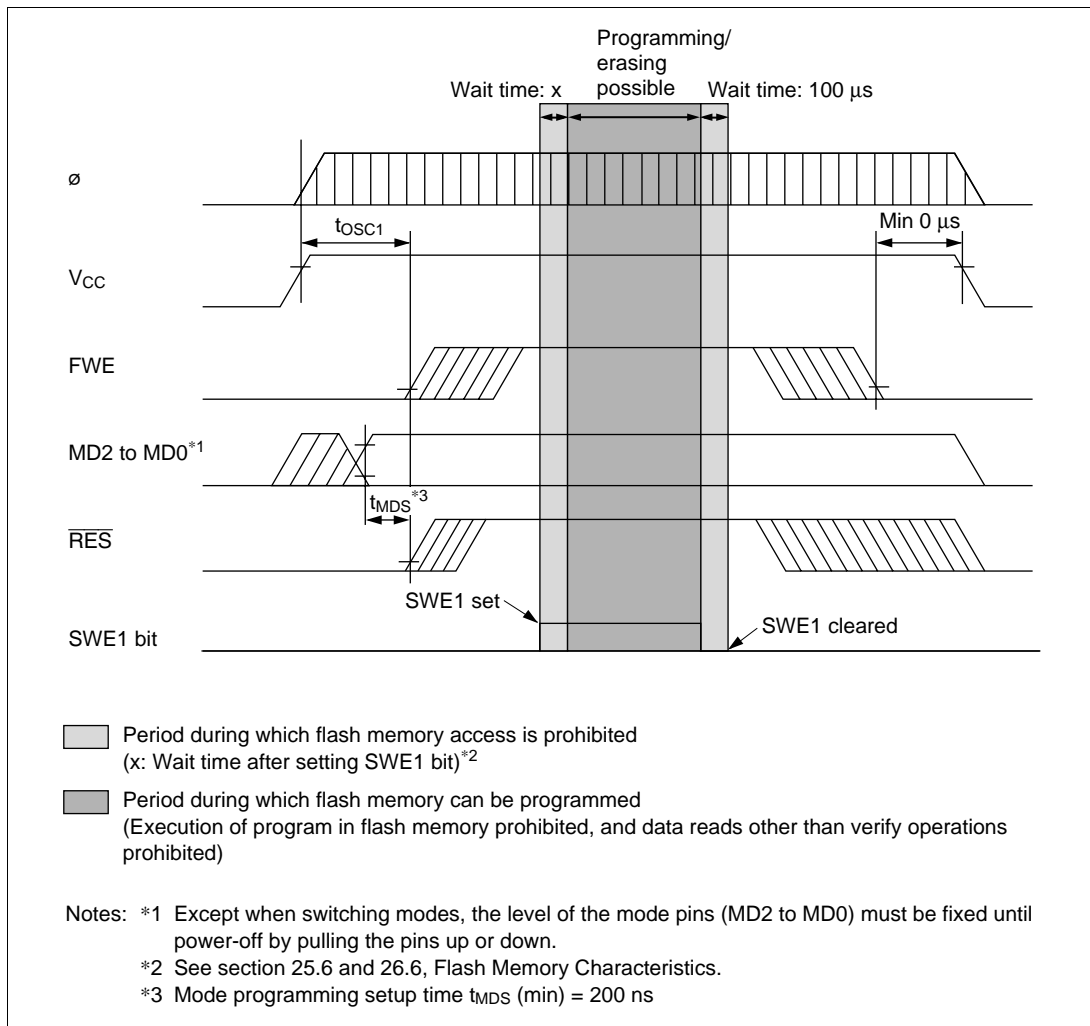
**Before programming, check that the chip is correctly mounted in the PROM programmer:** Overcurrent damage to the device can result if the index marks on the PROM programmer socket, socket adapter, and chip are not correctly aligned.

**Do not touch the socket adapter or chip during programming:** Touching either of these can cause contact faults and write errors.

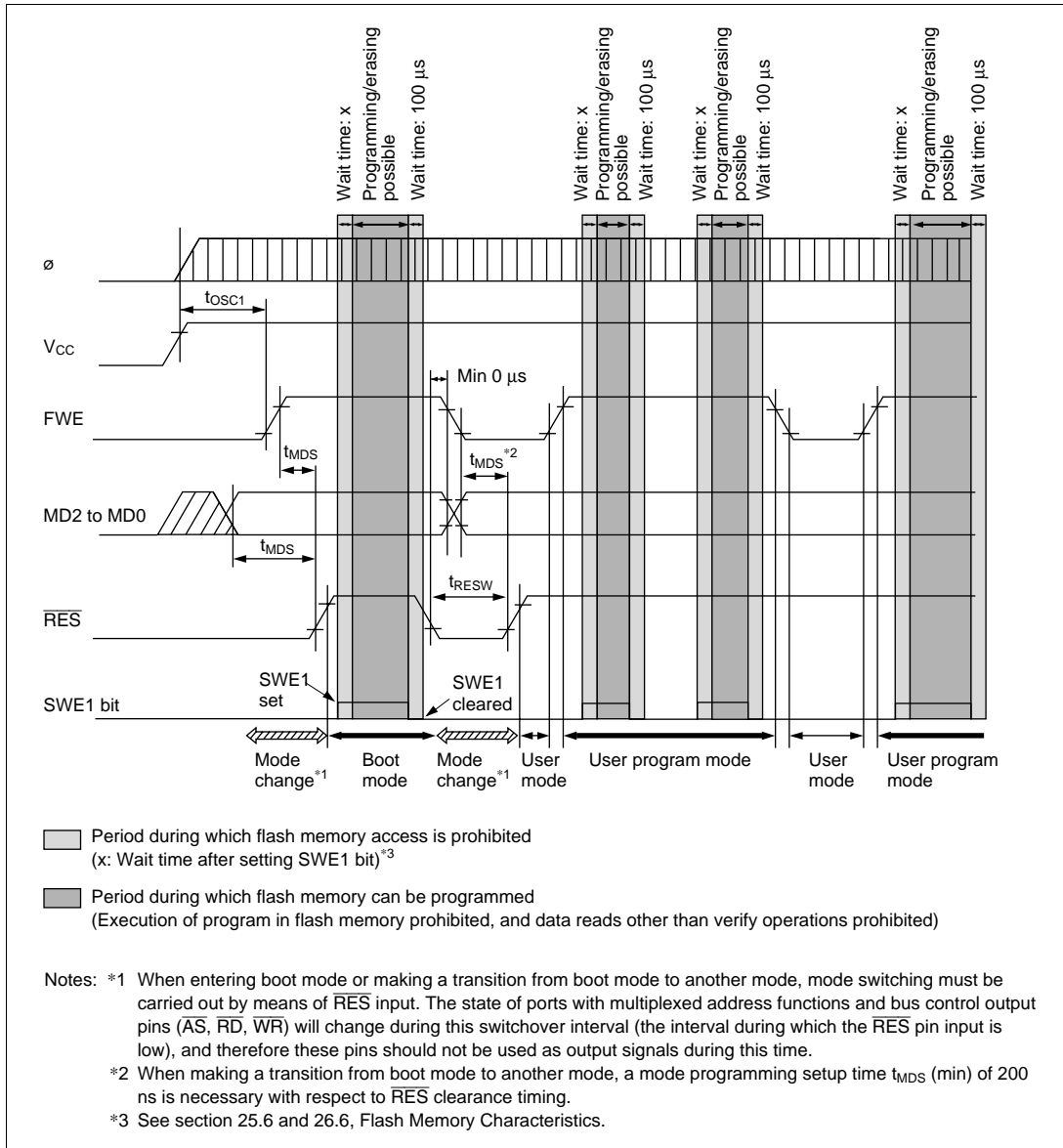


**Figure 22-27 Power-On/Off Timing (Boot Mode)**





**Figure 22-28 Power-On/Off Timing (User Program Mode)**



**Figure 22-29 Mode Transition Timing**  
**(Example: Boot Mode  $\rightarrow$  User Mode  $\leftrightarrow$  User Program Mode)**

## 22.14 Note on Switching from F-ZTAT Version to Mask ROM Version

The mask ROM version does not have the internal registers for flash memory control that are provided in the F-ZTAT version. Table 22-26 lists the registers that are present in the F-ZTAT version but not in the mask ROM version. If a register listed in table 22-26 is read in the mask ROM version, an undefined value will be returned. Therefore, if application software developed on the F-ZTAT version is switched to a mask ROM version product, it must be modified to ensure that the registers in table 22-26 have no effect.

**Table 22-26 Registers Present in F-ZTAT Version but Absent in Mask ROM Version**

<b>Register</b>	<b>Abbreviation</b>	<b>Address</b>
Flash memory control register 1	FLMCR1	H'FFC8
Flash memory control register 2	FLMCR2	H'FFC9
Erase block register 1	EBR1	H'FFCA
Erase block register 2	EBR2	H'FFCB
RAM emulation register	RAMER	H'FEDB



## Section 23A Clock Pulse Generator (H8S/2633, H8S/2632, H8S/2631, H8S/2633F)

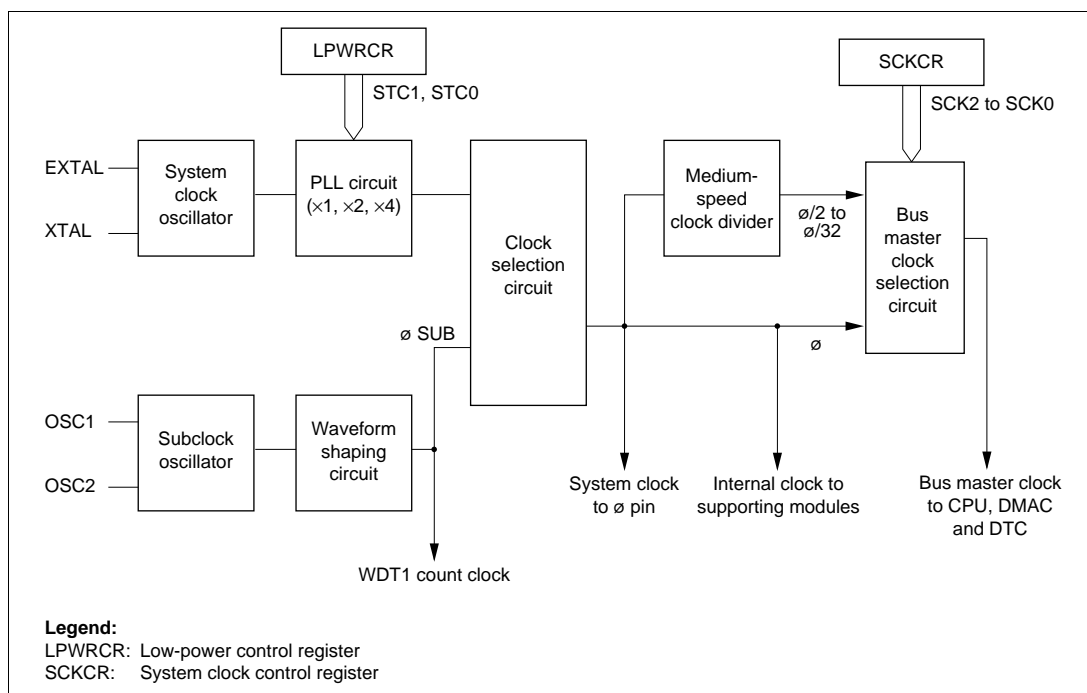
### 23A.1 Overview

The H8S/2633 Series has a built-in clock pulse generator (CPG) that generates the system clock ( $\phi$ ), the bus master clock, and internal clocks.

The clock pulse generator consists of an oscillator, PLL (phase-locked loop) circuit, clock selection circuit, medium-speed clock divider, bus master clock selection circuit, subclock oscillator, and waveform shaping circuit. The frequency can be changed by means of the PLL circuit in the CPG. Frequency changes are performed by software by means of settings in the system clock control register (SCKCR) and low-power control register (LPWRCR).

#### 23A.1.1 Block Diagram

Figure 23A-1 shows a block diagram of the clock pulse generator.



**Figure 23A-1 Block Diagram of Clock Pulse Generator**

### 23A.1.2 Register Configuration

The clock pulse generator is controlled by SCKCR and LPWRCR. Table 23A-1 shows the register configuration.

**Table 23A-1 Clock Pulse Generator Register**

Name	Abbreviation	R/W	Initial Value	Address*
System clock control register	SCKCR	R/W	H'00	H'FDE6
Low-power control register	LPWRCR	R/W	H'00	H'FDEC

Note:\* Lower 16 bits of the address.

## 23A.2 Register Descriptions

### 23A.2.1 System Clock Control Register (SCKCR)

Bit	:	7	6	5	4	3	2	1	0
		PSTOP	—	—	—	STCS	SCK2	SCK1	SCK0
Initial value:		0	0	0	0	0	0	0	0
R/W	:	R/W	—	—	—	R/W	R/W	R/W	R/W

SCKCR is an 8-bit readable/writable register that performs  $\phi$  clock output control, selection of operation when the PLL circuit frequency multiplication factor is changed, and medium-speed mode control.

SCKCR is initialized to H'00 by a reset and in hardware standby mode. It is not initialized in software standby mode.

**Bit 7— $\phi$  Clock Output Disable (PSTOP):** Controls  $\phi$  output.

Bit 7 PSTOP	Description			
	High-Speed Mode, Medium-Speed Mode, Sub-Active Mode	Sleep Mode Sub-Sleep Mode	Software Standby Mode, Watch Mode, Direct Transitions	Hardware Standby Mode
0	$\phi$ output (initial value)	$\phi$ output	Fixed high	High impedance
1	Fixed high	Fixed high	Fixed high	High impedance

**Bits 6 to 4—Reserved:** These bits are always read as 0 and cannot be modified.

**Bit 3—Frequency Multiplication Factor Switching Mode Select (STCS):** Selects the operation when the PLL circuit frequency multiplication factor is changed.

**Bit 3**

STCS	Description
0	Specified multiplication factor is valid after transition to software standby mode, watch mode, and subactive mode (Initial value)
1	Specified multiplication factor is valid immediately after STC bits are rewritten

**Bits 2 to 0—System Clock Select 2 to 0 (SCK2 to SCK0):** These bits select the bus master clock.

Bit 2	Bit 1	Bit 0	Description
0	0	0	Bus master is in high-speed mode (Initial value)
		1	Medium-speed clock is $\phi/2$
	1	0	Medium-speed clock is $\phi/4$
		1	Medium-speed clock is $\phi/8$
1	0	0	Medium-speed clock is $\phi/16$
		1	Medium-speed clock is $\phi/32$
	1	—	—
		—	—

**23A.2.2 Low-Power Control Register (LPWRCR)**

Bit	:	7	6	5	4	3	2	1	0
		DTON	LSON	NESEL	SUBSTP	RFCUT	—	STC1	STC0
Initial value	:	0	0	0	0	0	0	0	0
R/W	:	R/W	R/W	R/W	R/W	R/W	R/W	R/W	R/W

LPWRCR is an 8-bit readable/writable register that performs power-down mode control. The following pertains to bits 1 and 0. For details of the other bits, see section 24.2.3, Low-Power Control Register (LPWRCR). LPWRCR is initialized to H'00 by a reset and in hardware standby mode. It is not initialized in software standby mode.

**Bits 1 and 0—Frequency Multiplication Factor (STC1, STC0):** The STC bits specify the frequency multiplication factor of the PLL circuit.

Bit 1	Bit 0	
STC1	STC0	Description
0	0	×1 (Initial value)
	1	×2
1	0	×4
	1	Setting prohibited

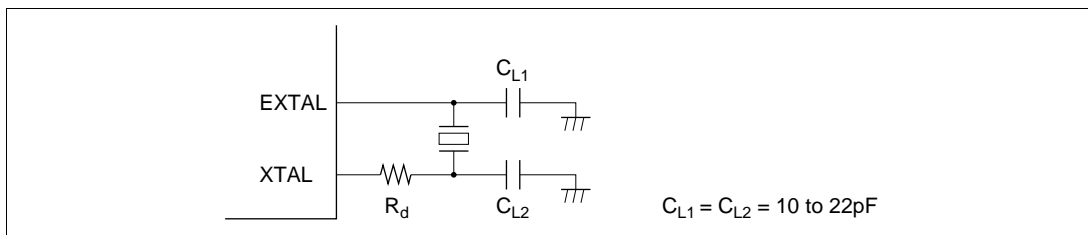
Note: A system clock frequency multiplied by the multiplication factor (STC1 and STC0) should not exceed the maximum operating frequency defined in section 25 Electrical Characteristics.

### 23A.3 Oscillator

Clock pulses can be supplied by connecting a crystal resonator, or by input of an external clock.

#### 23A.3.1 Connecting a Crystal Resonator

**Circuit Configuration:** A crystal resonator can be connected as shown in the example in figure 23A-2. Select the damping resistance  $R_d$  according to table 23A-2. An AT-cut parallel-resonance crystal should be used.



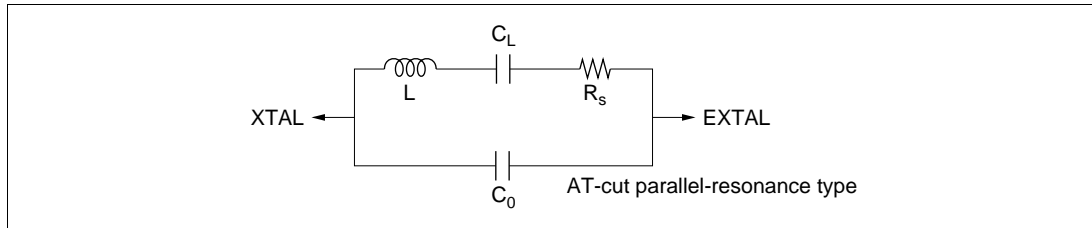
**Figure 23A-2 Connection of Crystal Resonator (Example)**

**Table 23A-2 Damping Resistance Value**

Frequency (MHz)	2	4	8	12	16	20	25
$R_d$ ( $\Omega$ )	1 k	500	200	0	0	0	0

**Crystal Resonator:** Figure 23A-3 shows the equivalent circuit of the crystal resonator. Use a crystal resonator that has the characteristics shown in table 23A-3.





**Figure 23A-3 Crystal Resonator Equivalent Circuit**

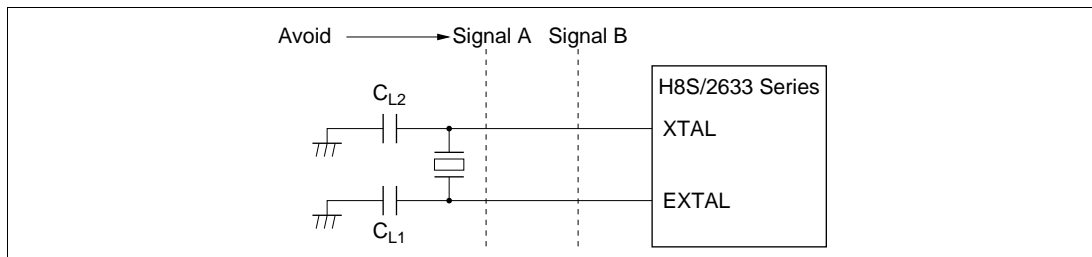
**Table 23A-3 Crystal Resonator Parameters**

Frequency (MHz)	2	4	8	12	16	20	25
$R_s$ max ( $\Omega$ )	500	120	80	60	50	40	40
$C_0$ max (pF)	7	7	7	7	7	7	7

**Note on Board Design:** When a crystal resonator is connected, the following points should be noted:

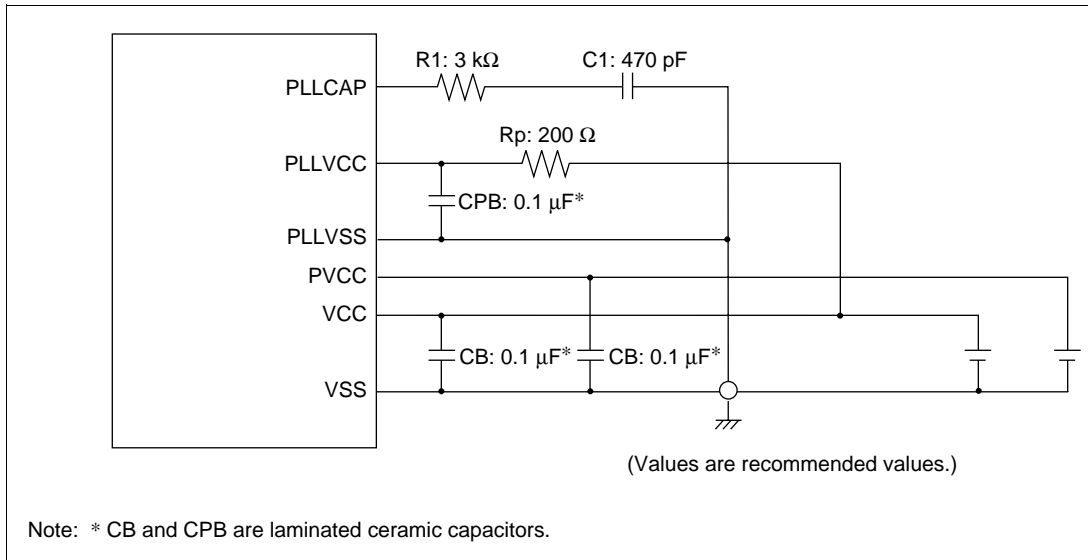
Other signal lines should be routed away from the oscillator circuit to prevent induction from interfering with correct oscillation. See figure 23A-4.

When designing the board, place the crystal resonator and its load capacitors as close as possible to the XTAL and EXTAL pins.



**Figure 23A-4 Example of Incorrect Board Design**

External circuitry such as that shown below is recommended around the PLL.



**Figure 23A-5 Points for Attention when Using PLL Oscillation Circuit**

Place oscillation stabilization capacitor C1 and resistor R1 close to the PLLCAP pin, and ensure that no other signal lines cross this line. Supply the C1 ground from PLLVSS.

Separate PLLVCC and PLLVSS from the other VCC and VSS lines at the board power supply source, and be sure to insert bypass capacitors CPB and CB close to the pins.

### 23A.3.2 External Clock Input

**Circuit Configuration:** An external clock signal can be input as shown in the examples in figure 23A-6. If the XTAL pin is left open, make sure that stray capacitance is no more than 10 pF.

In example (b), make sure that the external clock is held high in standby mode.

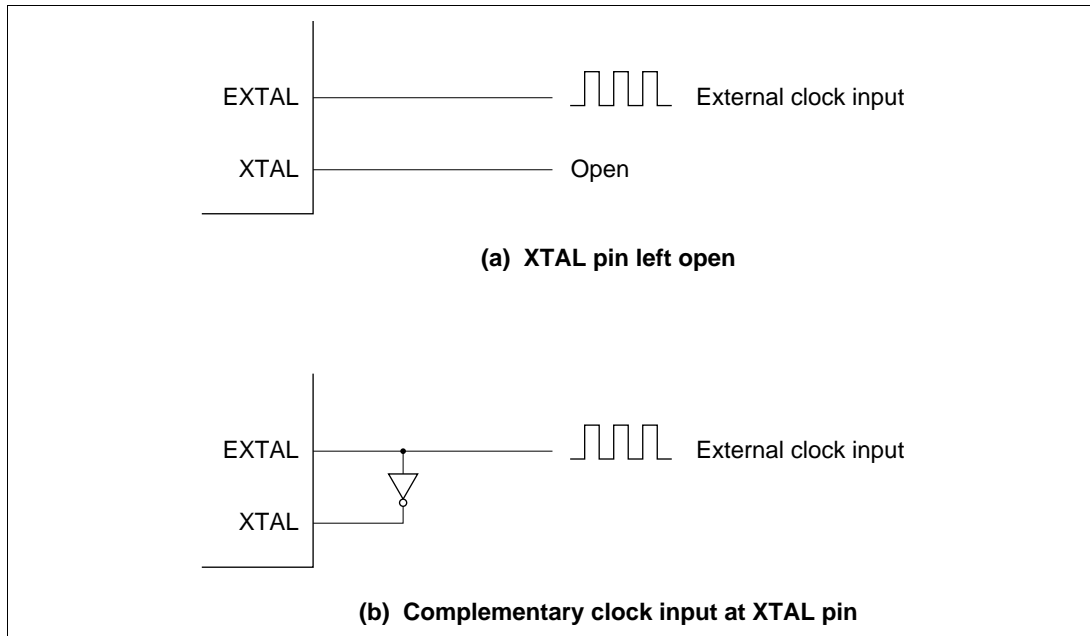


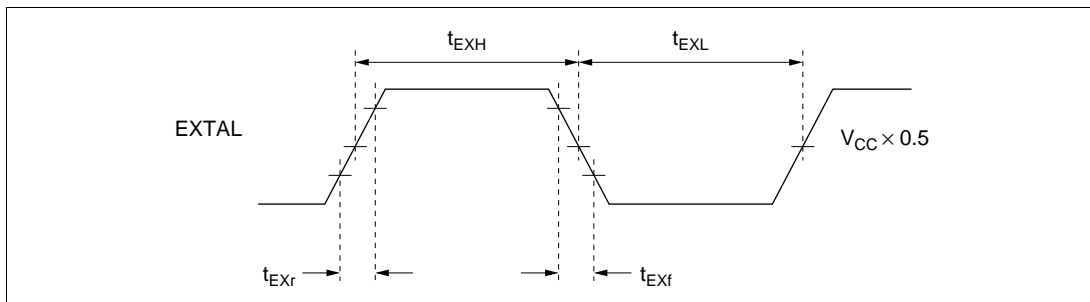
Figure 23A-6 External Clock Input (Examples)

## External Clock

Table 23A-4 and figure 23A-7 show the input conditions for the external clock.

**Table 23A-4 External Clock Input Conditions**

Item	Symbol	$V_{CC} = 3.0\text{ V}$ to $3.6\text{ V}$ , $PV_{CC} = 3.0\text{ V}$ to $5.5\text{ V}$		$V_{CC} = 3.0\text{ V}$ to $3.6\text{ V}$ , $PV_{CC} = 5.0\text{ V}$ $\pm 10\%$		Unit	Test Conditions
		Min	Max	Min	Max		
External clock input low pulse width	$t_{EXL}$	20	—	15	—	ns	Figure 23A-7
External clock input high pulse width	$t_{EXH}$	20	—	15	—	ns	
External clock rise time	$t_{EXr}$	—	10	—	5	ns	
External clock fall time	$t_{EXf}$	—	10	—	5	ns	
Clock low pulse width level	$t_{CL}$	0.4	0.6	0.4	0.6	$t_{cyc}$	$\phi \geq 5\text{ MHz}$ Figure 25-2
		80	—	80	—	ns	$\phi < 5\text{ MHz}$
Clock high pulse width level	$t_{CH}$	0.4	0.6	0.4	0.6	$t_{cyc}$	$\phi \geq 5\text{ MHz}$
		80	—	80	—	ns	$\phi < 5\text{ MHz}$



**Figure 23A-7 External Clock Input Timing**

## 23A.4 PLL Circuit

The PLL circuit has the function of multiplying the frequency of the clock from the oscillator by a factor of 1, 2, or 4. The multiplication factor is set with the STC bits in LPWRCR. The phase of the rising edge of the internal clock is controlled so as to match that at the EXTAL pin. When setting the multiplication factor, ensure that the clock frequency after multiplication does not exceed the maximum operating frequency of the chip.

When the multiplication factor of the PLL circuit is changed, the operation varies according to the setting of the STCS bit in SCKCR.

When STCS = 0 (initial value), the setting becomes valid after a transition to software standby mode, watch mode, or subactive mode. The transition time count is performed in accordance with the setting of bits STS2 to STS0 in SBYCR.

- [1] The initial PLL circuit multiplication factor is 1.
- [2] A value is set in bits STS2 to STS0 to give the specified transition time.
- [3] The target value is set in STC1 and STC0, and a transition is made to software standby mode, watch mode, or subactive mode.
- [4] The clock pulse generator stops and the value set in STC1 and STC0 becomes valid.
- [5] Software standby mode, watch mode, or subactive mode is cleared, and a transition time is secured in accordance with the setting in STS2 to STS0.
- [6] After the set transition time has elapsed, the LSI resumes operation using the target multiplication factor.

If a PC break is set for the SLEEP instruction that causes a transition to software standby mode in [3], software standby mode is entered and break exception handling is executed after the oscillation stabilization time. In this case, the instruction following the SLEEP instruction is executed after execution of the RTE instruction.

When STCS = 1, the LSI operates on the changed multiplication factor immediately after bits STC1 and STC0 are rewritten.

## 23A.5 Medium-Speed Clock Divider

The medium-speed clock divider divides the system clock to generate  $\phi/2$ ,  $\phi/4$ ,  $\phi/8$ ,  $\phi/16$ , and  $\phi/32$ .

## 23A.6 Bus Master Clock Selection Circuit

The bus master clock selection circuit selects the system clock ( $\phi$ ) or one of the medium-speed clocks ( $\phi/2$ ,  $\phi/4$ ,  $\phi/8$ ,  $\phi/16$ , and  $\phi/32$ ) to be supplied to the bus master, according to the settings of the SCK2 to SCK0 bits in SCKCR.

## 23A.7 Subclock Oscillator

### (1) Connecting 32.768kHz Quartz Resonator

To supply a clock to the subclock oscillator, connect a 32.768kHz quartz resonator, as shown in figure 23A-8. See section 23A.3.1, Notes on Board Design for notes on connecting crystal resonators.

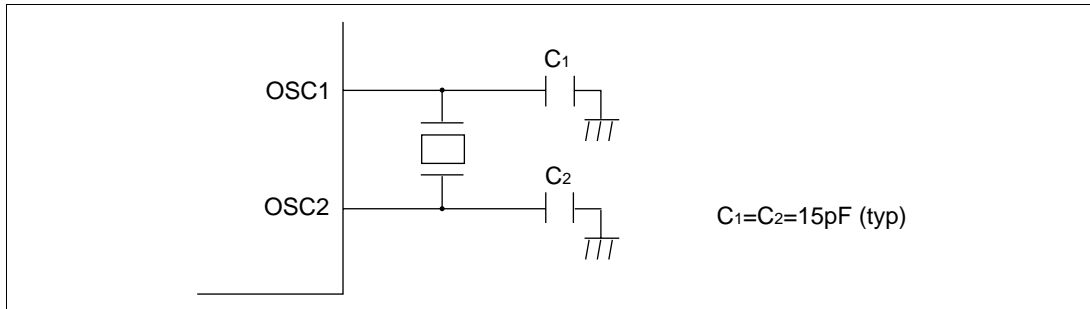


Figure 23A-8 Example Connection of 32.768kHz Crystal Resonator

Figure 23A-9 shows the equivalence circuit for a 32.768kHz resonator.

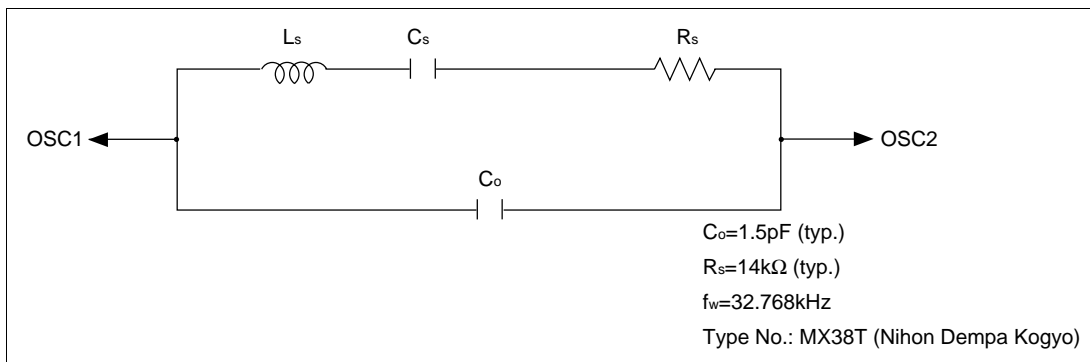


Figure 23A-9 Equivalence Circuit for 32.768kHz Resonator

## (2) Handling pins when subclock not required

If no subclock is required, connect the OSC1 pin to Vcc and leave OSC2 open, as shown in figure 23A-10.

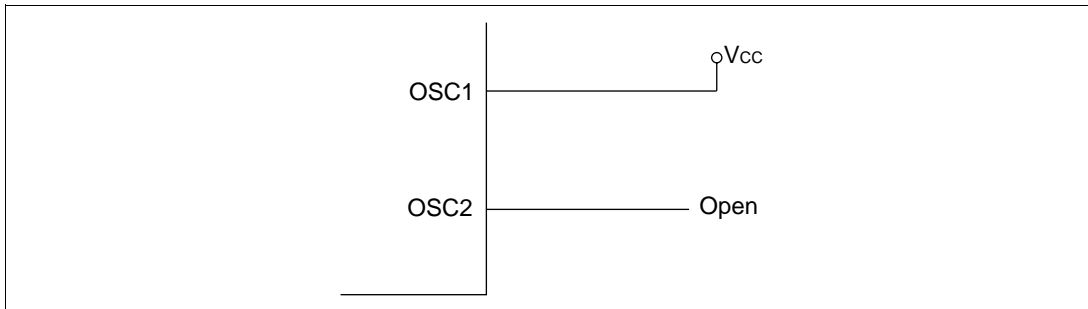


Figure 23A-10 Pin Handling When Subclock Not Required

### 23A.8 Subclock Waveform Shaping Circuit

To eliminate noise from the subclock input to OSC1, the subclock is sampled using the dividing clock  $\phi$ . The sampling frequency is set using the NESEL bit of LPWRCCR. For details, see section 24.2.3, Low-Power Control Register (LPWRCCR).

No sampling is performed in sub-active mode, sub-sleep mode, or watch mode.

### 23A.9 Note on Crystal Resonator

Since various characteristics related to the crystal resonator are closely linked to the user's board design, thorough evaluation is necessary on the user's part, for both the mask ROM versions and F-ZTAT versions, using the resonator connection examples shown in this section as a guide. As the resonator circuit ratings will depend on the floating capacitance of the resonator and the mounting circuit, the ratings should be determined in consultation with the resonator manufacturer. The design must ensure that a voltage exceeding the maximum rating is not applied to the oscillator pin.





# Section 23B Clock Pulse Generator (H8S/2633R, H8S/2695)

## 23B.1 Overview

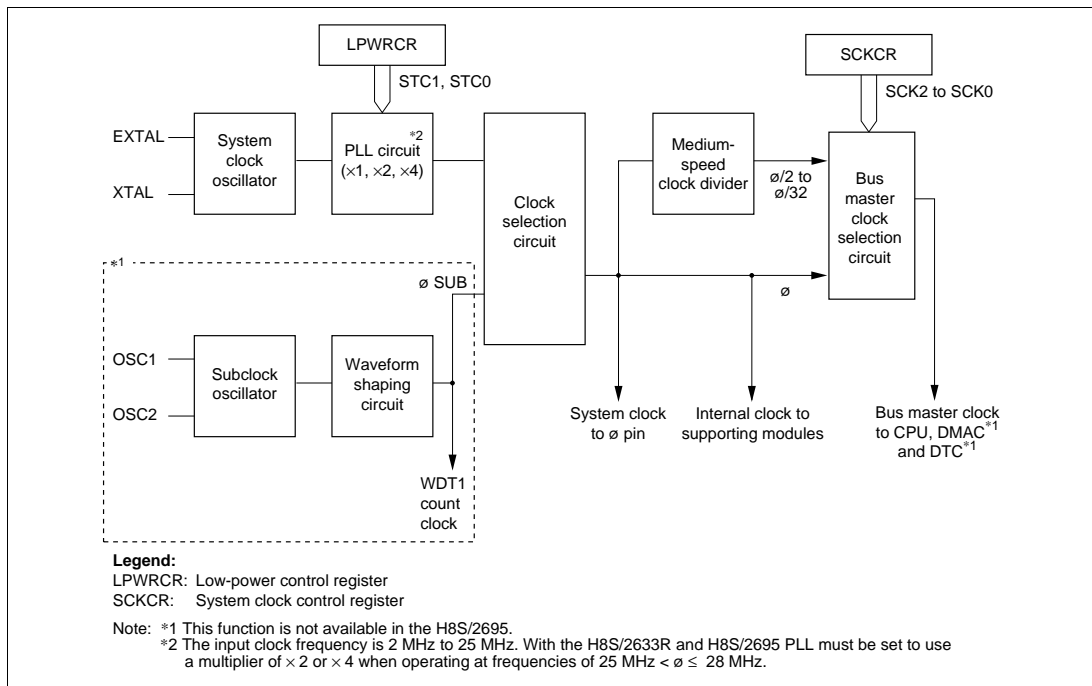
The H8S/2633R has a built-in clock pulse generator (CPG) that generates the system clock ( $\phi$ ), the bus master clock, and internal clocks.

The clock pulse generator consists of an oscillator, PLL (phase-locked loop) circuit, clock selection circuit, medium-speed clock divider, bus master clock selection circuit, subclock oscillator, and waveform shaping circuit. The frequency can be changed by means of the PLL circuit in the CPG. Frequency changes are performed by software by means of settings in the system clock control register (SCKCR) and low-power control register (LPWRCR).

The input clock frequency is 2 MHz to 25 MHz. With the H8S/2633R and H8S/2695 PLL must be set to use a multiplier of  $\times 2$  or  $\times 4$  when operating at frequencies of  $25 \text{ MHz} < \phi \leq 28 \text{ MHz}$ .

### 23B.1.1 Block Diagram

Figure 23B-1 shows a block diagram of the clock pulse generator.



**Figure 23B-1 Block Diagram of Clock Pulse Generator**

### 23B.1.2 Register Configuration

The clock pulse generator is controlled by SCKCR and LPWRCR. Table 23B-1 shows the register configuration.

**Table 23B-1 Clock Pulse Generator Register**

Name	Abbreviation	R/W	Initial Value	Address*
System clock control register	SCKCR	R/W	H'00	H'FDE6
Low-power control register	LPWRCR	R/W	H'00	H'FDEC

Note:\* Lower 16 bits of the address.

## 23B.2 Register Descriptions

### 23B.2.1 System Clock Control Register (SCKCR)

Bit	:	7	6	5	4	3	2	1	0
		PSTOP	—	—	—	STCS	SCK2	SCK1	SCK0
Initial value:		0	0	0	0	0	0	0	0
R/W	:	R/W	—	—	—	R/W	R/W	R/W	R/W

SCKCR is an 8-bit readable/writable register that performs  $\phi$  clock output control, selection of operation when the PLL circuit frequency multiplication factor is changed, and medium-speed mode control.

SCKCR is initialized to H'00 by a reset and in hardware standby mode. It is not initialized in software standby mode.

**Bit 7— $\phi$  Clock Output Disable (PSTOP):** Controls  $\phi$  output.

Description				
Bit 7	High-Speed Mode, Medium-Speed Mode, Sub-Active Mode	Sleep Mode Sub-Sleep Mode	Software Standby Mode, Watch Mode*, Direct Transitions*	Hardware Standby Mode
PSTOP				
0	$\phi$ output (initial value)	$\phi$ output	Fixed high	High impedance
1	Fixed high	Fixed high	Fixed high	High impedance

Note: \* This function is not available in the H8S/2695.

**Bits 6 to 4—Reserved:** These bits are always read as 0 and cannot be modified.

**Bit 3—Frequency Multiplication Factor Switching Mode Select (STCS):** Selects the operation when the PLL circuit frequency multiplication factor is changed.

**Bit 3**

STCS	Description
0	Specified multiplication factor is valid after transition to software standby mode, watch mode, and subactive mode (Initial value)
1	Specified multiplication factor is valid immediately after STC bits are rewritten

**Bits 2 to 0—System Clock Select 2 to 0 (SCK2 to SCK0):** These bits select the bus master clock.

Bit 2	Bit 1	Bit 0	Description
0	0	0	Bus master is in high-speed mode (Initial value)
		1	Medium-speed clock is $\phi/2$
	1	0	Medium-speed clock is $\phi/4$
		1	Medium-speed clock is $\phi/8$
1	0	0	Medium-speed clock is $\phi/16$
		1	Medium-speed clock is $\phi/32$
	1	—	—
		—	—

### 23B.2.2 Low-Power Control Register (LPWRCR)

**H8S/2633R**

Bit	:	7	6	5	4	3	2	1	0
		DTON	LSON	NESEL	SUBSTP	RFCUT	—	STC1	STC0
Initial value	:	0	0	0	0	0	0	0	0
R/W	:	R/W	R/W	R/W	R/W	R/W	R/W	R/W	R/W

**H8S/2695**

Bit	:	7	6	5	4	3	2	1	0
		—*	—*	—*	—*	—*	—	STC1	STC0
Initial value	:	0	0	0	0	0	0	0	0
R/W	:	R	R	R/W	R/W	R/W	R/W	R/W	R/W

Note: \* On the H8S/2695 only 0 should be written to these bits.

LPWRCCR is an 8-bit readable/writable register that performs power-down mode control. The following pertains to bits 1 and 0. For details of the other bits, see section 24.2.3, Low-Power Control Register (LPWRCCR). LPWRCCR is initialized to H'00 by a reset and in hardware standby mode. It is not initialized in software standby mode.

**Bits 1 and 0—Frequency Multiplication Factor (STC1, STC0):** The STC bits specify the frequency multiplication factor of the PLL circuit.

Bit 1	Bit 0	Description
STC1	STC0	
0	0	×1 (Initial value)
	1	×2
1	0	×4
	1	Setting prohibited

Note: A system clock frequency multiplied by the multiplication factor (STC1 and STC0) should not exceed the maximum operating frequency defined in section 26 and 27, Electrical Characteristics.

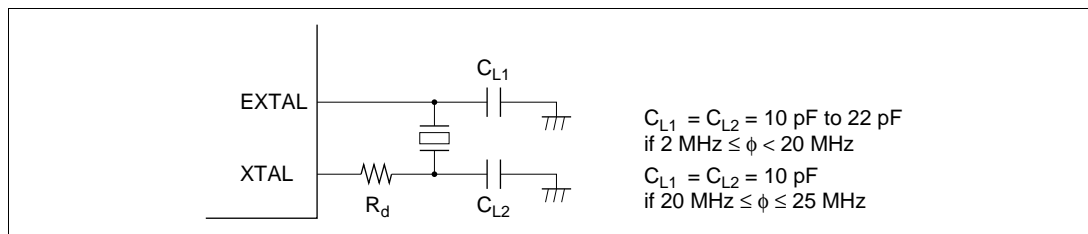
The input clock frequency is 2 MHz to 25 MHz. With the H8S/2633R and H8S/2695 PLL must be set to use a multiplier of ×2 or ×4 when operating at frequencies of  $25 \text{ MHz} < \phi \leq 28 \text{ MHz}$ .

### 23B.3 Oscillator

Clock pulses can be supplied by connecting a crystal resonator, or by input of an external clock.

#### 23B.3.1 Connecting a Crystal Resonator

**Circuit Configuration:** A crystal resonator can be connected as shown in the example in figure 23B-2. Select the damping resistance  $R_d$  according to table 23B-2. An AT-cut parallel-resonance crystal should be used.

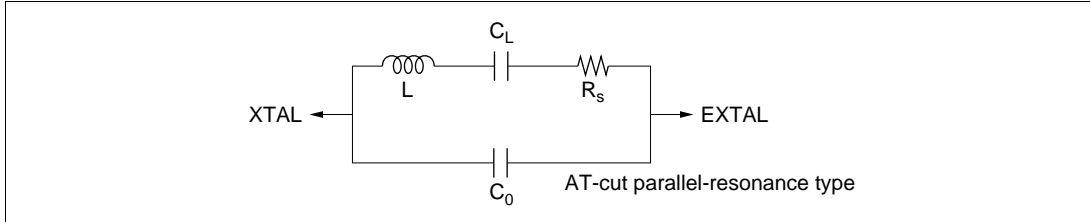


**Figure 23B-2 Connection of Crystal Resonator (Example)**

**Table 23B-2 Damping Resistance Value**

Frequency (MHz)	2	4	8	12	16	20	25
$R_d$ ( $\Omega$ )	1 k	500	200	0	0	0	0

**Crystal Resonator:** Figure 23B-3 shows the equivalent circuit of the crystal resonator. Use a crystal resonator that has the characteristics shown in table 23B-3.



**Figure 23B-3 Crystal Resonator Equivalent Circuit**

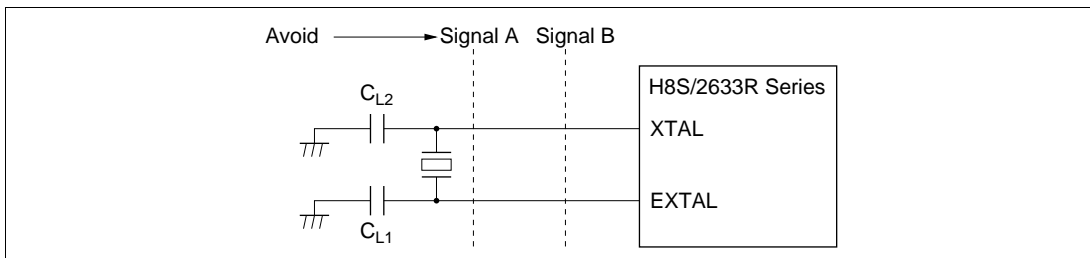
**Table 23B-3 Crystal Resonator Parameters**

Frequency (MHz)	2	4	8	12	16	20	25
$R_s$ max ( $\Omega$ )	500	120	80	60	50	40	40
$C_0$ max (pF)	7	7	7	7	7	7	7

**Note on Board Design:** When a crystal resonator is connected, the following points should be noted:

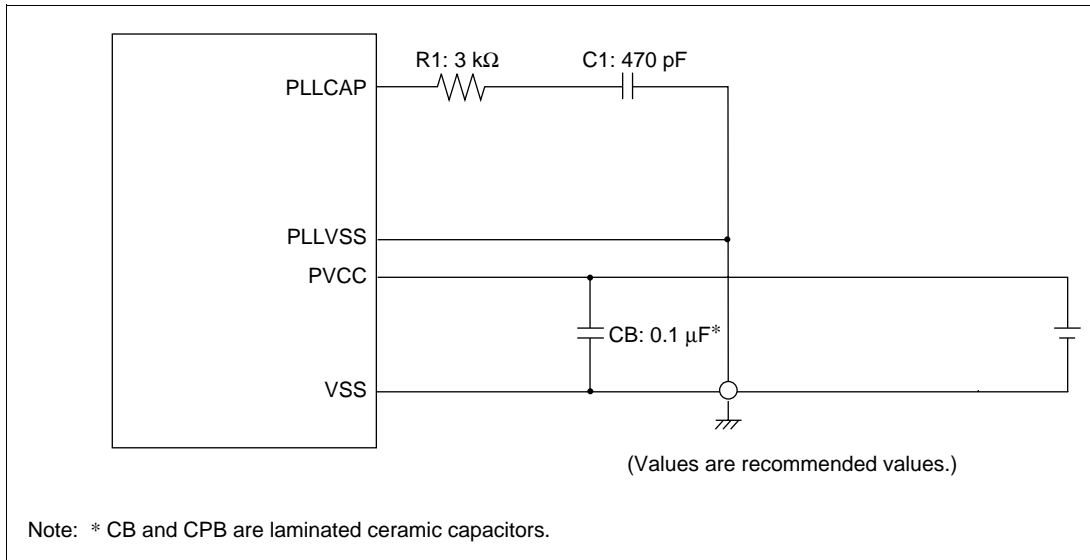
Other signal lines should be routed away from the oscillator circuit to prevent induction from interfering with correct oscillation. See figure 23B-4.

When designing the board, place the crystal resonator and its load capacitors as close as possible to the XTAL and EXTAL pins.



**Figure 23B-4 Example of Incorrect Board Design**

External circuitry such as that shown below is recommended around the PLL.



**Figure 23B-5 Points for Attention when Using PLL Oscillation Circuit**

Place oscillation stabilization capacitor C1 and resistor R1 close to the PLLCAP pin, and ensure that no other signal lines cross this line. Supply the C1 ground from PLLVSS.

Separate PLLVSS from the other VCC and VSS lines at the board power supply source, and be sure to insert bypass capacitors CPB and CB close to the pins.

### 23B.3.2 External Clock Input

**Circuit Configuration:** An external clock signal can be input as shown in the examples in figure 23B-6. If the XTAL pin is left open, make sure that stray capacitance is no more than 10 pF.

In example (b), make sure that the external clock is held high in standby mode.

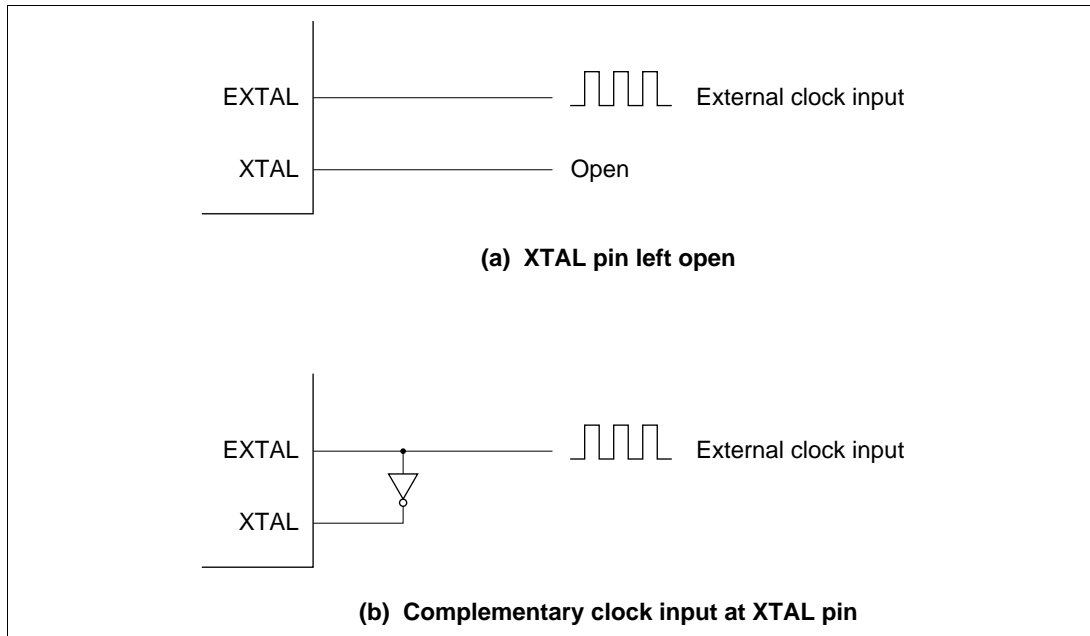


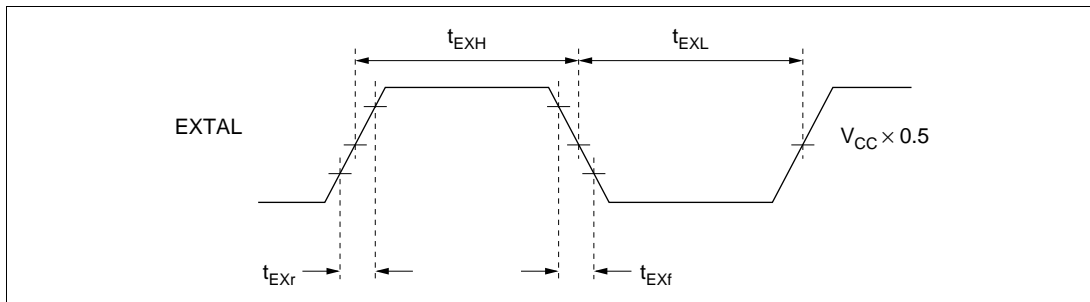
Figure 23B-6 External Clock Input (Examples)

## External Clock

Table 23B-4 and figure 23B-7 show the input conditions for the external clock.

**Table 23B-4 External Clock Input Conditions**

Item	Symbol	$PV_{CC} = 5.0\text{ V} \pm 10\%$		Unit	Test Conditions
		Min	Max		
External clock input low pulse width	$t_{EXL}$	15	—	ns	Figure 23B-7
External clock input high pulse width	$t_{EXH}$	15	—	ns	
External clock rise time	$t_{EXr}$	—	5	ns	
External clock fall time	$t_{EXf}$	—	5	ns	
Clock low pulse width level	$t_{CL}$	0.4	0.6	$t_{cyc}$	$\emptyset \geq 5\text{ MHz}$
		80	—	ns	$\emptyset < 5\text{ MHz}$
Clock high pulse width level	$t_{CH}$	0.4	0.6	$t_{cyc}$	$\emptyset \geq 5\text{ MHz}$
		80	—	ns	$\emptyset < 5\text{ MHz}$



**Figure 23B-7 External Clock Input Timing**



## 23B.4 PLL Circuit

The PLL circuit has the function of multiplying the frequency of the clock from the oscillator by a factor of 1, 2, or 4. The multiplication factor is set with the STC bits in LPWRCR. The phase of the rising edge of the internal clock is controlled so as to match that at the EXTAL pin. When setting the multiplication factor, ensure that the clock frequency after multiplication does not exceed the maximum operating frequency of the chip.

When the multiplication factor of the PLL circuit is changed, the operation varies according to the setting of the STCS bit in SCKCR.

When STCS = 0 (initial value), the setting becomes valid after a transition to software standby mode, watch mode, or subactive mode. The transition time count is performed in accordance with the setting of bits STS2 to STS0 in SBYCR.

- [1] The initial PLL circuit multiplication factor is 1. (The upper limit for the input clock is 25 MHz. In order to use an operating frequency higher than 25 MHz a multiplication ratio of  $\times 2$  or  $\times 4$  must be employed.)
- [2] A value is set in bits STS2 to STS0 to give the specified transition time.
- [3] The target value is set in STC1 and STC0, and a transition is made to software standby mode, watch mode, or subactive mode.
- [4] The clock pulse generator stops and the value set in STC1 and STC0 becomes valid.
- [5] Software standby mode, watch mode, or subactive mode is cleared, and a transition time is secured in accordance with the setting in STS2 to STS0.
- [6] After the set transition time has elapsed, the LSI resumes operation using the target multiplication factor.

If a PC break is set for the SLEEP instruction that causes a transition to software standby mode in [3], software standby mode is entered and break exception handling is executed after the oscillation stabilization time. In this case, the instruction following the SLEEP instruction is executed after execution of the RTE instruction.

When STCS = 1, the LSI operates on the changed multiplication factor immediately after bits STC1 and STC0 are rewritten.

## 23B.5 Medium-Speed Clock Divider

The medium-speed clock divider divides the system clock to generate  $\phi/2$ ,  $\phi/4$ ,  $\phi/8$ ,  $\phi/16$ , and  $\phi/32$ .

## 23B.6 Bus Master Clock Selection Circuit

The bus master clock selection circuit selects the system clock ( $\phi$ ) or one of the medium-speed clocks ( $\phi/2$ ,  $\phi/4$ ,  $\phi/8$ ,  $\phi/16$ , and  $\phi/32$ ) to be supplied to the bus master, according to the settings of the SCK2 to SCK0 bits in SCKCR.

## 23B.7 Subclock Oscillator (This function is not available in the H8S/2695)

### (1) Connecting 32.768kHz Quartz Resonator

To supply a clock to the subclock oscillator, connect a 32.768kHz quartz resonator, as shown in figure 23B-8. See section 23B.3.1, Notes on Board Design for notes on connecting crystal resonators.

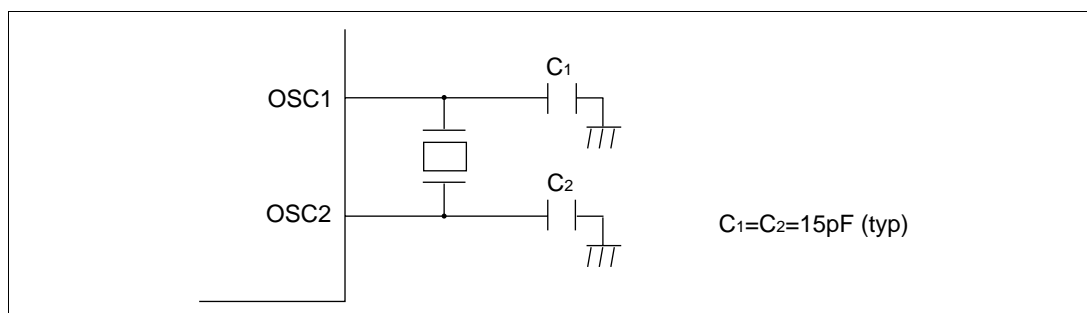


Figure 23B-8 Example Connection of 32.768kHz Crystal Resonator

Figure 23B-9 shows the equivalence circuit for a 32.768kHz resonator.

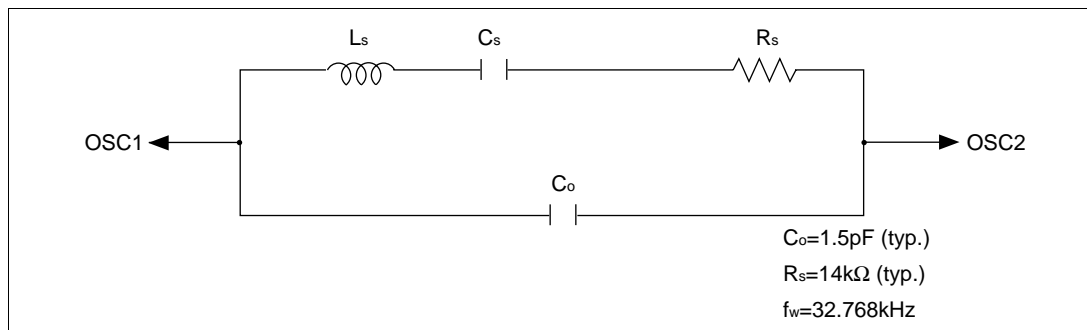
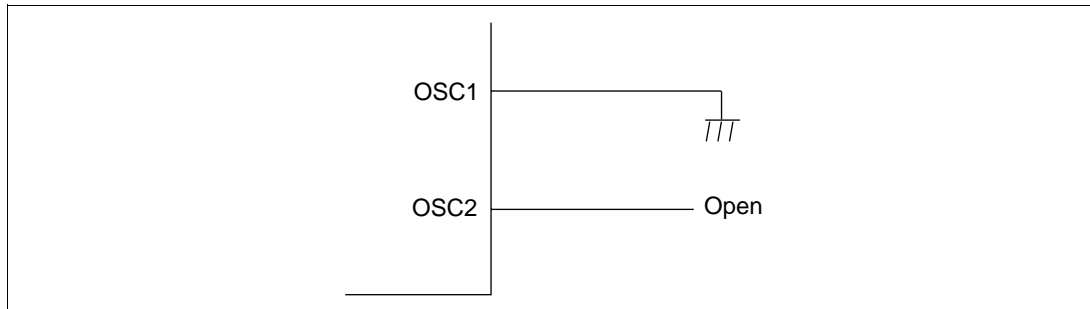


Figure 23B-9 Equivalence Circuit for 32.768kHz Resonator

## (2) Handling pins when subclock not required

If no subclock is required, connect the OSC1 pin to V<sub>ss</sub> and leave OSC2 open, as shown in figure 23B-10.



**Figure 23B-10 Pin Handling When Subclock Not Required**

Note: The H8S/2695 is not equipped with a subclock function. The pins corresponding to OSC1 and OSC2 are NC pins.

### 23B.8 Subclock Waveform Shaping Circuit

To eliminate noise from the subclock input to OSC1, the subclock is sampled using the dividing clock  $\phi$ . The sampling frequency is set using the NESEL bit of LPWRCCR. For details, see section 24.2.3, Low-Power Control Register (LPWRCCR).

No sampling is performed in sub-active mode, sub-sleep mode, or watch mode.

### 23B.9 Note on Crystal Resonator

Since various characteristics related to the crystal resonator are closely linked to the user's board design, thorough evaluation is necessary on the user's part, for both the mask ROM versions and F-ZTAT versions, using the resonator connection examples shown in this section as a guide. As the resonator circuit ratings will depend on the floating capacitance of the resonator and the mounting circuit, the ratings should be determined in consultation with the resonator manufacturer. The design must ensure that a voltage exceeding the maximum rating is not applied to the oscillator pin.



## Section 24 Power-Down Modes

### 24.1 Overview

In addition to the normal program execution state, the H8S/2633 Series has eight power-down modes in which operation of the CPU and oscillator is halted and power dissipation is reduced. Low-power operation can be achieved by individually controlling the CPU, on-chip supporting modules, and so on.

The H8S/2633 Series operating modes are as follows:

- (1) High-speed mode
- (2) Medium-speed mode
- (3) Subactive mode\*
- (4) Sleep mode
- (5) Subsleep mode\*
- (6) Watch mode\*
- (7) Module stop mode
- (8) Software standby mode
- (9) Hardware standby mode

(2) to (9) are power down modes. Sleep mode and sub-sleep mode are CPU mode, medium-speed mode is a CPU and bus master mode, sub-active mode is a CPU and bus master and on-chip supporting module mode, and module stop mode is an on-chip supporting module mode (including bus masters other than the CPU) state. Some of these modes can be combined.

After a reset, the LSI is in high-speed mode, with modules other than the DMAC and DTC in module stop mode.

Table 24-1 shows the internal states of the LSI in the respective modes. Table 24-2 shows the conditions for shifting between the power-down modes.

Figure 24-1 is a mode transition diagram.

Note: \* This function is not available in the H8S/2695.

**Table 24-1 LSI Internal States in Each Mode**

Function	High-Speed	Medium-Speed	Sleep	Module Stop <sup>*3</sup>	Watch	Sub-active	Subsleep	Software Standby	Hardware Standby	
System clock pulse generator	Functioning	Functioning	Functioning	Functioning	Halted	Halted	Halted	Halted	Halted	
Subclock pulse generator	Functioning	Functioning	Functioning	Functioning	Functioning	Functioning	Functioning	Functioning	Halted	
CPU	Instructions Registers	Functioning	Medium-speed operation	Halted <sup>*1</sup> (retained)	High/medium-speed operation	Halted <sup>*1</sup> (retained)	Subclock operation	Halted <sup>*1</sup> (retained)	Halted <sup>*1</sup> (retained)	Halted (undefined)
External interrupts	NMI IRQ0-IRQ7	Functioning	Functioning	Functioning	Functioning	Functioning	Functioning	Functioning	Functioning	Halted
Peripheral functions	WDT1 <sup>*4</sup>	Functioning	Functioning	Functioning	Functioning	Subclock operation	Subclock operation	Subclock operation	Halted <sup>*1</sup> (retained)	Halted <sup>*2</sup> (reset)
	WDT0	Functioning	Functioning	Functioning	Functioning	Halted <sup>*1</sup> (retained)	Subclock operation	Subclock operation	Halted <sup>*1</sup> (retained)	Halted <sup>*2</sup> (reset)
	TMR <sup>*4</sup>				Halted <sup>*1</sup> (retained)					
	DMAC <sup>*4</sup>	Functioning	Medium-speed operation	Functioning	Halted <sup>*1</sup> (retained)	Halted <sup>*1</sup> (retained)	Halted <sup>*1</sup> (retained)	Halted <sup>*1</sup> (retained)	Halted <sup>*1</sup> (retained)	Halted <sup>*2</sup> (reset)
	DTC <sup>*4</sup>									
	TPU	Functioning	Functioning	Functioning	Halted <sup>*1</sup> (retained)	Halted <sup>*1</sup> (retained)	Halted <sup>*1</sup> (retained)	Halted <sup>*1</sup> (retained)	Halted <sup>*1</sup> (retained)	Halted <sup>*2</sup> (reset)
	IIC0 <sup>*4</sup> IIC1 <sup>*4</sup> PCB <sup>*4</sup> PPG <sup>*4</sup> D/A0, 1 <sup>*4</sup>									
SCI0	Functioning	Functioning	Functioning	Halted <sup>*2</sup> (reset)	Halted <sup>*2</sup> (reset)	Halted <sup>*2</sup> (reset)	Halted <sup>*2</sup> (reset)	Halted <sup>*2</sup> (reset)	Halted <sup>*2</sup> (reset)	
SCI1										
SCI2										
SCI3										
SCI4										
PWM0, 1 <sup>*4</sup>										
A/D										
RAM	Functioning	Functioning	Functioning (DTC) <sup>*5</sup>	Functioning	Retained	Functioning	Retained	Retained	Retained	
I/O	Functioning	Functioning	Functioning	Functioning	Retained	Functioning <sup>*6</sup>	Retained	Retained	High impedance	

Notes: \*1 "Halted (retained)" means that internal register values are retained. The internal state is "operation suspended."

\*2 "Halted (reset)" means that internal register values and internal states are initialized.

\*3 In module stop mode, only modules for which a stop setting has been made are halted (reset or retained).

\*4 This function is not available in the H8S/2695.

\*5 Internal register values are retained because the H8S/2695 does not have a DTC.

\*6 With the exception of ports D and E, an I/O port always returns a value of 1 when read in the H8S/2633 F-ZTAT. Use as an output port is possible.

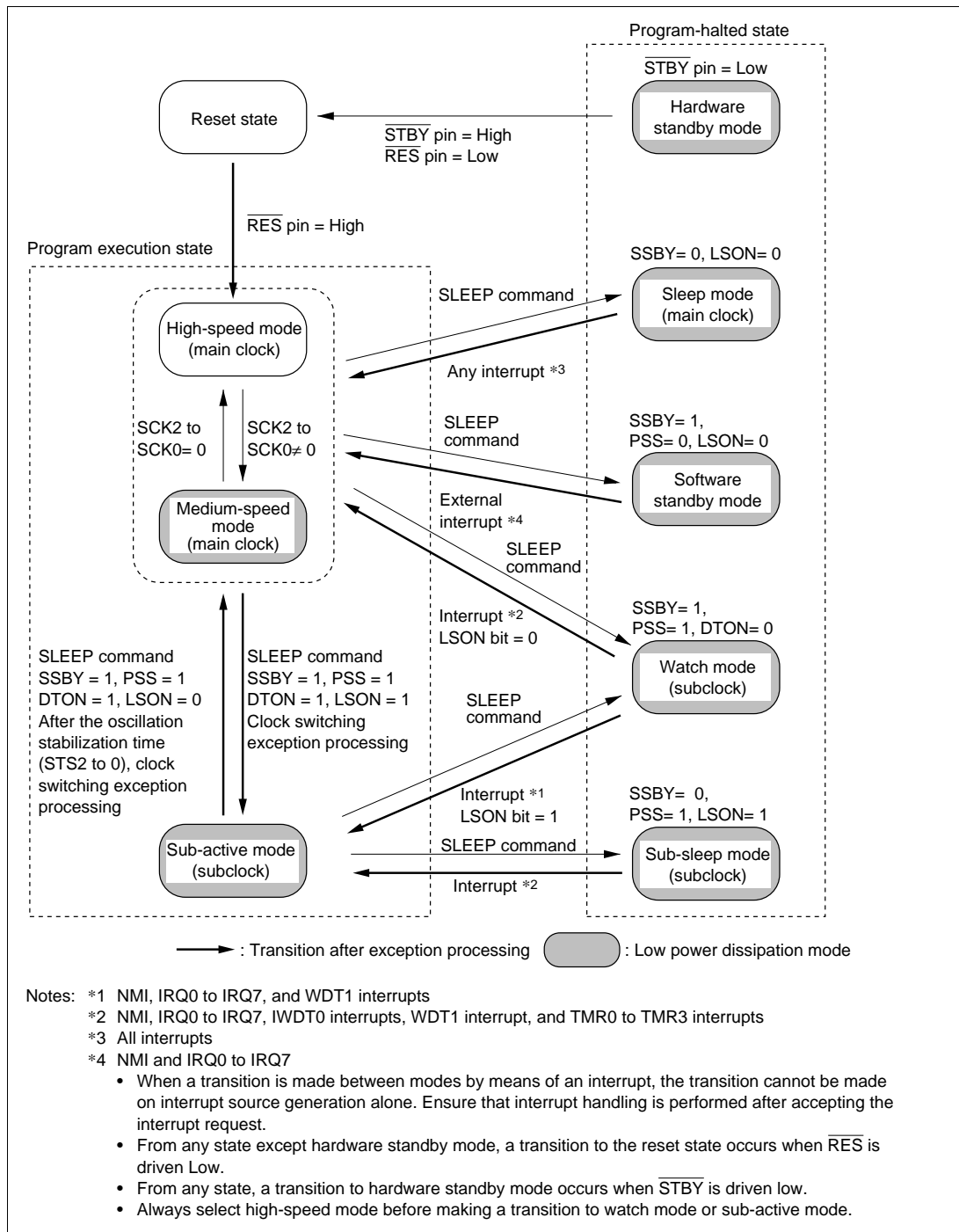
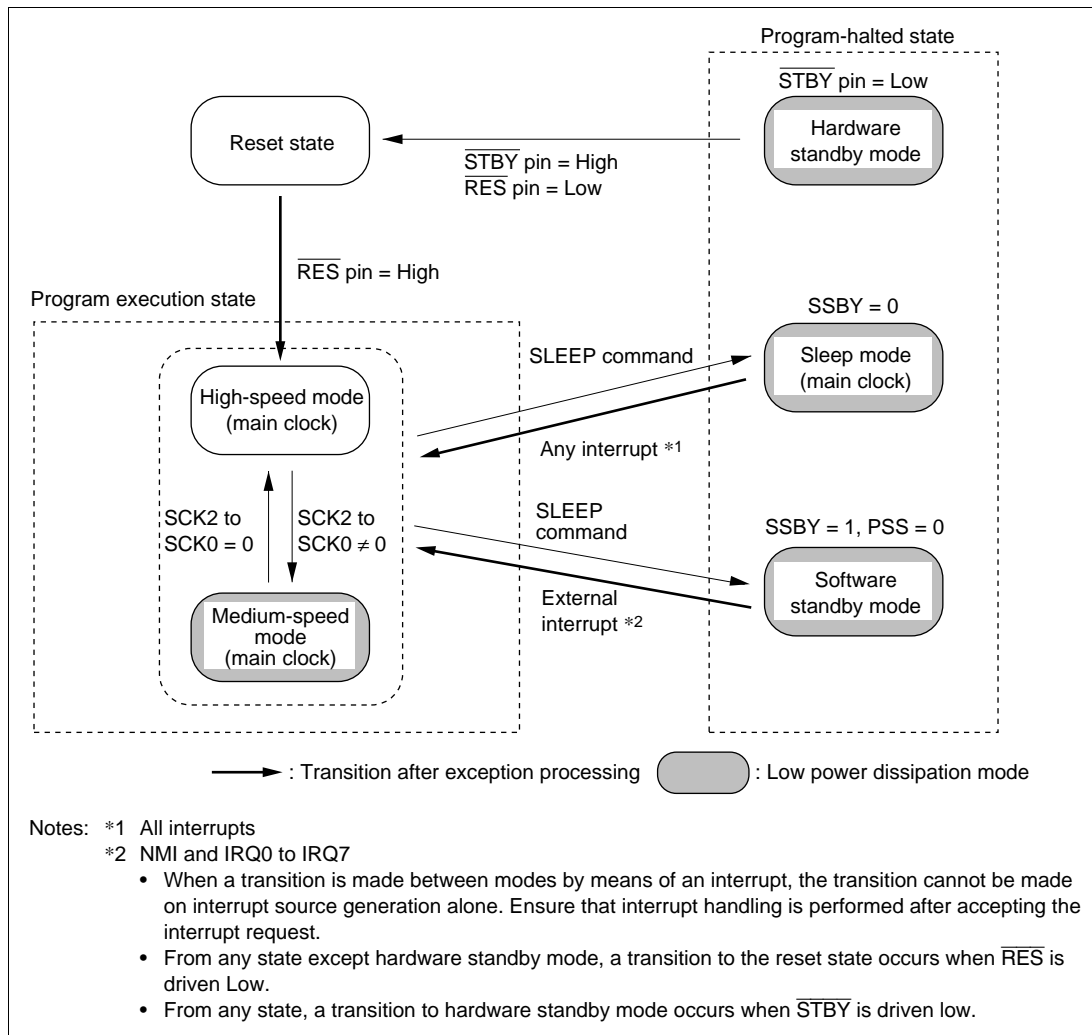


Figure 24-1(a) Mode Transition Diagram (H8S/2633 Series, H8S/2633R)



**Figure 24-1(b) Mode Transition Diagram (H8S/2695)**



**Table 24.2(a) Power-Down Mode Transition Conditions (H8S/2633 Series, H8S/2633R)**

Pre-Transition State	Status of Control Bit at Transition				State After Transition Invoked by SLEEP Command	State After Transition Back from Low Power Mode Invoked by Interrupt
	SSBY	PSS	LSON	DTON		
High-speed/ medium-speed	0	*	0	*	Sleep	High-speed/medium-speed
	0	*	1	*	—	—
	1	0	0	*	Software standby	High-speed/medium-speed
	1	0	1	*	—	—
	1	1	0	0	Watch	High-speed
	1	1	1	0	Watch	Sub-active
	1	1	0	1	—	—
	1	1	1	1	Sub-active	—
Sub-active	0	0	*	*	—	—
	0	1	0	*	—	—
	0	1	1	*	Sub-sleep	Sub-active
	1	0	*	*	—	—
	1	1	0	0	Watch	High-speed
	1	1	1	0	Watch	Sub-active
	1	1	0	1	High-speed	—
	1	1	1	1	—	—

\* : Don't care

—: Do not set

**Table 24.2(b) Power-Down Mode Transition Conditions (H8S/2695)**

State before Transition	Control Bit (SSBY) Status at Transition	State after Transition Using SLEEP Instruction	State after Return Using Interrupt
High-speed/ medium-speed	0	Sleep	High-speed/ medium-speed
	1	Software standby	High-speed/ medium-speed

### 24.1.1 Register Configuration

Power-down modes are controlled by the SBYCR, SCKCR, LPWRCR, TCSR (WDT1\*), and MSTPCR registers. Table 24-3 summarizes these registers.

Note: \* WDT1 is not available in the H8S/2695.

**Table 24-3 Power-Down Mode Registers**

<b>Name</b>	<b>Abbreviation</b>	<b>R/W</b>	<b>Initial Value</b>	<b>Address*<sup>1</sup></b>
Standby control register	SBYCR	R/W	H'08	H'FDE4
System clock control register	SCKCR	R/W	H'00	H'FDE6
Low-power control register	LPWRCR	R/W	H'00	H'FDEC
Timer control/status register (WDT1)* <sup>2</sup>	TCSR	R/W	H'00	H'FFA2
Module stop control register A, B, C	MSTPCRA	R/W	H'3F	H'FDE8
	MSTPCRB	R/W	H'FF	H'FDE9
	MSTPCRC	R/W	H'FF	H'FDEA

Notes: \*1 Lower 16 bits of the address.

\*2 WDT1 is not available in the H8S/2695.

## 24.2 Register Descriptions

### 24.2.1 Standby Control Register (SBYCR)

Bit	:	7	6	5	4	3	2	1	0
		SSBY	STS2	STS1	STS0	OPE	—	—	—
Initial value	:	0	0	0	0	1	0	0	0
R/W	:	R/W	R/W	R/W	R/W	R/W	—	—	—

SBYCR is an 8-bit readable/writable register that performs power-down mode control.

SBYCR is initialized to H'08 by a reset and in hardware standby mode. It is not initialized in software standby mode.

**Bit 7—Software Standby (SSBY):** When making a low power dissipation mode transition by executing the SLEEP instruction, the operating mode is determined in combination with other control bits.

Note that the value of the SSBY bit does not change even when shifting between modes using interrupts.

#### Bit 7

SSBY	Description
0	Shifts to sleep mode when the SLEEP instruction is executed in high-speed mode or medium-speed mode. Shifts to sub-sleep mode* when the SLEEP instruction is executed in sub-active mode*. (Initial value)
1	Shifts to software standby mode, sub-active mode*, and watch mode* when the SLEEP instruction is executed in high-speed mode or medium-speed mode. Shifts to watch mode* or high-speed mode when the SLEEP instruction is executed in sub-active mode*.

Note: \* This function is not available in the H8S/2695.

**Bits 6 to 4—Standby Timer Select 2 to 0 (STS2 to STS0):** These bits select the MCU wait time for clock stabilization when shifting to high-speed mode or medium-speed mode by using a specific interrupt or command to cancel software standby mode, watch mode\*, or sub-active mode\*. With a crystal oscillator (table 24-5), select a wait time of 8 ms (oscillation stabilization time) or more, depending on the operating frequency. With an external clock, select a wait time of 2 ms (PLL oscillator stabilization time) or more, depending on the operating frequency.

Note: \* This function is not available in the H8S/2695.

Bit 6	Bit 5	Bit 4	Description
STS2	STS1	STS0	
0	0	0	Standby time = 8192 states (Initial value)
		1	Standby time = 16384 states
	1	0	Standby time = 32768 states
		1	Standby time = 65536 states
1	0	0	Standby time = 131072 states
		1	Standby time = 262144 states
	1	0	Reserved
		1	Standby time = 16 states (Setting prohibited)

**Bit 3—Output Port Enable (OPE):** This bit specifies whether the output of the address bus and bus control signals ( $\overline{CS0}$  to  $\overline{CS7}$ ,  $\overline{AS}$ ,  $\overline{RD}$ ,  $\overline{HWR}$ ,  $\overline{LWR}$ ,  $\overline{CAS}$ , and  $\overline{OE}$ ) is retained or set to high-impedance state in the software standby mode, watch mode, and when making a direct transition.

Bit 3	Description
OPE	
0	In software standby mode, watch mode*, and when making a direct transition*, address bus and bus control signals are high-impedance.
1	In software standby mode, watch mode*, and when making a direct transition*, the output state of the address bus and bus control signals is retained. (Initial value)

Note: \* This function is not available in the H8S/2695.

**Bits 2 to 0—Reserved:** These bits are always read as 0 and cannot be modified.

## 24.2.2 System Clock Control Register (SCKCR)

Bit	:	7	6	5	4	3	2	1	0
		PSTOP	—	—	—	STCS	SCK2	SCK1	SCK0
Initial value	:	0	0	0	0	0	0	0	0
R/W	:	R/W	—	—	—	R/W	R/W	R/W	R/W

SCKCR is an 8-bit readable/writable register that performs  $\phi$  clock output control, selection of operation when the PLL circuit frequency multiplication factor is changed, and medium-speed mode control.

SCKCR is initialized to H'00 by a reset and in hardware standby mode. It is not initialized in software standby mode.

**Bit 7— $\phi$  Clock Output Disable (PSTOP):** In combination with the DDR of the applicable port, this bit controls  $\phi$  output. See section 24.12,  $\phi$  Clock Output Disabling Function, for details.

Description				
Bit 7	High-Speed Mode, Medium-Speed Mode, Sub-Active Mode*	Sleep Mode, Sub-Sleep Mode*	Software Standby Mode, Watch Mode*, Direct Transition	Hardware Standby Mode
0	$\phi$ output (initial value)	$\phi$ output	Fixed high	High impedance
1	Fixed high	Fixed high	Fixed high	High impedance

Note: \* This function is not available in the H8S/2695.

**Bits 6 to 4—Reserved:** These bits are always read as 0 and cannot be modified.

**Bit 3—Frequency Multiplication Factor Switching Mode Select (STCS):** Selects the operation when the PLL circuit frequency multiplication factor is changed.

Bit 3	Description
0	Specified multiplication factor is valid after transition to software standby mode, watch mode*, or subactive mode* (Initial value)
1	Specified multiplication factor is valid immediately after STC bits are rewritten

Note: \* This function is not available in the H8S/2695.

**Bits 2 to 0—System Clock Select (SCK2 to SCK0):** These bits select the bus master clock in high-speed mode, medium-speed mode, and sub-active mode\*.

Set SCK2 to SCK0 all to 0 when shifting to operation in watch mode or sub-active mode\*.

Note: \* This function is not available in the H8S/2695.

Bit 2	Bit 1	Bit 0	Description
SCK2	SCK1	SCK0	
0	0	0	Bus master in high-speed mode (Initial value)
		1	Medium-speed clock is $\phi/2$
	1	0	Medium-speed clock is $\phi/4$
		1	Medium-speed clock is $\phi/8$
1	0	0	Medium-speed clock is $\phi/16$
		1	Medium-speed clock is $\phi/32$
	1	—	—

### 24.2.3 Low-Power Control Register (LPWRCCR)

#### H8S/2633 Series, H8S/2633R

Bit	:	7	6	5	4	3	2	1	0
		DTON	LSON	NESEL	SUBSTP	RFCUT	—	STC1	STC0
Initial value	:	0	0	0	0	0	0	0	0
R/W	:	R/W	R/W	R/W	R/W	R/W	R/W	R/W	R/W

#### H8S/2695

Bit	:	7	6	5	4	3	2	1	0
		—*	—*	—*	—*	—*	—	STC1	STC0
Initial value	:	0	0	0	0	0	0	0	0
R/W	:	R	R	R/W	R/W	R/W	R/W	R/W	R/W

Note: \* On the H8S/2695 only 0 should be written to these bits.

The LPWRCCR is an 8-bit read/write register that controls the low power dissipation modes.

The LPWRCCR is initialized to H'00 at a power-on reset and when in hardware standby mode. It is not initialized at a manual reset or when in software standby mode. The following describes bits 7 to 2. For details of other bits, see section 23A.2.2 and 23B.2.2, Low-Power Control Register (LPWRCCR).

**Bit 7—Direct Transition ON Flag (DTON):** When shifting to low power dissipation mode by executing the SLEEP instruction, this bit specifies whether or not to make a direct transition between high-speed mode or medium-speed mode and the sub-active modes\*. The selected operating mode after executing the SLEEP instruction is determined by the combination of other control bits.

Note: \* This function is not available in the H8S/2695.

**Bit 7**

DTON	Description
0	<ul style="list-style-type: none"> <li>• When the SLEEP instruction is executed in high-speed mode or medium-speed mode, operation shifts to sleep mode, software standby mode, or watch mode*<sup>1</sup> *<sup>2</sup>.</li> <li>• When the SLEEP instruction is executed in sub-active mode*<sup>2</sup>, operation shifts to sub-sleep mode*<sup>2</sup> or watch mode*<sup>2</sup>. (Initial value)</li> </ul>
1	<ul style="list-style-type: none"> <li>• When the SLEEP instruction is executed in high-speed mode or medium-speed mode, operation shifts directly*<sup>2</sup> to sub-active mode*<sup>1</sup> *<sup>2</sup>, or shifts to sleep mode or software standby mode.</li> <li>• When the SLEEP instruction is executed in sub-active mode, operation shifts directly to high-speed mode, or shifts to sub-sleep mode.</li> </ul>

Notes: \*1 Always set high-speed mode when shifting to watch mode or sub-active mode.

\*2 This function is not available in the H8S/2695.

**Bit 6—Low-Speed ON Flag (LSON):** When shifting to low power dissipation mode by executing the SLEEP instruction, this bit specifies the operating mode, in combination with other control bits. This bit also controls whether to shift to high-speed mode or sub-active mode\* when watch mode\* is cancelled.

Note: \* This function is not available in the H8S/2695.

**Bit 6**

LSON	Description
0	<ul style="list-style-type: none"> <li>When the SLEEP instruction is executed in high-speed mode or medium-speed mode, operation shifts to sleep mode, software standby mode, or watch mode*<sup>1</sup>*<sup>2</sup>.</li> <li>When the SLEEP instruction is executed in sub-active mode*<sup>2</sup>, operation shifts to watch mode*<sup>2</sup> or shifts directly*<sup>2</sup> to high-speed mode.</li> <li>Operation shifts to high-speed mode when watch mode is cancelled. (Initial value)</li> </ul>
1	<ul style="list-style-type: none"> <li>When the SLEEP instruction is executed in high-speed mode, operation shifts to watch mode*<sup>2</sup> or sub-active mode*<sup>2</sup>.</li> <li>When the SLEEP instruction is executed in sub-active mode*<sup>2</sup>, operation shifts to sub-sleep mode*<sup>2</sup> or watch mode*<sup>2</sup>.</li> <li>Operation shifts to sub-active*<sup>2</sup> mode when watch mode*<sup>2</sup> is cancelled.</li> </ul>

Notes: \*1 Always set high-speed mode when shifting to watch mode or sub-active mode.

\*2 This function is not available in the H8S/2695.

**Bit 5—Noise Elimination Sampling Frequency Select (NESEL):** This bit selects the sampling frequency of the subclock ( $\phi$ SUB) generated by the subclock oscillator is sampled by the clock ( $\phi$ ) generated by the system clock oscillator. Set this bit to 0 when  $\phi$ =5MHz or more.

**Bit 5**

NESEL	Description
0	Sampling using 1/32 $\times \phi$ (Initial value)
1	Sampling using 1/4 $\times \phi$

**Bit 4—Subclock enable (SUBSTP):** This bit enables/disables subclock generation.

**Bit 4**

SUBSTP	Description
0	Enables subclock generation (Initial value)
1	Disables subclock generation



**Bit 3—Oscillation Circuit Feedback Resistance Control Bit (RFCUT):** This bit turns the internal feedback resistance of the main clock oscillation circuit ON/OFF.

**Bit 3**

RFCUT	Description
0	When the main clock is oscillating, sets the feedback resistance ON. When the main clock is stopped, sets the feedback resistance OFF (Initial value)
1	Sets the feedback resistance OFF

**Bit 2—Reserved:** Should always be written with 0.

**24.2.4 Timer Control/Status Register (TCSR)**

WDT1 TCSR

Bit	:	7	6	5	4	3	2	1	0
		OVF	WT/IT	TME	PSS	RST/NMI	CKS2	CKS1	CKS0
Initial value	:	0	0	0	0	0	0	0	0
R/W	:	R/(W)*	R/W	R/W	R/W	R/W	R/W	R/W	R/W

Note: \* Only write 0 to clear the flag.

TCSR is an 8-bit read/write register that selects the clock input to WDT1 TCNT and the mode.

The following describes bit 4. For details of the other bits in this register, see section 15.2.2, Timer Control/Status Register (TCSR).

The TCSR is initialized to H'00 at a reset and when in hardware standby mode. It is not initialized in software standby mode.

**Bit 4—Prescaler select (PSS)\*1:** This bit selects the clock source input to WDT1 TCNT.

It also controls operation when shifting low power dissipation modes. The operating mode selected after the SLEEP instruction is executed is determined in combination with other control bits.

For details, see the description for clock selection in section 15.2.2, Timer Control/Status Register (TCSR), and this section.

**WDT1  
TCSR**

**Bit 4**

PSS* <sup>1</sup>	Description
0	<ul style="list-style-type: none"> <li>TCNT counts the divided clock from the <math>\emptyset</math>-based prescaler (PSM).</li> <li>When the SLEEP instruction is executed in high-speed mode or medium-speed mode, operation shifts to sleep mode or software standby mode. (Initial value)</li> </ul>
1	<ul style="list-style-type: none"> <li>TCNT counts the divided clock from the <math>\emptyset</math>subclock-based prescaler (PSS).</li> <li>When the SLEEP instruction is executed in high-speed mode or medium-speed mode, operation shifts to sleep mode, watch mode*<sup>2</sup>, or sub-active mode*<sup>2</sup>.</li> <li>When the SLEEP instruction is executed in sub-active mode, operation shifts to sub-sleep mode, watch mode, or high-speed mode.</li> </ul>

Notes: \*1 In the H8S/2695 only a 0 may be written to the PSS bit in the TCSR1 register.

\*2 Always set high-speed mode when shifting to watch mode or sub-active mode.

**24.2.5 Module Stop Control Register (MSTPCR)**

**MSTPCRA**

Bit	:	7	6	5	4	3	2	1	0
		MSTPA7	MSTPA6	MSTPA5	MSTPA4	MSTPA3	MSTPA2	MSTPA1	MSTPA0
Initial value :		0	0	1	1	1	1	1	1
R/W	:	R/W	R/W	R/W	R/W	R/W	R/W	R/W	R/W

**MSTPCRB**

Bit	:	7	6	5	4	3	2	1	0
		MSTPB7	MSTPB6	MSTPB5	MSTPB4	MSTPB3	MSTPB2	MSTPB1	MSTPB0
Initial value :		1	1	1	1	1	1	1	1
R/W	:	R/W	R/W	R/W	R/W	R/W	R/W	R/W	R/W

**MSTPCRC**

Bit	:	7	6	5	4	3	2	1	0
		MSTPC7	MSTPC6	MSTPC5	MSTPC4	MSTPC3	MSTPC2	MSTPC1	MSTPC0
Initial value :		1	1	1	1	1	1	1	1
R/W	:	R/W	R/W	R/W	R/W	R/W	R/W	R/W	R/W

MSTPCR, comprising three 8-bit readable/writable registers, performs module stop mode control.

MSTPCR is initialized to H'3FFFFFF by a reset and in hardware standby mode. It is not initialized in software standby mode.

**MSTPCRA/MSTPCRB/MSTPCRC Bits 7 to 0—Module Stop (MSTPA7 to MSTPA0, MSTPB7 to MSTPB0, MSTPC7 to MSTPC0):** These bits specify module stop mode. See table 24-4 for the method of selecting the on-chip peripheral functions.

**MSTPCRA/MSTPCRB/  
MSTPCRC Bits 7 to 0**

<b>MSTPA7 to MSTPA0, MSTPB7 to MSTPB0, MSTPC7 to MSTPC0</b>	<b>Description</b>
0	Module stop mode is cleared (initial value of MSTPA7 and MSTPA6)
1	Module stop mode is set (initial value of MSTPA5 to MSTPA0, MSTPB7 to MSTPB0, and MSTPC7 to MSTPC0)

### 24.3 Medium-Speed Mode

In high-speed mode, when the SCK2 to SCK0 bits in SCKCR are set to 1, the operating mode changes to medium-speed mode as soon as the current bus cycle ends. In medium-speed mode, the CPU operates on the operating clock ( $\phi/2$ ,  $\phi/4$ ,  $\phi/8$ ,  $\phi/16$ , or  $\phi/32$ ) specified by the SCK2 to SCK0 bits. The bus masters other than the CPU (the DMAC and DTC) also operate in medium-speed mode. On-chip supporting modules other than the bus masters always operate on the high-speed clock ( $\phi$ ).

In medium-speed mode, a bus access is executed in the specified number of states with respect to the bus master operating clock. For example, if  $\phi/4$  is selected as the operating clock, on-chip memory is accessed in 4 states, and internal I/O registers in 8 states.

Medium-speed mode is cleared by clearing all of bits SCK2 to SCK0 to 0. A transition is made to high-speed mode and medium-speed mode is cleared at the end of the current bus cycle.

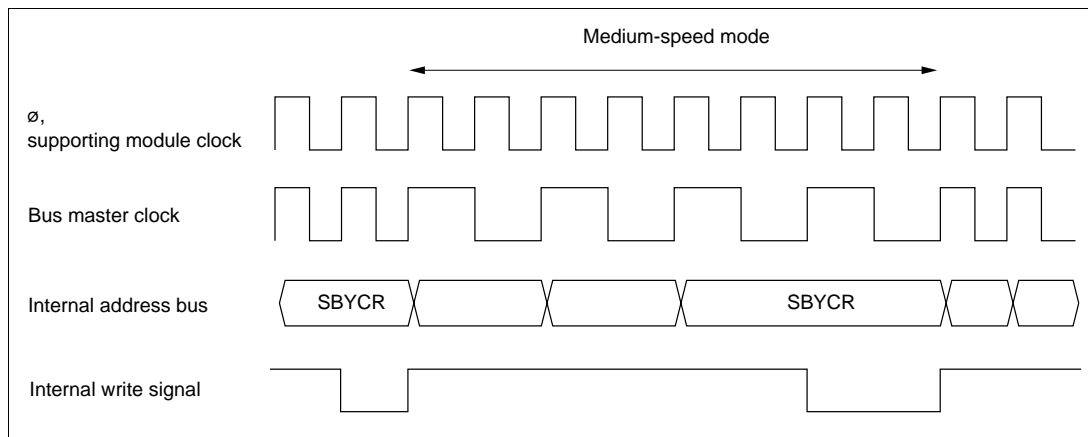
If a SLEEP instruction is executed when the SSBY bit in SBYCR is cleared to 0, and LSON bit in LPWRCR is cleared to 0, a transition is made to sleep mode. When sleep mode is cleared by an interrupt, medium-speed mode is restored.

When the SLEEP instruction is executed with the SSBY bit = 1, LPWRCR LSON bit = 0, and TCSR (WDT1) PSS bit = 0, operation shifts to the software standby mode. When software standby mode is cleared by an external interrupt, medium-speed mode is restored.

When the  $\overline{\text{RES}}$  and  $\overline{\text{MRES}}$  pins are set Low and medium-speed mode is cancelled, operation shifts to the reset state. The same applies in the case of a reset caused by overflow of the watchdog timer.

When the  $\overline{\text{STBY}}$  pin is driven low, a transition is made to hardware standby mode.

Figure 24-2 shows the timing for transition to and clearance of medium-speed mode.



**Figure 24-2 Medium-Speed Mode Transition and Clearance Timing**

## 24.4 Sleep Mode

### 24.4.1 Sleep Mode

When the SLEEP instruction is executed when the SBYCR SSBY bit = 0 and the LPWRCR LSON bit = 0, the CPU enters the sleep mode. In sleep mode, CPU operation stops but the contents of the CPU's internal registers are retained. Other supporting modules do not stop.

### 24.4.2 Exiting Sleep Mode

Sleep mode is exited by any interrupt, or signals at the  $\overline{\text{RES}}$ ,  $\overline{\text{MRES}}$ , or  $\overline{\text{STBY}}$  pins.

#### (1) Exiting Sleep Mode by Interrupts

When an interrupt occurs, sleep mode is exited and interrupt exception processing starts. Sleep mode is not exited if the interrupt is disabled, or interrupts other than NMI are masked by the CPU.

#### (2) Exiting Sleep Mode by $\overline{\text{RES}}$ or $\overline{\text{MRES}}$ Pins

Setting the  $\overline{\text{RES}}$  or  $\overline{\text{MRES}}$  pin level Low selects the reset state. After the stipulated reset input duration, driving the  $\overline{\text{RES}}$  and  $\overline{\text{MRES}}$  pins High starts the CPU performing reset exception processing.

#### (3) Exiting Sleep Mode by $\overline{\text{STBY}}$ Pin

When the  $\overline{\text{STBY}}$  pin level is driven low, a transition is made to hardware standby mode.

## 24.5 Module Stop Mode

### 24.5.1 Module Stop Mode

Module stop mode can be set for individual on-chip supporting modules.

When the corresponding MSTP bit in MSTPCR is set to 1, module operation stops at the end of the bus cycle and a transition is made to module stop mode. The CPU continues operating independently.

Table 24-4 shows MSTP bits and the corresponding on-chip supporting modules.

When the corresponding MSTP bit is cleared to 0, module stop mode is cleared and the module starts operating at the end of the bus cycle. In module stop mode, the internal states of modules other than the SCI, A/D converter and 14-bit PWM\* are retained.

After reset clearance, all modules other than DMAC\* and DTC\* are in module stop mode.

When an on-chip supporting module is in module stop mode, read/write access to its registers is disabled.

Note: \* This function is not available in the H8S/2695.

**Table 24-4 MSTP Bits and Corresponding On-Chip Supporting Modules**

Register	Bit	Module
MSTPCRA	MSTPA7	DMA controller (DMAC)* <sup>2</sup>
	MSTPA6	Data transfer controller (DTC)* <sup>2</sup>
	MSTPA5	16-bit timer pulse unit (TPU)
	MSTPA4	8-bit timer (TMR0, TMR1)* <sup>2</sup>
	MSTPA3	Programmable pulse generator (PPG)* <sup>2</sup>
	MSTPA2	D/A converter (channels 0, 1)* <sup>2</sup>
	MSTPA1	A/D converter
	MSTPA0	8-bit timer (TMR2, TMR3)* <sup>2</sup>
MSTPCRB	MSTPB7	Serial communication interface 0 (SCI0)
	MSTPB6	Serial communication interface 1 (SCI1)
	MSTPB5	Serial communication interface 2 (SCI2)
	MSTPB4	I <sup>2</sup> C bus interface 0 (IIC0)* <sup>2</sup>
	MSTPB3	I <sup>2</sup> C bus interface 1 (IIC1)* <sup>2</sup>
	MSTPB2	14-bit PWM timer (PWM0)* <sup>2</sup>
	MSTPB1	14-bit PWM timer (PWM1)* <sup>2</sup>
	MSTPB0* <sup>1</sup>	—
MSTPCRC	MSTPC7	Serial communication interface 3 (SCI3)
	MSTPC6	Serial communication interface 4 (SCI4)
	MSTPC5	D/A converter (channels 2, 3)* <sup>2</sup>
	MSTPC4	PC break controller (PBC)* <sup>2</sup>
	MSTPC3* <sup>1</sup>	—
	MSTPC2* <sup>1</sup>	—
	MSTPC1* <sup>1</sup>	—
	MSTPC0* <sup>1</sup>	—

Notes: \*1 Write 1 to bit MSTPB0 and bits MTSPC3 to MSTPC0.

\*2 This function is not available in the H8S/2695.

## 24.5.2 Usage Notes

**DMAC and DTC Module Stop (DMAC and DTC functions are not available in the H8S/2695):** Depending on the operating status of the DMAC and DTC, the MSTPA7 and MSTPA6 bits may not be set to 1. Setting of the DMAC or DTC module stop mode should be carried out only when the respective module is not activated.

For details, refer to section 8, DMA Controller (DMAC) and section 9, Data Transfer Controller (DTC).

**On-Chip Supporting Module Interrupt:** Relevant interrupt operations cannot be performed in module stop mode. Consequently, if module stop mode is entered when an interrupt has been requested, it will not be possible to clear the CPU interrupt source or the DMAC and DTC activation source. Interrupts should therefore be disabled before entering module stop mode.

**Writing to MSTPCR:** MSTPCR should only be written to by the CPU.

**Reading I/O Ports in Subactive Mode:** When operating in the subactive mode, reading the status of the I/O port pins, except for ports D and E, always returns a 1. Use of these pins as output ports is possible. The procedure for detecting the status of the I/O port pins in the subactive mode is as follows.

- (1) Use ports D and E as input ports.
- (2) Use external interrupt inputs (IRQ0 to IRQ7).

## 24.6 Software Standby Mode

### 24.6.1 Software Standby Mode

A transition is made to software standby mode when the SLEEP instruction is executed when the SBYCR SSBY bit = 1 and the LPWRCR LSON bit = 0, and the TCSR (WDT1) PSS bit = 0. In this mode, the CPU, on-chip supporting modules, and oscillator all stop. However, the contents of the CPU's internal registers, RAM data, and the states of on-chip supporting modules other than the SCI, A/D converter, and 14-bit PWM, and I/O ports, are retained. Whether the address bus and bus control signals are placed in the high-impedance state.

In this mode the oscillator stops, and therefore power dissipation is significantly reduced.

### 24.6.2 Exiting Software Standby Mode

Software standby mode is cleared by an external interrupt (NMI pin, or pins  $\overline{\text{IRQ0}}$  to  $\overline{\text{IRQ7}}$ ), or by means of the  $\overline{\text{RES}}$  pin,  $\overline{\text{MRES}}$  pin or  $\overline{\text{STBY}}$  pin.

### (1) Exiting Software Standby Mode with an Interrupt

When an NMI or IRQ0 to IRQ7 interrupt request signal is input, clock oscillation starts, and after the elapse of the time set in bits STS2 to STS0 in SBYCR, stable clocks are supplied to the entire chip, software standby mode is exited, and interrupt exception handling is started.

When exiting software standby mode with an IRQ0 to IRQ7 interrupt, set the corresponding enable bit to 1 and ensure that no interrupt with a higher priority than interrupts IRQ0 to IRQ7 is generated. Software standby mode cannot be exited if the interrupt has been masked on the CPU side or has been designated as a DTC activation source.

### (2) Exiting Software Standby Mode by $\overline{\text{RES}}$ or $\overline{\text{MRES}}$ Pins

When the  $\overline{\text{RES}}$  pin or  $\overline{\text{MRES}}$  pin is driven low, clock oscillation is started. At the same time as clock oscillation starts, clocks are supplied to the entire chip. Note that the  $\overline{\text{RES}}$  pin or  $\overline{\text{MRES}}$  pin must be held low until clock oscillation stabilizes. When the  $\overline{\text{RES}}$  pin or  $\overline{\text{MRES}}$  pin goes high, the CPU begins reset exception handling.

### (3) Exiting Software Standby Mode by $\overline{\text{STBY}}$ Pin

When the  $\overline{\text{STBY}}$  pin is driven low, a transition is made to hardware standby mode.

## 24.6.3 Setting Oscillation Stabilization Time after Clearing Software Standby Mode

Bits STS2 to STS0 in SBYCR should be set as described below.

**Using a Crystal Oscillator:** Set bits STS2 to STS0 so that the standby time is at least 8 ms (the oscillation stabilization time).

Table 24-5 shows the standby times for different operating frequencies and settings of bits STS2 to STS0.



**Table 24-5 Oscillation Stabilization Time Settings**

STS2	STS1	STS0	Standby Time	25 MHz	20 MHz	16 MHz	12 MHz	10 MHz	8 MHz	6 MHz	4 MHz	2 MHz	Unit
0	0	0	8192 states	0.32	0.41	0.51	0.65	0.8	1.0	1.3	2.0	4.1	ms
		1	16384 states	0.65	0.82	1.0	1.3	1.6	2.0	2.7	4.1	8.2	
	1	0	32768 states	1.3	1.6	2.0	2.7	3.3	4.1	5.5	8.2	16.4	
		1	65536 states	2.6	3.3	4.1	5.5	6.6	8.2	10.9	16.4	32.8	
1	0	0	131072 states	5.2	6.6	8.2	10.9	13.1	16.4	21.8	32.8	65.5	
		1	262144 states	10.4	13.1	16.4	21.8	26.2	32.8	43.6	65.6	131.2	
	1	0	Reserved	—	—	—	—	—	—	—	—	—	μs
		1	16 states (Setting prohibited)	0.6	0.8	1.0	1.3	1.6	2.0	1.7	4.0	8.0	

  : Recommended time setting

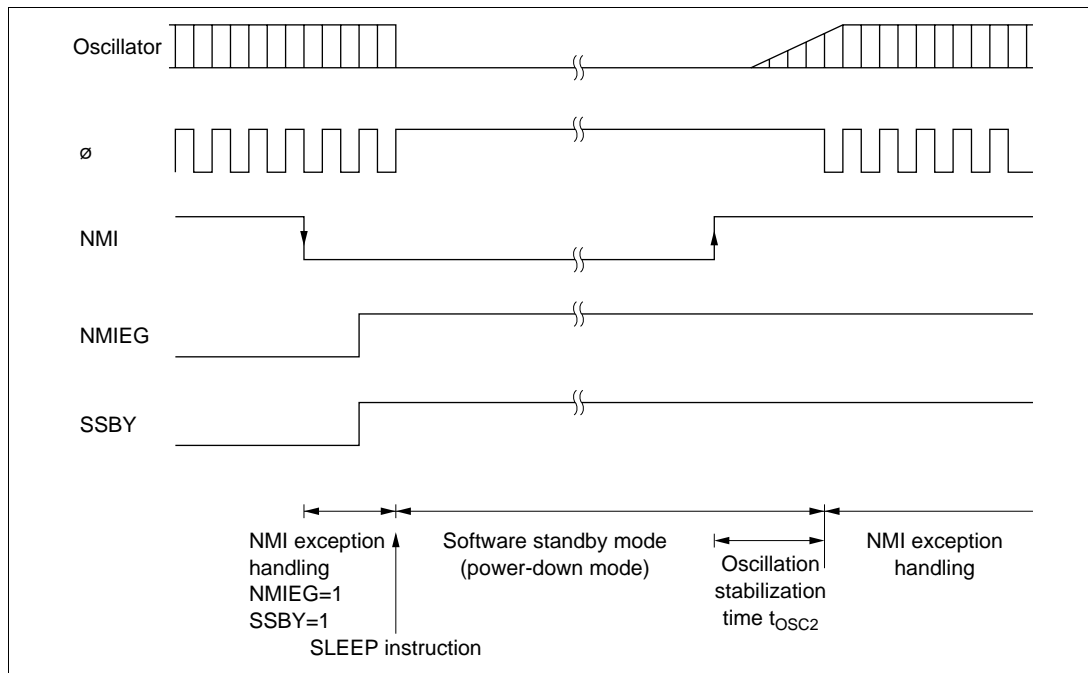
**Using an External Clock:** The PLL circuit requires a time for stabilization. Insert a wait of 2 ms min.

#### 24.6.4 Software Standby Mode Application Example

Figure 24-3 shows an example in which a transition is made to software standby mode at the falling edge on the NMI pin, and software standby mode is cleared at the rising edge on the NMI pin.

In this example, an NMI interrupt is accepted with the NMIEG bit in SYSCR cleared to 0 (falling edge specification), then the NMIEG bit is set to 1 (rising edge specification), the SSBY bit is set to 1, and a SLEEP instruction is executed, causing a transition to software standby mode.

Software standby mode is then cleared at the rising edge on the NMI pin.



**Figure 24-3 Software Standby Mode Application Example**

#### 24.6.5 Usage Notes

**I/O Port Status:** In software standby mode, I/O port states are retained. If the OPE bit is set to 1, the address bus and bus control signal output is also retained. Therefore, there is no reduction in current dissipation for the output current when a high-level signal is output.

**Current Dissipation during Oscillation Stabilization Wait Period:** Current dissipation increases during the oscillation stabilization wait period.

**Write Data Buffer Function:** The write data buffer function and software standby mode cannot be used at the same time. When the write data buffer function is used, the WDBE bit in BCRL should be cleared to 0 to cancel the write data buffer function before entering software standby mode. Also check that external writes have finished, by reading external addresses, etc., before executing a SLEEP instruction to enter software standby mode. See section 7.9, Write Data Buffer Function, for details of the write data buffer function.

## 24.7 Hardware Standby Mode

### 24.7.1 Hardware Standby Mode

When the  $\overline{\text{STBY}}$  pin is driven low, a transition is made to hardware standby mode from any mode.

In hardware standby mode, all functions enter the reset state and stop operation, resulting in a significant reduction in power dissipation. As long as the prescribed voltage is supplied, on-chip RAM data is retained. I/O ports are set to the high-impedance state.

In order to retain on-chip RAM data, the RAME bit in SYSCR should be cleared to 0 before driving the  $\overline{\text{STBY}}$  pin low.

Do not change the state of the mode pins (MD2 to MD0) while the H8S/2633 Series is in hardware standby mode.

Hardware standby mode is cleared by means of the  $\overline{\text{STBY}}$  pin and the  $\overline{\text{RES}}$  pin. When the  $\overline{\text{STBY}}$  pin is driven high while the  $\overline{\text{RES}}$  pin is low, the reset state is set and clock oscillation is started. Ensure that the RES pin is held low until the clock oscillator stabilizes (at least 8 ms—the oscillation stabilization time—when using a crystal oscillator). When the  $\overline{\text{RES}}$  pin is subsequently driven high, a transition is made to the program execution state via the reset exception handling state.

### 24.7.2 Hardware Standby Mode Timing

Figure 24-4 shows an example of hardware standby mode timing.

When the  $\overline{\text{STBY}}$  pin is driven low after the  $\overline{\text{RES}}$  pin has been driven low, a transition is made to hardware standby mode. Hardware standby mode is cleared by driving the  $\overline{\text{STBY}}$  pin high, waiting for the oscillation stabilization time, then changing the  $\overline{\text{RES}}$  pin from low to high.

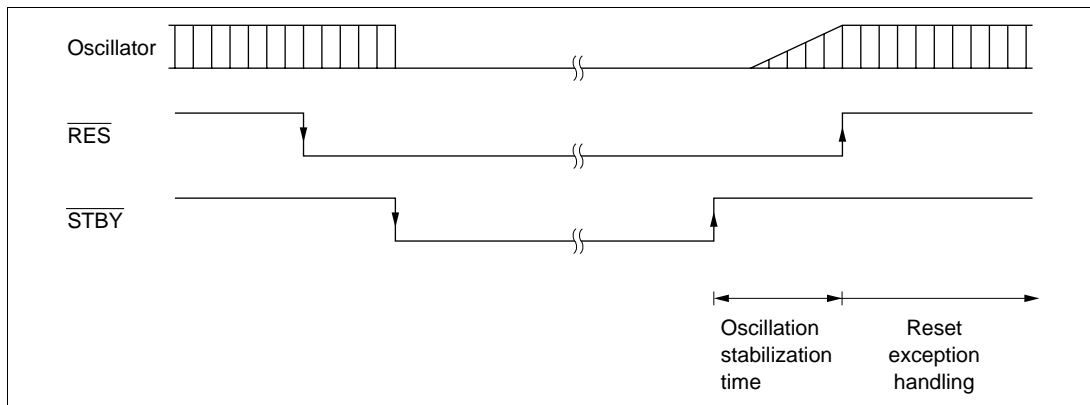


Figure 24-4 Hardware Standby Mode Timing

## 24.8 Watch Mode (This function is not available in the H8S/2695)

### 24.8.1 Watch Mode

CPU operation makes a transition to watch mode when the SLEEP instruction is executed in high-speed mode or sub-active mode with SBYCR SSBY=1, LPWRCR DTON = 0, and TCSR (WDT1) PSS = 1.

In watch mode, the CPU is stopped and supporting modules other than WDT1 are also stopped. The contents of the CPU's internal registers, the data in internal RAM, and the statuses of the internal supporting modules (excluding the SCI, ADC, and 14-bit PWM) and I/O ports are retained.

### 24.8.2 Exiting Watch Mode

Watch mode is exited by any interrupt (WOVI1 interrupt, NMI pin, or  $\overline{\text{IRQ0}}$  to  $\overline{\text{IRQ7}}$ ), or signals at the  $\overline{\text{RES}}$ ,  $\overline{\text{MRES}}$ , or  $\overline{\text{STBY}}$  pins.

#### (1) Exiting Watch Mode by Interrupts

When an interrupt occurs, watch mode is exited and a transition is made to high-speed mode or medium-speed mode when the LPWRCR LSON bit = 0 or to sub-active mode when the LSON bit = 1. When a transition is made to high-speed mode, a stable clock is supplied to all LSI circuits and interrupt exception processing starts after the time set in SBYCR STS2 to STS0 has elapsed. In the case of IRQ0 to IRQ7 interrupts, no transition is made from watch mode if the corresponding enable bit has been cleared to 0, and, in the case of interrupts from the internal supporting modules, the interrupt enable register has been set to disable the reception of that interrupt, or is masked by the CPU.

See section 24.6.3, Setting Oscillation Stabilization Time after Clearing Software Standby Mode for how to set the oscillation stabilization time when making a transition from watch mode to high-speed mode.

#### (2) Exiting Watch Mode by $\overline{\text{RES}}$ or $\overline{\text{MRES}}$ Pins

For exiting watch mode by the  $\overline{\text{RES}}$  or  $\overline{\text{MRES}}$  pins, see (2), Exiting Software Standby Mode by  $\overline{\text{RES}}$  or  $\overline{\text{MRES}}$  pins in section 24.6.2, Exiting Software Standby Mode.

#### (3) Exiting Watch Mode by $\overline{\text{STBY}}$ Pin

When the  $\overline{\text{STBY}}$  pin level is driven low, a transition is made to hardware standby mode.

### 24.8.3 Notes

#### (1) I/O Port Status

The status of the I/O ports is retained in watch mode. Also, when the OPE bit is set to 1, the address bus and bus control signals continue to be output. Therefore, when a High level is output, the current consumption is not diminished by the amount of current to support the High level output.

#### (2) Current Consumption when Waiting for Oscillation Stabilization

The current consumption increases during stabilization of oscillation.

#### (3) DMAC/DTC activation and sub-active mode/watch mode transition

When a transition is made to sub-active mode or watch mode, make a module stop setting for the DMAC/DTC (write 1 to the corresponding bit in MSTPCR), then read 1 from that bit for confirmation, before making the mode transition.

When exiting the module stop state (by writing 0 to the corresponding bit in MSTPCR), first make a transition from sub-active mode to active mode.

If a DMAC/DTC activation source occurs in sub-active mode, the DMAC/DTC is activated when the module stop state is exited after a transition is made to active mode.

#### (4) Interrupt sources and sub-active mode/watch mode transition

For on-chip peripheral modules that stop operating in sub-active mode (DMAC, DTC, TPU, FRT, TMRX, TMRY, timer connection, I<sup>2</sup>C), a corresponding interrupt cannot be cleared in sub-active mode. Therefore, CPU interrupt source clearance cannot be effected if a transition is made to sub-active mode when an interrupt has been requested.

Interrupts for these modules should be disabled before executing a SLEEP instruction and making a transition to sub-active mode or watch mode.

## 24.9 Sub-Sleep Mode (This function is not available in the H8S/2695)

### 24.9.1 Sub-Sleep Mode

When the SLEEP instruction is executed with the SBYCR SSBY bit = 0, LPWRCR LSON bit = 1, and TCSR (WDT1) PSS bit = 1, CPU operation shifts to sub-sleep mode.

In sub-sleep mode, the CPU is stopped. Supporting modules other than TMR0 to TMR3, WDT0, and WDT1 are also stopped. The contents of the CPU's internal registers, the data in internal RAM, and the statuses of the internal supporting modules (excluding the SCI, ADC, and 14-bit PWM) and I/O ports are retained.

## 24.9.2 Exiting Sub-Sleep Mode

Sub-sleep mode is exited by an interrupt (interrupts from internal supporting modules, NMI pin, or  $\overline{\text{IRQ0}}$  to  $\overline{\text{IRQ7}}$ ), or signals at the  $\overline{\text{RES}}$ ,  $\overline{\text{MRES}}$ , or  $\overline{\text{STBY}}$  pins.

### (1) Exiting Sub-Sleep Mode by Interrupts

When an interrupt occurs, sub-sleep mode is exited and interrupt exception processing starts.

In the case of  $\overline{\text{IRQ0}}$  to  $\overline{\text{IRQ7}}$  interrupts, sub-sleep mode is not cancelled if the corresponding enable bit has been cleared to 0, and, in the case of interrupts from the internal supporting modules, the interrupt enable register has been set to disable the reception of that interrupt, or is masked by the CPU.

### (2) Exiting Sub-Sleep Mode by $\overline{\text{RES}}$ or $\overline{\text{MRES}}$ Pins

For exiting sub-sleep mode by the  $\overline{\text{RES}}$  or  $\overline{\text{MRES}}$  pins, see (2), Exiting Software Standby Mode by  $\overline{\text{RES}}$  or  $\overline{\text{MRES}}$  pins in section 24.6.2, Exiting Software Standby Mode.

### (3) Exiting Sub-Sleep Mode by $\overline{\text{STBY}}$ Pin

When the  $\overline{\text{STBY}}$  pin level is driven low, a transition is made to hardware standby mode.

## 24.10 Sub-Active Mode (This function is not available in the H8S/2695)

### 24.10.1 Sub-Active Mode

When the SLEEP instruction is executed in high-speed mode with the SBYCR SSBY bit = 1, LPWRCCR DTON bit = 1, LSON bit = 1, and TCSR (WDT1) PSS bit = 1, CPU operation shifts to sub-active mode. When an interrupt occurs in watch mode, and if the LSON bit of LPWRCCR is 1, a transition is made to sub-active mode. And if an interrupt occurs in sub-sleep mode, a transition is made to sub-active mode.

In sub-active mode, the CPU operates at low speed on the subclock, and the program is executed step by step. Supporting modules other than TMR0 to TMR3, WDT0, and WDT1 are also stopped.

When operating the CPU in sub-active mode, the SCKCR SCK2 to SCK0 bits must be set to 0.

### 24.10.2 Exiting Sub-Active Mode

Sub-active mode is exited by the SLEEP instruction or the  $\overline{\text{RES}}$ ,  $\overline{\text{MRES}}$ , or  $\overline{\text{STBY}}$  pins.

### **(1) Exiting Sub-Active Mode by SLEEP Instruction**

When the SLEEP instruction is executed with the SBYCR SSBY bit = 1, LPWRCR DTON bit = 0, and TCSR (WDT1) PSS bit = 1, the CPU exits sub-active mode and a transition is made to watch mode. When the SLEEP instruction is executed with the SBYCR SSBY bit = 0, LPWRCR LSON bit = 1, and TCSR (WDT1) PSS bit = 1, a transition is made to sub-sleep mode. Finally, when the SLEEP instruction is executed with the SBYCR SSBY bit = 1, LPWRCR DTON bit = 1, LSON bit = 0, and TCSR (WDT1) PSS bit = 1, a direct transition is made to high-speed mode (SCK0 to SCK2 all 0).

See section 24.11, Direct Transitions for details of direct transitions.

### **(2) Exiting Sub-Active Mode by $\overline{\text{RES}}$ or $\overline{\text{MRES}}$ Pins**

For exiting sub-active mode by the  $\overline{\text{RES}}$  or  $\overline{\text{MRES}}$  pins, see (2), Exiting Software Standby Mode by  $\overline{\text{RES}}$  or  $\overline{\text{MRES}}$  pins in section 24.6.2, Exiting Software Standby Mode.

### **(3) Exiting Sub-Active Mode by $\overline{\text{STBY}}$ Pin**

When the  $\overline{\text{STBY}}$  pin level is driven Low, a transition is made to hardware standby mode.

## **24.10.3 Usage Notes**

### **(1) DMAC/DTC activation and sub-active mode/watch mode transition**

When a transition is made to sub-active mode or watch mode, make a module stop setting for the DMAC/DTC (write 1 to the corresponding bit in MSTPCR), then read 1 from that bit for confirmation, before making the mode transition.

When exiting the module stop state (by writing 0 to the corresponding bit in MSTPCR), first make a transition from sub-active mode to active mode.

If a DMAC/DTC activation source occurs in sub-active mode, the DMAC/DTC is activated when the module stop state is exited after a transition is made to active mode.

### **(2) Interrupt sources and sub-active mode/watch mode transition**

For on-chip peripheral modules that stop operating in sub-active mode (DMAC, DTC, TPU, FRT, TMRX, TMRY, timer connection, IIC), a corresponding interrupt cannot be cleared in sub-active mode. Therefore, CPU interrupt source clearance cannot be effected if a transition is made to sub-active mode when an interrupt has been requested.

Interrupts for these modules should be disabled before executing a SLEEP instruction and making a transition to sub-active mode or watch mode.

## 24.11 Direct Transitions (This function is not available in the H8S/2695)

### 24.11.1 Overview of Direct Transitions

There are three modes, high-speed, medium-speed, and sub-active, in which the CPU executes programs. When a direct transition is made, there is no interruption of program execution when shifting between high-speed and sub-active modes. Direct transitions are enabled by setting the LPWRCCR DTON bit to 1, then executing the SLEEP instruction. After a transition, direct transition interrupt exception processing starts.

#### (1) Direct Transitions from High-Speed Mode to Sub-Active Mode

Execute the SLEEP instruction in high-speed mode when the SBYCR SSBY bit = 1, LPWRCCR LSON bit = 1, and DTON bit = 1, and TSCR (WDT1) PSS bit = 1 to make a transition to sub-active mode.

#### (2) Direct Transitions from Sub-Active Mode to High-Speed Mode

Execute the SLEEP instruction in sub-active mode when the SBYCR SSBY bit = 1, LPWRCCR LSON bit = 0, and DTON bit = 1, and TSCR (WDT1) PSS bit = 1 to make a direct transition to high-speed mode after the time set in SBYCR STS2 to STS0 has elapsed.

## 24.12 $\phi$ Clock Output Disabling Function

Output of the  $\phi$  clock can be controlled by means of the PSTOP bit in SCKCR, and DDR for the corresponding port. When the PSTOP bit is set to 1, the  $\phi$  clock stops at the end of the bus cycle, and  $\phi$  output goes high.  $\phi$  clock output is enabled when the PSTOP bit is cleared to 0. When DDR for the corresponding port is cleared to 0,  $\phi$  clock output is disabled and input port mode is set. Table 24-6 shows the state of the  $\phi$  pin in each processing state.

**Table 24-6  $\phi$  Pin State in Each Processing State**

DDR	0	1	1
PSTOP	—	0	1
Hardware standby mode	High impedance	High impedance	High impedance
Software standby mode, watch mode*, and direct transition*	High impedance	Fixed high	Fixed high
Sleep mode and subsleep mode*	High impedance	$\phi$ output	Fixed high
High-speed mode, medium-speed mode, and subactive mode*	High impedance	$\phi$ output	Fixed high

Note: \* This function is not available in the H8S/2695.



## Section 25 Electrical Characteristics (H8S/2633, H8S/2632, H8S/2631, H8S/2633F)

### 25.1 Absolute Maximum Ratings

Table 25-1 lists the absolute maximum ratings. Unless specified otherwise,  $PV_{CC}$  refers to both  $PV_{CC1}$  and  $PV_{CC2}$ .

**Table 25-1 Absolute Maximum Ratings**

Item	Symbol	Value	Unit
Power supply voltage	$V_{CC}$	-0.3 to +4.3	V
	$PLL V_{CC}$		
	$PV_{CC1,2}$	-0.3 to +7.0	V
Input voltage (XTAL, EXTAL, OSC1, OSC2)	$V_{in}$	-0.3 to $V_{CC} + 0.3$	V
Input voltage (ports 4 and 9)	$V_{in}$	-0.3 to $AV_{CC} + 0.3$	V
Input voltage (except XTAL, EXTAL, OSC1, OSC2, ports 4 and 9)	$V_{in}$	-0.3 to $PV_{CC} + 0.3$	V
Reference voltage	$V_{ref}$	-0.3 to $AV_{CC} + 0.3$	V
Analog power supply voltage	$AV_{CC}$	-0.3 to +7.0	V
Analog input voltage	$V_{AN}$	-0.3 to $AV_{CC} + 0.3$	V
Operating temperature	$T_{opr}$	Regular specifications: -20 to +75	°C
		Wide-range specifications: -40 to +85	°C
Storage temperature	$T_{stg}$	-55 to +125	°C

Caution: Permanent damage to the chip may result if absolute maximum rating are exceeded.

## 25.2 DC Characteristics

Table 25-2 lists the DC characteristics. Table 25-3 lists the permissible output currents.

**Table 25-2 DC Characteristics (1)**

Conditions:  $V_{CC} = PLLV_{CC} = 3.0\text{ V to }3.6\text{ V}$ ,  $PV_{CC} = 4.5\text{ V to }5.5\text{ V}$ ,  $AV_{CC} = 4.5\text{ V to }5.5\text{ V}$ ,  
 $V_{ref} = 4.5\text{ V to }AV_{CC}$ ,  $V_{SS} = AV_{SS} = PLLV_{SS} = 0\text{ V}$ ,  $T_a = -20^\circ\text{C to }+75^\circ\text{C}$  (regular specifications),  $T_a = -40^\circ\text{C to }+85^\circ\text{C}$  (wide-range specifications)\*<sup>1</sup>

Item	Symbol	Min	Typ	Max	Unit	Test Conditions
Schmitt trigger input voltage	$\overline{IRQ7}$ to $\overline{IRQ0}$	$V_T^-$	1.0	—	—	V
		$V_T^+$	—	—	$PV_{CC} \times 0.7$	V
		$V_T^+ - V_T^-$	0.4	—	—	V
Input high voltage	$\overline{RES}$ , $\overline{STBY}$ , NMI, $FWE^{*5}$ , MD2 to MD0	$V_{IH}$	$PV_{CC} - 0.7$	—	$PV_{CC} + 0.3$	V
	EXTAL, OSC1		$V_{CC} \times 0.8$	—	$V_{CC} + 0.3$	V
	Ports 1, 3, 7, A to G		2.2	—	$PV_{CC} + 0.3$	V
	Ports 4 and 9		$AV_{CC} \times 0.7$	—	$AV_{CC} + 0.3$	V
Input low voltage	$\overline{RES}$ , $\overline{STBY}$ , NMI, $FWE^{*5}$ , MD2 to MD0	$V_{IL}$	-0.3	—	0.5	V
	EXTAL, OSC1		-0.3	—	$V_{CC} \times 0.2$	V
	Ports 1, 3, 4, 7, 9, A to G		-0.3	—	0.8	V
Output high voltage	All output pins except P34 and P35	$V_{OH}$	$PV_{CC} - 0.5$	—	—	V $I_{OH} = -200\ \mu\text{A}$
	P34, P35		$PV_{CC} - 2.5$	—	—	V $I_{OH} = -100\ \mu\text{A}$
	All output pins except P34 and P35		3.5	—	—	V $I_{OH} = -1\ \text{mA}$
Output low voltage	All output pins	$V_{OL}$	—	—	0.4	V $I_{OL} = 1.6\ \text{mA}$
Input leakage current	$\overline{RES}$ , $FWE^{*5}$	$ I_{in} $	—	—	1.0	$\mu\text{A}$ $V_{in} = 0.5\text{ V to }PV_{CC} - 0.5\text{ V}$
	$\overline{STBY}$ , NMI, MD2 to MD0		—	—	1.0	$\mu\text{A}$
	Ports 4, 9		—	—	1.0	$\mu\text{A}$ $V_{in} = 0.5\text{ V to }AV_{CC} - 0.5\text{ V}$

Item		Symbol	Min	Typ	Max	Unit	Test Conditions
Three-state leakage current (off state)	Ports 1, 3, 7, A to G	$ I_{TSL} $	—	—	1.0	$\mu\text{A}$	$V_{in} = 0.5 \text{ V}$ to $PV_{CC} - 0.5 \text{ V}$
MOS input pull-up current	Ports A to E	$-I_P$	50	—	300	$\mu\text{A}$	$V_{in} = 0 \text{ V}$
Input capacitance	$\overline{\text{RES}}$	$C_{in}$	—	—	30	pF	$V_{in} = 0 \text{ V}$
	NMI		—	—	30	pF	$f = 1 \text{ MHz}$
	All input pins except $\overline{\text{RES}}$ and NMI		—	—	15	pF	$T_a = 25^\circ\text{C}$
Current dissipation* <sup>2</sup>	Normal operation	$I_{CC}^{*4}$	—	72	85	mA	$f = 25 \text{ MHz}$
				$V_{CC} = 3.3 \text{ V}$	$V_{CC} = 3.6 \text{ V}$		
	Sleep mode		—	58	75	mA	$f = 25 \text{ MHz}$
				$V_{CC} = 3.3 \text{ V}$	$V_{CC} = 3.6 \text{ V}$		
	All modules stopped		—	50	—	mA	$f = 25 \text{ MHz}$ , $V_{CC} = 3.3 \text{ V}$ (reference values)
	Medium-speed mode ( $\phi/32$ )		—	40	—		
	Subactive mode		—	120	200	$\mu\text{A}$	Using 32.768 kHz crystal resonator
				$V_{CC} = 3.0 \text{ V}$	$T_a = 25^\circ\text{C}$		
Subsleep mode	—	70	150	$\mu\text{A}$	Using 32.768 kHz crystal resonator		
		$V_{CC} = 3.0 \text{ V}$	$T_a = 25^\circ\text{C}$				
Watch mode	—	20	50	$\mu\text{A}$	Using 32.768 kHz crystal resonator		
		$V_{CC} = 3.0 \text{ V}$	$T_a = 25^\circ\text{C}$				
Standby mode		—	1.0	5.0	$\mu\text{A}$	$T_a \leq 50^\circ\text{C}$	
		—	—	20		$50^\circ\text{C} < T_a$	

Item		Symbol	Min	Typ	Max	Unit	Test Conditions
Port power supply current* <sup>2</sup>	Operating	$I_{CC}$	—	17 $PV_{CC} = 5.0\text{ V}$	25	mA	
	Subclock operation		—	—	50	$\mu\text{A}$	
	Standby Watch mode		—	0.01	5.0		$T_a \leq 50\text{ }^\circ\text{C}$
Analog power supply current	During A/D and D/A conversion	$I_{CC}$	—	0.6	2.0	mA	$AV_{CC} = 5.0\text{ V}$
	Idle		—	0.01 $T_a = 25\text{ }^\circ\text{C}$	5.0	$\mu\text{A}$	
Reference power supply current	During A/D and D/A conversion	$I_{CC}$	—	4.0	5.0	mA	$V_{ref} = 5.0\text{ V}$
	Idle		—	0.01 $T_a = 25\text{ }^\circ\text{C}$	5.0	$\mu\text{A}$	
RAM standby voltage* <sup>3</sup>		$V_{RAM}$	2.0	—	—	V	

Notes: \*1 If the A/D and D/A converters are not used, do not leave the  $AV_{CC}$ ,  $V_{ref}$ , and  $AV_{SS}$  pins open. Apply a voltage between 3.3 V and 5.5 V to the  $AV_{CC}$  and  $V_{ref}$  pins by connecting them to  $PV_{CC}$ , for instance. Set  $V_{ref} \leq AV_{CC}$ .

\*2 Current dissipation values are for  $V_{IH} = V_{CC}$  (EXTAL, OSC1),  $AV_{CC}$  (ports 4 and 9), or  $PV_{CC}$  (other), and  $V_{IL} = 0\text{ V}$ , with all output pins unloaded and the on-chip MOS pull-up transistors in the off state.

\*3 The values are for  $V_{RAM} \leq V_{CC} < 3.0\text{ V}$ ,  $V_{IH\ min} = V_{CC} - 0.1\text{ V}$ , and  $V_{IL\ max} = 0.1\text{ V}$ .

\*4  $I_{CC}$  depends on  $V_{CC}$  and  $f$  as follows:

$$I_{CC\ max} = 1.0\text{ (mA)} + 0.93\text{ (mA/(MHz} \times \text{V))} \times V_{CC} \times f\text{ (normal operation)}$$

$$I_{CC\ max} = 1.0\text{ (mA)} + 0.77\text{ (mA/(MHz} \times \text{V))} \times V_{CC} \times f\text{ (sleep mode)}$$

\*5 The FWE pin is used only in the flash memory version.

**Table 25-2 DC Characteristics (2)**

Conditions:  $V_{CC} = PLLV_{CC} = 3.0\text{ V to }3.6\text{ V}$ ,  $PV_{CC} = 3.0\text{ V to }5.5\text{ V}$ ,  $AV_{CC} = 3.6\text{ V to }5.5\text{ V}^{*7}$ ,  
 $V_{ref} = 3.6\text{ V to }AV_{CC}^{*8}$ ,  $V_{SS} = AV_{SS} = PLLV_{SS} = 0\text{ V}$ ,  $T_a = -20^\circ\text{C to }+75^\circ\text{C}$  (regular specifications),  $T_a = -40^\circ\text{C to }+85^\circ\text{C}$  (wide-range specifications)\*<sup>1</sup>

Item	Symbol	Min	Typ	Max	Unit	Test Conditions
Schmitt trigger input voltage	$\overline{IRQ7}$ to $\overline{IRQ0}$	$V_T^-$	$PV_{CC} \times 0.2$	—	—	V
		$V_T^+$	—	—	$PV_{CC} \times 0.7$	V
		$V_T^+ - V_T^-$	$PV_{CC} \times 0.05$	—	—	V
Input high voltage	$\overline{RES}$ , $\overline{STBY}$ , $\overline{FWE}^{*6}$ , $\overline{NMI}$ , MD2 to MD0	$V_{IH}$	$PV_{CC} \times 0.9$	—	$PV_{CC} + 0.3$	V
	EXTAL, OSC1		$V_{CC} \times 0.8$	—	$V_{CC} + 0.3$	V
	Ports 1, 3, 7, A to G		$PV_{CC} \times 0.8$	—	$PV_{CC} + 0.3$	V
	Ports 4 and 9		$AV_{CC} \times 0.8$	—	$AV_{CC} + 0.3$	V
Input low voltage	$\overline{RES}$ , $\overline{STBY}$ , $\overline{NMI}$ , $\overline{FWE}^{*6}$ , MD2 to MD0	$V_{IL}$	-0.3	—	$PV_{CC} \times 0.1$	V
	EXTAL, OSC1		-0.3	—	$V_{CC} \times 0.2$	V
	Ports 1, 3, 7, A to G		-0.3	—	$PV_{CC} \times 0.2$	V
	Ports 4 and 9		-0.3	—	$AV_{CC} \times 0.2$	V
Output high voltage	All output pins except P34 and P35	$V_{OH}$	$PV_{CC} - 0.5$	—	—	V $I_{OH} = -200\ \mu\text{A}$
	P34, P35		$PV_{CC} - 2.5$	—	—	$I_{OH} = -100\ \mu\text{A}^{*2}$
	All output pins except P34 and P35		$PV_{CC} - 1.0$	—	—	$I_{OH} = -1\text{mA}$
Output low voltage	All output pins	$V_{OL}$	—	—	0.4	V $I_{OL} = 1.6\ \text{mA}$
Input leakage current	$\overline{RES}$ , $\overline{FWE}^{*6}$	$ I_{in} $	—	—	1.0	$\mu\text{A}$ $V_{in} = 0.5\ \text{V to }PV_{CC} - 0.5\ \text{V}$
	$\overline{STBY}$ , $\overline{NMI}$ , MD2 to MD0		—	—	1.0	$\mu\text{A}$
	Ports 4, 9		—	—	1.0	$\mu\text{A}$ $V_{in} = 0.5\ \text{V to }AV_{CC} - 0.5\ \text{V}$

Item	Symbol	Min	Typ	Max	Unit	Test Conditions	
Three-state leakage current (off state)	Ports 1, 3, 7, A to G $ I_{TSI} $	—	—	1.0	$\mu\text{A}$	$V_{in} = 0.5 \text{ V}$ to $V_{CC} - 0.5 \text{ V}$	
MOS input pull-up current	Ports A to E $-I_p$	25	—	300	$\mu\text{A}$	$V_{in} = 0 \text{ V}$	
Input capacitance	$\overline{\text{RES}}$	$C_{in}$	—	—	30	$\text{pF}$	$V_{in} = 0 \text{ V}$
	NMI		—	—	30	$\text{pF}$	$f = 1 \text{ MHz}$
	All input pins except $\overline{\text{RES}}$ and NMI		—	—	15	$\text{pF}$	$T_a = 25^\circ\text{C}$
Current dissipation* <sup>3</sup>	Normal operation	$I_{CC}^{*5}$	—	40	60	$\text{mA}$	$f = 16 \text{ MHz}$
				$V_{CC} = 3.3 \text{ V}$	$V_{CC} = 3.6 \text{ V}$		
	Sleep mode		—	35	45	$\text{mA}$	$f = 16 \text{ MHz}$
				$V_{CC} = 3.3 \text{ V}$	$V_{CC} = 3.6 \text{ V}$		
	All modules stopped		—	30	—	$\text{mA}$	$f = 16 \text{ MHz}$ , $V_{CC} = 3.3 \text{ V}$ (reference values)
	Medium-speed mode ( $\emptyset/32$ )		—	25	—	$\text{mA}$	$f = 16 \text{ MHz}$ , $V_{CC} = 3.3 \text{ V}$ (reference values)
	Subactive mode		—	120	200	$\mu\text{A}$	Using 32.768 kHz crystal resonator
				$V_{CC} = 3.0 \text{ V}$ $T_a = 25^\circ\text{C}$			
Subsleep mode	—	70	150	$\mu\text{A}$	Using 32.768 kHz crystal resonator		
		$V_{CC} = 3.0 \text{ V}$ $T_a = 25^\circ\text{C}$					
Watch mode	—	20	50	$\mu\text{A}$	Using 32.768 kHz crystal resonator		
		$V_{CC} = 3.0 \text{ V}$ $T_a = 25^\circ\text{C}$					
Standby mode	—	—	0.01	5.0	$\mu\text{A}$	$T_a \leq 50^\circ\text{C}$	
	—	—	—	20		$50^\circ\text{C} < T_a$	

Item		Symbol	Min	Typ	Max	Unit	Test Conditions
Port power supply current* <sup>3</sup>	Operating	$PI_{CC}$	—	10 $PV_{CC} = 5.0\text{ V}$	16	mA	
	Subclock operation		—	—	50	$\mu\text{A}$	
	Standby Watch mode		—	0.01	5.0		$T_a \leq 50^\circ\text{C}$
			—	—	20		$50^\circ\text{C} < T_a$
Analog power supply current	During A/D and D/A conversions	$AI_{CC}$	—	0.6	2.0	mA	$V_{CC} = 5.0\text{ V}$
	Idle		—	0.01 $T_a = 25^\circ\text{C}$	5.0	$\mu\text{A}$	
Reference current	During A/D and D/A conversions	$AI_{CC}$	—	4.0	5.0	mA	$AV_{ref} = 5.0\text{ V}$
	Idle		—	0.01 $T_a = 25^\circ\text{C}$	5.0	$\mu\text{A}$	
RAM standby voltage* <sup>4</sup>		$V_{RAM}$	2.0	—	—	V	

Notes: \*1 If the A/D and D/A converters are not used, do not leave the  $AV_{CC}$ ,  $V_{ref}$ , and  $AV_{SS}$  pins open. Apply a voltage between 3.3 V to 5.5 V to the  $AV_{CC}$  and  $V_{ref}$  pins by connecting them to  $PV_{CC}$ , for instance. Set  $V_{ref} \leq AV_{CC}$ .

\*2 When using P34 and P35 as output pins, set  $PV_{CC} = 3.3\text{ V}$  to 5.5 V.

\*3 Current dissipation values are for  $V_{IH} = V_{CC}$  (EXTAL, OSC1),  $AV_{CC}$  (ports 4 and 9), or  $PV_{CC}$  (other), and  $V_{IL} = 0\text{ V}$ , with all output pins unloaded and the on-chip MOS pull-up transistors in the off state.

\*4 The values are for  $V_{RAM} \leq V_{CC} < 3.0\text{ V}$ ,  $V_{IH\ min} = V_{CC} - 0.1\text{ V}$ , and  $V_{IL\ max} = 0.1\text{ V}$ .

\*5  $I_{CC}$  depends on  $V_{CC}$  and  $f$  as follows:

$$I_{CC\ max} = 1.0\text{ (mA)} + 0.93\text{ (mA/(MHz} \times \text{V))} \times V_{CC} \times f\text{ (normal operation)}$$

$$I_{CC\ max} = 1.0\text{ (mA)} + 0.77\text{ (mA/(MHz} \times \text{V))} \times V_{CC} \times f\text{ (sleep mode)}$$

\*6 The FWE pin is used only in the flash memory version.

\*7  $AV_{CC} = 3.3\text{ V}$  to 5.5 V if the A/D and D/A converters are not used (used as I/O ports).

\*8  $V_{ref} = 3.3\text{ V}$  to  $AV_{CC}$  if the A/D and D/A converters are not used (used as I/O ports).

**Table 25-3 Permissible Output Currents**

Conditions:  $V_{CC} = PLLV_{CC} = 3.0\text{ V to }3.6\text{ V}$ ,  $PV_{CC} = 3.0\text{ V to }5.5\text{ V}$ ,  $AV_{CC} = 3.6\text{ V to }5.5\text{ V}^{*1}$ ,  
 $V_{ref} = 3.6\text{ V to }AV_{CC}^{*2}$ ,  $V_{SS} = AV_{SS} = PLLV_{SS} = 0\text{ V}$ ,  $T_a = -20^\circ\text{C to }+75^\circ\text{C}$  (regular specifications),  $T_a = -40^\circ\text{C to }+85^\circ\text{C}$  (wide-range specifications)

Item			Symbol	Min	Typ	Max	Unit
Permissible output low current (per pin)	All output pins	$PV_{CC} = 3.0\text{ V to }5.5\text{ V}$	$I_{OL}$	—	—	10	mA
Permissible output low current (total)	Total of all output pins	$PV_{CC} = 3.0\text{ V to }5.5\text{ V}$	$\sum I_{OL}$	—	—	120	mA
Permissible output high current (per pin)	All output pins	$PV_{CC} = 3.0\text{ V to }5.5\text{ V}$	$-I_{OH}$	—	—	2.0	mA
Permissible output high current (total)	Total of all output pins	$PV_{CC} = 3.0\text{ V to }5.5\text{ V}$	$\sum -I_{OH}$	—	—	40	mA

Notes: To protect chip reliability, do not exceed the output current values in table 25-3.

\*1  $AV_{CC} = 3.3\text{ V to }5.5\text{ V}$  if A/D and D/A not used (pins used as I/O ports).

\*2  $V_{ref} = 3.3\text{ V to }AV_{CC}$  if A/D and D/A not used (pins used as I/O ports).



**Table 25-4 Bus Drive Characteristics**

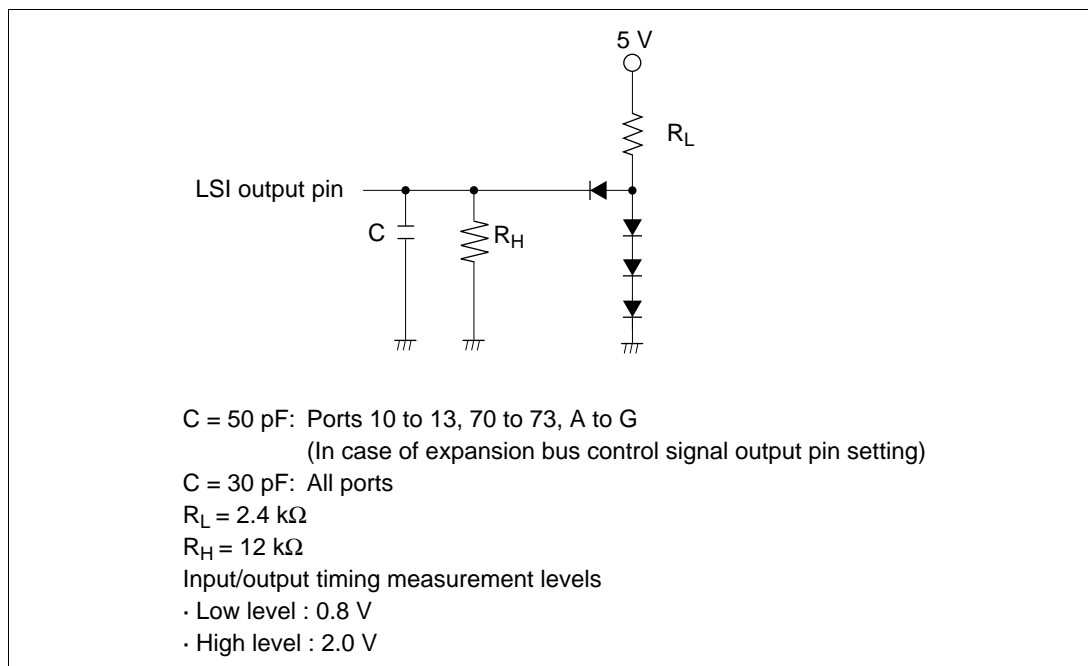
Condition :  $V_{CC} = PLLV_{CC} = 3.0\text{ V to }3.6\text{ V}$ ,  $PV_{CC} = 3.0\text{ V to }5.5\text{ V}$ ,  $AV_{CC} = 3.3\text{ V to }5.5\text{ V}$ ,  
 $V_{ref} = 3.3\text{ V to }AV_{CC}$ ,  $V_{SS} = AV_{SS} = PLLV_{SS} = 0\text{ V}$ ,  $T_a = -20^\circ\text{C to }+75^\circ\text{C}$  (regular specifications),  $T_a = -40^\circ\text{C to }+85^\circ\text{C}$  (wide-range specifications)

Applicable Pins: SCL1-0, SDA1-0

Item	Symbol	Min	Typ	Max	Unit	Test Conditions
Schmitt trigger	$V_{T-}$	$PV_{CC} \times 0.3$	—	—	V	
input voltage	$V_{T+}$	—	—	$PV_{CC} \times 0.7$		
	$V_{T+} - V_{T-}$	0.4	—	—		$PV_{CC} = 4.5\text{ V to }5.5\text{ V}$
		0.2	—	—		$PV_{CC} = 3.0\text{ V to }4.5\text{ V}$
Input high voltage	$V_{IH}$	$PV_{CC} \times 0.7$	—	$PV_{CC} + 0.5$	V	
Input low voltage	$V_{IL}$	- 0.5	—	$PV_{CC} \times 0.3$	V	
Output low voltage	$V_{OL}$	—	—	0.7	V	$I_{OL} = 8\text{ mA}$ , $PV_{CC} = 4.5\text{ V to }5.5\text{ V}$
		—	—	0.4		$I_{OL} = 3\text{ mA}$ , $PV_{CC} = 4.5\text{ V to }5.5\text{ V}$
		—	—	0.4		$I_{OL} = 1.6\text{ mA}$ , $PV_{CC} = 3.0\text{ V to }5.5\text{ V}$
Input capacitance	$C_{in}$	—	—	20	pF	$V_{in} = 0\text{ V}$ , $f = 1\text{ MHz}$ , $T_a = 25^\circ\text{C}$
Three-state leakage current (off state)	$ I_{TSI} $	—	—	1.0	$\mu\text{A}$	$V_{in} = 0.5\text{ V to }V_{CC} - 0.5\text{ V}$
SCL, SDA, output fall time	$t_{of}$	$20 + 0.1 C_b$	—	250	ns	

## 25.3 AC Characteristics

Figure 25-1 show, the test conditions for the AC characteristics.



**Figure 25-1 Output Load Circuit**

### 25.3.1 Clock Timing

Table 25-5 lists the clock timing

**Table 25-5 Clock Timing**

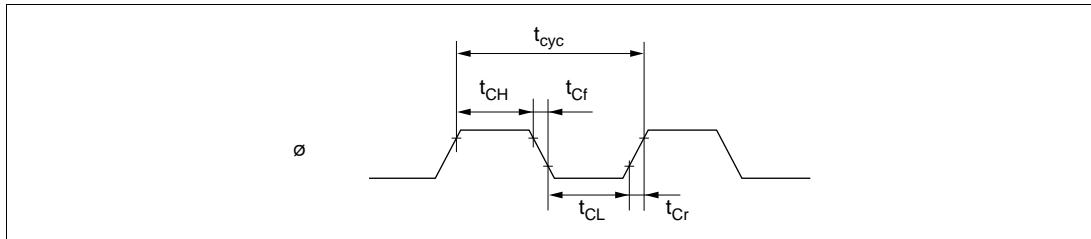
Condition A:  $V_{CC} = PLLV_{CC} = 3.0\text{ V to }3.6\text{ V}$ ,  $PV_{CC} = 3.0\text{ V to }5.5\text{ V}$ ,  $AV_{CC} = 3.6\text{ V to }5.5\text{ V}^{*1}$ ,  
 $V_{ref} = 3.6\text{ V to }AV_{CC}^{*2}$ ,  $V_{SS} = AV_{SS} = PLLV_{SS} = 0\text{ V}$ ,  $\phi = 32.768\text{ kHz}$ , 2 to 16 MHz,  
 $T_a = -20^\circ\text{C to }+75^\circ\text{C}$  (regular specifications),  $T_a = -40^\circ\text{C to }+85^\circ\text{C}$  (wide-range specifications)

Condition B:  $V_{CC} = PLLV_{CC} = 3.0\text{ V to }3.6\text{ V}$ ,  $PV_{CC} = 4.5\text{ V to }5.5\text{ V}$ ,  $AV_{CC} = 4.5\text{ V to }5.5\text{ V}$ ,  
 $V_{ref} = 4.5\text{ V to }AV_{CC}$ ,  $V_{SS} = AV_{SS} = PLLV_{SS} = 0\text{ V}$ ,  $\phi = 32.768\text{ kHz}$ , 2 to 25 MHz,  
 $T_a = -20^\circ\text{C to }+75^\circ\text{C}$  (regular specifications),  $T_a = -40^\circ\text{C to }+85^\circ\text{C}$  (wide-range specifications)

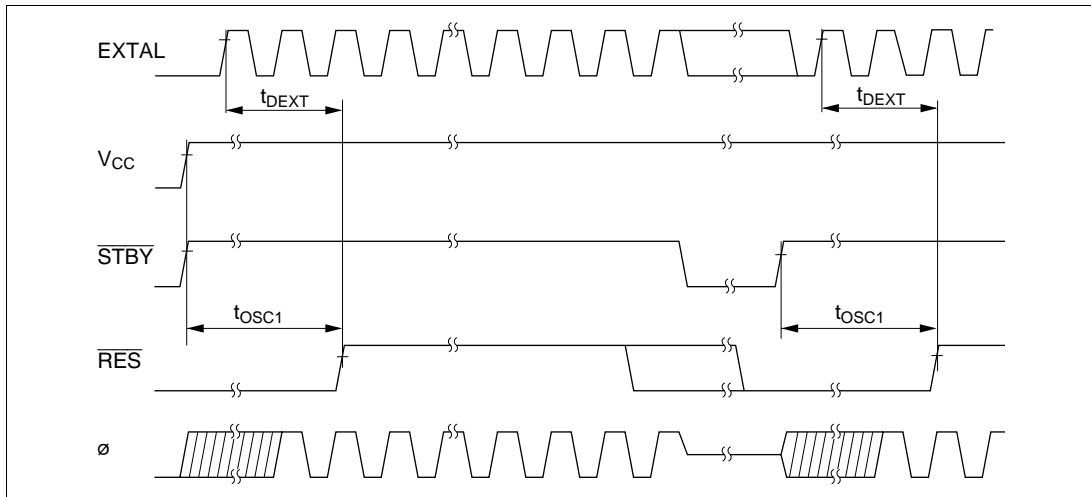
Item	Symbol	Condition A		Condition B		Unit	Test Conditions
		16MHz		25MHz			
		Min	Max	Min	Max		
Clock cycle time	$t_{cyc}$	62.5	500	40	500	ns	Figure 25-2
Clock high pulse width	$t_{CH}$	18	—	15	—	ns	
Clock low pulse width	$t_{CL}$	18	—	15	—	ns	
Clock rise time	$t_{Cr}$	—	12	—	5	ns	
Clock fall time	$t_{Cf}$	—	12	—	5	ns	
Clock oscillator settling time at reset (crystal)	$t_{OSC1}$	10	—	20	—	ms	Figure 25-3
Clock oscillator settling time in software standby (crystal)	$t_{OSC2}$	8	—	10	—	ms	Figure 24-3
External clock output stabilization delay time	$t_{DEXT}$	2	—	2	—	ms	Figure 25-3
32 kHz clock oscillation settling time	$t_{OSC3}$	—	2	—	2	s	
Sub clock oscillator frequency	$f_{SUB}$	32.768		32.768		kHz	
Sub clock ( $\phi_{SUB}$ ) cycle time	$t_{SUB}$	30.5		30.5		$\mu\text{s}$	

Notes: \*1  $AV_{CC} = 3.3\text{ V to }5.5\text{ V}$  if A/D and D/A not used (pins used as I/O ports).

\*2  $V_{ref} = 3.3\text{ V to }AV_{CC}$  if A/D and D/A not used (pins used as I/O ports).



**Figure 25-2 System Clock Timing**



**Figure 25-3 Oscillator Settling Timing**

### 25.3.2 Control Signal Timing

Table 25-6 lists the control signal timing.

**Table 25-6 Control Signal Timing**

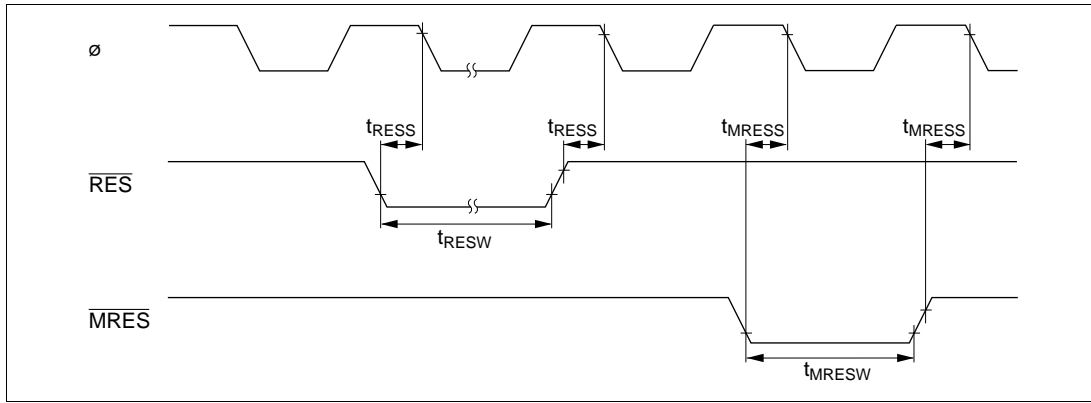
Condition A:  $V_{CC} = PLLV_{CC} = 3.0\text{ V to }3.6\text{ V}$ ,  $PV_{CC} = 3.0\text{ V to }5.5\text{ V}$ ,  $AV_{CC} = 3.6\text{ V to }5.5\text{ V}^{*1}$ ,  
 $V_{ref} = 3.6\text{ V to }AV_{CC}^{*2}$ ,  $V_{SS} = AV_{SS} = PLLV_{SS} = 0\text{ V}$ ,  $\phi = 32.768\text{ kHz}$ , 2 to 16 MHz,  
 $T_a = -20^\circ\text{C to }+75^\circ\text{C}$  (regular specifications),  $T_a = -40^\circ\text{C to }+85^\circ\text{C}$  (wide-range specifications)

Condition B:  $V_{CC} = PLLV_{CC} = 3.0\text{ V to }3.6\text{ V}$ ,  $PV_{CC} = 4.5\text{ V to }5.5\text{ V}$ ,  $AV_{CC} = 4.5\text{ V to }5.5\text{ V}$ ,  
 $V_{ref} = 4.5\text{ V to }AV_{CC}$ ,  $V_{SS} = AV_{SS} = PLLV_{SS} = 0\text{ V}$ ,  $\phi = 32.768\text{ kHz}$ , 2 to 25 MHz,  
 $T_a = -20^\circ\text{C to }+75^\circ\text{C}$  (regular specifications),  $T_a = -40^\circ\text{C to }+85^\circ\text{C}$  (wide-range specifications)

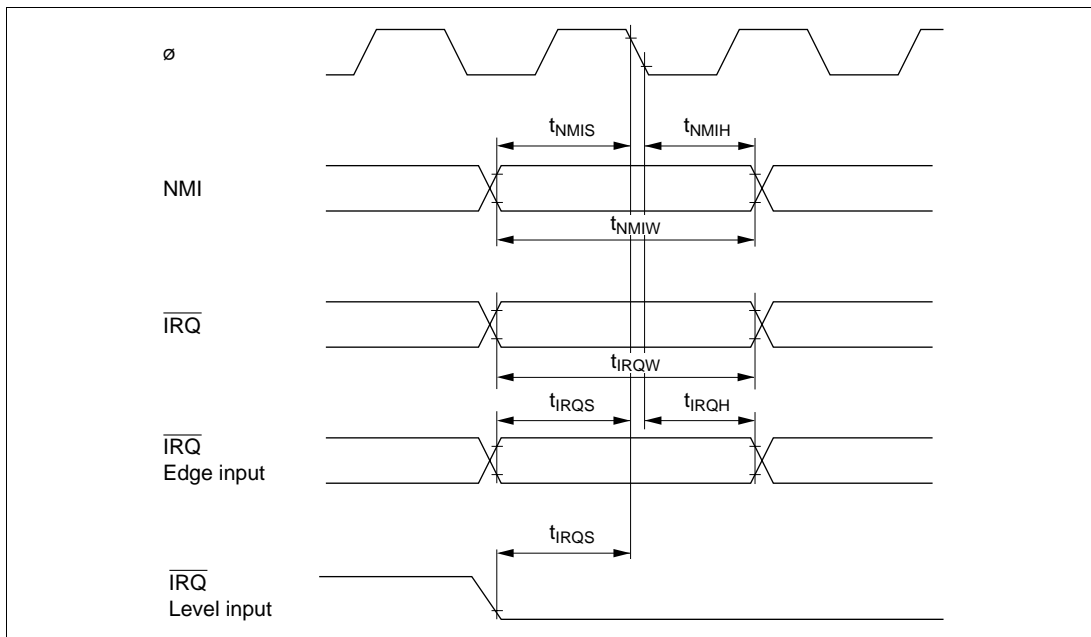
Item	Symbol	Condition A		Condition B		Unit	Test Conditions
		Min	Max	Min	Max		
$\overline{RES}$ setup time	$t_{RESS}$	200	—	200	—	ns	Figure 25-4
$\overline{RES}$ pulse width	$t_{RESW}$	20	—	20	—	$t_{cyc}$	
$\overline{MRES}$ setup time	$t_{MRESS}$	250	—	250	—	ns	
$\overline{MRES}$ pulse width	$t_{MRESW}$	20	—	20	—	$t_{cyc}$	
NMI setup time	$t_{NMIS}$	250	—	150	—	ns	Figure 25-5
NMI hold time	$t_{NMIH}$	10	—	10	—		
NMI pulse width (exiting software standby mode)	$t_{NMIW}$	200	—	200	—	ns	
$\overline{IRQ}$ setup time	$t_{IRQS}$	250	—	150	—	ns	
$\overline{IRQ}$ hold time	$t_{IRQH}$	10	—	10	—	ns	
$\overline{IRQ}$ pulse width (exiting software standby mode)	$t_{IRQW}$	200	—	200	—	ns	

Notes: \*1  $AV_{CC} = 3.3\text{ V to }5.5\text{ V}$  if A/D and D/A not used (pins used as I/O ports).

\*2  $V_{ref} = 3.3\text{ V to }AV_{CC}$  if A/D and D/A not used (pins used as I/O ports).



**Figure 25-4 Reset Input Timing**



**Figure 25-5 Interrupt Input Timing**

### 25.3.3 Bus Timing

Table 25-7 lists the bus timing.

**Table 25-7 Bus Timing**

Condition A:  $V_{CC} = PLLV_{CC} = 3.0\text{ V to }3.6\text{ V}$ ,  $PV_{CC} = 3.0\text{ V to }5.5\text{ V}$ ,  $AV_{CC} = 3.6\text{ V to }5.5\text{ V}^{*1}$ ,  
 $V_{ref} = 3.6\text{ V to }AV_{CC}^{*2}$ ,  $V_{SS} = AV_{SS} = PLLV_{SS} = 0\text{ V}$ ,  $\phi = 2\text{ to }16\text{ MHz}$ ,  $T_a = -20^\circ\text{C}$   
to  $+75^\circ\text{C}$  (regular specifications),  $T_a = -40^\circ\text{C to }+85^\circ\text{C}$  (wide-range specifications)

Condition B:  $V_{CC} = PLLV_{CC} = 3.0\text{ V to }3.6\text{ V}$ ,  $PV_{CC} = 4.5\text{ V to }5.5\text{ V}$ ,  $AV_{CC} = 4.5\text{ V to }5.5\text{ V}$ ,  
 $V_{ref} = 4.5\text{ V to }AV_{CC}$ ,  $V_{SS} = AV_{SS} = PLLV_{SS} = 0\text{ V}$ ,  $\phi = 2\text{ to }25\text{ MHz}$ ,  $T_a = -20^\circ\text{C}$   
to  $+75^\circ\text{C}$  (regular specifications),  $T_a = -40^\circ\text{C to }+85^\circ\text{C}$  (wide-range specifications)

Item	Symbol	Condition A		Condition B		Unit	Test Conditions
		Min	Max	Min	Max		
Address delay time	$t_{AD}$	—	30	—	20	ns	Figure 25-6 to
Address setup time	$t_{AS}$	$0.5 \times$ $t_{cyc} - 30$	—	$0.5 \times$ $t_{cyc} - 15$	—	ns	figure 25-11
Address hold time	$t_{AH}$	$0.5 \times$ $t_{cyc} - 20$	—	$0.5 \times$ $t_{cyc} - 8$	—	ns	
$\overline{CS}$ delay time 1	$t_{CSD1}$	—	30	—	20	ns	
$\overline{CS}$ delay time 2	$t_{CSD2}$	—	30	—	18	ns	
$\overline{AS}$ delay time	$t_{ASD}$	—	30	—	18	ns	
$\overline{RD}$ delay time 1	$t_{RSD1}$	—	30	—	18	ns	
$\overline{RD}$ delay time 2	$t_{RSD2}$	—	30	—	18	ns	
Read data setup time	$t_{RDS}$	30	—	15	—	ns	
Read data hold time	$t_{RDH}$	0	—	0	—	ns	
Read data access time1	$t_{ACC1}$	—	$1.0 \times$ $t_{cyc} - 35$	—	$1.0 \times$ $t_{cyc} - 25$	ns	
Read data access time2	$t_{ACC2}$	—	$1.5 \times$ $t_{cyc} - 35$	—	$1.5 \times$ $t_{cyc} - 25$	ns	
Read data access time3	$t_{ACC3}$	—	$2.0 \times$ $t_{cyc} - 35$	—	$2.0 \times$ $t_{cyc} - 25$	ns	
Read data access time 4	$t_{ACC4}$	—	$2.5 \times$ $t_{cyc} - 35$	—	$2.5 \times$ $t_{cyc} - 25$	ns	

Item	Symbol	Condition A		Condition B		Unit	Test Conditions
		Min	Max	Min	Max		
Read data access time 5	$t_{ACC5}$	—	$3.0 \times t_{cyc} - 35$	—	$3.0 \times t_{cyc} - 25$	ns	Figure 25-6 to figure 25-11
$\overline{WR}$ delay time 1	$t_{WRD1}$	—	30	—	18	ns	
$\overline{WR}$ delay time 2	$t_{WRD2}$	—	30	—	18	ns	
$\overline{WR}$ pulse width 1	$t_{WSW1}$	$1.0 \times t_{cyc} - 30$	—	$1.0 \times t_{cyc} - 15$	—	ns	
$\overline{WR}$ pulse width 2	$t_{WSW2}$	$1.5 \times t_{cyc} - 30$	—	$1.5 \times t_{cyc} - 15$	—	ns	
Write data delay time	$t_{WDD}$	—	30	—	22	ns	
Write data setup time	$t_{WDS}$	$0.5 \times t_{cyc} - 27$	—	$0.5 \times t_{cyc} - 15$	—	ns	
Write data hold time	$t_{WDH}$	$0.5 \times t_{cyc} - 20$	—	$0.5 \times t_{cyc} - 8$	—	ns	
$\overline{WR}$ setup time	$t_{WCS}$	$0.5 \times t_{cyc} - 15$	—	$0.5 \times t_{cyc} - 10$	—	ns	
$\overline{WR}$ hold time	$t_{WCH}$	$0.5 \times t_{cyc} - 15$	—	$0.5 \times t_{cyc} - 10$	—	ns	
$\overline{RAS}$ precharge time	$t_{PCH}$	$1.5 \times t_{cyc} - 30$	—	$1.5 \times t_{cyc} - 15$	—	ns	Figure 25-11 to figure 25-13
$\overline{CAS}$ precharge time1	$t_{CP1}$	$1.0 \times t_{cyc} - 20$	—	$1.0 \times t_{cyc} - 8$	—	ns	
$\overline{CAS}$ precharge time2	$t_{CP2}$	$0.5 \times t_{cyc} - 20$	—	$0.5 \times t_{cyc} - 8$	—	ns	
$\overline{CAS}$ delay time1	$t_{CASD1}$	—	30	—	20	ns	
$\overline{CAS}$ delay time2	$t_{CASD2}$	—	30	—	18	ns	
$\overline{OE}$ delay time1	$t_{OED1}$	—	30	—	18	ns	
$\overline{OE}$ delay time2	$t_{OED2}$	—	30	—	18	ns	
$\overline{CAS}$ setup time	$t_{CSR}$	$0.5 \times t_{cyc} - 25$	—	$0.5 \times t_{cyc} - 8$	—	ns	
$\overline{WAIT}$ setup time	$t_{WTS}$	40	—	25	—	ns	Figure 25-8
$\overline{WAIT}$ hold time	$t_{WTH}$	10	—	5	—	ns	
$\overline{BREQ}$ setup time	$t_{BRQS}$	60	—	30	—	ns	Figure 25-14
$\overline{BACK}$ delay time	$t_{BACD}$	—	30	—	15	ns	
Bus-floating time	$t_{BZD}$	—	60	—	40	ns	
$\overline{BREQO}$ delay time	$t_{BRQOD}$	—	40	—	25	ns	Figure 25-15

Notes: \*1  $AV_{CC} = 3.3 \text{ V to } 5.5 \text{ V}$  if A/D and D/A not used (pins used as I/O ports).

\*2  $V_{ref} = 3.3 \text{ V to } AV_{CC}$  if A/D and D/A not used (pins used as I/O ports).



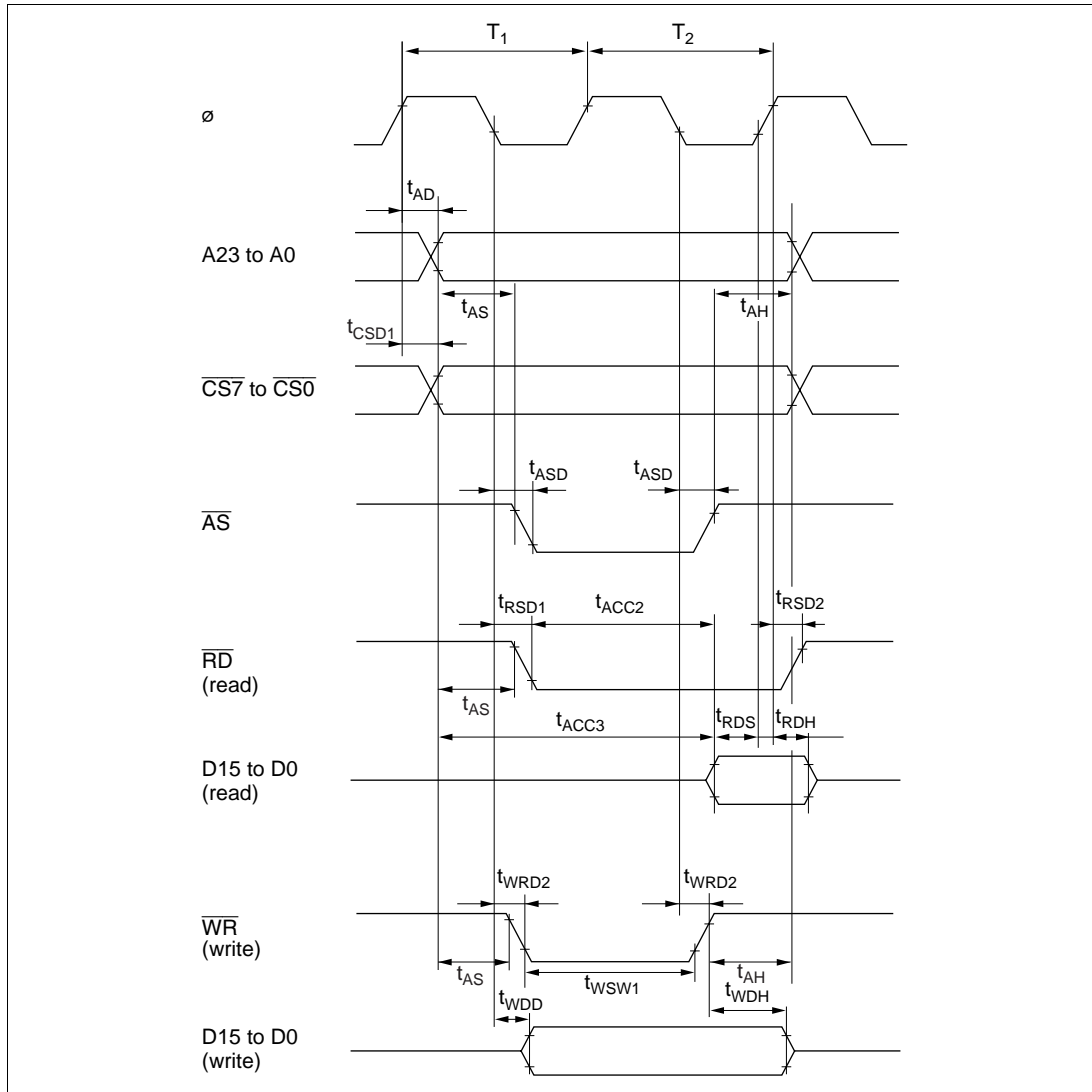


Figure 25-6 Basic Bus Timing (Two-State Access)

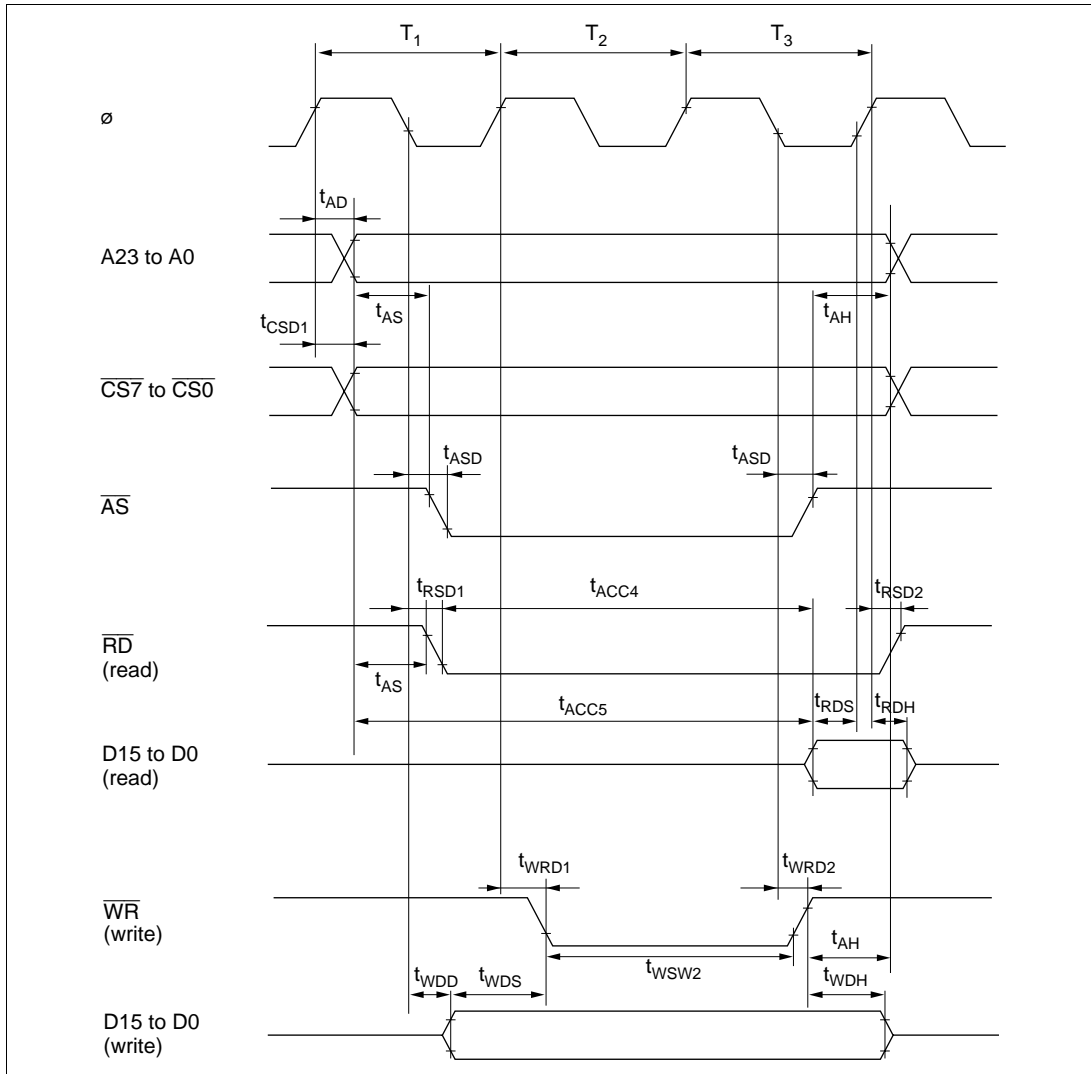
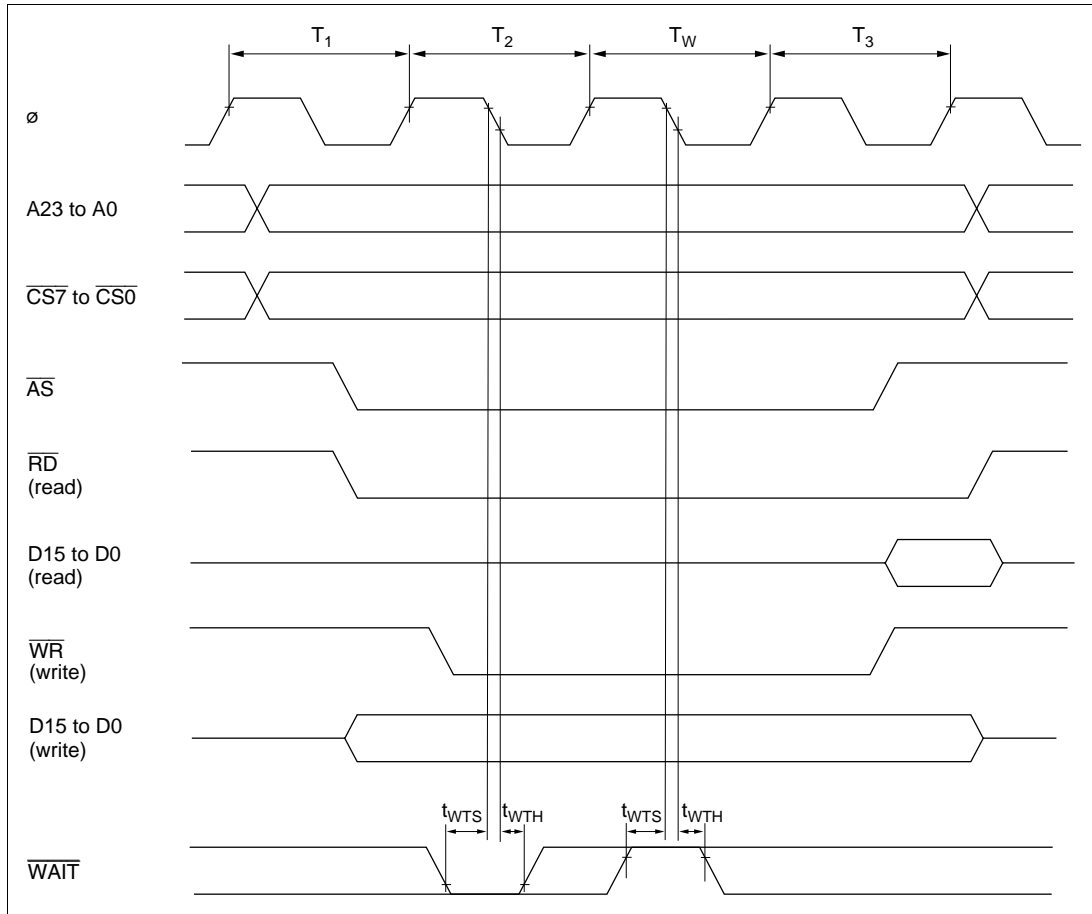
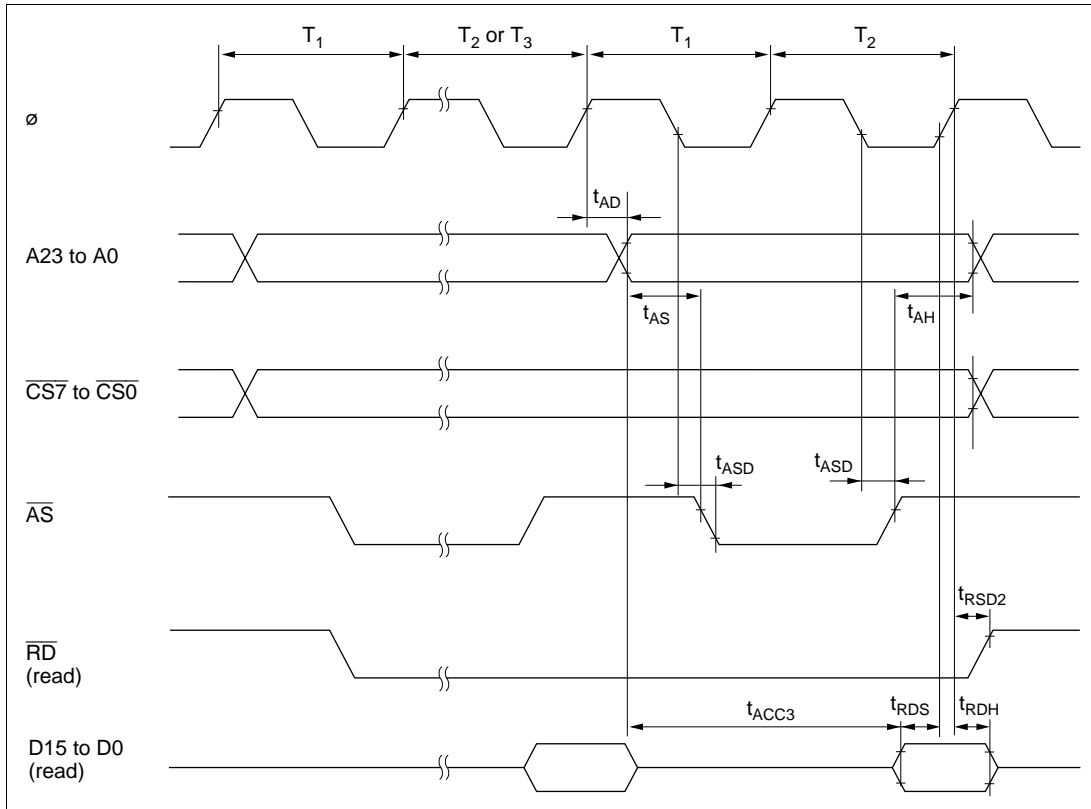


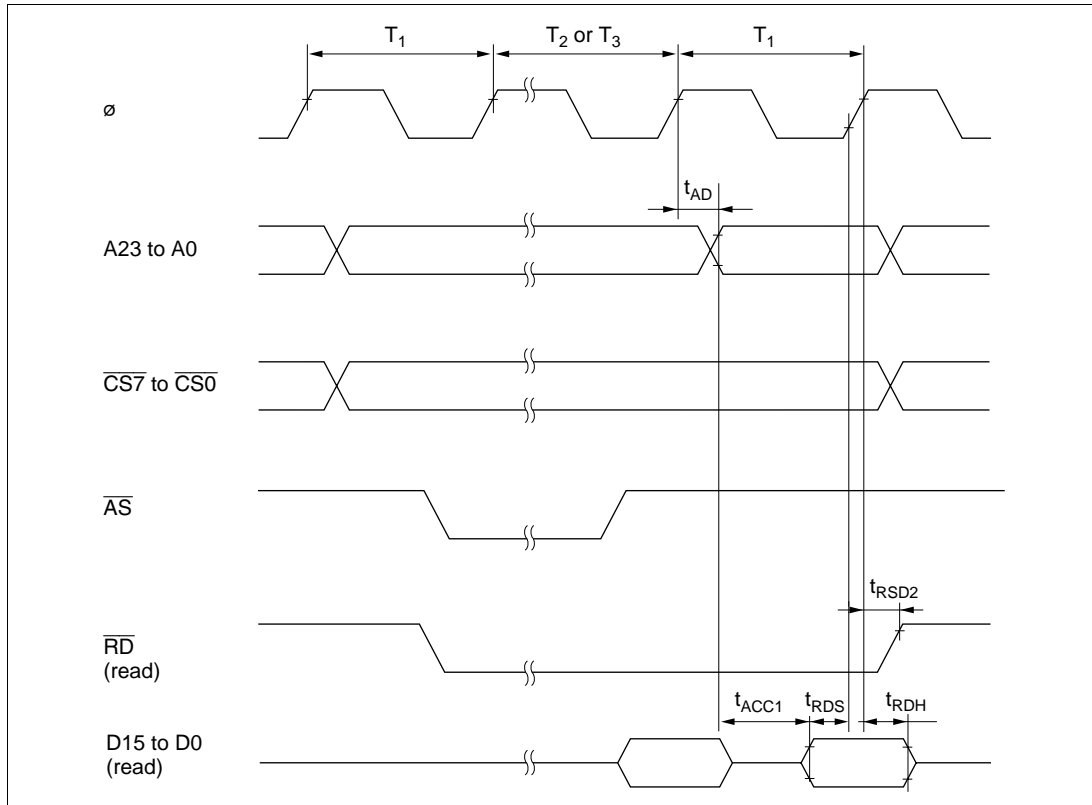
Figure 25-7 Basic Bus Timing (Three-State Access)



**Figure 25-8 Basic Bus Timing (Three-State Access with One Wait State)**



**Figure 25-9 Burst ROM Access Timing (Two-State Access)**



**Figure 25-10 Burst ROM Access Timing (One-State Access)**

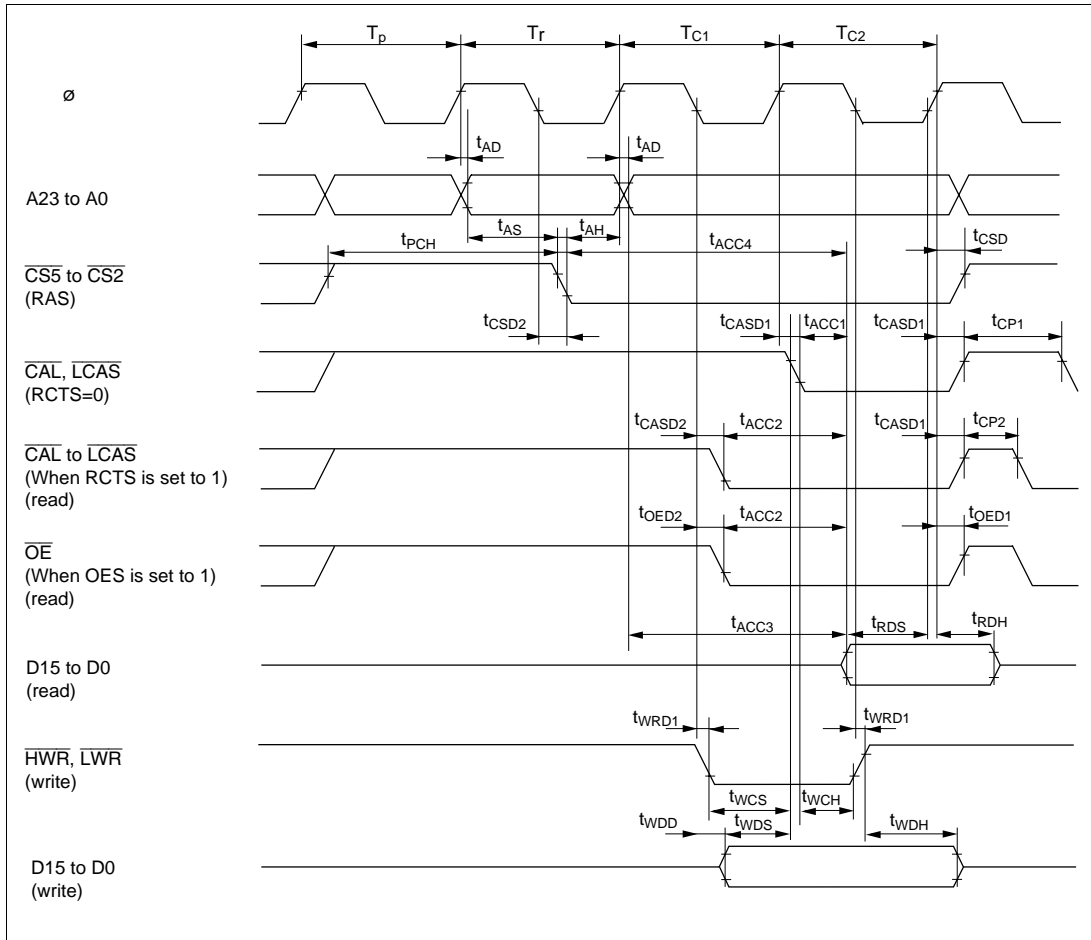


Figure 25-11 DRAM Access Timing

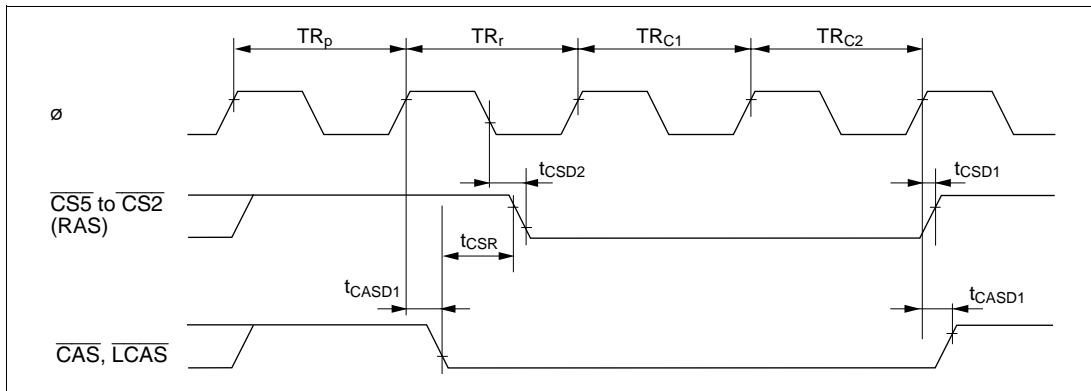


Figure 25-12 DRAM CBR Refresh Timing

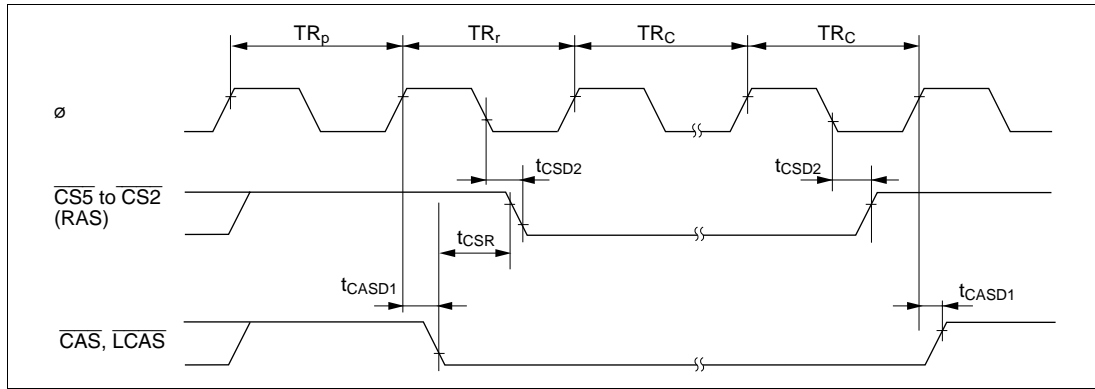


Figure 25-13 DRAM Self-Refresh Timing

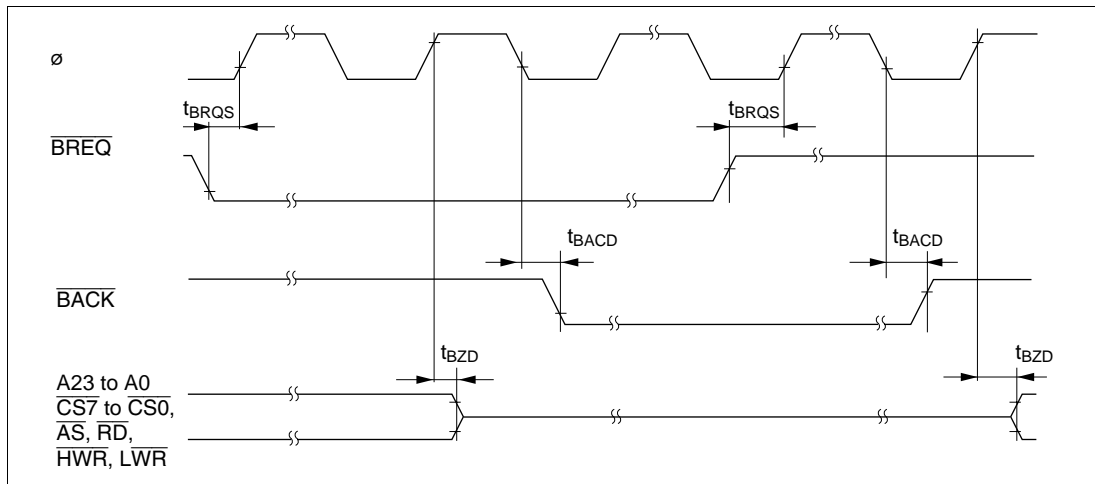


Figure 25-14 External Bus Release Timing

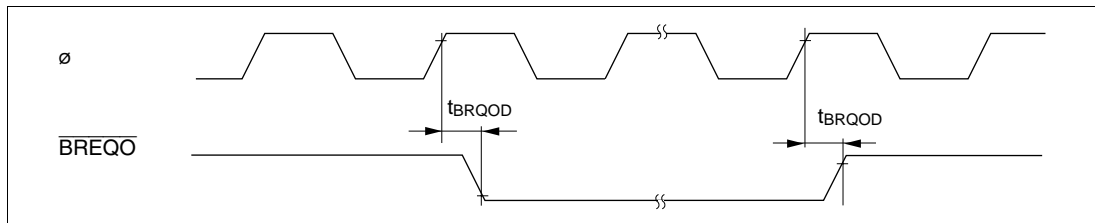


Figure 25-15 External Bus Request Output Timing

### 25.3.4 DMAC Timing

Table 25-8 shows the DMAC timing.

**Table 25-8 DMAC Timing**

Condition A:  $V_{CC} = PLLV_{CC} = 3.0\text{ V to }3.6\text{ V}$ ,  $PV_{CC} = 3.0\text{ V to }5.5\text{ V}$ ,  $AV_{CC} = 3.6\text{ V to }5.5\text{ V}^{*1}$ ,  
 $V_{ref} = 3.6\text{ V to }AV_{CC}^{*2}$ ,  $V_{SS} = AV_{SS} = PLLV_{SS} = 0\text{ V}$ ,  $\phi = 2\text{ to }16\text{ MHz}$ ,  $T_a = -20^\circ\text{C}$   
to  $+75^\circ\text{C}$  (regular specifications),  $T_a = -40^\circ\text{C to }+85^\circ\text{C}$  (wide-range specifications)

Condition B:  $V_{CC} = PLLV_{CC} = 3.0\text{ V to }3.6\text{ V}$ ,  $PV_{CC} = 4.5\text{ V to }5.5\text{ V}$ ,  $AV_{CC} = 4.5\text{ V to }5.5\text{ V}$ ,  
 $V_{ref} = 4.5\text{ V to }AV_{CC}$ ,  $V_{SS} = AV_{SS} = PLLV_{SS} = 0\text{ V}$ ,  $\phi = 2\text{ to }25\text{ MHz}$ ,  $T_a = -20^\circ\text{C}$  to  
 $+75^\circ\text{C}$  (regular specifications),  $T_a = -40^\circ\text{C to }+85^\circ\text{C}$  (wide-range specifications)

Item	Symbol	Condition A		Condition B		Unit	Test Conditions
		Min	Max	Min	Max		
$\overline{DREQ}$ setup time	$t_{DRQS}$	40	—	25	—	ns	Figure 25-19
$\overline{DREQ}$ hold time	$t_{DRQH}$	10	—	10	—		
$\overline{TEND}$ delay time	$t_{TED}$	—	30	—	20		Figure 25-18
$\overline{DACK}$ delay time1	$t_{DACD1}$	—	30	—	18	ns	Figure 25-16,
$\overline{DACK}$ delay time2	$t_{DACD2}$	—	30	—	18		figure 25-17

Notes: \*1  $AV_{CC} = 3.3\text{ V to }5.5\text{ V}$  if A/D and D/A not used (pins used as I/O ports).

\*2  $V_{ref} = 3.3\text{ V to }AV_{CC}$  if A/D and D/A not used (pins used as I/O ports).



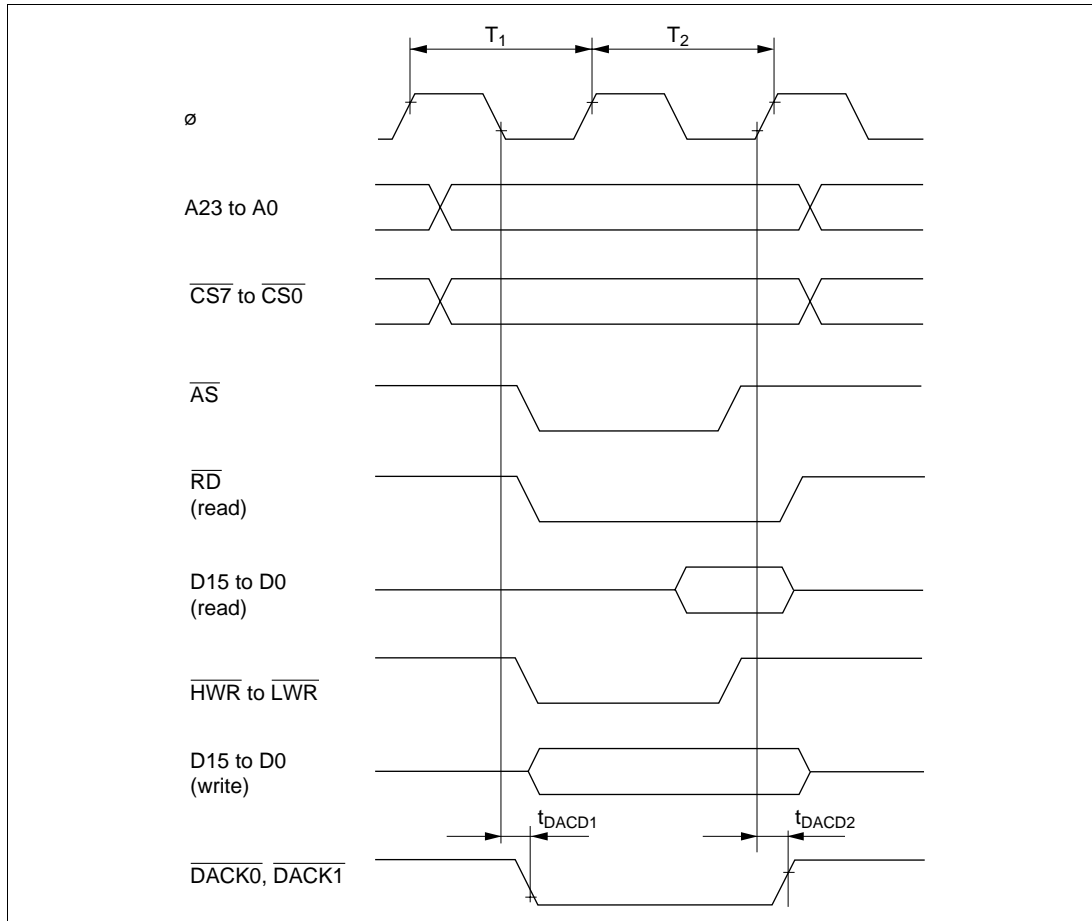
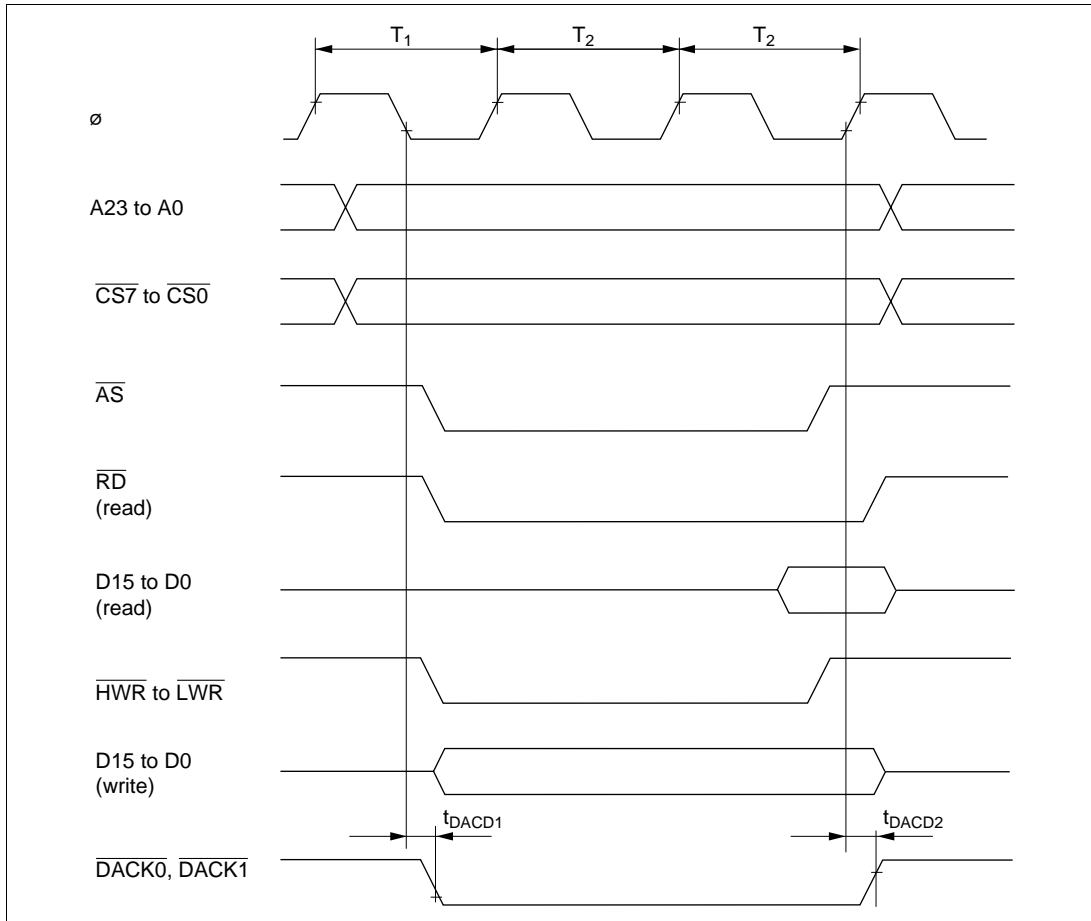
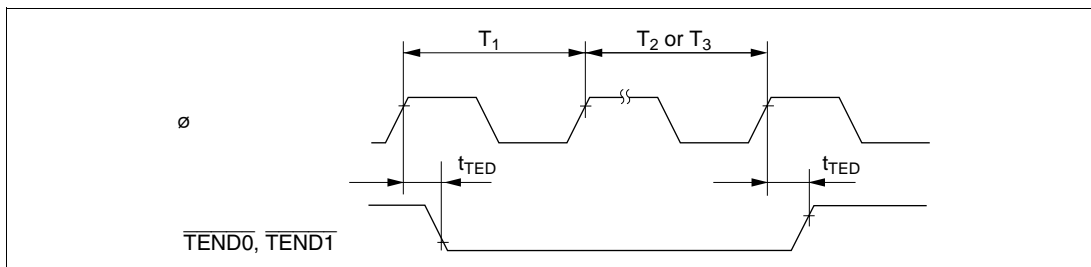


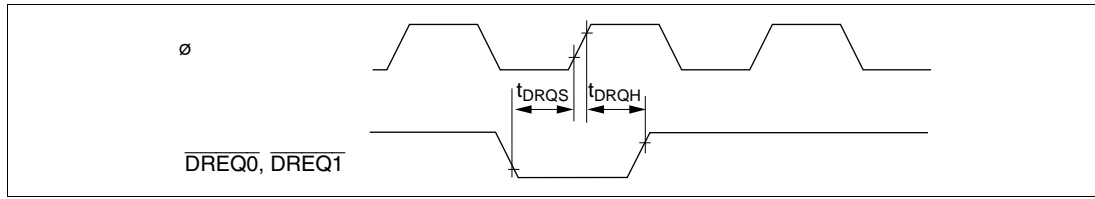
Figure 25-16 DMAC Single Address Transfer Timing / Two-State Access



**Figure 25-17 DMAC Single Address Transfer Timing / Three-State Access**



**Figure 25-18 DMAC TEND Output Timing**



**Figure 25-19 DMAC DREQ Input Timing**

### 25.3.5 Timing of On-Chip Supporting Modules

Table 25-9 lists the timing of on-chip supporting modules.

**Table 25-9 Timing of On-Chip Supporting Modules**

Condition A:  $V_{CC} = PLLV_{CC} = 3.0\text{ V to }3.6\text{ V}$ ,  $PV_{CC} = 3.0\text{ V to }5.5\text{ V}$ ,  $AV_{CC} = 3.6\text{ V to }5.5\text{ V}^{*1}$ ,  
 $V_{ref} = 3.6\text{ V to }AV_{CC}^{*2}$ ,  $V_{SS} = AV_{SS} = PLLV_{SS} = 0\text{ V}$ ,  $\phi = 32.768\text{ kHz}^{*3}$ ,  
 2 to 16 MHz,  $T_a = -20^\circ\text{C to }+75^\circ\text{C}$  (regular specifications),  $T_a = -40^\circ\text{C to }+85^\circ\text{C}$   
 (wide-range specifications)

Condition B:  $V_{CC} = PLLV_{CC} = 3.0\text{ V to }3.6\text{ V}$ ,  $PV_{CC} = 4.5\text{ V to }5.5\text{ V}$ ,  $AV_{CC} = 4.5\text{ V to }5.5\text{ V}$ ,  
 $V_{ref} = 4.5\text{ V to }AV_{CC}$ ,  $V_{SS} = AV_{SS} = PLLV_{SS} = 0\text{ V}$ ,  $\phi = 32.768\text{ kHz}^{*3}$ ,  
 2 to 25 MHz,  $T_a = -20^\circ\text{C to }+75^\circ\text{C}$  (regular specifications),  $T_a = -40^\circ\text{C to }+85^\circ\text{C}$   
 (wide-range specifications)

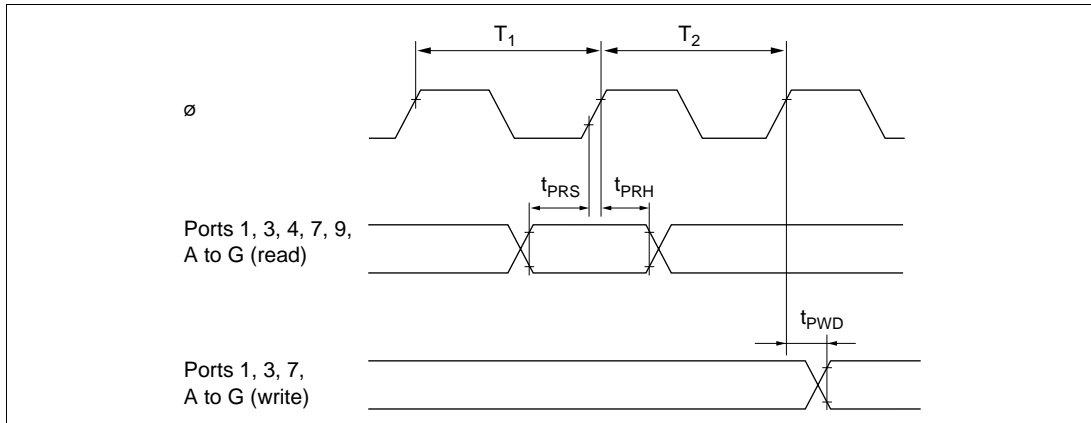
Item	Symbol	Condition A		Condition B		Unit	Test Conditions	
		Min	Max	Min	Max			
I/O port	Output data delay time	$t_{PWD}$	—	60	—	40	ns	Figure 25-20
	Input data setup time	$t_{PRS}$	40	—	25	—		
	Input data hold time	$t_{PRH}$	40	—	25	—		
PPG	Pulse output delay time	$t_{POD}$	—	60	—	40	ns	Figure 25-21
TPU	Timer output delay time	$t_{TOCD}$	—	60	—	40	ns	Figure 25-22
	Timer input setup time	$t_{TICS}$	40	—	25	—		
	Timer clock input setup time	$t_{TCKS}$	40	—	25	—	ns	Figure 25-23
	Timer clock pulse width	Single edge	$t_{TCKWH}$	1.5	—	1.5	—	$t_{cyc}$
Both edges		$t_{TCKWL}$	2.5	—	2.5	—		

Item	Symbol	Condition A		Condition B		Unit	Test Conditions		
		Min	Max	Min	Max				
TMR	Timer output delay time	$t_{TMOD}$	—	60	—	40	ns	Figure 25-24	
	Timer reset input setup time	$t_{TMRS}$	40	—	25	—	ns	Figure 25-26	
	Timer clock input setup time	$t_{TMCS}$	40	—	25	—	ns	Figure 25-25	
	Timer clock pulse width	Single edge	$t_{TMCWH}$	1.5	—	1.5	—	$t_{cyc}$	
		Both edges	$t_{TMCWL}$	2.5	—	2.5	—		
WDT0	Overflow output delay time	$t_{WOVD}$	—	60	—	40	ns	Figure 25-27	
WDT1	Buzz output delay time	$t_{BUZD}$	—	60	—	40	ns	Figure 25-28	
PWM	Pulse output delay time	$t_{PWOD}$	—	60	—	40	ns	Figure 25-29	
SCI	Input clock cycle	Asynchronous	$t_{Scyc}$	4	—	4	—	$t_{cyc}$	Figure 25-30
		Synchronous		6	—	6	—		
	Input clock pulse width	$t_{SCKW}$	0.4	0.6	0.4	0.6	$t_{Scyc}$		
	Input clock rise time	$t_{SCKr}$	—	1.5	—	1.5	$t_{cyc}$		
	Input clock fall time	$t_{SCKf}$	—	1.5	—	1.5			
	Transmit data delay time	$t_{TXD}$	—	60	—	40	ns	Figure 25-31	
	Receive data setup time (synchronous)	$t_{RXS}$	60	—	40	—			
	Receive data hold time (synchronous)	$t_{RXH}$	60	—	40	—			
A/D converter	Trigger input setup time	$t_{TRGS}$	60	—	40	—	ns	Figure 25-32	

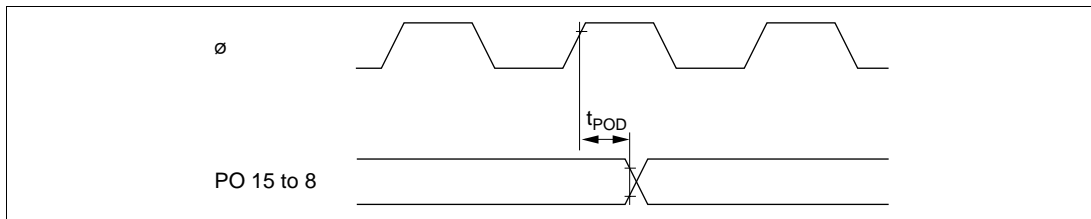
Notes: \*1  $AV_{CC} = 3.3\text{ V}$  to  $5.5\text{ V}$  if A/D and D/A not used (pins used as I/O ports).

\*2  $V_{ref} = 3.3\text{ V}$  to  $AV_{CC}$  if A/D and D/A not used (pins used as I/O ports).

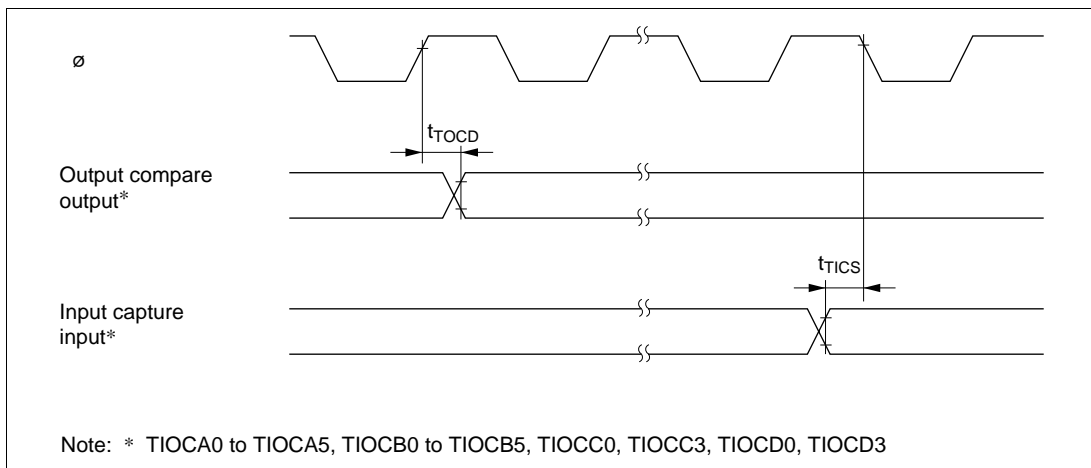
\*3 Only available I/O port, TMR, WDT0, and WDT1.



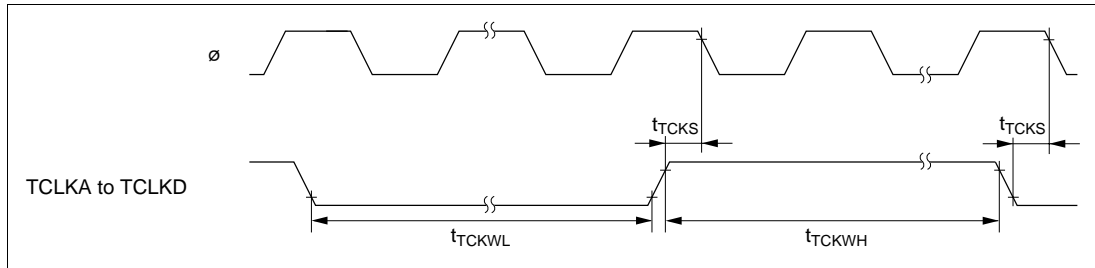
**Figure 25-20 I/O Port Input/Output Timing**



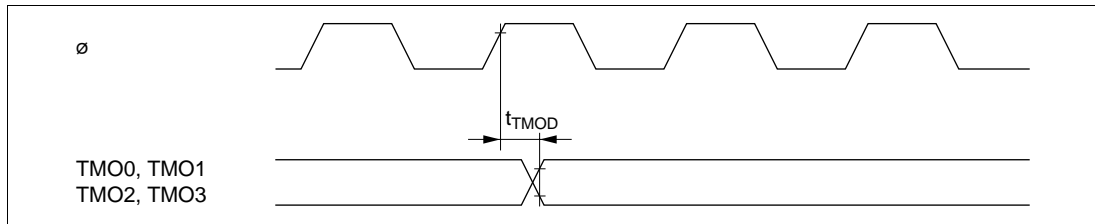
**Figure 25-21 PPG Output Timing**



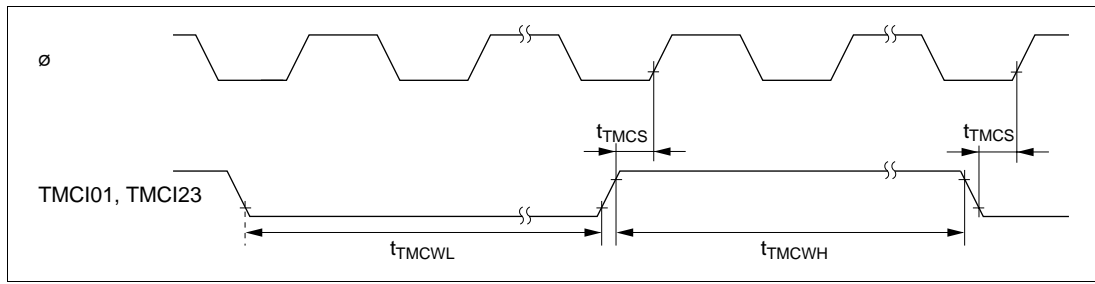
**Figure 25-22 TPU Input/Output Timing**



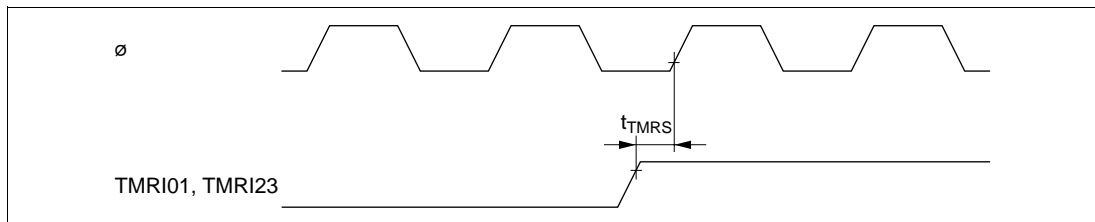
**Figure 25-23 TPU Clock Input Timing**



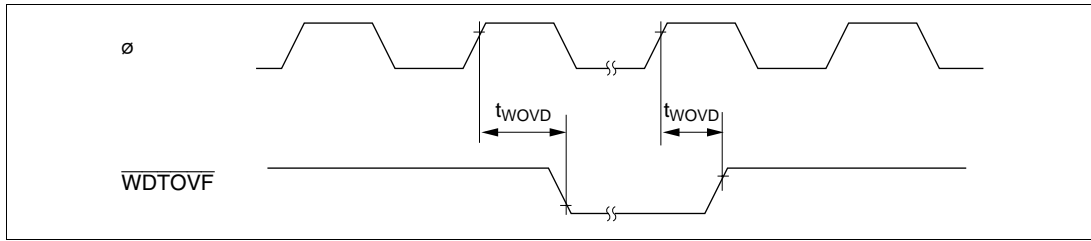
**Figure 25-24 8-bit Timer Output Timing**



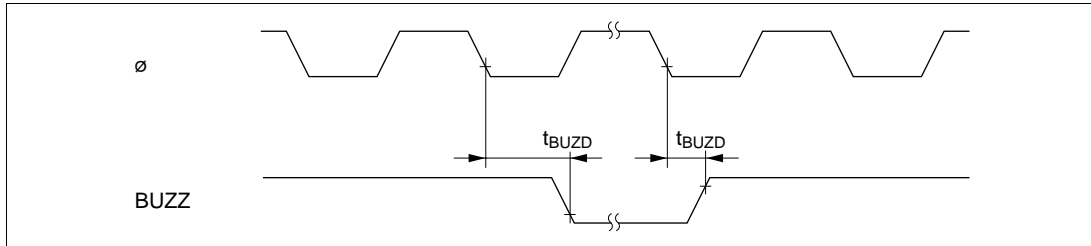
**Figure 25-25 8-bit Timer Clock Input Timing**



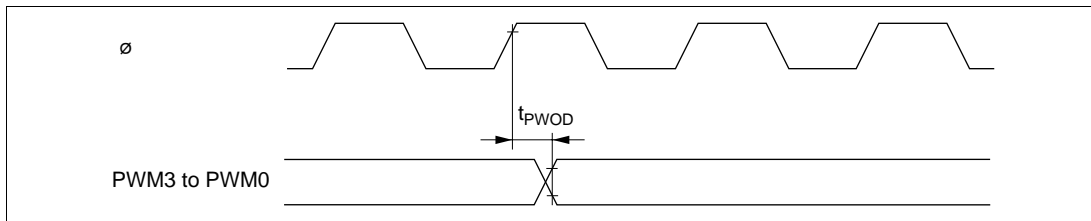
**Figure 25-26 8-bit Timer Reset Input Timing**



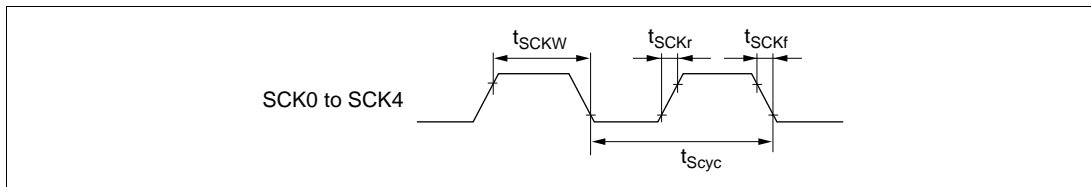
**Figure 25-27 WDT0 Output Timing**



**Figure 25-28 WDT1 Output Timing**

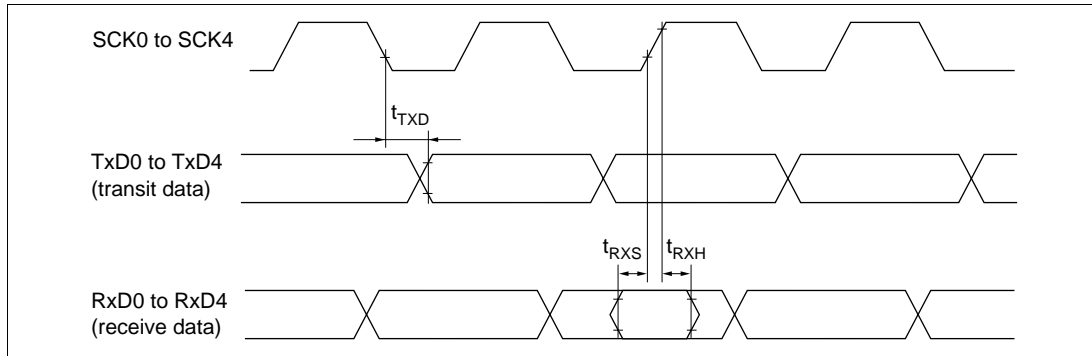


**Figure 25-29 PWM Output Timing**

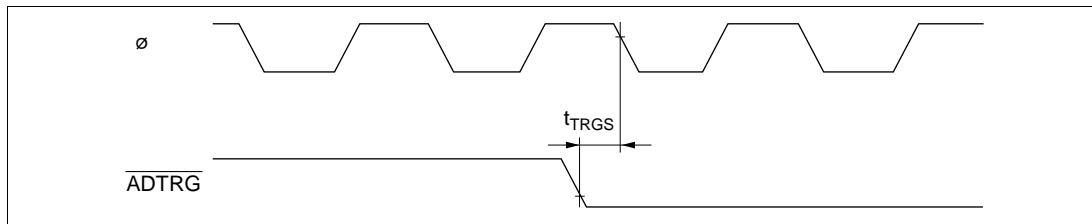


**Figure 25-30 SCK Clock Input Timing**





**Figure 25-31 SCI Input/Output Timing (Clock Synchronous Mode)**



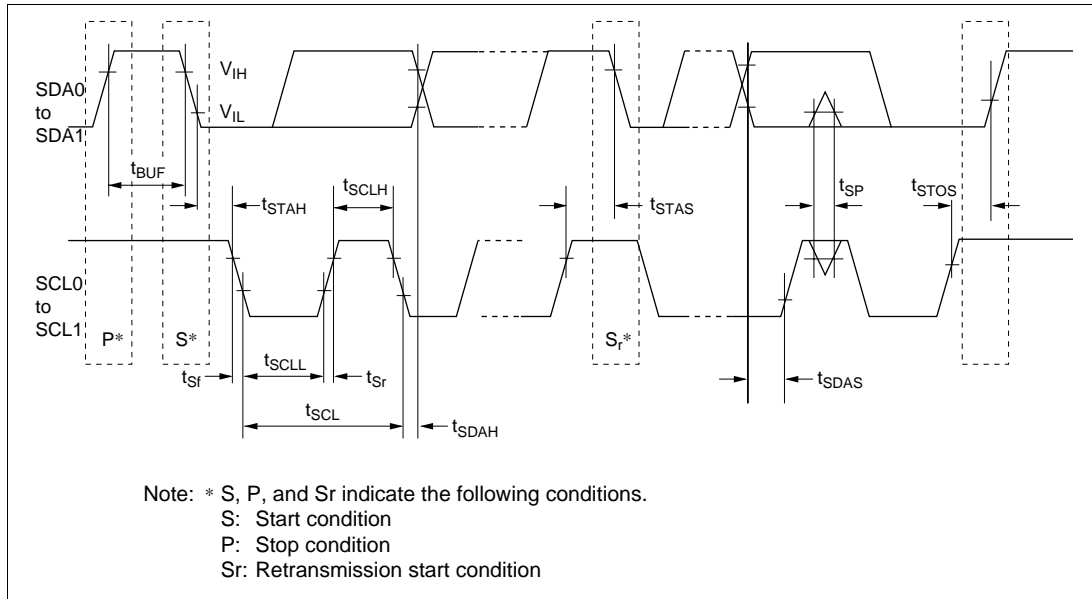
**Figure 25-32 A/D Converter External Trigger Input Timing**

**Table 25-10 I<sup>2</sup>C Bus Timing**

Conditions:  $V_{CC} = PLLV_{CC} = 3.0\text{ V to }3.6\text{ V}$ ,  $PV_{CC} = 3.0\text{ V to }5.5\text{ V}$ ,  $V_{SS} = AV_{SS} = PLLV_{SS} = 0\text{ V}$ ,  
 $\phi = 5\text{ MHz to maximum operating frequency}$ ,  $T_a = -20^\circ\text{C to }+75^\circ\text{C}$  (regular specifications),  $T_a = -40^\circ\text{C to }+85^\circ\text{C}$  (wide-range specifications)

Item	Symbol	Ratings			Unit	Notes
		Min	Typ	Max		
SCL input cycle time	$t_{SCL}$	$12t_{cyc}$	—	—	ns	Figure 25-33
SCL input high pulse width	$t_{SCLH}$	$3t_{cyc}$	—	—	ns	
SCL input low pulse width	$t_{SCLL}$	$5t_{cyc}$	—	—	ns	
SCL, SDA input rise time	$t_{Sr}$	—	—	$7.5t_{cyc}^*$	ns	
SCL, SDA input fall time	$t_{Sf}$	—	—	300	ns	
SCL, SDA input spike pulse elimination time	$t_{SP}$	—	—	$1t_{cyc}$	ns	
SDA input bus free time	$t_{BUF}$	$5t_{cyc}$	—	—	ns	
Start condition input hold time	$t_{STAH}$	$3t_{cyc}$	—	—	ns	
Retransmission start condition input setup time	$t_{STAS}$	$3t_{cyc}$	—	—	ns	
Stop condition input setup time	$t_{STOS}$	$3t_{cyc}$	—	—	ns	
Data input setup time	$t_{SDAS}$	$0.5t_{cyc}$	—	—	ns	
Data input hold time	$t_{SDAH}$	0	—	—	ns	
SCL, SDA capacitive load	$C_b$	—	—	400	pF	

Note: \*  $17.5t_{cyc}$  can be set according to the clock selected for use by the I<sup>2</sup>C module. For details, see section 18.4, Usage Notes.



**Figure 25-33 I<sup>2</sup>C Bus Interface Input/Output Timing (Option)**

## 25.4 A/D Conversion Characteristics

Table 25-11 lists the A/D conversion characteristics.

**Table 25-11 A/D Conversion Characteristics**

Condition A:  $V_{CC} = PLLV_{CC} = 3.0\text{ V to }3.6\text{ V}$ ,  $PV_{CC} = 3.0\text{ V to }5.5\text{ V}$ ,  
 $AV_{CC} = 3.6\text{ V to }5.5\text{ V}$ ,  $V_{ref} = 3.6\text{ V to }AV_{CC}$  if A/D and D/A used,  
 $AV_{CC} = 3.3\text{ V to }5.5\text{ V}$ ,  $V_{ref} = 3.3\text{ V to }AV_{CC}$  if A/D and D/A not used (pins used  
as I/O ports),  $V_{SS} = AV_{SS} = PLLV_{SS} = 0\text{ V}$ ,  $\phi = 2\text{ to }16\text{ MHz}$ ,  $T_a = -20^\circ\text{C to }+75^\circ\text{C}$   
(regular specifications),  $T_a = -40^\circ\text{C to }+85^\circ\text{C}$  (wide-range specifications)

Condition B:  $V_{CC} = PLLV_{CC} = 3.0\text{ V to }3.6\text{ V}$ ,  $PV_{CC} = 4.5\text{ V to }5.5\text{ V}$ ,  $AV_{CC} = 4.5\text{ V to }5.5\text{ V}$ ,  
 $V_{ref} = 4.5\text{ V to }AV_{CC}$ ,  $V_{SS} = AV_{SS} = PLLV_{SS} = 0\text{ V}$ ,  $\phi = 2\text{ to }25\text{ MHz}$ ,  $T_a = -20^\circ\text{C to }+75^\circ\text{C}$   
+75°C (regular specifications),  $T_a = -40^\circ\text{C to }+85^\circ\text{C}$  (wide-range specifications)

Item	Condition A			Condition B			Unit
	Min	Typ	Max	Min	Typ	Max	
Resolution	10	10	10	10	10	10	bits
Conversion time	16	—	—	10	—	—	$\mu\text{s}$
Analog input capacitance	—	—	20	—	—	20	pF
Permissible signal-source impedance	—	—	5	—	—	5	k $\Omega$
Nonlinearity error	—	—	$\pm 7.5$	—	—	$\pm 3.5$	LSB
Offset error	—	—	$\pm 7.5$	—	—	$\pm 3.5$	LSB
Full-scale error	—	—	$\pm 7.5$	—	—	$\pm 3.5$	LSB
Quantization	—	$\pm 0.5$	—	—	$\pm 0.5$	—	LSB
Absolute accuracy	—	—	$\pm 8.0$	—	—	$\pm 4.0$	LSB

## 25.5 D/A Conversion Characteristics

Table 25-12 shows the D/A conversion characteristics.

**Table 25-12 D/A Conversion Characteristics**

Condition A:  $V_{CC} = PLLV_{CC} = 3.0\text{ V to }3.6\text{ V}$ ,  $PV_{CC} = 3.0\text{ V to }5.5\text{ V}$ ,  
 $AV_{CC} = 3.6\text{ V to }5.5\text{ V}$ ,  $V_{ref} = 3.6\text{ V to }AV_{CC}$  if A/D and D/A used,  
 $AV_{CC} = 3.3\text{ V to }5.5\text{ V}$ ,  $V_{ref} = 3.3\text{ V to }AV_{CC}$  if A/D and D/A not used (pins used  
as I/O ports),  $V_{SS} = AV_{SS} = PLLV_{SS} = 0\text{ V}$ ,  $\phi = 2\text{ to }16\text{ MHz}$ ,  $T_a = -20^\circ\text{C to }+75^\circ\text{C}$   
(regular specifications),  $T_a = -40^\circ\text{C to }+85^\circ\text{C}$  (wide-range specifications)

Condition B:  $V_{CC} = PLLV_{CC} = 3.0\text{ V to }3.6\text{ V}$ ,  $PV_{CC} = 4.5\text{ V to }5.5\text{ V}$ ,  $AV_{CC} = 4.5\text{ V to }5.5\text{ V}$ ,  
 $V_{ref} = 4.5\text{ V to }AV_{CC}$ ,  $V_{SS} = AV_{SS} = PLLV_{SS} = 0\text{ V}$ ,  $\phi = 2\text{ to }25\text{ MHz}$ ,  $T_a = -20^\circ\text{C to }+75^\circ\text{C}$   
(regular specifications),  $T_a = -40^\circ\text{C to }+85^\circ\text{C}$  (wide-range specifications)

Item	Condition A			Condition B			Unit	Test Conditions
	Min	Typ	Max	Min	Typ	Max		
Resolution	8	8	8	8	8	8	bits	
Conversion time	—	—	10	—	—	10	$\mu\text{s}$	20-pF capacitive load
Absolute accuracy	—	$\pm 2.0$	$\pm 3.0$	—	$\pm 1.5$	$\pm 2.0$	LSB	2-M $\Omega$ resistive load
	—	—	$\pm 2.0$	—	—	$\pm 1.5$	LSB	4-M $\Omega$ resistive load

## 25.6 Flash Memory Characteristics

**Table 25-13 Flash Memory Characteristics**

Conditions:  $V_{CC} = PLLV_{CC} = 3.0\text{ V to }3.6\text{ V}$ ,  $PV_{CC} = 4.5\text{ V to }5.5\text{ V}$ ,  $AV_{CC} = 4.5\text{ V to }5.5\text{ V}$ ,  
 $V_{SS} = AV_{SS} = PLLV_{SS} = 0\text{ V}$ ,  $T_a = -20^\circ\text{C to }+75^\circ\text{C}$  (regular specifications),  $T_a = -40^\circ\text{C to }+85^\circ\text{C}$  (wide-range specifications)

Item	Symbol	Min	Typ	Max	Unit	
Programming time* <sup>1</sup> * <sup>2</sup> * <sup>4</sup>	$t_P$	—	10	200	ms/128 bytes	
Erase time* <sup>1</sup> * <sup>3</sup> * <sup>5</sup>	$t_E$	—	100	1000	ms/block	
Number of rewrites	$N_{WEC}$	—	50	100	Times	
Programming	Wait time after SWE1 bit setting* <sup>1</sup>	x0	1	—	—	$\mu\text{s}$
	Wait time after PSU1 bit setting* <sup>1</sup>	y	50	—	—	$\mu\text{s}$
	Wait time after P1 bit setting* <sup>1</sup> * <sup>4</sup>	z0	—	—	30	$\mu\text{s}$
		z1	—	—	10	$\mu\text{s}$
		z2	—	—	200	$\mu\text{s}$
	Wait time after P1 bit clearing* <sup>1</sup>	$\alpha$	5	—	—	$\mu\text{s}$
	Wait time after PSU1 bit clearing* <sup>1</sup>	$\beta$	5	—	—	$\mu\text{s}$
	Wait time after PV1 bit setting* <sup>1</sup>	$\gamma$	4	—	—	$\mu\text{s}$
	Wait time after H'FF dummy write* <sup>1</sup>	$\varepsilon$	2	—	—	$\mu\text{s}$
	Wait time after PV1 bit clearing* <sup>1</sup>	$\eta$	2	—	—	$\mu\text{s}$
	Maximum number of writes* <sup>1</sup> * <sup>4</sup>	N1	—	—	6	Times
		N2	—	—	994	Times
Common	Wait time after SWE1 bit clearing* <sup>1</sup>	x1	100	—	—	$\mu\text{s}$
Erasing	Wait time after SWE1 bit setting* <sup>1</sup>	x	1	—	—	$\mu\text{s}$
	Wait time after ESU1 bit setting* <sup>1</sup>	y	100	—	—	$\mu\text{s}$
	Wait time after E1 bit setting* <sup>1</sup> * <sup>5</sup>	z	—	—	10	ms
	Wait time after E1 bit clearing* <sup>1</sup>	$\alpha$	10	—	—	$\mu\text{s}$
	Wait time after ESU1 bit clearing* <sup>1</sup>	$\beta$	10	—	—	$\mu\text{s}$
	Wait time after EV1 bit setting* <sup>1</sup>	$\gamma$	6	—	—	$\mu\text{s}$
	Wait time after H'FF dummy write* <sup>1</sup>	$\varepsilon$	2	—	—	$\mu\text{s}$
	Wait time after EV1 bit clearing* <sup>1</sup>	$\eta$	4	—	—	$\mu\text{s}$
Maximum number of erases* <sup>1</sup> * <sup>5</sup>	N	—	—	100	Times	

Notes: \*1 Follow the program/erase algorithms when making the time settings.

\*2 Programming time per 128 bytes. (Indicates the total time during which the P1 bit is set in flash memory control register 1 (FLMCR1). Does not include the program-verify time.)

- \*3 Time to erase one block. (Indicates the time during which the E1 bit is set in FLMCR1. Does not include the erase-verify time.)
- \*4 Maximum programming time  
( $t_P(\text{max}) = \text{Wait time after P1 bit setting (z)} \times \text{maximum number of writes (N)}$ )  
( $z_0 + z_1) \times 6 + z_2 \times 994$ )
- \*5 Maximum erase time  
( $t_E(\text{max}) = \text{Wait time after E1 bit setting (z)} \times \text{maximum number of erases (N)}$ )

## 25.7 Usage Note

Although both the F-ZTAT and mask ROM versions fully meet the electrical specifications listed in this manual, due to differences in the fabrication process, the on-chip ROM, and the layout patterns, there will be differences in the actual values of the electrical characteristics, the operating margins, the noise margins, and other aspects.

Therefore, if a system is evaluated using the F-ZTAT version, a similar evaluation should also be performed using the mask ROM version.





## Section 26 Electrical Characteristics (H8S/2633R)

### 26.1 Absolute Maximum Ratings

Table 26-1 lists the absolute maximum ratings. Unless specified otherwise,  $PV_{CC}$  refers to both  $PV_{CC1}$  and  $PV_{CC2}$ .

**Table 26-1 Absolute Maximum Ratings**

Item	Symbol	Value	Unit
Power supply voltage	$PV_{CC1,2}$	-0.3 to +7.0	V
Input voltage (XTAL, EXTAL)	$V_{in}$	-0.3 to $PV_{CC} + 0.3$	V
Input voltage (ports 4 and 9)	$V_{in}$	-0.3 to $AV_{CC} + 0.3$	V
Input voltage (except XTAL, EXTAL, ports 4 and 9)	$V_{in}$	-0.3 to $PV_{CC} + 0.3$	V
Reference voltage	$V_{ref}$	-0.3 to $AV_{CC} + 0.3$	V
Analog power supply voltage	$AV_{CC}$	-0.3 to +7.0	V
Analog input voltage	$V_{AN}$	-0.3 to $AV_{CC} + 0.3$	V
Operating temperature	$T_{opr}$	Regular specifications: -20 to +75	°C
		Wide-range specifications: -40 to +85	°C
Storage temperature	$T_{stg}$	-55 to +125	°C

Caution: Permanent damage to the chip may result if absolute maximum rating are exceeded.

## 26.2 DC Characteristics

Table 26-2 lists the DC characteristics. Table 26-3 lists the permissible output currents.

**Table 26-2 DC Characteristics**

Conditions:  $PV_{CC} = 4.5\text{ V to }5.5\text{ V}$ ,  $AV_{CC} = 4.5\text{ V to }5.5\text{ V}$ ,  $V_{ref} = 4.5\text{ V to }AV_{CC}$ ,  
 $V_{SS} = AV_{SS} = PLLV_{SS} = 0\text{ V}$ ,  $T_a = -20^\circ\text{C to }+75^\circ\text{C}$  (regular specifications),  
 $T_a = -40^\circ\text{C to }+85^\circ\text{C}$  (wide-range specifications)\*<sup>1</sup>

Item	Symbol	Min	Typ	Max	Unit	Test Conditions
Schmitt trigger input voltage	$\overline{IRQ7}$ to $\overline{IRQ0}$	$V_T^-$	1.0	—	—	V
		$V_T^+$	—	—	$PV_{CC} \times 0.7$	V
		$V_T^+ - V_T^-$	0.4	—	—	V
Input high voltage	$\overline{RES}$ , $\overline{STBY}$ , NMI, $FWE^{*5}$ , MD2 to MD0	$V_{IH}$	$PV_{CC} - 0.7$	—	$PV_{CC} + 0.3$	V
	Ports 1, 3, 7, A to G		2.2	—	$PV_{CC} + 0.3$	V
	Ports 4 and 9		$AV_{CC} \times 0.7$	—	$AV_{CC} + 0.3$	V
	EXTAL		$PV_{CC} \times 0.8$	—	$PV_{CC} + 0.3$	V
Input low voltage	$\overline{RES}$ , $\overline{STBY}$ , NMI, $FWE^{*5}$ , MD2 to MD0	$V_{IL}$	-0.3	—	0.5	V
	Ports 1, 3, 4, 7, 9, A to G		-0.3	—	0.8	V
	EXTAL		-0.3	—	$PV_{CC} \times 0.2$	V
Output high voltage	All output pins except P34 and P35	$V_{OH}$	$PV_{CC} - 0.5$	—	—	V $I_{OH} = -200\ \mu\text{A}$
	P34, P35		$PV_{CC} - 2.5$	—	—	$I_{OH} = -100\ \mu\text{A}$
	All output pins except P34 and P35		3.5	—	—	$I_{OH} = -1\ \text{mA}$
Output low voltage	All output pins	$V_{OL}$	—	—	0.4	V $I_{OL} = 1.6\ \text{mA}$
Input leakage current	$\overline{RES}$ , $FWE^{*5}$	$ I_{in} $	—	—	1.0	$\mu\text{A}$ $V_{in} = 0.5\ \text{V to }PV_{CC} - 0.5\ \text{V}$
	$\overline{STBY}$ , NMI, MD2 to MD0		—	—	1.0	$\mu\text{A}$
	Ports 4, 9		—	—	1.0	$\mu\text{A}$ $V_{in} = 0.5\ \text{V to }AV_{CC} - 0.5\ \text{V}$

Item		Symbol	Min	Typ	Max	Unit	Test Conditions
Three-state leakage current (off state)	Ports 1, 3, 7, A to G	$ I_{TSL} $	—	—	1.0	$\mu\text{A}$	$V_{in} = 0.5 \text{ V}$ to $PV_{CC} - 0.5 \text{ V}$
MOS input pull-up current	Ports A to E	$-I_P$	50	—	300	$\mu\text{A}$	$V_{in} = 0 \text{ V}$
Input capacitance	$\overline{\text{RES}}$	$C_{in}$	—	—	30	$\text{pF}$	$V_{in} = 0 \text{ V}$ $f = 1 \text{ MHz}$ $T_a = 25^\circ\text{C}$
	NMI		—	—	30	$\text{pF}$	
	All input pins except $\overline{\text{RES}}$ and NMI		—	—	15	$\text{pF}$	
Current dissipation* <sup>2</sup>	Normal operation	$I_{CC}^{*4}$	—	70	84	$\text{mA}$	$f = 28 \text{ MHz}$
	Sleep mode		—	55	77	$\text{mA}$	$f = 28 \text{ MHz}$
	All modules stopped		—	40	—	$\text{mA}$	$f = 28 \text{ MHz}$ (reference values)
	Medium-speed mode ( $\phi/32$ )		—	54	—	$\text{mA}$	$f = 28 \text{ MHz}$ (reference values)
	Subactive mode		—	120	200	$\mu\text{A}$	Using 32.768 kHz crystal resonator
	Subsleep mode		—	70	150	$\mu\text{A}$	Using 32.768 kHz crystal resonator
	Watch mode		—	20	50	$\mu\text{A}$	Using 32.768 kHz crystal resonator
	Standby mode		—	—	0.1	5.0	$\mu\text{A}$
—		—	—	—	20	$50^\circ\text{C} < T_a$	

Item		Symbol	Min	Typ	Max	Unit	Test Conditions
Analog power supply current	During A/D and D/A conversion	$I_{CC}$	—	0.6	2.0	mA	$AV_{CC} = 5.0\text{ V}$
	Idle		—	0.1 $T_a = 25^\circ\text{C}$	5.0	$\mu\text{A}$	
Reference power supply current	During A/D and D/A conversion	$I_{CC}$	—	4.0	5.0	mA	$V_{ref} = 5.0\text{ V}$
	Idle		—	0.1 $T_a = 25^\circ\text{C}$	5.0	$\mu\text{A}$	
RAM standby voltage <sup>*3</sup>		$V_{RAM}$	2.0	—	—	V	

Notes: \*1 If the A/D and D/A converters are not used, do not leave the  $AV_{CC}$ ,  $V_{ref}$ , and  $AV_{SS}$  pins open. Apply a voltage between 3.3 V and 5.5 V to the  $AV_{CC}$  and  $V_{ref}$  pins by connecting them to  $PV_{CC}$ , for instance. Set  $V_{ref} \leq AV_{CC}$ .

\*2 Current dissipation values are for  $V_{IH} = PV_{CC}$  (EXTAL),  $AV_{CC}$  (ports 4 and 9), or  $PV_{CC}$  (other), and  $V_{IL} = 0\text{ V}$ , with all output pins unloaded and the on-chip MOS pull-up transistors in the off state.

\*3 The values are for  $V_{RAM} \leq PV_{CC} < 3.0\text{ V}$ ,  $V_{IH\ min} = PV_{CC} - 0.1\text{ V}$ , and  $V_{IL\ max} = 0.1\text{ V}$ .

\*4  $I_{CC}$  depends on  $PV_{CC}$  and  $f$  as follows:

$$I_{CC\ max} = 15\text{ (mA)} + 0.45\text{ (mA/(MHz} \times \text{V))} \times PV_{CC} \times f\text{ (normal operation)}$$

$$I_{CC\ max} = 15\text{ (mA)} + 0.4\text{ (mA/(MHz} \times \text{V))} \times PV_{CC} \times f\text{ (sleep mode)}$$

\*5 The FWE pin is used only in the flash memory version.

**Table 26-3 Permissible Output Currents**

Conditions:  $PV_{CC} = 4.5\text{ V to }5.5\text{ V}$ ,  $AV_{CC} = 4.5\text{ V to }5.5\text{ V}$ ,  $V_{ref} = 4.5\text{ V to }AV_{CC}$ ,  
 $V_{SS} = AV_{SS} = PLLV_{SS} = 0\text{ V}$ ,  $T_a = -20^\circ\text{C to }+75^\circ\text{C}$  (regular specifications),  
 $T_a = -40^\circ\text{C to }+85^\circ\text{C}$  (wide-range specifications)

Item			Symbol	Min	Typ	Max	Unit
Permissible output low current (per pin)	All output pins	$PV_{CC} = 4.5\text{ V to }5.5\text{ V}$	$I_{OL}$	—	—	10	mA
Permissible output low current (total)	Total of all output pins	$PV_{CC} = 4.5\text{ V to }5.5\text{ V}$	$\Sigma I_{OL}$	—	—	120	mA
Permissible output high current (per pin)	All output pins	$PV_{CC} = 4.5\text{ V to }5.5\text{ V}$	$-I_{OH}$	—	—	2.0	mA
Permissible output high current (total)	Total of all output pins	$PV_{CC} = 4.5\text{ V to }5.5\text{ V}$	$\Sigma -I_{OH}$	—	—	40	mA

Note: To protect chip reliability, do not exceed the output current values in table 26-3.

**Table 26-4 Bus Drive Characteristics**

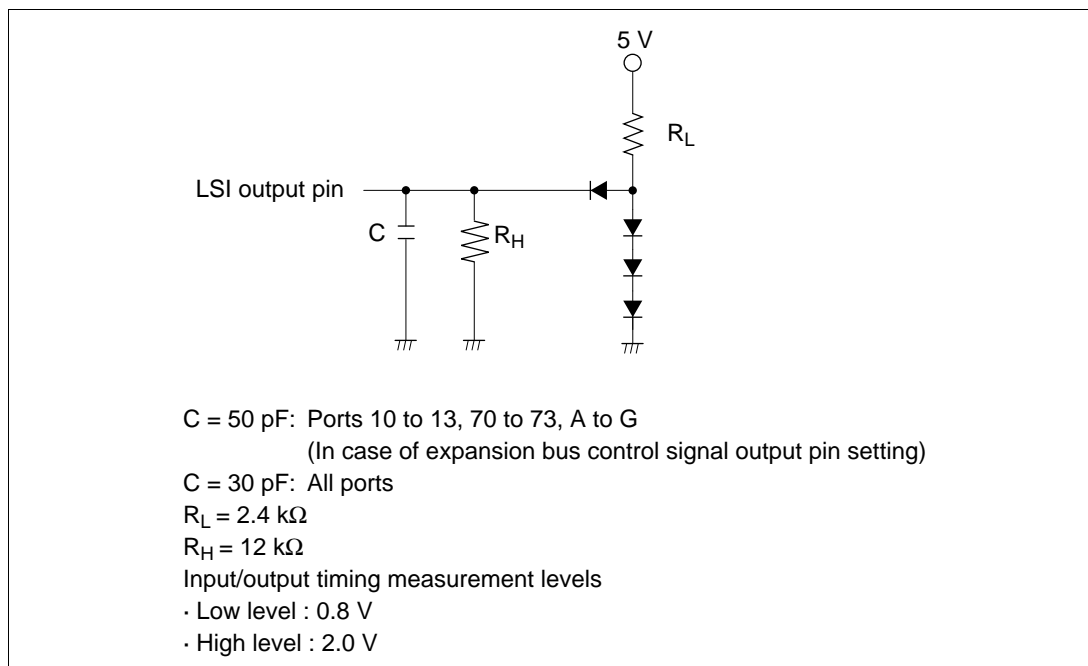
Condition :  $PV_{CC} = 4.5\text{ V to }5.5\text{ V}$ ,  $AV_{CC} = 4.5\text{ V to }5.5\text{ V}$ ,  $V_{ref} = 4.5\text{ V to }AV_{CC}$ ,  
 $V_{SS} = AV_{SS} = PLLV_{SS} = 0\text{ V}$ ,  $T_a = -20^\circ\text{C to }+75^\circ\text{C}$  (regular specifications),  
 $T_a = -40^\circ\text{C to }+85^\circ\text{C}$  (wide-range specifications)

Applicable Pins: SCL1-0, SDA1-0

Item	Symbol	Min	Typ	Max	Unit	Test Conditions
Schmitt trigger input voltage	$V_{T-}$	$PV_{CC} \times 0.3$	—	—	V	
	$V_{T+}$	—	—	$PV_{CC} \times 0.7$		
	$V_{T+} - V_{T-}$	0.4	—	—		$PV_{CC} = 4.5\text{ V to }5.5\text{ V}$
Input high voltage	$V_{IH}$	$PV_{CC} \times 0.7$	—	$PV_{CC} + 0.5$	V	
Input low voltage	$V_{IL}$	- 0.5	—	$PV_{CC} \times 0.3$	V	
Output low voltage	$V_{OL}$	—	—	0.7	V	$I_{OL} = 8\text{ mA}$ , $PV_{CC} = 4.5\text{ V to }5.5\text{ V}$
		—	—	0.4		$I_{OL} = 3\text{ mA}$ , $PV_{CC} = 4.5\text{ V to }5.5\text{ V}$
Input capacitance	$C_{in}$	—	—	20	pF	$V_{in} = 0\text{ V}$ , $f = 1\text{ MHz}$ , $T_a = 25^\circ\text{C}$
Three-state leakage current (off state)	$ I_{TSL} $	—	—	1.0	$\mu\text{A}$	$V_{in} = 0.5\text{ V to }PV_{CC} - 0.5\text{ V}$
SCL, SDA, output fall time	$t_{Of}$	$20 + 0.1 C_b$	—	250	ns	

## 26.3 AC Characteristics

Figure 26-1 show, the test conditions for the AC characteristics.



**Figure 26-1 Output Load Circuit**

### 26.3.1 Clock Timing

Table 26-5 lists the clock timing

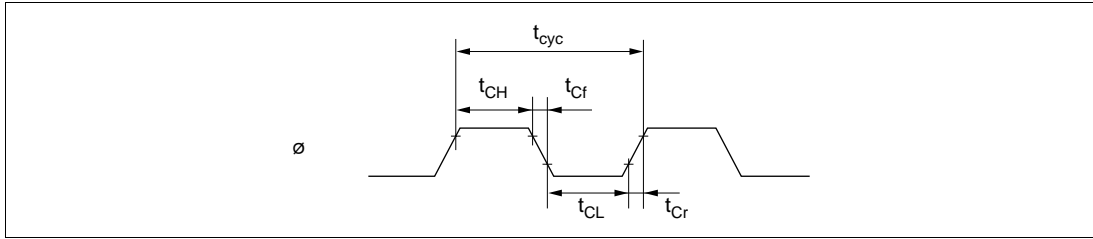
**Table 26-5 Clock Timing**

Condition:  $PV_{CC} = 4.5\text{ V to }5.5\text{ V}$ ,  $AV_{CC} = 4.5\text{ V to }5.5\text{ V}$ ,  $V_{ref} = 4.5\text{ V to }AV_{CC}$ ,  
 $V_{SS} = AV_{SS} = PLLV_{SS} = 0\text{ V}$ ,  $\phi = 32.768\text{ kHz, }2\text{ to }28\text{ MHz}^*$ ,  
 $T_a = -20^\circ\text{C to }+75^\circ\text{C}$  (regular specifications),  $T_a = -40^\circ\text{C to }+85^\circ\text{C}$  (wide-range specifications)

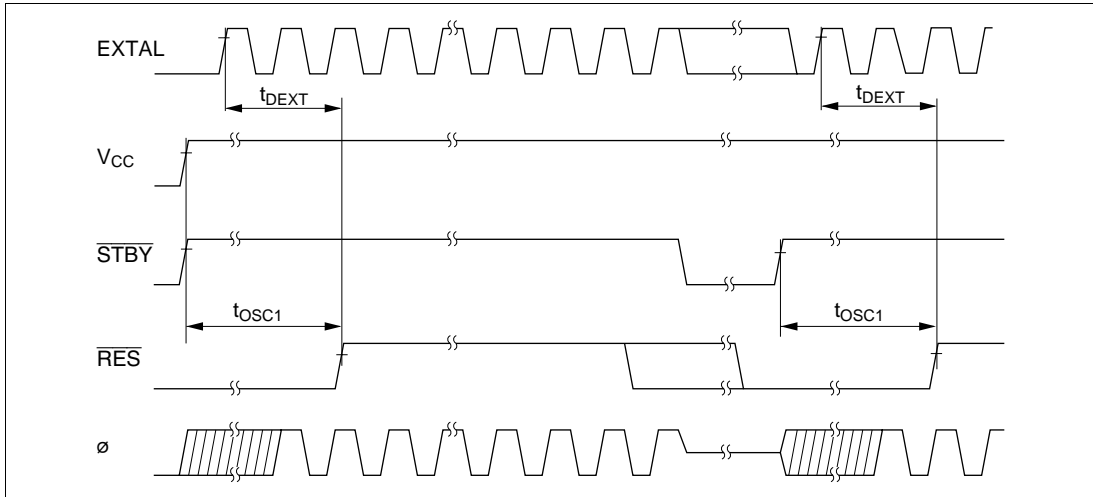
Item	Symbol	28MHz		Unit	Test Conditions
		Min	Max		
Clock cycle time	$t_{cyc}$	35.7	500	ns	Figure 26-2
Clock high pulse width	$t_{CH}$	10	—	ns	
Clock low pulse width	$t_{CL}$	10	—	ns	
Clock rise time	$t_{Cr}$	—	5	ns	
Clock fall time	$t_{Cf}$	—	5	ns	
Clock oscillator settling time at reset (crystal)	$t_{OSC1}$	10	—	ms	Figure 26-3
Clock oscillator settling time in software standby (crystal)	$t_{OSC2}$	5	—	ms	Figure 24-3
External clock output stabilization delay time	$t_{DEXT}$	2	—	ms	Figure 26-3
32 kHz clock oscillation settling time	$t_{OSC3}$	—	2	s	
Sub clock oscillator frequency	$f_{SUB}$	32.768	32.768	kHz	
Sub clock ( $\phi_{SUB}$ ) cycle time	$t_{SUB}$	30.5	30.5	$\mu\text{s}$	

Note: \* The input clock frequency should be set to 25 MHz or less. If  $\phi = 25\text{ MHz to }28\text{ MHz}$ , use the PLL to multiply the frequency ( $\times 2$  or  $\times 4$ ).





**Figure 26-2 System Clock Timing**



**Figure 26-3 Oscillator Settling Timing**

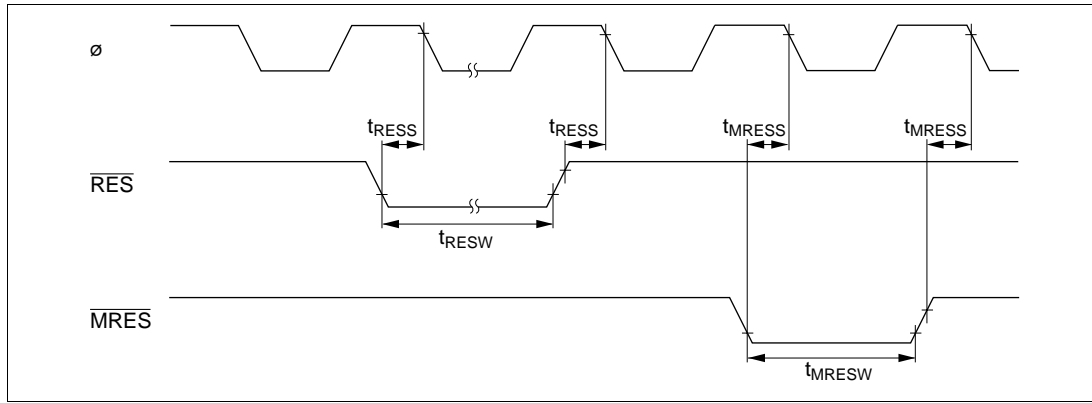
### 26.3.2 Control Signal Timing

Table 26-6 lists the control signal timing.

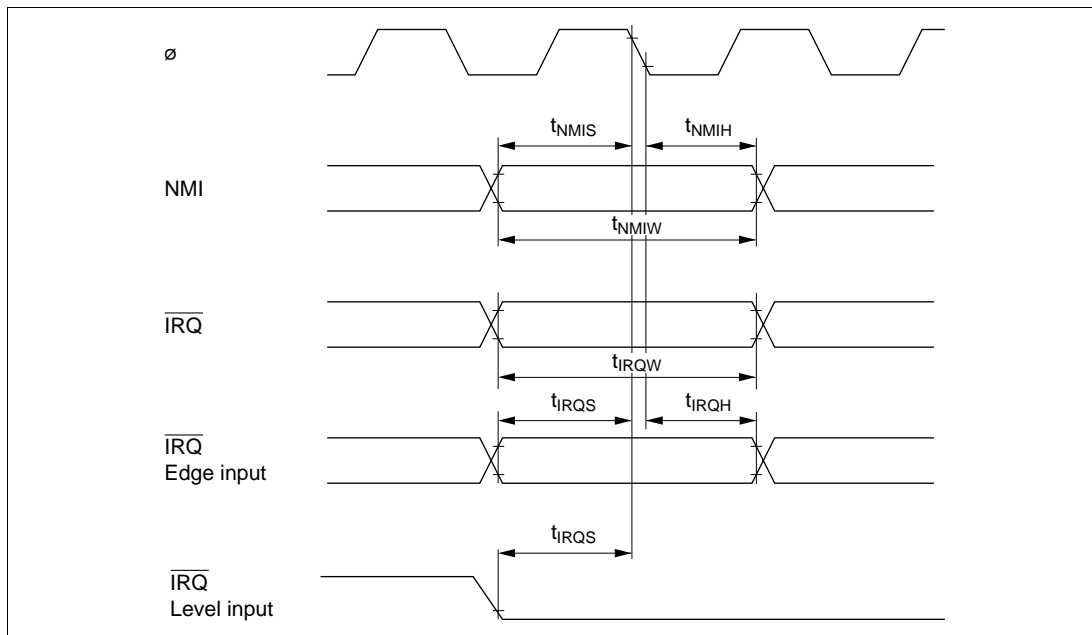
**Table 26-6 Control Signal Timing**

Condition:  $PV_{CC} = 4.5\text{ V to }5.5\text{ V}$ ,  $AV_{CC} = 4.5\text{ V to }5.5\text{ V}$ ,  $V_{ref} = 4.5\text{ V to }AV_{CC}$ ,  
 $V_{SS} = AV_{SS} = PLLV_{SS} = 0\text{ V}$ ,  $\phi = 32.768\text{ kHz}$ , 2 to 28 MHz,  
 $T_a = -20^\circ\text{C to }+75^\circ\text{C}$  (regular specifications),  $T_a = -40^\circ\text{C to }+85^\circ\text{C}$  (wide-range specifications)

Item	Symbol	Min	Max	Unit	Test Conditions
$\overline{\text{RES}}$ setup time	$t_{\text{RESS}}$	200	—	ns	Figure 26-4
$\overline{\text{RES}}$ pulse width	$t_{\text{RESW}}$	20	—	$t_{\text{cyc}}$	
$\overline{\text{MRES}}$ setup time	$t_{\text{MRESS}}$	250	—	ns	
$\overline{\text{MRES}}$ pulse width	$t_{\text{MRESW}}$	20	—	$t_{\text{cyc}}$	
NMI setup time	$t_{\text{NMIS}}$	150	—	ns	Figure 26-5
NMI hold time	$t_{\text{NMIH}}$	10	—		
NMI pulse width (exiting software standby mode)	$t_{\text{NMIW}}$	200	—	ns	
$\overline{\text{IRQ}}$ setup time	$t_{\text{IRQS}}$	150	—	ns	
$\overline{\text{IRQ}}$ hold time	$t_{\text{IRQH}}$	10	—	ns	
$\overline{\text{IRQ}}$ pulse width (exiting software standby mode)	$t_{\text{IRQW}}$	200	—	ns	



**Figure 26-4 Reset Input Timing**



**Figure 26-5 Interrupt Input Timing**

### 26.3.3 Bus Timing

Table 26-7 lists the bus timing.

**Table 26-7 Bus Timing**

Condition:  $PV_{CC} = 4.5\text{ V to }5.5\text{ V}$ ,  $AV_{CC} = 4.5\text{ V to }5.5\text{ V}$ ,  $V_{ref} = 4.5\text{ V to }AV_{CC}$ ,  
 $V_{SS} = AV_{SS} = PLLV_{SS} = 0\text{ V}$ ,  $\phi = 2\text{ to }28\text{ MHz}$ ,  $T_a = -20^\circ\text{C to }+75^\circ\text{C}$  (regular specifications),  $T_a = -40^\circ\text{C to }+85^\circ\text{C}$  (wide-range specifications)

Item	Symbol	Min	Max	Unit	Test Conditions
Address delay time	$t_{AD}$	—	20	ns	Figure 26-6 to
Address setup time	$t_{AS}$	$0.5 \times t_{cyc} - 13$	—	ns	figure 26-11
Address hold time	$t_{AH}$	$0.5 \times t_{cyc} - 8$	—	ns	
$\overline{CS}$ delay time 1	$t_{CSD1}$	—	15	ns	
$\overline{CS}$ delay time 2	$t_{CSD2}$	—	15	ns	
$\overline{AS}$ delay time	$t_{ASD}$	—	15	ns	
$\overline{RD}$ delay time 1	$t_{RSD1}$	—	15	ns	
$\overline{RD}$ delay time 2	$t_{RSD2}$	—	15	ns	
Read data setup time	$t_{RDS}$	15	—	ns	
Read data hold time	$t_{RDH}$	0	—	ns	
Read data access time 1	$t_{ACC1}$	—	$1.0 \times t_{cyc} - 15$	ns	
Read data access time 2	$t_{ACC2}$	—	$1.5 \times t_{cyc} - 15$	ns	
Read data access time 3	$t_{ACC3}$	—	$2.0 \times t_{cyc} - 15$	ns	
Read data access time 4	$t_{ACC4}$	—	$2.5 \times t_{cyc} - 15$	ns	
Read data access time 5	$t_{ACC5}$	—	$3.0 \times t_{cyc} - 15$	ns	
$\overline{WR}$ delay time 1	$t_{WRD1}$	—	15	ns	
$\overline{WR}$ delay time 2	$t_{WRD2}$	—	15	ns	
$\overline{WR}$ pulse width 1	$t_{WSW1}$	$1.0 \times t_{cyc} - 13$	—	ns	
$\overline{WR}$ pulse width 2	$t_{WSW2}$	$1.5 \times t_{cyc} - 13$	—	ns	
Write data delay time	$t_{WDD}$	—	22	ns	
Write data setup time	$t_{WDS}$	$0.5 \times t_{cyc} - 13$	—	ns	
Write data hold time	$t_{WDH}$	$0.5 \times t_{cyc} - 8$	—	ns	
$\overline{WR}$ setup time	$t_{WCS}$	$0.5 \times t_{cyc} - 10$	—	ns	
$\overline{WR}$ hold time	$t_{WCH}$	$0.5 \times t_{cyc} - 10$	—	ns	

Item	Symbol	Min	Max	Unit	Conditions
$\overline{\text{RAS}}$ precharge time	$t_{\text{PCH}}$	$1.5 \times t_{\text{cyc}} - 13$	—	ns	Figure 26-11 to figure 26-13
$\overline{\text{CAS}}$ precharge time 1	$t_{\text{CP1}}$	$1.0 \times t_{\text{cyc}} - 8$	—	ns	
$\overline{\text{CAS}}$ precharge time 2	$t_{\text{CP2}}$	$0.5 \times t_{\text{cyc}} - 8$	—	ns	
$\overline{\text{CAS}}$ delay time 1	$t_{\text{CASD1}}$	—	18	ns	
$\overline{\text{CAS}}$ delay time 2	$t_{\text{CASD2}}$	—	18	ns	
$\overline{\text{OE}}$ delay time 1	$t_{\text{OED1}}$	—	15	ns	
$\overline{\text{OE}}$ delay time 2	$t_{\text{OED2}}$	—	15	ns	
$\overline{\text{CAS}}$ setup time	$t_{\text{CSR}}$	$0.5 \times t_{\text{cyc}} - 8$	—	ns	
$\overline{\text{WAIT}}$ setup time	$t_{\text{WTS}}$	25	—	ns	Figure 26-8
$\overline{\text{WAIT}}$ hold time	$t_{\text{WTH}}$	5	—	ns	
$\overline{\text{BREQ}}$ setup time	$t_{\text{BRQS}}$	30	—	ns	Figure 26-14
$\overline{\text{BACK}}$ delay time	$t_{\text{BACD}}$	—	15	ns	
Bus-floating time	$t_{\text{BZD}}$	—	40	ns	
$\overline{\text{BREQO}}$ delay time	$t_{\text{BRQOD}}$	—	25	ns	Figure 26-15

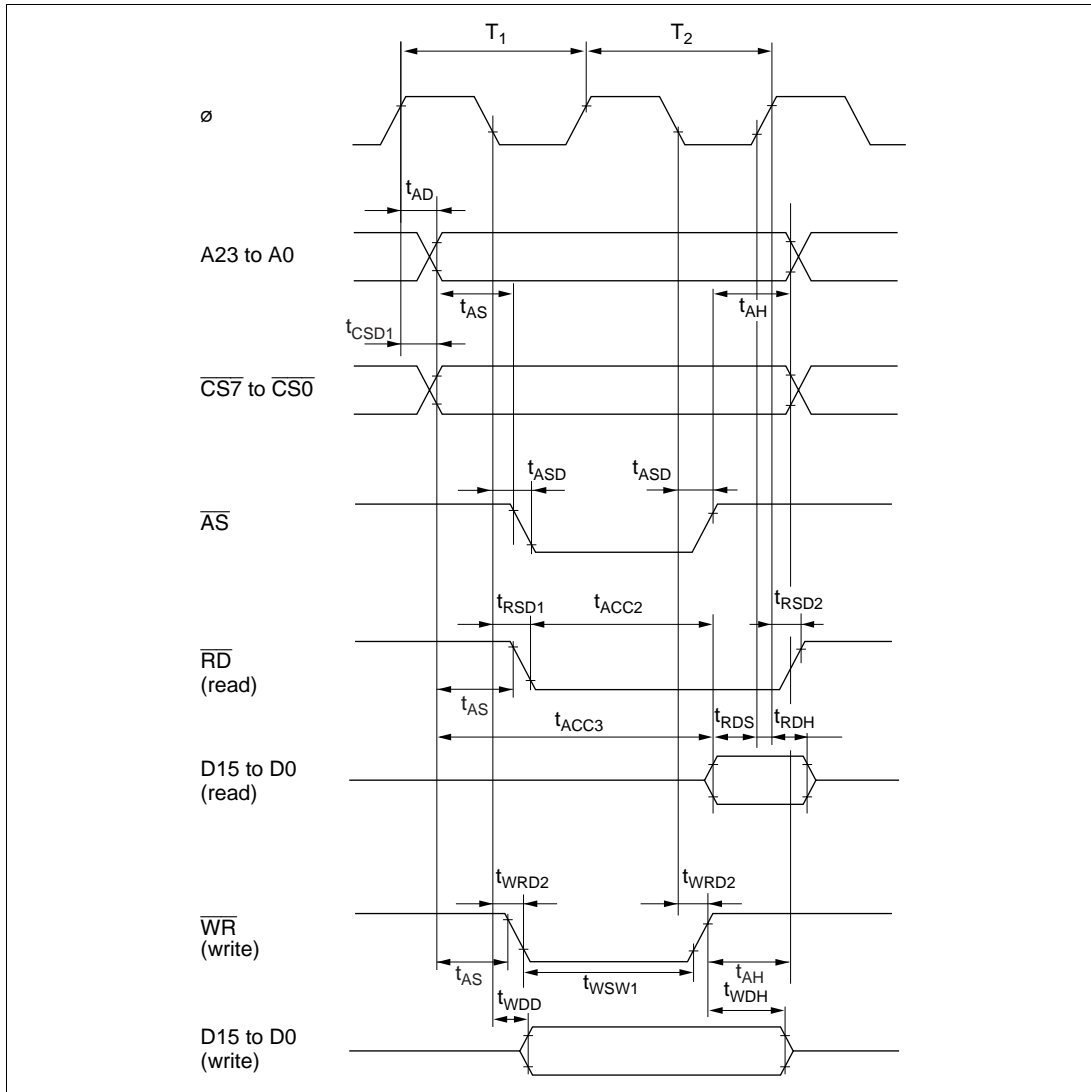


Figure 26-6 Basic Bus Timing (Two-State Access)

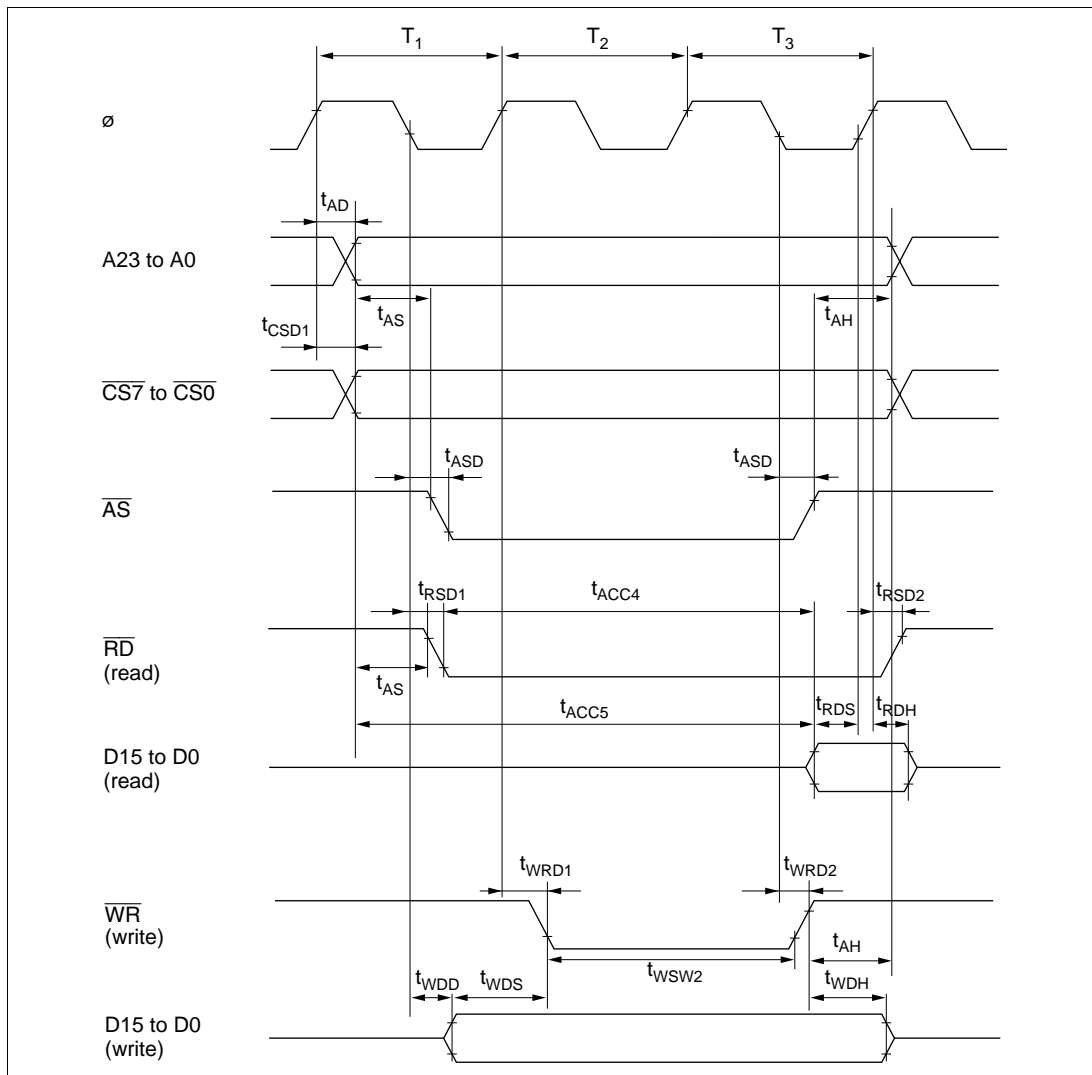


Figure 26-7 Basic Bus Timing (Three-State Access)

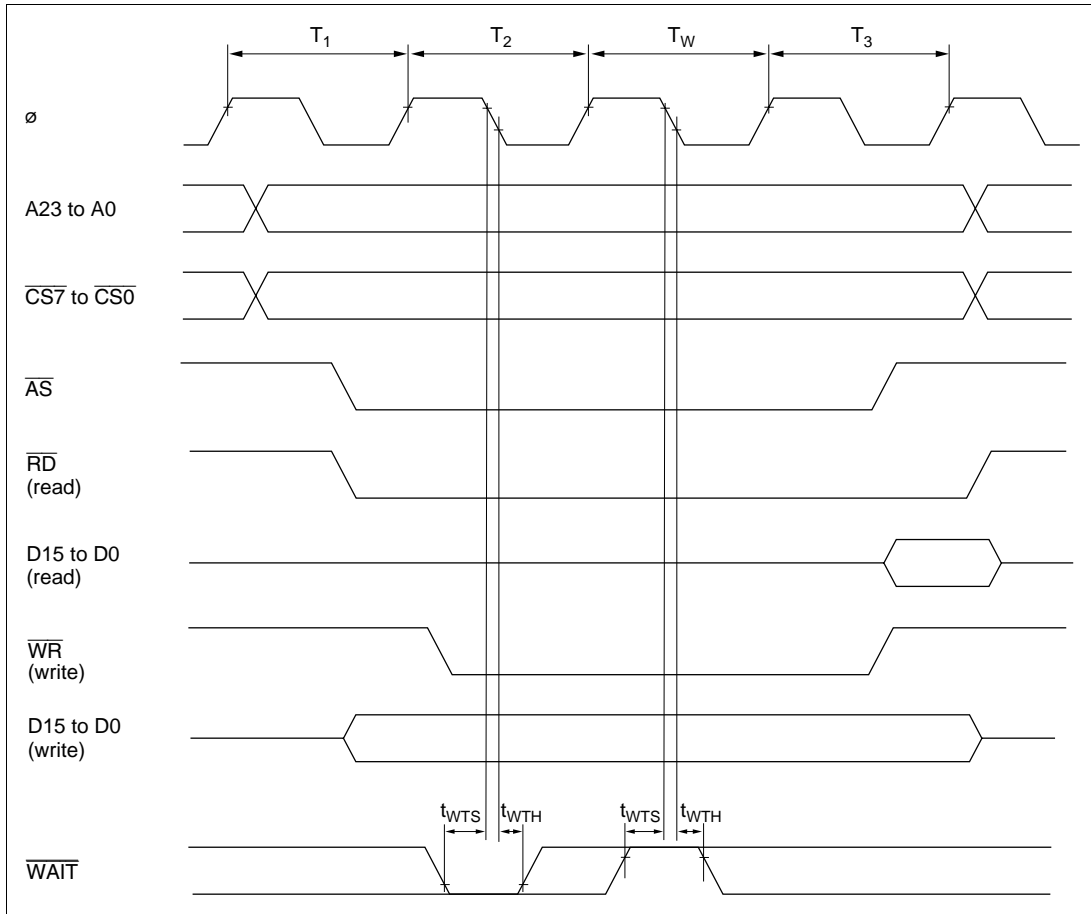
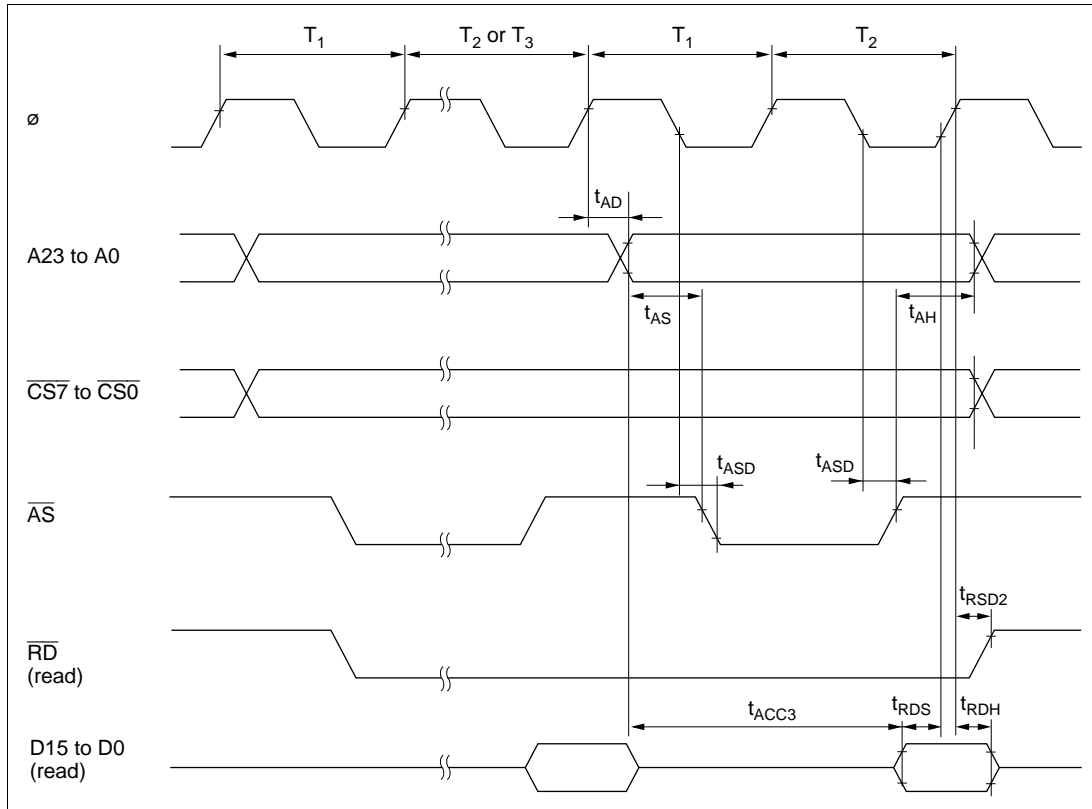
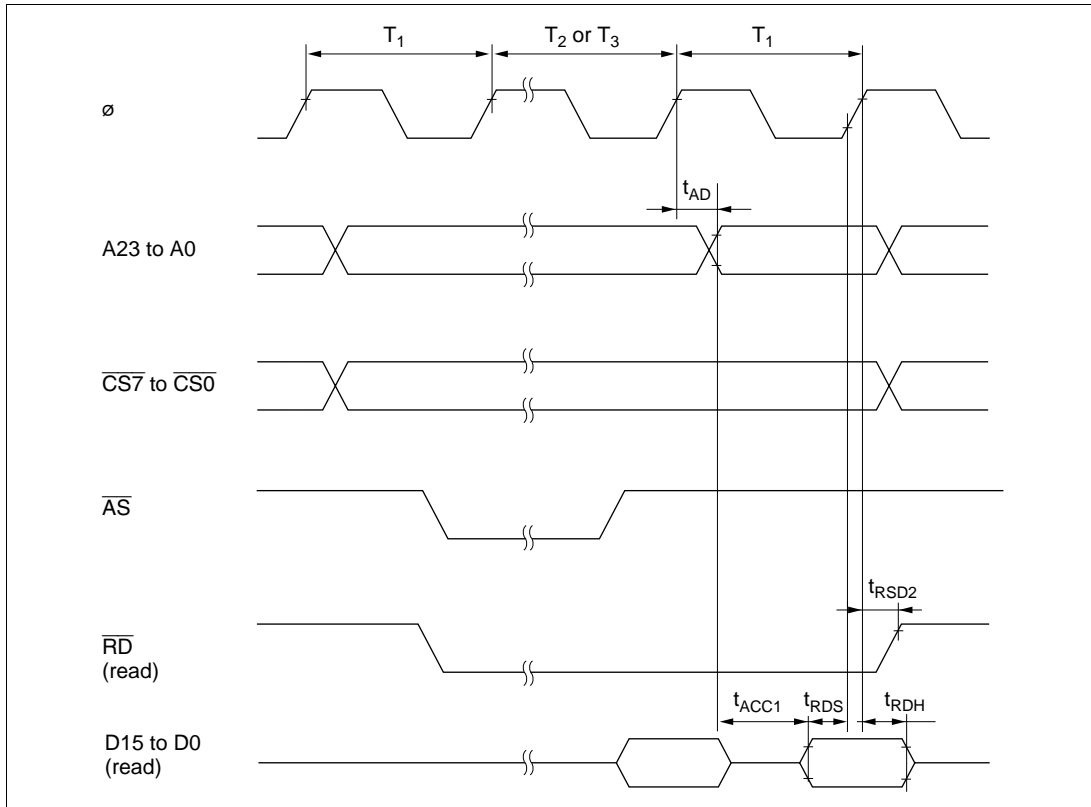


Figure 26-8 Basic Bus Timing (Three-State Access with One Wait State)





**Figure 26-9 Burst ROM Access Timing (Two-State Access)**



**Figure 26-10 Burst ROM Access Timing (One-State Access)**

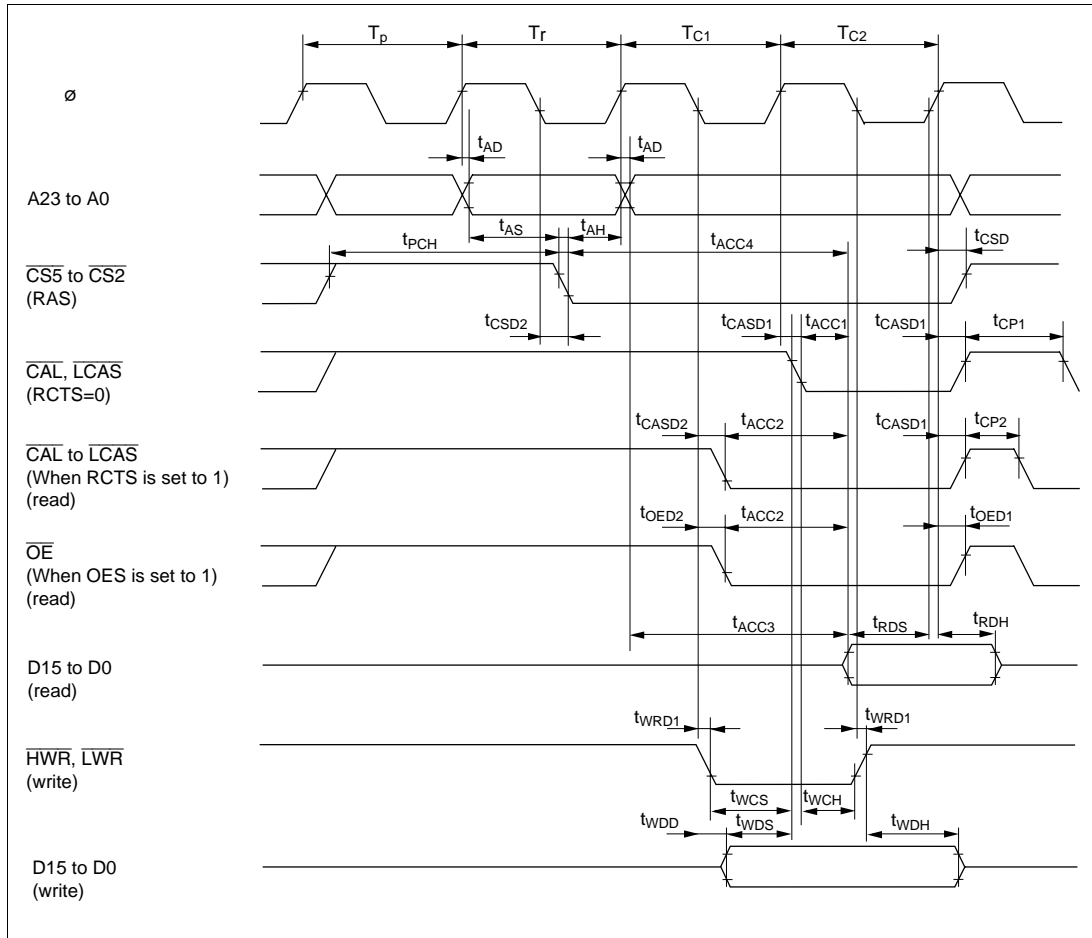


Figure 26-11 DRAM Access Timing

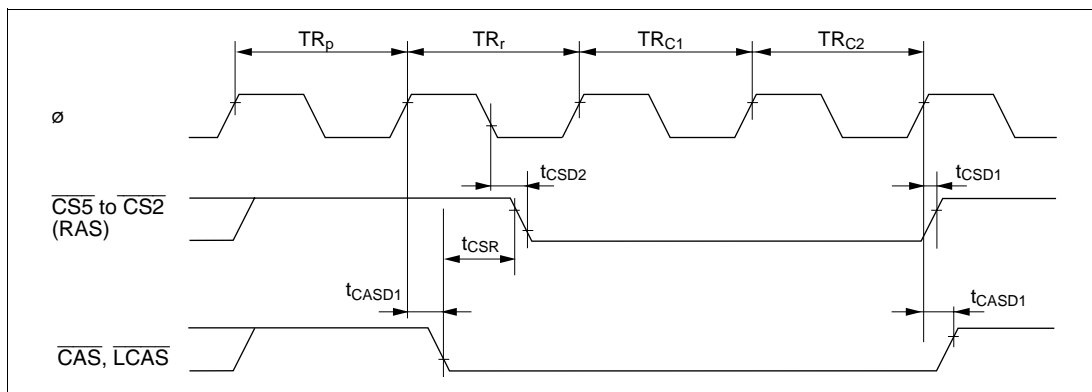


Figure 26-12 DRAM CBR Refresh Timing

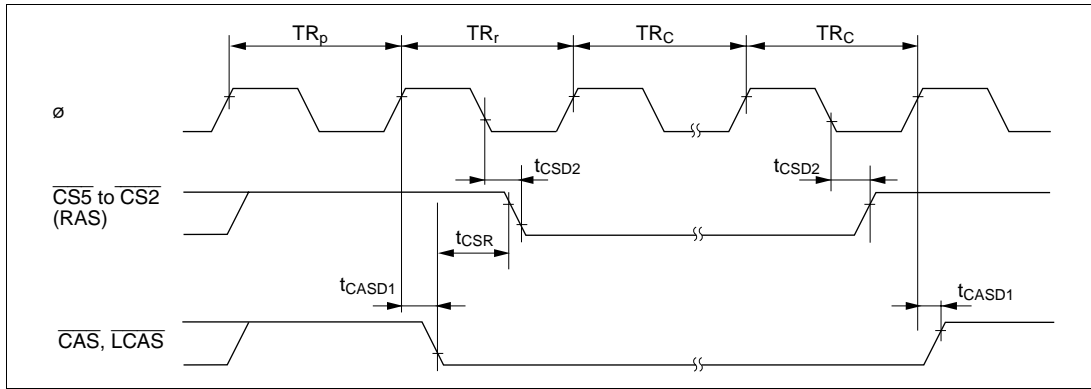


Figure 26-13 DRAM Self-Refresh Timing

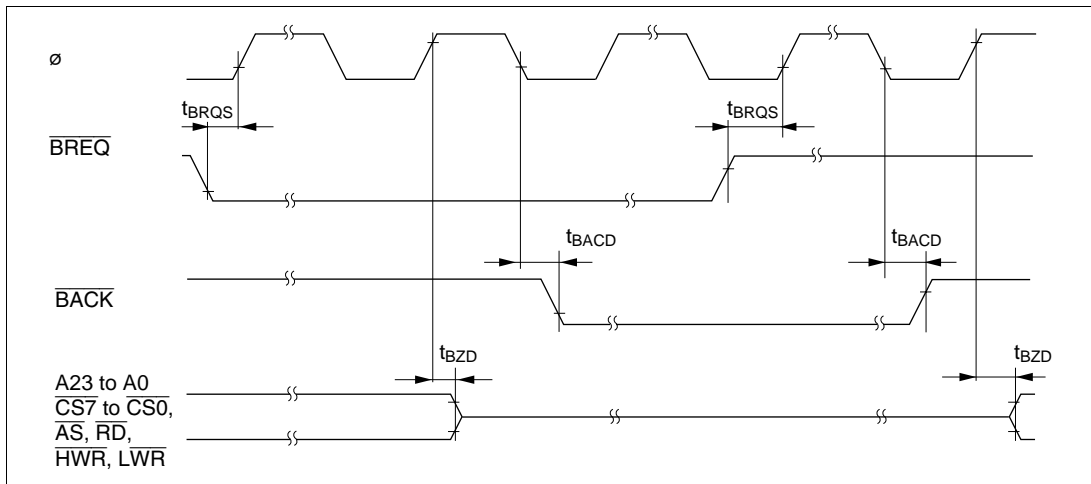


Figure 26-14 External Bus Release Timing

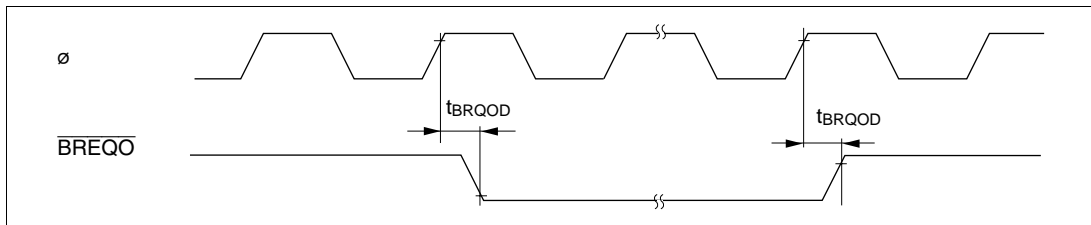


Figure 26-15 External Bus Request Output Timing

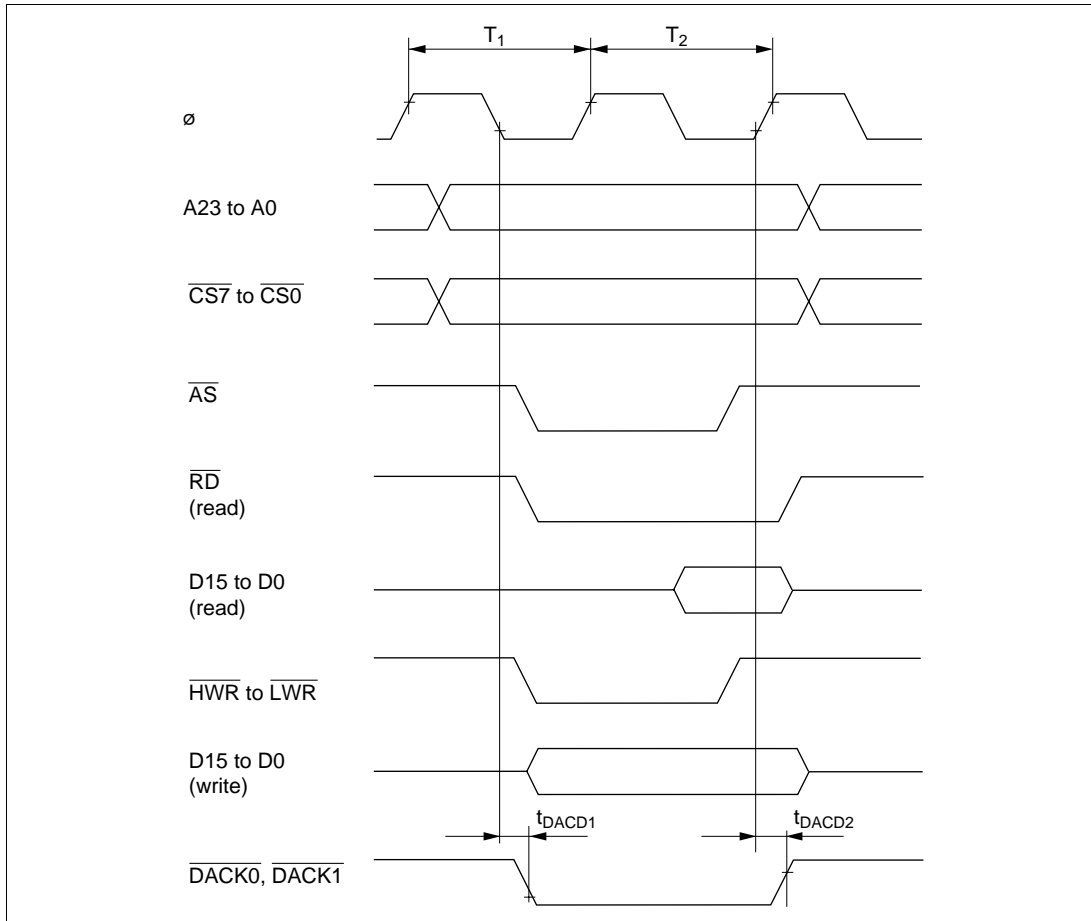
### 26.3.4 DMAC Timing

Table 26-8 shows the DMAC timing.

**Table 26-8 DMAC Timing**

Condition:  $PV_{CC} = 4.5\text{ V to }5.5\text{ V}$ ,  $AV_{CC} = 4.5\text{ V to }5.5\text{ V}$ ,  $V_{ref} = 4.5\text{ V to }AV_{CC}$ ,  
 $V_{SS} = AV_{SS} = PLLV_{SS} = 0\text{ V}$ ,  $\phi = 2\text{ to }28\text{ MHz}$ ,  $T_a = -20^\circ\text{C to }+75^\circ\text{C}$  (regular  
specifications),  $T_a = -40^\circ\text{C to }+85^\circ\text{C}$  (wide-range specifications)

Item	Symbol	Min	Max	Unit	Test Conditions
$\overline{\text{DREQ}}$ setup time	$t_{\text{DRQS}}$	25	—	ns	Figure 26-19
$\overline{\text{DREQ}}$ hold time	$t_{\text{DRQH}}$	10	—		
$\overline{\text{TEND}}$ delay time	$t_{\text{TED}}$	—	18		Figure 26-18
$\overline{\text{DACK}}$ delay time1	$t_{\text{DACD1}}$	—	18	ns	Figure 26-16,
$\overline{\text{DACK}}$ delay time2	$t_{\text{DACD2}}$	—	18		figure 26-17



**Figure 26-16 DMAC Single Address Transfer Timing / Two-State Access**

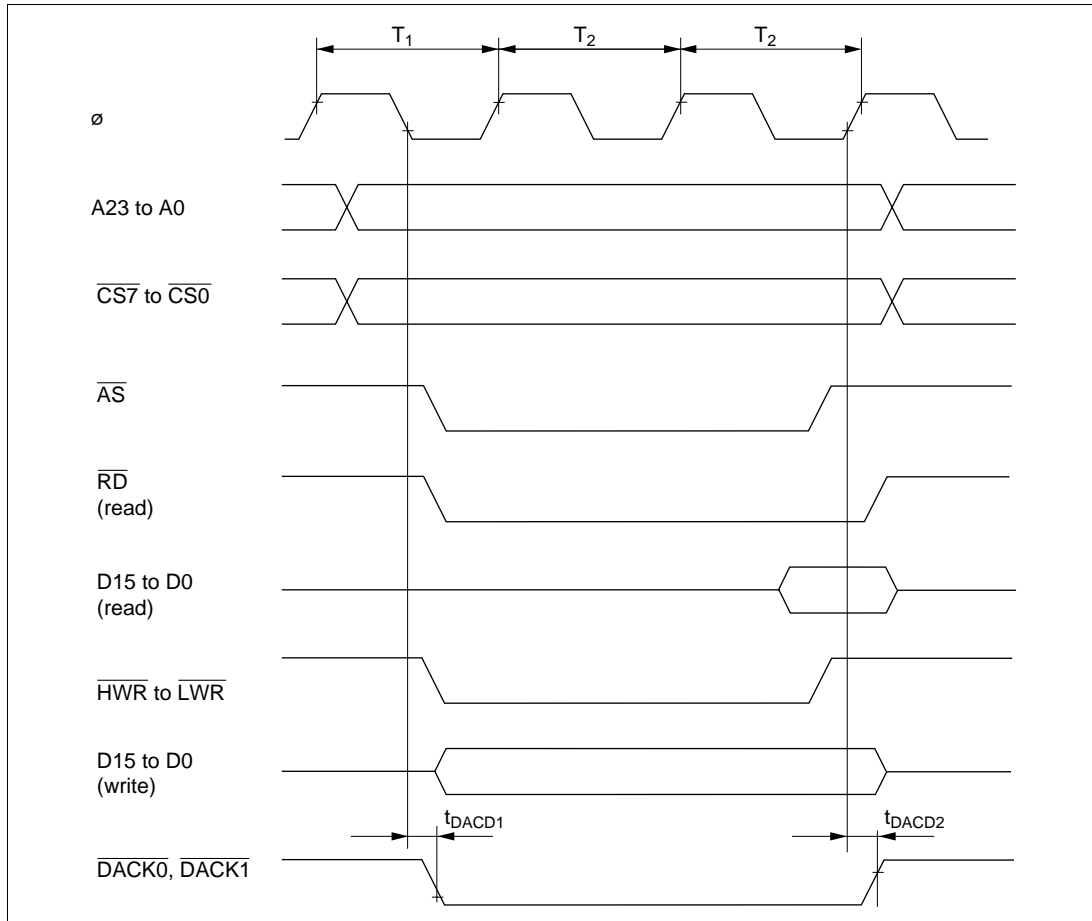


Figure 26-17 DMAC Single Address Transfer Timing / Three-State Access

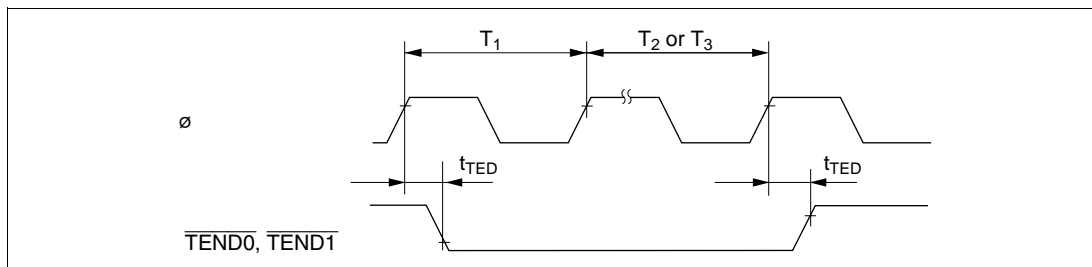
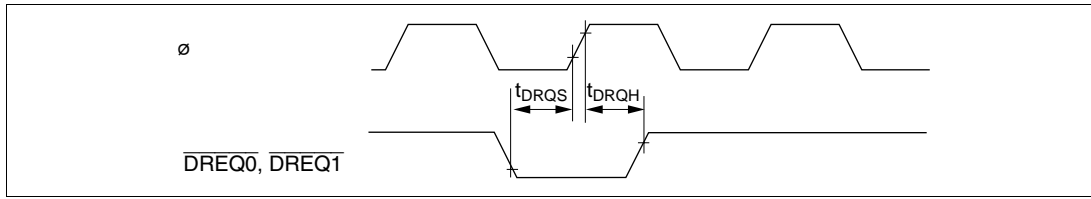


Figure 26-18 DMAC TEND Output Timing



**Figure 26-19 DMAC DREQ Input Timing**



### 26.3.5 Timing of On-Chip Supporting Modules

Table 26-9 lists the timing of on-chip supporting modules.

**Table 26-9 Timing of On-Chip Supporting Modules**

Condition:  $PV_{CC} = 4.5\text{ V to }5.5\text{ V}$ ,  $AV_{CC} = 4.5\text{ V to }5.5\text{ V}$ ,  $V_{ref} = 4.5\text{ V to }AV_{CC}$ ,  
 $V_{SS} = AV_{SS} = PLLV_{SS} = 0\text{ V}$ ,  $\phi = 32.768\text{ kHz}^*$ , 2 to 28 MHz,  
 $T_a = -20^\circ\text{C to }+75^\circ\text{C}$  (regular specifications),  $T_a = -40^\circ\text{C to }+85^\circ\text{C}$  (wide-range specifications)

Item		Symbol	Min	Max	Unit	Test Conditions	
I/O port	Output data delay time	$t_{PWD}$	—	40	ns	Figure 26-20	
	Input data setup time	$t_{PRS}$	25	—			
	Input data hold time	$t_{PRH}$	25	—			
PPG	Pulse output delay time	$t_{POD}$	—	40	ns	Figure 26-21	
TPU	Timer output delay time	$t_{TOCD}$	—	40	ns	Figure 26-22	
	Timer input setup time	$t_{TICS}$	25	—			
	Timer clock input setup time	$t_{TCKS}$	25	—	ns	Figure 26-23	
	Timer clock pulse width	Single edge Both edges	$t_{TCKWH}$ $t_{TCKWL}$	1.5 2.5	—	$t_{cyc}$	
TMR	Timer output delay time	$t_{TMOD}$	—	40	ns	Figure 26-24	
	Timer reset input setup time	$t_{TMRS}$	25	—	ns	Figure 26-26	
	Timer clock input setup time	$t_{TMCS}$	25	—	ns	Figure 26-25	
	Timer clock pulse width	Single edge Both edges	$t_{TMCWH}$ $t_{TMCWL}$	1.5 2.5	—	$t_{cyc}$	
WDT0	Overflow output delay time	$t_{WOVD}$	—	40	ns	Figure 26-27	
WDT1	Buzz output delay time	$t_{BUZD}$	—	40	ns	Figure 26-28	
PWM	Pulse output delay time	$t_{PWOD}$	—	40	ns	Figure 26-29	
SCI	Input clock cycle	Asynchronous	$t_{Scyc}$	4	—	$t_{cyc}$	Figure 26-30
		Synchronous		6	—		
	Input clock pulse width	$t_{SCKW}$	0.4	0.6	$t_{Scyc}$		
	Input clock rise time	$t_{SCKr}$	—	1.5	$t_{cyc}$		
	Input clock fall time	$t_{SCKf}$	—	1.5			

Item		Symbol	Min	Max	Unit	Test Conditions
SCI	Transmit data delay time	$t_{TXD}$	—	40	ns	Figure 26-31
	Receive data setup time (synchronous)	$t_{RXS}$	40	—		
	Receive data hold time (synchronous)	$t_{RXH}$	40	—		
A/D converter	Trigger input setup time	$t_{TRGS}$	40	—	ns	Figure 26-32

Note: \* Only available I/O port, TMR, WDT0, and WDT1.

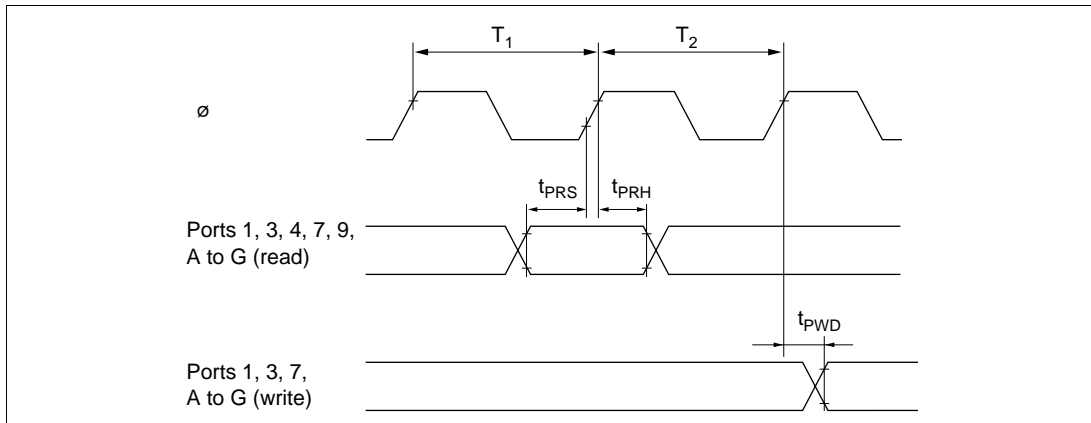


Figure 26-20 I/O Port Input/Output Timing

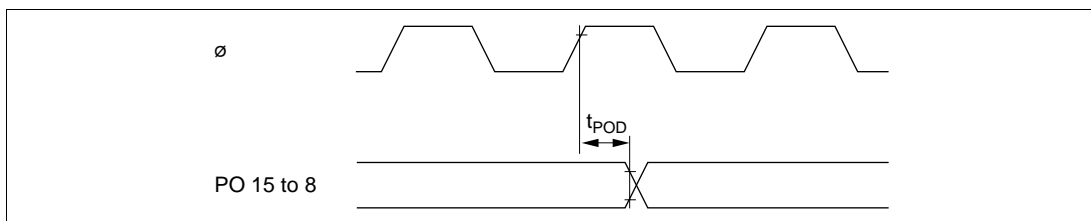
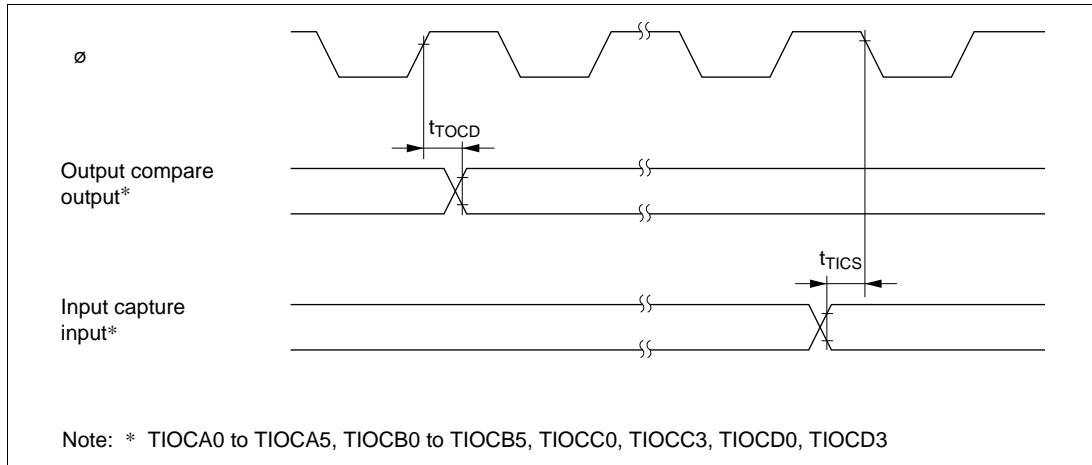
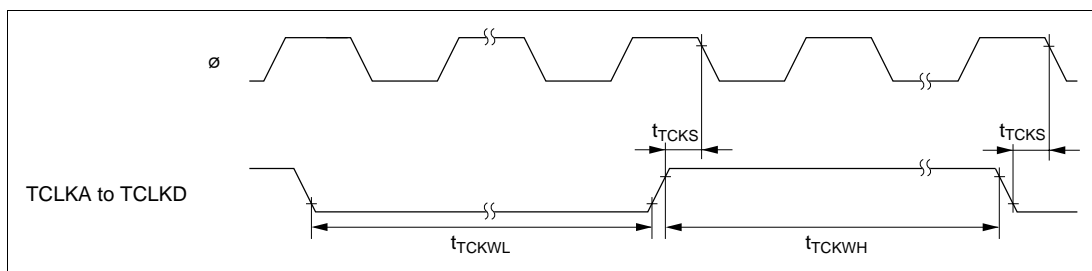


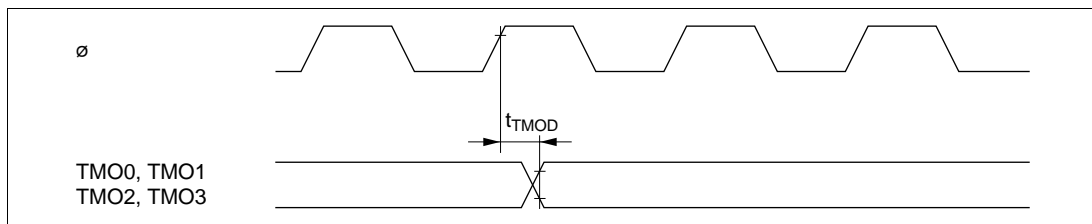
Figure 26-21 PPG Output Timing



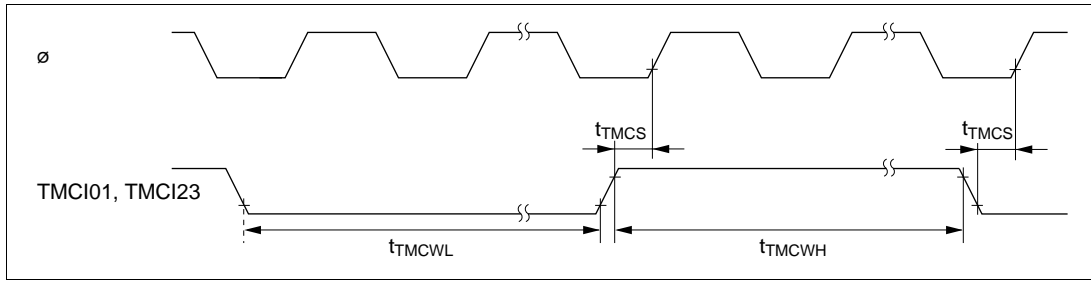
**Figure 26-22 TPU Input/Output Timing**



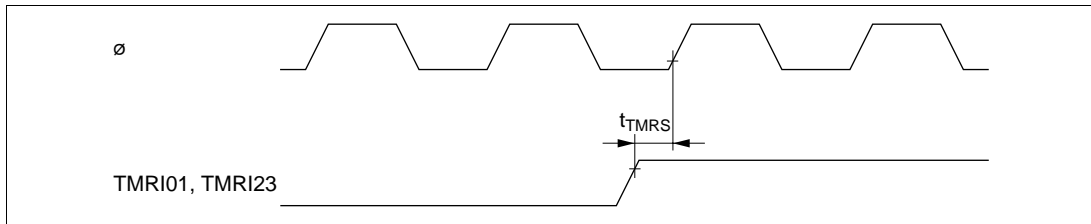
**Figure 26-23 TPU Clock Input Timing**



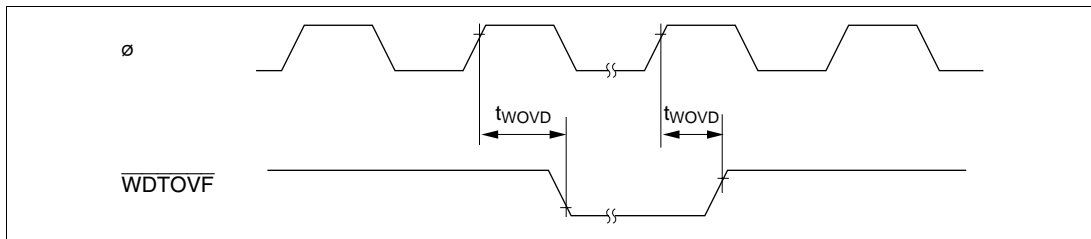
**Figure 26-24 8-bit Timer Output Timing**



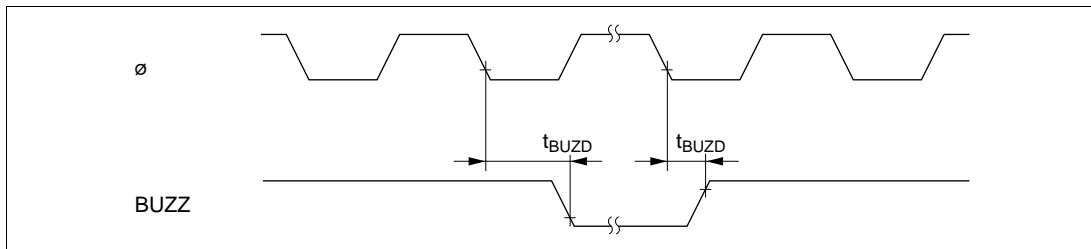
**Figure 26-25 8-bit Timer Clock Input Timing**



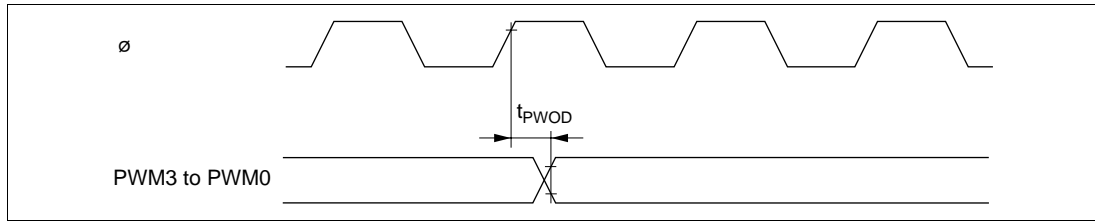
**Figure 26-26 8-bit Timer Reset Input Timing**



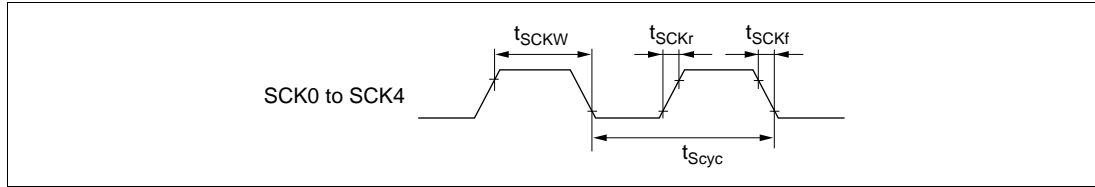
**Figure 26-27 WDT0 Output Timing**



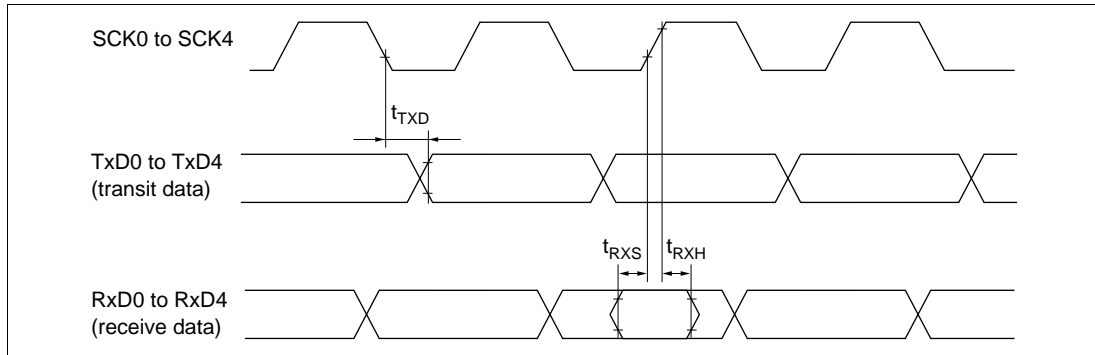
**Figure 26-28 WDT1 Output Timing**



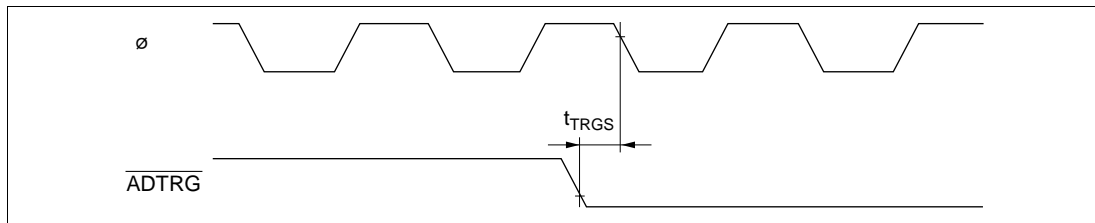
**Figure 26-29 PWM Output Timing**



**Figure 26-30 SCK Clock Input Timing**



**Figure 26-31 SCI Input/Output Timing (Clock Synchronous Mode)**



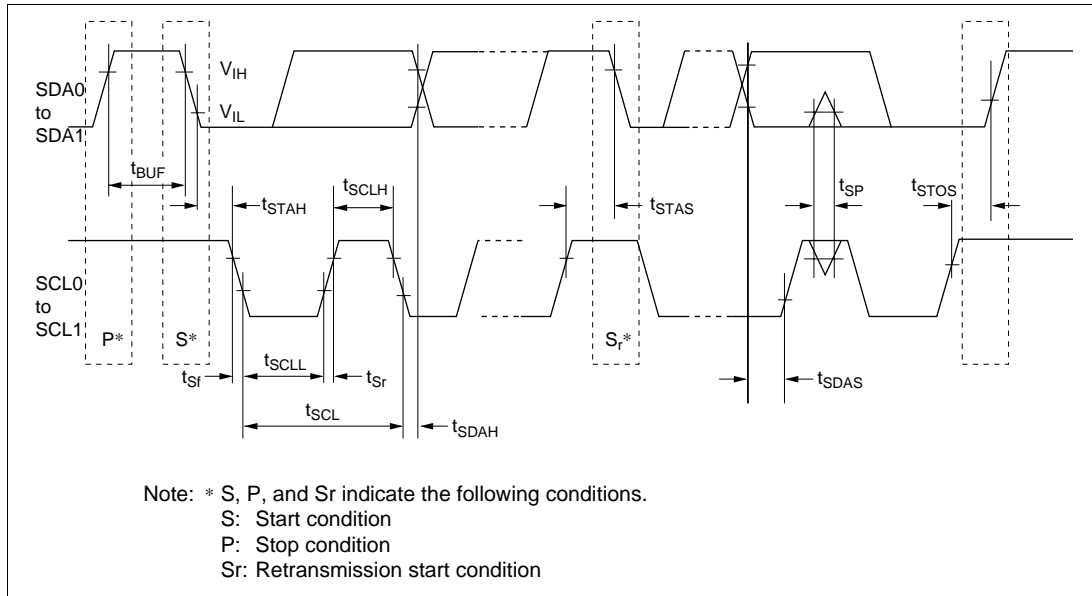
**Figure 26-32 A/D Converter External Trigger Input Timing**

**Table 26-10 I<sup>2</sup>C Bus Timing**

Conditions:  $PV_{CC} = 4.5\text{ V to }5.5\text{ V}$ ,  $V_{SS} = 0\text{ V}$ ,  $\phi = 5\text{ MHz}$  to maximum operating frequency,  $T_a = -20^\circ\text{C to }+75^\circ\text{C}$  (regular specifications),  $T_a = -40^\circ\text{C to }+85^\circ\text{C}$  (wide-range specifications)

Item	Symbol	Ratings			Unit	Notes
		Min	Typ	Max		
SCL input cycle time	$t_{SCL}$	$12t_{cyc}$	—	—	ns	Figure 26-33
SCL input high pulse width	$t_{SCLH}$	$3t_{cyc}$	—	—	ns	
SCL input low pulse width	$t_{SCLL}$	$5t_{cyc}$	—	—	ns	
SCL, SDA input rise time	$t_{Sr}$	—	—	$7.5t_{cyc}^*$	ns	
SCL, SDA input fall time	$t_{Sf}$	—	—	300	ns	
SCL, SDA input spike pulse elimination time	$t_{SP}$	—	—	$1t_{cyc}$	ns	
SDA input bus free time	$t_{BUF}$	$5t_{cyc}$	—	—	ns	
Start condition input hold time	$t_{STAH}$	$3t_{cyc}$	—	—	ns	
Retransmission start condition input setup time	$t_{STAS}$	$3t_{cyc}$	—	—	ns	
Stop condition input setup time	$t_{STOS}$	$3t_{cyc}$	—	—	ns	
Data input setup time	$t_{SDAS}$	$0.5t_{cyc}$	—	—	ns	
Data input hold time	$t_{SDAH}$	0	—	—	ns	
SCL, SDA capacitive load	$C_b$	—	—	400	pF	

Note: \*  $17.5t_{cyc}$  can be set according to the clock selected for use by the I<sup>2</sup>C module. For details, see section 18.4, Usage Notes.



**Figure 26-33 I<sup>2</sup>C Bus Interface Input/Output Timing (Option)**

## 26.4 A/D Conversion Characteristics

Table 26-11 lists the A/D conversion characteristics.

**Table 26-11 A/D Conversion Characteristics**

Condition:  $PV_{CC} = 4.5\text{ V to }5.5\text{ V}$ ,  $AV_{CC} = 4.5\text{ V to }5.5\text{ V}$ ,  $V_{ref} = 4.5\text{ V to }AV_{CC}$ ,  
 $V_{SS} = AV_{SS} = PLLV_{SS} = 0\text{ V}$ ,  $\phi = 2\text{ to }28\text{ MHz}$ ,  $T_a = -20^\circ\text{C to }+75^\circ\text{C}$  (regular  
specifications),  $T_a = -40^\circ\text{C to }+85^\circ\text{C}$  (wide-range specifications)

Item	Min	Typ	Max	Unit
Resolution	10	10	10	bits
Conversion time	10	—	—	$\mu\text{s}$
Analog input capacitance	—	—	20	pF
Permissible signal-source impedance	—	—	5	$\text{k}\Omega$
Nonlinearity error	—	—	$\pm 3.5$	LSB
Offset error	—	—	$\pm 3.5$	LSB
Full-scale error	—	—	$\pm 3.5$	LSB
Quantization	—	$\pm 0.5$	—	LSB
Absolute accuracy	—	—	$\pm 4.0$	LSB



## 26.5 D/A Conversion Characteristics

Table 26-12 shows the D/A conversion characteristics.

**Table 26-12 D/A Conversion Characteristics**

Condition:  $PV_{CC} = 4.5\text{ V to }5.5\text{ V}$ ,  $AV_{CC} = 4.5\text{ V to }5.5\text{ V}$ ,  $V_{ref} = 4.5\text{ V to }AV_{CC}$ ,  
 $V_{SS} = AV_{SS} = PLLV_{SS} = 0\text{ V}$ ,  $\phi = 2\text{ to }28\text{ MHz}$ ,  $T_a = -20^\circ\text{C to }+75^\circ\text{C}$  (regular  
specifications),  $T_a = -40^\circ\text{C to }+85^\circ\text{C}$  (wide-range specifications)

Item	Min	Typ	Max	Unit	Test Conditions
Resolution	8	8	8	bits	
Conversion time	—	—	10	$\mu\text{s}$	20-pF capacitive load
Absolute accuracy	—	$\pm 1.5$	$\pm 2.0$	LSB	2-M $\Omega$ resistive load
	—	—	$\pm 1.5$	LSB	4-M $\Omega$ resistive load

## 26.6 Flash Memory Characteristics

**Table 26-13 Flash Memory Characteristics**

Conditions:  $PV_{CC} = 4.5\text{ V to }5.5\text{ V}$ ,  $AV_{CC} = 4.5\text{ V to }5.5\text{ V}$ ,  $V_{SS} = AV_{SS} = PLLV_{SS} = 0\text{ V}$ ,  
 $T_a = -20^\circ\text{C to }+75^\circ\text{C}$  (regular specifications),  $T_a = -40^\circ\text{C to }+85^\circ\text{C}$  (wide-range specifications)

Item	Symbol	Min	Typ	Max	Unit	
Programming time* <sup>1</sup> * <sup>2</sup> * <sup>4</sup>	$t_P$	—	10	200	ms/128 bytes	
Erase time* <sup>1</sup> * <sup>3</sup> * <sup>5</sup>	$t_E$	—	50	1000	ms/block	
Number of rewrites	$N_{WEC}$	—	—	100	Times	
Programming	Wait time after SWE1 bit setting* <sup>1</sup>	x0	1	—	—	$\mu\text{s}$
	Wait time after PSU1 bit setting* <sup>1</sup>	y	50	—	—	$\mu\text{s}$
	Wait time after P1 bit setting* <sup>1</sup> * <sup>4</sup>	z0	—	—	30	$\mu\text{s}$
		z1	—	—	10	$\mu\text{s}$
		z2	—	—	200	$\mu\text{s}$
	Wait time after P1 bit clearing* <sup>1</sup>	$\alpha$	5	—	—	$\mu\text{s}$
	Wait time after PSU1 bit clearing* <sup>1</sup>	$\beta$	5	—	—	$\mu\text{s}$
	Wait time after PV1 bit setting* <sup>1</sup>	$\gamma$	4	—	—	$\mu\text{s}$
	Wait time after H'FF dummy write* <sup>1</sup>	$\varepsilon$	2	—	—	$\mu\text{s}$
	Wait time after PV1 bit clearing* <sup>1</sup>	$\eta$	2	—	—	$\mu\text{s}$
		Maximum number of writes* <sup>1</sup> * <sup>4</sup>	N1	—	—	6
	N2		—	—	994	Times
Common	Wait time after SWE1 bit clearing* <sup>1</sup>	x1	100	—	—	$\mu\text{s}$
Erasing	Wait time after SWE1 bit setting* <sup>1</sup>	x	1	—	—	$\mu\text{s}$
	Wait time after ESU1 bit setting* <sup>1</sup>	y	100	—	—	$\mu\text{s}$
	Wait time after E1 bit setting* <sup>1</sup> * <sup>5</sup>	z	—	—	10	ms
	Wait time after E1 bit clearing* <sup>1</sup>	$\alpha$	10	—	—	$\mu\text{s}$
	Wait time after ESU1 bit clearing* <sup>1</sup>	$\beta$	10	—	—	$\mu\text{s}$
	Wait time after EV1 bit setting* <sup>1</sup>	$\gamma$	6	—	—	$\mu\text{s}$
	Wait time after H'FF dummy write* <sup>1</sup>	$\varepsilon$	2	—	—	$\mu\text{s}$
	Wait time after EV1 bit clearing* <sup>1</sup>	$\eta$	4	—	—	$\mu\text{s}$
	Maximum number of erases* <sup>1</sup> * <sup>5</sup>	N	—	—	100	Times

Notes: \*1 Follow the program/erase algorithms when making the time settings.

\*2 Programming time per 128 bytes. (Indicates the total time during which the P1 bit is set in flash memory control register 1 (FLMCR1). Does not include the program-verify time.)

- \*3 Time to erase one block. (Indicates the time during which the E1 bit is set in FLMCR1. Does not include the erase-verify time.)
- \*4 Maximum programming time  
( $t_P(\text{max}) = \text{Wait time after P1 bit setting (z)} \times \text{maximum number of writes (N)}$ )  
( $z_0 + z_1) \times 6 + z_2 \times 994$ )
- \*5 Maximum erase time  
( $t_E(\text{max}) = \text{Wait time after E1 bit setting (z)} \times \text{maximum number of erases (N)}$ )

## 26.7 Usage Note

Although both the F-ZTAT and mask ROM versions fully meet the electrical specifications listed in this manual, due to differences in the fabrication process, the on-chip ROM, and the layout patterns, there will be differences in the actual values of the electrical characteristics, the operating margins, the noise margins, and other aspects.

Therefore, if a system is evaluated using the F-ZTAT version, a similar evaluation should also be performed using the mask ROM version.



## Section 27 Electrical Characteristics (H8S/2695)

### 27.1 Absolute Maximum Ratings

Table 27-1 lists the absolute maximum ratings. Unless specified otherwise,  $PV_{CC}$  refers to both  $PV_{CC1}$  and  $PV_{CC2}$ .

**Table 27-1 Absolute Maximum Ratings**

Item	Symbol	Value	Unit
Power supply voltage	$PV_{CC}$	-0.3 to +7.0	V
Input voltage (ports 4 and 9)	$V_{in}$	-0.3 to $AV_{CC} + 0.3$	V
Input voltage (except ports 4 and 9)	$V_{in}$	-0.3 to $PV_{CC} + 0.3$	V
Reference voltage	$V_{ref}$	-0.3 to $AV_{CC} + 0.3$	V
Analog power supply voltage	$AV_{CC}$	-0.3 to +7.0	V
Analog input voltage	$V_{AN}$	-0.3 to $AV_{CC} + 0.3$	V
Operating temperature	$T_{opr}$	Regular specifications: -20 to +75	°C
		Wide-range specifications: -40 to +85	°C
Storage temperature	$T_{stg}$	-55 to +125	°C

Caution: Permanent damage to the chip may result if absolute maximum rating are exceeded.

## 27.2 DC Characteristics

Table 27-2 lists the DC characteristics. Table 27-3 lists the permissible output currents.

**Table 27-2 DC Characteristics**

Conditions:  $PV_{CC} = 4.5\text{ V to }5.5\text{ V}$ ,  $AV_{CC} = 4.5\text{ V to }5.5\text{ V}$ ,  $V_{ref} = 4.5\text{ V to }AV_{CC}$ ,  
 $V_{SS} = AV_{SS} = PLLV_{SS} = 0\text{ V}$ ,  $T_a = -20^\circ\text{C to }+75^\circ\text{C}$  (regular specifications),  
 $T_a = -40^\circ\text{C to }+85^\circ\text{C}$  (wide-range specifications)\*<sup>1</sup>

Item	Symbol	Min	Typ	Max	Unit	Test Conditions	
Schmitt trigger input voltage	$\overline{IRQ7}$ to $\overline{IRQ0}$	$V_T^-$	1.0	—	—	V	
		$V_T^+$	—	—	$PV_{CC} \times 0.7$	V	
		$V_T^+ - V_T^-$	0.4	—	—	V	
Input high voltage	$\overline{RES}$ , $\overline{STBY}$ , NMI, MD2 to MD0	$V_{IH}$	$PV_{CC} - 0.7$	—	$PV_{CC} + 0.3$	V	
	Ports 1, 3, 7, A to G		2.2	—	$PV_{CC} + 0.3$	V	
	Ports 4 and 9		$AV_{CC} \times 0.7$	—	$AV_{CC} + 0.3$	V	
	EXTAL		$PV_{CC} \times 0.8$	—	$PV_{CC} + 0.3$	V	
Input low voltage	$\overline{RES}$ , $\overline{STBY}$ , NMI, MD2 to MD0	$V_{IL}$	-0.3	—	0.5	V	
	Ports 1, 3, 4, 7, 9, A to G		-0.3	—	0.8	V	
	EXTAL		-0.3	—	$PV_{CC} \times 0.2$	V	
Output high voltage	All output pins	$V_{OH}$	$PV_{CC} - 0.5$	—	—	V	$I_{OH} = -200\ \mu\text{A}$
			3.5	—	—	V	$I_{OH} = -1\ \text{mA}$
Output low voltage	All output pins	$V_{OL}$	—	—	0.4	V	$I_{OL} = 1.6\ \text{mA}$
Input leakage current	$\overline{RES}$	$ I_{in} $	—	—	1.0	$\mu\text{A}$	$V_{in} = 0.5\ \text{V to }PV_{CC} - 0.5\ \text{V}$
	$\overline{STBY}$ , NMI, MD2 to MD0		—	—	1.0	$\mu\text{A}$	
	Ports 4, 9		—	—	1.0	$\mu\text{A}$	$V_{in} = 0.5\ \text{V to }AV_{CC} - 0.5\ \text{V}$
Three-state leakage current (off state)	Ports 1, 3, 7, A to G	$ I_{TSL} $	—	—	1.0	$\mu\text{A}$	$V_{in} = 0.5\ \text{V to }PV_{CC} - 0.5\ \text{V}$

Item		Symbol	Min	Typ	Max	Unit	Test Conditions
MOS input pull-up current	Ports A to E	$-I_p$	50	—	300	$\mu\text{A}$	$V_{in} = 0\text{ V}$
Input capacitance	RES	$C_{in}$	—	—	30	pF	$V_{in} = 0\text{ V}$
	NMI		—	—	30	pF	$f = 1\text{ MHz}$
	All input pins except RES and NMI		—	—	15	pF	$T_a = 25^\circ\text{C}$
Current dissipation*2	Normal operation	$I_{CC}^{*4}$	—	70	84	mA	$f = 28\text{ MHz}$
	Sleep mode		—	55	77	mA	$f = 28\text{ MHz}$
	All modules stopped		—	40	—	mA	$f = 28\text{ MHz}$ (reference values)
	Medium-speed mode ( $\phi/32$ )		—	54	—	mA	$f = 28\text{ MHz}$ (reference values)
	Standby mode		—	0.1	5.0	$\mu\text{A}$	$T_a \leq 50^\circ\text{C}$ $50^\circ\text{C} < T_a$
Analog power supply current	During A/D conversion	$AI_{CC}$	—	0.6	2.0	mA	$AV_{CC} = 5.0\text{ V}$
	Idle		—	0.1	5.0	$\mu\text{A}$	$T_a = 25^\circ\text{C}$
Reference power supply current	During A/D conversion	$AI_{CC}$	—	4.0	5.0	mA	$V_{ref} = 5.0\text{ V}$
	Idle		—	0.1	5.0	$\mu\text{A}$	$T_a = 25^\circ\text{C}$
RAM standby voltage*3		$V_{RAM}$	2.0	—	—	V	

Notes: \*1 If the A/D converter is not used, do not leave the  $AV_{CC}$ ,  $V_{ref}$ , and  $AV_{SS}$  pins open. Apply a voltage between 3.3 V and 5.5 V to the  $AV_{CC}$  and  $V_{ref}$  pins by connecting them to  $PV_{CC}$ , for instance. Set  $V_{ref} \leq AV_{CC}$ .

\*2 Current dissipation values are for  $V_{IH} = AV_{CC}$  (ports 4 and 9), or  $PV_{CC}$  (other), and  $V_{IL} = 0\text{ V}$ , with all output pins unloaded and the on-chip MOS pull-up transistors in the off state.

\*3 The values are for  $V_{RAM} \leq PV_{CC} < 3.0\text{ V}$ ,  $V_{IH\ min} = PV_{CC} - 0.1\text{ V}$ , and  $V_{IL\ max} = 0.1\text{ V}$ .

\*4  $I_{CC}$  depends on  $PV_{CC}$  and  $f$  as follows:

$$I_{CC\ max} = 15\text{ (mA)} + 0.45\text{ (mA/(MHz} \times \text{V))} \times PV_{CC} \times f\text{ (normal operation)}$$

$$I_{CC\ max} = 15\text{ (mA)} + 0.40\text{ (mA/(MHz} \times \text{V))} \times PV_{CC} \times f\text{ (sleep mode)}$$

**Table 27-3 Permissible Output Currents**

Conditions:  $PV_{CC} = 4.5\text{ V to }5.5\text{ V}$ ,  $AV_{CC} = 4.5\text{ V to }5.5\text{ V}$ ,  $V_{ref} = 4.5\text{ V to }AV_{CC}$ ,  
 $V_{SS} = AV_{SS} = PLLV_{SS} = 0\text{ V}$ ,  $T_a = -20^\circ\text{C to }+75^\circ\text{C}$  (regular specifications),  
 $T_a = -40^\circ\text{C to }+85^\circ\text{C}$  (wide-range specifications)

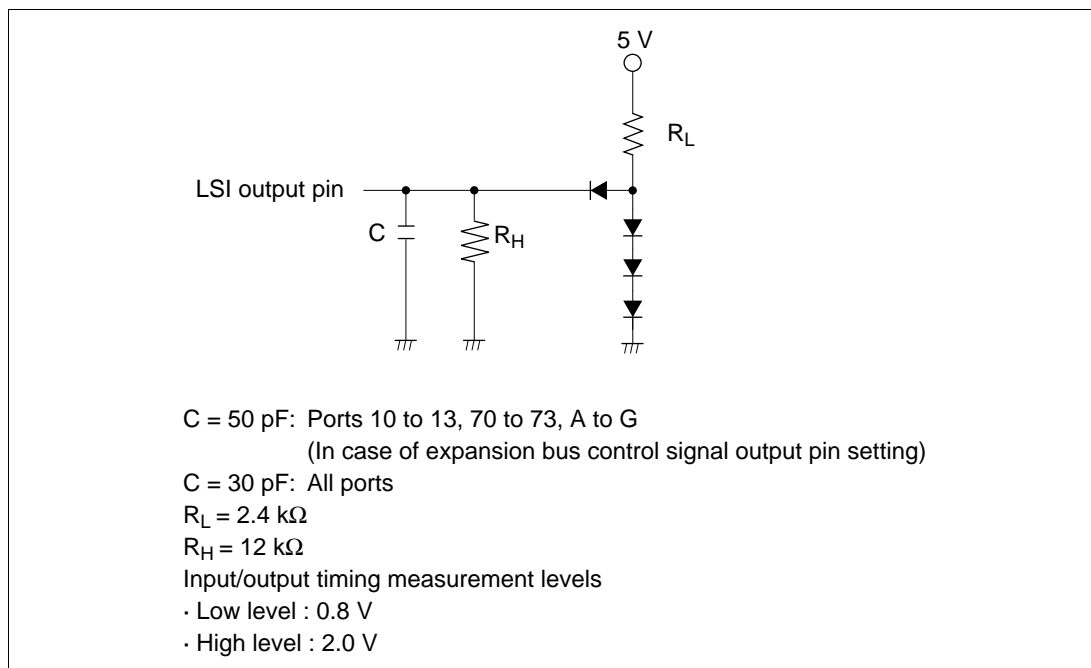
Item			Symbol	Min	Typ	Max	Unit
Permissible output low current (per pin)	All output pins	$PV_{CC} = 4.5\text{ V to }5.5\text{ V}$	$I_{OL}$	—	—	10	mA
Permissible output low current (total)	Total of all output pins	$PV_{CC} = 4.5\text{ V to }5.5\text{ V}$	$\sum I_{OL}$	—	—	120	mA
Permissible output high current (per pin)	All output pins	$PV_{CC} = 4.5\text{ V to }5.5\text{ V}$	$-I_{OH}$	—	—	2.0	mA
Permissible output high current (total)	Total of all output pins	$PV_{CC} = 4.5\text{ V to }5.5\text{ V}$	$\sum -I_{OH}$	—	—	40	mA

Note: To protect chip reliability, do not exceed the output current values in table 27-3.



## 27.3 AC Characteristics

Figure 27-1 show, the test conditions for the AC characteristics.



**Figure 27-1 Output Load Circuit**

### 27.3.1 Clock Timing

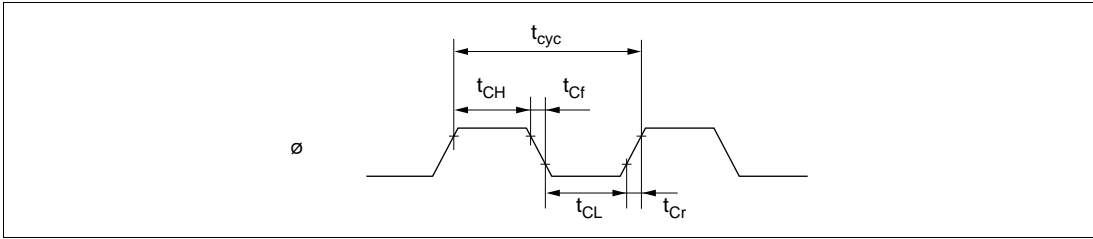
Table 27-4 lists the clock timing

**Table 27-4 Clock Timing**

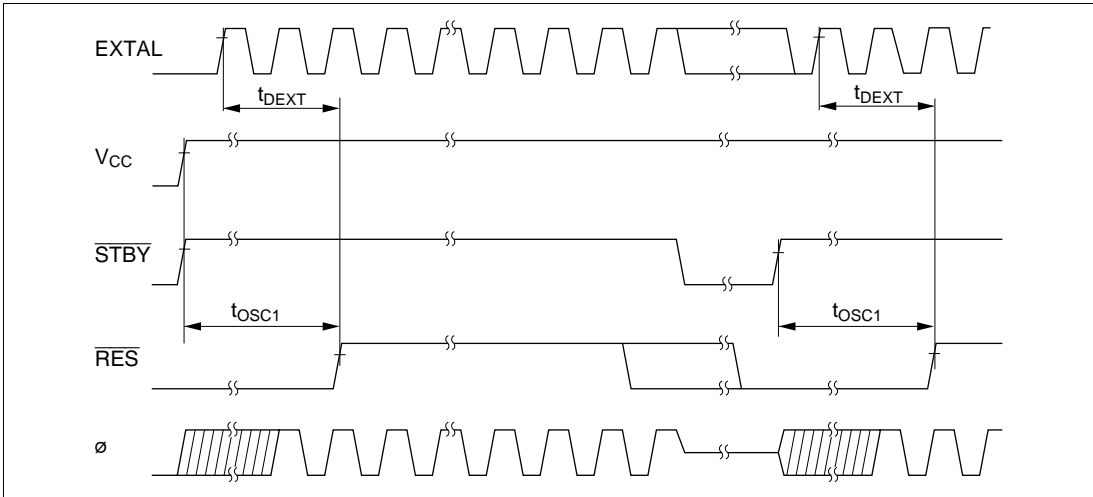
Condition:  $PV_{CC} = 4.5\text{ V to }5.5\text{ V}$ ,  $AV_{CC} = 4.5\text{ V to }5.5\text{ V}$ ,  $V_{ref} = 4.5\text{ V to }AV_{CC}$ ,  
 $V_{SS} = AV_{SS} = 0\text{ V}$ ,  $\phi = 2\text{ to }28\text{ MHz}^*$ ,  $T_a = -20^\circ\text{C to }+75^\circ\text{C}$  (regular specifications),  
 $T_a = -40^\circ\text{C to }+85^\circ\text{C}$  (wide-range specifications)

Item	Symbol	28MHz		Unit	Test Conditions
		Min	Max		
Clock cycle time	$t_{cyc}$	35.7	500	ns	Figure 27-2
Clock high pulse width	$t_{CH}$	10	—	ns	
Clock low pulse width	$t_{CL}$	10	—	ns	
Clock rise time	$t_{Cr}$	—	5	ns	
Clock fall time	$t_{Cf}$	—	5	ns	
Clock oscillator settling time at reset (crystal)	$t_{OSC1}$	10	—	ms	Figure 27-3
Clock oscillator settling time in software standby (crystal)	$t_{OSC2}$	5	—	ms	Figure 24-3
External clock output stabilization delay time	$t_{DEXT}$	2	—	ms	Figure 27-3

Note: \* The input clock frequency should be set to 25 MHz or less. If  $\phi = 25\text{ MHz to }28\text{ MHz}$ , use the PLL to multiply the frequency ( $\times 2$  or  $\times 4$ ).



**Figure 27-2 System Clock Timing**



**Figure 27-3 Oscillator Settling Timing**

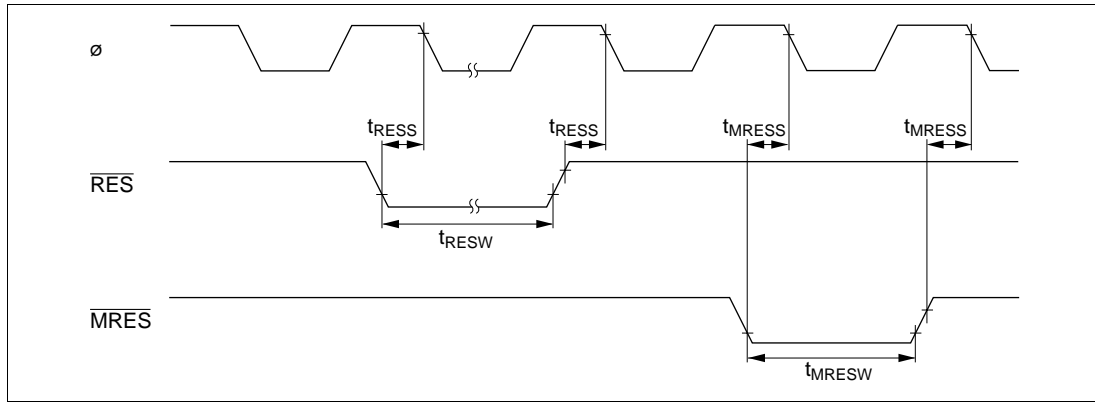
### 27.3.2 Control Signal Timing

Table 27-5 lists the control signal timing.

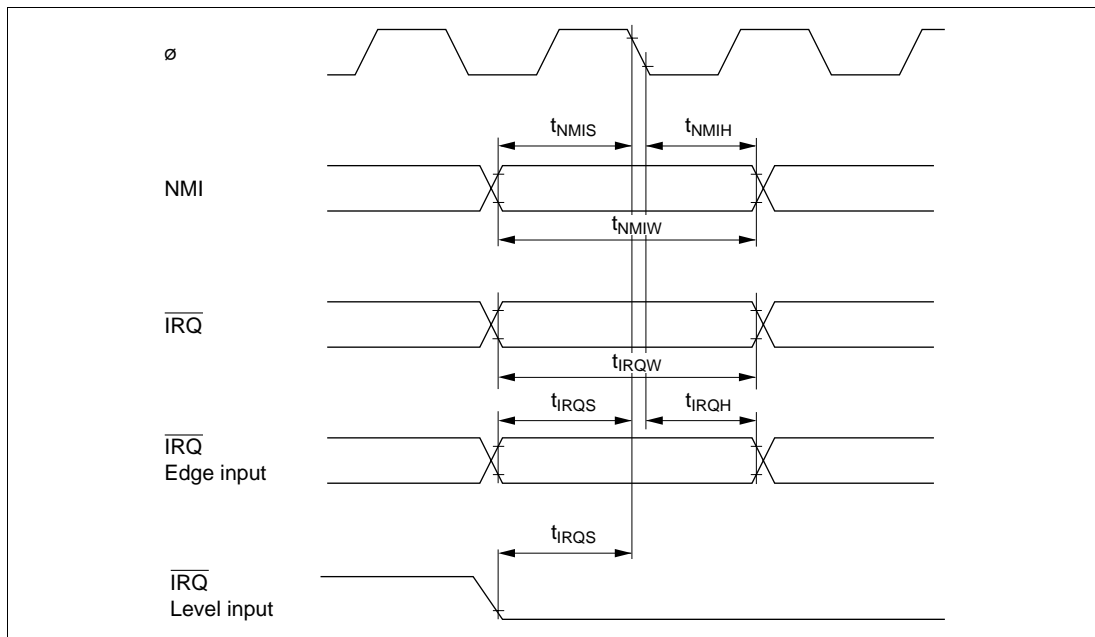
**Table 27-5 Control Signal Timing**

Condition:  $PV_{CC} = 4.5\text{ V to }5.5\text{ V}$ ,  $AV_{CC} = 4.5\text{ V to }5.5\text{ V}$ ,  $V_{ref} = 4.5\text{ V to }AV_{CC}$ ,  
 $V_{SS} = AV_{SS} = PLLV_{SS} = 0\text{ V}$ ,  $\phi = 2\text{ to }28\text{ MHz}$ ,  $T_a = -20^\circ\text{C to }+75^\circ\text{C}$  (regular specifications),  $T_a = -40^\circ\text{C to }+85^\circ\text{C}$  (wide-range specifications)

Item	Symbol	Min	Max	Unit	Test Conditions
$\overline{\text{RES}}$ setup time	$t_{\text{RESS}}$	200	—	ns	Figure 27-4
$\overline{\text{RES}}$ pulse width	$t_{\text{RESW}}$	20	—	$t_{\text{cyc}}$	
$\overline{\text{MRES}}$ setup time	$t_{\text{MRESS}}$	250	—	ns	
$\overline{\text{MRES}}$ pulse width	$t_{\text{MRESW}}$	20	—	$t_{\text{cyc}}$	
NMI setup time	$t_{\text{NMIS}}$	150	—	ns	Figure 27-5
NMI hold time	$t_{\text{NMIH}}$	10	—		
NMI pulse width (exiting software standby mode)	$t_{\text{NMIW}}$	200	—	ns	
$\overline{\text{IRQ}}$ setup time	$t_{\text{IRQS}}$	150	—	ns	
$\overline{\text{IRQ}}$ hold time	$t_{\text{IRQH}}$	10	—	ns	
$\overline{\text{IRQ}}$ pulse width (exiting software standby mode)	$t_{\text{IRQW}}$	200	—	ns	



**Figure 27-4 Reset Input Timing**



**Figure 27-5 Interrupt Input Timing**

### 27.3.3 Bus Timing

Table 27-6 lists the bus timing.

**Table 27-6 Bus Timing**

Condition:  $PV_{CC} = 4.5\text{ V to }5.5\text{ V}$ ,  $AV_{CC} = 4.5\text{ V to }5.5\text{ V}$ ,  $V_{ref} = 4.5\text{ V to }AV_{CC}$ ,  
 $V_{SS} = AV_{SS} = PLLV_{SS} = 0\text{ V}$ ,  $\phi = 2\text{ to }28\text{ MHz}$ ,  $T_a = -20^\circ\text{C to }+75^\circ\text{C}$  (regular specifications),  $T_a = -40^\circ\text{C to }+85^\circ\text{C}$  (wide-range specifications)

Item	Symbol	Min	Max	Unit	Test Conditions
Address delay time	$t_{AD}$	—	20	ns	Figure 27-6 to
Address setup time	$t_{AS}$	$0.5 \times t_{cyc} - 13$	—	ns	figure 27-10
Address hold time	$t_{AH}$	$0.5 \times t_{cyc} - 8$	—	ns	
$\overline{CS}$ delay time 1	$t_{CSD1}$	—	15	ns	
$\overline{CS}$ delay time 2	$t_{CSD2}$	—	15	ns	
$\overline{AS}$ delay time	$t_{ASD}$	—	15	ns	
$\overline{RD}$ delay time 1	$t_{RSD1}$	—	15	ns	
$\overline{RD}$ delay time 2	$t_{RSD2}$	—	15	ns	
Read data setup time	$t_{RDS}$	15	—	ns	
Read data hold time	$t_{RDH}$	0	—	ns	
Read data access time 1	$t_{ACC1}$	—	$1.0 \times t_{cyc} - 15$	ns	
Read data access time 2	$t_{ACC2}$	—	$1.5 \times t_{cyc} - 15$	ns	
Read data access time 3	$t_{ACC3}$	—	$2.0 \times t_{cyc} - 15$	ns	
Read data access time 4	$t_{ACC4}$	—	$2.5 \times t_{cyc} - 15$	ns	
Read data access time 5	$t_{ACC5}$	—	$3.0 \times t_{cyc} - 15$	ns	
$\overline{WR}$ delay time 1	$t_{WRD1}$	—	15	ns	
$\overline{WR}$ delay time 2	$t_{WRD2}$	—	15	ns	
$\overline{WR}$ pulse width 1	$t_{WSW1}$	$1.0 \times t_{cyc} - 13$	—	ns	
$\overline{WR}$ pulse width 2	$t_{WSW2}$	$1.5 \times t_{cyc} - 13$	—	ns	
Write data delay time	$t_{WDD}$	—	22	ns	
Write data setup time	$t_{WDS}$	$0.5 \times t_{cyc} - 13$	—	ns	
Write data hold time	$t_{WDH}$	$0.5 \times t_{cyc} - 8$	—	ns	
$\overline{WR}$ setup time	$t_{WCS}$	$0.5 \times t_{cyc} - 10$	—	ns	
$\overline{WR}$ hold time	$t_{WCH}$	$0.5 \times t_{cyc} - 10$	—	ns	

Item	Symbol	Min	Max	Unit	Conditions
WAIT setup time	$t_{WTS}$	25	—	ns	Figure 27-8
WAIT hold time	$t_{WTH}$	5	—	ns	
BREQ setup time	$t_{BRQS}$	30	—	ns	Figure 27-11
BACK delay time	$t_{BACD}$	—	15	ns	
Bus-floating time	$t_{BZD}$	—	40	ns	
BREQO delay time	$t_{BRQOD}$	—	25	ns	Figure 27-12

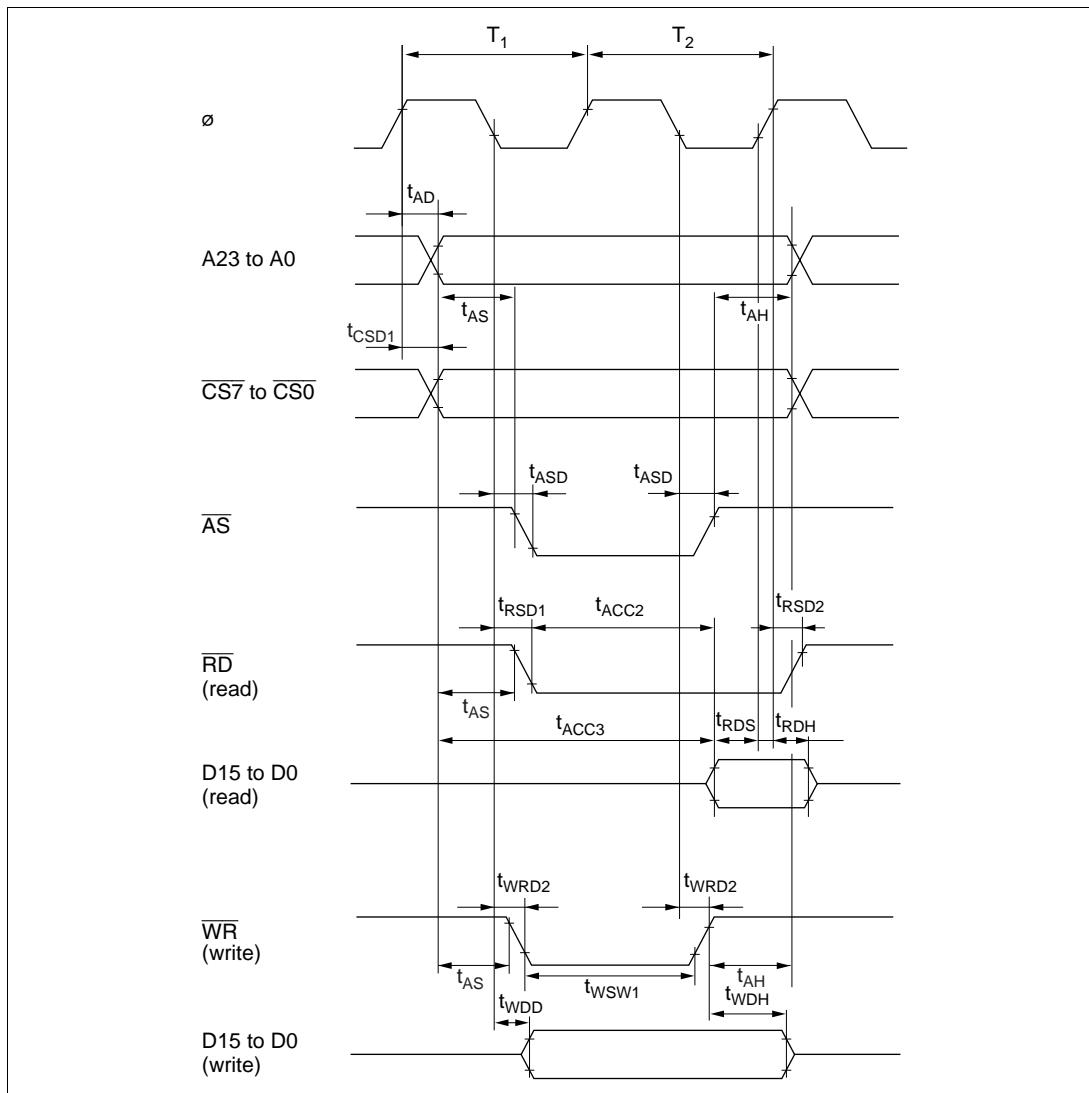


Figure 27-6 Basic Bus Timing (Two-State Access)

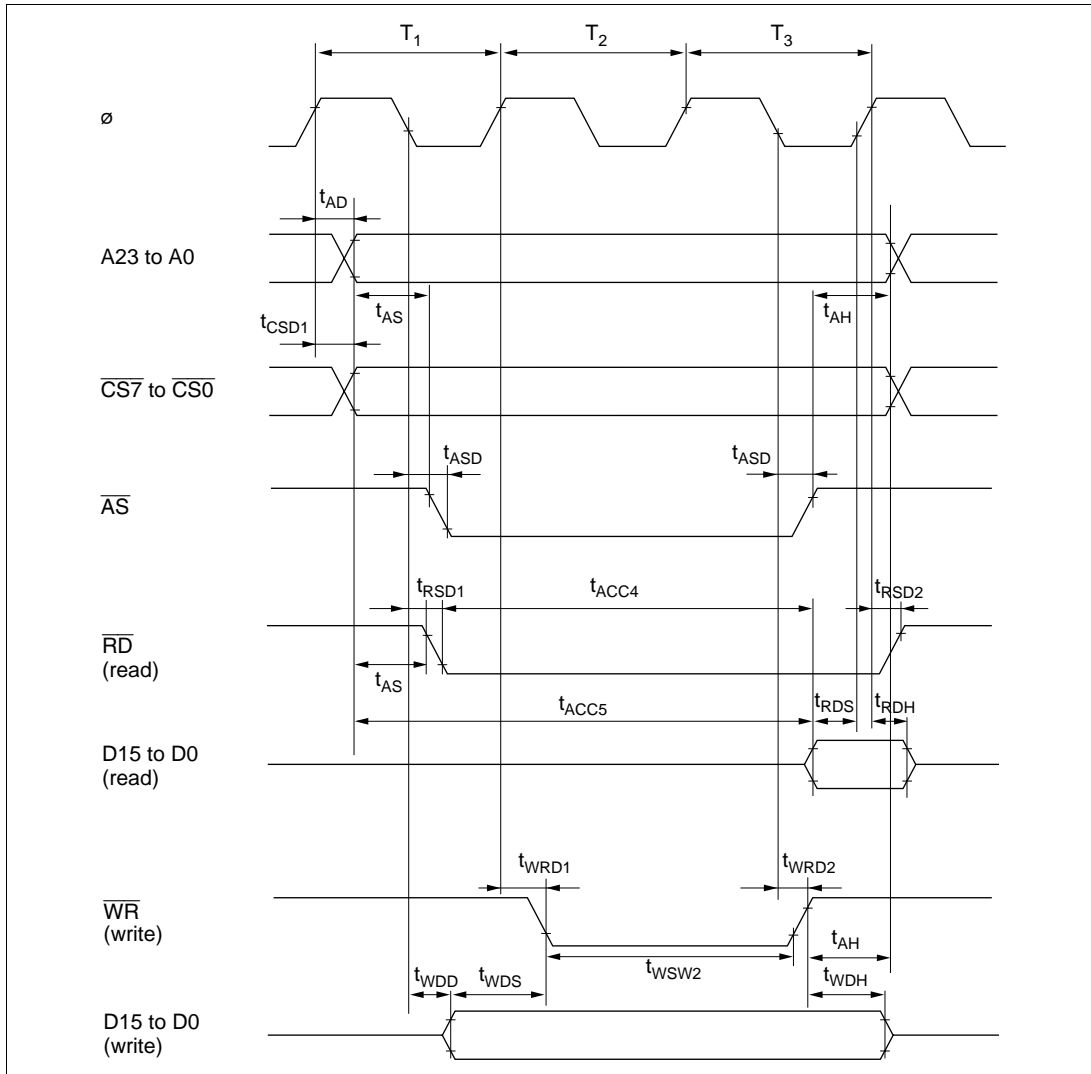


Figure 27-7 Basic Bus Timing (Three-State Access)



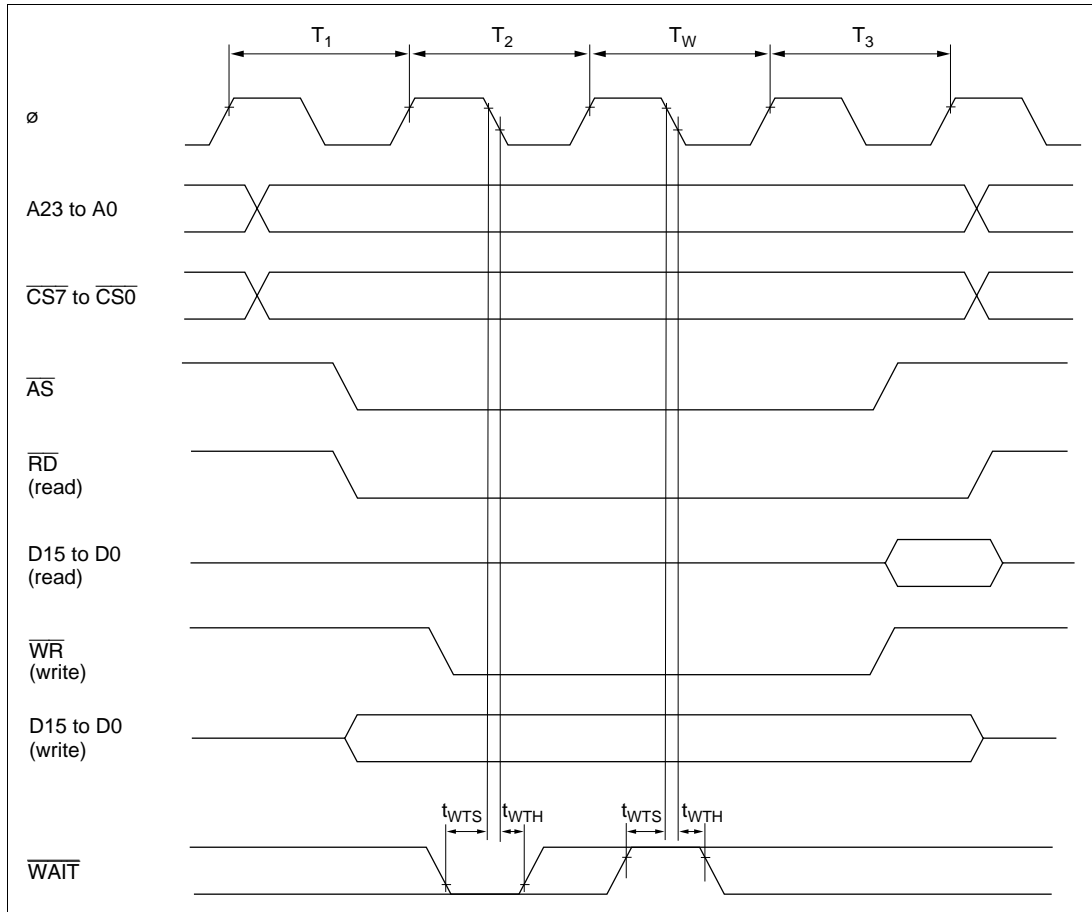
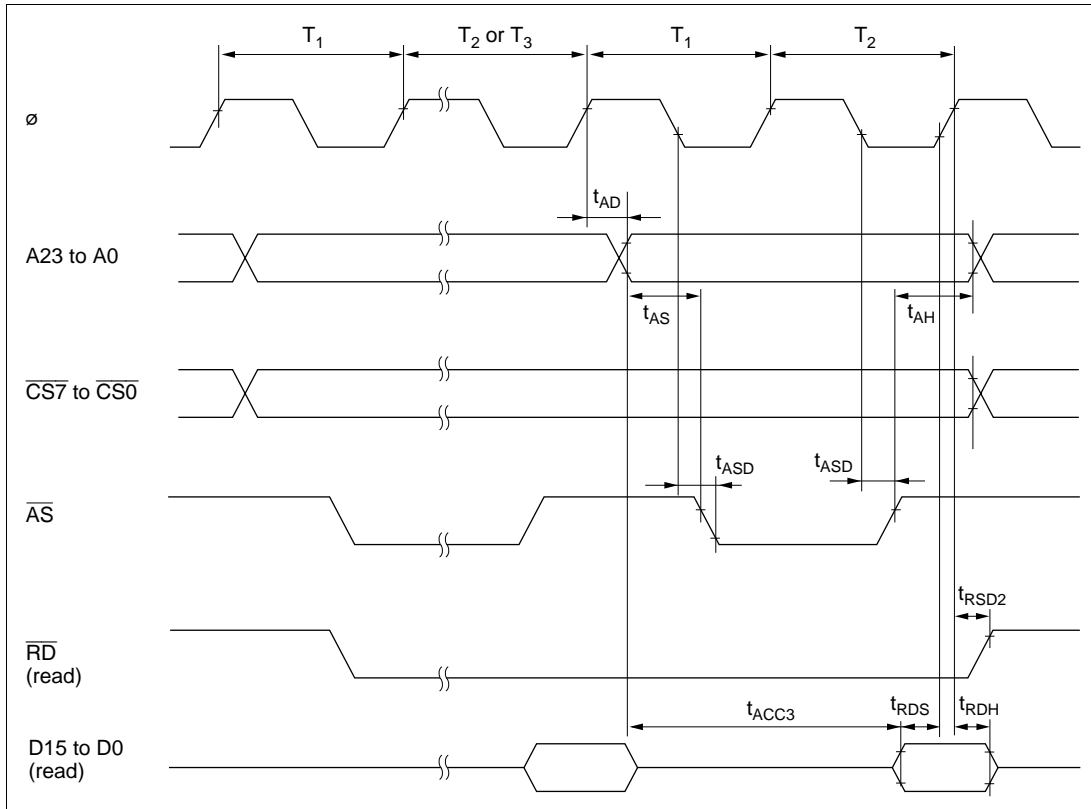
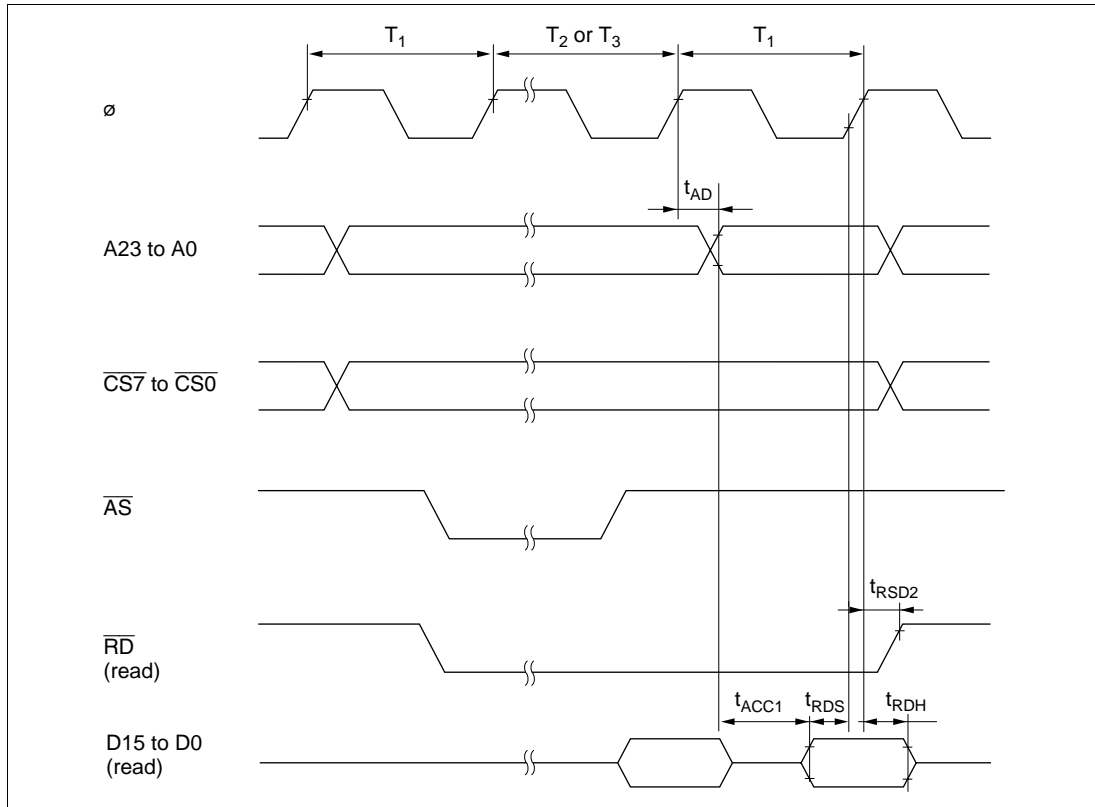


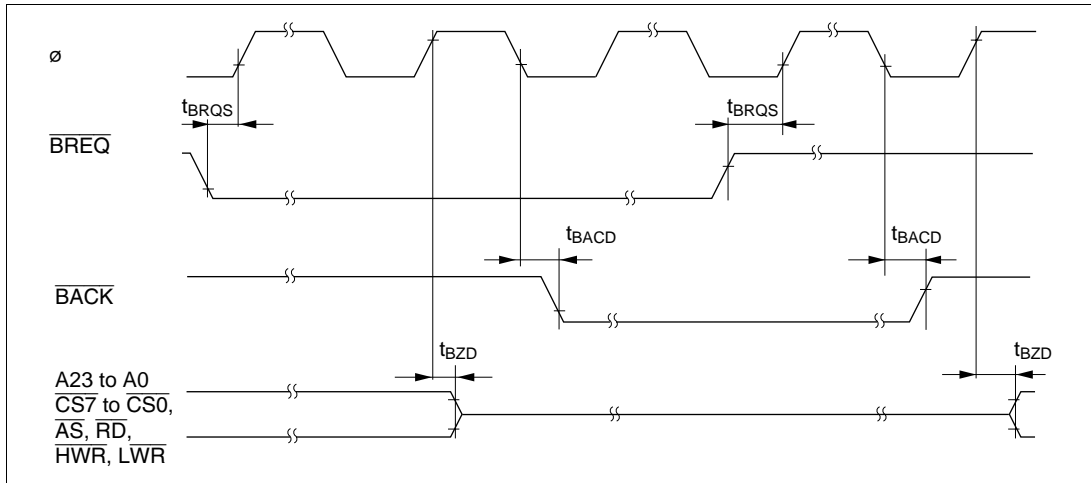
Figure 27-8 Basic Bus Timing (Three-State Access with One Wait State)



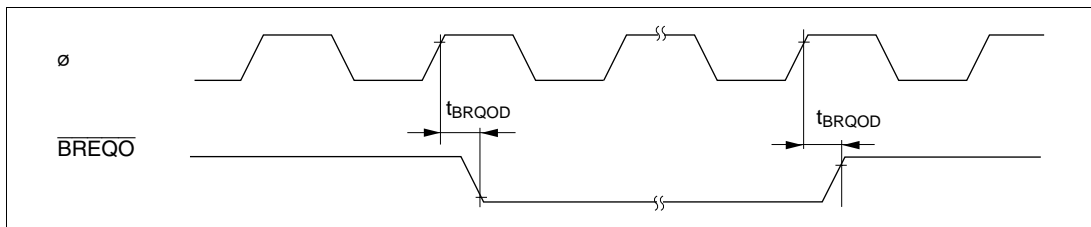
**Figure 27-9 Burst ROM Access Timing (Two-State Access)**



**Figure 27-10 Burst ROM Access Timing (One-State Access)**



**Figure 27-11 External Bus Release Timing**



**Figure 27-12 External Bus Request Output Timing**

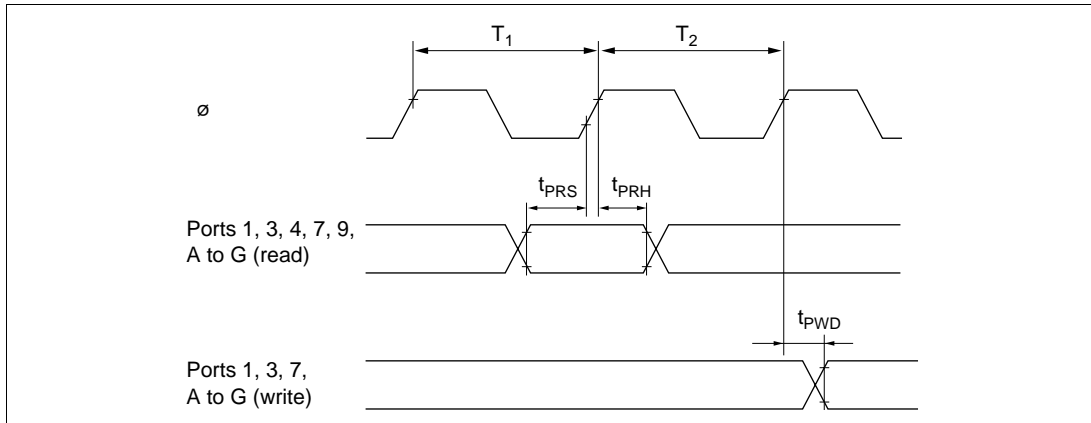
### 27.3.4 Timing of On-Chip Supporting Modules

Table 27-7 lists the timing of on-chip supporting modules.

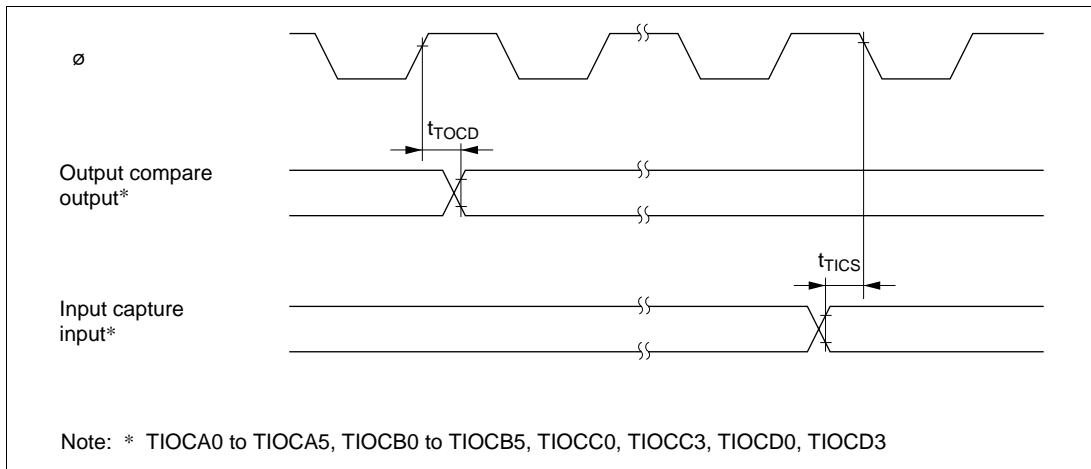
**Table 27-7 Timing of On-Chip Supporting Modules**

Condition:  $PV_{CC} = 4.5\text{ V to }5.5\text{ V}$ ,  $AV_{CC} = 4.5\text{ V to }5.5\text{ V}$ ,  $V_{ref} = 4.5\text{ V to }AV_{CC}$ ,  
 $V_{SS} = AV_{SS} = PLLV_{SS} = 0\text{ V}$ ,  $\phi = 2\text{ to }28\text{ MHz}$ ,  $T_a = -20^\circ\text{C to }+75^\circ\text{C}$  (regular specifications),  $T_a = -40^\circ\text{C to }+85^\circ\text{C}$  (wide-range specifications)

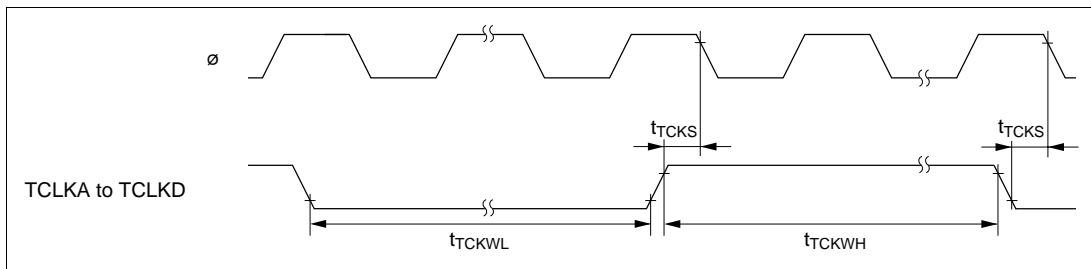
Item		Symbol	Min	Max	Unit	Test Conditions	
I/O port	Output data delay time	$t_{PWD}$	—	40	ns	Figure 27-13	
	Input data setup time	$t_{PRS}$	25	—			
	Input data hold time	$t_{PRH}$	25	—			
TPU	Timer output delay time	$t_{TOCD}$	—	40	ns	Figure 27-14	
	Timer input setup time	$t_{TICS}$	25	—			
	Timer clock input setup time	$t_{TCKS}$	25	—	ns	Figure 27-15	
	Timer clock pulse width	Single edge $t_{TCKWH}$ Both edges $t_{TCKWL}$	1.5 2.5	—	$t_{cyc}$		
WDT0	Overflow output delay time	$t_{WOVD}$	—	40	ns	Figure 27-16	
SCI	Input clock cycle	Asynchronous	$t_{Scyc}$	4	—	$t_{cyc}$	Figure 27-17
		Synchronous		6	—		
	Input clock pulse width	$t_{SCKW}$	0.4	0.6	$t_{Scyc}$		
	Input clock rise time	$t_{SCKr}$	—	1.5	$t_{cyc}$		
	Input clock fall time	$t_{SCKf}$	—	1.5			
	Transmit data delay time	$t_{TXD}$	—	40	ns	Figure 27-18	
	Receive data setup time (synchronous)	$t_{RXS}$	40	—			
	Receive data hold time (synchronous)	$t_{RXH}$	40	—			
A/D converter	Trigger input setup time	$t_{TRGS}$	40	—	ns	Figure 27-19	



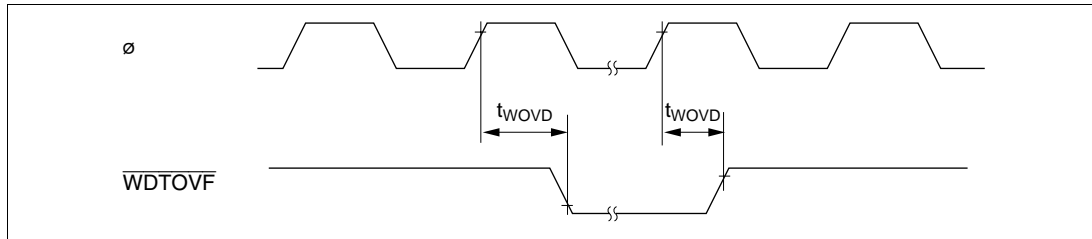
**Figure 27-13 I/O Port Input/Output Timing**



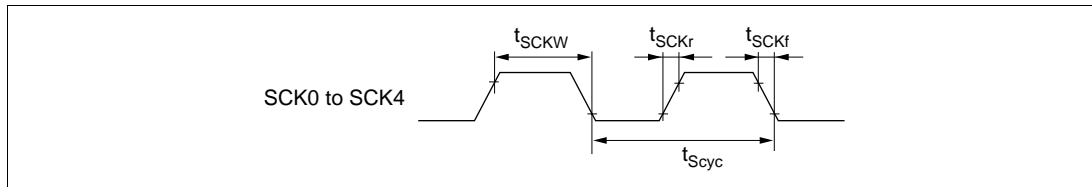
**Figure 27-14 TPU Input/Output Timing**



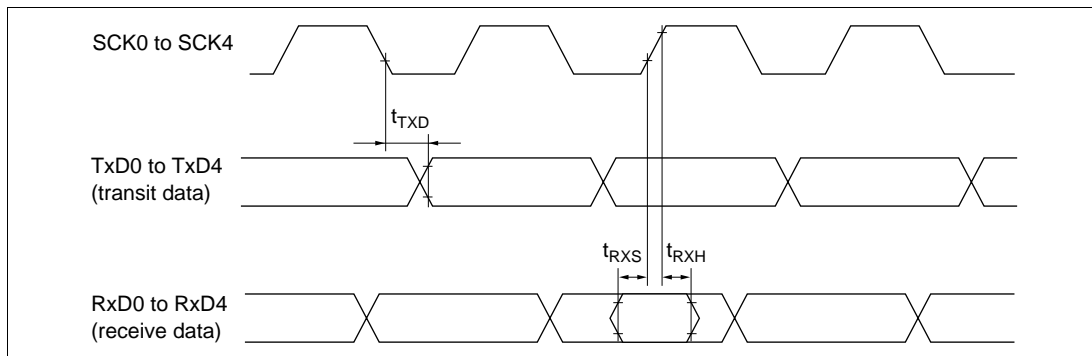
**Figure 27-15 TPU Clock Input Timing**



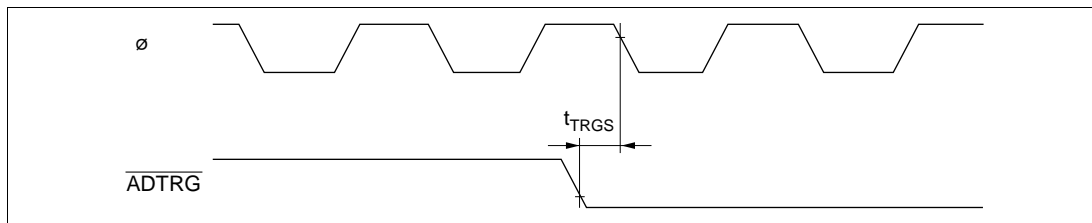
**Figure 27-16 WDT0 Output Timing**



**Figure 27-17 SCK Clock Input Timing**



**Figure 27-18 SCI Input/Output Timing (Clock Synchronous Mode)**



**Figure 27-19 A/D Converter External Trigger Input Timing**

## 27.4 A/D Conversion Characteristics

Table 27-8 lists the A/D conversion characteristics.

**Table 27-8 A/D Conversion Characteristics**

Condition:  $PV_{CC} = 4.5\text{ V to }5.5\text{ V}$ ,  $AV_{CC} = 4.5\text{ V to }5.5\text{ V}$ ,  $V_{ref} = 4.5\text{ V to }AV_{CC}$ ,  
 $V_{SS} = AV_{SS} = PLLV_{SS} = 0\text{ V}$ ,  $\phi = 2\text{ to }28\text{ MHz}$ ,  $T_a = -20^\circ\text{C to }+75^\circ\text{C}$  (regular specifications),  $T_a = -40^\circ\text{C to }+85^\circ\text{C}$  (wide-range specifications)

Item	Min	Typ	Max	Unit
Resolution	10	10	10	bits
Conversion time	10	—	—	$\mu\text{s}$
Analog input capacitance	—	—	20	pF
Permissible signal-source impedance	—	—	5	$\text{k}\Omega$
Nonlinearity error	—	—	$\pm 3.5$	LSB
Offset error	—	—	$\pm 3.5$	LSB
Full-scale error	—	—	$\pm 3.5$	LSB
Quantization	—	$\pm 0.5$	—	LSB
Absolute accuracy	—	—	$\pm 4.0$	LSB

## 27.5 Usage Note

Although both the F-ZTAT and mask ROM versions fully meet the electrical specifications listed in this manual, due to differences in the fabrication process, the on-chip ROM, and the layout patterns, there will be differences in the actual values of the electrical characteristics, the operating margins, the noise margins, and other aspects.

Therefore, if a system is evaluated using the F-ZTAT version, a similar evaluation should also be performed using the mask ROM version.



# Appendix A Instruction Set

## A.1 Instruction List

### Operand Notation

Rd	General register (destination)*
Rs	General register (source)*
Rn	General register*
ERn	General register (32-bit register)
MAC	Multiply-and-accumulate register (32-bit register)
(EAd)	Destination operand
(EAs)	Source operand
EXR	Extended control register
CCR	Condition-code register
N	N (negative) flag in CCR
Z	Z (zero) flag in CCR
V	V (overflow) flag in CCR
C	C (carry) flag in CCR
PC	Program counter
SP	Stack pointer
#IMM	Immediate data
disp	Displacement
+	Add
−	Subtract
×	Multiply
÷	Divide
^	Logical AND
∨	Logical OR
⊕	Logical exclusive OR
→	Transfer from the operand on the left to the operand on the right, or transition from the state on the left to the state on the right
¬	Logical NOT (logical complement)
( ) < >	Contents of operand
:8/:16/:24/:32	8-, 16-, 24-, or 32-bit length

Note: \* General registers include 8-bit registers (R0H to R7H, R0L to R7L), 16-bit registers (R0 to R7, E0 to E7), and 32-bit registers (ER0 to ER7).

## Condition Code Notation

### Symbol

↑	Changes according to the result of instruction
*	Undetermined (no guaranteed value)
0	Always cleared to 0
1	Always set to 1
—	Not affected by execution of the instruction

Table A-1 Instruction Set

(1) Data Transfer Instructions

Mnemonic	Operand Size	Addressing Mode/ Instruction Length (Bytes)							Operation	Condition Code							No. of States*1 Advanced
		#xx	@ERn	@ERn	@ERn	@ERn/ERn+	@aa	@aa		I	H	N	Z	V	C		
																@(d,PC)	
MOV	B	2							#xx:8→Rd8	—	—	↑	↑	0	—	1	
	B	2							Rs8→Rd8	—	—	↑	↑	0	—	1	
	B	2							@ERs→Rd8	—	—	↑	↑	0	—	2	
	B	4							@(d:16,ERs)→Rd8	—	—	↑	↑	0	—	3	
	B	8							@(d:32,ERs)→Rd8	—	—	↑	↑	0	—	5	
	B	2							@ERs→Rd8,ERs32+1→ERs32	—	—	↑	↑	0	—	3	
	B						2		@aa:8→Rd8	—	—	↑	↑	0	—	2	
	B						4		@aa:16→Rd8	—	—	↑	↑	0	—	3	
	B						6		@aa:32→Rd8	—	—	↑	↑	0	—	4	
	B	2							Rs8→@ERd	—	—	↑	↑	0	—	2	
	B	4							Rs8→@(d:16,ERd)	—	—	↑	↑	0	—	3	
	B	8							Rs8→@(d:32,ERd)	—	—	↑	↑	0	—	5	
	B	2							ERd32-1→ERd32,Rs8→@ERd	—	—	↑	↑	0	—	3	
	B						2		Rs8→@aa:8	—	—	↑	↑	0	—	2	
	B						4		Rs8→@aa:16	—	—	↑	↑	0	—	3	
	B						6		Rs8→@aa:32	—	—	↑	↑	0	—	4	
	W	4							#xx:16→Rd16	—	—	↑	↑	0	—	2	
	W	2							Rs16→Rd16	—	—	↑	↑	0	—	1	
	W	2							@ERs→Rd16	—	—	↑	↑	0	—	2	

Mnemonic	Operand Size	Addressing Mode/ Instruction Length (Bytes)							Operation	Condition Code					No. of States*1 Advanced	
		#xx	Rn	@ERN	@(d,ERn)	@-ERn/ERn+	@aa	@(d,PC)		@aa	I	H	N	Z		V
MOV	W		4						@(d:16,ERs)→Rd16	—	—	↑	↓	0	—	3
	W		8						@(d:32,ERs)→Rd16	—	—	↑	↓	0	—	5
	W			2					@ERs→Rd16,ERs32+2→ERs32	—	—	↑	↓	0	—	3
	W				4				@aa:16→Rd16	—	—	↑	↓	0	—	3
	W					6			@aa:32→Rd16	—	—	↑	↓	0	—	4
	W			2					Rs16→@ERd	—	—	↑	↓	0	—	2
	W				4				Rs16→@(d:16,ERd)	—	—	↑	↓	0	—	3
	W					8			Rs16→@(d:32,ERd)	—	—	↑	↓	0	—	5
	W			2					ERd32-2→ERd32,Rs16→@ERd	—	—	↑	↓	0	—	3
	W						4		Rs16→@aa:16	—	—	↑	↓	0	—	3
	W						6		Rs16→@aa:32	—	—	↑	↓	0	—	4
	L	6							#xx:32→ERd32	—	—	↑	↓	0	—	3
	L		2						ERS32→ERd32	—	—	↑	↓	0	—	1
	L			4					@ERs→ERd32	—	—	↑	↓	0	—	4
	L				6				@(d:16,ERs)→ERd32	—	—	↑	↓	0	—	5
	L					10			@(d:32,ERs)→ERd32	—	—	↑	↓	0	—	7
	L			4					@ERs→ERd32,ERs32+4→@ERs32	—	—	↑	↓	0	—	5
	L						6		@aa:16→ERd32	—	—	↑	↓	0	—	5
	L						8		@aa:32→ERd32	—	—	↑	↓	0	—	6

Mnemonic	Operand Size	Addressing Mode/ Instruction Length (Bytes)								Operation	Condition Code					No. of States*1 Advanced	
		#xx	ERn	@(d,ERn)	@-ERn/@ERn+	aa	@(d,PC)	@aa	@aa		I	H	N	Z	V		C
		4	6	10	4	6	8				↕	↕	↕	↕	↕		↕
MOV	L		4							ERs32→@ERd			↕	↕	0	—	4
	L			6						ERs32→@(d:16,ERd)			↕	↕	0	—	5
	L			10						ERs32→@(d:32,ERd)			↕	↕	0	—	7
	L			4						ERd32-4→ERd32,ERs32→@ERd			↕	↕	0	—	5
	L						6			ERs32→@aa:16			↕	↕	0	—	5
	L						8			ERs32→@aa:32			↕	↕	0	—	6
POP	W							2		@SP→Rn16,SP+2→SP			↕	↕	0	—	3
	L							4		@SP→ERn32,SP+4→SP			↕	↕	0	—	5
PUSH	W							2		SP-2→SP,Rn16→@SP			↕	↕	0	—	3
	L							4		SP-4→SP,ERn32→@SP			↕	↕	0	—	5
LDM	L							4		(@SP→ERn32,SP+4→SP)			—	—	—	—	7/9/11 [1]
	L							4		Repeated for each register restored (SP-4→SP,ERn32→@SP)			—	—	—	—	7/9/11 [1]
	L							4		Repeated for each register saved			—	—	—	—	
MOVFP										Cannot be used in the H8S/2633 Series							[2]
MOVTP										Cannot be used in the H8S/2633 Series							[2]

(2) Arithmetic Instructions

Mnemonic	Operand Size	Addressing Mode/ Instruction Length (Bytes)							Operation	Condition Code					No. of States*1	
		#xx	Rn	@ERn	@(d,ERn)	@-ERn/@ERn+	@aa	@(d,PC)		@aa	I	H	N	Z		V
ADD	B 2								Rd8+#xx:8→Rd8	—	↑	↑	↑	↑	↑	1
	B 2								Rd8+Rs8→Rd8	—	↑	↑	↑	↑	↑	1
	W 4								Rd16+#xx:16→Rd16	—	[3]	↑	↑	↑	↑	2
	W 2								Rd16+Rs16→Rd16	—	[3]	↑	↑	↑	↑	1
	L 6								ERd32+#xx:32→ERd32	—	[4]	↑	↑	↑	↑	3
	L 2								ERd32+ERs32→ERd32	—	[4]	↑	↑	↑	↑	1
ADDX	B 2								Rd8+#xx:8+C→Rd8	—	↑	↑	↑	[5]	↑	1
	B 2								Rd8+Rs8+C→Rd8	—	↑	↑	[5]	↑	↑	1
ADDS	L 2								ERd32+1→ERd32	—	—	—	—	—	—	1
	L 2								ERd32+2→ERd32	—	—	—	—	—	—	1
	L 2								ERd32+4→ERd32	—	—	—	—	—	—	1
	B 2								Rd8+1→Rd8	—	—	—	—	↑	↑	1
INC	W 2								Rd16+1→Rd16	—	—	—	—	↑	↑	1
	W 2								Rd16+2→Rd16	—	—	—	—	↑	↑	1
	L 2								ERd32+1→ERd32	—	—	—	—	↑	↑	1
	L 2								ERd32+2→ERd32	—	—	—	—	↑	↑	1
DAA	B 2							Rd8 decimal adjust→Rd8	—	*	↑	↑	↑	*	↑	1
SUB	B 2								Rd8-Rs8→Rd8	—	↑	↑	↑	↑	↑	1
	W 4								Rd16+#xx:16→Rd16	—	[3]	↑	↑	↑	↑	2

Mnemonic	Operand Size	Addressing Mode/ Instruction Length (Bytes)										Operation	Condition Code					No. of States*1 Advanced						
		#xx	FR	@ERn	@(d,ERn)	@-ERn/@ERn+	@aa	@(d,PC)	@aa	@aa			I	H	N	Z	V		C					
SUB	SUB.W Rs,Rd	W	2															[3]	↑	↑	↑	↑	1	
	SUB.L #xx:32,ERd	L	6																[4]	↑	↑	↑	↑	3
	SUB.L ERs,ERd	L	2																[4]	↑	↑	↑	↑	1
SUBX	SUBX #xx:8,Rd	B	2																↑	↑	[5]	↑	↑	1
	SUBX Rs,Rd	B	2																↑	↑	[5]	↑	↑	1
SUBS	SUBS #1,ERd	L	2																—	—	—	—	—	1
	SUBS #2,ERd	L	2																—	—	—	—	—	1
	SUBS #4,ERd	L	2																—	—	—	—	—	1
	DEC.B Rd	B	2																—	—	—	—	—	1
DEC	DEC.W #1,Rd	W	2																—	—	—	—	—	1
	DEC.W #2,Rd	W	2																—	—	—	—	—	1
	DEC.L #1,ERd	L	2																—	—	—	—	—	1
	DEC.L #2,ERd	L	2																—	—	—	—	—	1
	DAS Rd	B	2																*	↑	↑	*	—	1
MULXU	MULXU.B Rs,Rd	B	2																—	—	—	—	—	3
	MULXU.W Rs,ERd	W	2																—	—	—	—	—	4
MULXS	MULXS.B Rs,Rd	B	4																—	—	—	—	—	4
	MULXS.W Rs,ERd	W	4																—	—	—	—	—	5

Mnemonic	Operand Size	Addressing Mode/ Instruction Length (Bytes)						Operation	Condition Code				No. of States*1			
		#xx	@ERn	@(d,ERn)	@-ERn/@ERn+	@aa	@(d,PC)		@aa	I	H	N	Z	V	C	Advanced
DIVXU	B	2						Rd16-Rs8→Rd16 (RdH: remainder, RdL: quotient) (unsigned division)				[6]	[7]			12
	W	2						ERd32-Rs16→ERd32 (Ed: remainder, Rd: quotient) (unsigned division)				[6]	[7]			20
DIVXS	B	4						Rd16-Rs8→Rd16 (RdH: remainder, RdL: quotient) (signed division)				[8]	[7]			13
	W	4						ERd32-Rs16→ERd32 (Ed: remainder, Rd: quotient) (signed division)				[8]	[7]			21
CMP	B	2						Rd8-#xx:8				↑	↑	↑	↑	1
	B	2						Rd8-Rs8				↑	↑	↑	↑	1
	W	4						Rd16-#xx:16				[3]	↑	↑	↑	2
	W	2						Rd16-Rs16				[3]	↑	↑	↑	1
	L	6						ERd32-#xx:32				[4]	↑	↑	↑	3
	L	2						ERd32-ERs32				[4]	↑	↑	↑	1
NEG	B	2						0-Rd8→Rd8				↑	↑	↑	↑	1
	W	2						0-Rd16→Rd16				↑	↑	↑	↑	1
	L	2						0-ERd32→ERd32				↑	↑	↑	↑	1
EXTU	W	2						0→(<bit 15 to 8> of Rd16)					0	↑	0	1
	L	2						0→(<bit 31 to 16> of ERd32)					0	↑	0	1



Mnemonic	Operand Size	Addressing Mode/ Instruction Length (Bytes)							Operation	Condition Code					No. of States*1 Advanced	
		#xx	Rn	@ERn	@(d,ERn)	@-ERn/ERn+	@aa	@(d,PC)		@aa	I	H	N	Z		V
EXTS	W	2							<bit 7> of Rd16)→ <bit 15 to 8> of Rd16)	—	—	↕	↕	0	—	1
	L	2							<bit 15> of ERd32)→ <bit 31 to 16> of ERd32)	—	—	↕	↕	0	—	1
TAS*3	B	4	4						@ERd-0→CCR set, (1)→ <bit 7> of @ERd)	—	—	↕	↕	0	—	4
MAC	—			4					@ERn@ERn+MAC→MAC (signal multiplication) @ERn+2→ERn, ERn+2→ERm	—	—	—	—	—	—	4
CLRMAC	—						2		0→MACH, MACL	—	—	—	—	—	—	2 [12]
LDMAC	L	2							ERs→MACH	—	—	—	—	—	—	2 [12]
	L	2							ERs→MACL	—	—	—	—	—	—	2 [12]
STMAC	L	2							MACH→ERd	—	—	↕	↕	—	—	1 [12]
	L	2							MACL→ERd	—	—	↕	↕	—	—	1 [12]

(3) Logical Instructions

Mnemonic	Operand Size	Addressing Mode/ Instruction Length (Bytes)							Operation	Condition Code							No. of States*1 Advanced
		#xx Rn	@ERn	@(d,ERn)	@-ERn/@ERn+	@aa	@(d,PC)	@aa		I	H	N	Z	V	C		
AND	AND.B #xx:8,Rd	B 2							Rd8 $\wedge$ #xx:8 $\rightarrow$ Rd8	—	—	$\updownarrow$	0	—	1		
	AND.B Rs,Rd	B 2							Rd8 $\wedge$ Rs8 $\rightarrow$ Rd8	—	—	$\updownarrow$	0	—	1		
	AND.W #xx:16,Rd	W 4							Rd16 $\wedge$ #xx:16 $\rightarrow$ Rd16	—	—	$\updownarrow$	0	—	2		
	AND.W Rs,Rd	W 2							Rd16 $\wedge$ Rs16 $\rightarrow$ Rd16	—	—	$\updownarrow$	0	—	1		
	AND.L #xx:32,ERd	L 6							ERd32 $\wedge$ #xx:32 $\rightarrow$ ERd32	—	—	$\updownarrow$	0	—	3		
	AND.L ERs,ERd	L 4							ERd32 $\wedge$ ERs32 $\rightarrow$ ERd32	—	—	$\updownarrow$	0	—	2		
OR	OR.B #xx:8,Rd	B 2							Rd8 $\vee$ #xx:8 $\rightarrow$ Rd8	—	—	$\updownarrow$	0	—	1		
	OR.B Rs,Rd	B 2							Rd8 $\vee$ Rs8 $\rightarrow$ Rd8	—	—	$\updownarrow$	0	—	1		
	OR.W #xx:16,Rd	W 4							Rd16 $\vee$ #xx:16 $\rightarrow$ Rd16	—	—	$\updownarrow$	0	—	2		
	OR.W Rs,Rd	W 2							Rd16 $\vee$ Rs16 $\rightarrow$ Rd16	—	—	$\updownarrow$	0	—	1		
	OR.L #xx:32,ERd	L 6							ERd32 $\vee$ #xx:32 $\rightarrow$ ERd32	—	—	$\updownarrow$	0	—	3		
	OR.L ERs,ERd	L 4							ERd32 $\vee$ ERs32 $\rightarrow$ ERd32	—	—	$\updownarrow$	0	—	2		
XOR	XOR.B #xx:8,Rd	B 2							Rd8 $\oplus$ #xx:8 $\rightarrow$ Rd8	—	—	$\updownarrow$	0	—	1		
	XOR.B Rs,Rd	B 2							Rd8 $\oplus$ Rs8 $\rightarrow$ Rd8	—	—	$\updownarrow$	0	—	1		
	XOR.W #xx:16,Rd	W 4							Rd16 $\oplus$ #xx:16 $\rightarrow$ Rd16	—	—	$\updownarrow$	0	—	2		
	XOR.W Rs,Rd	W 2							Rd16 $\oplus$ Rs16 $\rightarrow$ Rd16	—	—	$\updownarrow$	0	—	1		
	XOR.L #xx:32,ERd	L 6							ERd32 $\oplus$ #xx:32 $\rightarrow$ ERd32	—	—	$\updownarrow$	0	—	3		
	XOR.L ERs,ERd	L 4							ERd32 $\oplus$ ERs32 $\rightarrow$ ERd32	—	—	$\updownarrow$	0	—	2		
NOT	NOT.B Rd	B 2							$\neg$ Rd8 $\rightarrow$ Rd8	—	—	$\updownarrow$	0	—	1		
	NOT.W Rd	W 2							$\neg$ Rd16 $\rightarrow$ Rd16	—	—	$\updownarrow$	0	—	1		
	NOT.L ERd	L 2							$\neg$ ERd32 $\rightarrow$ ERd32	—	—	$\updownarrow$	0	—	1		

(4) Shift Instructions

Mnemonic	Operand Size	Addressing Mode/ Instruction Length (Bytes)							Operation	Condition Code				No. of States*1 Advanced		
		#xx	Rn	@ERn	@(d,ERn)	@-ERn/@ERn+	@aa	@(d,PC)		@aa	I	H	N		Z	V
SHAL	B	2										↕	↕	↕	↕	1
	B	2										↕	↕	↕	↕	1
	W	2										↕	↕	↕	↕	1
	W	2										↕	↕	↕	↕	1
	L	2										↕	↕	↕	↕	1
SHAR	B	2										↕	↕	↕	↕	1
	B	2										↕	↕	↕	↕	1
	W	2										↕	↕	↕	↕	1
	W	2										↕	↕	↕	↕	1
	L	2										↕	↕	↕	↕	1
SHLL	B	2										↕	↕	↕	↕	1
	B	2										↕	↕	↕	↕	1
	W	2										↕	↕	↕	↕	1
	W	2										↕	↕	↕	↕	1
	L	2										↕	↕	↕	↕	1

Mnemonic	Operand Size	Addressing Mode/ Instruction Length (Bytes)						Operation	Condition Code						No. of States*1	
		#xx	Rn	@ERn	@(d,ERn)	@-ERn/@ERn+	@aa		@(d,PC)	@aa		I	H	N		Z
SHLR	B	2							—	—	0	↕	0	↕	1	1
	B	2							—	—	0	↕	0	↕	1	1
	W	2							—	—	0	↕	0	↕	1	1
	W	2							—	—	0	↕	0	↕	1	1
	L	2							—	—	0	↕	0	↕	1	1
	L	2							—	—	0	↕	0	↕	1	1
ROTXL	B	2							—	—	↕	↕	0	↕	1	1
	B	2							—	—	↕	↕	0	↕	1	1
	W	2							—	—	↕	↕	0	↕	1	1
	W	2							—	—	↕	↕	0	↕	1	1
	L	2							—	—	↕	↕	0	↕	1	1
	L	2							—	—	↕	↕	0	↕	1	1
ROTXR	B	2							—	—	↕	↕	0	↕	1	1
	B	2							—	—	↕	↕	0	↕	1	1
	W	2							—	—	↕	↕	0	↕	1	1
	W	2							—	—	↕	↕	0	↕	1	1
	L	2							—	—	↕	↕	0	↕	1	1
	L	2							—	—	↕	↕	0	↕	1	1

Mnemonic	Operand Size	Addressing Mode/ Instruction Length (Bytes)							Operation	Condition Code							No. of States*1 Advanced
		#xx	Rn	@ERn	@(d,ERn)	@-ERn/@ERn+	@aa	@(d,PC)		@aa	I	H	N	Z	V	C	
ROTL	B	2								↔	↔	↔	↔	↔	↔	1	
	B	2								↔	↔	↔	↔	↔	↔	1	
	W	2								↔	↔	↔	↔	↔	↔	1	
	W	2								↔	↔	↔	↔	↔	↔	1	
	L	2								↔	↔	↔	↔	↔	↔	1	
	L	2								↔	↔	↔	↔	↔	↔	1	
ROTR	B	2							↔	↔	↔	↔	↔	↔	1		
	B	2							↔	↔	↔	↔	↔	↔	1		
	W	2							↔	↔	↔	↔	↔	↔	1		
	W	2							↔	↔	↔	↔	↔	↔	1		
	L	2							↔	↔	↔	↔	↔	↔	1		
	L	2							↔	↔	↔	↔	↔	↔	1		

(5) Bit-Manipulation Instructions

Mnemonic	Operand Size	Addressing Mode/ Instruction Length (Bytes)						Operation	Condition Code					No. of States*1 Advanced	
		#xx	Rn	@ERn	(d,ERn)	@ERn/ERn+	aa		@(d,PC)	@aa	I	H	N		Z
BSET	B	2						(#xx:3 of Rd8)←1	—	—	—	—	—	—	1
	B	4						(#xx:3 of @ERd)←1	—	—	—	—	—	—	4
	B		4					(#xx:3 of @aa:8)←1	—	—	—	—	—	—	4
	B			6				(#xx:3 of @aa:16)←1	—	—	—	—	—	—	5
	B				8			(#xx:3 of @aa:32)←1	—	—	—	—	—	—	6
BSET Rn,Rd	B	2						(Rn8 of Rd8)←1	—	—	—	—	—	—	1
	B	4						(Rn8 of @ERd)←1	—	—	—	—	—	—	4
	B		4					(Rn8 of @aa:8)←1	—	—	—	—	—	—	4
	B			6				(Rn8 of @aa:16)←1	—	—	—	—	—	—	5
	B				8			(Rn8 of @aa:32)←1	—	—	—	—	—	—	6
BCLR	B	2						(#xx:3 of Rd8)←0	—	—	—	—	—	—	1
	B	4						(#xx:3 of @ERd)←0	—	—	—	—	—	—	4
	B		4					(#xx:3 of @aa:8)←0	—	—	—	—	—	—	4
	B			6				(#xx:3 of @aa:16)←0	—	—	—	—	—	—	5
	B				8			(#xx:3 of @aa:32)←0	—	—	—	—	—	—	6
BCLR Rn,Rd	B	2						(Rn8 of Rd8)←0	—	—	—	—	—	—	1
	B	4						(Rn8 of @ERd)←0	—	—	—	—	—	—	4
	B		4					(Rn8 of @aa:8)←0	—	—	—	—	—	—	4
	B			6				(Rn8 of @aa:16)←0	—	—	—	—	—	—	5
	B				8			(Rn8 of @aa:32)←0	—	—	—	—	—	—	6

Mnemonic	Operand Size	Addressing Mode/ Instruction Length (Bytes)								Operation	Condition Code				No. of States*1 Advanced	
		#xx	Rn	(d,ERn)	(d,ERn) +ERn	aa	(d,PC) @aa	@	@		I	H	N	Z		V
BCLR	B					8				(Rn8 of @aa:32)←0	—	—	—	—	—	6
BNOT	B	2								(#xx:3 of Rd8)←[¬ (#xx:3 of Rd8)]	—	—	—	—	—	1
	B		4							(#xx:3 of @ERd)← [¬ (#xx:3 of @ERd)]	—	—	—	—	—	4
	B					4				(#xx:3 of @aa:8)← [¬ (#xx:3 of @aa:8)]	—	—	—	—	—	4
	B					6				(#xx:3 of @aa:16)← [¬ (#xx:3 of @aa:16)]	—	—	—	—	—	5
BNOT	B					8				(#xx:3 of @aa:32)← [¬ (#xx:3 of @aa:32)]	—	—	—	—	—	6
	B	2								(Rn8 of Rd8)←[¬ (Rn8 of Rd8)]	—	—	—	—	—	1
	B		4							(Rn8 of @ERd)←[¬ (Rn8 of @ERd)]	—	—	—	—	—	4
	B					4				(Rn8 of @aa:8)←[¬ (Rn8 of @aa:8)]	—	—	—	—	—	4
BNOT	B					6				(Rn8 of @aa:16)← [¬ (Rn8 of @aa:16)]	—	—	—	—	—	5
	B					8				(Rn8 of @aa:32)← [¬ (Rn8 of @aa:32)]	—	—	—	—	—	6
	B									(Rn8 of @aa:32)← [¬ (Rn8 of @aa:32)]	—	—	—	—	—	6
	B									(Rn8 of @aa:32)← [¬ (Rn8 of @aa:32)]	—	—	—	—	—	6
BTST	B	2								¬ (#xx:3 of Rd8)→Z	—	—	—	↕	—	1
	B		4							¬ (#xx:3 of @ERd)→Z	—	—	—	↕	—	3
	B					4				¬ (#xx:3 of @aa:8)→Z	—	—	—	↕	—	3
	B					6				¬ (#xx:3 of @aa:16)→Z	—	—	—	↕	—	4

Mnemonic	Operand Size	Addressing Mode/ Instruction Length (Bytes)							Operation	Condition Code					No. of States*1 Advanced	
		#xx	Rn	@ERn	@(d,ERn)	@-ERn/@ERn+	@aa	@(d,PC)		@aa	I	H	N	Z		V
BTST	B					8			¬ (#xx:3 of @aa:32) → Z	—	—	—	—	—	—	5
	B	2							¬ (Rn8 of Rd8) → Z	—	—	—	—	—	—	1
	B	4							¬ (Rn8 of @ERd) → Z	—	—	—	—	—	—	3
	B		4						¬ (Rn8 of @aa:8) → Z	—	—	—	—	—	—	3
	B			6					¬ (Rn8 of @aa:16) → Z	—	—	—	—	—	—	4
	B				8				¬ (Rn8 of @aa:32) → Z	—	—	—	—	—	—	5
BLD	B	2							(#xx:3 of Rd8) → C	—	—	—	—	—	—	1
	B	4							(#xx:3 of @ERd) → C	—	—	—	—	—	—	3
	B		4						(#xx:3 of @aa:8) → C	—	—	—	—	—	—	3
	B			6					(#xx:3 of @aa:16) → C	—	—	—	—	—	—	4
	B				8				(#xx:3 of @aa:32) → C	—	—	—	—	—	—	5
	B	2							¬ (#xx:3 of Rd8) → C	—	—	—	—	—	—	1
BILD	B	4							¬ (#xx:3 of @ERd) → C	—	—	—	—	—	—	3
	B		4						¬ (#xx:3 of @aa:8) → C	—	—	—	—	—	—	3
	B			6					¬ (#xx:3 of @aa:16) → C	—	—	—	—	—	—	4
	B				8				¬ (#xx:3 of @aa:32) → C	—	—	—	—	—	—	5
	B	2							C → (#xx:3 of Rd8)	—	—	—	—	—	—	1
	B	4							C → (#xx:3 of @ERd)	—	—	—	—	—	—	4
BST	B					4			C → (#xx:3 of @aa:8)	—	—	—	—	—	—	4



Mnemonic	Operand Size	Addressing Mode/ Instruction Length (Bytes)							Operation	Condition Code					No. of States*1 Advanced		
		#xx	F <sub>1</sub>	@ERn	@(d,ERn)	@-ERn/@ERn+	aa	@(d,PC)		@aa	I	H	N	Z		V	C
BST	B						6		C→(#xx:3 of @aa:16)	—	—	—	—	—	5		
	B						8		C→(#xx:3 of @aa:32)	—	—	—	—	—	6		
BIST	B	2							¬ C→(#xx:3 of Rd8)	—	—	—	—	—	1		
	B	4							¬ C→(#xx:3 of @ERd)	—	—	—	—	—	4		
	B		4						¬ C→(#xx:3 of @aa:8)	—	—	—	—	—	4		
	B		6						¬ C→(#xx:3 of @aa:16)	—	—	—	—	—	5		
BAND	B		8						¬ C→(#xx:3 of @aa:32)	—	—	—	—	—	6		
	B	2							C^(#xx:3 of Rd8)→C	—	—	—	—	↑	1		
	B	4							C^(#xx:3 of @ERd)→C	—	—	—	—	↑	3		
	B		4						C^(#xx:3 of @aa:8)→C	—	—	—	—	↑	3		
	B		6						C^(#xx:3 of @aa:16)→C	—	—	—	—	↑	4		
	B		8						C^(#xx:3 of @aa:32)→C	—	—	—	—	↑	5		
BIAND	B	2							C^[¬ (#xx:3 of Rd8)]→C	—	—	—	—	↓	1		
	B	4							C^[¬ (#xx:3 of @ERd)]→C	—	—	—	—	↓	3		
	B		4						C^[¬ (#xx:3 of @aa:8)]→C	—	—	—	—	↓	3		
	B		6						C^[¬ (#xx:3 of @aa:16)]→C	—	—	—	—	↓	4		
	B		8						C^[¬ (#xx:3 of @aa:32)]→C	—	—	—	—	↓	5		
	BOR	B	2							Cv(#xx:3 of Rd8)→C	—	—	—	—	↓	1	
B		4							Cv(#xx:3 of @ERd)→C	—	—	—	—	↓	3		

Mnemonic	Operand Size	Addressing Mode/ Instruction Length (Bytes)							Operation	Condition Code					No. of States*1	
		#xx	Rn	@ERn	@(d,ERn)	@-ERn/@ERn+	@aa	@(d,PC)		@aa	I	H	N	Z		V
BOR	B						4		Cv(#xx:3 of @aa:8)→C	—	—	—	—	—	↑	3
	B						6		Cv(#xx:3 of @aa:16)→C	—	—	—	—	—	↑	4
	B						8		Cv(#xx:3 of @aa:32)→C	—	—	—	—	—	↑	5
BIOR	B	2							Cv[- (#xx:3 of Rd8)]→C	—	—	—	—	—	↑	1
	B	4							Cv[- (#xx:3 of @ERd)]→C	—	—	—	—	—	↑	3
	B						4		Cv[- (#xx:3 of @aa:8)]→C	—	—	—	—	—	↑	3
	B						6		Cv[- (#xx:3 of @aa:16)]→C	—	—	—	—	—	↑	4
	B						8		Cv[- (#xx:3 of @aa:32)]→C	—	—	—	—	—	↑	5
BXOR	B	2							C⊕(#xx:3 of Rd8)→C	—	—	—	—	—	↑	1
	B	4							C⊕(#xx:3 of @ERd)→C	—	—	—	—	—	↑	3
	B						4		C⊕(#xx:3 of @aa:8)→C	—	—	—	—	—	↑	3
	B						6		C⊕(#xx:3 of @aa:16)→C	—	—	—	—	—	↑	4
	B						8		C⊕(#xx:3 of @aa:32)→C	—	—	—	—	—	↑	5
BIXOR	B	2							C⊕[- (#xx:3 of Rd8)]→C	—	—	—	—	—	↑	1
	B	4							C⊕[- (#xx:3 of @ERd)]→C	—	—	—	—	—	↑	3
	B						4		C⊕[- (#xx:3 of @aa:8)]→C	—	—	—	—	—	↑	3
	B						6		C⊕[- (#xx:3 of @aa:16)]→C	—	—	—	—	—	↑	4
	B						8		C⊕[- (#xx:3 of @aa:32)]→C	—	—	—	—	—	↑	5

### (6) Branch Instructions

Mnemonic	Operand Size	Addressing Mode/ Instruction Length (Bytes)										Operation	Branching Condition	Condition Code					No. of States*1								
		#xx	FR	@ERn	@(d,ERn)	@-ERn/@ERn+	@aa	@(d,PC)	@aa	@	I			H	N	Z	V	C		Advanced							
Bcc	—											2						Always	—	—	—	—	—	—	2		
BRA d:8(BT d:8)	—											4							—	—	—	—	—	—	—	3	
BRA d:16(BT d:16)	—											2						Never	—	—	—	—	—	—	—	2	
BRN d:8(BF d:8)	—											4							—	—	—	—	—	—	—	3	
BRN d:16(BF d:16)	—											2						C <sub>v</sub> Z=0	—	—	—	—	—	—	—	2	
BHI d:8	—											4							—	—	—	—	—	—	—	3	
BHI d:16	—											2							—	—	—	—	—	—	—	2	
BLS d:8	—											4							—	—	—	—	—	—	—	3	
BLS d:16	—											2							—	—	—	—	—	—	—	2	
BCC d:8(BHS d:8)	—											4							—	—	—	—	—	—	—	3	
BCC d:16(BHS d:16)	—											2							—	—	—	—	—	—	—	2	
BCS d:8(BLO d:8)	—											4							—	—	—	—	—	—	—	3	
BCS d:16(BLO d:16)	—											2							—	—	—	—	—	—	—	2	
BNE d:8	—											4							Z=0	—	—	—	—	—	—	—	3
BNE d:16	—											2								—	—	—	—	—	—	2	
BEQ d:8	—											4							Z=1	—	—	—	—	—	—	—	3
BEQ d:16	—											2								—	—	—	—	—	—	2	
BVC d:8	—											4							V=0	—	—	—	—	—	—	—	3
BVC d:16	—											2								—	—	—	—	—	—	—	2
	—											4								—	—	—	—	—	—	—	3

Mnemonic	Operand Size	Addressing Mode/ Instruction Length (Bytes)							Operation	Condition Code				No. of States*1		
		#xx	Rn	@ERn	@(d,ERn)	@-ERn/@ERn+	@aa	@(d,PC)		@aa	I	H	N		Z	V
Bcc	—							2		if condition is true then PC←PC+d else next;	V=1	—	—	—	—	2
BVS d:8	—							4			N=0	—	—	—	—	3
BVS d:16	—							2			N=1	—	—	—	—	2
BPL d:8	—							4			N⊕V=0	—	—	—	—	3
BPL d:16	—							2			N⊕V=1	—	—	—	—	2
BMI d:8	—							4			Z∨(N⊕V)=0	—	—	—	—	3
BMI d:16	—							2			Z∨(N⊕V)=1	—	—	—	—	2
BGE d:8	—							4				—	—	—	—	3
BGE d:16	—							2				—	—	—	—	2
BLT d:8	—							4				—	—	—	—	3
BLT d:16	—							2				—	—	—	—	2
BGT d:8	—							4				—	—	—	—	3
BGT d:16	—							2				—	—	—	—	2
BLE d:8	—							4				—	—	—	—	3
BLE d:16	—							2				—	—	—	—	2
BLE d:16	—							4				—	—	—	—	3

Mnemonic	Operand Size	Addressing Mode/ Instruction Length (Bytes)							Operation	Condition Code					No. of States*1 Advanced
		#xx	Rn	@ERn	@(d,ERn)	@-ERn/@ERn+	@aa	@(d,PC) @aa		I	H	N	Z	V	
JMP	—		2						PC←ERn	—	—	—	—	—	2
	—			4					PC←aa:24	—	—	—	—	—	3
	—				2				PC←@aa:8	—	—	—	—	—	5
BSR	—				2				PC→@-SP,PC←PC+d:8	—	—	—	—	—	4
	—				4				PC→@-SP,PC←PC+d:16	—	—	—	—	—	5
JSR	—		2						PC→@-SP,PC←ERn	—	—	—	—	—	4
	—			4					PC→@-SP,PC←aa:24	—	—	—	—	—	5
	—				2				PC→@-SP,PC←@aa:8	—	—	—	—	—	6
RTS	—							2	PC←@SP+	—	—	—	—	—	5

(7) System Control Instructions

Mnemonic	Operand Size	Addressing Mode/ Instruction Length (Bytes)								Operation	Condition Code					No. of States*1	
		#xx	Rn	@ERN	@(d,ERn)	@ERN/@ERN+	@aa	@(d,PC)	@aa		I	H	N	Z	V		C
TRAPA											PC→@-SP,CCR→@-SP, EXR→@-SP,<vector>→PC	1	—	—	—	—	8 [9]
RTE											EXR←@SP+,CCR←@SP+, PC←@SP+	↕	↕	↕	↕	↕	5 [9]
SLEEP											Transition to power-down state	—	—	—	—	—	2
LDC	LDC #xx:8,CCR	B	2								#xx:8→CCR	↕	↕	↕	↕	↕	1
	LDC #xx:8,EXR	B	4								#xx:8→EXR	—	—	—	—	—	2
	LDC Rs,CCR	B	2								Rs8→CCR	↕	↕	↕	↕	↕	1
	LDC Rs,EXR	B	2								Rs8→EXR	—	—	—	—	—	1
	LDC @ERs,CCR	W	4								@ERs→CCR	↕	↕	↕	↕	↕	3
	LDC @ERs,EXR	W	4								@ERs→EXR	—	—	—	—	—	3
	LDC @(d:16,ERs),CCR	W		6							@(d:16,ERs)→CCR	↕	↕	↕	↕	↕	4
	LDC @(d:16,ERs),EXR	W		6							@(d:16,ERs)→EXR	—	—	—	—	—	4
	LDC @(d:32,ERs),CCR	W		10							@(d:32,ERs)→CCR	↕	↕	↕	↕	↕	6
	LDC @(d:32,ERs),EXR	W		10							@(d:32,ERs)→EXR	—	—	—	—	—	6
LDC @ERs+,CCR	W		4							@ERs→CCR,ERS32+2→ERS32	↕	↕	↕	↕	↕	4	
LDC @ERs+,EXR	W		4							@ERs→EXR,ERS32+2→ERS32	—	—	—	—	—	4	
LDC @aa:16,CCR	W		6							@aa:16→CCR	↕	↕	↕	↕	↕	4	
LDC @aa:16,EXR	W		6							@aa:16→EXR	—	—	—	—	—	4	
LDC @aa:32,CCR	W		8							@aa:32→CCR	↕	↕	↕	↕	↕	5	
LDC @aa:32,EXR	W		8							@aa:32→EXR	—	—	—	—	—	5	

Mnemonic	Operand Size	Addressing Mode/ Instruction Length (Bytes)								Operation	Condition Code					No. of States*1 Advanced		
		#xx	FR	@ERN	@(d,ERn)	@-ERn/@ERn+	aa	@(d,PC)	@aa		I	H	N	Z	V		C	
STC	B	2									CCR→Rd8	—	—	—	—	—	1	
	B	2									EXR→Rd8	—	—	—	—	—	1	
	W		4								CCR→@ERd	—	—	—	—	—	3	
	W		4								EXR→@ERd	—	—	—	—	—	3	
	W			6							CCR→@(d:16,ERd)	—	—	—	—	—	4	
	W			6							EXR→@(d:16,ERd)	—	—	—	—	—	4	
	W			10							CCR→@(d:32,ERd)	—	—	—	—	—	6	
	W			10							EXR→@(d:32,ERd)	—	—	—	—	—	6	
	W				4						ERd32-2→ERd32,CCR→@ERd	—	—	—	—	—	4	
	W				4						ERd32-2→ERd32,EXR→@ERd	—	—	—	—	—	4	
	W					6					CCR→@aa:16	—	—	—	—	—	4	
	W					6					EXR→@aa:16	—	—	—	—	—	4	
ANDC	W			8							CCR→@aa:32	—	—	—	—	—	5	
	W			8							EXR→@aa:32	—	—	—	—	—	5	
	B	2									CCR^#xx:8→CCR	↑	↑	↑	↑	1		
	B	4									EXR^#xx:8→EXR	—	—	—	—	—	2	
	B	2									CCRv#xx:8→CCR	↑	↑	↑	↑	1		
	B	4									EXRv#xx:8→EXR	—	—	—	—	—	2	
	B	2									CCR@#xx:8→CCR	↑	↑	↑	↑	1		
	B	4									EXR@#xx:8→EXR	—	—	—	—	—	2	
	NOP	—								2		PC←PC+2	—	—	—	—	—	1

## (8) Block Transfer Instructions

Mnemonic	Operand Size	Addressing Mode/ Instruction Length (Bytes)								Operation	Condition Code				No. of States*1 Advanced	
		#xx	Rn	@ERn	@(d,ERn)	@-ERn/@ERn+	@aa	@(d,PC)	@aa		@	I	H	N		Z
EEPMOV.B	—									4	if R4L≠0 Repeat @ER5→@ER6 ER5+1→ER5 ER6+1→ER6 R4L-1→R4L Until R4L=0 else next;	—	—	—	—	4+2n *2
EEPMOV.W	—									4	if R4≠0 Repeat @ER5→@ER6 ER5+1→ER5 ER6+1→ER6 R4-1→R4 Until R4=0 else next;	—	—	—	—	4+2n *2

Notes: \*1 The number of states is the number of states required for execution when the instruction and its operands are located in on-chip memory.

\*2 n is the initial value of R4L or R4.

\*3 When using the TAS instruction, use register ER0, ER1, ER4, or ER5.

[1] Seven states for saving or restoring two registers, nine states for three registers, or eleven states for four registers.

[2] Cannot be used in the H8S/2633 Series.

[3] Set to 1 when a carry or borrow occurs at bit 11; otherwise cleared to 0.

[4] Set to 1 when a carry or borrow occurs at bit 27; otherwise cleared to 0.

[5] Retains its previous value when the result is zero; otherwise cleared to 0.

[6] Set to 1 when the divisor is negative; otherwise cleared to 0.

[7] Set to 1 when the divisor is zero; otherwise cleared to 0.

[8] Set to 1 when the quotient is negative; otherwise cleared to 0.

[9] One additional state is required for execution when EXR is valid.



## A.2 Instruction Codes

Table A-2 shows the instruction codes.

**Table A-2 Instruction Codes**

Instruc- tion	Mnemonic	Size	Instruction Format																
			1st byte	2nd byte	3rd byte	4th byte	5th byte	6th byte	7th byte	8th byte	9th byte	10th byte							
ADD	ADD.B #xx:8,Rd	B	8	rd	IMM														
	ADD.B Rs,Rd	B	0	8	rs	rd													
	ADD.W #xx:16,Rd	W	7	9	1	rd	IMM												
	ADD.W Rs,Rd	W	0	9	rs	rd													
	ADD.L #xx:32,ERd	L	7	A	1	0:erd	IMM												
	ADD.L ERs,ERd	L	0	A	1	ers:0:erd													
ADDS	ADDS #1,ERd	L	0	B	0	0:erd													
	ADDS #2,ERd	L	0	B	8	0:erd													
	ADDS #4,ERd	L	0	B	9	0:erd													
	ADDS #xx:8,Rd	B	9	rd	IMM														
ADDX	ADDX Rs,Rd	B	0	E	rs	rd													
	ADDX #xx:8,Rd	B	E	rd	IMM														
AND	AND.B Rs,Rd	B	1	6	rs	rd													
	AND.W #xx:16,Rd	W	7	9	6	rd	IMM												
	AND.W Rs,Rd	W	6	6	rs	rd													
	AND.L #xx:32,ERd	L	7	A	6	0:erd	IMM												
	AND.L ERs,ERd	L	0	1	F	0	6	0:ers:0:erd											
	ANDC #xx:8,CCR	B	0	6	IMM														
ANDC	ANDC #xx:8,EXR	B	0	1	4	1	0	6	IMM										
	ANDC #xx:3,Rd	B	7	6	0:IMM	rd													
BAND	BAND #xx:3,@ERd	B	7	C	0:erd	0	7	6	0:IMM	0									
	BAND #xx:3,@aa:8	B	7	E	abs	0	7	6	0:IMM	0									
	BAND #xx:3,@aa:16	B	6	A	1	0	abs	7	6	0:IMM	0								
	BAND #xx:3,@aa:32	B	6	A	3	0	abs	7	6	0:IMM	0								
	BRA d:8 (BT d:8)	—	4	0	disp														
	BRA d:16 (BT d:16)	—	5	8	0	0	disp												
BRN	BRN d:8 (BF d:8)	—	4	1	disp														
	BRN d:16 (BF d:16)	—	5	8	1	0	disp												

Instruc- tion	Mnemonic	Size	Instruction Format																	
			1st byte	2nd byte	3rd byte	4th byte	5th byte	6th byte	7th byte	8th byte	9th byte	10th byte								
Bcc	BHI d:8	—	4	2	disp															
	BHI d:16	—	5	8	2	0	disp													
	BLS d:8	—	4	3	disp															
	BLS d:16	—	5	8	3	0	disp													
	BCC d:8 (BHS d:8)	—	4	4	disp															
	BCC d:16 (BHS d:16)	—	5	8	4	0	disp													
	BCS d:8 (BLO d:8)	—	4	5	disp															
	BCS d:16 (BLO d:16)	—	5	8	5	0	disp													
	BNE d:8	—	4	6	disp															
	BNE d:16	—	5	8	6	0	disp													
	BEQ d:8	—	4	7	disp															
	BEQ d:16	—	5	8	7	0	disp													
	BVC d:8	—	4	8	disp															
	BVC d:16	—	5	8	8	0	disp													
	BVS d:8	—	4	9	disp															
	BVS d:16	—	5	8	9	0	disp													
	BPL d:8	—	4	A	disp															
	BPL d:16	—	5	8	A	0	disp													
	BMI d:8	—	4	B	disp															
	BMI d:16	—	5	8	B	0	disp													
BGE d:8	—	4	C	disp																
BGE d:16	—	5	8	C	0	disp														
BLT d:8	—	4	D	disp																
BLT d:16	—	5	8	D	0	disp														
BGT d:8	—	4	E	disp																
BGT d:16	—	5	8	E	0	disp														
BLE d:8	—	4	F	disp																
BLE d:16	—	5	8	F	0	disp														

Instruction	Mnemonic	Size	Instruction Format																		
			1st byte	2nd byte	3rd byte	4th byte	5th byte	6th byte	7th byte	8th byte	9th byte	10th byte									
BCLR	BCLR #xx:3,Rd	B	7	2	0:IMM	rd															
	BCLR #xx:3,@ERd	B	7	D	0:erd	0	7	2	0:IMM	0											
	BCLR #xx:3,@aa:8	B	7	F	abs		7	2	0:IMM	0											
	BCLR #xx:3,@aa:16	B	6	A	1	8				7	2	0:IMM	0								
	BCLR #xx:3,@aa:32	B	6	A	3	8			abs					7	2	0:IMM	0				
	BCLR Rn,Rd	B	6	2	rn	rd															
	BCLR Rn,@ERd	B	7	D	0:erd	0	6	2	rn	0											
	BCLR Rn,@aa:8	B	7	F	abs		6	2	rn	0											
BIAND	BCLR Rn,@aa:16	B	6	A	1	8			abs		6	2	rn	0							
	BCLR Rn,@aa:32	B	6	A	3	8			abs					6	2	rn	0				
	BIAND #xx:3,Rd	B	7	6	1:IMM	rd															
	BIAND #xx:3,@ERd	B	7	C	0:erd	0	7	6	1:IMM	0											
	BIAND #xx:3,@aa:8	B	7	E	abs		7	6	1:IMM	0											
	BIAND #xx:3,@aa:16	B	6	A	1	0			abs		7	6	1:IMM	0							
	BIAND #xx:3,@aa:32	B	6	A	3	0			abs					7	6	1:IMM	0				
	BILD #xx:3,Rd	B	7	7	1:IMM	rd															
BILD	BILD #xx:3,@ERd	B	7	C	0:erd	0	7	7	1:IMM	0											
	BILD #xx:3,@aa:8	B	7	E	abs		7	7	1:IMM	0											
	BILD #xx:3,@aa:16	B	6	A	1	0			abs		7	7	1:IMM	0							
	BILD #xx:3,@aa:32	B	6	A	3	0			abs					7	7	1:IMM	0				
BIOR	BIOR #xx:3,Rd	B	7	4	1:IMM	rd															
	BIOR #xx:3,@ERd	B	7	C	0:erd	0	7	4	1:IMM	0											
	BIOR #xx:3,@aa:8	B	7	E	abs		7	4	1:IMM	0											
	BIOR #xx:3,@aa:16	B	6	A	1	0			abs		7	4	1:IMM	0							
	BIOR #xx:3,@aa:32	B	6	A	3	0			abs					7	4	1:IMM	0				

Instruction	Mnemonic	Size	Instruction Format																		
			1st byte	2nd byte	3rd byte	4th byte	5th byte	6th byte	7th byte	8th byte	9th byte	10th byte									
BIST	BIST #xx:3,Rd	B	6	7	1:IMM	rd															
	BIST #xx:3,@ERd	B	7	D	0:erd	0	6	7	1:IMM	0											
	BIST #xx:3,@aa:8	B	7	F	abs		6	7	1:IMM	0											
	BIST #xx:3,@aa:16	B	6	A	1	8			abs		6	7	1:IMM	0							
	BIST #xx:3,@aa:32	B	6	A	3	8				abs					6	7	1:IMM	0			
	BIXOR	BIXOR #xx:3,Rd	B	7	5	1:IMM	rd														
	BIXOR #xx:3,@ERd	B	7	C	0:erd	0	7	5	1:IMM	0											
	BIXOR #xx:3,@aa:8	B	7	E	abs		7	5	1:IMM	0											
	BIXOR #xx:3,@aa:16	B	6	A	1	0			abs		7	5	1:IMM	0							
	BIXOR #xx:3,@aa:32	B	6	A	3	0				abs				7	5	1:IMM	0				
BLD	BLD #xx:3,Rd	B	7	7	0:IMM	rd															
	BLD #xx:3,@ERd	B	7	C	0:erd	0	7	7	0:IMM	0											
	BLD #xx:3,@aa:8	B	7	E	abs		7	7	0:IMM	0											
	BLD #xx:3,@aa:16	B	6	A	1	0			abs		7	7	0:IMM	0							
	BLD #xx:3,@aa:32	B	6	A	3	0				abs					7	7	0:IMM	0			
		BNOT #xx:3,Rd	B	7	1	0:IMM	rd														
BNOT	BNOT #xx:3,@ERd	B	7	D	0:erd	0	7	1	0:IMM	0											
	BNOT #xx:3,@aa:8	B	7	F	abs		7	1	0:IMM	0											
	BNOT #xx:3,@aa:16	B	6	A	1	8			abs		7	1	0:IMM	0							
	BNOT #xx:3,@aa:32	B	6	A	3	8				abs					7	1	0:IMM	0			
	BNOT Rn,Rd	B	6	1	rn	rd															
	BNOT Rn,@ERd	B	7	D	0:erd	0	6	1	rn	0											
	BNOT Rn,@aa:8	B	7	F	abs		6	1	rn	0											
	BNOT Rn,@aa:16	B	6	A	1	8			abs		6	1	rn	0							
	BNOT Rn,@aa:32	B	6	A	3	8				abs					6	1	rn	0			
			B	6	A	3	8														

Instruc- tion	Mnemonic	Size	Instruction Format																	
			1st byte	2nd byte	3rd byte	4th byte	5th byte	6th byte	7th byte	8th byte	9th byte	10th byte								
BOR	BOR #xx:3,Rd	B	7	4	0:IMM	rd														
	BOR #xx:3,@ERd	B	7	C	0:erd	0	7	4	0:IMM	0										
	BOR #xx:3,@aa:8	B	7	E	abs		7	4	0:IMM	0										
	BOR #xx:3,@aa:16	B	6	A	1	0	abs	7	4	0:IMM	0									
	BOR #xx:3,@aa:32	B	6	A	3	0	abs					7	4	0:IMM	0					
	BSET #xx:3,Rd	B	7	0	0:IMM	rd														
BSET	BSET #xx:3,@ERd	B	7	D	0:erd	0	7	0	0:IMM	0										
	BSET #xx:3,@aa:8	B	7	F	abs		7	0	0:IMM	0										
	BSET #xx:3,@aa:16	B	6	A	1	8	abs	7	0	0:IMM	0									
	BSET #xx:3,@aa:32	B	6	A	3	8	abs					7	0	0:IMM	0					
	BSET Rn,Rd	B	6	0	rn	rd														
	BSET Rn,@ERd	B	7	D	0:erd	0	6	0	rn	0										
BST	BST Rn,@aa:8	B	7	F	abs		6	0	rn	0										
	BST Rn,@aa:16	B	6	A	1	8	abs	6	0	rn	0									
	BST Rn,@aa:32	B	6	A	3	8	abs					6	0	rn	0					
	BSR d:8	—	5	5	disp															
	BSR d:16	—	5	C	0	0	disp													
	BST #xx:3,Rd	B	6	7	0:IMM	rd														
BTST	BST #xx:3,@ERd	B	7	D	0:erd	0	6	7	0:IMM	0										
	BST #xx:3,@aa:8	B	7	F	abs		6	7	0:IMM	0										
	BST #xx:3,@aa:16	B	6	A	1	8	abs	6	7	0:IMM	0									
	BST #xx:3,@aa:32	B	6	A	3	8	abs					6	7	0:IMM	0					
	BTST #xx:3,Rd	B	7	3	0:IMM	rd														
	BTST #xx:3,@ERd	B	7	C	0:erd	0	7	3	0:IMM	0										
BTST Rn,Rd	BTST #xx:3,@aa:8	B	7	E	abs		7	3	0:IMM	0										
	BTST #xx:3,@aa:16	B	6	A	1	0	abs	7	3	0:IMM	0									
	BTST #xx:3,@aa:32	B	6	A	3	0	abs					7	3	0:IMM	0					
	BTST Rn,Rd	B	6	3	rn	rd														
	BTST Rn,@ERd	B	7	C	0:erd	0	6	3	rn	0										

Instruc- tion	Mnemonic	Size	Instruction Format																	
			1st byte	2nd byte	3rd byte	4th byte	5th byte	6th byte	7th byte	8th byte	9th byte	10th byte								
BTST	BTST Rn, @aa:8	B	7	E	abs	6	3	0	0											
	BTST Rn, @aa:16	B	6	A	1	0	abs	6	3	0										
	BTST Rn, @aa:32	B	6	A	3	0	abs	6	3	0										
BXOR	BXOR #xx:3,Rd	B	7	5	0:IMM	rd														
	BXOR #xx:3,@ERd	B	7	C	0:erd	0	7	5	0:IMM	0										
	BXOR #xx:3,@aa:8	B	7	E	abs	7	5	0:IMM	0											
	BXOR #xx:3,@aa:16	B	6	A	1	0	abs	7	5	0:IMM	0									
	BXOR #xx:3,@aa:32	B	6	A	3	0	abs	7	5	0:IMM	0									
	CLRMAC	CLRMAC	—	0	1	A	0													
CMP	CMP.B #xx:8,Rd	B	A	rd	IMM															
	CMP.B Rs,Rd	B	1	C	rs	rd														
	CMP.W #xx:16,Rd	W	7	9	2	rd	IMM													
	CMP.W Rs,Rd	W	1	D	rs	rd														
	CMP.L #xx:32,ERd	L	7	A	2	0:erd														
	CMP.L ERs,ERd	L	1	F	1:ers	0:erd														
DAA	DAA Rd	B	0	F	0	rd														
DAS	DAS Rd	B	1	F	0	rd														
DEC	DEC.B Rd	B	1	A	0	rd														
	DEC.W #1,Rd	W	1	B	5	rd														
	DEC.W #2,Rd	W	1	B	D	rd														
	DEC.L #1,ERd	L	1	B	7	0:erd														
	DEC.L #2,ERd	L	1	B	F	0:erd														
	DIVXS	DIVXS.B Rs,Rd	B	0	1	D	0	5	1	rs	rd									
	DIVXS.W Rs,ERd	W	0	1	D	0	5	3	rs	0:erd										
DIVXU	DIVXU.B Rs,Rd	B	5	1	rs	rd														
	DIVXU.W Rs,ERd	W	5	3	rs	0:erd														
	EEPMOV	EEPMOV.B	—	7	B	5	C	5	9	8	F									
	EEPMOV.W	—	7	B	D	4	5	9	8	F										

Instruction	Mnemonic	Size	Instruction Format																				
			1st byte	2nd byte	3rd byte	4th byte	5th byte	6th byte	7th byte	8th byte	9th byte	10th byte											
EXTS	EXTS.W Rd	W	1	7	D	rd																	
	EXTS.L ERd	L	1	7	F	0:erd																	
EXTU	EXTU.W Rd	W	1	7	5	rd																	
	EXTU.L ERd	L	1	7	7	0:erd																	
INC	INC.B Rd	B	0	A	0	rd																	
	INC.W #1,Rd	W	0	B	5	rd																	
	INC.W #2,Rd	W	0	B	D	rd																	
	INC.L #1,ERd	L	0	B	7	0:erd																	
	INC.L #2,ERd	L	0	B	F	0:erd																	
JMP	JMP @ERn	—	5	9	0:ern	0																	
	JMP @aa:24	—	5	A																			
	JMP @ @aa:8	—	5	B	abs																		
JSR	JSR @ERn	—	5	D	0:ern	0																	
	JSR @aa:24	—	5	E																			
	JSR @ @aa:8	—	5	F	abs																		
LDC	LDC #xx:8,CCR	B	0	7	IMM																		
	LDC #xx:8,EXR	B	0	1	4	1	0	7	IMM														
	LDC Rs,CCR	B	0	3	0	rs																	
	LDC Rs,EXR	B	0	3	1	rs																	
	LDC @ERs,CCR	W	0	1	4	0	6	9	0	ers	0												
	LDC @ERs,EXR	W	0	1	4	1	6	9	0	ers	0												
	LDC @(d:16,ERs),CCR	W	0	1	4	0	6	F	0	ers	0												
	LDC @(d:16,ERs),EXR	W	0	1	4	1	6	F	0	ers	0												
	LDC @(d:32,ERs),CCR	W	0	1	4	0	7	8	0	ers	0												
	LDC @(d:32,ERs),EXR	W	0	1	4	1	7	8	0	ers	0												
	LDC @ERs+,CCR	W	0	1	4	0	6	D	0	ers	0												
	LDC @ERs+,EXR	W	0	1	4	1	6	D	0	ers	0												
	LDC @aa:16,CCR	W	0	1	4	0	6	B	0	0													
LDC @aa:16,EXR	W	0	1	4	1	6	B	0	0														



Instruction	Mnemonic	Size	Instruction Format														
			1st byte	2nd byte	3rd byte	4th byte	5th byte	6th byte	7th byte	8th byte	9th byte	10th byte					
LDC	LDC @aa:32,CCR	W	0	1	4	0	0	6	B	2	0						
	LDC @aa:32,EXR	W	0	1	4	1	6	B	2	0							
LDM	LDM.L @SP+, (ERn-ERn+1)	L	0	1	1	0	0	6	D	7	0:ern+1						
	LDM.L @SP+, (ERn-ERn+2)	L	0	1	2	0	0	6	D	7	0:ern+2						
	LDM.L @SP+, (ERn-ERn+3)	L	0	1	3	0	0	6	D	7	0:ern+3						
LDMAC	LDMAC ERs,MACH	L	0	3	2	0:ers											
	LDMAC ERs,MACL	L	0	3	3	0:ers											
MAC	MAC @ERn+,@ERm+	—	0	1	6	0	6	D	0:erm;0:erm								
MOV	MOV.B #xx:8,Rd	B	F	rd	IMM												
	MOV.B Rs,Rd	B	0	C	rs	rd											
	MOV.B @ERs,Rd	B	6	8	0:ers	rd											
	MOV.B @(d:16,ERs),Rd	B	6	E	0:ers	rd	disp										
	MOV.B @(d:32,ERs),Rd	B	7	8	0:ers	0	6	A	2	rd	disp						
	MOV.B @ERs+,Rd	B	6	C	0:ers	rd											
	MOV.B @aa:8,Rd	B	2	rd	abs												
	MOV.B @aa:16,Rd	B	6	A	0	rd	abs										
	MOV.B @aa:32,Rd	B	6	A	2	rd	abs										
	MOV.B Rs,@ERd	B	6	8	1:erd	rs											
	MOV.B Rs,@(d:16,ERd)	B	6	E	1:erd	rs	disp										
	MOV.B Rs,@(d:32,ERd)	B	7	8	0:erd	0	6	A	A	rs	disp						
	MOV.B Rs,@-ERd	B	6	C	1:erd	rs											
	MOV.B Rs,@aa:8	B	3	rs	abs												
	MOV.B Rs,@aa:16	B	6	A	8	rs	abs										
	MOV.B Rs,@aa:32	B	6	A	A	rs	abs										
MOV.W #xx:16,Rd	W	7	9	0	rd	IMM											
MOV.W Rs,Rd	W	0	D	rs	rd												
MOV.W @ERs,Rd	W	6	9	0:ers	rd												
MOV.W @(d:16,ERs),Rd	W	6	F	0:ers	rd	disp											
MOV.W @(d:32,ERs),Rd	W	7	8	0:ers	0	6	B	2	rd	disp							

Instruction	Mnemonic	Size	Instruction Format																	
			1st byte	2nd byte	3rd byte	4th byte	5th byte	6th byte	7th byte	8th byte	9th byte	10th byte								
MOV	MOV.W @ERS+,Rd	W	6	0:ers	rd															
	MOV.W @aa:16,Rd	W	6	B	0	rd	abs													
	MOV.W @aa:32,Rd	W	6	B	2	rd	abs													
	MOV.W Rs,@ERd	W	6	9	1:erd	rs														
	MOV.W Rs,@(d:16,ERd)	W	6	F	1:erd	rs	disp													
	MOV.W Rs,@(d:32,ERd)	W	7	8	0:erd	0	6	B	A	rs	disp									
	MOV.W Rs,@-ERd	W	6	D	1:erd	rs														
	MOV.W Rs,@aa:16	W	6	B	8	rs	abs													
	MOV.W Rs,@aa:32	W	6	B	A	rs	abs													
	MOV.L #xx:32,Rd	L	7	A	0	0:erd	IMM													
	MOV.L ERs,ERd	L	0	F	1:ers	0:erd														
	MOV.L @ERSs,ERd	L	0	1	0	0	6	9	0:ers	0:erd										
	MOV.L @(d:16,ERSs),ERd	L	0	1	0	0	6	F	0:ers	0:erd	disp									
	MOV.L @(d:32,ERSs),ERd	L	0	1	0	0	7	8	0:ers	0	6	B	2	0:erd	disp					
	MOV.L @ERS+,ERd	L	0	1	0	0	6	D	0:ers	0:erd										
	MOV.L @aa:16,ERd	L	0	1	0	0	6	B	0	0:erd	abs									
	MOV.L @aa:32,ERd	L	0	1	0	0	6	B	2	0:erd	abs									
	MOV.L ERs,@ERd	L	0	1	0	0	6	9	1:erd	0:ers										
	MOV.L ERs,@(d:16,ERd)	L	0	1	0	0	6	F	1:erd	0:ers	disp									
	MOV.L ERs,@(d:32,ERd)*1	L	0	1	0	0	7	8	0:erd	0	6	B	A	0:ers	disp					
MOV.L ERs,@-ERd	L	0	1	0	0	6	D	1:erd	0:ers											
MOV.L ERs,@aa:16	L	0	1	0	0	6	B	8	0:ers	abs										
MOV.L ERs,@aa:32	L	0	1	0	0	6	B	A	0:ers	abs										
MOV.FPE MOV.FPE @aa:16,Rd	B	Cannot be used in the H8S/2633 Series																		
MOV.TPE MOV.TPE Rs,@aa:16	B																			
MULXS	MULXS.B Rs,Rd	B	0	1	C	0	5	0	rs	rd										
	MULXS.W Rs,ERd	W	0	1	C	0	5	2	rs	0:erd										
MULXU	MULXU.B Rs,Rd	B	5	0	rs	rd														
	MULXU.W Rs,ERd	W	5	2	rs	0:erd														

Instruc- tion	Mnemonic	Size	Instruction Format																		
			1st byte	2nd byte	3rd byte	4th byte	5th byte	6th byte	7th byte	8th byte	9th byte	10th byte									
NEG	NEG.B Rd	B	1	7	8	rd															
	NEG.W Rd	W	1	7	9	rd															
	NEG.L ERd	L	1	7	B	0:erd															
NOP	NOP	—	0	0	0	0															
NOT	NOT.B Rd	B	1	7	0	rd															
	NOT.W Rd	W	1	7	1	rd															
	NOT.L ERd	L	1	7	3	0:erd															
OR	OR.B #xx:8,Rd	B	C	rd	IMM																
	OR.B Rs,Rd	B	1	4	rs	rd															
	OR.W #xx:16,Rd	W	7	9	4	rd	IMM														
	OR.W Rs,Rd	W	6	4	rs	rd															
	OR.L #xx:32,ERd	L	7	A	4	0:erd															
	OR.L ERs,ERd	L	0	1	F	0	6	4	0:ers	0:erd											
	ORC #xx:8,CCR	B	0	4	IMM																
POP	POP.W Rn	W	6	D	7	rn															
	POP.L ERn	L	0	1	0	0	6	D	7	0:ern											
PUSH	PUSH.W Rn	W	6	D	F	rn															
	PUSH.L ERn	L	0	1	0	0	6	D	F	0:ern											
ROTL	ROTL.B Rd	B	1	2	8	rd															
	ROTL.B #2, Rd	B	1	2	C	rd															
	ROTL.W Rd	W	1	2	9	rd															
	ROTL.W #2, Rd	W	1	2	D	rd															
	ROTL.L ERd	L	1	2	B	0:erd															
ROTL.L #2, ERd	L	1	2	F	0:erd																

Instruction	Mnemonic	Size	Instruction Format																	
			1st byte	2nd byte	3rd byte	4th byte	5th byte	6th byte	7th byte	8th byte	9th byte	10th byte								
ROTR	ROTR.B Rd	B	1	3	8	rd														
	ROTR.B #2, Rd	B	1	3	C	rd														
	ROTR.W Rd	W	1	3	9	rd														
	ROTR.W #2, Rd	W	1	3	D	rd														
	ROTR.L ERd	L	1	3	B	:0: erd														
	ROTR.L #2, ERd	L	1	3	F	:0: erd														
	ROTXL.B Rd	B	1	2	0	rd														
	ROTXL.B #2, Rd	B	1	2	4	rd														
ROTXR	ROTXR.W Rd	W	1	2	1	rd														
	ROTXR.W #2, Rd	W	1	2	5	rd														
	ROTXR.L ERd	L	1	2	3	:0: erd														
	ROTXR.L #2, ERd	L	1	2	7	:0: erd														
	ROTXR.B Rd	B	1	3	0	rd														
	ROTXR.B #2, Rd	B	1	3	4	rd														
SHAL	SHAL.W Rd	W	1	3	1	rd														
	SHAL.W #2, Rd	W	1	3	5	rd														
	SHAL.L ERd	L	1	3	3	:0: erd														
	SHAL.L #2, ERd	L	1	3	7	:0: erd														
	RTE		5	6	7	0														
	RTS		5	4	7	0														
	SHAL.B Rd	B	1	0	8	rd														
	SHAL.B #2, Rd	B	1	0	C	rd														
SHAL.W Rd	SHAL.W Rd	W	1	0	9	rd														
	SHAL.W #2, Rd	W	1	0	D	rd														
	SHAL.L ERd	L	1	0	B	:0: erd														
	SHAL.L #2, ERd	L	1	0	F	:0: erd														

Instruc- tion	Mnemonic	Size	Instruction Format																				
			1st byte	2nd byte	3rd byte	4th byte	5th byte	6th byte	7th byte	8th byte	9th byte	10th byte											
SHAR	SHAR.B Rd	B	1	1	8	rd																	
	SHAR.B #2, Rd	B	1	1	C	rd																	
	SHAR.W Rd	W	1	1	9	rd																	
	SHAR.W #2, Rd	W	1	1	D	rd																	
	SHAR.L ERd	L	1	1	B	0: erd																	
	SHAR.L #2, ERd	L	1	1	F	0: erd																	
	SHLL	SHLL.B Rd	B	1	0	0	rd																
	SHLL.B #2, Rd	B	1	0	4	rd																	
	SHLL.W Rd	W	1	0	1	rd																	
	SHLL.W #2, Rd	W	1	0	5	rd																	
	SHLL.L ERd	L	1	0	3	0: erd																	
	SHLL.L #2, ERd	L	1	0	7	0: erd																	
SHLR	SHLR.B Rd	B	1	1	0	rd																	
	SHLR.B #2, Rd	B	1	1	4	rd																	
	SHLR.W Rd	W	1	1	1	rd																	
	SHLR.W #2, Rd	W	1	1	5	rd																	
	SHLR.L ERd	L	1	1	3	0: erd																	
	SHLR.L #2, ERd	L	1	1	7	0: erd																	
	SLEEP	SLEEP	—	0	1	8	0																
STC	STC.B CCR,Rd	B	0	2	0	rd																	
	STC.B EXR,Rd	B	0	2	1	rd																	
	STC.W CCR,@ERd	W	0	1	4	0	6	9	1	erd	0												
	STC.W EXR,@ERd	W	0	1	4	1	6	9	1	erd	0												
	STC.W CCR,@(d:16,ERd)	W	0	1	4	0	6	F	1	erd	0												
	STC.W EXR,@(d:16,ERd)	W	0	1	4	1	6	F	1	erd	0												
	STC.W CCR,@(d:32,ERd)	W	0	1	4	0	7	8	0	erd	0	6	B	A	0							disp	
	STC.W EXR,@(d:32,ERd)	W	0	1	4	1	7	8	0	erd	0	6	B	A	0							disp	
	STC.W CCR,@-ERd	W	0	1	4	0	6	D	1	erd	0												
	STC.W EXR,@-ERd	W	0	1	4	1	6	D	1	erd	0												

Instruction	Mnemonic	Size	Instruction Format																	
			1st byte	2nd byte	3rd byte	4th byte	5th byte	6th byte	7th byte	8th byte	9th byte	10th byte								
STC	STC.W CCR, @aa:16	W	0 1	4 0	6 B	8 0	abs													
	STC.W EXR, @aa:16	W	0 1	4 1	6 B	8 0	abs													
	STC.W CCR, @aa:32	W	0 1	4 0	6 B	A 0	abs													
	STC.W EXR, @aa:32	W	0 1	4 1	6 B	A 0	abs													
STM	STM.L(ERn-ERn+1), @-SP	L	0 1	1 0	6 D	F 0:ern														
	STM.L(ERn-ERn+2), @-SP	L	0 1	2 0	6 D	F 0:ern														
	STM.L(ERn-ERn+3), @-SP	L	0 1	3 0	6 D	F 0:ern														
STMAC	STMAC MACH,ERd	L	0 2	2 0:ers																
	STMAC MACL,ERd	L	0 2	3 0:ers																
SUB	SUB.B Rs,Rd	B	1 8	rs rd																
	SUB.W #xx:16,Rd	W	7 9	3 rd		IMM														
	SUB.W Rs,Rd	W	1 9	rs rd																
	SUB.L #xx:32,ERd	L	7 A	3 0:erd			IMM													
	SUB.L ERs,ERd	L	1 A	1:ers 0:erd																
SUBS	SUBS #1,ERd	L	1 B	0 0:erd																
	SUBS #2,ERd	L	1 B	8 0:erd																
	SUBS #4,ERd	L	1 B	9 0:erd																
SUBX	SUBX #xx:8,Rd	B	B rd	IMM																
	SUBX Rs,Rd	B	1 E	rs rd																
TAS#2	TAS @ERd	B	0 1	E 0	7 B	0:erd C														
TRAPA	TRAPA #x:2	—	5 7	00:IMM 0																
XOR	XOR.B #xx:8,Rd	B	D rd	IMM																
	XOR.B Rs,Rd	B	1 5	rs rd																
	XOR.W #xx:16,Rd	W	7 9	5 rd		IMM														
	XOR.W Rs,Rd	W	6 5	rs rd																
	XOR.L #xx:32,ERd	L	7 A	5 0:erd			IMM													
XOR.L ERs,ERd	L	0 1	F 0	6 5	0:ers 0:erd															

Instruction	Mnemonic	Size	Instruction Format												
			1st byte	2nd byte	3rd byte	4th byte	5th byte	6th byte	7th byte	8th byte	9th byte	10th byte			
XORC	XORC #xx:8:CCR	B	0	5	IMM										
	XORC #xx:8:EXR	B	0	1	4	1	0	5	IMM						

Notes: \*1 Bit 7 of the 4th byte of the MOV.L ERs, @(d:32,ERd) instruction can be either 1 or 0.

\*2 When using the TAS instruction, use register ER0, ER1, ER4, or ER5.

#### Legend

IMM:

Immediate data (2, 3, 8, 16, or 32 bits)

abs:

Absolute address (8, 16, 24, or 32 bits)

disp:

Displacement (8, 16, or 32 bits)

rs, rd, rn:

Register field (4 bits specifying an 8-bit or 16-bit register. The symbols rs, rd, and rn correspond to operand symbols Rs, Rd, and Rn.)

ers, erd, erm, erm:

Register field (3 bits specifying an address register or 32-bit register. The symbols ers, erd, erm, and erm correspond to operand symbols ERs, ERd, ERn, and ERm.)

The register fields specify general registers as follows.

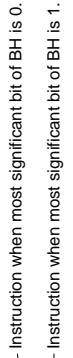
Address Register		16-Bit Register		8-Bit Register	
32-Bit Register	General Register	Register Field	General Register	Register Field	General Register
000	ER0	0000	R0	0000	R0H
001	ER1	0001	R1	0001	R1H
•	•	•	•	•	•
•	•	•	•	•	•
•	•	•	•	•	•
111	ER7	0111	R7	0111	R7H
		1000	E0	1000	R0L
		1001	E1	1001	R1L
		•	•	•	•
		•	•	•	•
		•	•	•	•
		1111	E7	1111	R7L

## A.3 Operation Code Map

Table A-3 shows the operation code map.

**Table A-3 Operation Code Map (1)**

Instruction code		1st byte		2nd byte												
AL	AH	1	2	3	4	5	6	7	8	9	A	B	C	D	E	F
0	NOP	Table A.3(2)	STC	LDC	ORC	XORC	ANDC	LDC	ADD	ADD	Table A.3(2)	Table A.3(2)	MOV	ADDX		Table A.3(2)
1	Table A.3(2)	Table A.3(2)	STMAC	LDMAC*	OR	XOR	AND	Table A.3(2)	SUB	SUB	Table A.3(2)	Table A.3(2)	CMP	CMP	SUBX	Table A.3(2)
2																
3																
4	BRA	BRN	BHI	BLS	BCC	BCS	BNE	BEQ	BVC	BVS	BPL	BMI	BGE	BLT	BGT	BLE
5	MULXU	DIVXU	MULXU	DIVXU	RTS	BSR	RTE	TRAPA	Table A.3(2)		JMP		BSR		JSR	
6	BSET	BNOT	BCLR	BTST	OR	XOR	AND	BST	MOV	MOV	Table A.3(2)			MOV		
7					BOR	BXOR	BAND	BLD	MOV	Table A.3(2)	EEP	MOV				
8					BIOR	BIXOR	BIAND	BILD	ADD							
9									ADDX							
A									CMP							
B									SUBX							
C									OR							
D									XOR							
E									AND							
F									MOV							



Note: \* Cannot be used in the H8S/2633 Series.



**Table A-3 Operation Code Map (2)**

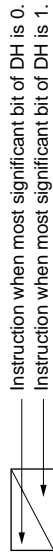
Instruction code		1st byte		2nd byte	
BH	AH	AL	AL	BH	BL

BH	AH	0	1	2	3	4	5	6	7	8	9	A	B	C	D	E	F
01	MOV	LDM	LDC	STM	STC	MAC*	SLEEP	CLRMAC*	Table A.3(3)	Table A.3(3)	Table A.3(3)	Table A.3(3)	Table A.3(3)	Table A.3(3)	Table A.3(3)	TAS	Table A.3(3)
0A	INC	ADD															
0B	ADDS	INC															
0F	DAA	MOV															
10	SHLL	SHLL	SHLL	SHLL	SHLL	SHLL	SHAL	SHAL	SHLL	SHAL	SHAL	SHAL	SHAL	SHAL	SHAL	SHAL	SHAL
11	SHLR	SHLR	SHLR	SHLR	SHLR	SHLR	SHAR	SHAR	SHLR	SHAR	SHAR	SHAR	SHAR	SHAR	SHAR	SHAR	SHAR
12	ROTXL	ROTXL	ROTXL	ROTXL	ROTXL	ROTXL	ROTL	ROTL	ROTXL	ROTL	ROTL	ROTL	ROTL	ROTL	ROTL	ROTL	ROTL
13	ROTXR	ROTXR	ROTXR	ROTXR	ROTXR	ROTXR	ROTR	ROTR	ROTXR	ROTR	ROTR	ROTR	ROTR	ROTR	ROTR	ROTR	ROTR
17	NOT	NOT	EXTU	EXTU	EXTU	EXTU	NEG	NEG	EXTU	NEG	NEG	NEG	NEG	NEG	EXTS	EXTS	EXTS
1A	DEC	SUB															
1B	SUBS	DEC															
1F	DAS	CMP															
58	BRA	BRN	BHI	BLS	BCC	BNE	BVC	BPL	BEQ	BVS	BMI	BGT	BGE	BGT	BGT	BGT	BLE
6A	MOV	MOV	MOV	MOV	MOV	MOV	MOV	MOV	MOV	MOV	MOV	MOV	MOV	MOV	MOV	MOV	MOV
79	MOV	ADD	CMP	SUB	OR	XOR	AND	AND	AND	AND	AND	AND	AND	AND	AND	AND	AND
7A	MOV	ADD	CMP	SUB	OR	XOR	AND	AND	AND	AND	AND	AND	AND	AND	AND	AND	AND

Note: \* Cannot be used in the H8S/2633 Series.

**Table A-3 Operation Code Map (3)**

Instruction code	1st byte		2nd byte			3rd byte			4th byte	
	AH	AL	BH	BL	CH	CL	CH	CL	DH	DL



	0	1	2	3	4	5	6	7	8	9	A	B	C	D	E	F
CL	CL	CL	CL	CL	CL	CL	CL	CL	CL	CL	CL	CL	CL	CL	CL	CL
AH-AL	MULXS	MULXS	MULXS													
BH-BL		DIVXS		DIVXS												
CH-CL					OR	XOR	AND									
01C05	MULXS															
01D05		DIVXS		DIVXS												
01F06																
7Cr06 *1				BTST												
7Cr07 *1				BTST	BOR	BXOR	BAND	BLD	BIOR	BIXOR	BIAND	BILD	BIST			
7Dr06 *1	BSET	BNOT	BCLR													
7Dr07 *1	BSET	BNOT	BCLR													
7Eaa6 *2				BTST												
7Eaa7 *2				BTST	BOR	BXOR	BAND	BLD	BIOR	BIXOR	BIAND	BILD	BIST			
7Faa6 *2	BSET	BNOT	BCLR													
7Faa7 *2	BSET	BNOT	BCLR													

Notes: \*1 r is the register specification field.  
 \*2 aa is the absolute address specification.

**Table A-3 Operation Code Map (4)**

Instruction code		1st byte		2nd byte		3rd byte		4th byte		5th byte		6th byte					
		AH	AL	BH	BL	CH	CL	DH	DL	EH	EL	FH	FL				
EL	Instruction when most significant bit of FH is 0.	0	1	2	3	4	5	6	7	8	9	A	B	C	D	E	F
AH BH CH DH EH																	
6A10aaaa6*																	
6A10aaaa7*																	
6A18aaaa6*																	
6A18aaaa7*																	

Instruction code		1st byte		2nd byte		3rd byte		4th byte		5th byte		6th byte		7th byte		8th byte	
		AH	AL	BH	BL	CH	CL	DH	DL	EH	EL	FL	GH	GL	HH	HL	
GL	Instruction when most significant bit of HH is 0.	0	1	2	3	4	5	6	7	8	9	A	B	C	D	E	F
AH BH CH DH EH																	
6A30aaaaaaaa6*																	
6A30aaaaaaaa7*																	
6A38aaaaaaaa6*																	
6A38aaaaaaaa7*																	

Note: \* aa is the absolute address specification.

## A.4 Number of States Required for Instruction Execution

The tables in this section can be used to calculate the number of states required for instruction execution by the CPU. Table A-5 indicates the number of instruction fetch, data read/write, and other cycles occurring in each instruction. Table A-4 indicates the number of states required for each cycle. The number of states required for execution of an instruction can be calculated from these two tables as follows:

$$\text{Execution states} = I \times S_I + J \times S_J + K \times S_K + L \times S_L + M \times S_M + N \times S_N$$

**Examples:** Advanced mode, program code and stack located in external memory, on-chip supporting modules accessed in two states with 8-bit bus width, external devices accessed in three states with one wait state and 16-bit bus width.

1. BSET #0, @FFFFC7:8

From table A-5:

$$I = L = 2, \quad J = K = M = N = 0$$

From table A-4:

$$S_I = 4, \quad S_L = 2$$

$$\text{Number of states required for execution} = 2 \times 4 + 2 \times 2 = 12$$

2. JSR @@30

From table A-5:

$$I = J = K = 2, \quad L = M = N = 0$$

From table A-4:

$$S_I = S_J = S_K = 4$$

$$\text{Number of states required for execution} = 2 \times 4 + 2 \times 4 + 2 \times 4 = 24$$

**Table A-4 Number of States per Cycle**

Cycle		On-Chip Memory	Access Conditions					
			On-Chip Supporting Module		External Device			
			8-Bit Bus	16-Bit Bus	8-Bit Bus		16-Bit Bus	
				2-State Access	3-State Access	2-State Access	3-State Access	
Instruction fetch	$S_I$	1	4	2	4	6 + 2m	2	3 + m
Branch address read	$S_J$							
Stack operation	$S_K$							
Byte data access	$S_L$		2		2	3 + m		
Word data access	$S_M$		4		4	6 + 2m		
Internal operation	$S_N$	1	1	1	1	1	1	1

**Legend**

m: Number of wait states inserted into external device access

**Table A-5 Number of Cycles in Instruction Execution**

Instruction	Mnemonic	Instruction	Branch	Stack	Byte	Word	Internal
		Fetch	Address	Operation	Data	Data	Operation
		I	J	K	L	M	N
ADD	ADD.B #xx:8,Rd	1					
	ADD.B Rs,Rd	1					
	ADD.W #xx:16,Rd	2					
	ADD.W Rs,Rd	1					
	ADD.L #xx:32,ERd	3					
	ADD.L ERs,ERd	1					
ADDS	ADDS #1/2/4,ERd	1					
ADDX	ADDX #xx:8,Rd	1					
	ADDX Rs,Rd	1					
AND	AND.B #xx:8,Rd	1					
	AND.B Rs,Rd	1					
	AND.W #xx:16,Rd	2					
	AND.W Rs,Rd	1					
	AND.L #xx:32,ERd	3					
	AND.L ERs,ERd	2					
ANDC	ANDC #xx:8,CCR	1					
	ANDC #xx:8,EXR	2					
BAND	BAND #xx:3,Rd	1					
	BAND #xx:3,@ERd	2			1		
	BAND #xx:3,@aa:8	2			1		
	BAND #xx:3,@aa:16	3			1		
	BAND #xx:3,@aa:32	4			1		
Bcc	BRA d:8 (BT d:8)	2					
	BRN d:8 (BF d:8)	2					
	BHI d:8	2					
	BLS d:8	2					
	BCC d:8 (BHS d:8)	2					
	BCS d:8 (BLO d:8)	2					
	BNE d:8	2					
	BEQ d:8	2					
	BVC d:8	2					
	BVS d:8	2					
	BPL d:8	2					

Instruction	Mnemonic	Instruction	Branch	Stack	Byte	Word	Internal
		Fetch	Address	Operation	Data	Data	Operation
		I	J	K	L	M	N
Bcc	BMI d:8	2					
	BGE d:8	2					
	BLT d:8	2					
	BGT d:8	2					
	BLE d:8	2					
	BRA d:16 (BT d:16)	2					1
	BRN d:16 (BF d:16)	2					1
	BHI d:16	2					1
	BLS d:16	2					1
	BCC d:16 (BHS d:16)	2					1
	BCS d:16 (BLO d:16)	2					1
	BNE d:16	2					1
	BEQ d:16	2					1
	BVC d:16	2					1
	BVS d:16	2					1
	BPL d:16	2					1
	BMI d:16	2					1
	BGE d:16	2					1
	BLT d:16	2					1
	BGT d:16	2					1
BLE d:16	2					1	
BCLR	BCLR #xx:3,Rd	1					
	BCLR #xx:3,@ERd	2			2		
	BCLR #xx:3,@aa:8	2			2		
	BCLR #xx:3,@aa:16	3			2		
	BCLR #xx:3,@aa:32	4			2		
	BCLR Rn,Rd	1					
	BCLR Rn,@ERd	2			2		
	BCLR Rn,@aa:8	2			2		
	BCLR Rn,@aa:16	3			2		
	BCLR Rn,@aa:32	4			2		

Instruction	Mnemonic	Instruction	Branch	Stack	Byte	Word	Internal
		Fetch	Address	Operation	Data	Data	Operation
		I	J	K	L	M	N
BIAND	BIAND #xx:3,Rd	1					
	BIAND #xx:3,@ERd	2			1		
	BIAND #xx:3,@aa:8	2			1		
	BIAND #xx:3,@aa:16	3			1		
	BIAND #xx:3,@aa:32	4			1		
BILD	BILD #xx:3,Rd	1					
	BILD #xx:3,@ERd	2			1		
	BILD #xx:3,@aa:8	2			1		
	BILD #xx:3,@aa:16	3			1		
	BILD #xx:3,@aa:32	4			1		
BIOR	BIOR #xx:8,Rd	1					
	BIOR #xx:8,@ERd	2			1		
	BIOR #xx:8,@aa:8	2			1		
	BIOR #xx:8,@aa:16	3			1		
	BIOR #xx:8,@aa:32	4			1		
BIST	BIST #xx:3,Rd	1					
	BIST #xx:3,@ERd	2			2		
	BIST #xx:3,@aa:8	2			2		
	BIST #xx:3,@aa:16	3			2		
	BIST #xx:3,@aa:32	4			2		
BIXOR	BIXOR #xx:3,Rd	1					
	BIXOR #xx:3,@ERd	2			1		
	BIXOR #xx:3,@aa:8	2			1		
	BIXOR #xx:3,@aa:16	3			1		
	BIXOR #xx:3,@aa:32	4			1		
BLD	BLD #xx:3,Rd	1					
	BLD #xx:3,@ERd	2			1		
	BLD #xx:3,@aa:8	2			1		
	BLD #xx:3,@aa:16	3			1		
	BLD #xx:3,@aa:32	4			1		



Instruction	Mnemonic	Instruction	Branch	Stack	Byte	Word	Internal
		Fetch	Address	Operation	Data	Data	Operation
		I	J	K	L	M	N
BNOT	BNOT #xx:3,Rd	1					
	BNOT #xx:3,@ERd	2			2		
	BNOT #xx:3,@aa:8	2			2		
	BNOT #xx:3,@aa:16	3			2		
	BNOT #xx:3,@aa:32	4			2		
	BNOT Rn,Rd	1					
	BNOT Rn,@ERd	2				2	
	BNOT Rn,@aa:8	2				2	
	BNOT Rn,@aa:16	3				2	
BNOT Rn,@aa:32	4				2		
BOR	BOR #xx:3,Rd	1					
	BOR #xx:3,@ERd	2			1		
	BOR #xx:3,@aa:8	2			1		
	BOR #xx:3,@aa:16	3			1		
	BOR #xx:3,@aa:32	4			1		
BSET	BSET #xx:3,Rd	1					
	BSET #xx:3,@ERd	2			2		
	BSET #xx:3,@aa:8	2			2		
	BSET #xx:3,@aa:16	3			2		
	BSET #xx:3,@aa:32	4			2		
	BSET Rn,Rd	1					
	BSET Rn,@ERd	2				2	
	BSET Rn,@aa:8	2				2	
	BSET Rn,@aa:16	3				2	
BSET Rn,@aa:32	4				2		
BSR	BSR d:8	2		2			
	BSR d:16	2		2			1
BST	BST #xx:3,Rd	1					
	BST #xx:3,@ERd	2			2		
	BST #xx:3,@aa:8	2			2		
	BST #xx:3,@aa:16	3			2		
	BST #xx:3,@aa:32	4			2		

Instruction	Mnemonic	Instruction	Branch	Stack	Byte	Word	Internal
		Fetch	Address	Operation	Data	Data	Operation
		I	J	K	L	M	N
BTST	BTST #xx:3,Rd	1					
	BTST #xx:3,@ERd	2			1		
	BTST #xx:3,@aa:8	2			1		
	BTST #xx:3,@aa:16	3			1		
	BTST #xx:3,@aa:32	4			1		
	BTST Rn,Rd	1					
	BTST Rn,@ERd	2			1		
	BTST Rn,@aa:8	2			1		
	BTST Rn,@aa:16	3			1		
BTST Rn,@aa:32	4			1			
BXOR	BXOR #xx:3,Rd	1					
	BXOR #xx:3,@ERd	2			1		
	BXOR #xx:3,@aa:8	2			1		
	BXOR #xx:3,@aa:16	3			1		
	BXOR #xx:3,@aa:32	4			1		
CLRMAC	CLRMAC	1					1*3
CMP	CMP.B #xx:8,Rd	1					
	CMP.B Rs,Rd	1					
	CMP.W #xx:16,Rd	2					
	CMP.W Rs,Rd	1					
	CMP.L #xx:32,ERd	3					
CMP.L ERs,ERd	1						
DAA	DAA Rd	1					
DAS	DAS Rd	1					
DEC	DEC.B Rd	1					
	DEC.W #1/2,Rd	1					
	DEC.L #1/2,ERd	1					
DIVXS	DIVXS.B Rs,Rd	2					11
	DIVXS.W Rs,ERd	2					19
DIVXU	DIVXU.B Rs,Rd	1					11
	DIVXU.W Rs,ERd	1					19

Instruction	Mnemonic	Instruction	Branch	Stack	Byte	Word	Internal
		Fetch	Address	Operation	Data	Data	Operation
		I	J	K	L	M	N
EEPMOV	EEPMOV.B	2			2n+2*2		
	EEPMOV.W	2			2n+2*2		
EXTS	EXTS.W Rd	1					
	EXTS.L ERd	1					
EXTU	EXTU.W Rd	1					
	EXTU.L ERd	1					
INC	INC.B Rd	1					
	INC.W #1/2,Rd	1					
	INC.L #1/2,ERd	1					
JMP	JMP @ERn	2					
	JMP @aa:24	2					1
	JMP @@aa:8	2	2				1
JSR	JSR @ERn	2		2			
	JSR @aa:24	2		2			1
	JSR @@aa:8	2	2	2			
LDC	LDC #xx:8,CCR	1					
	LDC #xx:8,EXR	2					
	LDC Rs,CCR	1					
	LDC Rs,EXR	1					
	LDC @ERs,CCR	2				1	
	LDC @ERs,EXR	2				1	
	LDC @(d:16,ERs),CCR	3				1	
	LDC @(d:16,ERs),EXR	3				1	
	LDC @(d:32,ERs),CCR	5				1	
	LDC @(d:32,ERs),EXR	5				1	
	LDC @ERs+,CCR	2				1	1
	LDC @ERs+,EXR	2				1	1
	LDC @aa:16,CCR	3				1	
	LDC @aa:16,EXR	3				1	
	LDC @aa:32,CCR	4				1	
LDC @aa:32,EXR	4				1		

Instruction	Mnemonic	Instruction	Branch	Stack	Byte	Word	Internal
		Fetch	Address	Operation	Data	Data	Operation
		I	J	K	L	M	N
LDM	LDM.L @SP+, (ERn-ERn+1)	2		4			1
	LDM.L @SP+, (ERn-ERn+2)	2		6			1
	LDM.L @SP+, (ERn-ERn+3)	2		8			1
LDMAC	LDMAC ERs,MACH	1					1*3
	LDMAC ERs,MACL	1					1*3
MAC	MAC @ERn+,@ERm+	2				2	
MOV	MOV.B #xx:8,Rd	1					
	MOV.B Rs,Rd	1					
	MOV.B @ERs,Rd	1			1		
	MOV.B @(d:16,ERs),Rd	2			1		
	MOV.B @(d:32,ERs),Rd	4			1		
	MOV.B @ERs+,Rd	1			1		1
	MOV.B @aa:8,Rd	1			1		
	MOV.B @aa:16,Rd	2			1		
	MOV.B @aa:32,Rd	3			1		
	MOV.B Rs,@ERd	1			1		
	MOV.B Rs,@(d:16,ERd)	2			1		
	MOV.B Rs,@(d:32,ERd)	4			1		
	MOV.B Rs,@-ERd	1			1		1
	MOV.B Rs,@aa:8	1			1		
	MOV.B Rs,@aa:16	2			1		
	MOV.B Rs,@aa:32	3			1		
	MOV.W #xx:16,Rd	2					
	MOV.W Rs,Rd	1					
	MOV.W @ERs,Rd	1					1
	MOV.W @(d:16,ERs),Rd	2					1
MOV.W @(d:32,ERs),Rd	4					1	
MOV.W @ERs+,Rd	1					1	1
MOV.W @aa:16,Rd	2					1	
MOV.W @aa:32,Rd	3					1	
MOV.W Rs,@ERd	1					1	

Instruction	Mnemonic	Instruction		Branch	Stack	Byte	Word	Internal
		Fetch	Address	Address	Operation	Data	Data	
		I	J	K	L	M	N	
MOV	MOV.W Rs,@(d:16,ERd)	2				1		
	MOV.W Rs,@(d:32,ERd)	4				1		
	MOV.W Rs,@-ERd	1				1		1
	MOV.W Rs,@aa:16	2				1		
	MOV.W Rs,@aa:32	3				1		
	MOV.L #xx:32,ERd	3						
	MOV.L ERs,ERd	1						
	MOV.L @ERs,ERd	2					2	
	MOV.L @(d:16,ERs),ERd	3					2	
	MOV.L @(d:32,ERs),ERd	5					2	
	MOV.L @ERs+,ERd	2					2	1
	MOV.L @aa:16,ERd	3					2	
	MOV.L @aa:32,ERd	4					2	
	MOV.L ERs,@ERd	2					2	
	MOV.L ERs,@(d:16,ERd)	3					2	
	MOV.L ERs,@(d:32,ERd)	5					2	
	MOV.L ERs,@-ERd	2					2	1
	MOV.L ERs,@aa:16	3					2	
MOV.L ERs,@aa:32	4					2		
MOVFPPE	MOVFPPE @:aa:16,Rd	Can not be used in the H8S/2633 Series						
MOVTPE	MOVTPE Rs,@:aa:16							
MULXS	MULXS.B Rs,Rd	2						2*3
	MULXS.W Rs,ERd	2						3*3
MULXU	MULXU.B Rs,Rd	1						2*3
	MULXU.W Rs,ERd	1						3*3
NEG	NEG.B Rd	1						
	NEG.W Rd	1						
	NEG.L ERd	1						
NOP	NOP	1						
NOT	NOT.B Rd	1						
	NOT.W Rd	1						
	NOT.L ERd	1						

Instruction	Mnemonic	Instruction	Branch	Stack	Byte	Word	Internal
		Fetch	Address	Operation	Data	Data	Operation
		I	J	K	L	M	N
OR	OR.B #xx:8,Rd	1					
	OR.B Rs,Rd	1					
	OR.W #xx:16,Rd	2					
	OR.W Rs,Rd	1					
	OR.L #xx:32,ERd	3					
	OR.L ERs,ERd	2					
ORC	ORC #xx:8,CCR	1					
	ORC #xx:8,EXR	2					
POP	POP.W Rn	1				1	1
	POP.L ERn	2				2	1
PUSH	PUSH.W Rn	1				1	1
	PUSH.L ERn	2				2	1
ROTL	ROTL.B Rd	1					
	ROTL.B #2,Rd	1					
	ROTL.W Rd	1					
	ROTL.W #2,Rd	1					
	ROTL.L ERd	1					
	ROTL.L #2,ERd	1					
ROTR	ROTR.B Rd	1					
	ROTR.B #2,Rd	1					
	ROTR.W Rd	1					
	ROTR.W #2,Rd	1					
	ROTR.L ERd	1					
	ROTR.L #2,ERd	1					
ROTXL	ROTXL.B Rd	1					
	ROTXL.B #2,Rd	1					
	ROTXL.W Rd	1					
	ROTXL.W #2,Rd	1					
	ROTXL.L ERd	1					
	ROTXL.L #2,ERd	1					

Instruction	Mnemonic	Instruction	Branch	Stack	Byte	Word	Internal
		Fetch	Address	Operation	Data	Data	Operation
		I	J	K	L	M	N
ROTXR	ROTXR.B Rd	1					
	ROTXR.B #2,Rd	1					
	ROTXR.W Rd	1					
	ROTXR.W #2,Rd	1					
	ROTXR.L ERd	1					
	ROTXR.L #2,ERd	1					
RTE	RTE	2		2/3* <sup>1</sup>			1
RTS	RTS	2		2			1
SHAL	SHAL.B Rd	1					
	SHAL.B #2,Rd	1					
	SHAL.W Rd	1					
	SHAL.W #2,Rd	1					
	SHAL.L ERd	1					
	SHAL.L #2,ERd	1					
SHAR	SHAR.B Rd	1					
	SHAR.B #2,Rd	1					
	SHAR.W Rd	1					
	SHAR.W #2,Rd	1					
	SHAR.L ERd	1					
	SHAR.L #2,ERd	1					
SHLL	SHLL.B Rd	1					
	SHLL.B #2,Rd	1					
	SHLL.W Rd	1					
	SHLL.W #2,Rd	1					
	SHLL.L ERd	1					
	SHLL.L #2,ERd	1					
SHLR	SHLR.B Rd	1					
	SHLR.B #2,Rd	1					
	SHLR.W Rd	1					
	SHLR.W #2,Rd	1					
	SHLR.L ERd	1					
	SHLR.L #2,ERd	1					
SLEEP	SLEEP	1					1

Instruction	Mnemonic	Instruction	Branch	Stack	Byte	Word	Internal
		Fetch	Address	Operation	Data	Data	Operation
		I	J	K	L	M	N
STC	STC.B CCR,Rd	1					
	STC.B EXR,Rd	1					
	STC.W CCR,@ERd	2				1	
	STC.W EXR,@ERd	2				1	
	STC.W CCR,@(d:16,ERd)	3				1	
	STC.W EXR,@(d:16,ERd)	3				1	
	STC.W CCR,@(d:32,ERd)	5				1	
	STC.W EXR,@(d:32,ERd)	5				1	
	STC.W CCR,@-ERd	2				1	1
	STC.W EXR,@-ERd	2				1	1
	STC.W CCR,@aa:16	3				1	
	STC.W EXR,@aa:16	3				1	
	STC.W CCR,@aa:32	4				1	
	STC.W EXR,@aa:32	4				1	
	STM	STM.L (ERn-ERn+1), @-SP	2		4		
STM.L (ERn-ERn+2), @-SP		2		6			1
STM.L (ERn-ERn+3), @-SP		2		8			1
STMAC	STMAC MACH,ERd	1					*3
	STMAC MACL,ERd	1					*3
SUB	SUB.B Rs,Rd	1					
	SUB.W #xx:16,Rd	2					
	SUB.W Rs,Rd	1					
	SUB.L #xx:32,ERd	3					
	SUB.L ERs,ERd	1					
SUBS	SUBS #1/2/4,ERd	1					
SUBX	SUBX #xx:8,Rd	1					
	SUBX Rs,Rd	1					
TAS*4	TAS @ERd	2			2		
TRAPA	TRAPA #x:2	2	2	2/3*1			2



Instruction	Mnemonic	Instruction	Branch	Stack	Byte	Word	Internal
		Fetch	Address	Operation	Data	Data	
		I	J	K	L	M	N
XOR	XOR.B #xx:8,Rd	1					
	XOR.B Rs,Rd	1					
	XOR.W #xx:16,Rd	2					
	XOR.W Rs,Rd	1					
	XOR.L #xx:32,ERd	3					
	XOR.L ERs,ERd	2					
XORC	XORC #xx:8,CCR	1					
	XORC #xx:8,EXR	2					

Notes: \*1 2 when EXR is invalid, 3 when EXR is valid.

\*2 When n bytes of data are transferred.

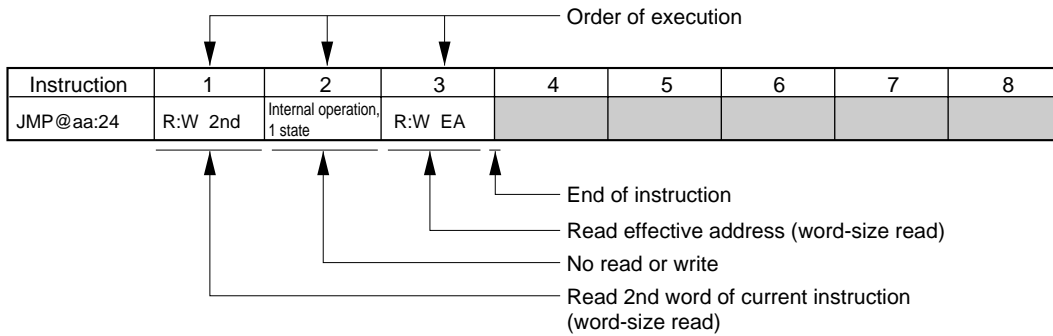
\*3 An internal operation may require between 0 and 3 additional states, depending on the preceding instruction.

\*4 When using the TAS instruction, use register ER0, ER1, ER4, or ER5.

## A.5 Bus States During Instruction Execution

Table A-6 indicates the types of cycles that occur during instruction execution by the CPU. See table A-4 for the number of states per cycle.

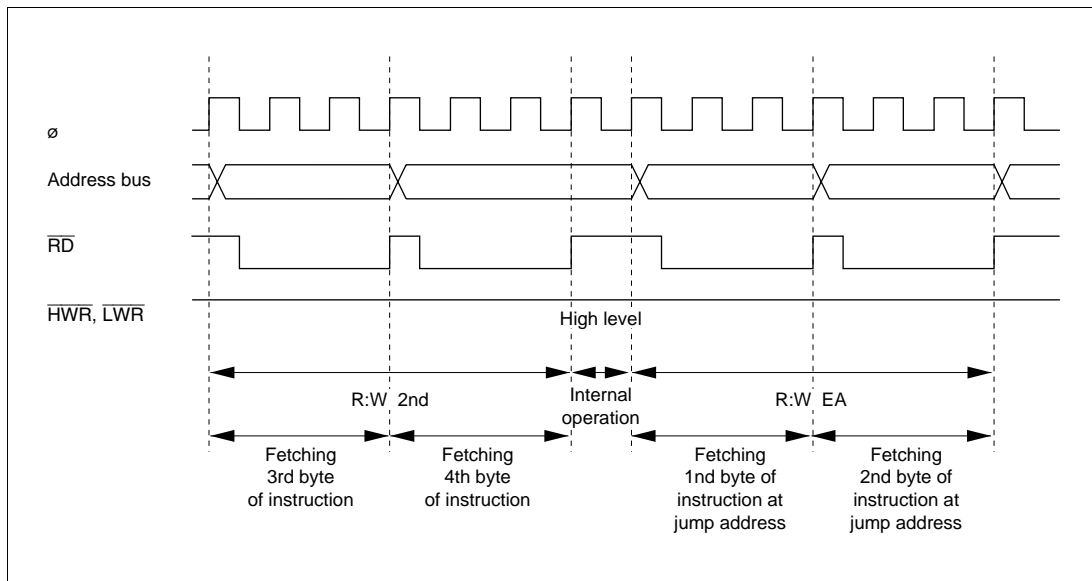
### How to Read the Table:



### Legend

R:B	Byte-size read
R:W	Word-size read
W:B	Byte-size write
W:W	Word-size write
:M	Transfer of the bus is not performed immediately after this cycle
2nd	Address of 2nd word (3rd and 4th bytes)
3rd	Address of 3rd word (5th and 6th bytes)
4th	Address of 4th word (7th and 8th bytes)
5th	Address of 5th word (9th and 10th bytes)
NEXT	Address of next instruction
EA	Effective address
VEC	Vector address

Figure A-1 shows timing waveforms for the address bus and the  $\overline{RD}$ ,  $\overline{HWR}$ , and  $\overline{LWR}$  signals during execution of the above instruction with an 8-bit bus, using three-state access with no wait states.



**Figure A-1 Address Bus,  $\overline{RD}$ ,  $\overline{HWR}$ , and  $\overline{LWR}$  Timing  
(8-Bit Bus, Three-State Access, No Wait States)**

**Table A-6 Instruction Execution Cycles**

Instruction	1	2	3	4	5	6	7	8	9
ADD.B #xx:8,Rd	R:W NEXT								
ADD.B Rs,Rd	R:W NEXT								
ADD.W #xx:16,Rd	R:W 2nd	R:W NEXT							
ADD.W Rs,Rd	R:W NEXT								
ADD.L #xx:32,ERd	R:W 2nd	R:W 3rd	R:W NEXT						
ADD.L ERs,ERd	R:W NEXT								
ADDS #1/2/4,ERd	R:W NEXT								
ADDX #xx:8,Rd	R:W NEXT								
ADDX Rs,Rd	R:W NEXT								
AND.B #xx:8,Rd	R:W NEXT								
AND.B Rs,Rd	R:W NEXT								
AND.W #xx:16,Rd	R:W 2nd	R:W NEXT							
AND.W Rs,Rd	R:W NEXT								
AND.L #xx:32,ERd	R:W 2nd	R:W 3rd	R:W NEXT						
AND.L ERs,ERd	R:W 2nd	R:W NEXT							
ANDC #xx:8,CCR	R:W NEXT								
ANDC #xx:8,EXR	R:W 2nd	R:W NEXT							
BAND #xx:3,Rd	R:W NEXT								
BAND #xx:3,@ERd	R:W 2nd	R:B EA	R:W:M NEXT						
BAND #xx:3,@aa:8	R:W 2nd	R:B EA	R:W:M NEXT						
BAND #xx:3,@aa:16	R:W 2nd	R:W 3rd	R:B EA	R:W:M NEXT					
BAND #xx:3,@aa:32	R:W 2nd	R:W 3rd	R:W 4th	R:B EA	R:W:M NEXT				
BRA d:8 (BT d:8)	R:W NEXT	R:W EA							
BRN d:8 (BF d:8)	R:W NEXT	R:W EA							
BHI d:8	R:W NEXT	R:W EA							
BLS d:8	R:W NEXT	R:W EA							
BCC d:8 (BHS d:8)	R:W NEXT	R:W EA							
BCS d:8 (BLO d:8)	R:W NEXT	R:W EA							
BNE d:8	R:W NEXT	R:W EA							
BEQ d:8	R:W NEXT	R:W EA							
BVC d:8	R:W NEXT	R:W EA							
BVS d:8	R:W NEXT	R:W EA							
BPL d:8	R:W NEXT	R:W EA							
BMI d:8	R:W NEXT	R:W EA							
BGE d:8	R:W NEXT	R:W EA							
BLT d:8	R:W NEXT	R:W EA							
BGT d:8	R:W NEXT	R:W EA							

Instruction	1	2	3	4	5	6	7	8	9
BLE d:8	R:W NEXT	R:W EA							
BRA d:16 (BT d:16)	R:W 2nd	Internal operation, 1 state	R:W EA						
BRN d:16 (BF d:16)	R:W 2nd	Internal operation, 1 state	R:W EA						
BHI d:16	R:W 2nd	Internal operation, 1 state	R:W EA						
BLS d:16	R:W 2nd	Internal operation, 1 state	R:W EA						
BCC d:16 (BHS d:16)	R:W 2nd	Internal operation, 1 state	R:W EA						
BCCS d:16 (BLO d:16)	R:W 2nd	Internal operation, 1 state	R:W EA						
BNE d:16	R:W 2nd	Internal operation, 1 state	R:W EA						
BEQ d:16	R:W 2nd	Internal operation, 1 state	R:W EA						
BVC d:16	R:W 2nd	Internal operation, 1 state	R:W EA						
BVS d:16	R:W 2nd	Internal operation, 1 state	R:W EA						
BPL d:16	R:W 2nd	Internal operation, 1 state	R:W EA						
BMI d:16	R:W 2nd	Internal operation, 1 state	R:W EA						
BGE d:16	R:W 2nd	Internal operation, 1 state	R:W EA						
BLT d:16	R:W 2nd	Internal operation, 1 state	R:W EA						
BGT d:16	R:W 2nd	Internal operation, 1 state	R:W EA						
BLE d:16	R:W 2nd	Internal operation, 1 state	R:W EA						
BCLR #xx:3,Rd	R:W NEXT								
BCLR #xx:3,@ERd	R:W 2nd	R:B:M EA	R:W:M NEXT	W:B EA					
BCLR #xx:3,@aa:8	R:W 2nd	R:B:M EA	R:W:M NEXT	W:B EA					
BCLR #xx:3,@aa:16	R:W 2nd	R:W 3rd	R:B:M EA	R:W:M NEXT	W:B EA				

Instruction	1	2	3	4	5	6	7	8	9
BCLR #xx:3,@aa:32	R:W 2nd	R:W 3rd	R:W 4th	R:B:M EA	R:W:M NEXT	W:B EA			
BCLR Rn,Rd	R:W NEXT								
BCLR Rn,@ERd	R:W 2nd	R:B:MEA	R:W:M NEXT	W:B EA					
BCLR Rn,@aa:8	R:W 2nd	R:B:MEA	R:W:M NEXT	W:B EA					
BCLR Rn,@aa:16	R:W 2nd	R:W 3rd	R:B:MEA	R:W:M NEXT	W:B EA				
BCLR Rn,@aa:32	R:W 2nd	R:W 3rd	R:W 4th	R:B:MEA	R:W:M NEXT	W:B EA			
BIAND #xx:3,Rd	R:W NEXT								
BIAND #xx:3,@ERd	R:W 2nd	R:B EA	R:W:M NEXT						
BIAND #xx:3,@aa:8	R:W 2nd	R:B EA	R:W:M NEXT						
BIAND #xx:3,@aa:16	R:W 2nd	R:W 3rd	R:B EA	R:W:M NEXT					
BIAND #xx:3,@aa:32	R:W 2nd	R:W 3rd	R:W 4th	R:B EA	R:W:M NEXT				
BILD #xx:3,Rd	R:W NEXT								
BILD #xx:3,@ERd	R:W 2nd	R:B EA	R:W:M NEXT						
BILD #xx:3,@aa:8	R:W 2nd	R:B EA	R:W:M NEXT						
BILD #xx:3,@aa:16	R:W 2nd	R:W 3rd	R:B EA	R:W:M NEXT					
BILD #xx:3,@aa:32	R:W 2nd	R:W 3rd	R:W 4th	R:B EA	R:W:M NEXT				
BIOR #xx:3,Rd	R:W NEXT								
BIOR #xx:3,@ERd	R:W 2nd	R:B EA	R:W:M NEXT						
BIOR #xx:3,@aa:8	R:W 2nd	R:B EA	R:W:M NEXT						
BIOR #xx:3,@aa:16	R:W 2nd	R:W 3rd	R:B EA	R:W:M NEXT					
BIOR #xx:3,@aa:32	R:W 2nd	R:W 3rd	R:W 4th	R:B EA	R:W:M NEXT				
BIST #xx:3,Rd	R:W NEXT								
BIST #xx:3,@ERd	R:W 2nd	R:B:MEA	R:W:M NEXT	W:B EA					
BIST #xx:3,@aa:8	R:W 2nd	R:B:MEA	R:W:M NEXT	W:B EA					
BIST #xx:3,@aa:16	R:W 2nd	R:W 3rd	R:B:MEA	R:W:M NEXT	W:B EA				
BIST #xx:3,@aa:32	R:W 2nd	R:W 3rd	R:W 4th	R:B:MEA	R:W:M NEXT	W:B EA			
BIXOR #xx:3,Rd	R:W NEXT								
BIXOR #xx:3,@ERd	R:W 2nd	R:B EA	R:W:M NEXT						
BIXOR #xx:3,@aa:8	R:W 2nd	R:B EA	R:W:M NEXT						
BIXOR #xx:3,@aa:16	R:W 2nd	R:W 3rd	R:B EA	R:W:M NEXT					
BIXOR #xx:3,@aa:32	R:W 2nd	R:W 3rd	R:W 4th	R:B EA	R:W:M NEXT				
BLD #xx:3,Rd	R:W NEXT								
BLD #xx:3,@ERd	R:W 2nd	R:B EA	R:W:M NEXT						
BLD #xx:3,@aa:8	R:W 2nd	R:B EA	R:W:M NEXT						
BLD #xx:3,@aa:16	R:W 2nd	R:W 3rd	R:B EA	R:W:M NEXT					
BLD #xx:3,@aa:32	R:W 2nd	R:W 3rd	R:W 4th	R:B EA	R:W:M NEXT				
BNOT #xx:3,Rd	R:W NEXT								

Instruction	1	2	3	4	5	6	7	8	9
BNOT #xx:3,@ERd	R:W 2nd	R:B:M EA	R:W:M NEXT	W:B EA					
BNOT #xx:3,@aa:8	R:W 2nd	R:B:M EA	R:W:M NEXT	W:B EA					
BNOT #xx:3,@aa:16	R:W 2nd	R:W 3rd	R:B:M EA	R:W:M NEXT	W:B EA				
BNOT #xx:3,@aa:32	R:W 2nd	R:W 3rd	R:W 4th	R:B:M EA	R:W:M NEXT	W:B EA			
BNOT Rn,Rd	R:W NEXT								
BNOT Rn,@ERd	R:W 2nd	R:B:M EA	R:W:M NEXT	W:B EA					
BNOT Rn,@aa:8	R:W 2nd	R:B:M EA	R:W:M NEXT	W:B EA					
BNOT Rn,@aa:16	R:W 2nd	R:W 3rd	R:B:M EA	R:W:M NEXT	W:B EA				
BNOT Rn,@aa:32	R:W 2nd	R:W 3rd	R:W 4th	R:B:M EA	R:W:M NEXT	W:B EA			
BOR #xx:3,Rd	R:W NEXT								
BOR #xx:3,@ERd	R:W 2nd	R:B EA	R:W:M NEXT						
BOR #xx:3,@aa:8	R:W 2nd	R:B EA	R:W:M NEXT						
BOR #xx:3,@aa:16	R:W 2nd	R:W 3rd	R:B EA	R:W:M NEXT					
BOR #xx:3,@aa:32	R:W 2nd	R:W 3rd	R:W 4th	R:B EA	R:W:M NEXT				
BSET #xx:3,Rd	R:W NEXT								
BSET #xx:3,@ERd	R:W 2nd	R:B:M EA	R:W:M NEXT	W:B EA					
BSET #xx:3,@aa:8	R:W 2nd	R:B:M EA	R:W:M NEXT	W:B EA					
BSET #xx:3,@aa:16	R:W 2nd	R:W 3rd	R:B:M EA	R:W:M NEXT	W:B EA				
BSET #xx:3,@aa:32	R:W 2nd	R:W 3rd	R:W 4th	R:B:M EA	R:W:M NEXT	W:B EA			
BSET Rn,Rd	R:W NEXT								
BSET Rn,@ERd	R:W 2nd	R:B:M EA	R:W:M NEXT	W:B EA					
BSET Rn,@aa:8	R:W 2nd	R:B:M EA	R:W:M NEXT	W:B EA					
BSET Rn,@aa:16	R:W 2nd	R:W 3rd	R:B:M EA	R:W:M NEXT	W:B EA				
BSET Rn,@aa:32	R:W 2nd	R:W 3rd	R:W 4th	R:B:M EA	R:W:M NEXT	W:B EA			
BSR d:8	R:W NEXT	R:W EA	W:W:M stack (H)	W:W stack (L)					
BSR d:16	R:W 2nd	Internal operation, 1 state	R:W EA	W:W:M stack (H)	W:W stack (L)				
BST #xx:3,Rd	R:W NEXT								
BST #xx:3,@ERd	R:W 2nd	R:B:M EA	R:W:M NEXT	W:B EA					
BST #xx:3,@aa:8	R:W 2nd	R:B:M EA	R:W:M NEXT	W:B EA					
BST #xx:3,@aa:16	R:W 2nd	R:W 3rd	R:B:M EA	R:W:M NEXT	W:B EA				
BST #xx:3,@aa:32	R:W 2nd	R:W 3rd	R:W 4th	R:B:M EA	R:W:M NEXT	W:B EA			
BTST #xx:3,Rd	R:W NEXT								
BTST #xx:3,@ERd	R:W 2nd	R:B EA	R:W:M NEXT						

Instruction	1	2	3	4	5	6	7	8	9
BTST #xx:3,@aa:8	R:W 2nd	R:B EA	R:W:M NEXT						
BTST #xx:3,@aa:16	R:W 2nd	R:W 3rd	R:B EA	R:W:M NEXT					
BTST #xx:3,@aa:32	R:W 2nd	R:W 3rd	R:W 4th	R:B EA	R:W:M NEXT				
BTST Rn,Rd	R:W NEXT								
BTST Rn,@ERd	R:W 2nd	R:B EA	R:W:M NEXT						
BTST Rn,@aa:8	R:W 2nd	R:B EA	R:W:M NEXT						
BTST Rn,@aa:16	R:W 2nd	R:W 3rd	R:B EA	R:W:M NEXT					
BTST Rn,@aa:32	R:W 2nd	R:W 3rd	R:W 4th	R:B EA	R:W:M NEXT				
BXOR #xx:3,Rd	R:W NEXT								
BXOR #xx:3,@ERd	R:W 2nd	R:B EA	R:W:M NEXT						
BXOR #xx:3,@aa:8	R:W 2nd	R:B EA	R:W:M NEXT						
BXOR #xx:3,@aa:16	R:W 2nd	R:W 3rd	R:B EA	R:W:M NEXT					
BXOR #xx:3,@aa:32	R:W 2nd	R:W 3rd	R:W 4th	R:B EA	R:W:M NEXT				
CLRMAC	R:W NEXT	Internal operation, 1 state							
CMP.B #xx:8,Rd	R:W NEXT								
CMP.B Rs,Rd	R:W NEXT								
CMP.W #xx:16,Rd	R:W 2nd	R:W NEXT							
CMP.W Rs,Rd	R:W NEXT								
CMP.L #xx:32,ERd	R:W 2nd	R:W 3rd	R:W NEXT						
CMP.L ERs,ERd	R:W NEXT								
DAA Rd	R:W NEXT								
DAS Rd	R:W NEXT								
DEC.B Rd	R:W NEXT								
DEC.W #1/2,Rd	R:W NEXT								
DEC.L #1/2,ERd	R:W NEXT								
DIVXS.B Rs,Rd	R:W 2nd	R:W NEXT	Internal operation, 11 states						
DIVXS.W Rs,ERd	R:W 2nd	R:W NEXT	Internal operation, 19 states						
DIVXU.B Rs,Rd	R:W NEXT	Internal operation, 11 states							
DIVXU.W Rs,ERd	R:W NEXT	Internal operation, 19 states							
EEMOV.B	R:W 2nd	R:B EAs*1	R:B EAd*1	R:B EAs*2	W:B EAd*2	R:W NEXT			
EEMOV.W	R:W 2nd	R:B EAs*1	R:B EAd*1	R:B EAs*2	W:B EAd*2	R:W NEXT			
EXTS.W Rd	R:W NEXT			← Repeated n times*2 →					
EXTS.L ERd	R:W NEXT								
EXTU.W Rd	R:W NEXT								
EXTU.L ERd	R:W NEXT								
INC.B Rd	R:W NEXT								



Instruction	1	2	3	4	5	6	7	8	9
INC.W #1/2,Rd	R:W NEXT								
INC.L #1/2,ERd	R:W NEXT								
JMP @ERn	R:W NEXT	R:W EA							
JMP @aa:24	Internal operation, 1 state	Internal operation, 1 state	R:W EA						
JMP @aa:8	R:W NEXT	R:W:M aa:8	R:W aa:8	Internal operation, 1 state	R:W EA				
JSR @ERn	R:W NEXT	R:W EA	W:W:M stack (H)	W:W stack (L)					
JSR @aa:24	R:W 2nd	Internal operation, 1 state	R:W EA	W:W:M stack (H)	W:W stack (L)				
JSR @aa:8	R:W NEXT	R:W:M aa:8	R:W aa:8	W:W:M stack (H)	W:W stack (L)	R:W EA			
LDC #xx:8,CCR	R:W NEXT	R:W NEXT							
LDC #xx:8,EXR	R:W 2nd	R:W NEXT							
LDC Rs,CCR	R:W NEXT								
LDC Rs,EXR	R:W NEXT								
LDC @ERs,CCR	R:W 2nd	R:W NEXT	R:W EA						
LDC @ERs,EXR	R:W 2nd	R:W NEXT	R:W EA						
LDC @(d:16,ERs),CCR	R:W 2nd	R:W 3rd	R:W NEXT	R:W EA					
LDC @(d:16,ERs),EXR	R:W 2nd	R:W 3rd	R:W NEXT	R:W EA					
LDC @(d:32,ERs),CCR	R:W 2nd	R:W 3rd	R:W 4th	R:W 5th	R:W NEXT	R:W EA			
LDC @(d:32,ERs),EXR	R:W 2nd	R:W 3rd	R:W 4th	R:W 5th	R:W NEXT	R:W EA			
LDC @ERs+,CCR	R:W 2nd	R:W NEXT	Internal operation, 1 state	R:W EA					
LDC @ERs+,EXR	R:W 2nd	R:W NEXT	Internal operation, 1 state	R:W EA					
LDC @aa:16,CCR	R:W 2nd	R:W 3rd	R:W NEXT	R:W EA					
LDC @aa:16,EXR	R:W 2nd	R:W 3rd	R:W NEXT	R:W EA					
LDC @aa:32,CCR	R:W 2nd	R:W 3rd	R:W 4th	R:W NEXT	R:W EA				
LDC @aa:32,EXR	R:W 2nd	R:W 3rd	R:W 4th	R:W NEXT	R:W EA				
LDM.L @SP+, (ERn-ERn+1)	R:W 2nd	R:W:M NEXT	Internal operation, 1 state	R:W:M stack (H)*3	R:W stack (L)*3				
LDM.L @SP+,(ERn-ERn+2)	R:W 2nd	R:W NEXT	Internal operation, 1 state	R:W:M stack (H)*3	R:W stack (L)*3				
LDM.L @SP+,(ERn-ERn+3)	R:W 2nd	R:W NEXT	Internal operation, 1 state	R:W:M stack (H)*3	R:W stack (L)*3				
LDMAC ERs,MACH	R:W NEXT	Internal operation, 1 state	Internal operation, 1 state	Internal operation, 1 state	Internal operation, 1 state				

Instruction	1	2	3	4	5	6	7	8	9
LDMAC ERs,MACL	R:W NEXT	Internal operation, 1 state							
MAC @ERn+, @ERm+	R:W 2nd	R:W NEXT	R:W EAh	R:W EAm					
MOV.B #xx:8,Rd	R:W NEXT								
MOV.B Rs,Rd	R:W NEXT								
MOV.B @ERs,Rd	R:W NEXT	R:B EA							
MOV.B @(d:16,ERs),Rd	R:W 2nd	R:W NEXT	R:B EA						
MOV.B @(d:32,ERs),Rd	R:W 2nd	R:W 3rd	R:W 4th	R:W NEXT	R:B EA				
MOV.B @ERs+,Rd	R:W NEXT	Internal operation, 1 state	R:B EA						
MOV.B @aa:8,Rd	R:W NEXT	R:B EA							
MOV.B @aa:16,Rd	R:W 2nd	R:W NEXT	R:B EA						
MOV.B @aa:32,Rd	R:W 2nd	R:W 3rd	R:W NEXT	R:B EA					
MOV.B Rs,@ERd	R:W NEXT	W:B EA							
MOV.B Rs @(d:16,ERd)	R:W 2nd	R:W NEXT	W:B EA						
MOV.B Rs @(d:32,ERd)	R:W 2nd	R:W 3rd	R:W 4th	R:W NEXT	W:B EA				
MOV.B Rs,@-ERd	R:W NEXT	Internal operation, 1 state	W:B EA						
MOV.B Rs,@aa:8	R:W NEXT	W:B EA							
MOV.B Rs,@aa:16	R:W 2nd	R:W NEXT	W:B EA						
MOV.B Rs,@aa:32	R:W 2nd	R:W 3rd	R:W NEXT	W:B EA					
MOV.W #xx:16,Rd	R:W 2nd	R:W NEXT							
MOV.W Rs,Rd	R:W NEXT								
MOV.W @ERs,Rd	R:W NEXT	R:W EA							
MOV.W @(d:16,ERs),Rd	R:W 2nd	R:W NEXT	R:W EA						
MOV.W @(d:32,ERs),Rd	R:W 2nd	R:W 3rd	R:W 4th	R:W NEXT	R:W EA				
MOV.W @ERs+,Rd	R:W NEXT	Internal operation, 1 state	R:W EA						
MOV.W @aa:16,Rd	R:W 2nd	R:W NEXT	R:W EA						
MOV.W @aa:32,Rd	R:W 2nd	R:W 3rd	R:W NEXT	R:B EA					
MOV.W Rs,@ERd	R:W NEXT	W:W EA							
MOV.W Rs,@(d:16,ERd)	R:W 2nd	R:W NEXT	W:W EA						
MOV.W Rs,@(d:32,ERd)	R:W 2nd	R:W 3rd	R:W 4th	R:W NEXT	W:W EA				
MOV.W Rs,@-ERd	R:W NEXT	Internal operation, 1 state	W:W EA						
MOV.W Rs,@aa:16	R:W 2nd	R:W NEXT	W:W EA						
MOV.W Rs,@aa:32	R:W 2nd	R:W 3rd	R:W NEXT	W:W EA					

Instruction	1	2	3	4	5	6	7	8	9
MOV.L #xx:32,ERd	R:W 2nd	R:W 3rd	R:W NEXT						
MOV.L ERs,ERd	R:W NEXT								
MOV.L @ERs,ERd	R:W 2nd	R:W:M NEXT	R:W:M EA	R:W EA+2					
MOV.L @(d:16,ERs),ERd	R:W 2nd	R:W:M 3rd	R:W NEXT	R:W:M EA	R:W EA+2				
MOV.L @(d:32,ERs),ERd	R:W 2nd	R:W:M 3rd	R:W:M 4th	R:W 5th	R:W NEXT	R:W:M EA	R:W EA+2		
MOV.L @ERs+,ERd	R:W 2nd	R:W:M NEXT	Internal operation, 1 state	R:W:M EA	R:W EA+2				
MOV.L @aa:16,ERd	R:W 2nd	R:W:M 3rd	R:W NEXT	R:W:M EA	R:W EA+2				
MOV.L @aa:32,ERd	R:W 2nd	R:W:M 3rd	R:W 4th	R:W NEXT	R:W:M EA	R:W EA+2			
MOV.L ERs,@ERd	R:W 2nd	R:W:M NEXT	W:W:M EA	W:W EA+2					
MOV.L ERs,@(d:16,ERd)	R:W 2nd	R:W:M 3rd	R:W NEXT	W:W:M EA	W:W EA+2				
MOV.L ERs,@(d:32,ERd)	R:W 2nd	R:W:M 3rd	R:W:M 4th	R:W 5th	R:W NEXT	W:W:M EA	W:W EA+2		
MOV.L ERs,@-ERd	R:W 2nd	R:W:M NEXT	Internal operation, 1 state	W:W:M EA	W:W EA+2				
MOV.L ERs,@aa:16	R:W 2nd	R:W:M 3rd	R:W NEXT	W:W:M EA	W:W EA+2				
MOV.L ERs,@aa:32	R:W 2nd	R:W:M 3rd	R:W 4th	R:W NEXT	W:W:M EA	W:W EA+2			
MOV.FPE @aa:16,Rd	Cannot be used in the H8S/2633 Series								
MOV.TPE Rs,@aa:16									
MULX.SB Rs,Rd	R:W 2nd	R:W NEXT	Internal operation, 2 states						
MULX.S.W Rs,ERd	R:W 2nd	R:W NEXT	Internal operation, 3 states						
MULXUB Rs,Rd	R:W NEXT	Internal operation, 2 states							
MULX.UW Rs,ERd	R:W NEXT	Internal operation, 3 states							
NEG.B Rd	R:W NEXT								
NEG.W Rd	R:W NEXT								
NEG.L ERd	R:W NEXT								
NOP	R:W NEXT								
NOT.B Rd	R:W NEXT								
NOT.W Rd	R:W NEXT								
NOT.L ERd	R:W NEXT								
OR.B #xx:8,Rd	R:W NEXT								
OR.B Rs,Rd	R:W NEXT								
OR.W #xx:16,Rd	R:W 2nd	R:W NEXT							
OR.W Rs,Rd	R:W NEXT								
OR.L #xx:32,ERd	R:W 2nd	R:W 3rd	R:W NEXT						
OR.L ERs,ERd	R:W 2nd	R:W NEXT							
ORC #xx:8,CCR	R:W NEXT								
ORC #xx:8,EXR	R:W 2nd	R:W NEXT							

Instruction	1	2	3	4	5	6	7	8	9
POP.W Rn	R:W NEXT	Internal operation, 1 state	R:W EA						
POP.L ERn	R:W 2nd	R:W:M NEXT	Internal operation, 1 state W:W EA	R:W:M EA	R:W EA+2				
PUSH.W Rn	R:W NEXT	Internal operation, 1 state	W:W EA						
PUSH.L ERn	R:W 2nd	R:W:M NEXT	Internal operation, 1 state	W:W:M EA	W:W EA+2				
ROTL.B Rd	R:W NEXT								
ROTL.B #2,Rd	R:W NEXT								
ROTL.W Rd	R:W NEXT								
ROTL.W #2,Rd	R:W NEXT								
ROTL.L ERd	R:W NEXT								
ROTL.L #2,ERd	R:W NEXT								
ROTR.B Rd	R:W NEXT								
ROTR.B #2,Rd	R:W NEXT								
ROTR.W Rd	R:W NEXT								
ROTR.W #2,Rd	R:W NEXT								
ROTR.L ERd	R:W NEXT								
ROTR.L #2,ERd	R:W NEXT								
ROTXL.B Rd	R:W NEXT								
ROTXL.B #2,Rd	R:W NEXT								
ROTXL.W Rd	R:W NEXT								
ROTXL.W #2,Rd	R:W NEXT								
ROTXL.L ERd	R:W NEXT								
ROTXL.L #2,ERd	R:W NEXT								
ROTXR.B Rd	R:W NEXT								
ROTXR.B #2,Rd	R:W NEXT								
ROTXR.W Rd	R:W NEXT								
ROTXR.W #2,Rd	R:W NEXT								
ROTXR.L ERd	R:W NEXT								
ROTXR.L #2,ERd	R:W NEXT								
RTE	R:W NEXT	R:W stack (EXR)	R:W stack (H)	R:W stack (L)	Internal operation, 1 state	R:W <sup>#4</sup>			
RTS	R:W NEXT	R:W:M stack (H)	R:W stack (L)	Internal operation, 1 state	R:W <sup>#4</sup>				
SHAL.B Rd	R:W NEXT								

Instruction	1	2	3	4	5	6	7	8	9
SHAL.B #2,Rd	R:W NEXT								
SHAL.W Rd	R:W NEXT								
SHAL.W #2,Rd	R:W NEXT								
SHAL.L ERd	R:W NEXT								
SHAL.L #2,ERd	R:W NEXT								
SHAR.B Rd	R:W NEXT								
SHAR.B #2,Rd	R:W NEXT								
SHAR.W Rd	R:W NEXT								
SHAR.W #2,Rd	R:W NEXT								
SHAR.L ERd	R:W NEXT								
SHAR.L #2,ERd	R:W NEXT								
SHLL.B Rd	R:W NEXT								
SHLL.B #2,Rd	R:W NEXT								
SHLL.W Rd	R:W NEXT								
SHLL.W #2,Rd	R:W NEXT								
SHLL.L ERd	R:W NEXT								
SHLL.L #2,ERd	R:W NEXT								
SHLR.B Rd	R:W NEXT								
SHLR.B #2,Rd	R:W NEXT								
SHLR.W Rd	R:W NEXT								
SHLR.W #2,Rd	R:W NEXT								
SHLR.L ERd	R:W NEXT								
SHLR.L #2,ERd	R:W NEXT								
SLEEP	R:W NEXT	Internal operation:W							
STC CCR, Rd	R:W NEXT								
STC EXR, Rd	R:W NEXT								
STC CCR, @ERd	R:W 2nd	R:W NEXT	W:W EA						
STC EXR, @ERd	R:W 2nd	R:W NEXT	W:W EA						
STC CCR, @(d:16,ERd)	R:W 2nd	R:W 3rd	R:W NEXT	W:W EA					
STC EXR, @(d:16,ERd)	R:W 2nd	R:W 3rd	R:W NEXT	W:W EA					
STC CCR, @(d:32,ERd)	R:W 2nd	R:W 3rd	R:W 4th	R:W 5th	R:W NEXT	W:W EA			
STC EXR, @(d:32,ERd)	R:W 2nd	R:W 3rd	R:W 4th	R:W 5th	R:W NEXT	W:W EA			
STC CCR, @-ERd	R:W 2nd	R:W NEXT	Internal operation, 1 state	W:W EA					
STC EXR, @-ERd	R:W 2nd	R:W NEXT	Internal operation, 1 state	W:W EA					
STC CCR, @aa:16	R:W 2nd	R:W 3rd	R:W NEXT	W:W EA					
STC EXR, @aa:16	R:W 2nd	R:W 3rd	R:W NEXT	W:W EA					

Instruction	1	2	3	4	5	6	7	8	9
STC CCR, @aa:32	R:W 2nd	R:W 3rd	R:W 4th	R:W NEXT	W:W EA				
STC EXR, @aa:32	R:W 2nd	R:W 3rd	R:W 4th	R:W NEXT	W:W EA				
STM.L(ERn-ERn+1), @-SP	R:W 2nd	R:W:M NEXT	Internal operation, 1 state	W:W:M stack (H) *3	W:W stack (L) *3				
STM.L(ERn-ERn+2), @-SP	R:W 2nd	R:W:M NEXT	Internal operation, 1 state	W:W:M stack (H) *3	W:W stack (L) *3				
STM.L(ERn-ERn+3), @-SP	R:W 2nd	R:W:M NEXT	Internal operation, 1 state	W:W:M stack (H) *3	W:W stack (L) *3				
STMACH, ERd	R:W NEXT								
STMACL, ERd	R:W NEXT								
SUB.B Rs, Rd	R:W NEXT								
SUB.W #xx:16, Rd	R:W 2nd	R:W NEXT							
SUB.W Rs, Rd	R:W NEXT								
SUB.L #xx:32, ERd	R:W 2nd	R:W 3rd	R:W NEXT						
SUB.L ERs, ERd	R:W NEXT								
SUBS #1/2/4, ERd	R:W NEXT								
SUBX #xx:8, Rd	R:W NEXT								
SUBX Rs, Rd	R:W NEXT								
TAS @ERd*8	R:W 2nd	R:W NEXT	R:B:M EA	W:B EA					
TRAPA #x:2	R:W NEXT	Internal operation, 1 state	W:W stack (L)	W:W stack (H)	W:W stack (EXR)	R:W:M VEC	R:W VEC+2	Internal operation, 1 state	R:W*7
XOR.B #xx8, Rd	R:W NEXT								
XOR.B Rs, Rd	R:W NEXT								
XOR.W #xx:16, Rd	R:W 2nd	R:W NEXT							
XOR.W Rs, Rd	R:W NEXT								
XOR.L #xx:32, ERd	R:W 2nd	R:W 3rd	R:W NEXT						
XOR.L ERs, ERd	R:W 2nd	R:W NEXT							
XORC #xx:8, CCR	R:W NEXT								
XORC #xx:8, EXR	R:W 2nd	R:W NEXT							

Instruction	1	2	3	4	5	6	7	8	9
Reset exception handling	R:W VEC	R:W VEC+2	Internal operation, 1 state	R:W <sup>#5</sup>					
Interrupt exception handling	R:W <sup>#6</sup>	Internal operation, 1 state	W:W stack (L)	W:W stack (H)	W:W stack (EXR)	R:W:W VEC	R:W VEC+2	Internal operation, 1 state	R:W <sup>#7</sup>

Notes: \*1 EAs is the contents of ER5. EAd is the contents of ER6.

\*2 EAs is the contents of ER5. EAd is the contents of ER6. Both registers are incremented by 1 after execution of the instruction. n is the initial value of R4L or R4. If n = 0, these bus cycles are not executed.

\*3 Repeated two times to save or restore two registers, three times for three registers, or four times for four registers.

\*4 Start address after return.

\*5 Start address of the program.

\*6 Prefetch address, equal to two plus the PC value pushed onto the stack. In recovery from sleep mode or software standby mode the read operation is replaced by an internal operation.

\*7 Start address of the interrupt-handling routine.

\*8 When using the TAS instruction, use register ER0, ER1, ER4, or ER5.

## A.6 Condition Code Modification

This section indicates the effect of each CPU instruction on the condition code. The notation used in the table is defined below.

$m =$	$\left\{ \begin{array}{l} 31 \text{ for longword operands} \\ 15 \text{ for word operands} \\ 7 \text{ for byte operands} \end{array} \right.$
$S_i$	The $i$ -th bit of the source operand
$D_i$	The $i$ -th bit of the destination operand
$R_i$	The $i$ -th bit of the result
$D_n$	The specified bit in the destination operand
—	Not affected
$\updownarrow$	Modified according to the result of the instruction (see definition)
0	Always cleared to 0
1	Always set to 1
*	Undetermined (no guaranteed value)
$Z'$	Z flag before instruction execution
$C'$	C flag before instruction execution



**Table A-7 Condition Code Modification**

Instruction	H	N	Z	V	C	Definition
ADD	↑	↑	↑	↑	↑	$H = S_{m-4} \cdot D_{m-4} + D_{m-4} \cdot \overline{R_{m-4}} + S_{m-4} \cdot \overline{R_{m-4}}$ $N = R_m$ $Z = \overline{R_m} \cdot \overline{R_{m-1}} \cdot \dots \cdot \overline{R_0}$ $V = S_m \cdot D_m \cdot \overline{R_m} + \overline{S_m} \cdot \overline{D_m} \cdot R_m$ $C = S_m \cdot D_m + D_m \cdot \overline{R_m} + S_m \cdot \overline{R_m}$
ADDS	—	—	—	—	—	
ADDX	↑	↑	↑	↑	↑	$H = S_{m-4} \cdot D_{m-4} + D_{m-4} \cdot \overline{R_{m-4}} + S_{m-4} \cdot \overline{R_{m-4}}$ $N = R_m$ $Z = Z' \cdot \overline{R_m} \cdot \dots \cdot \overline{R_0}$ $V = S_m \cdot D_m \cdot \overline{R_m} + \overline{S_m} \cdot \overline{D_m} \cdot R_m$ $C = S_m \cdot D_m + D_m \cdot \overline{R_m} + S_m \cdot \overline{R_m}$
AND	—	↑	↑	0	—	$N = R_m$ $Z = \overline{R_m} \cdot \overline{R_{m-1}} \cdot \dots \cdot \overline{R_0}$
ANDC	↑	↑	↑	↑	↑	Stores the corresponding bits of the result. No flags change when the operand is EXR.
BAND	—	—	—	—	↑	$C = C' \cdot D_n$
Bcc	—	—	—	—	—	
BCLR	—	—	—	—	—	
BIAND	—	—	—	—	↑	$C = C' \cdot \overline{D_n}$
BILD	—	—	—	—	↑	$C = \overline{D_n}$
BIOR	—	—	—	—	↑	$C = C' + \overline{D_n}$
BIST	—	—	—	—	—	
BIXOR	—	—	—	—	↑	$C = C' \cdot D_n + \overline{C'} \cdot \overline{D_n}$
BLD	—	—	—	—	↑	$C = D_n$
BNOT	—	—	—	—	—	
BOR	—	—	—	—	↑	$C = C' + D_n$
BSET	—	—	—	—	—	
BSR	—	—	—	—	—	
BST	—	—	—	—	—	
BTST	—	—	↑	—	—	$Z = \overline{D_n}$
BXOR	—	—	—	—	↑	$C = C' \cdot \overline{D_n} + \overline{C'} \cdot D_n$
CLRMAC	—	—	—	—	—	

Instruction	H	N	Z	V	C	Definition
CMP	↑	↑	↑	↑	↑	$H = \overline{S_{m-4}} \cdot \overline{D_{m-4}} + \overline{D_{m-4}} \cdot R_{m-4} + S_{m-4} \cdot R_{m-4}$ $N = R_m$ $Z = \overline{R_m} \cdot \overline{R_{m-1}} \cdot \dots \cdot \overline{R_0}$ $V = \overline{S_m} \cdot D_m \cdot \overline{R_m} + S_m \cdot \overline{D_m} \cdot R_m$ $C = S_m \cdot \overline{D_m} + \overline{D_m} \cdot R_m + S_m \cdot R_m$
DAA	*	↑	↑	*	↑	$N = R_m$ $Z = \overline{R_m} \cdot \overline{R_{m-1}} \cdot \dots \cdot \overline{R_0}$ C: decimal arithmetic carry
DAS	*	↑	↑	*	↑	$N = R_m$ $Z = \overline{R_m} \cdot \overline{R_{m-1}} \cdot \dots \cdot \overline{R_0}$ C: decimal arithmetic borrow
DEC	—	↑	↑	↑	—	$N = R_m$ $Z = \overline{R_m} \cdot \overline{R_{m-1}} \cdot \dots \cdot \overline{R_0}$ $V = D_m \cdot \overline{R_m}$
DIVXS	—	↑	↑	—	—	$N = S_m \cdot \overline{D_m} + \overline{S_m} \cdot D_m$ $Z = \overline{S_m} \cdot \overline{S_{m-1}} \cdot \dots \cdot \overline{S_0}$
DIVXU	—	↑	↑	—	—	$N = S_m$ $Z = \overline{S_m} \cdot \overline{S_{m-1}} \cdot \dots \cdot \overline{S_0}$
EEPMOV	—	—	—	—	—	
EXTS	—	↑	↑	0	—	$N = R_m$ $Z = \overline{R_m} \cdot \overline{R_{m-1}} \cdot \dots \cdot \overline{R_0}$
EXTU	—	0	↑	0	—	$Z = \overline{R_m} \cdot \overline{R_{m-1}} \cdot \dots \cdot \overline{R_0}$
INC	—	↑	↑	↑	—	$N = R_m$ $Z = \overline{R_m} \cdot \overline{R_{m-1}} \cdot \dots \cdot \overline{R_0}$ $V = \overline{D_m} \cdot R_m$
JMP	—	—	—	—	—	
JSR	—	—	—	—	—	
LDC	↑	↑	↑	↑	↑	Stores the corresponding bits of the result. No flags change when the operand is EXR.
LDM	—	—	—	—	—	
LDMAC	—	—	—	—	—	
MAC	—	—	—	—	—	

Instruction	H	N	Z	V	C	Definition
MOV	—	↓	↓	0	—	$N = R_m$ $Z = \overline{R_m} \cdot \overline{R_{m-1}} \cdot \dots \cdot \overline{R_0}$
MOVFPPE						Can not be used in H8S/2633 Series
MOVTPE						
MULXS	—	↓	↓	—	—	$N = R_{2m}$ $Z = \overline{R_{2m}} \cdot \overline{R_{2m-1}} \cdot \dots \cdot \overline{R_0}$
MULXU	—	—	—	—	—	
NEG	↓	↓	↓	↓	↓	$H = D_{m-4} + R_{m-4}$ $N = R_m$ $Z = \overline{R_m} \cdot \overline{R_{m-1}} \cdot \dots \cdot \overline{R_0}$ $V = D_m \cdot R_m$ $C = D_m + R_m$
NOP	—	—	—	—	—	
NOT	—	↓	↓	0	—	$N = R_m$ $Z = \overline{R_m} \cdot \overline{R_{m-1}} \cdot \dots \cdot \overline{R_0}$
OR	—	↓	↓	0	—	$N = R_m$ $Z = \overline{R_m} \cdot \overline{R_{m-1}} \cdot \dots \cdot \overline{R_0}$
ORC	↓	↓	↓	↓	↓	Stores the corresponding bits of the result. No flags change when the operand is EXR.
POP	—	↓	↓	0	—	$N = R_m$ $Z = \overline{R_m} \cdot \overline{R_{m-1}} \cdot \dots \cdot \overline{R_0}$
PUSH	—	↓	↓	0	—	$N = R_m$ $Z = \overline{R_m} \cdot \overline{R_{m-1}} \cdot \dots \cdot \overline{R_0}$
ROTL	—	↓	↓	0	↓	$N = R_m$ $Z = \overline{R_m} \cdot \overline{R_{m-1}} \cdot \dots \cdot \overline{R_0}$ $C = D_m$ (1-bit shift) or $C = D_{m-1}$ (2-bit shift)
ROTR	—	↓	↓	0	↓	$N = R_m$ $Z = \overline{R_m} \cdot \overline{R_{m-1}} \cdot \dots \cdot \overline{R_0}$ $C = D_0$ (1-bit shift) or $C = D_1$ (2-bit shift)

Instruction	H	N	Z	V	C	Definition
ROTXL	—	↓	↓	0	↓	N = Rm $Z = \overline{Rm} \cdot \overline{Rm-1} \cdot \dots \cdot \overline{R0}$ C = Dm (1-bit shift) or C = Dm-1 (2-bit shift)
ROTXR	—	↓	↓	0	↓	N = Rm $Z = \overline{Rm} \cdot \overline{Rm-1} \cdot \dots \cdot \overline{R0}$ C = D0 (1-bit shift) or C = D1 (2-bit shift)
RTE	↓	↓	↓	↓	↓	Stores the corresponding bits of the result.
RTS	—	—	—	—	—	
SHAL	—	↓	↓	↓	↓	N = Rm $Z = \overline{Rm} \cdot \overline{Rm-1} \cdot \dots \cdot \overline{R0}$ $V = \overline{Dm} \cdot Dm-1 + \overline{Dm} \cdot \overline{Dm-1}$ (1-bit shift) $V = \overline{Dm} \cdot Dm-1 \cdot Dm-2 \cdot \overline{Dm} \cdot \overline{Dm-1} \cdot \overline{Dm-2}$ (2-bit shift) C = Dm (1-bit shift) or C = Dm-1 (2-bit shift)
SHAR	—	↓	↓	0	↓	N = Rm $Z = \overline{Rm} \cdot \overline{Rm-1} \cdot \dots \cdot \overline{R0}$ C = D0 (1-bit shift) or C = D1 (2-bit shift)
SHLL	—	↓	↓	0	↓	N = Rm $Z = \overline{Rm} \cdot \overline{Rm-1} \cdot \dots \cdot \overline{R0}$ C = Dm (1-bit shift) or C = Dm-1 (2-bit shift)
SHLR	—	0	↓	0	↓	N = Rm $Z = \overline{Rm} \cdot \overline{Rm-1} \cdot \dots \cdot \overline{R0}$ C = D0 (1-bit shift) or C = D1 (2-bit shift)
SLEEP	—	—	—	—	—	
STC	—	—	—	—	—	
STM	—	—	—	—	—	
STMAC	—	↓	↓	↓	—	N = 1 if MAC instruction resulted in negative value in MAC register Z = 1 if MAC instruction resulted in zero value in MAC register V = 1 if MAC instruction resulted in overflow

Instruction	H	N	Z	V	C	Definition
SUB	↓	↓	↓	↓	↓	$H = S_{m-4} \cdot \overline{D_{m-4}} + \overline{D_{m-4}} \cdot R_{m-4} + S_{m-4} \cdot R_{m-4}$ $N = R_m$ $Z = \overline{R_m} \cdot \overline{R_{m-1}} \cdot \dots \cdot \overline{R_0}$ $V = \overline{S_m} \cdot D_m \cdot \overline{R_m} + S_m \cdot \overline{D_m} \cdot R_m$ $C = S_m \cdot \overline{D_m} + \overline{D_m} \cdot R_m + S_m \cdot R_m$
SUBS	—	—	—	—	—	
SUBX	↓	↓	↓	↓	↓	$H = S_{m-4} \cdot \overline{D_{m-4}} + \overline{D_{m-4}} \cdot R_{m-4} + S_{m-4} \cdot R_{m-4}$ $N = R_m$ $Z = Z' \cdot \overline{R_m} \cdot \dots \cdot \overline{R_0}$ $V = \overline{S_m} \cdot D_m \cdot \overline{R_m} + S_m \cdot \overline{D_m} \cdot R_m$ $C = S_m \cdot \overline{D_m} + \overline{D_m} \cdot R_m + S_m \cdot R_m$
TAS*	—	↓	↓	0	—	$N = D_m$ $Z = \overline{D_m} \cdot \overline{D_{m-1}} \cdot \dots \cdot \overline{D_0}$
TRAPA	—	—	—	—	—	
XOR	—	↓	↓	0	—	$N = R_m$ $Z = \overline{R_m} \cdot \overline{R_{m-1}} \cdot \dots \cdot \overline{R_0}$
XORC	↓	↓	↓	↓	↓	Stores the corresponding bits of the result. No flags change when the operand is EXR.

Note: \* This instruction should be used with the ER0, ER1, ER4, or ER5 general register only.

## Appendix B Internal I/O Register

### B.1A Addresses (H8S/2633 Series, H8S/2633F, H8S/2633R)

Register										Module	Data Bus
Address	Name	Bit 7	Bit 6	Bit 5	Bit 4	Bit 3	Bit 2	Bit 1	Bit 0	Name	Width (bits)
H'FDAC	DADR2									D/A2,	8
H'FDAD	DADR3									D/A3	
H'FDAE	DACR23	DAOE1	DAOE0	DAE	—	—	—	—	—		
H'FDB0	IrCR	IrE	IrCKS2	IrCKS1	IrCKS0	—	—	—	—	SCI0, IrDA	8
H'FDB4	SCRX	—	IICX1	IICX0	IICE	FLSHE	—	—	—	IIC	8
H'FDB5	DDCSWR	SWE	SW	IE	IF	CLR3	CLR2	CLR1	CLR0	IIC	8
H'FDB8	DADRAH0/DA13/ DACR0	DA12/ TEST	DA11/ PWME	DA10/—	DA9/ OEB	DA8/ OEA	DA7/OS	DA6/CKS	PWM0		8
H'FDB9	DADRAL0	DA5	DA4	DA3	DA2	DA1	DA0	CFS	—		
H'FDBA	DADRBH0/DA13/ DACNTH0	DA12/ —	DA11/ —	DA10/ —	DA9/ —	DA8/ —	DA7/ —	DA6/ —	—		
H'FDBB	DADRBL0/DA5/ DACNTL0	DA4/ —	DA3/ —	DA2/ —	DA1/ —	DA0/ —	CFS/ —	REGS	—		
H'FDBC	DADRAH1/DA13/ DACR1	DA12/ TEST	DA11/ PWME	DA10/—	DA9/OEB	DA8/OEA	DA7/OS	DA6/CKS	PWM1		8
H'FDBD	DADRAL1	DA5	DA4	DA3	DA2	DA1	DA0	CFS	—		
H'FDBE	DADRBH1/DA13/ DACNTH1	DA12/ —	DA11/ —	DA10/ —	DA9/ —	DA8/ —	DA7/ —	DA6/ —	—		
H'FDBF	DADRBL1/DA5/ DACNTL1	DA4/ —	DA3/ —	DA2/ —	DA1/ —	DA0/ —	CFS/ —	REGS	—		
H'FDC0	TCR2	CMIEB	CMIEA	OVIE	CCLR1	CCLR0	CKS2	CKS1	CKS0	TMR2,	16
H'FDC1	TCR3	CMIEB	CMIEA	OVIE	CCLR1	CCLR0	CKS2	CKS1	CKS0	TMR3	
H'FDC2	TCSR2	CMFB	CMFA	OVF	—	OS3	OS2	OS1	OS0		
H'FDC3	TCSR3	CMFB	CMFA	OVF	—	OS3	OS2	OS1	OS0		
H'FDC4	TCORA2										
H'FDC5	TCORA3										
H'FDC6	TCORB2										
H'FDC7	TCORB3										
H'FDC8	TCNT2										
H'FDC9	TCNT3										
H'FDD0	SMR3	C/Ā	CHR	PE	O/Ē	STOP	MP	CKS1	CKS0	SCI3,	8
	SMR3	GM	BLK	PE	O/Ē	BCP1	BCP0	CKS1	CKS0	Smart card interface	
H'FDD1	BRR3										
H'FDD2	SCR3	TIE	RIE	TE	RE	MPIE	TEIE	CKE1	CKE0		
H'FDD3	TDR3										

Register										Module Name	Data Bus Width (bits)	
Address	Name	Bit 7	Bit 6	Bit 5	Bit 4	Bit 3	Bit 2	Bit 1	Bit 0			
H'FDD4	SSR3	TDRE	RDRF	ORER	FER	PER	TEND	MPB	MPBT	SCI3, Smart card interface	8	
	SSR3	TDRE	RDRF	ORER	ERS	PER	TEND	MPB	MPBT			
H'FDD5	RDR3											
H'FDD6	SCMR3	—	—	—	—	SDIR	SINV	—	SMIF			
H'FDD8	SMR4	C/A	CHR	PE	O/E	STOP	MP	CKS1	CKS0	SCI4, Smart card interface	8	
	SMR4	GM	BLK	PE	O/E	BCP1	BCP0	CKS1	CKS0			
H'FDD9	BRR4											
H'FDDA	SCR4	TIE	RIE	TE	RE	MPIE	TEIE	CKE1	CKE0			
H'FDDB	TDR4											
H'FDDC	SSR4	TDRE	RDRF	ORER	FER	PER	TEND	MPB	MPBT			
	SSR4	TDRE	RDRF	ORER	ERS	PER	TEND	MPB	MPBT			
H'FDDD	RDR4											
H'FDD E	SCMR4	—	—	—	—	SDIR	SINV	—	SMIF			
H'FDE4	SBYCR	SSBY	STS2	SYS1	STS0	OPE	—	—	—	System	8	
H'FDE5	SYS CR	MACS	—	INTM1	INTM0	NMIEG	MRESE	—	RAME			
H'FDE6	SCKCR	PSTOP	—	—	—	STCS	SCK2	SCK1	SCK0			
H'FDE7	MDCR	—	—	—	—	—	MDS2	MDS1	MDS0			
H'FDE8	MSTPCRA	MSTPA7	MSTPA6	MSTPA5	MSTPA4	MSTPA3	MSTPA2	MSTPA1	MSTPA0			
H'FDE9	MSTPCRB	MSTPB7	MSTPB6	MSTPB5	MSTPB4	MSTPB3	MSTPB2	MSTPB1	MSTPB0			
H'FDEA	MSTPCRC	MSTPC7	MSTPC6	MSTPC5	MSTPC4	MSTPC3	MSTPC2	MSTPC1	MSTPC0			
H'FDEB	PF CR	CSS07	CSS36	BUZZE	LCASS	AE3	AE2	AE1	AE0			
H'FDEC	LPWRCR	DTON	LSON	NESEL	SUBSTP	RFCUT	—	STC1	STC0			
H'FE00	BARA	—	—	—	—	—	—	—	—	PBC	8	
H'FE01		BAA23	BAA22	BAA21	BAA20	BAA19	BAA18	BAA17	BAA16			
H'FE02		BAA15	BAA14	BAA13	BAA12	BAA11	BAA10	BAA9	BAA8			
H'FE03		BAA7	BAA6	BAA5	BAA4	BAA3	BAA2	BAA1	BAA0			
H'FE04	BARB	—	—	—	—	—	—	—	—			
H'FE05		BAA23	BAA22	BAA21	BAA20	BAA19	BAA18	BAA17	BAA16			
H'FE06		BAA15	BAA14	BAA13	BAA12	BAA11	BAA10	BAA9	BAA8			
H'FE07		BAA7	BAA6	BAA5	BAA4	BAA3	BAA2	BAA1	BAA0			
H'FE08	BCRA	CMFA	CDA	BAMRA2	BAMRA1	BAMRA0	CSELA1	CSELA0	BIEA			
H'FE09	BCRB	CMFB	CDB	BAMRB2	BAMRB1	BAMRB0	CSELB1	CSELB0	BIEB			
H'FE12	ISCRH	IRQ7SCB	IRQ7SCA	IRQ6SCB	IRQ6SCA	IRQ5SCB	IRQ5SCA	IRQ4SCB	IRQ4SCA	Interrupt controller	8	
H'FE13	ISCR L	IRQ3SCB	IRQ3SCA	IRQ2SCB	IRQ2SCA	IRQ1SCB	IRQ1SCA	IRQ0SCB	IRQ0SCA			
H'FE14	IER	IRQ7E	IRQ6E	IRQ5E	IRQ4E	IRQ3E	IRQ2E	IRQ1E	IRQ0E			
H'FE15	ISR	IRQ7F	IRQ6F	IRQ5F	IRQ4F	IRQ3F	IRQ2F	IRQ1F	IRQ0F			

Register										Module Name	Data Bus Width (bits)
Address	Name	Bit 7	Bit 6	Bit 5	Bit 4	Bit 3	Bit 2	Bit 1	Bit 0		
H'FE16	DTCEA	DTCEA7	DTCEA6	DTCEA5	DTCEA4	DTCEA3	DTCEA2	DTCEA1	DTCEA0	DTC	8
H'FE17	DTCEB	DTCEB7	DTCEB6	DTCEB5	DTCEB4	DTCEB3	DTCEB2	DTCEB1	DTCEB0		
H'FE18	DTCEC	DTCEC7	DTCEC6	DTCEC5	DTCEC4	DTCEC3	DTCEC2	DTCEC1	DTCEC0		
H'FE19	DTCED	DTCED7	DTCED6	DTCED5	DTCED4	DTCED3	DTCED2	DTCED1	DTCED0		
H'FE1A	DTCEE	DTCEE7	DTCEE6	DTCEE5	DTCEE4	DTCEE3	DTCEE2	DTCEE1	DTCEE0		
H'FE1B	DTCEF	DTCEF7	DTCEF6	DTCEF5	DTCEF4	DTCEF3	DTCEF2	DTCEF1	DTCEF0		
H'FE1E	DTCEI	DTCEI7	DTCEI6	DTCEI5	DTCEI4	DTCEI3	DTCEI2	DTCEI1	DTCEI0		
H'FE1F	DTVEC	DTVEC7	DTVEC6	DTVEC5	DTVEC4	DTVEC3	DTVEC2	DTVEC1	DTVEC0		
H'FE26	PCR	G3CMS1	G3CMS0	G2CMS1	G2CMS0	G1CMS1	G1CMS0	G0CMS1	G0CMS0	PPG	8
H'FE27	PMR	G3INV	G2INV	G1INV	G0INV	G3NOV	G2NOV	G1NOV	G0NOV		
H'FE28	NDERH	NDER15	NDER14	NDER13	NDER12	NDER11	NDER10	NDER9	NDER8		
H'FE29	NDERL	NDER7	NDER6	NDER5	NDER4	NDER3	NDER2	NDER1	NDER0		
H'FE2A	PODRH	POD15	POD14	POD13	POD12	POD11	POD10	POD9	POD8		
H'FE2B	PODRL	POD7	POD6	POD5	POD4	POD3	POD2	POD1	POD0		
H'FE2C	NDRH	NDR15	NDR14	NDR13	NDR12	NDR11	NDR10	NDR9	NDR8		
H'FE2D	NDRL	NDR7	NDR6	NDR5	NDR4	NDR3	NDR2	NDR1	NDR0		
H'FE2E	NDRH	—	—	—	—	NDR11	NDR10	NDR9	NDR8		
H'FE2F	NDRL	—	—	—	—	NDR3	NDR2	NDR1	NDR0		
H'FE30	P1DDR	P17DDR	P16DDR	P15DDR	P14DDR	P13DDR	P12DDR	P11DDR	P10DDR	Port	8
H'FE32	P3DDR	P37DDR	P36DDR	P35DDR	P34DDR	P33DDR	P32DDR	P31DDR	P30DDR		
H'FE36	P7DDR	P77DDR	P76DDR	P75DDR	P74DDR	P73DDR	P72DDR	P71DDR	P70DDR		
H'FE39	PADDR	—	—	—	—	PA3DDR	PA2DDR	PA1DDR	PA0DDR		
H'FE3A	PBDDR	PB7DDR	PB6DDR	PB5DDR	PB4DDR	PB3DDR	PB2DDR	PB1DDR	PB0DDR		
H'FE3B	PCDDR	PC7DDR	PC6DDR	PC5DDR	PC4DDR	PC3DDR	PC2DDR	PC1DDR	PC0DDR		
H'FE3C	PDDDR	PD7DDR	PD6DDR	PD5DDR	PD4DDR	PD3DDR	PD2DDR	PD1DDR	PD0DDR		
H'FE3D	PEDDR	PE7DDR	PE6DDR	PE5DDR	PE4DDR	PE3DDR	PE2DDR	PE1DDR	PE0DDR		
H'FE3E	PFDDR	PF7DDR	PF6DDR	PF5DDR	PF4DDR	PF3DDR	PF2DDR	PF1DDR	PF0DDR		
H'FE3F	PGDDR	—	—	—	PG4DDR	PG3DDR	PG2DDR	PG1DDR	PG0DDR		
H'FE40	PAPCR	—	—	—	—	PA3PCR	PA2PCR	PA1PCR	PA0PCR		
H'FE41	PBPCR	PB7PCR	PB6PCR	PB5PCR	PB4PCR	PB3PCR	PB2PCR	PB1PCR	PB0PCR		
H'FE42	PCPCR	PC7PCR	PC6PCR	PC5PCR	PC4PCR	PC3PCR	PC2PCR	PC1PCR	PC0PCR		
H'FE43	PDPCR	PD7PCR	PD6PCR	PD5PCR	PD4PCR	PD3PCR	PD2PCR	PD1PCR	PD0PCR		
H'FE44	PEPCR	PE7PCR	PE6PCR	PE5PCR	PE4PCR	PE3PCR	PE2PCR	PE1PCR	PE0PCR		
H'FE46	P3ODR	P37ODR	P36ODR	P35ODR	P34ODR	P33ODR	P32ODR	P31ODR	P30ODR		
H'FE47	PAODR	—	—	—	—	PA3ODR	PA2ODR	PA1ODR	PA0ODR		
H'FE48	PBODR	PB7ODR	PB6ODR	PB5ODR	PB4ODR	PB3ODR	PB2ODR	PB1ODR	PB0ODR		
H'FE49	PCODR	PC7ODR	PC6ODR	PC5ODR	PC4ODR	PC3ODR	PC2ODR	PC1ODR	PC0ODR		



Register										Module Name	Data Bus Width (bits)		
Address	Name	Bit 7	Bit 6	Bit 5	Bit 4	Bit 3	Bit 2	Bit 1	Bit 0				
H'FE80	TCR3	CCLR2	CCLR1	CCLR0	CKEG1	CKEG0	TPSC2	TPSC1	TPSC0	TPU3	16		
H'FE81	TMDR3	—	—	BFB	BFA	MD3	MD2	MD1	MD0				
H'FE82	TIOR3H	IOB3	IOB2	IOB1	IOB0	IOA3	IOA2	IOA1	IOA0				
H'FE83	TIOR3L	IOD3	IOD2	IOD1	IOD0	IOC3	IOC2	IOC1	IOC0				
H'FE84	TIER3	TTGE	—	—	TCIEV	TGIED	TGIEC	TGIEB	TGIEA				
H'FE85	TSR3	—	—	—	TCFV	TGFD	TGFC	TGFB	TGFA				
H'FE86	TCNT3												
H'FE87													
H'FE88	TGR3A												
H'FE89													
H'FE8A	TGR3B												
H'FE8B													
H'FE8C	TGR3C												
H'FE8D													
H'FE8E	TGR3D												
H'FE8F													
H'FE90	TCR4	—	CCLR1	CCLR0	CKEG1	CKEG0	TPSC2	TPSC1	TPSC0	TPU4	16		
H'FE91	TMDR4	—	—	—	—	MD3	MD2	MD1	MD0				
H'FE92	TIOR4	IOB3	IOB2	IOB1	IOB0	IOA3	IOA2	IOA1	IOA0				
H'FE94	TIER4	TTGE	—	TCIEU	TCIEV	—	—	TGIEB	TGIEA				
H'FE95	TSR4	TCFD	—	TCFU	TCFV	—	—	TGFB	TGFA				
H'FE96	TCNT4												
H'FE97													
H'FE98	TGR4A												
H'FE99													
H'FE9A	TGR4B												
H'FE9B													
H'FEA0	TCR5	—	CCLR1	CCLR0	CKEG1	CKEG0	TPSC2	TPSC1	TPSC0			TPU5	16
H'FEA1	TMDR5	—	—	—	—	MD3	MD2	MD1	MD0				
H'FEA2	TIOR5	IOB3	IOB2	IOB1	IOB0	IOA3	IOA2	IOA1	IOA0				
H'FEA4	TIER5	TTGE	—	TCIEU	TCIEV	—	—	TGIEB	TGIEA				
H'FEA5	TSR5	TCFD	—	TCFU	TCFV	—	—	TGFB	TGFA				
H'FEA6	TCNT5												
H'FEA7													
H'FEA8	TGR5A												
H'FEA9													
H'FEAA	TGR5B												
H'FEAB													

Register		Register								Module	Data Bus
Address	Name	Bit 7	Bit 6	Bit 5	Bit 4	Bit 3	Bit 2	Bit 1	Bit 0	Name	Width (bits)
H'FEB0	TSTR	—	—	CST5	CST4	CST3	CST2	CST1	CST0	TPU	16
H'FEB1	TSYR	—	—	SYNC5	SYNC4	SYNC3	SYNC2	SYNC1	SYNC0		
H'FEC0	IPRA	—	IPR6	IPR5	IPR4	—	IPR2	IPR1	IPR0	Interrupt controller	8
H'FEC1	IPRB	—	IPR6	IPR5	IPR4	—	IPR2	IPR1	IPR0		
H'FEC2	IPRC	—	IPR6	IPR5	IPR4	—	IPR2	IPR1	IPR0		
H'FEC3	IPRD	—	IPR6	IPR5	IPR4	—	IPR2	IPR1	IPR0		
H'FEC4	IPRE	—	IPR6	IPR5	IPR4	—	IPR2	IPR1	IPR0		
H'FEC5	IPRF	—	IPR6	IPR5	IPR4	—	IPR2	IPR1	IPR0		
H'FEC6	IPRG	—	IPR6	IPR5	IPR4	—	IPR2	IPR1	IPR0		
H'FEC7	IPRH	—	IPR6	IPR5	IPR4	—	IPR2	IPR1	IPR0		
H'FEC8	IPRI	—	IPR6	IPR5	IPR4	—	IPR2	IPR1	IPR0		
H'FEC9	IPRJ	—	IPR6	IPR5	IPR4	—	IPR2	IPR1	IPR0		
H'FECA	IPRK	—	IPR6	IPR5	IPR4	—	IPR2	IPR1	IPR0		
H'FECB	IPRL	—	IPR6	IPR5	IPR4	—	IPR2	IPR1	IPR0		
H'FECE	IPRO	—	IPR6	IPR5	IPR4	—	IPR2	IPR1	IPR0		
H'FED0	ABWCR	ABW7	ABW6	ABW5	ABW4	ABW3	ABW2	ABW1	ABW0	Bus controller	8
H'FED1	ASTCR	AST7	AST6	AST5	AST4	AST3	AST2	AST1	AST0		
H'FED2	WCRH	W71	W70	W61	W60	W51	W50	W41	W40		
H'FED3	WCRL	W31	W30	W21	W20	W11	W10	W01	W00		
H'FED4	BCRH	ICIS1	ICIS0	BRSTRM	BRSTS1	BRSTS0	RMTS2	RMTS1	RMST0		
H'FED5	BCRL	BRLE	BREQOE	—	OES	DDS	RCTS	WDBE	WAITE		
H'FED6	MCR	TPC	BE	RCDM	CW2	MXC1	MXC0	RLW1	RLW0		
H'FED7	DRAMCR	RFSHE	CBRM	RMODE	CMF	CMIE	CKS2	CKS1	CKS0		
H'FED8	RTCNT										
H'FED9	RTCOR										
H'FEDB	RAMER	—	—	—	—	RAMS	RAM2	RAM1	RAM0	FLASH	8
H'FEE0	MAR0AH	—	—	—	—	—	—	—	—	DMAC	16
H'FEE1											
H'FEE2	MAR0AL										
H'FEE3											
H'FEE4	IOAR0A										
H'FEE5											
H'FEE6	ETCR0A										
H'FEE7											
H'FEE8	MAR0BH	—	—	—	—	—	—	—	—		
H'FEE9											
H'FEEA	MAR0BL										
H'FEEB											

Register		Bit								Module	Data Bus
Address	Name	7	6	5	4	3	2	1	0	Name	Width (bits)
H'FEEC	IOAR0B									DMAC	16
H'FEED											
H'FEEE	ETCR0B										
H'FEF0	MAR1AH	—	—	—	—	—	—	—	—		
H'FEF1											
H'FEF2	MAR1AL										
H'FEF3											
H'FEF4	IOAR1A										
H'FEF5											
H'FEF6	ETCR1A										
H'FEF7											
H'FEF8	MAR1BH	—	—	—	—	—	—	—	—		
H'FEF9											
H'FEFA	MAR1BL										
H'FEFB											
H'FEFC	IOAR1B										
H'FEFD											
H'FEFE	ETCR1B										
H'FEFF											
H'FF00	P1DR	P17DR	P16DR	P15DR	P14DR	P13DR	P12DR	P11DR	P10DR	Port	8
H'FF01	—	—	—	—	—	—	—	—	—		
H'FF02	P3DR	P37DR	P36DR	P35DR	P34DR	P33DR	P32DR	P31DR	P30DR		
H'FF04	—	—	—	—	—	—	—	—	—		
H'FF05	—	—	—	—	—	—	—	—	—		
H'FF06	P7DR	P77DR	P76DR	P75DR	P74DR	P73DR	P72DR	P71DR	P70DR		
H'FF07	—	—	—	—	—	—	—	—	—		
H'FF09	PADR	—	—	—	—	PA3DR	PA2DR	PA1DR	PA0DR		
H'FF0A	PBDR	PB7DR	PB6DR	PB5DR	PB4DR	PB3DR	PB2DR	PB1DR	PB0DR		
H'FF0B	PCDR	PC7DR	PC6DR	PC5DR	PC4DR	PC3DR	PC2DR	PC1DR	PC0DR		
H'FF0C	PDDR	PD7DR	PD6DR	PD5DR	PD4DR	PD3DR	PD2DR	PD1DR	PD0DR		
H'FF0D	PEDR	PE7DR	PE6DR	PE5DR	PE4DR	PE3DR	PE2DR	PE1DR	PE0DR		
H'FF0E	PFDR	PF7DR	PF6DR	PF5DR	PF4DR	PF3DR	PF2DR	PF1DR	PF0DR		
H'FF0F	PGDR	—	—	—	PG4DR	PG3DR	PG2DR	PG1DR	PG0DR		
H'FF10	TCR0	CCLR2	CCLR1	CCLR0	CKEG1	CKEG0	TPSC2	TPSC1	TPSC0	TPU0	16
H'FF11	TMDR0	—	—	BFB	BFA	MD3	MD2	MD1	MD0		

Address	Register									Module Name	Data Bus Width (bits)				
	Name	Bit 7	Bit 6	Bit 5	Bit 4	Bit 3	Bit 2	Bit 1	Bit 0						
H'FF12	TIOR0H	IOB3	IOB2	IOB1	IOB0	IOA3	IOA2	IOA1	IOA0	TPU0	16				
H'FF13	TIOR0L	IOD3	IOD2	IOD1	IOD0	IOC3	IOC2	IOC1	IOC0						
H'FF14	TIER0	TTGE	—	—	TCIEV	TGIED	TGIEC	TGIEB	TGIEA						
H'FF15	TSR0	—	—	—	TCFV	TGFD	TGFC	TGFB	TGFA						
H'FF16	TCNT0														
H'FF17															
H'FF18	TGR0A														
H'FF19															
H'FF1A	TGR0B														
H'FF1B															
H'FF1C	TGR0C														
H'FF1D															
H'FF1E	TGR0D														
H'FF1F															
H'FF20	TCR1	—	CCLR1	CCLR0	CKEG1	CKEG0	TPSC2	TPSC1	TPSC0			TPU1	16		
H'FF21	TMDR1	—	—	—	—	MD3	MD2	MD1	MD0						
H'FF22	TIOR1	IOB3	IOB2	IOB1	IOB0	IOA3	IOA2	IOA1	IOA0						
H'FF24	TIER1	TTGE	—	TCIEU	TCIEV	—	—	TGIEB	TGIEA						
H'FF25	TSR1	TCFD	—	TCFU	TCFV	—	—	TGFB	TGFA						
H'FF26	TCNT1														
H'FF27															
H'FF28	TGR1A														
H'FF29															
H'FF2A	TGR1B														
H'FF2B															
H'FF30	TCR2	—	CCLR1	CCLR0	CKEG1	CKEG0	TPSC2	TPSC1	TPSC0	TPU2	16				
H'FF31	TMDR2	—	—	—	—	MD3	MD2	MD1	MD0						
H'FF32	TIOR2	IOB3	IOB2	IOB1	IOB0	IOA3	IOA2	IOA1	IOA0						
H'FF34	TIER2	TTGE	—	TCIEU	TCIEV	—	—	TGIEB	TGIEA						
H'FF35	TSR2	TCFD	—	TCFU	TCFV	—	—	TGFB	TGFA						
H'FF36	TCNT2														
H'FF37															
H'FF38	TGR2A														
H'FF39															

Register										Module	Data Bus	
Address	Name	Bit 7	Bit 6	Bit 5	Bit 4	Bit 3	Bit 2	Bit 1	Bit 0	Name	Width (bits)	
H'FF3A	TGR2B									TPU2	16	
H'FF3B												
H'FF60	DMAWER	—	—	—	—	WE1B	WE1A	WE0B	WE0A	DMAC	8	
H'FF61	DMATCR	—	—	TEE1	TEE0	—	—	—	—			
H'FF62	DMACR0A	DTSZ	DTID	RPE	DTDIR	DTF3	DTF2	DTF1	DTF0		16	
H'FF63	DMACR0B	DTSZ	DTID	RPE	DTDIR	DTF3	DTF2	DTF1	DTF0			
H'FF64	DMACR1A	DTSZ	DTID	RPE	DTDIR	DTF3	DTF2	DTF1	DTF0			
H'FF65	DMACR1B	DTSZ	DTID	RPE	DTDIR	DTF3	DTF2	DTF1	DTF0			
H'FF66	DMABCRH	FAE1	FAE0	SAE1	SAE0	DTA1B	DTA1A	DTA0B	DTA0A			
H'FF67	DMABCRH	DTE1B	DTE1A	DTE0B	DTE0A	DTIE1B	DTIE1A	DTIE0B	DTIE0A			
H'FF68	TCR0	CMIEB	CMIEA	OVIE	CCLR1	CCLR0	CKS2	CKS1	CKS0	TMR0,	16	
H'FF69	TCR1	CMIEB	CMIEA	OVIE	CCLR1	CCLR0	CKS2	CKS1	CKS0	TMR1		
H'FF6A	TCSR0	CMFB	CMFA	OVF	ADTE	OS3	OS2	OS1	OS0			
H'FF6B	TCSR1	CMFB	CMFA	OVF	—	OS3	OS2	OS1	OS0			
H'FF6C TCORA0												
H'FF6D TCORA1												
H'FF6E TCORB0												
H'FF6F TCORB1												
H'FF70 TCNT0												
H'FF71 TCNT1												
H'FF74	TCSR0/	OVF/	WT/IT/	TME/	—/	—/	CKS2/	CKS1/	CKS0/	WDT0	16	
	(write)	TCNT0										
H'FF75 TCNT0												
	(read)											
H'FF76	RSTCSR	WOVF	RSTE	RSTS	—	—	—	—	—			
	(write)											
H'FF77	RSTCSR	WOVF	RSTE	RSTS	—	—	—	—	—			
	(read)											
H'FF78	SMR0	C/A	CHR	PE	O/E	STOP	MP	CKS1	CKS0	SCI0, IIC0, 8		
	SMR0	GM	BLK	PE	O/E	BCP1	BCP0	CKS1	CKS0	Smart card		
	ICCR0	ICE	IEIC	MST	TRS	ACKE	BBSY	IRIC	SCP	interface		
H'FF79 BRR0												
	ICSR0	ESTP	STOP	IRTR	AASX	AL	AAS	ADZ	ACKB			
H'FF7A	SCR0	TIE	RIE	TE	RE	MPIE	TEIE	CKE1	CKE0			
H'FF7B TDR0												

Address	Register									Module Name	Data Bus Width (bits)
	Name	Bit 7	Bit 6	Bit 5	Bit 4	Bit 3	Bit 2	Bit 1	Bit 0		
H'FF7C	SSR0	TDRE	RDRF	ORER	FER	PER	TEND	MPB	MPBT	SCI0, IIC0, Smart card interface	8
	SSR0	TDRE	RDRF	ORER	ERS	PER	TEND	MPB	MPBT		
H'FF7D	RDR0										
H'FF7E	SCMR0	—	—	—	—	SDIR	SINV	—	SMIF		
	ICDR0/ SARX0	ICDR7/ SVAX6	ICDR6/ SVAX5	ICDR5/ SVAX4	ICDR4/ SVAX3	ICDR3/ SVAX2	ICDR2/ SVAX1	ICDR1/ SVAX0	ICDR0/ FSX		
H'FF7F	ICMR0/ SAR0	MLS/ SVA6	WAIT/ SVA5	CKS2/ SVA4	CKS1/ SVA3	CKS0/ SVA2	BC2/ SVA1	BC1/ SVA0	BC0/FS		
H'FF80	SMR1	C/ $\bar{A}$	CHR	PE	O/ $\bar{E}$	STOP	MP	CKS1	CKS0	SCI1, IIC1, Smart card interface	
	SMR1	GM	BLK	PE	O/ $\bar{E}$	BCP1	BCP0	CKS1	CKS0		
	ICCR1	ICE	IEIC	MST	TRS	ACKE	BBSY	IRIC	SCP		
H'FF81	BRR1										
	ICSR1	ESTP	STOP	IRTR	AASX	AL	AAS	ADZ	ACKB		
H'FF82	SCR1	TIE	RIE	TE	RE	MPIE	TEIE	CKE1	CKE0		
H'FF83	TDR1										
H'FF84	SSR1	TDRE	RDRF	ORER	FER	PER	TEND	MPB	MPBT		
	SSR1	TDRE	RDRF	ORER	ERS	PER	TEND	MPB	MPBT		
H'FF85	RDR1										
H'FF86	SCMR1	—	—	—	—	SDIR	SINV	—	SMIF		
	ICDR1/ SARX1	ICDR7/ SVARX6	ICDR6/ SVARX5	ICDR5/ SVARX4	ICDR4/ SVARX3	ICDR3/ SVARX2	ICDR2/ SVARX1	ICDR1/ SVARX0	ICDR0/ FSX		
H'FF87	ICMR1/ SAR1	MLS/ SVA6	WAIT/ SVA5	CKS2/ SVA4	CKS1/ SVA3	CKS0/ SVA2	BC2/ SVA1	BC1/ SVA0	BC0/FS	IIC1	8
H'FF88	SMR2	C/ $\bar{A}$	CHR	PE	O/ $\bar{E}$	STOP	MP	CKS1	CKS0	SCI2, Smart card interface	8
	SMR2	GM	BLK	PE	O/ $\bar{E}$	BCP1	BCP0	CKS1	CKS0		
H'FF89	BRR2										
H'FF8A	SCR2	TIE	RIE	TE	RE	MPIE	TEIE	CKE1	CKE0		
H'FF8B	TDR2										
H'FF8C	SSR2	TDRE	RDRF	ORER	FER	PER	TEND	MPB	MPBT		
	SSR2	TDRE	RDRF	ORER	FER	PER	TEND	MPB	MPBT		
H'FF8D	RDR2										
H'FF8E	SCMR2	—	—	—	—	SDIR	SINV	—	SMIF		
H'FF90	ADDRAH	AD9	AD8	AD7	AD6	AD5	AD4	AD3	AD2	A/D	8
H'FF91	ADDRAL	AD1	AD0	—	—	—	—	—	—		
H'FF92	ADDRBH	AD9	AD8	AD7	AD6	AD5	AD4	AD3	AD2		

Register		Register								Module	Data Bus
Address	Name	Bit 7	Bit 6	Bit 5	Bit 4	Bit 3	Bit 2	Bit 1	Bit 0	Name	Width (bits)
H'FF93	ADDRBL	AD1	AD0	—	—	—	—	—	—	A/D	8
H'FF94	ADDRCH	AD9	AD8	AD7	AD6	AD5	AD4	AD3	AD2		
H'FF95	ADDRCL	AD1	AD0	—	—	—	—	—	—		
H'FF96	ADDRDH	AD9	AD8	AD7	AD6	AD5	AD4	AD3	AD2		
H'FF97	ADDRDL	AD1	AD0	—	—	—	—	—	—		
H'FF98	ADCSR	ADF	ADIE	ADST	SCAN	CH3	CH2	CH1	CH0		
H'FF99	ADCR	TRGS1	TRGS0	—	—	CKS1	CKS0	—	—		
H'FFA2	TCSR1/ (write)	OVF/ TCNT1	WT/IT/	TME/	PSS/	RST/ NMI/	CKS2/	CKS1/	CKS0/	WDT1	16
H'FFA3	TCNT1 (read)										
H'FFA4	DADR0									D/A0,	8
H'FFA5	DADR1									D/A1	
H'FFA6	DACR01	DAOE1	DAOE0	DAE	—	—	—	—	—		
H'FFA8	FLMCR1	FWE	SWE1	ESU1	PSU1	EV1	PV1	E1	P1	FLASH	8
H'FFA9	FLMCR2	FLER	—	—	—	—	—	—	—		
H'FFAA	EBR1	EB7	EB6	EB5	EB4	EB3	EB2	EB1	EB0		
H'FFAB	EBR2	—	—	—	—	EB11	EB10	EB9	EB8		
H'FFAC	FLPWCR	PDWND	—	—	—	—	—	—	—		
H'FFB0	PORT1	P17	P16	P15	P14	P13	P12	P11	P10	Port	8
H'FFB2	PORT3	P37	P36	P35	P34	P33	P32	P31	P30		
H'FFB3	PORT4	P47	P46	P45	P44	P43	P42	P41	P40		
H'FFB6	PORT7	P77	P76	P75	P74	P73	P72	P71	P70		
H'FFB8	PORT9	P97	P96	P95	P94	P93	P92	P91	P90		
H'FFB9	PORTA	—	—	—	—	PA3	PA2	PA1	PA0		
H'FFBA	PORTB	PB7	PB6	PB5	PB4	PB3	PB2	PB1	PB0		
H'FFBB	PORTC	PC7	PC6	PC5	PC4	PC3	PC2	PC1	PC0		
H'FFBC	PORTD	PD7	PD6	PD5	PD4	PD3	PD2	PD1	PD0		
H'FFBD	PORTE	PE7	PE6	PE5	PE4	PE3	PE2	PE1	PE0		
H'FFBE	PORTF	PF7	PF6	PF5	PF4	PF3	PF2	PF1	PF0		
H'FFBF	PORTG	—	—	—	PG4	PG3	PG2	PG1	PG0		

Note: Undefined and reserved addresses are for use in future functional expansion or have test registers, etc., assigned to them. These registers must not be accessed, since operation in the event of such access, and subsequent operation, cannot be guaranteed .

## B.1B Addresses (H8S/2695)

Address	Register									Module Name	Data Bus Width (bits)
	Name	Bit 7	Bit 6	Bit 5	Bit 4	Bit 3	Bit 2	Bit 1	Bit 0		
H'FDD0	SMR3	C/ $\bar{A}$	CHR	PE	O/ $\bar{E}$	STOP	MP	CKS1	CKS0	SCI3, Smart card interface	8
	SMR3	GM	BLK	PE	O/ $\bar{E}$	BCP1	BCP0	CKS1	CKS0		
H'FDD1	BRR3										
H'FDD2	SCR3	TIE	RIE	TE	RE	MPIE	TEIE	CKE1	CKE0		
H'FDD3	TDR3										
H'FDD4	SSR3	TDRE	RDRF	ORER	FER	PER	TEND	MPB	MPBT		
	SSR3	TDRE	RDRF	ORER	ERS	PER	TEND	MPB	MPBT		
H'FDD5	RDR3										
H'FDD6	SCMR3	—	—	—	—	SDIR	SINV	—	SMIF		
H'FDD8	SMR4	C/ $\bar{A}$	CHR	PE	O/ $\bar{E}$	STOP	MP	CKS1	CKS0	SCI4, Smart card interface	8
	SMR4	GM	BLK	PE	O/ $\bar{E}$	BCP1	BCP0	CKS1	CKS0		
H'FDD9	BRR4										
H'FDDA	SCR4	TIE	RIE	TE	RE	MPIE	TEIE	CKE1	CKE0		
H'FDDB	TDR4										
H'FDDC	SSR4	TDRE	RDRF	ORER	FER	PER	TEND	MPB	MPBT		
	SSR4	TDRE	RDRF	ORER	ERS	PER	TEND	MPB	MPBT		
H'FDDD	RDR4										
H'FDEE	SCMR4	—	—	—	—	SDIR	SINV	—	SMIF		
H'FDE4	SBYCR	SSBY	STS2	SYS1	STS0	OPE	—	—	—	System	8
H'FDE5	SYSCR	MACS	—	INTM1	INTM0	NMIEG	MRESE	—	RAME		
H'FDE6	SCKCR	PSTOP	—	—	—	STCS	SCK2	SCK1	SCK0		
H'FDE7	MDCR	—	—	—	—	—	MDS2	MDS1	MDS0		
H'FDE8	MSTPCRA	MSTPA7	MSTPA6	MSTPA5	MSTPA4	MSTPA3	MSTPA2	MSTPA1	MSTPA0		
H'FDE9	MSTPCRB	MSTPB7	MSTPB6	MSTPB5	MSTPB4	MSTPB3	MSTPB2	MSTPB1	MSTPB0		
H'FDEA	MSTPCRC	MSTPC7	MSTPC6	MSTPC5	MSTPC4	MSTPC3	MSTPC2	MSTPC1	MSTPC0		
H'FDEB	PFCCR	CSS07	CSS36	BUZZE	LCASS	AE3	AE2	AE1	AE0		
H'FDEC	LPWRCCR	DTON	LSON	NESEL	SUBSTP	RFCUT	—	STC1	STC0		
H'FE12	ISCRH	IRQ7SCB	IRQ7SCA	IRQ6SCB	IRQ6SCA	IRQ5SCB	IRQ5SCA	IRQ4SCB	IRQ4SCA	Interrupt controller	8
H'FE13	ISCRH	IRQ3SCB	IRQ3SCA	IRQ2SCB	IRQ2SCA	IRQ1SCB	IRQ1SCA	IRQ0SCB	IRQ0SCA		
H'FE14	IER	IRQ7E	IRQ6E	IRQ5E	IRQ4E	IRQ3E	IRQ2E	IRQ1E	IRQ0E		
H'FE15	ISR	IRQ7F	IRQ6F	IRQ5F	IRQ4F	IRQ3F	IRQ2F	IRQ1F	IRQ0F		



Register										Module Name	Data Bus Width (bits)
Address	Name	Bit 7	Bit 6	Bit 5	Bit 4	Bit 3	Bit 2	Bit 1	Bit 0		
H'FE30	P1DDR	P17DDR	P16DDR	P15DDR	P14DDR	P13DDR	P12DDR	P11DDR	P10DDR	Port	8
H'FE32	P3DDR	P37DDR	P36DDR	P35DDR	P34DDR	P33DDR	P32DDR	P31DDR	P30DDR		
H'FE36	P7DDR	P77DDR	P76DDR	P75DDR	P74DDR	P73DDR	P72DDR	P71DDR	P70DDR		
H'FE39	PADDR	—	—	—	—	PA3DDR	PA2DDR	PA1DDR	PA0DDR		
H'FE3A	PBDDR	PB7DDR	PB6DDR	PB5DDR	PB4DDR	PB3DDR	PB2DDR	PB1DDR	PB0DDR		
H'FE3B	PCDDR	PC7DDR	PC6DDR	PC5DDR	PC4DDR	PC3DDR	PC2DDR	PC1DDR	PC0DDR		
H'FE3C	PDDDR	PD7DDR	PD6DDR	PD5DDR	PD4DDR	PD3DDR	PD2DDR	PD1DDR	PD0DDR		
H'FE3D	PEDDR	PE7DDR	PE6DDR	PE5DDR	PE4DDR	PE3DDR	PE2DDR	PE1DDR	PE0DDR		
H'FE3E	PFDDR	PF7DDR	PF6DDR	PF5DDR	PF4DDR	PF3DDR	PF2DDR	PF1DDR	PF0DDR		
H'FE3F	PGDDR	—	—	—	PG4DDR	PG3DDR	PG2DDR	PG1DDR	PG0DDR		
H'FE40	PAPCR	—	—	—	—	PA3PCR	PA2PCR	PA1PCR	PA0PCR		
H'FE41	PBPCR	PB7PCR	PB6PCR	PB5PCR	PB4PCR	PB3PCR	PB2PCR	PB1PCR	PB0PCR		
H'FE42	PCPCR	PC7PCR	PC6PCR	PC5PCR	PC4PCR	PC3PCR	PC2PCR	PC1PCR	PC0PCR		
H'FE43	PDPCR	PD7PCR	PD6PCR	PD5PCR	PD4PCR	PD3PCR	PD2PCR	PD1PCR	PD0PCR		
H'FE44	PEPCR	PE7PCR	PE6PCR	PE5PCR	PE4PCR	PE3PCR	PE2PCR	PE1PCR	PE0PCR		
H'FE46	P3ODR	P37ODR	P36ODR	P35ODR	P34ODR	P33ODR	P32ODR	P31ODR	P30ODR		
H'FE47	PAODR	—	—	—	—	PA3ODR	PA2ODR	PA1ODR	PA0ODR		
H'FE48	PBODR	PB7ODR	PB6ODR	PB5ODR	PB4ODR	PB3ODR	PB2ODR	PB1ODR	PB0ODR		
H'FE49	PCODR	PC7ODR	PC6ODR	PC5ODR	PC4ODR	PC3ODR	PC2ODR	PC1ODR	PC0ODR		
H'FE80	TCR3	CCLR2	CCLR1	CCLR0	CKEG1	CKEG0	TPSC2	TPSC1	TPSC0	TPU3	16
H'FE81	TMDR3	—	—	BFB	BFA	MD3	MD2	MD1	MD0		
H'FE82	TIOR3H	IOB3	IOB2	IOB1	IOB0	IOA3	IOA2	IOA1	IOA0		
H'FE83	TIOR3L	IOD3	IOD2	IOD1	IOD0	IOC3	IOC2	IOC1	IOC0		
H'FE84	TIER3	TTGE	—	—	TCIEV	TGIED	TGIEC	TGIEB	TGIEA		
H'FE85	TSR3	—	—	—	TCFV	TGFD	TGFC	TGFB	TGFA		
H'FE86	TCNT3										
H'FE87											
H'FE88	TGR3A										
H'FE89											
H'FE8A	TGR3B										
H'FE8B											
H'FE8C	TGR3C										
H'FE8D											
H'FE8E	TGR3D										
H'FE8F											

Register										Module	Data Bus	
Address	Name	Bit 7	Bit 6	Bit 5	Bit 4	Bit 3	Bit 2	Bit 1	Bit 0	Name	Width (bits)	
H'FE90	TCR4	—	CCLR1	CCLR0	CKEG1	CKEG0	TPSC2	TPSC1	TPSC0	TPU4	16	
H'FE91	TMDR4	—	—	—	—	MD3	MD2	MD1	MD0			
H'FE92	TIOR4	IOB3	IOB2	IOB1	IOB0	IOA3	IOA2	IOA1	IOA0			
H'FE94	TIER4	TTGE	—	TCIEU	TCIEV	—	—	TGIEB	TGIEA			
H'FE95	TSR4	TCFD	—	TCFU	TCFV	—	—	TGFB	TGFA			
H'FE96	TCNT4											
H'FE97												
H'FE98	TGR4A											
H'FE99												
H'FE9A	TGR4B											
H'FE9B												
H'FEA0	TCR5	—	CCLR1	CCLR0	CKEG1	CKEG0	TPSC2	TPSC1	TPSC0	TPU5	16	
H'FEA1	TMDR5	—	—	—	—	MD3	MD2	MD1	MD0			
H'FEA2	TIOR5	IOB3	IOB2	IOB1	IOB0	IOA3	IOA2	IOA1	IOA0			
H'FEA4	TIER5	TTGE	—	TCIEU	TCIEV	—	—	TGIEB	TGIEA			
H'FEA5	TSR5	TCFD	—	TCFU	TCFV	—	—	TGFB	TGFA			
H'FEA6	TCNT5											
H'FEA7												
H'FEA8	TGR5A											
H'FEA9												
H'FEAA	TGR5B											
H'FEAB												
H'FEB0	TSTR	—	—	CST5	CST4	CST3	CST2	CST1	CST0	TPU	16	
H'FEB1	TSYR	—	—	SYNC5	SYNC4	SYNC3	SYNC2	SYNC1	SYNC0			
H'FEC0	IPRA	—	IPR6	IPR5	IPR4	—	IPR2	IPR1	IPR0	Interrupt controller	8	
H'FEC1	IPRB	—	IPR6	IPR5	IPR4	—	IPR2	IPR1	IPR0			
H'FEC2	IPRC	—	IPR6	IPR5	IPR4	—	IPR2	IPR1	IPR0			
H'FEC3	IPRD	—	IPR6	IPR5	IPR4	—	IPR2	IPR1	IPR0			
H'FEC4	IPRE	—	IPR6	IPR5	IPR4	—	IPR2	IPR1	IPR0			
H'FEC5	IPRF	—	IPR6	IPR5	IPR4	—	IPR2	IPR1	IPR0			
H'FEC6	IPRG	—	IPR6	IPR5	IPR4	—	IPR2	IPR1	IPR0			
H'FEC7	IPRH	—	IPR6	IPR5	IPR4	—	IPR2	IPR1	IPR0			
H'FEC8	IPRI	—	IPR6	IPR5	IPR4	—	IPR2	IPR1	IPR0			
H'FEC9	IPRJ	—	IPR6	IPR5	IPR4	—	IPR2	IPR1	IPR0			
H'FECA	IPRK	—	IPR6	IPR5	IPR4	—	IPR2	IPR1	IPR0			
H'FECB	IPRL	—	IPR6	IPR5	IPR4	—	IPR2	IPR1	IPR0			
H'FECE	IPRO	—	IPR6	IPR5	IPR4	—	IPR2	IPR1	IPR0			

Register										Module Name	Data Bus Width (bits)		
Address	Name	Bit 7	Bit 6	Bit 5	Bit 4	Bit 3	Bit 2	Bit 1	Bit 0				
H'FED0	ABWCR	ABW7	ABW6	ABW5	ABW4	ABW3	ABW2	ABW1	ABW0	Bus controller	8		
H'FED1	ASTCR	AST7	AST6	AST5	AST4	AST3	AST2	AST1	AST0				
H'FED2	WCRH	W71	W70	W61	W60	W51	W50	W41	W40				
H'FED3	WCRL	W31	W30	W21	W20	W11	W10	W01	W00				
H'FED4	BCRH	ICIS1	ICIS0	BRSTRM	BRSTS1	BRSTS0	RMTS2	RMTS1	RMST0				
H'FED5	BCRL	BRLE	BREQOE	—	OES	DDS	RCTS	WDBE	WAITE				
H'FED6	MCR	TPC	BE	RCDM	CW2	MXC1	MXC0	RLW1	RLW0				
H'FED7	DRAMCR	RFSHE	CBRM	RMODE	CMF	CMIE	CKS2	CKS1	CKS0				
H'FED8	RTCNT												
H'FED9	RTCOR												
H'FEDB	RAMER	—	—	—	—	RAMS	RAM2	RAM1	RAM0	ROM	8		
H'FF00	P1DR	P17DR	P16DR	P15DR	P14DR	P13DR	P12DR	P11DR	P10DR	Port	8		
H'FF01	—	—	—	—	—	—	—	—	—				
H'FF02	P3DR	P37DR	P36DR	P35DR	P34DR	P33DR	P32DR	P31DR	P30DR				
H'FF04	—	—	—	—	—	—	—	—	—				
H'FF05	—	—	—	—	—	—	—	—	—				
H'FF06	P7DR	P77DR	P76DR	P75DR	P74DR	P73DR	P72DR	P71DR	P70DR				
H'FF07	—	—	—	—	—	—	—	—	—				
H'FF09	PADR	—	—	—	—	PA3DR	PA2DR	PA1DR	PA0DR				
H'FF0A	PBDR	PB7DR	PB6DR	PB5DR	PB4DR	PB3DR	PB2DR	PB1DR	PB0DR				
H'FF0B	PCDR	PC7DR	PC6DR	PC5DR	PC4DR	PC3DR	PC2DR	PC1DR	PC0DR				
H'FF0C	PDDR	PD7DR	PD6DR	PD5DR	PD4DR	PD3DR	PD2DR	PD1DR	PD0DR				
H'FF0D	PEDR	PE7DR	PE6DR	PE5DR	PE4DR	PE3DR	PE2DR	PE1DR	PE0DR				
H'FF0E	PFDR	PF7DR	PF6DR	PF5DR	PF4DR	PF3DR	PF2DR	PF1DR	PF0DR				
H'FF0F	PGDR	—	—	—	PG4DR	PG3DR	PG2DR	PG1DR	PG0DR				
H'FF10	TCR0	CCLR2	CCLR1	CCLR0	CKEG1	CKEG0	TPSC2	TPSC1	TPSC0			TPU0	16
H'FF11	TMDR0	—	—	BFB	BFA	MD3	MD2	MD1	MD0				
H'FF12	TIOR0H	IOB3	IOB2	IOB1	IOB0	IOA3	IOA2	IOA1	IOA0				
H'FF13	TIOR0L	IOD3	IOD2	IOD1	IOD0	IOC3	IOC2	IOC1	IOC0				
H'FF14	TIER0	TTGE	—	—	TCIEV	TGIED	TGIEC	TGIEB	TGIEA				
H'FF15	TSR0	—	—	—	TCFV	TGFD	TGFC	TGFB	TGFA				
H'FF16	TCNT0												
H'FF17													
H'FF18	TGR0A												
H'FF19													

Register										Module	Data Bus
Address	Name	Bit 7	Bit 6	Bit 5	Bit 4	Bit 3	Bit 2	Bit 1	Bit 0	Name	Width (bits)
H'FF1A	TGR0B									TPU0	16
H'FF1B											
H'FF1C	TGR0C										
H'FF1D											
H'FF1E	TGR0D										
H'FF1F											
H'FF20	TCR1	—	CCLR1	CCLR0	CKEG1	CKEG0	TPSC2	TPSC1	TPSC0	TPU1	16
H'FF21	TMDR1	—	—	—	—	MD3	MD2	MD1	MD0		
H'FF22	TIOR1	IOB3	IOB2	IOB1	IOB0	IOA3	IOA2	IOA1	IOA0		
H'FF24	TIER1	TTGE	—	TCIEU	TCIEV	—	—	TGIEB	TGIEA		
H'FF25	TSR1	TCFD	—	TCFU	TCFV	—	—	TGFB	TGFA		
H'FF26	TCNT1										
H'FF27											
H'FF28	TGR1A										
H'FF29											
H'FF2A	TGR1B										
H'FF2B											
H'FF30	TCR2	—	CCLR1	CCLR0	CKEG1	CKEG0	TPSC2	TPSC1	TPSC0	TPU2	16
H'FF31	TMDR2	—	—	—	—	MD3	MD2	MD1	MD0		
H'FF32	TIOR2	IOB3	IOB2	IOB1	IOB0	IOA3	IOA2	IOA1	IOA0		
H'FF34	TIER2	TTGE	—	TCIEU	TCIEV	—	—	TGIEB	TGIEA		
H'FF35	TSR2	TCFD	—	TCFU	TCFV	—	—	TGFB	TGFA		
H'FF36	TCNT2										
H'FF37											
H'FF38	TGR2A										
H'FF39											
H'FF3A	TGR2B										
H'FF3B											
H'FF74	TCSR0/ (write)	OVF/ TCNT0	WT/IT/	TME/	—/	—/	CKS2/	CKS1/	CKS0/	WDT0	16
H'FF75	TCNT0										
H'FF75	(read)										
H'FF76	RSTCSR	WOVF	RSTE	RSTS	—	—	—	—	—		
H'FF76	(write)										
H'FF77	RSTCSR	WOVF	RSTE	RSTS	—	—	—	—	—		
H'FF77	(read)										

Register										Module	Data Bus
Address	Name	Bit 7	Bit 6	Bit 5	Bit 4	Bit 3	Bit 2	Bit 1	Bit 0	Name	Width (bits)
H'FF78	SMR0	C/ $\bar{A}$	CHR	PE	O/ $\bar{E}$	STOP	MP	CKS1	CKS0	SCI0, Smart card interface	8
	SMR0	GM	BLK	PE	O/ $\bar{E}$	BCP1	BCP0	CKS1	CKS0		
	ICCR0	ICE	IEIC	MST	TRS	ACKE	BBSY	IRIC	SCP		
H'FF79	BRR0										
	ICSR0	ESTP	STOP	IRTR	AASX	AL	AAS	ADZ	ACKB		
H'FF7A	SCR0	TIE	RIE	TE	RE	MPIE	TEIE	CKE1	CKE0		
H'FF7B	TDR0										
H'FF7C	SSR0	TDRE	RDRF	ORER	FER	PER	TEND	MPB	MPBT		
	SSR0	TDRE	RDRF	ORER	ERS	PER	TEND	MPB	MPBT		
H'FF7D	RDR0										
H'FF7E	SCMR0	—	—	—	—	SDIR	SINV	—	SMIF		
	ICDR0/ SARX0	ICDR7/ SVAX6	ICDR6/ SVAX5	ICDR5/ SVAX4	ICDR4/ SVAX3	ICDR3/ SVAX2	ICDR2/ SVAX1	ICDR1/ SVAX0	ICDR0/ FSX		
H'FF7F	ICMR0/ SAR0	MLS/ SVA6	WAIT/ SVA5	CKS2/ SVA4	CKS1/ SVA3	CKS0/ SVA2	BC2/ SVA1	BC1/ SVA0	BC0/FS		
H'FF80	SMR1	C/ $\bar{A}$	CHR	PE	O/ $\bar{E}$	STOP	MP	CKS1	CKS0	SCI1, Smart card interface	8
	SMR1	GM	BLK	PE	O/ $\bar{E}$	BCP1	BCP0	CKS1	CKS0		
	ICCR1	ICE	IEIC	MST	TRS	ACKE	BBSY	IRIC	SCP		
H'FF81	BRR1										
	ICSR1	ESTP	STOP	IRTR	AASX	AL	AAS	ADZ	ACKB		
H'FF82	SCR1	TIE	RIE	TE	RE	MPIE	TEIE	CKE1	CKE0		
H'FF83	TDR1										
H'FF84	SSR1	TDRE	RDRF	ORER	FER	PER	TEND	MPB	MPBT		
	SSR1	TDRE	RDRF	ORER	ERS	PER	TEND	MPB	MPBT		
H'FF85	RDR1										
H'FF86	SCMR1	—	—	—	—	SDIR	SINV	—	SMIF		
	ICDR1/ SARX1	ICDR7/ SVARX6	ICDR6/ SVARX5	ICDR5/ SVARX4	ICDR4/ SVARX3	ICDR3/ SVARX2	ICDR2/ SVARX1	ICDR1/ SVARX0	ICDR0/ FSX		

Address	Register									Module Name	Data Bus Width (bits)
	Name	Bit 7	Bit 6	Bit 5	Bit 4	Bit 3	Bit 2	Bit 1	Bit 0		
H'FF88	SMR2	C/ $\bar{A}$	CHR	PE	O/ $\bar{E}$	STOP	MP	CKS1	CKS0	SCI2, Smart card interface	8
	SMR2	GM	BLK	PE	O/ $\bar{E}$	BCP1	BCP0	CKS1	CKS0		
H'FF89	BRR2										
H'FF8A	SCR2	TIE	RIE	TE	RE	MPIE	TEIE	CKE1	CKE0		
H'FF8B	TDR2										
H'FF8C	SSR2	TDRE	RDRF	ORER	FER	PER	TEND	MPB	MPBT		
	SSR2	TDRE	RDRF	ORER	FER	PER	TEND	MPB	MPBT		
H'FF8D	RDR2										
H'FF8E	SCMR2	—	—	—	—	SDIR	SINV	—	SMIF		
H'FF90	ADDRAH	AD9	AD8	AD7	AD6	AD5	AD4	AD3	AD2	A/D	8
H'FF91	ADDRAL	AD1	AD0	—	—	—	—	—	—		
H'FF92	ADDRBH	AD9	AD8	AD7	AD6	AD5	AD4	AD3	AD2		
H'FF93	ADDRBL	AD1	AD0	—	—	—	—	—	—		
H'FF94	ADDRCH	AD9	AD8	AD7	AD6	AD5	AD4	AD3	AD2		
H'FF95	ADDRCL	AD1	AD0	—	—	—	—	—	—		
H'FF96	ADDRDH	AD9	AD8	AD7	AD6	AD5	AD4	AD3	AD2		
H'FF97	ADDRDL	AD1	AD0	—	—	—	—	—	—		
H'FF98	ADCSR	ADF	ADIE	ADST	SCAN	CH3	CH2	CH1	CH0		
H'FF99	ADCR	TRGS1	TRGS0	—	—	CKS1	CKS0	—	—		
H'FFB0	PORT1	P17	P16	P15	P14	P13	P12	P11	P10	Port	8
H'FFB2	PORT3	P37	P36	P35	P34	P33	P32	P31	P30		
H'FFB3	PORT4	P47	P46	P45	P44	P43	P42	P41	P40		
H'FFB6	PORT7	P77	P76	P75	P74	P73	P72	P71	P70		
H'FFB8	PORT9	P97	P96	P95	P94	P93	P92	P91	P90		
H'FFB9	PORTA	—	—	—	—	PA3	PA2	PA1	PA0		
H'FFBA	PORTB	PB7	PB6	PB5	PB4	PB3	PB2	PB1	PB0		
H'FFBB	PORTC	PC7	PC6	PC5	PC4	PC3	PC2	PC1	PC0		
H'FFBC	PORTD	PD7	PD6	PD5	PD4	PD3	PD2	PD1	PD0		
H'FFBD	PORTE	PE7	PE6	PE5	PE4	PE3	PE2	PE1	PE0		
H'FFBE	PORTF	PF7	PF6	PF5	PF4	PF3	PF2	PF1	PF0		
H'FFBF	PORTG	—	—	—	PG4	PG3	PG2	PG1	PG0		

Note: Undefined and reserved addresses are for use in future functional expansion or have test registers, etc., assigned to them. These registers must not be accessed, since operation in the event of such access, and subsequent operation, cannot be guaranteed .

## B.2 Functions

<b>DADR0—D/A Data Register 0</b>	<b>H'FFA4</b>	<b>D/A0</b>
<b>DADR1—D/A Data Register 1</b>	<b>H'FFA5</b>	<b>D/A1</b>
<b>DADR2—D/A Data Register 2</b>	<b>H'FDAC</b>	<b>D/A2</b>
<b>DADR3—D/A Data Register 3</b>	<b>H'FDAD</b>	<b>D/A3</b>

Bit	:	7	6	5	4	3	2	1	0
Initial value	:	0	0	0	0	0	0	0	0
R/W	:	R/W	R/W	R/W	R/W	R/W	R/W	R/W	R/W

<b>DACR01—D/A Control Register 01</b>	<b>H'FFA6</b>	<b>D/A0, 1</b>
<b>DACR23—D/A Control Register 23</b>	<b>H'FDAE</b>	<b>D/A2, 3</b>

Bit	:	7	6	5	4	3	2	1	0
		DAOE1	DAOE0	DAE	—	—	—	—	—
Initial value	:	0	0	0	1	1	1	1	1
R/W	:	R/W	R/W	R/W	—	—	—	—	—

D/A enable

DAOE1	DAOE0	DAE	Description
0	0	*	Disables channel 0, 1 (channel 2, 3) D/A conversion.
		0	Enables channel 0 (channel 2) D/A conversion.
	1	0	Disables channel 1 (channel 3) D/A conversion.
1	0	1	Enables channel 0, 1 (channel 2, 3) D/A conversion.
		0	Disables channel 0 (channel 2) D/A conversion.
	1	1	Enables channel 1 (channel 3) D/A conversion.
1	1	*	Enables channel 0, 1 (channel 2, 3) D/A conversion.

\* : Don't care

D/A output enable 0

0	Disables analog output DA0 (DA2).
1	Enables channel 0 D/A conversion. Also enables analog output DA0 (DA2).

D/A output enable 1

0	Disables analog output DA1 (DA3).
1	Enables channel 1 D/A conversion. Also enables analog output DA1 (DA3).

**IrCR—IrDA Control Register**

**H'FDB0**

**SCI0, IrDA**

Bit	:	7	6	5	4	3	2	1	0
		IrE	IrCKS2	IrCKS1	IrCKS0	—	—	—	—
Initial value	:	0	0	0	0	0	0	0	0
R/W	:	R/W	R/W	R/W	R/W	—	—	—	—

IrDA clock select 2 to 0

Bit 6	Bit 5	Bit 4	Description
IrCKS2	IrCKS1	IrCKS0	
0	0	0	$B \times 3/16$ (3/16ths of bit rate)
		1	$\phi/2$
	1	0	$\phi/4$
		1	$\phi/8$
1	0	0	$\phi/16$
		1	$\phi/32$
	1	0	$\phi/64$
		1	$\phi/128$

IrDA enable

0	TxD0/IrTxD and RxD0/IrRxD pins function as TxD0 and RxD0.
1	TxD0/IrTxD and RxD0/IrRxD pins function as IrTx0 and IrRx0.

**SCRX—Serial Control Register X**

**H'FDB4**

**IIC**

Bit	:	7	6	5	4	3	2	1	0
		—	IICX1	IICX0	IICE	FLSHE	—	—	—
Initial value	:	0	0	0	0	0	0	0	0
R/W	:	R/W	R/W	R/W	R/W	R/W	R/W	R/W	R/W

Flash memory control register enable

I<sup>2</sup>C master enable

0	Disables CPU access of I <sup>2</sup> C bus interface data register and control register.
1	Enables CPU access of I <sup>2</sup> C bus interface data register and control register.

I<sup>2</sup>C transfer rate select 1, 0



**DDCSWR—DDC Switch Register**

**H'FDB5**

**IIC**

Bit	:	7	6	5	4	3	2	1	0
		—	—	—	—	CLR3	CLR2	CLR1	CLR0
Initial value	:	0	0	0	0	1	1	1	1
R/W	:	R/(W)*1	R/(W)*1	R/(W)*1	R/(W)*1	W*2	W*2	W*2	W*2

Reserved bit

IIC clear 3 to 0

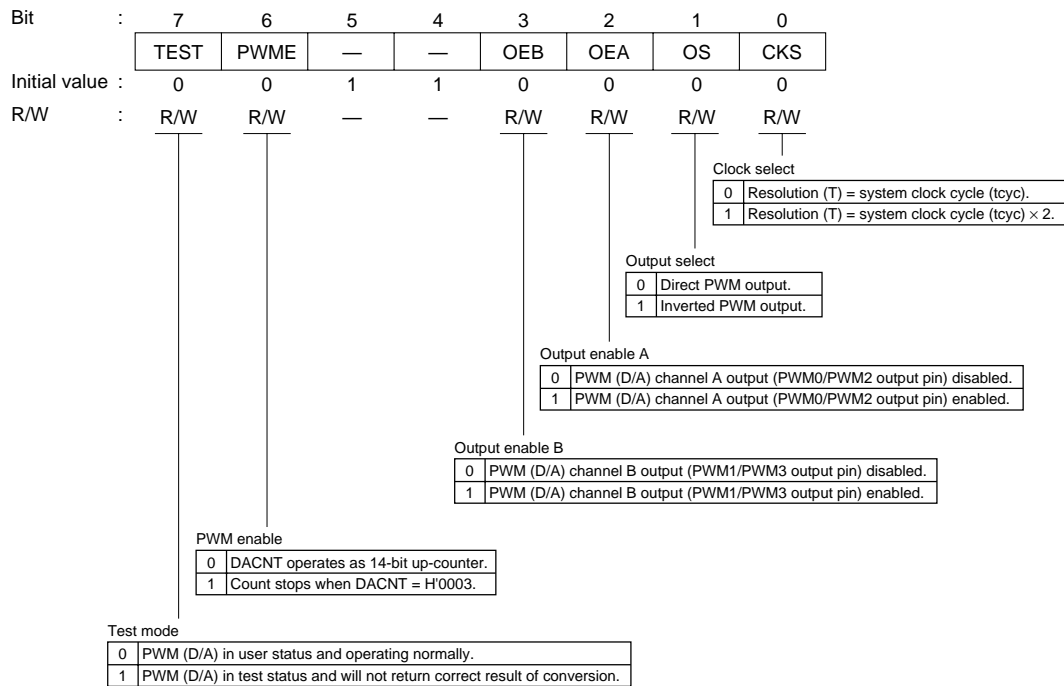
CLR3	CLR2	CLR1	CLR0	
0	0	—	—	Setting prohibited
				Setting prohibited
	1	0	0	IIC0 internal latch cleared
			1	IIC1 internal latch cleared
1	—	—	—	IIC0 and IIC1 internal latch cleared
			Invalid setting	

Notes: \*1 Should always be written with 0.  
 \*2 Always read as 1.

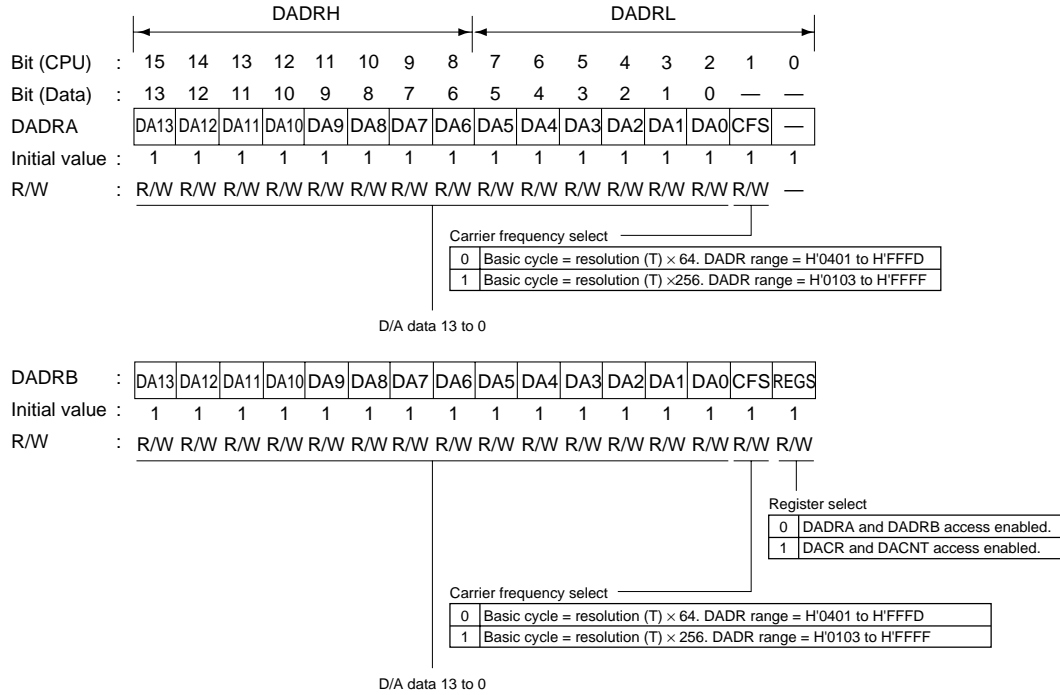
**DACR0—PWM (D/A) Control Register 0**  
**DACR1—PWM (D/A) Control Register 1**

**H'FDB8**  
**H'FDBC**

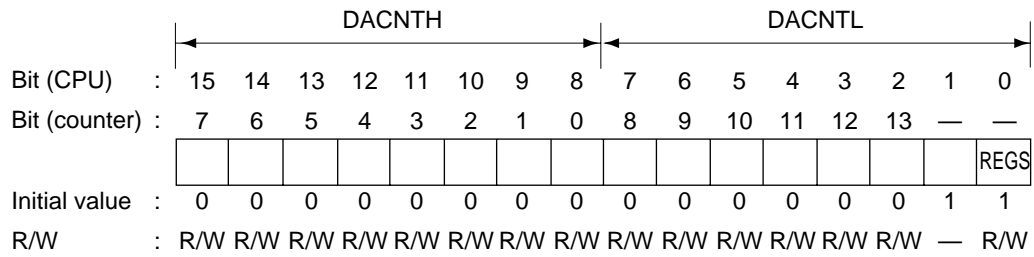
**PWM0**  
**PWM1**



<b>DADRAH0—PWM (D/A) Data Register AH0</b>	<b>H'FDB8</b>	<b>PWM0</b>
<b>DADRAL0—PWM (D/A) Data Register AL0</b>	<b>H'FDB9</b>	<b>PWM0</b>
<b>DADRBH0—PWM (D/A) Data Register BH0</b>	<b>H'FDBA</b>	<b>PWM0</b>
<b>DADRBL0—PWM (D/A) Data Register BL0</b>	<b>H'FDBB</b>	<b>PWM0</b>
<b>DADRAH1—PWM (D/A) Data Register AH1</b>	<b>H'FDBC</b>	<b>PWM1</b>
<b>DADRAL1—PWM (D/A) Data Register AL1</b>	<b>H'FDBD</b>	<b>PWM1</b>
<b>DADRBH1—PWM (D/A) Data Register BH1</b>	<b>H'FDBE</b>	<b>PWM1</b>
<b>DADRBL1—PWM (D/A) Data Register BL1</b>	<b>H'FDBF</b>	<b>PWM1</b>



<b>DACNTH0—PWM (D/A) Counter H0</b>	<b>H'FDBA</b>	<b>PWM0</b>
<b>DACNTL0—PWM (D/A) Counter L0</b>	<b>H'FDBB</b>	<b>PWM0</b>
<b>DACNTH1—PWM (D/A) Counter H1</b>	<b>H'FD BE</b>	<b>PWM1</b>
<b>DACNTL1—PWM (D/A) Counter L1</b>	<b>H'FDBF</b>	<b>PWM1</b>



Register select

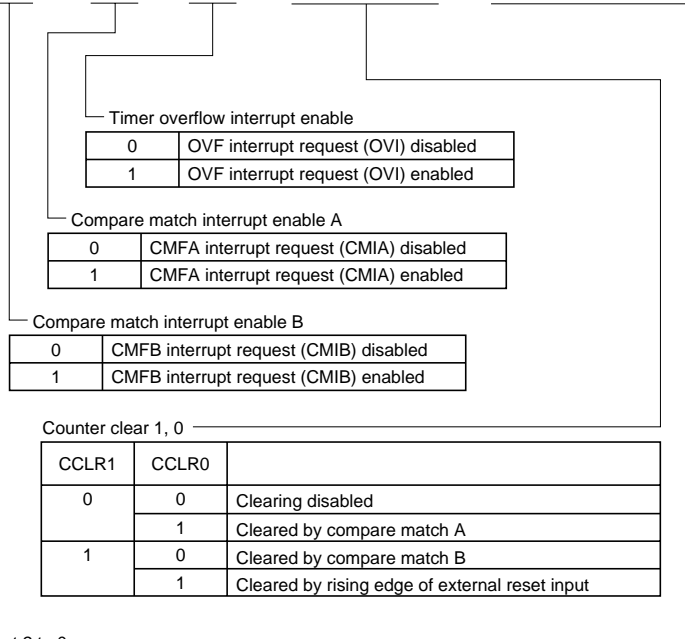
0	DADRA and DADRB access enabled
1	DACR and DACNT access enabled

TCR0—Timer Control Register 0  
 TCR1—Timer Control Register 1  
 TCR2—Timer Control Register 2  
 TCR3—Timer Control Register 3

H'FF68  
 H'FF69  
 H'FDC0  
 H'FDC1

TMR0  
 TMR1  
 TMR2  
 TMR3

Bit	:	7	6	5	4	3	2	1	0
		CMIEB	CMIEA	OVIE	CCLR1	CCLR0	CKS2	CKS1	CKS0
Initial value	:	0	0	0	0	0	0	0	0
R/W	:	R/W	R/W	R/W	R/W	R/W	R/W	R/W	R/W



0	OVF interrupt request (OVI) disabled
1	OVF interrupt request (OVI) enabled

0	CMFA interrupt request (CMIA) disabled
1	CMFA interrupt request (CMIA) enabled

0	CMFB interrupt request (CMIB) disabled
1	CMFB interrupt request (CMIB) enabled

Counter clear 1, 0		
CCLR1	CCLR0	
0	0	Clearing disabled
	1	Cleared by compare match A
1	0	Cleared by compare match B
	1	Cleared by rising edge of external reset input

Clock select 2 to 0			
CKS2	CKS1	CKS0	
0	0	0	Clock input disabled
		1	Internal clock: Counting on falling edge of $\phi/8$
	1	0	Internal clock: Counting on falling edge of $\phi/64$
		1	Internal clock: Counting on falling edge of $\phi/8192$
1	0	0	Channel 0: Counting on TCNT1 overflow signal * Channel 1: Counting on TCNT0 compare match A * Channel 2: Counting on TCNT3 overflow signal * Channel 3: Counting on TCNT2 compare match A *
		1	External clock: Counting on rising edge
	1	0	External clock: Counting on falling edge
		1	External clock: Counting on both rising and falling edges

Note: \* No countup clock is generated if the channel 0 (channel 2) clock input is the TCNT1 (TCNT3) overflow signal, and that the channel 1 (channel 3) clock input is the TCNT0 (TCNT2) compare match signal. Do not, therefore, attempt to make such a setting.

**TCSR0—Timer Control/Status Register 0**  
**TCSR1—Timer Control/Status Register 1**  
**TCSR2—Timer Control/Status Register 2**  
**TCSR3—Timer Control/Status Register 3**

**H'FF6A**  
**H'FF6B**  
**H'FDC2**  
**H'FDC3**

**TMR0**  
**TMR1**  
**TMR2**  
**TMR3**

**TCSR0**

Bit	7	6	5	4	3	2	1	0
	CMFB	CMFA	OVF	ADTE	OS3	OS2	OS1	OS0
Initial value :	0	0	0	0	0	0	0	0
R/W	R/(W)*	R/(W)*	R/(W)*	R/W	R/W	R/W	R/W	R/W

**TCSR1, TCSR3**

Bit	7	6	5	4	3	2	1	0
	CMFB	CMFA	OVF	—	OS3	OS2	OS1	OS0
Initial value :	0	0	0	1	0	0	0	0
R/W	R/(W)*	R/(W)*	R/(W)*	—	R/W	R/W	R/W	R/W

**TCSR2**

Bit	7	6	5	4	3	2	1	0
	CMFB	CMFA	OVF	—	OS3	OS2	OS1	OS0
Initial value :	0	0	0	0	0	0	0	0
R/W	R/(W)*	R/(W)*	R/(W)*	R/W	R/W	R/W	R/W	R/W

**Bit 7: Compare match flag B**

0	[Clearing] (1) Reading CMFB then writing 0 to CMFB when CMFB=1 (2) When DTC is started by CMIB interrupt and DTC MRB DISEL bit is 0
1	[Setting] When TCNT=TCORB

**Bit 6: Compare match flag A**

0	[Clearing] (1) Reading CMFA then writing 0 to CMFA when CMFA=1 (2) When DTC is started by CMIA interrupt and DTC MRB DISEL bit is 0
1	[Setting] When TCNT=TCORA

**Bit 5: Timer overflow flag**

0	[Clearing] Reading OVF then writing 0 to OVF when OVF=1
1	[Setting] When TCNT changes from H'FF to H'00

**Bit 4: A/D trigger enable**

0	A/D conversion start request by compare match A disabled
1	A/D conversion start request by compare match A enabled

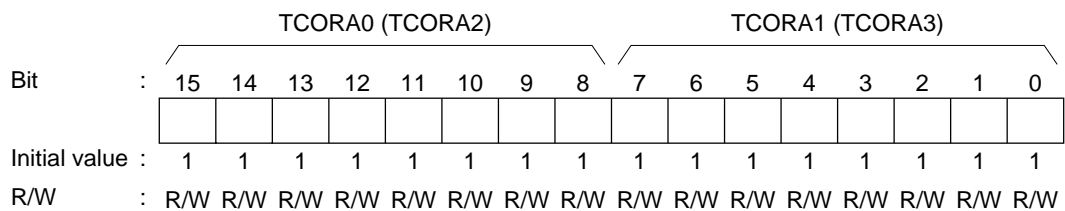
**Bits 3 to 0: Output select 3 to 0**

OS3	OS2	
0	0	No change at compare match B
	1	0 output at compare match B
1	0	1 output at compare match B
	1	Inverted output each compare match B (toggle output)

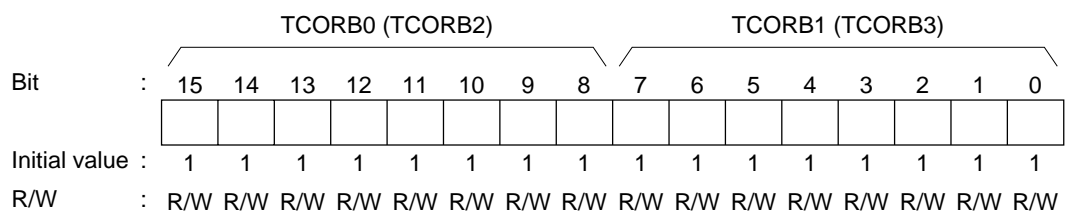
OS1	OS0	
0	0	No change at compare match A
	1	0 output at compare match A
1	0	1 output at compare match A
	1	Inverted output each compare match A (toggle output)

Note: \* Only 0 can be written to bits 7 to 5 (to clear these flags).

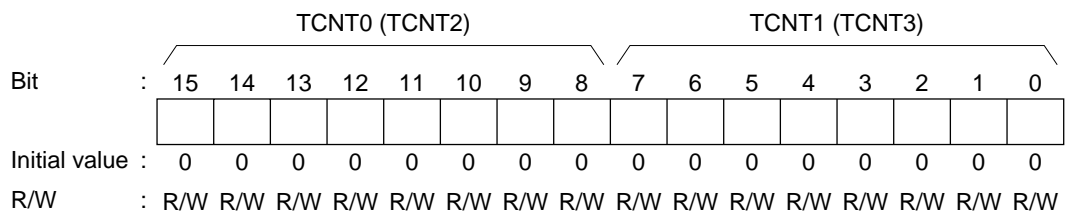
<b>TCORA0—Time Constant Register A0</b>	<b>H'FF6C</b>	<b>TMR0</b>
<b>TCORA1—Time Constant Register A1</b>	<b>H'FF6D</b>	<b>TMR1</b>
<b>TCORA2—Time Constant Register A2</b>	<b>H'FDC4</b>	<b>TMR2</b>
<b>TCORA3—Time Constant Register A3</b>	<b>H'FDC5</b>	<b>TMR3</b>



<b>TCORB0—Time Constant Register B0</b>	<b>H'FF6E</b>	<b>TMR0</b>
<b>TCORB1—Time Constant Register B1</b>	<b>H'FF6F</b>	<b>TMR1</b>
<b>TCORB2—Time Constant Register B2</b>	<b>H'FDC6</b>	<b>TMR2</b>
<b>TCORB3—Time Constant Register B3</b>	<b>H'FDC7</b>	<b>TMR3</b>



<b>TCNT0—Timer Counter 0</b>	<b>H'FF70</b>	<b>TMR0</b>
<b>TCNT1—Timer Counter 1</b>	<b>H'FF71</b>	<b>TMR1</b>
<b>TCNT2—Timer Counter 2</b>	<b>H'FDC8</b>	<b>TMR2</b>
<b>TCNT3—Timer Counter 3</b>	<b>H'FDC9</b>	<b>TMR3</b>

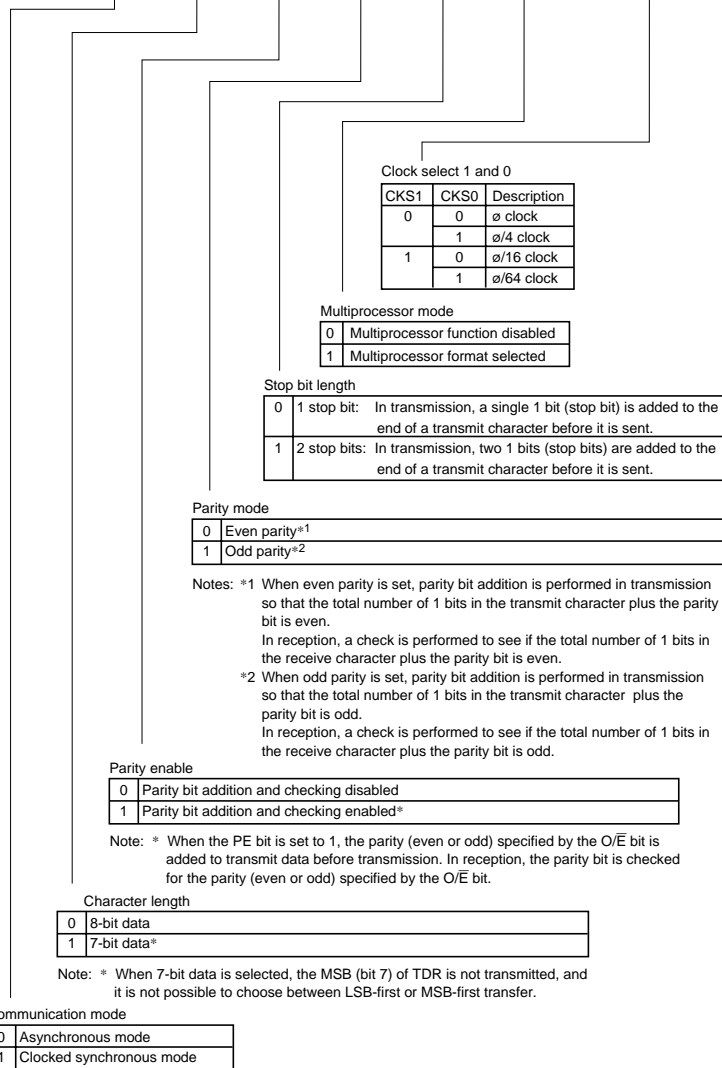


SMR0—Serial Mode Register 0  
 SMR1—Serial Mode Register 1  
 SMR2—Serial Mode Register 2  
 SMR3—Serial Mode Register 3  
 SMR4—Serial Mode Register 4

H'FF78  
 H'FF80  
 H'FF88  
 H'FDD0  
 H'FDD8

SCI0  
 SCI1  
 SCI2  
 SCI3  
 SCI4

Bit	:	7	6	5	4	3	2	1	0
		C/ $\bar{A}$	CHR	PE	O/ $\bar{E}$	STOP	MP	CKS1	CKS0
Initial value	:	0	0	0	0	0	0	0	0
R/W	:	R/W	R/W	R/W	R/W	R/W	R/W	R/W	R/W





**SMR0—Serial Mode Register 0**  
**SMR1—Serial Mode Register 1**  
**SMR2—Serial Mode Register 2**  
**SMR3—Serial Mode Register 3**  
**SMR4—Serial Mode Register 4**

**H'FF78**  
**H'FF80**  
**H'FF88**  
**H'FDD0**  
**H'FDD8**

**Smart Card**  
**Interface**

Bit	:	7	6	5	4	3	2	1	0
		GM	BLK	PE	O/E	BCP1	BCP0	CKS1	CKS0
Initial value	:	0	0	0	0	0	0	0	0
R/W	:	R/W	R/W	R/W	R/W	R/W	R/W	R/W	R/W

Basic clock pulse 1, 0

BCP1	BCP0	
0	0	32 clock
	1	64 clock
1	0	372 clock
	1	256 clock

Block transfer mode

0	Operation of normal smart card interface mode (1) Error signal output, detection, and automatic resending of data; (2) TXI interrupt generated by TEND flag; (3) TEND flag set 12.5etu after start of transmission (after 11.0etu in GSM mode).
1	Operation in block transfer mode (1) No error signal output, detection, or automatic resending of data; (2) TXI interrupt generated by TDRE flag; (3) TEND flag set 11.5etu after start of transmission (after 11.0etu in GSM mode).

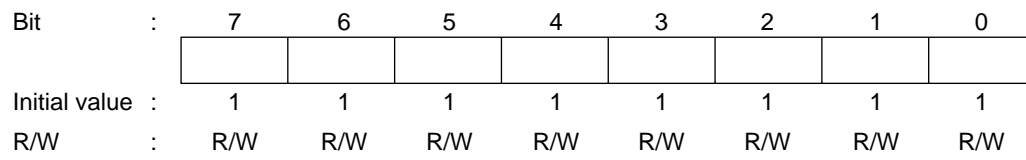
GSM Mode

0	Operation in normal smart card interface mode (1) TEND flag set 12.5etu (11.5etu in block transfer mode) after start of first bit; (2) ON/OFF control only of clock output.
1	Operation in GSM mode smart card interface mode (1) TEND flag set 11.0etu after start of first bit; (2) In addition to ON/OFF control of clock output, High/Low control also enabled (set by SCR).

Note: etu: Elementary Time Unit. The time to send 1 bit.

Note: Set bit 5 to 1 when using the smart card interface.

<b>BRR0—Bit Rate Register 0</b>	<b>H'FF79</b>	<b>SCI0</b>
<b>BRR1—Bit Rate Register 1</b>	<b>H'FF81</b>	<b>SCI1</b>
<b>BRR2—Bit Rate Register 2</b>	<b>H'FF89</b>	<b>SCI2</b>
<b>BRR3—Bit Rate Register 3</b>	<b>H'FDD1</b>	<b>SCI3</b>
<b>BRR4—Bit Rate Register 4</b>	<b>H'FDD9</b>	<b>SCI4</b>



<b>SCR0—Serial Control Register 0</b>	<b>H'FF7A</b>	<b>SCI0</b>
<b>SCR1—Serial Control Register 1</b>	<b>H'FF82</b>	<b>SCI1</b>
<b>SCR2—Serial Control Register 2</b>	<b>H'FF8A</b>	<b>SCI2</b>
<b>SCR3—Serial Control Register 3</b>	<b>H'FDD2</b>	<b>SCI3</b>
<b>SCR4—Serial Control Register 4</b>	<b>H'FDDA</b>	<b>SCI4</b>

Bit	7	6	5	4	3	2	1	0
	TIE	RIE	TE	RE	MPIE	TEIE	CKE1	CKE0
Initial value	0	0	0	0	0	0	0	0
R/W	R/W	R/W	R/W	R/W	R/W	R/W	R/W	R/W

Clock enable 1, 0		Description	
Bit 1	Bit 0		
CKE1	CKE0		
0	0	Async mode	Internal clock/SCK pin set as I/O port*1
	1	Clock sync mode	Internal clock/SCK pin set for sync clock output*1
1	0	Async mode	Internal clock/SCK pin set for clock output*2
		Clock sync mode	Internal clock/SCK pin set for sync clock output
	1	Async mode	External clock/SCK pin set for clock input*3
		Clock sync mode	External clock/SCK pin set for sync clock input

Notes: \*1 Initial value  
\*2 Clock output at same frequency as bit rate  
\*3 Clock input at 16 times frequency of bit rate

Transmit end interrupt enable	
0	Transmit end interrupt (TEI) requests disabled*
1	Transmit end interrupt (TEI) requests enabled*

Note: \* To cancel a TEI, clear SSR TDRE flag to 0 after reading TDRE=1, then either clear the TEND flag to 0 or clear the TEIE bit to 0.

Multiprocessor interrupt enable	
0	Multiprocessor interrupt disabled (normal receive operations) [Clearing] (1) Clear the MPIE bit to 0; (2) When data MPB=1 is received.
1	Multiprocessor interrupt enabled* Until data is received that the multiprocessor bit = 1, receive interrupt (RXI) requests, receive error interrupt (ERI) requests, and SSR RDRF, FER, and ORER flags cannot be set.

Note: \* On reception of receive data that includes MPB=0, the receive data is not sent from the RSR to the RDR, and, on detection of receive errors, the SSR RDRF, FER and ORER flags are not set. On reception of receive data that includes MPB=1, the SSR MPB bit is set to 1 and the MPIE bit is automatically cleared to 0. If an RXI or ERI interrupt request occurs (when the SCR TIE or RIE bit is set to 1), the FER and ORER flags can be set.

Receive enable	
0	Disable receive operation.*1
1	Enable receive operation.*2

Notes: \*1 Clearing the RE bit has no effect on the RDRF, FER, PER, or ORER flags.  
\*2 Serial receiving starts on detection of the start bit when in async mode, or on detection of sync clock input in clock sync mode.  
Before setting the RE bit to 1, be sure to set the SMR to decide the receive format.

Transmit enable	
0	Disable transmit operation.*1
1	Enable transmit operation.*2

Notes: \*1 The SSR TDRE flag is set to 1 (fixed).  
\*2 Transmission starts when, in this state, transmit data is written to TDR and the SSR TDRE flag is cleared to 0. Before setting the TE bit to 1, be sure to set the SMR to decide the transmit format.

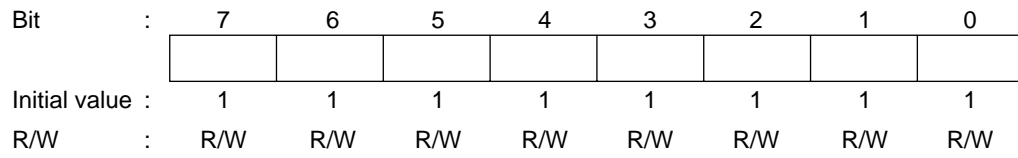
Receive interrupt enable	
0	Disable receive data full interrupt (RXI) requests and receive error interrupt (ERI) requests.*
1	Enable receive data full interrupt (RXI) requests and receive error interrupt (ERI) requests.

Note: \* To cancel RXI and ERI interrupt requests, either clear the RDRF or FER, PER, or ORER flags after reading "1", or clear the RIE bit to 0.

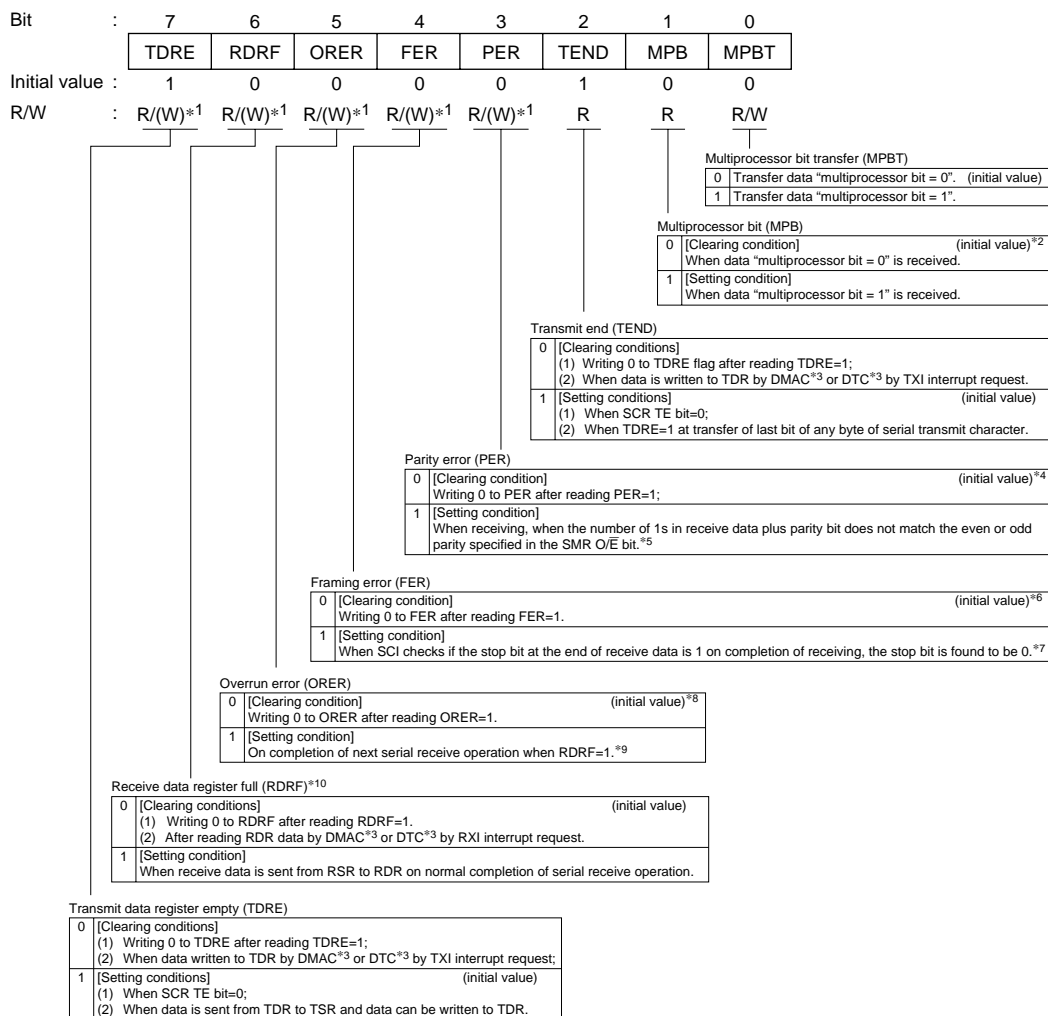
Transmit interrupt enable	
0	Disable transmit data empty interrupt (TXI) requests.
1	Enable transmit data empty interrupt (TXI) requests.

Note: To clear TXI interrupt requests, clear the TDRE flag to 0 after reading "1", or clear the TIE bit to 0.

<b>TDR0—Transmit Data Register 0</b>	<b>H'FF7B</b>	<b>SCI0</b>
<b>TDR1—Transmit Data Register 1</b>	<b>H'FF83</b>	<b>SCI1</b>
<b>TDR2—Transmit Data Register 2</b>	<b>H'FF8B</b>	<b>SCI2</b>
<b>TDR3—Transmit Data Register 3</b>	<b>H'FDD3</b>	<b>SCI3</b>
<b>TDR4—Transmit Data Register 4</b>	<b>H'FDDB</b>	<b>SCI4</b>



SSR0—Serial Status Register 0	H'FF7C	SCI0
SSR1—Serial Status Register 1	H'FF84	SCI1
SSR2—Serial Status Register 2	H'FF8C	SCI2
SSR3—Serial Status Register 3	H'FDD4	SCI3
SSR4—Serial Status Register 4	H'FDDC	SCI4



- Notes: \*1 Only 0 can be written to these bits (to clear these flags).  
\*2 The existing status is continued when, in multi-processor format, the SCR RE bit is cleared to 0.  
\*3 This function is not available in the H8S/2695.  
\*4 The PER flag is not affected and retains its previous state when the RE bit in SCR is cleared to 0.  
\*5 If a parity error occurs, the receive data is transferred to RDR but the RDRF flag is not set. Also, subsequent serial reception cannot be continued while the PER flag is set to 1. In clocked synchronous mode, serial transmission cannot be continued, either.  
\*6 The FER flag is not affected and retains its previous state when the RE bit in SCR is cleared to 0.  
\*7 In 2-stop-bit mode, only the first stop bit is checked for a value of 0; the second stop bit is not checked. If a framing error occurs, the receive data is transferred to RDR but the RDRF flag is not set. Also, subsequent serial reception cannot be continued while the FER flag is set to 1. In clocked synchronous mode, serial transmission cannot be continued, either.  
\*8 The ORER flag is not affected and retains its previous state when the RE bit in SCR is cleared to 0.  
\*9 The receive data prior to the overrun error is retained in RDR, and the data received subsequently is lost. Also, subsequent serial reception cannot be continued while the ORER flag is set to 1. In clocked synchronous mode, serial transmission cannot be continued, either.  
\*10 RDR and the RDRF flag are not affected and retain their previous values when an error is detected during reception or when the RE bit in SCR is cleared to 0. If reception of the next data is completed while the RDRF flag is still set to 1, an overrun error will occur and the receive data will be lost.

<b>RDR0—Receive Data Register 0</b>	<b>H'FF7D</b>	<b>SCI0</b>
<b>RDR1—Receive Data Register 1</b>	<b>H'FF85</b>	<b>SCI1</b>
<b>RDR2—Receive Data Register 2</b>	<b>H'FF8D</b>	<b>SCI2</b>
<b>RDR3—Receive Data Register 3</b>	<b>H'FDD5</b>	<b>SCI3</b>
<b>RDR4—Receive Data Register 4</b>	<b>H'FDDD</b>	<b>SCI4</b>

Bit	:	7	6	5	4	3	2	1	0										
		<table border="1" style="width: 100%; height: 20px;"> <tr> <td style="width: 12.5%;"></td> <td style="width: 12.5%;"></td> <td style="width: 12.5%;"></td> <td style="width: 12.5%;"></td> <td style="width: 12.5%;"></td> <td style="width: 12.5%;"></td> <td style="width: 12.5%;"></td> <td style="width: 12.5%;"></td> <td style="width: 12.5%;"></td> <td style="width: 12.5%;"></td> </tr> </table>																	
Initial value	:	0	0	0	0	0	0	0	0										
R/W	:	R	R	R	R	R	R	R	R										

<b>SCMR0—Smart Card Mode Register 0</b>	<b>H'FF7E</b>	<b>SCI0</b>
<b>SCMR1—Smart Card Mode Register 1</b>	<b>H'FF86</b>	<b>SCI1</b>
<b>SCMR2—Smart Card Mode Register 2</b>	<b>H'FF8E</b>	<b>SCI2</b>
<b>SCMR3—Smart Card Mode Register 3</b>	<b>H'FDD6</b>	<b>SCI3</b>
<b>SCMR4—Smart Card Mode Register 4</b>	<b>H'FDDE</b>	<b>SCI4</b>

Bit	:	7	6	5	4	3	2	1	0								
		<table border="1" style="width: 100%; height: 20px;"> <tr> <td style="width: 12.5%; text-align: center;">—</td> <td style="width: 12.5%; text-align: center;">—</td> <td style="width: 12.5%; text-align: center;">—</td> <td style="width: 12.5%; text-align: center;">—</td> <td style="width: 12.5%; text-align: center;">SDIR</td> <td style="width: 12.5%; text-align: center;">SINV</td> <td style="width: 12.5%; text-align: center;">—</td> <td style="width: 12.5%; text-align: center;">SMIF</td> </tr> </table>								—	—	—	—	SDIR	SINV	—	SMIF
—	—	—	—	SDIR	SINV	—	SMIF										
Initial value	:	1	1	1	1	0	0	1	0								
R/W	:	—	—	—	—	R/W	R/W	—	R/W								

Smart card interface mode select

0	Operates as normal SCI (smart card interface function disabled)
1	Enables smart card interface function.

Smart card data invert

0	TDR contents are transmitted without modification Receive data is stored in RDR without modification
1	TDR contents are inverted before being transmitted Receive data is stored in RDR in inverted form

Smart card data transfer direction

0	Sends TDR contents LSB first; Receive data stored in RDR as LSB first.
1	Sends TDR contents MSB first; Receive data stored in RDR as MSB first.

**SBYCR—Standby Control Register**

**H'FDE4**

**System**

Bit	:	7	6	5	4	3	2	1	0
		SSBY	STS2	STS1	STS0	OPE	—	—	—
Initial value	:	0	0	0	0	1	0	0	0
R/W	:	R/W	R/W	R/W	R/W	R/W	—	—	—

Output port enable

0	In software standby mode, watch mode, and during direct transfer, the address bus and bus control signal are in the high-impedance state.
1	In software standby mode, watch mode, and during direct transfer, the address bus and bus control signal remain in the output state.

Standby timer select 2 to 0

STS2	STS1	STS0	
0	0	0	Hold time: 8192 states
		1	Hold time: 16384 states
	1	0	Hold time: 32768 states
		1	Hold time: 65536 states
1	0	0	Hold time: 131072 states
		1	Hold time: 262144 states
	1	0	Reserved
		1	Hold time: 16 states*

Note: \* This setting should not be selected with this product.

Software standby

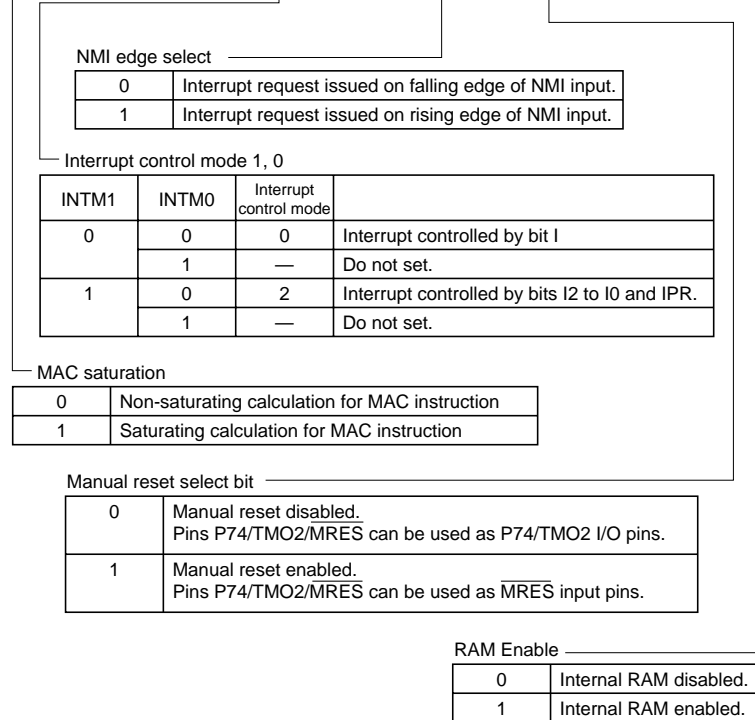
0	When the SLEEP command is executed in high-speed or medium-speed modes, the operation enters sleep mode. When the SLEEP command is executed in sub-active mode, the operation enters sub-sleep mode.
1	When the SLEEP command is executed in high-speed and medium-speed modes, operation enters software standby mode, sub-active mode, and watch mode. When the SLEEP command is executed in sub-active mode, operation enters watch mode and high-speed mode.

**SYSCR—System Control Register**

**H'FDE5**

**System**

Bit	:	7	6	5	4	3	2	1	0
		MACS	—	INTM1	INTM0	NMIEG	MRESE	—	RAME
Initial value	:	0	0	0	0	0	0	0	1
R/W	:	R/W	—	R/W	R/W	R/W	R/W	—	R/W





**SCKCR—System Clock Control Register**

**H'FDE6**

**System**

Bit	:	7	6	5	4	3	2	1	0
		PSTOP	—	—	—	STCS	SCK2	SCK1	SCK0
Initial value	:	0	0	0	0	0	0	0	0
R/W	:	R/W	—	—	—	R/W	R/W	R/W	R/W

System clock select 2 to 0

SCK2	SCK1	SCK0	
0	0	0	Bus master set to high-speed mode.
		1	Medium-speed clock: $\phi/2$
	1	0	Medium-speed clock: $\phi/4$
		1	Medium-speed clock: $\phi/8$
1	0	0	Medium-speed clock: $\phi/16$
		1	Medium-speed clock: $\phi/32$
	1	—	—

Frequency multiplier switching mode select

0	Specified multiplier valid after transferring to software standby mode, watch mode, and sub-active mode.
1	Specified multiplier valid immediately after setting value in STC bit.

$\phi$  clock output disable

PSTOP	High-speed mode, medium-speed mode, sub-active mode	Sleep mode, sub-sleep mode	Software standby mode, watch mode, direct transition	Hardware standby mode
0	$\phi$ output (initial value)	$\phi$ output	High level (fixed)	High impedance
1	High level (fixed)	High level (fixed)	High level (fixed)	High impedance

**MDCR—Mode Control Register****H'FDE7****System**

Bit	:	7	6	5	4	3	2	1	0
		—	—	—	—	—	MDS2	MDS1	MDS0
Initial value	:	1	0	0	0	0	—*	—*	—*
R/W	:	R/W	—	—	—	—	R	R	R

Mode select 2 to 0

Note: \* Determined by pins MD2 to MD0.

**MSTPCRA—Module Stop Control Register A****H'FDE8****System**

Bit	:	7	6	5	4	3	2	1	0
		MSTPA7	MSTPA6	MSTPA5	MSTPA4	MSTPA3	MSTPA2	MSTPA1	MSTPA0
Initial value	:	0	0	1	1	1	1	1	1
R/W	:	R/W	R/W	R/W	R/W	R/W	R/W	R/W	R/W

Module stop

0	DMAC module stop mode is cleared.
1	DMAC module stop mode is set.

**MSTPCRB—Module Stop Control Register B****H'FDE9****System**

Bit	:	7	6	5	4	3	2	1	0
		MSTPB7	MSTPB6	MSTPB5	MSTPB4	MSTPB3	MSTPB2	MSTPB1	MSTPB0
Initial value	:	1	1	1	1	1	1	1	1
R/W	:	R/W	R/W	R/W	R/W	R/W	R/W	R/W	R/W

Module stop

0	IIC channel 1 module stop mode canceled.
1	IIC channel 1 module stop mode enabled.

Module stop

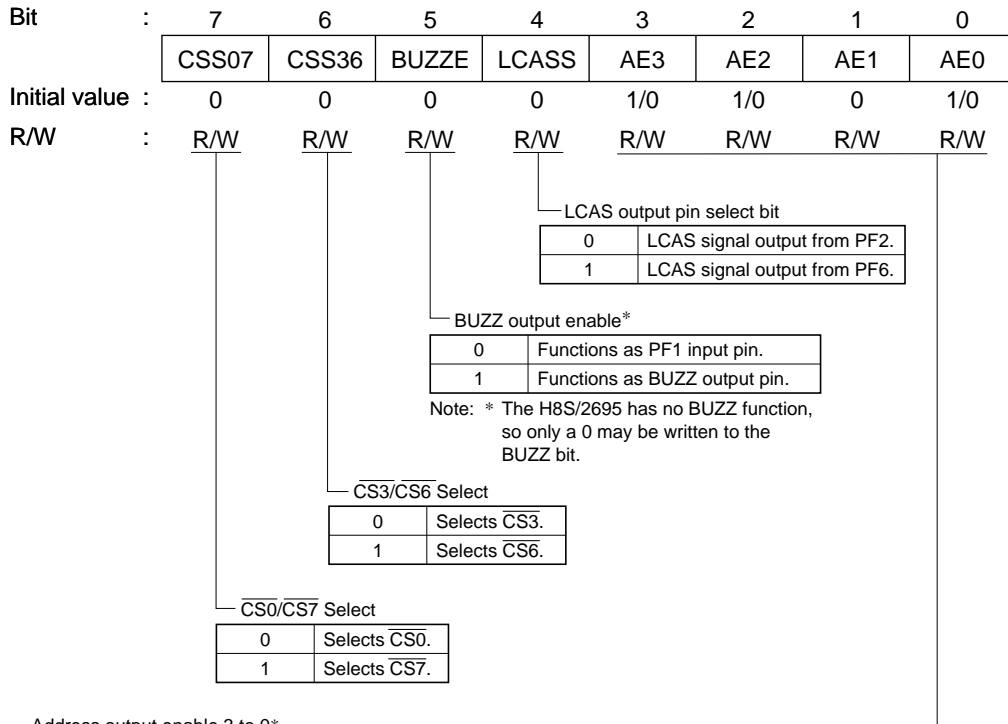
0	IIC channel 0 module stop mode canceled.
1	Channel 0 module stop mode enabled.

**MSTPCRC—Module Stop Control Register C****H'FDEA****System**

Bit	:	7	6	5	4	3	2	1	0
		MSTPC7	MSTPC6	MSTPC5	MSTPC4	MSTPC3	MSTPC2	MSTPC1	MSTPC0
Initial value	:	1	1	1	1	1	1	1	1
R/W	:	R/W	R/W	R/W	R/W	R/W	R/W	R/W	R/W

Module stop

0	PC brake controller module stop mode canceled.
1	PC brake controller module stop mode enabled.

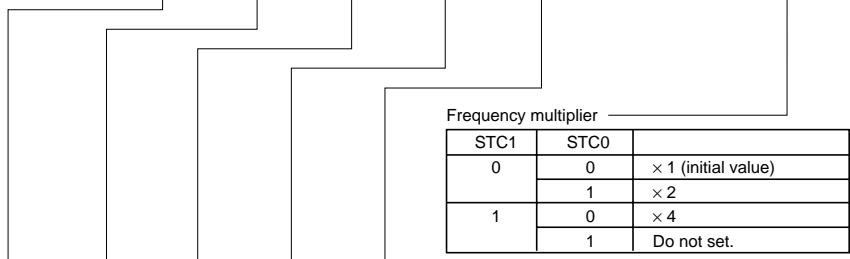


Address output enable 3 to 0\*

AE3	AE2	AE1	AE0	
0	0	0	0	A8 to A23 address output disabled.
0	0	0	1	A8 address output enabled. A9 to A23 address output disabled.
0	0	1	0	A8 and A9 address output enabled. A10 to A23 address output disabled.
0	0	1	1	A8 to A10 address output enabled. A11 to A23 address output disabled.
0	1	0	0	A8 to A11 address output enabled. A12 to A23 address output disabled.
0	1	0	1	A8 to A12 address output enabled. A13 to A23 address output disabled.
0	1	1	0	A8 to A13 address output enabled. A14 to A23 address output disabled.
0	1	1	1	A8 to A14 address output enabled. A15 to A23 address output disabled.
1	0	0	0	A8 to A15 address output enabled. A16 to A23 address output disabled.
1	0	0	1	A8 to A16 address output enabled. A17 to A23 address output disabled.
1	0	1	0	A8 to A17 address output enabled. A18 to A23 address output disabled.
1	0	1	1	A8 to A18 address output enabled. A19 to A23 address output disabled.
1	1	0	0	A8 to A19 address output enabled. A20 to A23 address output disabled.
1	1	0	1	A8 to A20 address output enabled. A21 to A23 address output disabled.
1	1	1	0	A8 to A21 address output enabled. A22 and A23 address output disabled.
1	1	1	1	A8 to A23 address output enabled.

Note: \* In expanded mode with ROM, bits AE3 to AE0 are initialized to B'0000.  
 In ROMless expanded mode, bits AE3 to AE0 are initialized to B'1101.  
 Address pins A0 to A7 are made address outputs by setting the corresponding DDR bits to 1.

Bit	:	7	6	5	4	3	2	1	0
		DTON*1	LSON*1	NESEL*1	SUBSTP*1	RFCUT*1	—	STC1	STC0
Initial value	:	0	0	0	0	0	0	0	0
R/W	:	R/W	R/W	R/W	R/W	R/W	R/W	R/W	R/W



Frequency multiplier

STC1	STC0	
0	0	× 1 (initial value)
	1	× 2
1	0	× 4
	1	Do not set.

Note: A system clock frequency multiplied by the multiplication factor (STC1 and STC0) should not exceed the maximum operating frequency defined in section 25, 26, and 27, Electrical Characteristics.

Oscillator circuit feedback resistor control bit

0	Feedback resistor ON when main clock operating; OFF when not operation.
1	Feedback resistor OFF.

Subclock enable

0	Subclock generation enabled.
1	Subclock generation disabled.

Noise elimination sampling frequency select

0	Sampling uses $\phi/32$ clock.
1	Sampling uses $\phi/4$ clock.

Low-speed ON flag

0	<ul style="list-style-type: none"> <li>When the SLEEP command is executed in high-speed mode or medium-speed mode, operation transfers to sleep mode, software standby mode, or watch mode*.</li> <li>When the SLEEP command is executed in sub-active mode*, operation transfers to watch mode*, or directly to high-speed mode.</li> <li>Operation transfers to high-speed mode after watch mode* is canceled.</li> </ul>
1	<ul style="list-style-type: none"> <li>When the SLEEP command is executed in high-speed mode, operation transfers to watch mode* or sub-active mode.</li> <li>When the SLEEP command is executed in sub-active mode*, operation transfers to sub-sleep mode or watch mode*.</li> <li>Operation transfers to sub-active mode immediately watch mode* is canceled.</li> </ul>

Note: \* Always select high-speed mode when transferring to watch mode or sub-active mode.

Direct transfer ON flag

0	<ul style="list-style-type: none"> <li>When the SLEEP command is executed in high-speed mode or medium-speed mode, operation transfers to sleep mode, software standby mode, or watch mode*.</li> <li>When the SLEEP command is executed in sub-active mode, operation transfers to sub-sleep mode or watch mode*.</li> </ul>
1	<ul style="list-style-type: none"> <li>When the SLEEP command is executed in high-speed mode or medium-speed mode, operation transfers directly to sub-active mode*, or transfers to sleep mode or software standby mode.</li> <li>When the SLEEP command is executed in sub-active mode*, operation transfers directly to high-speed mode or transfers to sub-sleep mode.</li> </ul>

Note: \* Always select high-speed mode when transferring to watch mode or sub-active mode.

Note: \*1 The H8S/2695 has no subclock function, so only a 0 may be written to this bit.

**BARA—Break Address Register A**  
**BARB—Break Address Register B**

**H'FE00**  
**H'FE04**

**PBC**  
**PBC**

Bit	:	31	...	24	23	22	21	20	19	18	17	16	...	7	6	5	4	3	2	1	0
		—	...	—	BAA 23	BAA 22	BAA 21	BAA 20	BAA 19	BAA 18	BAA 17	BAA 16	...	BAA 7	BAA 6	BAA 5	BAA 4	BAA 3	BAA 2	BAA 1	BAA 0
Initial value	:	Unde- fined	...	Unde- fined	0	0	0	0	0	0	0	0	...	0	0	0	0	0	0	0	0
R/W	:	—	...	—	R/W	R/W	R/W	R/W	R/W	R/W	R/W	R/W	...	R/W	R/W	R/W	R/W	R/W	R/W	R/W	R/W

Break address 23 to 0

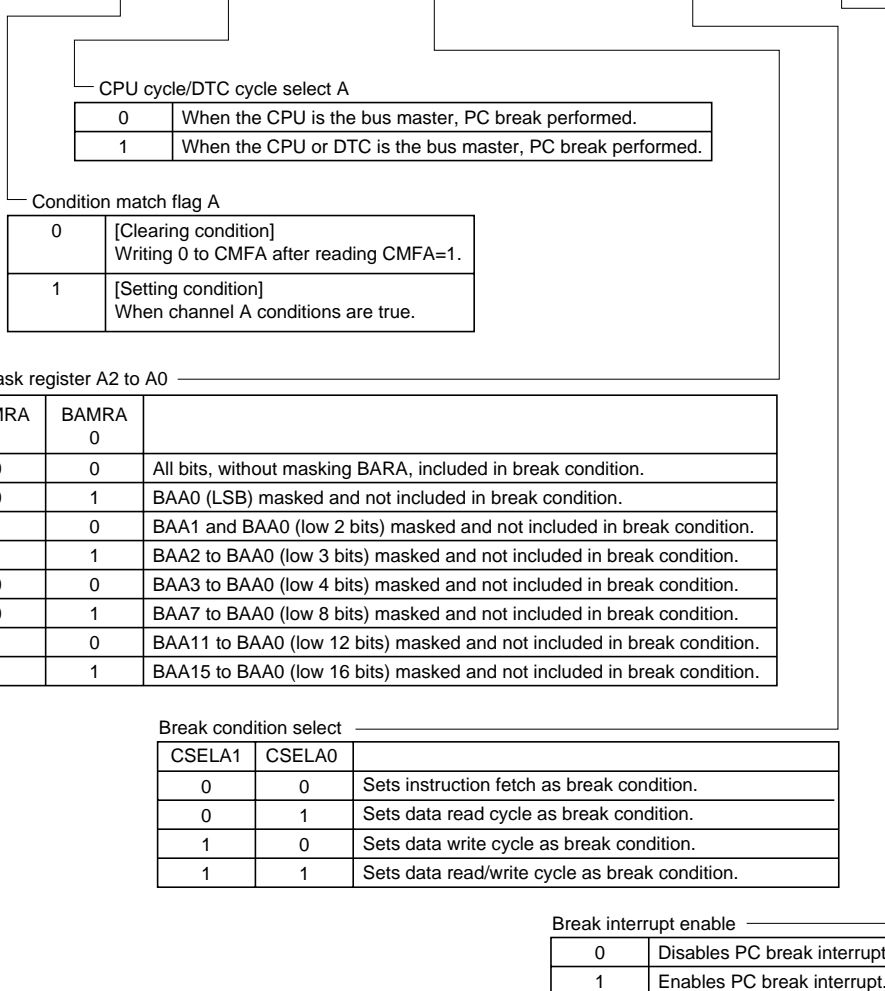
Note: The bit configuration of BARB is the same as that of BARA.

**BCRA—Break Control Register A**  
**BCRB—Break Control Register B**

**H'FE08**  
**H'FE09**

**PBC**  
**PBC**

Bit	:	7	6	5	4	3	2	1	0
		CMFA	CDA	BAMRA2	BAMRA1	BAMRA0	CSELA1	CSELA0	BIEA
Initial value	:	0	0	0	0	0	0	0	0
R/W	:	R/(W)*	R/W	R/W	R/W	R/W	R/W	R/W	R/W



Notes: The bit configuration of BCRB is the same as that of BCRA.  
 \* Only 0 can be written to these bits (to clear these flags).

**ISCRH—IRQ Sense Control Register H**  
**ISCR L—IRQ Sense Control Register L**

**H'FE12**  
**H'FE13**

**Interrupt Controller**  
**Interrupt Controller**

**ISCRH**

Bit	:	15	14	13	12	11	10	9	8
		IRQ7SCB	IRQ7SCA	IRQ6SCB	IRQ6SCA	IRQ5SCB	IRQ5SCA	IRQ4SCB	IRQ4SCA
Initial value	:	0	0	0	0	0	0	0	0
R/W	:	R/W	R/W	R/W	R/W	R/W	R/W	R/W	R/W

**ISCR L**

Bit	:	7	6	5	4	3	2	1	0
		IRQ3SCB	IRQ3SCA	IRQ2SCB	IRQ2SCA	IRQ1SCB	IRQ1SCA	IRQ0SCB	IRQ0SCA
Initial value	:	0	0	0	0	0	0	0	0
R/W	:	R/W	R/W	R/W	R/W	R/W	R/W	R/W	R/W

IRQ7 sense control A, B to  
 IRQ0 sense control A, B

IRQ7SCB to IRQ0SCB	IRQ7SCA to IRQ0SCA	
0	0	Interrupt request issued when $\overline{\text{IRQ7}}$ to $\overline{\text{IRQ0}}$ input level low.
	1	Interrupt request issued on falling edge of $\overline{\text{IRQ7}}$ to $\overline{\text{IRQ0}}$ input.
1	0	Interrupt request issued on rising edge of $\overline{\text{IRQ7}}$ to $\overline{\text{IRQ0}}$ input.
	1	Interrupt request issued on both falling and rising edge of $\overline{\text{IRQ7}}$ to $\overline{\text{IRQ0}}$ input.

**IER—IRQ Enable Register**

**H'FE14**

**Interrupt Controller**

Bit	:	7	6	5	4	3	2	1	0
		IRQ7E	IRQ6E	IRQ5E	IRQ4E	IRQ3E	IRQ2E	IRQ1E	IRQ0E
Initial value	:	0	0	0	0	0	0	0	0
R/W	:	R/W	R/W	R/W	R/W	R/W	R/W	R/W	R/W

IRQ7 to IRA0 enable

0	Disables IRQn interrupt.
1	Enables IRQn interrupt.

(n= 7 to 0)



ISR—IRQ Status Register

H'FE15

Interrupt Controller

Bit	:	7	6	5	4	3	2	1	0
		IRQ7F	IRQ6F	IRQ5F	IRQ4F	IRQ3F	IRQ2F	IRQ1F	IRQ0F
Initial value	:	0	0	0	0	0	0	0	0
R/W	:	R/(W)*	R/(W)*	R/(W)*	R/(W)*	R/(W)*	R/(W)*	R/(W)*	R/(W)*

IRQ7 to IRQ0 flag

0	<p>[Clearing]</p> <p>(1) Writing 0 to flag IRQnF after reading IRQnF=1;</p> <p>(2) When interrupt exception processing is executed when set for LOW-level detection (IRQnSCB=IRQnSCA=0) and, in addition, the <math>\overline{\text{IRQn}}</math> input level is HIGH;</p> <p>(3) When IRQn interrupt exception processing is executed when set for rising edge or falling edge or both rising edge and falling edge detection (IRQnSCB=1 and IRQnSCA=1);</p> <p>(4) When the DTC starts due to IRQn interrupt and the DTC MRB DISEL bit is 0.</p>
1	<p>[Setting]</p> <p>(1) When the <math>\overline{\text{IRQn}}</math> input level changes to LOW when set for LOW level detection (IRQnSCB=IRQnSCA=0);</p> <p>(2) When a falling edge occurs at the <math>\overline{\text{IRQn}}</math> input when set for falling edge detection (IRQnSCB=0, IRQnSCA=1);</p> <p>(3) When a rising edge occurs at the <math>\overline{\text{IRQn}}</math> input when set for rising edge detection (IRQnSCB=1, IRQnSCA=0);</p> <p>(4) When either a falling edge or rising edge occurs at the <math>\overline{\text{IRQn}}</math> input when set for both falling edge and rising edge detection (IRQnSCB=IRQnSCA=1).</p>

(n= 7 to 0)

Note: \* Only 0 can be written to these bits (to clear these flags).

**DTCER—DTC Enable Register**

**H'FE16  
to  
H'FE1E**

**DTC**

Bit	:	7	6	5	4	3	2	1	0
		DTCE7	DTCE6	DTCE5	DTCE4	DTCE3	DTCE2	DTCE1	DTCE0
Initial value	:	0	0	0	0	0	0	0	0
R/W	:	R/W	R/W	R/W	R/W	R/W	R/W	R/W	R/W

DTC start enable

DTCE <sub>n</sub>	
0	DTC startup by interrupt disabled [Clearing conditions] <ul style="list-style-type: none"> <li>• When data transmission ends with the DISEL bit =1.</li> <li>• On completion of the specified number of transmissions.</li> </ul>
1	DTC startup by interrupt enabled [Retention condition] When DISEL=0 and the specified number of transmissions has not completed.

(n= 7 to 0)

**DTVECR—DTC Vector Register**

**H'FE1F**

**DTC**

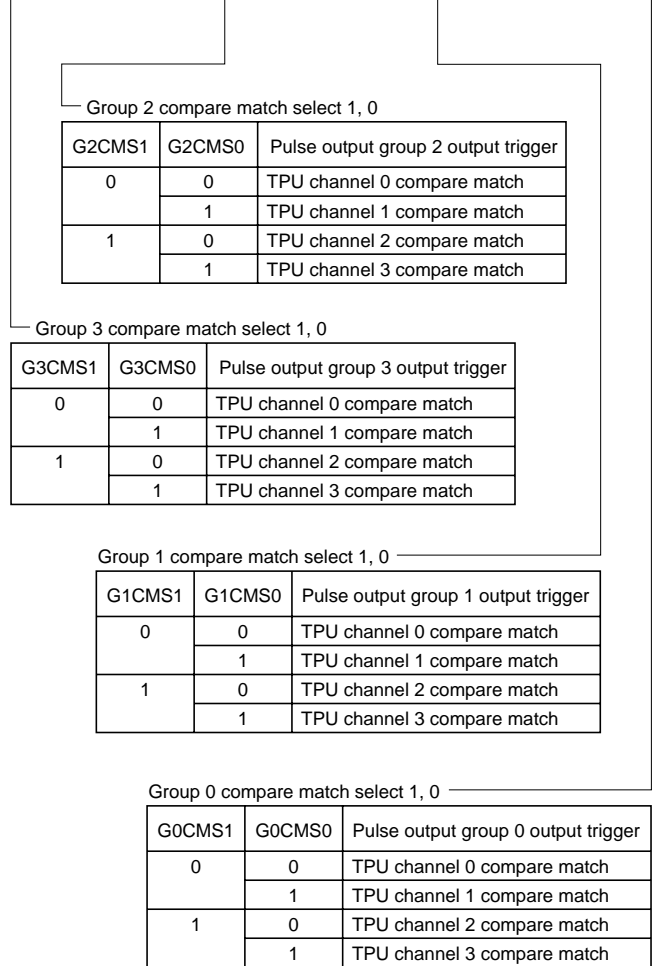
Bit	:	7	6	5	4	3	2	1	0
		SWDTE	DTVEC6	DTVEC5	DTVEC4	DTVEC3	DTVEC2	DTVEC1	DTVEC0
Initial value	:	0	0	0	0	0	0	0	0
R/W	:	R/(W)*1	R/(W)*2	R/(W)*2	R/(W)*2	R/(W)*2	R/(W)*2	R/(W)*2	R/(W)*2

DTC software startup enable	
0	DTC software startup disabled [Clearing conditions] • When DISEL=0 and the specified number of transmissions has not completed. • When 0 is written after a software startup data transmit end interrupt (SWDTEND) request is sent to the CPU.
1	DTC software startup enabled [Retention conditions] • When DISEL=1 and data transmission ends; • On completion of the specified number of transmissions; • During data transmission by software startup.

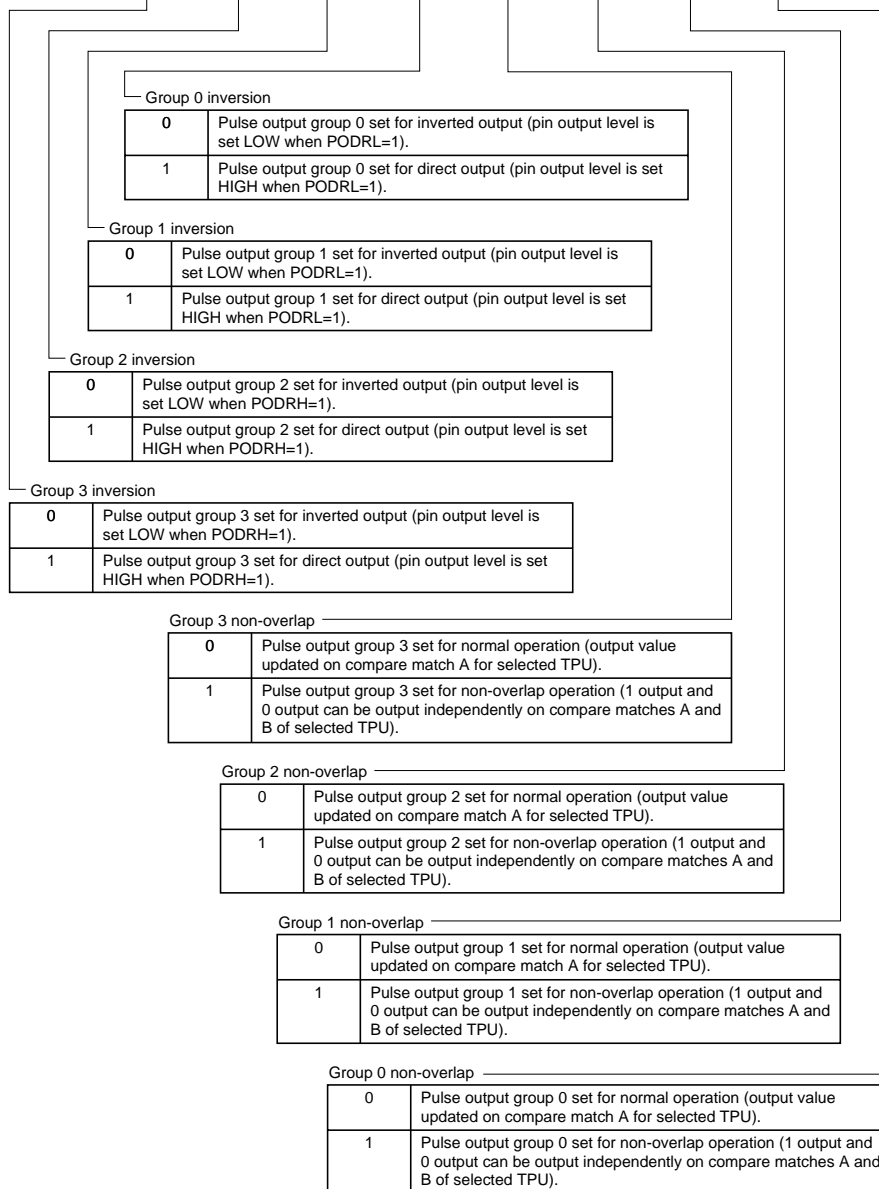
DTC software startup vector 6 to 0

- Notes: \*1 Only 1 can be written to the SWDTE bit.  
\*2 DTVEC6 to DTVEC0 can be written to when SWDTE=0.

Bit	:	7	6	5	4	3	2	1	0
		G3CMS1	G3CMS0	G2CMS1	G2CMS0	G1CMS1	G1CMS0	G0CMS1	G0CMS0
Initial value	:	1	1	1	1	1	1	1	1
R/W	:	R/W	R/W	R/W	R/W	R/W	R/W	R/W	R/W



Bit	:	7	6	5	4	3	2	1	0
		G3INV	G2INV	G1INV	G0INV	G3NOV	G2NOV	G1NOV	G0NOV
Initial value	:	1	1	1	1	0	0	0	0
R/W	:	R/W	R/W	R/W	R/W	R/W	R/W	R/W	R/W



**NDERH—Next Data Enable Register H**  
**NDERL—Next Data Enable Register L**

**H'FE28**  
**H'FE29**

**PPG**  
**PPG**

**NDERH**

Bit	:	7	6	5	4	3	2	1	0
		NDER15	NDER14	NDER13	NDER12	NDER11	NDER10	NDER9	NDER8
Initial value	:	0	0	0	0	0	0	0	0
R/W	:	R/W	R/W	R/W	R/W	R/W	R/W	R/W	R/W

Next data enable 15 to 8

NDER15 to NDER8	
0	Pulse output PO15 to PO8 disabled (transfer from NDR15-NDR8 to POD15-POD8 disabled).
1	Pulse output PO15 to PO8 enabled (transfer from NDR15-NDR8 to POD15-POD8 enabled).

**NDERL**

Bit	:	7	6	5	4	3	2	1	0
		NDER7	NDER6	NDER5	NDER4	NDER3	NDER2	NDER1	NDER0
Initial value	:	0	0	0	0	0	0	0	0
R/W	:	R/W	R/W	R/W	R/W	R/W	R/W	R/W	R/W

Next data enable 7 to 0

NDER7 to NDER0	
0	Pulse output PO7 to PO0 disabled (transfer from NDR7-NDR0 to POD7-POD0 disabled).
1	Pulse output PO7 to PO0 enabled (transfer from NDR7-NDR0 to POD7-POD0 enabled).

**PODRH—Output Data Register H**  
**PODRL—Output Data Register L**

**H'FE2A**  
**H'FE2B**

**PPG**  
**PPG**

**PODRH**

Bit	:	7	6	5	4	3	2	1	0
		POD15	POD14	POD13	POD12	POD11	POD10	POD9	POD8
Initial value	:	0	0	0	0	0	0	0	0
R/W	:	R/(W)*	R/(W)*	R/(W)*	R/(W)*	R/(W)*	R/(W)*	R/(W)*	R/(W)*

**PODRL**

Bit	:	7	6	5	4	3	2	1	0
		POD7	POD6	POD5	POD4	POD3	POD2	POD1	POD0
Initial value	:	0	0	0	0	0	0	0	0
R/W	:	R/(W)*	R/(W)*	R/(W)*	R/(W)*	R/(W)*	R/(W)*	R/(W)*	R/(W)*

Note: \* The bits set for pulse output by NDER are read-only bits.

Same trigger for pulse output groups.

Bit	:	7	6	5	4	3	2	1	0
		NDR15	NDR14	NDR13	NDR12	NDR11	NDR10	NDR9	NDR8
Initial value	:	0	0	0	0	0	0	0	0
R/W	:	R/W	R/W	R/W	R/W	R/W	R/W	R/W	R/W
Bit	:	7	6	5	4	3	2	1	0
		—	—	—	—	—	—	—	—
Initial value	:	1	1	1	1	1	1	1	1
R/W	:	—	—	—	—	—	—	—	—

Different triggers for pulse output groups.

Bit	:	7	6	5	4	3	2	1	0
		NDR15	NDR14	NDR13	NDR12	—	—	—	—
Initial value	:	0	0	0	0	1	1	1	1
R/W	:	R/W	R/W	R/W	R/W	—	—	—	—
Bit	:	7	6	5	4	3	2	1	0
		—	—	—	—	NDR11	NDR10	NDR9	NDR8
Initial value	:	1	1	1	1	0	0	0	0
R/W	:	—	—	—	—	R/W	R/W	R/W	R/W

Note: For details see section 12.2.4, Notes on NDR Access.



Same trigger for pulse output groups.

Bit	:	7	6	5	4	3	2	1	0
		NDR7	NDR6	NDR5	NDR4	NDR3	NDR2	NDR1	NDR0
Initial value	:	0	0	0	0	0	0	0	0
R/W	:	R/W	R/W	R/W	R/W	R/W	R/W	R/W	R/W
Bit	:	7	6	5	4	3	2	1	0
		—	—	—	—	—	—	—	—
Initial value	:	1	1	1	1	1	1	1	1
R/W	:	—	—	—	—	—	—	—	—

Different triggers for pulse output groups.

Bit	:	7	6	5	4	3	2	1	0
		NDR7	NDR6	NDR5	NDR4	—	—	—	—
Initial value	:	0	0	0	0	1	1	1	1
R/W	:	R/W	R/W	R/W	R/W	—	—	—	—
Bit	:	7	6	5	4	3	2	1	0
		—	—	—	—	NDR3	NDR2	NDR1	NDR0
Initial value	:	1	1	1	1	0	0	0	0
R/W	:	—	—	—	—	R/W	R/W	R/W	R/W

Note: For details see section 12.2.4, Notes on NDR Access.

**P1DDR—Port 1 Data Direction Register**

Bit	:	7	6	5	4	3	2	1	0
		P17DDR	P16DDR	P15DDR	P14DDR	P13DDR	P12DDR	P11DDR	P10DDR
Initial value	:	0	0	0	0	0	0	0	0
R/W	:	W	W	W	W	W	W	W	W

**P3DDR—Port 3 Data Direction Register** **H'FE32** **Port**

Bit	:	7	6	5	4	3	2	1	0
		P37DDR	P36DDR	P35DDR	P34DDR	P33DDR	P32DDR	P31DDR	P30DDR
Initial value	:	0	0	0	0	0	0	0	0
R/W	:	W	W	W	W	W	W	W	W

**P7DDR—Port 7 Data Direction Register** **H'FE36** **Port**

Bit	:	7	6	5	4	3	2	1	0
		P77DDR	P76DDR	P75DDR	P74DDR	P73DDR	P72DDR	P71DDR	P70DDR
Initial value	:	0	0	0	0	0	0	0	0
R/W	:	W	W	W	W	W	W	W	W

**PADDR—Port A Data Direction Register** **H'FE39** **Port**

Bit	:	7	6	5	4	3	2	1	0
		—	—	—	—	PA3DDR	PA2DDR	PA1DDR	PA0DDR
Initial value	:	Undefined	Undefined	Undefined	Undefined	0	0	0	0
R/W	:	—	—	—	—	W	W	W	W

**PBDDR—Port B Data Direction Register** **H'FE3A** **Port**

Bit	:	7	6	5	4	3	2	1	0
		PB7DDR	PB6DDR	PB5DDR	PB4DDR	PB3DDR	PB2DDR	PB1DDR	PB0DDR
Initial value	:	0	0	0	0	0	0	0	0
R/W	:	W	W	W	W	W	W	W	W

**PCDDR—Port C Data Direction Register** **H'FE3B** **Port**

Bit	:	7	6	5	4	3	2	1	0
		PC7DDR	PC6DDR	PC5DDR	PC4DDR	PC3DDR	PC2DDR	PC1DDR	PC0DDR
Initial value	:	0	0	0	0	0	0	0	0
R/W	:	W	W	W	W	W	W	W	W

**PDDDR—Port D Data Direction Register** **H'FE3C** **Port**

Bit	:	7	6	5	4	3	2	1	0								
		<table style="width: 100%; border-collapse: collapse;"> <tr> <td style="border: 1px solid black; padding: 2px;">PD7DDR</td> <td style="border: 1px solid black; padding: 2px;">PD6DDR</td> <td style="border: 1px solid black; padding: 2px;">PD5DDR</td> <td style="border: 1px solid black; padding: 2px;">PD4DDR</td> <td style="border: 1px solid black; padding: 2px;">PD3DDR</td> <td style="border: 1px solid black; padding: 2px;">PD2DDR</td> <td style="border: 1px solid black; padding: 2px;">PD1DDR</td> <td style="border: 1px solid black; padding: 2px;">PD0DDR</td> </tr> </table>								PD7DDR	PD6DDR	PD5DDR	PD4DDR	PD3DDR	PD2DDR	PD1DDR	PD0DDR
PD7DDR	PD6DDR	PD5DDR	PD4DDR	PD3DDR	PD2DDR	PD1DDR	PD0DDR										
Initial value	:	0	0	0	0	0	0	0	0								
R/W	:	W	W	W	W	W	W	W	W								

**PEDDR—Port E Data Direction Register** **H'FE3D** **Port**

Bit	:	7	6	5	4	3	2	1	0								
		<table style="width: 100%; border-collapse: collapse;"> <tr> <td style="border: 1px solid black; padding: 2px;">PE7DDR</td> <td style="border: 1px solid black; padding: 2px;">PE6DDR</td> <td style="border: 1px solid black; padding: 2px;">PE5DDR</td> <td style="border: 1px solid black; padding: 2px;">PE4DDR</td> <td style="border: 1px solid black; padding: 2px;">PE3DDR</td> <td style="border: 1px solid black; padding: 2px;">PE2DDR</td> <td style="border: 1px solid black; padding: 2px;">PE1DDR</td> <td style="border: 1px solid black; padding: 2px;">PE0DDR</td> </tr> </table>								PE7DDR	PE6DDR	PE5DDR	PE4DDR	PE3DDR	PE2DDR	PE1DDR	PE0DDR
PE7DDR	PE6DDR	PE5DDR	PE4DDR	PE3DDR	PE2DDR	PE1DDR	PE0DDR										
Initial value	:	0	0	0	0	0	0	0	0								
R/W	:	W	W	W	W	W	W	W	W								

**PFDDR—Port F Data Direction Register** **H'FE3E** **Port**

Bit	:	7	6	5	4	3	2	1	0								
		<table style="width: 100%; border-collapse: collapse;"> <tr> <td style="border: 1px solid black; padding: 2px;">PF7DDR</td> <td style="border: 1px solid black; padding: 2px;">PF6DDR</td> <td style="border: 1px solid black; padding: 2px;">PF5DDR</td> <td style="border: 1px solid black; padding: 2px;">PF4DDR</td> <td style="border: 1px solid black; padding: 2px;">PF3DDR</td> <td style="border: 1px solid black; padding: 2px;">PF2DDR</td> <td style="border: 1px solid black; padding: 2px;">PF1DDR</td> <td style="border: 1px solid black; padding: 2px;">PF0DDR</td> </tr> </table>								PF7DDR	PF6DDR	PF5DDR	PF4DDR	PF3DDR	PF2DDR	PF1DDR	PF0DDR
PF7DDR	PF6DDR	PF5DDR	PF4DDR	PF3DDR	PF2DDR	PF1DDR	PF0DDR										
Modes 4 to 6																	
Initial value	:	1	0	0	0	0	0	0	0								
R/W	:	W	W	W	W	W	W	W	W								
Mode 7																	
Initial value	:	0	0	0	0	0	0	0	0								
R/W	:	W	W	W	W	W	W	W	W								

**PGDDR—Port G Data Direction Register** **H'FE3F** **Port**

Bit	:	7	6	5	4	3	2	1	0
		—	—	—	PG4DDR	PG3DDR	PG2DDR	PG1DDR	PG0DDR
Modes 4 and 5									
Initial value	:	Undefined	Undefined	Undefined	1	0	0	0	0
R/W	:	—	—	—	W	W	W	W	W
Modes 6 and 7									
Initial value	:	Undefined	Undefined	Undefined	0	0	0	0	0
R/W	:	—	—	—	W	W	W	W	W

**PAPCR—Port A Pull-Up MOS Control Register** **H'FE40** **Port**

Bit	:	7	6	5	4	3	2	1	0
		—	—	—	—	PA3PCR	PA2PCR	PA1PCR	PA0PCR
Initial value	:	Undefined	Undefined	Undefined	Undefined	0	0	0	0
R/W	:	—	—	—	—	R/W	R/W	R/W	R/W

**PBPCR—Port B Pull-Up MOS Control Register** **H'FE41** **Port**

Bit	:	7	6	5	4	3	2	1	0
		PB7PCR	PB6PCR	PB5PCR	PB4PCR	PB3PCR	PB2PCR	PB1PCR	PB0PCR
Initial value	:	0	0	0	0	0	0	0	0
R/W	:	R/W	R/W	R/W	R/W	R/W	R/W	R/W	R/W

**PCPCR—Port C Pull-Up MOS Control Register** **H'FE42** **Port**

Bit	:	7	6	5	4	3	2	1	0
		PC7PCR	PC6PCR	PC5PCR	PC4PCR	PC3PCR	PC2PCR	PC1PCR	PC0PCR
Initial value	:	0	0	0	0	0	0	0	0
R/W	:	R/W	R/W	R/W	R/W	R/W	R/W	R/W	R/W

**PDPCR—Port D Pull-Up MOS Control Register      H'FE43      Port**

Bit	:	7	6	5	4	3	2	1	0
		PD7PCR	PD6PCR	PD5PCR	PD4PCR	PD3PCR	PD2PCR	PD1PCR	PD0PCR
Initial value :		0	0	0	0	0	0	0	0
R/W	:	R/W	R/W	R/W	R/W	R/W	R/W	R/W	R/W

**PEPCR—Port E Pull-Up MOS Control Register      H'FE44      Port**

Bit	:	7	6	5	4	3	2	1	0
		PE7PCR	PE6PCR	PE5PCR	PE4PCR	PE3PCR	PE2PCR	PE1PCR	PE0PCR
Initial value :		0	0	0	0	0	0	0	0
R/W	:	R/W	R/W	R/W	R/W	R/W	R/W	R/W	R/W

**P3ODR—Port 3 Open-Drain Control Register      H'FE46      Port**

Bit	:	7	6	5	4	3	2	1	0
		P37ODR	P36ODR	P35ODR	P34ODR	P33ODR	P32ODR	P31ODR	P30ODR
Initial value :		0	0	0	0	0	0	0	0
R/W	:	R/W	R/W	R/W	R/W	R/W	R/W	R/W	R/W

**PAODR—Port A Open Drain Control Register      H'FE47      Port**

Bit	:	7	6	5	4	3	2	1	0
		—	—	—	—	PA3ODR	PA2ODR	PA1ODR	PA0ODR
Initial value :		Undefined	Undefined	Undefined	Undefined	0	0	0	0
R/W	:	—	—	—	—	R/W	R/W	R/W	R/W

**PBODR—Port B Open Drain Control Register**                      **H'FE48**                      **Port**

Bit	:	7	6	5	4	3	2	1	0
		PB7ODR	PB6ODR	PB5ODR	PB4ODR	PB3ODR	PB2ODR	PB1ODR	PB0ODR
Initial value :		0	0	0	0	0	0	0	0
R/W	:	R/W	R/W	R/W	R/W	R/W	R/W	R/W	R/W

**PCODR—Port C Open Drain Control Register**                      **H'FE49**                      **Port**

Bit	:	7	6	5	4	3	2	1	0
		PC7ODR	PC6ODR	PC5ODR	PC4ODR	PC3ODR	PC2ODR	PC1ODR	PC0ODR
Initial value :		0	0	0	0	0	0	0	0
R/W	:	R/W	R/W	R/W	R/W	R/W	R/W	R/W	R/W

**TCR0—Timer Control Register 0**  
**TCR3—Timer Control Register 3**

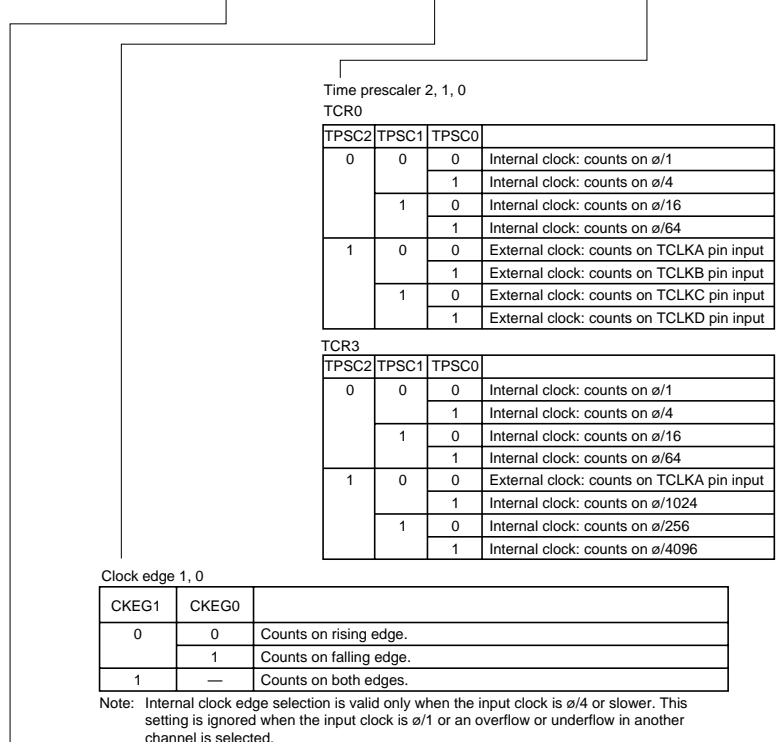
**H'FF10**  
**H'FE80**

**TPU0**  
**TPU3**

Channel 0: TCR0

Channel 3: TCR3

Bit	:	7	6	5	4	3	2	1	0
		CCLR2	CCLR1	CCLR0	CKEG1	CKEG0	TPSC2	TPSC1	TPSC0
Initial value :		0	0	0	0	0	0	0	0
R/W	:	R/W	R/W	R/W	R/W	R/W	R/W	R/W	R/W



Counter clear 2, 1, 0

CCLR2	CCLR1	CCLR0	
0	0	0	TCNT clearing disabled.
		1	TCNT cleared at TGRA compare match/input capture.
	1	0	TCNT cleared at TGRB compare match/input capture.
		1	TCNT cleared when other channel counters with synchronized clearing or synchronized operation are cleared.*1
1	0	0	TCNT clearing disabled.
		1	TCNT cleared at TGRC compare match/input capture.*2
	1	0	TCNT cleared at TGRD compare match/input capture.*2
		1	TCNT cleared when other channel counters with synchronized clearing or synchronized operation are cleared.*1

Notes: \*1 Synchronous operation setting is performed by setting the SYNC bit in TSYR to 1.  
\*2 When TGRC or TGRD is used as a buffer register, TCNT is not cleared because the buffer register setting has priority, and compare match/input capture does not occur.

**TMDR0—Timer Mode Register 0**  
**TMDR3—Timer Mode Register 3**

**H'FF11**  
**H'FE81**

**TPU0**  
**TPU3**

Channel 0: TMDR0

Channel 3: TMDR3

Bit	:	7	6	5	4	3	2	1	0
		—	—	BFB	BFA	MD3	MD2	MD1	MD0
Initial value	:	1	1	0	0	0	0	0	0
R/W	:	—	—	R/W	R/W	R/W	R/W	R/W	R/W

Buffer operation B

0	Normal TGRB operation.
1	Buffer operation of TGRB and TGRD.

Buffer operation A

0	Normal TGRA operation.
1	Buffer operation of TGRA and TGRC.

Modes 3 to 0

MD3 <sup>*1</sup>	MD2 <sup>*2</sup>	MD1	MD0		
0	0	0	0	Normal operation	
			1	Reserved	
		1	0	PWM mode 1	
			1	PWM mode 2	
	1	0	0	0	Phase calculation mode 1
				1	Phase calculation mode 2
		1	0	0	Phase calculation mode 3
				1	Phase calculation mode 4
1	*	*	*	—	

\* : Don't care

Notes: \*1 MD3 is a reserved bit. Only write 0 to this bit.

\*2 Phase calculation mode cannot be set for channels 0 and 3.  
 Only write 0 to MD2.



Bit	:	7	6	5	4	3	2	1	0
		IOB3	IOB2	IOB1	IOB0	IOA3	IOA2	IOA1	IOA0
Initial value:		0	0	0	0	0	0	0	0
R/W	:	R/W	R/W	R/W	R/W	R/W	R/W	R/W	R/W

TGR3A I/O Control						
0	0	0	0	TGR3A is output compare register	Output disabled	
			1		Initial output is 0 output	0 output at compare match
			1		1 output at compare match	
	1	0	0		Output disabled	
			1		Initial output is 1 output	0 output at compare match
			1		1 output at compare match	
1	0	0	0	TGR3A is input capture register	Input capture at rising edge	
			1		Input capture at falling edge	
	1	*	*		1	Input capture at both edges
					1	Input capture at TCNT4 count-up/ count-down

\*: Don't care

TGR3B I/O Control

0	0	0	0	TGR3B is output compare register	Output disabled		
			1		Initial output is 0 output	0 output at compare match	
			1		1 output at compare match		
	1	0	0		0	Output disabled	
					1	Initial output is 1 output	0 output at compare match
					1	1 output at compare match	
1	0	0	0	TGR3B is input capture register	Input capture at rising edge		
			1		Input capture at falling edge		
	1	*	*		1	Input capture at both edges	
					1	Input capture at TCNT4 count-up/ count-down*1	

\*: Don't care

Note: \*1 When bits TPSC2 to TPSC0 in TCR4 are set to B'000 and 0/1 is used as the TCNT4 count clock, this setting is invalid and input capture is not generated.

**TIOR4—Timer I/O Control Register 4**

**H'FE92**

**TPU4**

Bit	:	7	6	5	4	3	2	1	0
		IOB3	IOB2	IOB1	IOB0	IOA3	IOA2	IOA1	IOA0
Initial value :		0	0	0	0	0	0	0	0
R/W	:	R/W	R/W	R/W	R/W	R/W	R/W	R/W	R/W

0	0	0	0	TGR4A is output compare register	Output disabled				
					1	0	Initial output is 0 output	0 output at compare match	
							1 output at compare match	Toggle output at compare match	
		1	0		0	Output disabled			
						1	0	Initial output is 1 output	0 output at compare match
								1 output at compare match	Toggle output at compare match
	1	0	0	TGR4A is input capture register	Capture input source is TIOCA4 pin				
					1	0	Input capture at rising edge	Input capture at falling edge	
							1	*	Input capture at both edges
		1	*		*	Capture input source is TGR3A compare match/ input capture	Input capture at generation of TGR3A compare match/input capture		

\*: Don't care

TGR4B I/O Control

0	0	0	TGR4B is output compare register	Output disabled					
				1	0	Initial output is 0 output	0 output at compare match		
						1 output at compare match	Toggle output at compare match		
		1		0	0	Output disabled			
						1	0	Initial output is 1 output	0 output at compare match
								1 output at compare match	Toggle output at compare match
	1	0	0	TGR4B is input capture register	Capture input source is TIOCB4 pin				
					1	0	Input capture at rising edge	Input capture at falling edge	
							1	*	Input capture at both edges
		1	*		*	Capture input source is TGR3C compare match/ input capture	Input capture at generation of TGR3C compare match/input capture		

\*: Don't care

**TIOR5—Timer I/O Control Register 5**

**H'FEA2**

**TPU5**

Bit	:	7	6	5	4	3	2	1	0
		IOB3	IOB2	IOB1	IOB0	IOA3	IOA2	IOA1	IOA0
Initial value:		0	0	0	0	0	0	0	0
R/W	:	R/W	R/W	R/W	R/W	R/W	R/W	R/W	R/W

TGR5A I/O Control							
0	0	0	0	TGR5A is output compare register	Output disabled		
			1		Initial output is 0 output	0 output at compare match	
			0			1 output at compare match	
	1	Toggle output at compare match					
	1	0	0		1	Output disabled	
					1	Initial output is 1 output	0 output at compare match
0				1 output at compare match			
1	Toggle output at compare match						
1	*	0	0	TGR5A is input capture register	Capture input source is TIOCA5 pin	Input capture at rising edge	
			1			Input capture at falling edge	
			*			Input capture at both edges	

\*: Don't care

TGR5B I/O Control

0	0	0	0	TGR5B is output compare register	Output disabled		
			1		Initial output is 0 output	0 output at compare match	
			0			1 output at compare match	
	1	Toggle output at compare match					
	1	0	0		1	Output disabled	
					1	Initial output is 1 output	0 output at compare match
0				1 output at compare match			
1	Toggle output at compare match						
1	*	0	0	TGR5B is input capture register	Capture input source is TIOCB5 pin	Input capture at rising edge	
			1			Input capture at falling edge	
			*			Input capture at both edges	

\*: Don't care

**TIOR0H—Timer I/O Control Register 0H**

**H'FF12**

**TPU0**

Bit	:	7	6	5	4	3	2	1	0
		IOB3	IOB2	IOB1	IOB0	IOA3	IOA2	IOA1	IOA0
Initial value :		0	0	0	0	0	0	0	0
R/W	:	R/W	R/W	R/W	R/W	R/W	R/W	R/W	R/W

TGR0A I/O Control												
0	0	0	0	0	TGR0A is output compare register	Output disabled						
						1	0	0	0	Initial output is 0 output	0 output at compare match	
						1	0	1	0	1 output at compare match	Toggle output at compare match	
		1	0	0		0	Output disabled					
							1	0	0	0	Initial output is 1 output	0 output at compare match
							1	0	1	0	1 output at compare match	Toggle output at compare match
	1	0	0	0	TGR0A is input capture register	Capture input source is TIOCA0 pin						
						1	0	0	0	Input capture at rising edge		
						1	0	1	0	Input capture at falling edge		
		1	*	*		0	Capture input source is channel 1/count clock					
							1	0	0	0	Input capture at both edges	
							1	0	1	0	Input capture at TCNT1 count-up/count-down	

\*: Don't care

**TGR0B I/O Control**

0	0	0	0	TGR0B is output compare register	Output disabled							
					1	0	0	0	Initial output is 0 output	0 output at compare match		
					1	0	1	0	1 output at compare match	Toggle output at compare match		
		1	0		0	0	Output disabled					
							1	0	0	0	Initial output is 1 output	0 output at compare match
							1	0	1	0	1 output at compare match	Toggle output at compare match
	1	0	0	0	TGR0B is input capture register	Capture input source is TIOCB0 pin						
						1	0	0	0	Input capture at rising edge		
						1	0	1	0	Input capture at falling edge		
		1	*	*		0	Capture input source is channel 1/count clock					
							1	0	0	0	Input capture at both edges	
							1	0	1	0	Input capture at TCNT1 count-up/count-down*1	

\*: Don't care

Note: \*1 When bits TPSC2 to TPSC0 in TCR1 are set to B'000 and 0/1 is used as the TCNT1 count clock, this setting is invalid and input capture is not generated.

**TIOR1—Timer I/O Control Register 1**

**H'FF22**

**TPU1**

Bit	:	7	6	5	4	3	2	1	0
		IOB3	IOB2	IOB1	IOB0	IOA3	IOA2	IOA1	IOA0
Initial value :		0	0	0	0	0	0	0	0
R/W	:	R/W	R/W	R/W	R/W	R/W	R/W	R/W	R/W

TGR1A I/O Control						
0	0	0	0	TGR1A is output compare register	Output disabled	
			1		Initial output is 0 output	0 output at compare match
			0			1 output at compare match
	1	Toggle output at compare match				
	1	0	0		0	Output disabled
					1	Initial output is 1 output
0				1 output at compare match		
1	Toggle output at compare match					
1	0	0	0	TGR1A is input capture register	Capture input source is TIOCA1 pin	Input capture at rising edge
			1			Input capture at falling edge
			*			Input capture at both edges
	1	* * *	Capture input source is TGR0A compare match/ input capture		Input capture at generation of channel 0/TGR0A compare match/ input capture	

\*: Don't care

TGR1B I/O Control

0	0	0	0	TGR1B is output compare register	Output disabled	
			1		Initial output is 0 output	0 output at compare match
			0			1 output at compare match
	1	Toggle output at compare match				
	1	0	0		0	Output disabled
					1	Initial output is 1 output
0				1 output at compare match		
1	Toggle output at compare match					
1	0	0	0	TGR1B is input capture register	Capture input source is TIOCB1 pin	Input capture at rising edge
			1			Input capture at falling edge
			*			Input capture at both edges
	1	* * *	Capture input source is TGR0C compare match/ input capture		Input capture at generation of TGR0C compare match/ input capture	

\*: Don't care

**TIOR2—Timer I/O Control Register 2**

**H'FF32**

**TPU2**

Bit	:	7	6	5	4	3	2	1	0
		IOB3	IOB2	IOB1	IOB0	IOA3	IOA2	IOA1	IOA0
Initial value :		0	0	0	0	0	0	0	0
R/W	:	R/W	R/W	R/W	R/W	R/W	R/W	R/W	R/W

TGR2A I/O Control

0	0	0	0	TGR2A is output compare register	Output disabled			
			1		Initial output is 0 output	0 output at compare match		
			0			1 output at compare match		
		1	Toggle output at compare match					
		1	0		0	TGR2A is input capture register	Output disabled	
					1		Initial output is 1 output	0 output at compare match
	0			1 output at compare match				
	1	*	0	0	TGR2A is input capture register	Capture input source is TIOCA2 pin	Input capture at rising edge	
			1	*		Input capture at falling edge		
			1	*		Input capture at both edges		

\*: Don't care

TGR2B I/O Control

0	0	0	0	TGR2B is output compare register	Output disabled			
			1		Initial output is 0 output	0 output at compare match		
			0			1 output at compare match		
		1	Toggle output at compare match					
		1	0		0	TGR2B is input capture register	Output disabled	
					1		Initial output is 1 output	0 output at compare match
	0			1 output at compare match				
	1	*	0	0	TGR2B is input capture register	Capture input source is TIOCB2 pin	Input capture at rising edge	
			1	*		Input capture at falling edge		
			1	*		Input capture at both edges		

\*: Don't care

Bit	:	7	6	5	4	3	2	1	0
		IOD3	IOD2	IOD1	IOD0	IOC3	IOC2	IOC1	IOC0
Initial value:		0	0	0	0	0	0	0	0
R/W	:	R/W	R/W	R/W	R/W	R/W	R/W	R/W	R/W

0	0	0	0	TGR3C is output compare register*1	Output disabled				
					1	0	Initial output is 0 output	0 output at compare match	
					1	1	1 output at compare match	Toggle output at compare match	
		1	0		0	Output disabled			
						1	0	Initial output is 1 output	0 output at compare match
						1	1	1 output at compare match	Toggle output at compare match
	1	0	0	TGR3C is input capture register*1	Capture input source is TIOCC3 pin				
					1	0	Input capture at rising edge	Input capture at falling edge	
					1	1	Input capture at both edges		
		1	*		*	Capture input source is channel 4/count clock			
						Input capture at TCNT4 count-up/count-down			

\*: Don't care

Note: \*1 When the BFA bit in TMDR3 is set to 1 and TGR3C is used as a buffer register, this setting is invalid and input capture/output compare is not generated.

TGR3D I/O Control

0	0	0	TGR3D is output compare register*2	Output disabled					
				1	0	Initial output is 0 output	0 output at compare match		
				1	1	1 output at compare match	Toggle output at compare match		
		1		0	0	Output disabled			
						1	0	Initial output is 1 output	0 output at compare match
						1	1	1 output at compare match	Toggle output at compare match
	1	0	0	TGR3D is input capture register*2	Capture input source is TIOCD3 pin				
					1	0	Input capture at rising edge	Input capture at falling edge	
					1	1	Input capture at both edges		
		1	*		*	Capture input source is channel 4/count clock			
						Input capture at TCNT4 count-up/count-down*1			

\*: Don't care

Notes: \*1 When bits TPSC2 to TPSC0 in TCR4 are set to B'000 and ø/1 is used as the TCNT4 count clock, this setting is invalid and input capture is not generated.

\*2 When the BFB bit in TMDR3 is set to 1 and TGR3D is used as a buffer register, this setting is invalid and input capture/output compare is not generated.

Note: When TGRC or TGRD is designated for buffer operation, this setting is invalid and the register operates as a buffer register.

Bit	:	7	6	5	4	3	2	1	0
		IOD3	IOD2	IOD1	IOD0	IOC3	IOC2	IOC1	IOC0
Initial value:		0	0	0	0	0	0	0	0
R/W	:	R/W	R/W	R/W	R/W	R/W	R/W	R/W	R/W

0	0	0	0	0	TGR0C is output compare register*1	Output disabled		
						Initial output is 0 output	0 output at compare match	
							1 output at compare match	
						Toggle output at compare match		
	1	0	0	0	1	Output disabled		
						Initial output is 1 output	0 output at compare match	
							1 output at compare match	
						Toggle output at compare match		
	1	0	0	0	1	TGR0C is input capture register*1	Capture input source is TIOCC0 pin	
							Input capture at rising edge	
							Input capture at falling edge	
							Input capture at both edges	
1	*	*	*	1	*	Capture input source is channel 1/count clock		
						Input capture at TCNT1 count-up/count-down		

\*: Don't care

Note: \*1 When the BFA bit in TMDR0 is set to 1 and TGR0C is used as a buffer register, this setting is invalid and input capture/output compare is not generated.

TGR0D I/O Control

0	0	0	0	0	TGR0D is output compare register*2	Output disabled		
						Initial output is 0 output	0 output at compare match	
							1 output at compare match	
						Toggle output at compare match		
	1	0	0	0	1	Output disabled		
						Initial output is 1 output	0 output at compare match	
							1 output at compare match	
						Toggle output at compare match		
	1	0	0	0	1	TGR0D is input capture register*2	Capture input source is TIOCD0 pin	
							Input capture at rising edge	
							Input capture at falling edge	
							Input capture at both edges	
1	*	*	*	1	*	Capture input source is channel 1/count clock		
						Input capture at TCNT1 count-up/count-down*1		

\*: Don't care

Notes: \*1 When bits TPSC2 to TPSC0 in TCR1 are set to B'000 and 0/1 is used as the TCNT1 count clock, this setting is invalid and input capture is not generated.  
 \*2 When the BFB bit in TMDR0 is set to 1 and TGR0D is used as a buffer register, this setting is invalid and input capture/output compare is not generated.

Note: When TGRC or TGRD is designated for buffer operation, this setting is invalid and the register operates as a buffer register.



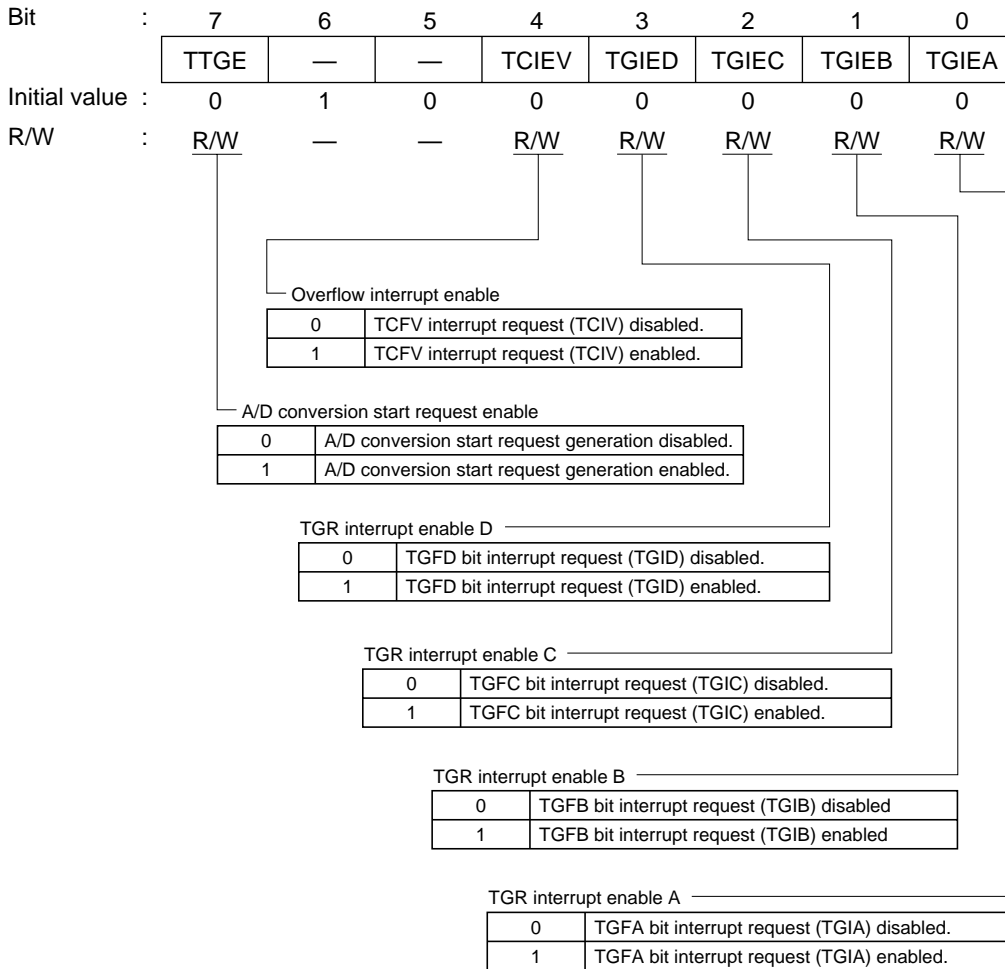
**TIER0—Timer Interrupt Enable Register 0**  
**TIER3—Timer Interrupt Enable Register 3**

**H'FF14**  
**H'FE84**

**TPU0**  
**TPU3**

Channel 0: TIER0

Channel 3: TIER3



**TSR0—Timer Status Register 0**  
**TSR3—Timer Status Register 3**

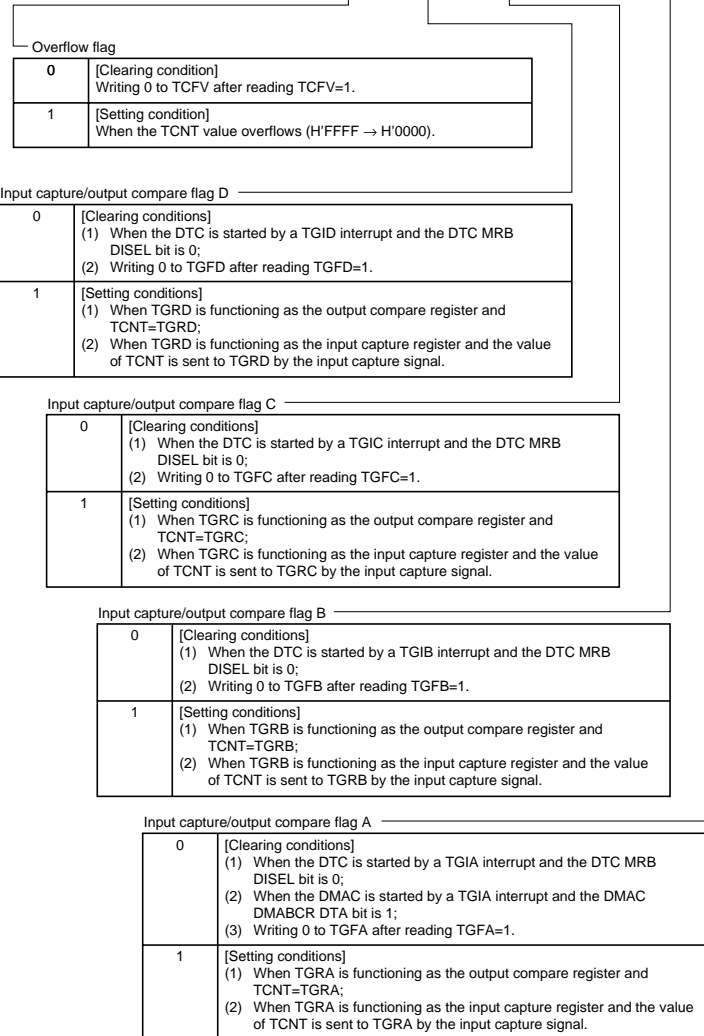
**H'FF15**  
**H'FE85**

**TPU0**  
**TPU3**

Channel 0: TSR0

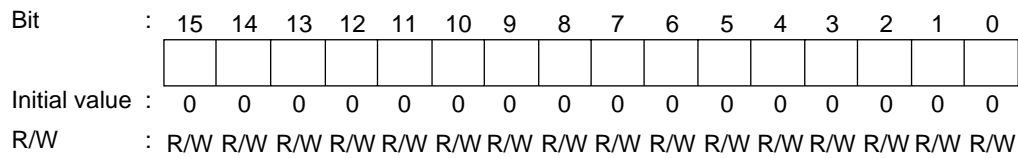
Channel 3: TSR3

Bit	:	7	6	5	4	3	2	1	0
		—	—	—	TCFV	TGFD	TGFC	TGFB	TGFA
Initial value	:	1	1	0	0	0	0	0	0
R/W	:	—	—	—	R/(W)*	R/(W)*	R/(W)*	R/(W)*	R/(W)*



Note: \* Only 0 can be written to these bits (to clear these flags).

<b>TCNT0—Timer Counter 0</b>	<b>H'FF16</b>	<b>TPU0</b>
<b>TCNT1*—Timer Counter 1</b>	<b>H'FF26</b>	<b>TPU1</b>
<b>TCNT2*—Timer Counter 2</b>	<b>H'FF36</b>	<b>TPU2</b>
<b>TCNT3—Timer Counter 3</b>	<b>H'FE86</b>	<b>TPU3</b>
<b>TCNT4*—Timer Counter 4</b>	<b>H'FE96</b>	<b>TPU4</b>
<b>TCNT5*—Timer Counter 5</b>	<b>H'FEA6</b>	<b>TPU5</b>



Note: \* This register can be used as an up/down counter only in phase calculation mode (and when counting overflows and underflows in other channels in phase calculation mode)  
 In all other cases, this register functions as an up-counter.

<b>TGR0A—Timer General Register 0A</b>	<b>H'FF18</b>	<b>TPU0</b>
<b>TGR0B—Timer General Register 0B</b>	<b>H'FF1A</b>	<b>TPU0</b>
<b>TGR0C—Timer General Register 0C</b>	<b>H'FF1C</b>	<b>TPU0</b>
<b>TGR0D—Timer General Register 0D</b>	<b>H'FF1E</b>	<b>TPU0</b>
<b>TGR1A—Timer General Register 1A</b>	<b>H'FF28</b>	<b>TPU1</b>
<b>TGR1B—Timer General Register 1B</b>	<b>H'FF2A</b>	<b>TPU1</b>
<b>TGR2A—Timer General Register 2A</b>	<b>H'FF38</b>	<b>TPU2</b>
<b>TGR2B—Timer General Register 2B</b>	<b>H'FF3A</b>	<b>TPU2</b>
<b>TGR3A—Timer General Register 3A</b>	<b>H'FE88</b>	<b>TPU3</b>
<b>TGR3B—Timer General Register 3B</b>	<b>H'FE8A</b>	<b>TPU3</b>
<b>TGR3C—Timer General Register 3C</b>	<b>H'FE8C</b>	<b>TPU3</b>
<b>TGR3D—Timer General Register 3D</b>	<b>H'FE8E</b>	<b>TPU3</b>
<b>TGR4A—Timer General Register 4A</b>	<b>H'FE98</b>	<b>TPU4</b>
<b>TGR4B—Timer General Register 4B</b>	<b>H'FE9A</b>	<b>TPU4</b>
<b>TGR5A—Timer General Register 5A</b>	<b>H'FEA8</b>	<b>TPU5</b>
<b>TGR5B—Timer General Register 5B</b>	<b>H'FEAA</b>	<b>TPU5</b>



TCR1—Timer Control Register 1  
 TCR2—Timer Control Register 2  
 TCR4—Timer Control Register 4  
 TCR5—Timer Control Register 5

H'FF20  
 H'FF30  
 H'FE90  
 H'FEA0

TPU1  
 TPU2  
 TPU4  
 TPU5

Channel 1: TCR1  
 Channel 2: TCR2  
 Channel 4: TCR4  
 Channel 5: TCR5

Bit	7	6	5	4	3	2	1	0
	—	CCLR1	CCLR0	CKEG1	CKEG0	TPSC2	TPSC1	TPSC0
Initial value	0	0	0	0	0	0	0	0
R/W	—	R/W	R/W	R/W	R/W	R/W	R/W	R/W

Time prescaler 2, 1, 0

TCR1			
0	0	0	Internal clock: counts on $\alpha/1$
	1	1	Internal clock: counts on $\alpha/4$
1	0	0	Internal clock: counts on $\alpha/16$
	1	1	Internal clock: counts on $\alpha/64$
1	0	0	External clock: counts on TCLKA pin input
	1	1	External clock: counts on TCLKB pin input
	0	0	Internal clock: counts on $\alpha/256$
	1	1	Counts on TCNT2 overflow/underflow

Note: This setting is ignored when channel 1 is in phase counting mode.

TCR2			
0	0	0	Internal clock: counts on $\alpha/1$
	1	1	Internal clock: counts on $\alpha/4$
1	0	0	Internal clock: counts on $\alpha/16$
	1	1	Internal clock: counts on $\alpha/64$
1	0	0	External clock: counts on TCLKA pin input
	1	1	External clock: counts on TCLKB pin input
	0	0	External clock: counts on TCLKC pin input
	1	1	Internal clock: counts on $\alpha/1024$

Note: This setting is ignored when channel 2 is in phase counting mode.

TCR4			
0	0	0	Internal clock: counts on $\alpha/1$
	1	1	Internal clock: counts on $\alpha/4$
1	0	0	Internal clock: counts on $\alpha/16$
	1	1	Internal clock: counts on $\alpha/64$
1	0	0	External clock: counts on TCLKA pin input
	1	1	External clock: counts on TCLKC pin input
	0	0	Internal clock: counts on $\alpha/1024$
	1	1	Counts on TCNT5 overflow/underflow

Note: This setting is ignored when channel 4 is in phase counting mode.

TCR5			
0	0	0	Internal clock: counts on $\alpha/1$
	1	1	Internal clock: counts on $\alpha/4$
1	0	0	Internal clock: counts on $\alpha/16$
	1	1	Internal clock: counts on $\alpha/64$
1	0	0	External clock: counts on TCLKA pin input
	1	1	External clock: counts on TCLKC pin input
	0	0	Internal clock: counts on $\alpha/256$
	1	1	External clock: counts on TCLKD pin input

Note: This setting is ignored when channel 5 is in phase counting mode.

Clock edge 1, 0

CKEG1	CKEG0	
0	0	Counts on rising edge.
1	1	Counts on falling edge.
1	—	Counts on both edges.

Note: Internal clock edge selection is valid only when the input clock is  $\alpha/4$  or slower. This setting is ignored when the input clock is  $\alpha/1$  or an overflow or underflow in another channel is selected.

Counter clear 2, 1, 0

Reserve*2	CCLR1	CCLR0	
0	0	0	TCNT clearing disabled.
		1	TCNT cleared at TGRA compare match/input capture.
	1	0	TCNT cleared at TGRB compare match/input capture.
		1	TCNT cleared when other channel counters with synchronized clearing or synchronized operation are cleared.*1

Notes: \*1 Sync operation is selected by setting 1 in the TSYR SYNC bit.

\*2 Bit 7 of channels 1, 2, 4, and 5 is reserved. This bit always returns 0 when read, and cannot be written to.

<b>TMDR1—Timer Mode Register 1</b>	<b>H'FF21</b>	<b>TPU1</b>
<b>TMDR2—Timer Mode Register 2</b>	<b>H'FF31</b>	<b>TPU2</b>
<b>TMDR4—Timer Mode Register 4</b>	<b>H'FE91</b>	<b>TPU4</b>
<b>TMDR5—Timer Mode Register 5</b>	<b>H'FEA1</b>	<b>TPU5</b>

Channel 1: TMDR1

Channel 2: TMDR2

Channel 4: TMDR4

Channel 5: TMDR5

Bit	:	7	6	5	4	3	2	1	0
		—	—	—	—	MD3	MD2	MD1	MD0
Initial value	:	1	1	0	0	0	0	0	0
R/W	:	—	—	—	—	R/W	R/W	R/W	R/W

Modes 3 to 0

MD3*1	MD2*2	MD1	MD0		
0	0	0	0	Normal operation	
			1	Reserved	
		1	0	PWM mode 1	
			1	PWM mode 2	
	1	0	0	0	Phase calculation mode 1
				1	Phase calculation mode 2
		1	0	0	Phase calculation mode 3
				1	Phase calculation mode 4
1	*	*	*	—	

\* : Don't care

Notes: \*1 MD3 is a reserved bit. Only write 0 to this bit.

\*2 Phase calculation mode cannot be set for channels 0 and 3.  
Only write 0 to MD2.

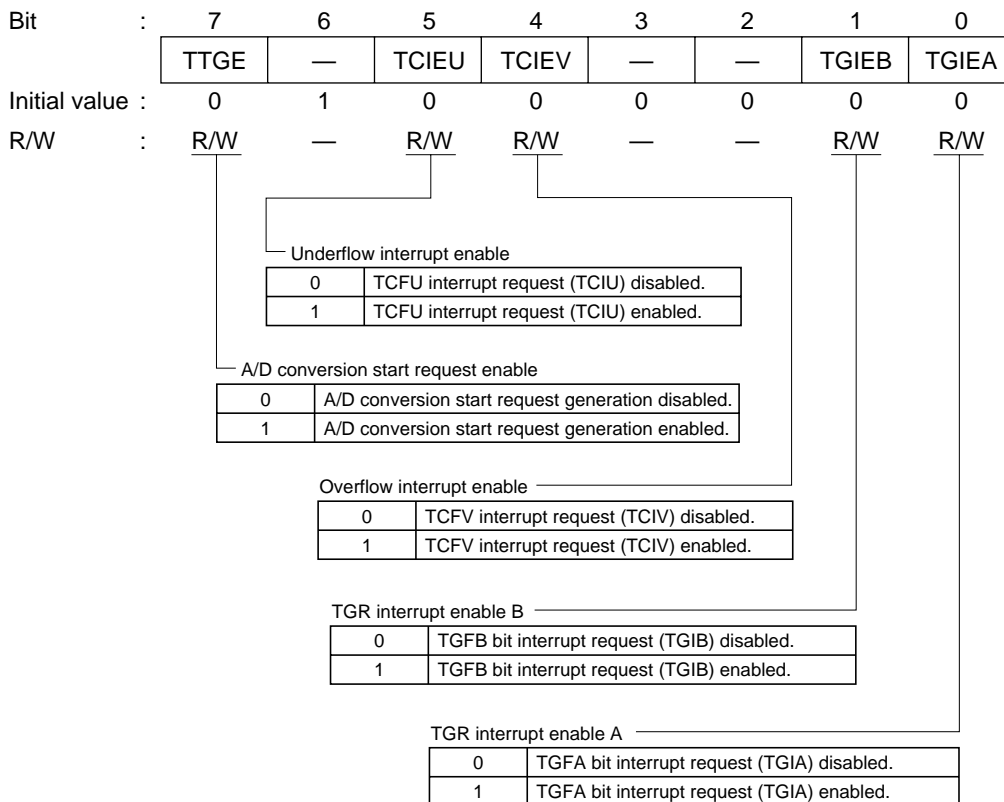
<b>TIER1—Timer Interrupt Enable Register 1</b>	<b>H'FF24</b>	<b>TPU1</b>
<b>TIER2—Timer Interrupt Enable Register 2</b>	<b>H'FF34</b>	<b>TPU2</b>
<b>TIER4—Timer Interrupt Enable Register 4</b>	<b>H'FE94</b>	<b>TPU4</b>
<b>TIER5—Timer Interrupt Enable Register 5</b>	<b>H'FEA4</b>	<b>TPU5</b>

Channel 1: TIER1

Channel 2: TIER2

Channel 4: TIER4

Channel 5: TIER5

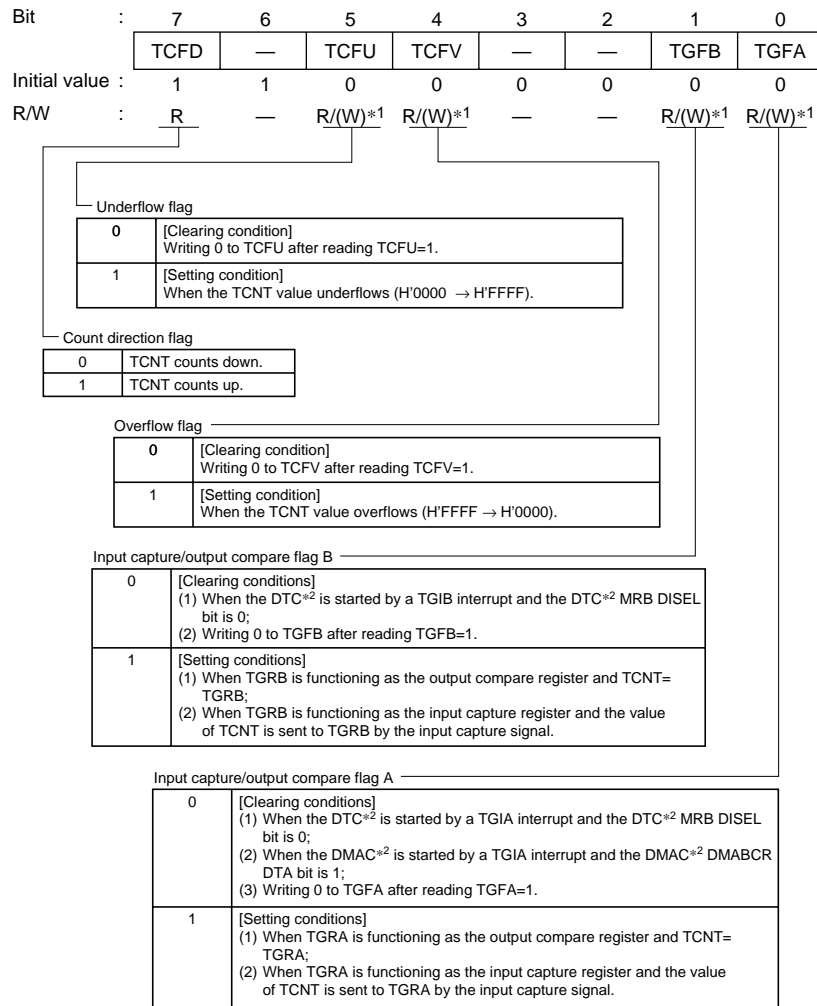


**TSR1—Timer Status Register 1**  
**TSR2—Timer Status Register 2**  
**TSR4—Timer Status Register 4**  
**TSR5—Timer Status Register 5**

**H'FF25**  
**H'FF35**  
**H'FE95**  
**H'FEA5**

**TPU1**  
**TPU2**  
**TPU4**  
**TPU5**

Channel 1: TSR1  
 Channel 2: TSR2  
 Channel 4: TSR4  
 Channel 5: TSR5



Notes: \*1 Only 0 can be written to these bits (to clear these flags).

\*2 This function is not available in the H8S/2695.



**TSTR—Timer Start Register****H'FEB0****TPU Common**

Bit	:	7	6	5	4	3	2	1	0
		—	—	CST5	CST4	CST3	CST2	CST1	CST0
Initial value	:	0	0	0	0	0	0	0	0
R/W	:	—	—	R/W	R/W	R/W	R/W	R/W	R/W

Counter start 5 to 0

0	TCNTn counting operation disabled.
1	TCNTn counting operation enabled.

(n= 5 to 0)

Note: When the TIOC pin is operating as an output pin, writing 0 to a CST bit disables counting. The TIOC pins output compare output level is maintained. When a CST bit is 0, the output level of the pin is updated to the set initial output value by writing to TIOR.

**TSYR—Timer Synchro Register****H'FEB1****TPU Common**

Bit	:	7	6	5	4	3	2	1	0
		—	—	SYNC5	SYNC4	SYNC3	SYNC2	SYNC1	SYNC0
Initial value	:	0	0	0	0	0	0	0	0
R/W	:	—	—	R/W	R/W	R/W	R/W	R/W	R/W

Timer sync 5 to 0

0	TCNTn operate independently (TCNTs are preset and cleared independently of other channels)
1	TCNTn operate in sync mode. Synchronized TCNT presetting and clearing enabled.

(n= 5 to 0)

Notes: 1. The SYNC bit of a minimum of two channels must be set to 1 in order to select sync operation.  
2. To enable sync clearing, in addition to the SYNC bits, the TCR CCLR2 to CCLR0 bits must be set for the TCNT clearing factors.

<b>IPRA—Interrupt Priority Register A</b>	<b>H'FEC0</b>	<b>Interrupt Controller</b>
<b>IPRB—Interrupt Priority Register B</b>	<b>H'FEC1</b>	
<b>IPRC—Interrupt Priority Register C</b>	<b>H'FEC2</b>	
<b>IPRD—Interrupt Priority Register D</b>	<b>H'FEC3</b>	
<b>IPRE—Interrupt Priority Register E</b>	<b>H'FEC4</b>	
<b>IPRF—Interrupt Priority Register F</b>	<b>H'FEC5</b>	
<b>IPRG—Interrupt Priority Register G</b>	<b>H'FEC6</b>	
<b>IPRH—Interrupt Priority Register H</b>	<b>H'FEC7</b>	
<b>IPRI—Interrupt Priority Register I</b>	<b>H'FEC8</b>	
<b>IPRJ—Interrupt Priority Register J</b>	<b>H'FEC9</b>	
<b>IPRK—Interrupt Priority Register K</b>	<b>H'FECA</b>	
<b>IPRL—Interrupt Priority Register L</b>	<b>H'FECEB</b>	
<b>IPRO—Interrupt Priority Register O</b>	<b>H'FECE</b>	

Bit	:	7	6	5	4	3	2	1	0
		—	IPR6	IPR5	IPR4	—	IPR2	IPR1	IPR0
Initial value	:	0	1	1	1	0	1	1	1
R/W	:	—	R/W	R/W	R/W	—	R/W	R/W	R/W



Interrupt factors vs IPR

Register	Bit	
	6 to 4	2 to 0
IPRA	IRQ0	IRQ1
IPRB	IRQ2	IRQ4
	IRQ3	IRQ5
IPRC	IRQ6 IRQ7	DTC*
IPRD	Watchdog timer 0	Refresh timer
IPRE	PC brake*	ADC Watchdog timer 1*
IPRF	TPU channel 0	TPU channel 1
IPRG	TPU channel 2	TPU channel 3
IPRH	TPU channel 4	ITPU channel 5
IPRI	8-bit timer channel 0*	8-bit timer channel 1*
IPRJ	DMAC*	SCI channel 0
IPRK	SCI channel 1	SCI channel 2
IPRL	8-bit timer 2, 3*	IIC (optional)*
IPRO	SCI channel 3	SCI channel 4

Note: \* This function is not available in the H8S/2695.

**ABWCR—Bus Width Control Register****H'FED0****Bus Controller**

Bit	:	7	6	5	4	3	2	1	0
		ABW7	ABW6	ABW5	ABW4	ABW3	ABW2	ABW1	ABW0

Modes 5 to 7:

Initial value	:	1	1	1	1	1	1	1	1
R/W	:	R/W	R/W	R/W	R/W	R/W	R/W	R/W	R/W

Mode 4

Initial value	:	0	0	0	0	0	0	0	0
R/W	:	R/W	R/W	R/W	R/W	R/W	R/W	R/W	R/W

Area 7 to 0 bus width control

0	Sets area n to 16-bit access.
1	Sets area n to 8-bit access.

(n= 7 to 0)

**ASTCR—Access State Control Register****H'FED1****Bus Controller**

Bit	:	7	6	5	4	3	2	1	0
		AST7	AST6	AST5	AST4	AST3	AST2	AST1	AST0
Initial value	:	1	1	1	1	1	1	1	1
R/W	:	R/W	R/W	R/W	R/W	R/W	R/W	R/W	R/W

Area 7 to 0 access state control

0	Area n set as 2-state access area. Insertion of wait states in area n external area access is disabled.
1	External area access of area n set as 3-state access area. Insertion of wait states in area n external area access is enabled.

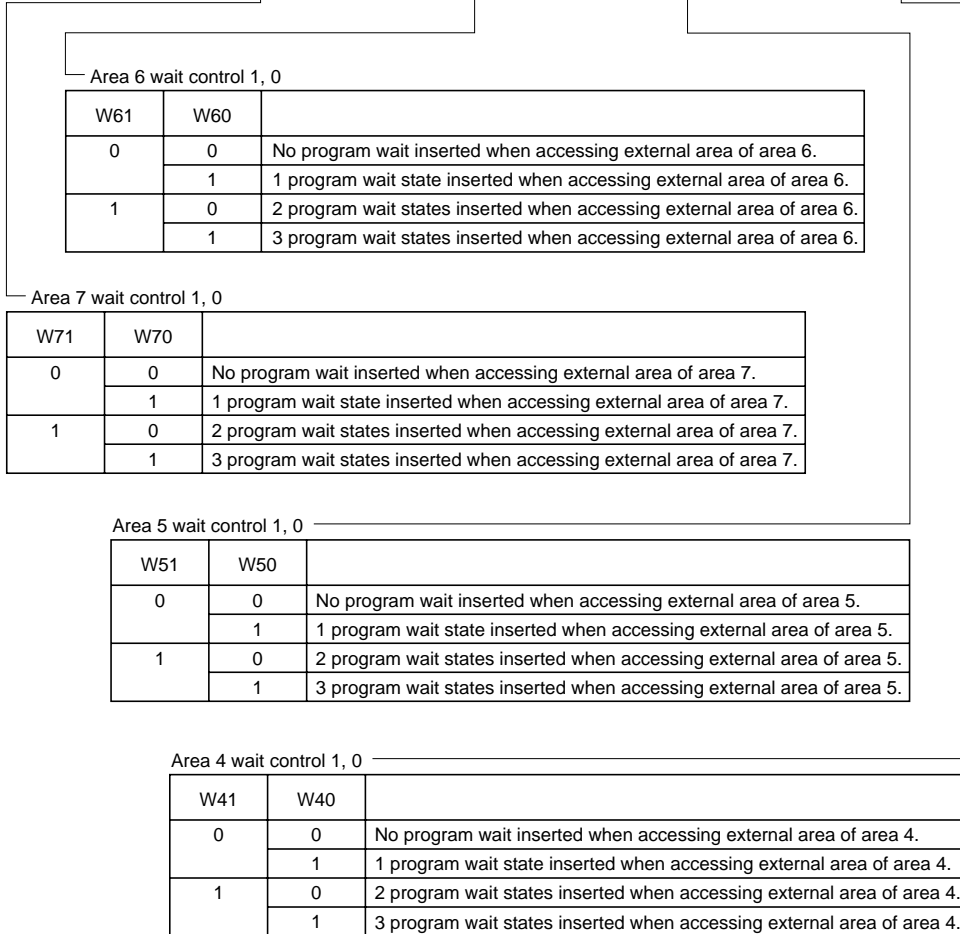
(n= 7 to 0)

**WCRH—Wait Control Register H**

**H'FED2**

**Bus Controller**

Bit	:	7	6	5	4	3	2	1	0
		W71	W70	W61	W60	W51	W50	W41	W40
Initial value	:	1	1	1	1	1	1	1	1
R/W	:	R/W	R/W	R/W	R/W	R/W	R/W	R/W	R/W



Area 6 wait control 1, 0		
W61	W60	
0	0	No program wait inserted when accessing external area of area 6.
	1	1 program wait state inserted when accessing external area of area 6.
1	0	2 program wait states inserted when accessing external area of area 6.
	1	3 program wait states inserted when accessing external area of area 6.

Area 7 wait control 1, 0		
W71	W70	
0	0	No program wait inserted when accessing external area of area 7.
	1	1 program wait state inserted when accessing external area of area 7.
1	0	2 program wait states inserted when accessing external area of area 7.
	1	3 program wait states inserted when accessing external area of area 7.

Area 5 wait control 1, 0		
W51	W50	
0	0	No program wait inserted when accessing external area of area 5.
	1	1 program wait state inserted when accessing external area of area 5.
1	0	2 program wait states inserted when accessing external area of area 5.
	1	3 program wait states inserted when accessing external area of area 5.

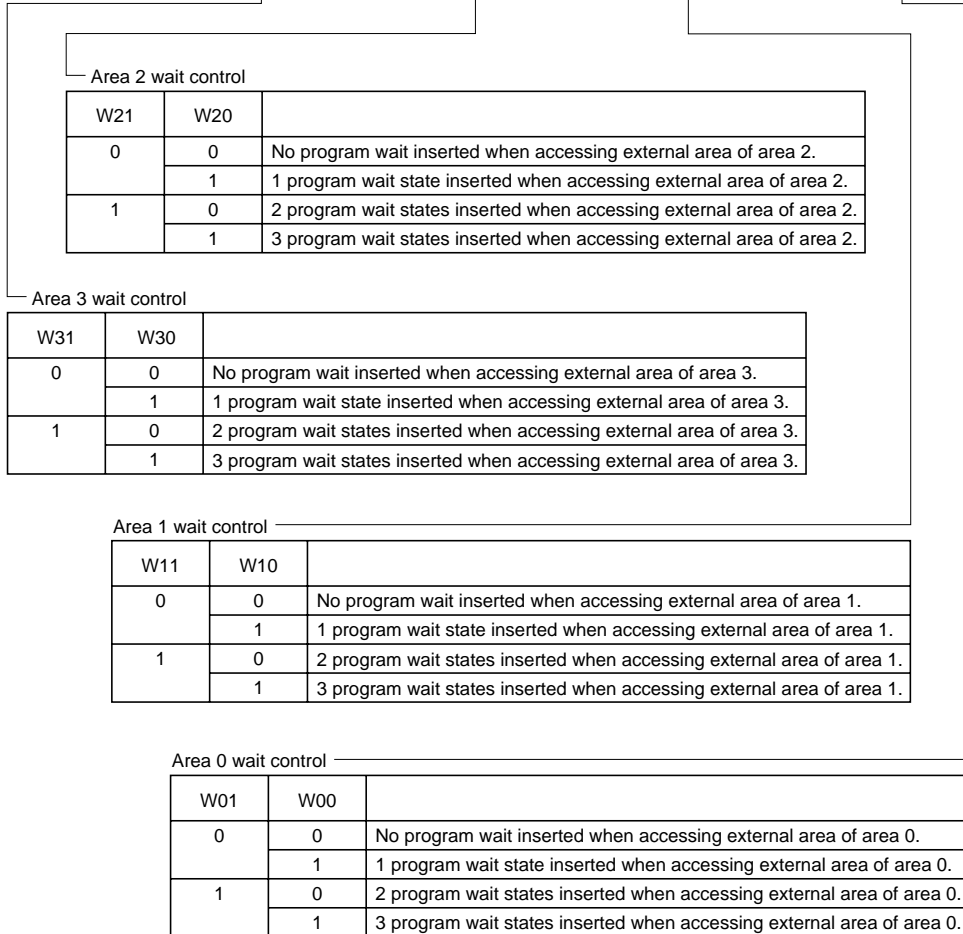
Area 4 wait control 1, 0		
W41	W40	
0	0	No program wait inserted when accessing external area of area 4.
	1	1 program wait state inserted when accessing external area of area 4.
1	0	2 program wait states inserted when accessing external area of area 4.
	1	3 program wait states inserted when accessing external area of area 4.

**WCRL—Wait Control Register**

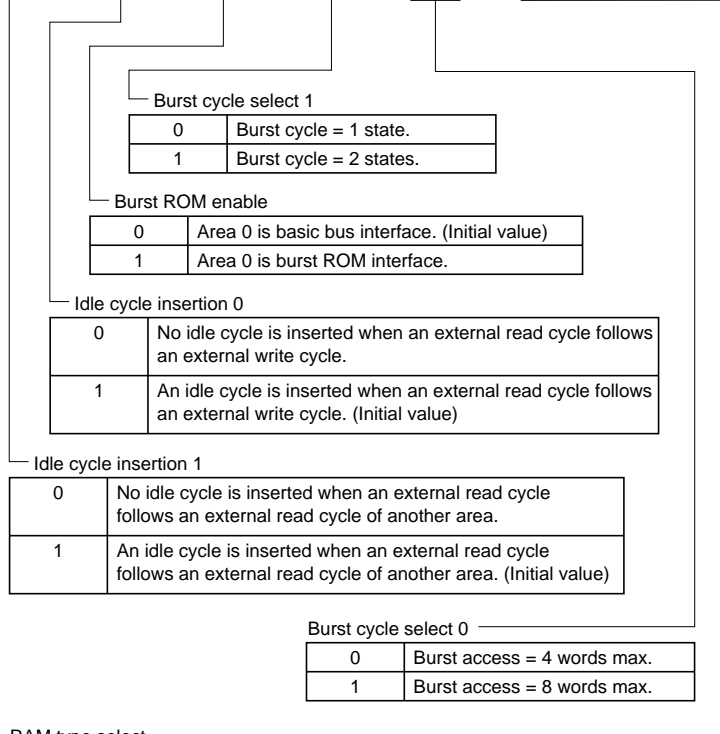
**H'FED3**

**Bus Controller**

Bit	:	7	6	5	4	3	2	1	0
		W31	W30	W21	W20	W11	W10	W01	W00
Initial value	:	1	1	1	1	1	1	1	1
R/W	:	R/W	R/W	R/W	R/W	R/W	R/W	R/W	R/W



Bit	:	7	6	5	4	3	2	1	0
		ICIS1	ICIS0	BRSTRM	BRSTS1	BRSTS0	RMTS2*1	RMTS1*1	RMTS0*1
Initial value	:	1	1	0	1	0	0	0	0
R/W	:	R/W	R/W	R/W	R/W	R/W	R/W	R/W	R/W



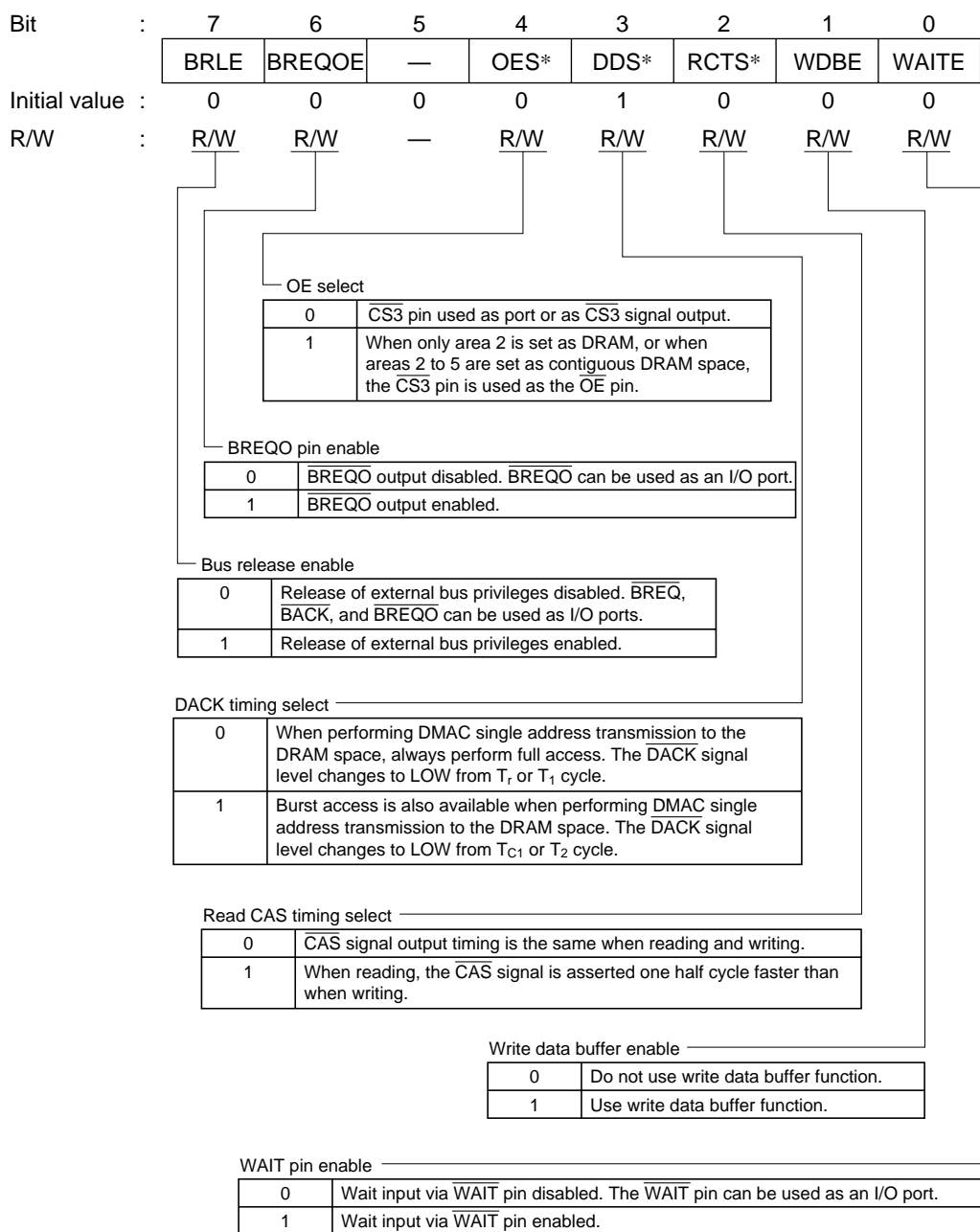
RAM type select

RMTS2	RMTS1	RMTS0	Area 5	Area 4	Area 3	Area 2
0	0	0	Normal area			
		1	Normal area			DRAM area*
	1	0	Normal area		DRAM area*	
		1	DRAM area*			
1	1	1	Contiguous DRAM area*			

Notes: When all areas selected in the DRAM area are set for 8-bit access, the PF2 pin can be used as an I/O port or BREQO or WAIT. When set for contiguous DRAM the bus widths for areas 2 to 5 and the number of access states (number of programmable waits) must be set to the same values. Do not attempt to set combinations other than those shown in the table.

\* This function is not available in the H8S/2695.

Note: \*1 In the H8S/2695 only a 0 may be written to RMTS2, RMTS1, or RMTS0.



Note: \* This function is not available in the H8S/2695.

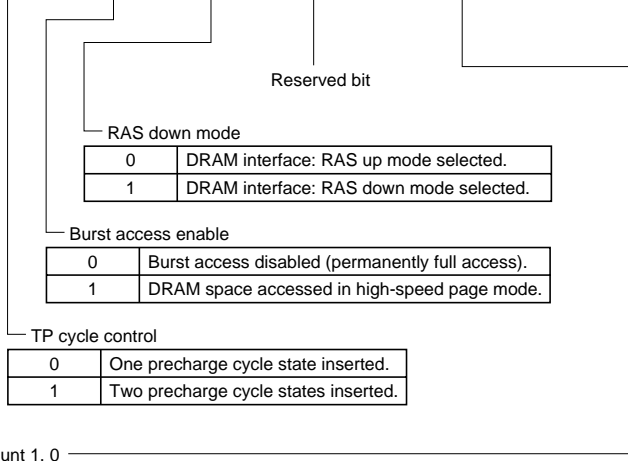
**MCR—Memory Control Register**

**H'FED6**

**Bus Controller**

(This function is not available in the H8S/2695.)

Bit	:	7	6	5	4	3	2	1	0
		TPC	BE	RCDM	CW2	MXC1	MXC0	RLW1	RLW0
Initial value	:	0	0	0	0	0	0	0	0
R/W	:	R/W	R/W	R/W	R/W	R/W	R/W	R/W	R/W



RAS down mode

0	DRAM interface: RAS up mode selected.
1	DRAM interface: RAS down mode selected.

Burst access enable

0	Burst access disabled (permanently full access).
1	DRAM space accessed in high-speed page mode.

TP cycle control

0	One precharge cycle state inserted.
1	Two precharge cycle states inserted.

Multiplex shift count 1, 0

MXC1	MXC0	
0	0	8-bit shift (1) When set for 8-bit access space: Row addresses A23 to A8 are targets of comparison. (2) When set for 16-bit access space: Row addresses A23 to A9 are targets of comparison.
	1	9-bit shift (1) When set for 8-bit access space: Row addresses A23 to A9 are targets of comparison. (2) When set for 16-bit access space: Row addresses A23 to A10 are targets of comparison.
1	0	10-bit shift (1) When set for 8-bit access space: Row addresses A23 to A10 are targets of comparison. (2) When set for 16-bit access space: Row addresses A23 to A11 are targets of comparison.
	1	—

Refresh cycle wait control 1, 0

RLW1	RLW0	
0	0	Do not insert wait state.
	1	Insert 1 wait state.
1	0	Insert 2 wait states.
	1	Insert 3 wait states.



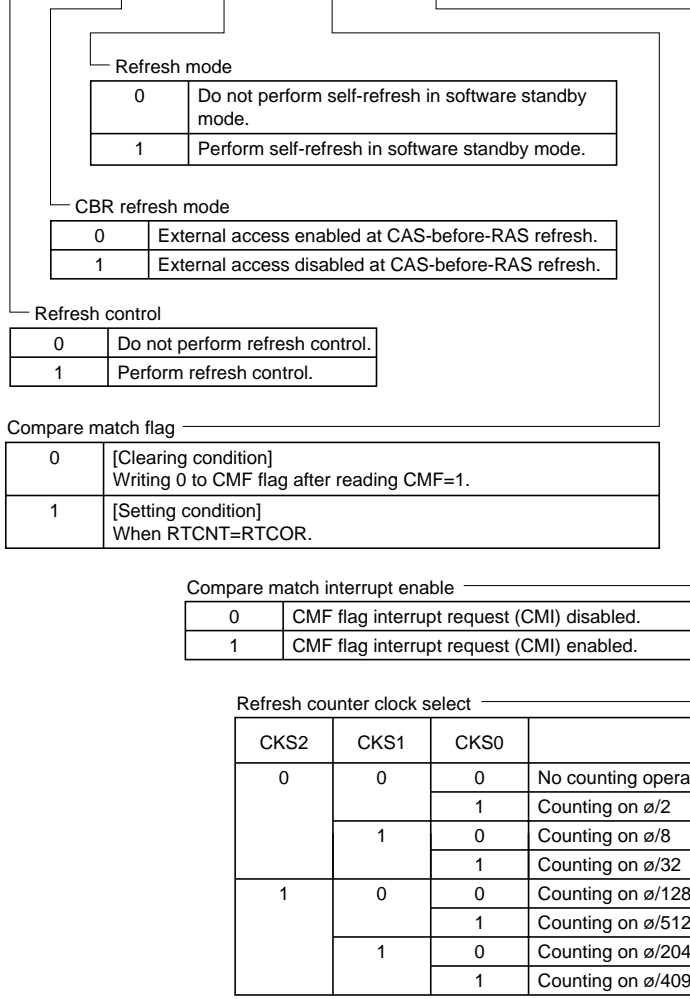
**DRAMCR—DRAM Control Register**

**H'FED7**

**Bus Controller**

(This function is not available in the H8S/2695.)

Bit	:	7	6	5	4	3	2	1	0
		RFSHE	CBRM	RMODE	CMF	CMIE	CKS2	CKS1	CKS0
Initial value	:	0	0	0	0	0	0	0	0
R/W	:	R/W	R/W	R/W	R/W	R/W	R/W	R/W	R/W



**RTCNT—Refresh Timer Counter** **H'FED8** **Bus Controller**  
 (This function is not available in the H8S/2695.)

Bit	:	7	6	5	4	3	2	1	0										
		<table style="width: 100%; border-collapse: collapse;"> <tr> <td style="width: 12.5%; height: 20px;"></td> <td style="width: 12.5%;"></td> <td style="width: 12.5%;"></td> <td style="width: 12.5%;"></td> <td style="width: 12.5%;"></td> <td style="width: 12.5%;"></td> <td style="width: 12.5%;"></td> <td style="width: 12.5%;"></td> <td style="width: 12.5%;"></td> <td style="width: 12.5%;"></td> </tr> </table>																	
Initial value	:	0	0	0	0	0	0	0	0										
R/W	:	R/W	R/W	R/W	R/W	R/W	R/W	R/W	R/W										

**RTCOR—Refresh Time Constant Register** **H'FED9** **Bus Controller**  
 (This function is not available in the H8S/2695.)

Bit	:	7	6	5	4	3	2	1	0										
		<table style="width: 100%; border-collapse: collapse;"> <tr> <td style="width: 12.5%; height: 20px;"></td> <td style="width: 12.5%;"></td> <td style="width: 12.5%;"></td> <td style="width: 12.5%;"></td> <td style="width: 12.5%;"></td> <td style="width: 12.5%;"></td> <td style="width: 12.5%;"></td> <td style="width: 12.5%;"></td> <td style="width: 12.5%;"></td> <td style="width: 12.5%;"></td> </tr> </table>																	
Initial value	:	1	1	1	1	1	1	1	1										
R/W	:	R/W	R/W	R/W	R/W	R/W	R/W	R/W	R/W										

**RAMER—RAM Emulation Register** **H'FEDB** **FLASH**

Bit	:	7	6	5	4	3	2	1	0								
		<table style="width: 100%; border-collapse: collapse;"> <tr> <td style="width: 12.5%; height: 20px; text-align: center;">—</td> <td style="width: 12.5%; text-align: center;">—</td> <td style="width: 12.5%; text-align: center;">—</td> <td style="width: 12.5%; text-align: center;">—</td> <td style="width: 12.5%; text-align: center;">RAMS</td> <td style="width: 12.5%; text-align: center;">RAM2</td> <td style="width: 12.5%; text-align: center;">RAM1</td> <td style="width: 12.5%; text-align: center;">RAM0</td> </tr> </table>								—	—	—	—	RAMS	RAM2	RAM1	RAM0
—	—	—	—	RAMS	RAM2	RAM1	RAM0										
Initial value	:	0	0	0	0	0	0	0	0								
R/W	:	R	R	R/W	R/W	R/W	R/W	R/W	R/W								

Flash memory area selection

Addresses	Block Name	RAMS	RAM1	RAM1	RAM0
H'FFD000–H'FFDFFF	RAM area 4 kbytes	0	*	*	*
H'000000–H'000FFF	EB0 (4 kbytes)	1	0	0	0
H'001000–H'001FFF	EB1 (4 kbytes)	1	0	0	1
H'002000–H'002FFF	EB2 (4 kbytes)	1	0	1	0
H'003000–H'003FFF	EB3 (4 kbytes)	1	0	1	1
H'004000–H'004FFF	EB4 (4 kbytes)	1	1	0	0
H'005000–H'005FFF	EB5 (4 kbytes)	1	1	0	1
H'006000–H'006FFF	EB6 (4 kbytes)	1	1	1	0
H'007000–H'007FFF	EB7 (4 kbytes)	1	1	1	1

\* : Don't care

RAM Select

0	Emulation not selected Program/erase-protection of all flash memory blocks is disabled
1	Emulation selected Program/erase-protection of all flash memory blocks is enabled

**MAR0AH—Memory Address Register 0AH**

**H'FEE0**

**DMAC**

**MAR0AL—Memory Address Register 0AL**

**H'FEE2**

**DMAC**

Bit	:	31	30	29	28	27	26	25	24	23	22	21	20	19	18	17	16
MAR	:	—	—	—	—	—	—	—	—								
Initial value	:	0	0	0	0	0	0	0	0	*	*	*	*	*	*	*	*
R/W	:	—	—	—	—	—	—	—	—	R/W	R/W	R/W	R/W	R/W	R/W	R/W	R/W
Bit	:	15	14	13	12	11	10	9	8	7	6	5	4	3	2	1	0
MAR	:																
Initial value	:	*	*	*	*	*	*	*	*	*	*	*	*	*	*	*	*
R/W	:	R/W	R/W	R/W	R/W	R/W	R/W	R/W	R/W	R/W	R/W	R/W	R/W	R/W	R/W	R/W	R/W

In short address mode: Specifies transfer destination/transfer source address

In full address mode: Specifies transfer destination

\* : Undefined

**IOAR0A—I/O Address Register 0A**

**H'FEE4**

**DMAC**

**IOAR1A—I/O Address Register 1A**

**H'FEF4**

**DMAC**

Bit	:	15	14	13	12	11	10	9	8	7	6	5	4	3	2	1	0
IOAR	:																
Initial value	:	*	*	*	*	*	*	*	*	*	*	*	*	*	*	*	*
R/W	:	R/W	R/W	R/W	R/W	R/W	R/W	R/W	R/W	R/W	R/W	R/W	R/W	R/W	R/W	R/W	R/W

In short address mode: Specifies transfer destination/transfer source address

In full address mode: Not used

\* : Undefined

**ETCR0A—Transfer Count Register 0A****H'FEE6****DMAC**

Bit	:	15	14	13	12	11	10	9	8	7	6	5	4	3	2	1	0
ETCR0A	:																
Initial value	:	*	*	*	*	*	*	*	*	*	*	*	*	*	*	*	*
R/W	:	R/W	R/W	R/W	R/W	R/W	R/W	R/W	R/W	R/W	R/W	R/W	R/W	R/W	R/W	R/W	R/W

Sequential mode and idle mode Normal mode Transfer counter

Repeat mode Holds number of transfers Transfer counter

Block transfer mode Holds block size Block size counter

\*: Undefined

**MAR0BH—Memory Address Register 0BH****H'FEE8****DMAC****MAR0BL—Memory Address Register 0BL****H'FEEA****DMAC**

Bit	:	31	30	29	28	27	26	25	24	23	22	21	20	19	18	17	16
MAR0BH	:	—	—	—	—	—	—	—									
Initial value	:	0	0	0	0	0	0	0	0	*	*	*	*	*	*	*	*
R/W	:	—	—	—	—	—	—	—	—	R/W	R/W	R/W	R/W	R/W	R/W	R/W	R/W

Bit	:	15	14	13	12	11	10	9	8	7	6	5	4	3	2	1	0
MAR0BL	:																
Initial value	:	*	*	*	*	*	*	*	*	*	*	*	*	*	*	*	*
R/W	:	R/W	R/W	R/W	R/W	R/W	R/W	R/W	R/W	R/W	R/W	R/W	R/W	R/W	R/W	R/W	R/W

In short address mode: Specifies transfer destination/transfer source address

In full address mode: Specifies transfer destination

\*: Undefined

**IOAR0B—I/O Address Register 0B**  
**IOAR1B—I/O Address Register 1B**

**H'FEEC**  
**H'FEFC**

**DMAC**  
**DMAC**

Bit	:	15	14	13	12	11	10	9	8	7	6	5	4	3	2	1	0
IOAR0B	:																
Initial value	:	*	*	*	*	*	*	*	*	*	*	*	*	*	*	*	*
R/W	:	R/W	R/W	R/W	R/W	R/W	R/W	R/W	R/W	R/W	R/W	R/W	R/W	R/W	R/W	R/W	R/W

In short address mode: Specifies transfer destination/transfer source address  
 In full address mode: Not used

\*: Undefined

**ETCR0B—Transfer Count Register 0B**

**H'FEEE**

**DMAC**

Bit	:	15	14	13	12	11	10	9	8	7	6	5	4	3	2	1	0
ETCR0B	:																
Initial value	:	*	*	*	*	*	*	*	*	*	*	*	*	*	*	*	*
R/W	:	R/W	R/W	R/W	R/W	R/W	R/W	R/W	R/W	R/W	R/W	R/W	R/W	R/W	R/W	R/W	R/W

Sequential mode and idle mode \_\_\_\_\_ Transfer counter

Repeat mode \_\_\_\_\_ Holds number of transfers \_\_\_\_\_ Transfer counter

Block transfer mode \_\_\_\_\_ Block transfer counter

Note: Not used in normal mode.

\*: Undefined

**MAR1AH—Memory Address Register 1AH****H'FEF0****DMAC****MAR1AL—Memory Address Register 1AL****H'FEF2****DMAC**

Bit	:	31	30	29	28	27	26	25	24	23	22	21	20	19	18	17	16
MAR1AH	:	—	—	—	—	—	—	—	—								
Initial value	:	0	0	0	0	0	0	0	0	*	*	*	*	*	*	*	*
R/W	:	—	—	—	—	—	—	—	—	R/W	R/W	R/W	R/W	R/W	R/W	R/W	R/W

Bit	:	15	14	13	12	11	10	9	8	7	6	5	4	3	2	1	0
MAR1AL	:																
Initial value	:	*	*	*	*	*	*	*	*	*	*	*	*	*	*	*	*
R/W	:	R/W	R/W	R/W	R/W	R/W	R/W	R/W	R/W	R/W	R/W	R/W	R/W	R/W	R/W	R/W	R/W

In short address mode: Specifies transfer destination/transfer source address  
 In full address mode: Specifies transfer destination

\*: Undefined

**ETCR1A—Transfer Count Register 1A****H'FEF6****DMAC**

Bit	:	15	14	13	12	11	10	9	8	7	6	5	4	3	2	1	0
ETCR1A	:																
Initial value	:	*	*	*	*	*	*	*	*	*	*	*	*	*	*	*	*
R/W	:	R/W	R/W	R/W	R/W	R/W	R/W	R/W	R/W	R/W	R/W	R/W	R/W	R/W	R/W	R/W	R/W

Sequential mode	Transfer counter	
Idle mode	Transfer counter	
Normal mode	Transfer counter	
Repeat mode	Holds number of transfers	Transfer counter
Block transfer mode	Holds block size	Block size counter

\*: Undefined

**MAR1BH—Memory Address Register 1BH**  
**MAR1BL—Memory Address Register 1BL**

**H'FEF8**  
**H'FEFA**

**DMAC**  
**DMAC**

Bit	:	31	30	29	28	27	26	25	24	23	22	21	20	19	18	17	16
MAR1BH	:	—	—	—	—	—	—	—	—								
Initial value	:	0	0	0	0	0	0	0	0	*	*	*	*	*	*	*	*
R/W	:	—	—	—	—	—	—	—	—	R/W	R/W	R/W	R/W	R/W	R/W	R/W	R/W

Bit	:	15	14	13	12	11	10	9	8	7	6	5	4	3	2	1	0
MAR1BL	:																
Initial value	:	*	*	*	*	*	*	*	*	*	*	*	*	*	*	*	*
R/W	:	R/W	R/W	R/W	R/W	R/W	R/W	R/W	R/W	R/W	R/W	R/W	R/W	R/W	R/W	R/W	R/W

In short address mode: Specifies transfer destination/transfer source address  
 In full address mode: Not used

\*: Undefined

**ETCR1B—Transfer Count Register 1B**

**H'FEFE**

**DMAC**

Bit	:	15	14	13	12	11	10	9	8	7	6	5	4	3	2	1	0
ETCR1B	:																
Initial value	:	*	*	*	*	*	*	*	*	*	*	*	*	*	*	*	*
R/W	:	R/W	R/W	R/W	R/W	R/W	R/W	R/W	R/W	R/W	R/W	R/W	R/W	R/W	R/W	R/W	R/W

Sequential mode and idle mode: \_\_\_\_\_ Transfer counter

Repeat mode: \_\_\_\_\_ Holds number of transfers \_\_\_\_\_ Transfer counter

Block transfer mode: \_\_\_\_\_ Block transfer counter

Note: Not used in normal mode.

\*: Undefined

**P1DR—Port 1 Data Register** **H'FF00** **Port**

Bit	:	7	6	5	4	3	2	1	0
		P17DR	P16DR	P15DR	P14DR	P13DR	P12DR	P11DR	P10DR
Initial value	:	0	0	0	0	0	0	0	0
R/W	:	R/W	R/W	R/W	R/W	R/W	R/W	R/W	R/W

**P3DR—Port 3 Data Register** **H'FF02** **Port**

Bit	:	7	6	5	4	3	2	1	0
		P37DR	P36DR	P35DR	P34DR	P33DR	P32DR	P31DR	P30DR
Initial value	:	0	0	0	0	0	0	0	0
R/W	:	R/W	R/W	R/W	R/W	R/W	R/W	R/W	R/W

**P7DR—Port 7 Data Register** **H'FF06** **Port**

Bit	:	7	6	5	4	3	2	1	0
		P77DR	P76DR	P75DR	P74DR	P73DR	P72DR	P71DR	P70DR
Initial value	:	0	0	0	0	0	0	0	0
R/W	:	R/W	R/W	R/W	R/W	R/W	R/W	R/W	R/W

**PADR—Port A Data Register** **H'FF09** **Port**

Bit	:	7	6	5	4	3	2	1	0
		—	—	—	—	PA3DR	PA2DR	PA1DR	PA0DR
Initial value	:	Undefined				0	0	0	0
R/W	:	—	—	—	—	R/W	R/W	R/W	R/W

**PBDR—Port B Data Register** **H'FF0A** **Port**

Bit	:	7	6	5	4	3	2	1	0
		PB7DR	PB6DR	PB5DR	PB4DR	PB3DR	PB2DR	PB1DR	PB0DR
Initial value	:	0	0	0	0	0	0	0	0
R/W	:	R/W	R/W	R/W	R/W	R/W	R/W	R/W	R/W



**PCDR—Port C Data Register** **H'FF0B** **Port**

Bit	:	7	6	5	4	3	2	1	0
		PC7DR	PC6DR	PC5DR	PC4DR	PC3DR	PC2DR	PC1DR	PC0DR
Initial value	:	0	0	0	0	0	0	0	0
R/W	:	R/W	R/W	R/W	R/W	R/W	R/W	R/W	R/W

**PDDR—Port D Data Register** **H'FF0C** **Port**

Bit	:	7	6	5	4	3	2	1	0
		PD7DR	PD6DR	PD5DR	PD4DR	PD3DR	PD2DR	PD1DR	PD0DR
Initial value	:	0	0	0	0	0	0	0	0
R/W	:	R/W	R/W	R/W	R/W	R/W	R/W	R/W	R/W

**PEDR—Port E Data Register** **H'FF0D** **Port**

Bit	:	7	6	5	4	3	2	1	0
		PE7DR	PE6DR	PE5DR	PE4DR	PE3DR	PE2DR	PE1DR	PE0DR
Initial value	:	0	0	0	0	0	0	0	0
R/W	:	R/W	R/W	R/W	R/W	R/W	R/W	R/W	R/W

**PFDR—Port F Data Register** **H'FF0E** **Port**

Bit	:	7	6	5	4	3	2	1	0
		PF7DR	PF6DR	PF5DR	PF4DR	PF3DR	PF2DR	PF1DR	PF0DR
Initial value	:	0	0	0	0	0	0	0	0
R/W	:	R/W	R/W	R/W	R/W	R/W	R/W	R/W	R/W

**PGDR—Port G Data Register** **H'FF0F** **Port**

Bit	:	7	6	5	4	3	2	1	0
		—	—	—	PG4DR	PG3DR	PG2DR	PG1DR	PG0DR
Initial value	:	Undefined	Undefined	Undefined	0	0	0	0	0
R/W	:	—	—	—	R/W	R/W	R/W	R/W	R/W

**DMAWER—DMA Write Enable Register**

**H'FF60**

**DMAC**

(This function is not available in the H8S/2695.)

Bit	:	7	6	5	4	3	2	1	0
DMAWER	:	—	—	—	—	WE1B	WE1A	WE0B	WE0A
Initial value	:	0	0	0	0	0	0	0	0
R/W	:	—	—	—	—	R/W	R/W	R/W	R/W

Write enable 1B

0	Disables writing to all DMACR1B bits, DMABCR bits 11, 7, and 3, and DMATCR bit 5. (initial value)
1	Enables writing to all DMACR1B bits, DMABCR bits 11, 7, and 3, and DMATCR bit 5.

Write enable 1A

0	Disables writing to all DMACR1A bits, and DMABCR bits 10, 6, and 2. (initial value)
1	Enables writing to all DMACR1A bits, and DMABCR bits 10, 6, and 2.

Write enable 0B

0	Disables writing to all DMACR0B bits, DMABCR bits 9, 5, and 1, and DMATCR bit 4 (initial value)
1	Enables writing to all DMACR0B bits, DMABCR bits 9, 5, and 1, and DMATCR bit 4.

Write enable 0A

0	Disables writing to all DMACR0A bits, and DMABCR bits 8, 4, and 0. (initial value)
1	Enables writing to all DMACR0A bits, and DMABCR bits 8, 4, and 0.

**DMATCR—DMA Terminal Control Register**

**H'FF61**

**DMAC**

(This function is not available in the H8S/2695.)

Bit	:	7	6	5	4	3	2	1	0
DMATCR	:	—	—	TEE1	TEE0	—	—	—	—
Initial value	:	0	0	0	0	0	0	0	0
R/W	:	—	—	R/W	R/W	—	—	—	—

Transfer end pin enable 0

0	Disables TEND0 pin output.
1	Enables TEND0 pin output.

Transfer end pin enable 1

0	Disables TEND1 pin output.
1	Enables TEND1 pin output.

<b>DMACR0A—DMA Control Register 0A</b>	<b>H'FF62</b>	<b>DMAC</b>
<b>DMACR0B—DMA Control Register 0B</b>	<b>H'FF63</b>	<b>DMAC</b>
<b>DMACR1A—DMA Control Register 1A</b>	<b>H'FF64</b>	<b>DMAC</b>
<b>DMACR1B—DMA Control Register 1B</b>	<b>H'FF65</b>	<b>DMAC</b>

(These functions are not available in the H8S/2695.)

**Full address mode**

Bit	:	15	14	13	12	11	10	9	8
DMACRA	:	DTSZ	SAID	SAIDE	BLKDIR	BLKE	—	—	—
Initial value	:	0	0	0	0	0	0	0	0
R/W	:	R/W	R/W	R/W	R/W	R/W	R/W	R/W	R/W

Block Direction/Block Enable

0	0	Transfer in normal mode
	1	Transfer in block transfer mode, destination is block area
1	0	Transfer in normal mode
	1	Transfer in block transfer mode, source is block area

Source Address Increment/Decrement

0	0	MARA is fixed
	1	MARA is incremented after a data transfer <ul style="list-style-type: none"> <li>• When DTSZ = 0, MARA is incremented by 1 after a transfer</li> <li>• When DTSZ = 1, MARA is incremented by 2 after a transfer</li> </ul>
1	0	MARA is fixed
	1	MARA is decremented after a data transfer <ul style="list-style-type: none"> <li>• When DTSZ = 0, MARA is decremented by 1 after a transfer</li> <li>• When DTSZ = 1, MARA is decremented by 2 after a transfer</li> </ul>

Data Transfer Size

0	Byte-size transfer
1	Word-size transfer

### Full address mode

Bit	:	7	6	5	4	3	2	1	0
DMACRB	:	—	DAID	DAIDE	—	DTF3	DTF2	DTF1	DTF0
Initial value	:	0	0	0	0	0	0	0	0
R/W	:	R/W	R/W	R/W	R/W	R/W	R/W	R/W	R/W

Data Transfer Factor				Block Transfer Mode	Normal Mode	
DTF3	DTF2	DTF1	DTF0			
0	0	0	0	— (initial value)	—	
			1	Activated by A/D converter conversion end interrupt	—	
		1	0	Activated by $\overline{\text{DREQ}}$ pin falling edge input	Activated by $\overline{\text{DREQ}}$ pin falling edge input	
			1	Activated by $\overline{\text{DREQ}}$ pin low-level input*	Activated by $\overline{\text{DREQ}}$ pin low-level input	
	1	0	0	Activated by SCI channel 0 transmit-data-empty interrupt	—	
			1	Activated by SCI channel 0 reception complete interrupt	—	
		1	0	Activated by SCI channel 1 transmit-data-empty interrupt	Auto-request (cycle steal)	
			1	Activated by SCI channel 1 reception complete interrupt	Auto-request (burst)	
	1	0	0	0	Activated by TPU channel 0 compare match/input capture A interrupt	—
				1	Activated by TPU channel 1 compare match/input capture A interrupt	—
			1	0	Activated by TPU channel 2 compare match/input capture A interrupt	—
				1	Activated by TPU channel 3 compare match/input capture A interrupt	—
1		0	0	Activated by TPU channel 4 compare match/input capture A interrupt	—	
			1	Activated by TPU channel 5 compare match/input capture A interrupt	—	
		1	0	—	—	
			1	—	—	

Note: \* Detected as a low level in the first transfer after transfer is enabled.

#### Destination Address Increment/Decrement

0	0	MARB is fixed
	1	MARB is incremented after a data transfer <ul style="list-style-type: none"> <li>• When DTSZ = 0, MARB is incremented by 1 after a transfer</li> <li>• When DTSZ = 1, MARB is incremented by 2 after a transfer</li> </ul>
1	0	MARB is fixed
	1	MARB is decremented after a data transfer <ul style="list-style-type: none"> <li>• When DTSZ = 0, MARB is decremented by 1 after a transfer</li> <li>• When DTSZ = 1, MARB is decremented by 2 after a transfer</li> </ul>

### Short address mode

Bit	7	6	5	4	3	2	1	0
DMACR	DTSZ	DTID	RPE	DTDIR	DTF3	DTF2	DTF1	DTF0
Initial value	0	0	0	0	0	0	0	0
Read/Write	R/W	R/W	R/W	R/W	R/W	R/W	R/W	R/W

#### Data Transfer Size

0	Byte-size transfer
1	Word-size transfer

#### Data Transfer Increment/Decrement

0	MAR is incremented after a data transfer <ul style="list-style-type: none"> <li>When DTSZ = 0, MAR is incremented by 1 after a transfer</li> <li>When DTSZ = 1, MAR is incremented by 2 after a transfer</li> </ul>
1	MAR is decremented after a data transfer <ul style="list-style-type: none"> <li>When DTSZ = 0, MAR is decremented by 1 after a transfer</li> <li>When DTSZ = 1, MAR is decremented by 2 after a transfer</li> </ul>

#### Data Transfer Factor

				Channel A	Channel B
0	0	0	0	—	—
		1	0	Activated by A/D converter conversion end interrupt	—
1	0	0	—	—	Activated by $\overline{\text{DREQ}}$ pin falling edge input
		1	—	—	Activated by $\overline{\text{DREQ}}$ pin low-level input
1	0	0	0	Activated by SCI channel 0 transmit-data-empty interrupt	—
		1	0	Activated by SCI channel 0 reception complete interrupt	—
	1	0	0	Activated by SCI channel 1 transmit-data-empty interrupt	—
		1	0	Activated by SCI channel 1 reception complete interrupt	—
1	0	0	0	Activated by TPU channel 0 compare match/input capture A interrupt	—
		1	0	Activated by TPU channel 1 compare match/input capture A interrupt	—
	1	0	0	Activated by TPU channel 2 compare match/input capture A interrupt	—
		1	0	Activated by TPU channel 3 compare match/input capture A interrupt	—
	1	0	0	Activated by TPU channel 4 compare match/input capture A interrupt	—
		1	0	Activated by TPU channel 5 compare match/input capture A interrupt	—
1	0	—	—	—	
1	1	—	—	—	

#### Data Transfer Direction

DMABCR	Bit 4	Description	
0	SAE	DTDIR	
	0	0	Transfer with MAR as source address and IOAR as destination address (initial value)
1	0	1	Transfer with IOAR as source address and MAR as destination address
	1	0	Transfer with MAR as source address and $\overline{\text{DACK}}$ pin as write strobe
1	1	1	Transfer with $\overline{\text{DACK}}$ pin as read strobe and MAR as destination address

#### Repeat Enable

Bit 5	DMABCR	Description	
0	RPE	DTIE	
	0	0	Transfer in sequential mode (no transfer end interrupt) (initial value)
1	0	1	Transfer in sequential mode (with transfer end interrupt)
	1	0	Transfer in repeat mode (no transfer end interrupt)
1	1	1	Transfer in idle mode (with transfer end interrupt)

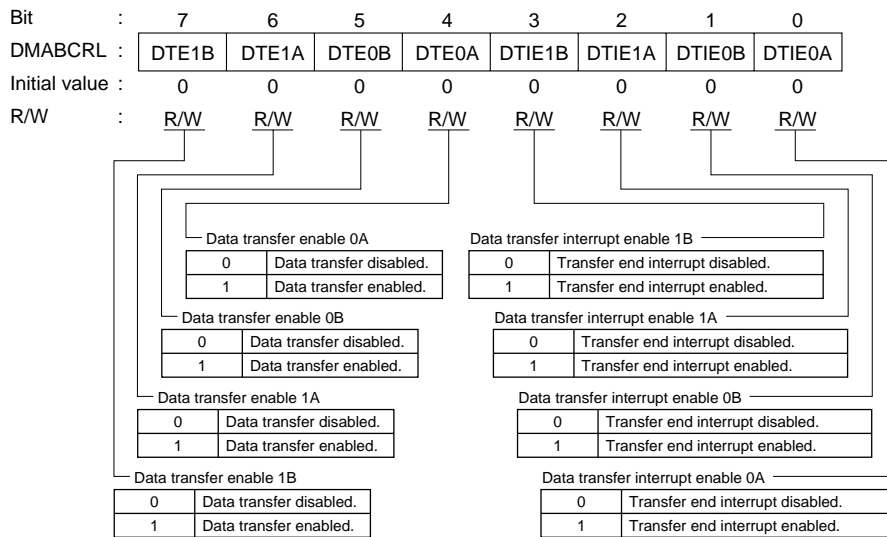
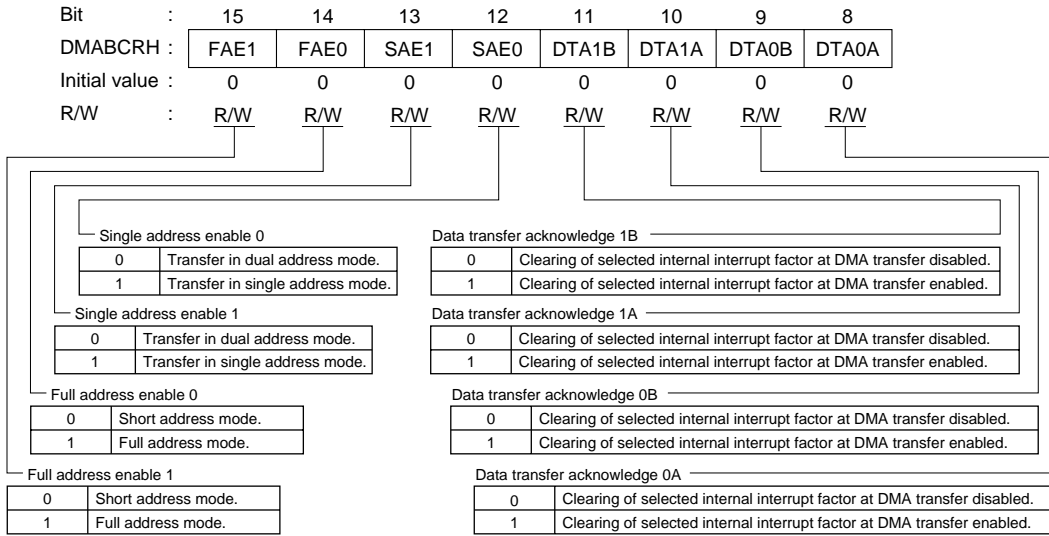
# DMABCR—DMA Band Control Register

H'FF66

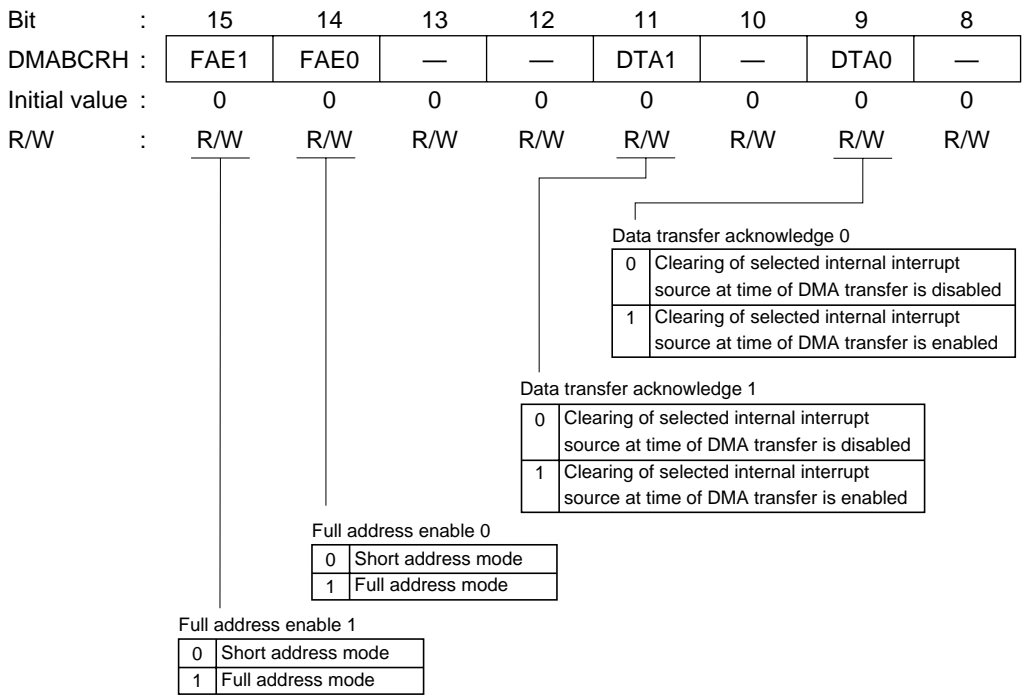
DMAC

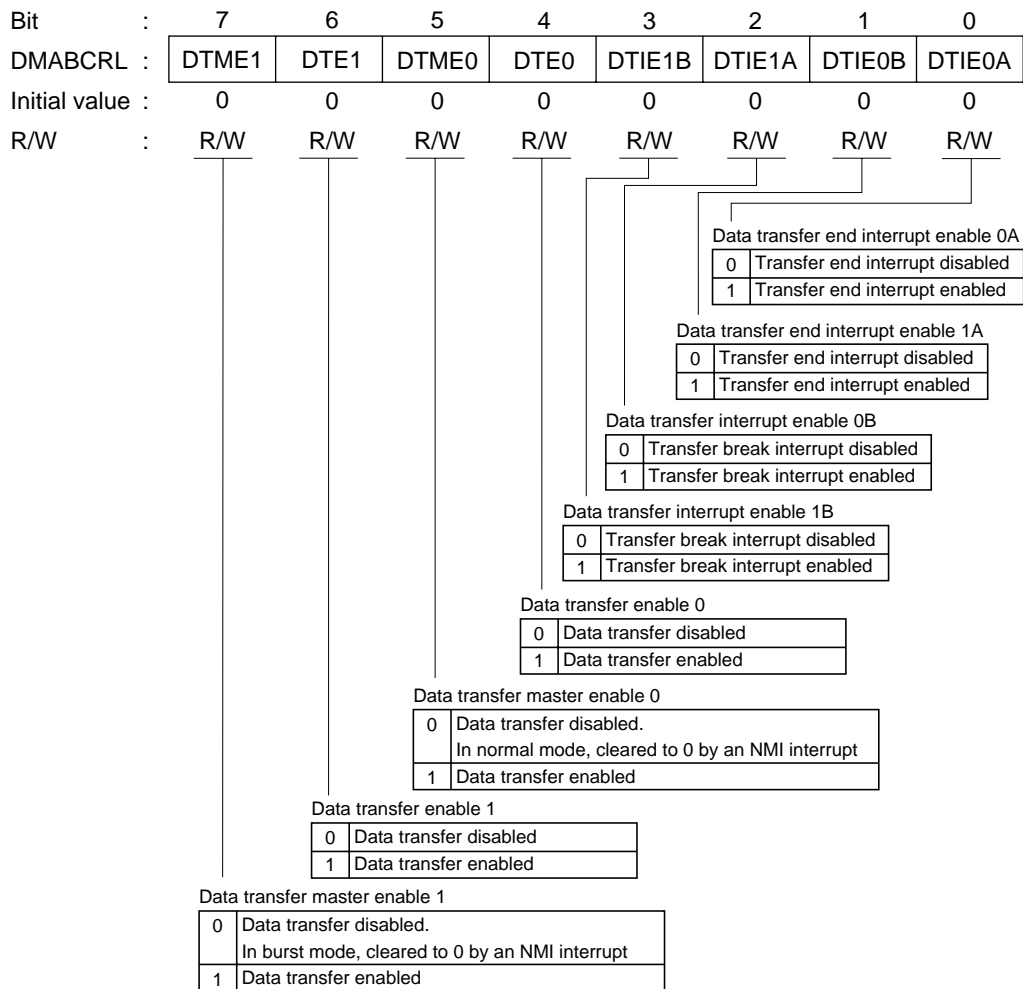
(This function is not available in the H8S/2695.)

## Short address mode



**Full address mode**







**TCSR0—Timer Control/Status Register 0**

**H'FF74 (W), H'FF74 (R)**

**WDT0**

Bit	7	6	5	4	3	2	1	0
	OVF	WT/IT	TME	—	—	CKS2	CKS1	CKS0
Initial value	0	0	0	1	1	0	0	0
R/W	R/(W)*	R/W	R/W	—	—	R/W	R/W	R/W

Clock select 2 to 0  
**WDT0 input clock select**

CKS2	CKS1	CKS0	Clock	Overflow cycle* (when $\phi = 25\text{MHz}$ )
0	0	0	$\phi/2$	20.4 $\mu\text{s}$
		1	$\phi/64$	652.8 $\mu\text{s}$
	1	0	$\phi/128$	1.3 ms
		1	$\phi/512$	5.2 ms
1	0	0	$\phi/2048$	20.9 ms
		1	$\phi/8192$	83.6 ms
	1	0	$\phi/32768$	334.2 ms
		1	$\phi/131072$	1.34 s

Note: \* The overflow cycle starts when TCNT starts counting from H'00 and ends when an overflow occurs.

Timer enable

0	Initializes TCNT to H'00 and disables the counting operation.
1	TCNT performs counting operation.

Timer mode select

0	Interval timer mode: Interval timer interrupt (WOVI) request sent to CPU when overflow occurs at TCNT.
1	Watchdog timer mode: WDT0VF signal output externally when overflow occurs at TCNT. *

Note: \* See section 15.2.3, Reset Control/Status Register (RSTCSR), for details of when TCNT overflows in watchdog timer mode.

Overflow flag

0	[Clearing] When 0 is written to OVF bit after reading TCSR when OVF=1.
1	[Setting] When TCNT overflows (changes from H'FF to H'00). When internal reset request generation is selected in watchdog timer mode, OVF is cleared automatically by the internal reset.

Notes: \* Only 0 can be written to these bits (to clear these flags).

TCSR is write-protected by a password to prevent accidental overwriting.  
 For details see section 15.2.5, Notes on Register Access.

**TCNT0—Timer Counter 0** **H'FF74 (W), H'FF75 (R)** **WDT0**  
**TCNT1—Timer Counter 1** **H'FFA2 (W), H'FFA3 (R)** **WDT1**  
(These functions are not available in the H8S/2695.)

Bit	:	7	6	5	4	3	2	1	0
Initial value	:	0	0	0	0	0	0	0	0
R/W	:	R/W	R/W	R/W	R/W	R/W	R/W	R/W	R/W

Note: TCNT is write-protected by a password to prevent accidental overwriting.  
For details see section 15.2.5, Notes on Register Access.

**RSTCSR—Reset Control/Status Register** **H'FF76 (W), H'FF77 (R)** **WDT0**

Bit	:	7	6	5	4	3	2	1	0
		WOVF	RSTE	RSTS	—	—	—	—	—
Initial value	:	0	0	0	1	1	1	1	1
R/W	:	R/(W)*	R/W	R/W	—	—	—	—	—

Reset select

0	Power-on reset.
1	Manual reset.

Reset enable

0	No internal reset on TCNT overflow.*
1	Internal reset performed on TCNT overflow.

Note: \* The LSI is not internally reset, but TCNT and TCSR in WDT are reset.

Watchdog timer overflow flag

0	[Clearing condition] Writing 0 to WOVF after reading RSTCSR when WOVF=1.
1	[Setting condition] When, in watchdog timer mode, TCNT overflows (H'FF→H'00).

Notes: \* Only 0 can be written to these bits (to clear these flags).

RSTCSR is write-protected by a password to prevent accidental overwriting.  
For details see section 15.2.5, Notes on Register Access.

**ICCR0—I<sup>2</sup>C Bus Control Register**

**H'FF78**

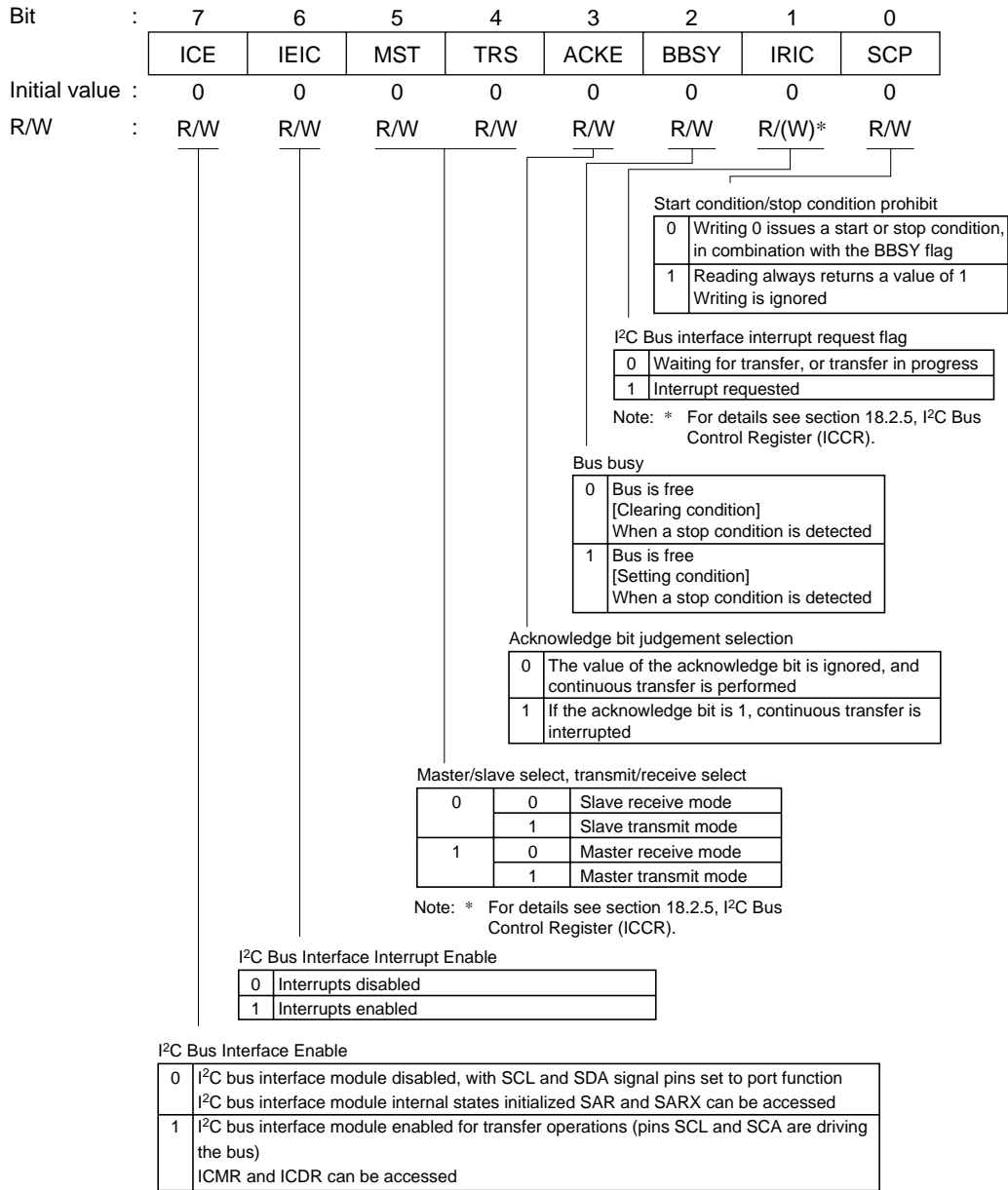
**IIC0**

**ICCR1—I<sup>2</sup>C Bus Control Register**

**H'FF80**

**IIC1**

(These functions are not available in the H8S/2695.)



Note: \* Only 0 can be written, for flag clearing.

**ICSR0—I<sup>2</sup>C Bus Status Register**  
**ICSR1—I<sup>2</sup>C Bus Status Register**

**H'FF79**  
**H'FF81**

**IC0**  
**IC1**

(These functions are not available in the H8S/2695.)

Bit	7	6	5	4	3	2	1	0
	ESTP	STOP	IRTR	AASX	AL	AAS	ADZ	ACKB
Initial value :	0	0	0	0	0	0	0	0
R/W	R/(W)*	R/(W)*	R/(W)*	R/(W)*	R/(W)*	R/(W)*	R/(W)*	R/W

<b>Acknowledge bit</b> 0 When receiving, 0 is output at acknowledge output timing. When transmitting, this bit shows that an acknowledge (0) has not been sent from the receiving device. 1 When receiving, 1 is output at acknowledge output timing. When transmitting, this bit shows that an acknowledge (1) has been sent from the receiving device.	
<b>General call address confirmation flag</b> 0 General call address not confirmed [Clearing conditions] (1) When data is written to ICDR (when sending), or when data is read from ICDR (when receiving) (2) When 0 is written after reading ADZ=1 (3) In master mode 1 General call address confirmation [Setting condition] • When general call address is detected in slave receive mode and FSX = 0 or FS = 0.	
<b>Slave address confirmation flag</b> 0 Slave address or general call address not confirmed [Clearing conditions] (1) When data is written to ICDR (when sending), or when data is read from ICDR (when receiving) (2) When 0 is written after reading AAS=1 (3) In master mode 1 Slave address or general call address confirmed [Setting condition] • When slave address or general call address is detected in slave receive mode and FS = 0.	
<b>Arbitration lost flag</b> 0 Secure bus. [Clearing conditions] (1) When data is written to ICDR (when sending), or when data is read (when receiving) (2) When 0 is written after reading AL=1 1 Bus arbitration lost [Setting conditions] (1) When there is a mismatch between internal SDA and SDA pin at rise in SCL in master transmit mode (2) When the internal SCL level is HIGH at the fall in SCL in master transmit mode.	
<b>2nd slave address confirmation flag</b> 0 2nd slave address not confirmed [Clearing conditions] (1) When 0 is written after reading AASX=1 (2) When start conditions are detected (3) In master mode 1 2nd slave address confirmed [Setting condition] • When 2nd slave address is detected in slave receive mode and FSX = 0.	
<b>I<sup>2</sup>C bus interface continuous transmit and receive interrupt request flag</b> 0 Transmit wait state, or transmitting [Clearing conditions] (1) When 0 written after reading IRTR=1 (2) When IRIC flag is cleared to 0 1 Continuous transmit state [Setting conditions] • In I <sup>2</sup> C bus interface slave mode When 1 is set in TDRE or RDRF flag when AASX=1. • In other than I <sup>2</sup> C bus interface slave mode When TDRE or RDRF flag is set to 1.	
<b>Normal end condition detection flag</b> 0 No normal end condition [Clearing conditions] (1) When 0 is written after reading STOP=1 (2) When IRIC flag is cleared to 0 1 Normal end condition detected in slave mode in I <sup>2</sup> C bus format [Setting condition] On detection of stop condition on completion of sending frame. • No meaning when in other than slave mode in I <sup>2</sup> C bus format	
<b>Error stop condition detection flag</b> 0 No error stop condition [Clearing conditions] (1) When 0 written after reading ESTP=1 (2) When IRIC flag is cleared to 0 1 Error stop condition detected in slave mode in I <sup>2</sup> C bus format [Setting condition] On detection of stop condition while sending frame. • No meaning when in other than slave mode in I <sup>2</sup> C bus format	

Note: \* Only 0 can be written to these bits (to clear these flags).

**ICDR0—I<sup>2</sup>C Bus Data Register****H'FF7E****IIC0****ICDR1—I<sup>2</sup>C Bus Data Register****H'FF86****IIC1**

(These functions are not available in the H8S/2695.)

Bit	:	7	6	5	4	3	2	1	0
		ICDR7	ICDR6	ICDR5	ICDR4	ICDR3	ICDR2	ICDR1	ICDR0
Initial value	:	—	—	—	—	—	—	—	—
R/W	:	R/W	R/W	R/W	R/W	R/W	R/W	R/W	R/W

**ICDRR**

Bit	:	7	6	5	4	3	2	1	0
		ICDRR7	ICDRR6	ICDRR5	ICDRR4	ICDRR3	ICDRR2	ICDRR1	ICDRR0
Initial value	:	—	—	—	—	—	—	—	—
R/W	:	R	R	R	R	R	R	R	R

**ICDRS**

Bit	:	7	6	5	4	3	2	1	0
		ICDRS7	ICDRS6	ICDRS5	ICDRS4	ICDRS3	ICDRS2	ICDRS1	ICDRS0
Initial value	:	—	—	—	—	—	—	—	—
R/W	:	—	—	—	—	—	—	—	—

**ICDRT**

Bit	:	7	6	5	4	3	2	1	0
		ICDRT7	ICDRT6	ICDRT5	ICDRT4	ICDRT3	ICDRT2	ICDRT1	ICDRT0
Initial value	:	—	—	—	—	—	—	—	—
R/W	:	W	W	W	W	W	W	W	W

**TDRE, RDRF (internal flag)**

Bit	:	—	—
		TDRE	RDRF
Initial value	:	0	0
R/W	:	—	—

**SARX0—2nd Slave Address Register****H'FF7E****IIC0****SARX1—2nd Slave Address Register****H'FF86****IIC1**

(These functions are not available in the H8S/2695.)

Bit	:	7	6	5	4	3	2	1	0
		SVAX6	SVAX5	SVAX4	SVAX3	SVAX2	SVAX1	SVAX0	FSX
Initial value	:	0	0	0	0	0	0	0	1
R/W	:	R/W	R/W	R/W	R/W	R/W	R/W	R/W	R/W
		2nd slave address						Format select X	

**ICMR0—I<sup>2</sup>C Bus Mode Register**

**H'FF7F**

**IIC0**

**ICMR1—I<sup>2</sup>C Bus Mode Register**

**H'FF87**

**IIC1**

(These functions are not available in the H8S/2695.)

Bit	:	7	6	5	4	3	2	1	0
		MLS	WAIT	CKS2	CKS1	CKS0	BC2	BC1	BC0
Initial value	:	0	0	0	0	0	0	0	0
R/W	:	R/W	R/W	R/W	R/W	R/W	R/W	R/W	R/W

Bit counter

Bit 2	Bit 1	Bit 0	Bit/frame	
BC2	BC1	BC0	Clock synchronous serial format	PC bus format
0	0	0	8	9
		1	1	2
	1	0	2	3
1	0	1	3	4
		0	4	5
	1	1	5	6
		0	6	7
		1	7	8

Transmit clock select

SCRX Bit 5, 6	Bit 5	Bit 4	Bit 3	Clock	Transfer rate						
					ICX	CKS2	CKS1	CKS0	φ= 5 MHz	φ= 8 MHz	φ= 10 MHz
0	0	0	0	φ/28	179kHz	286 kHz	357 kHz	571 kHz*	714 kHz*	893 kHz*	1000 kHz*
			1	φ/40	125kHz	200 kHz	250 kHz	400 kHz	500 kHz*	625 kHz*	700 kHz*
		1	0	φ/48	104kHz	167 kHz	208 kHz	333 kHz	417 kHz*	521 kHz*	583 kHz*
	1	0	0	φ/64	78.1kHz	125 kHz	156 kHz	250 kHz	313 kHz	391 kHz	438 kHz*
			1	φ/80	62.5kHz	100 kHz	125 kHz	200 kHz	250 kHz	313 kHz	350 kHz
		1	0	φ/100	50.0kHz	80.0 kHz	100 kHz	160 kHz	200 kHz	250 kHz	280 kHz
1	0	0	0	φ/112	44.6kHz	71.4 kHz	89.3 kHz	143 kHz	179 kHz	223 kHz	250 kHz
			1	φ/128	39.1kHz	62.5 kHz	78.1 kHz	125 kHz	156 kHz	195 kHz	219 kHz
		1	0	φ/156	89.3kHz	143 kHz	179 kHz	286 kHz	357 kHz	446 kHz*	500 kHz*
	1	0	0	φ/80	62.5kHz	100 kHz	125 kHz	200 kHz	250 kHz	313 kHz	350 kHz
			1	φ/96	52.1kHz	83.3 kHz	104 kHz	167 kHz	208 kHz	260 kHz	292 kHz
		1	0	φ/128	39.1kHz	62.5 kHz	78.1 kHz	125 kHz	156 kHz	195 kHz	219 kHz
1	0	0	φ/160	31.3kHz	50.0 kHz	62.5 kHz	100 kHz	125 kHz	156 kHz	175 kHz	
		1	φ/200	25.0kHz	40.0 kHz	50.0 kHz	80.0 kHz	100 kHz	125 kHz	140 kHz	
	1	0	φ/224	22.3kHz	35.7 kHz	44.6 kHz	71.4 kHz	89.3 kHz	112 kHz	125 kHz	
			1	φ/256	19.5kHz	31.3 kHz	39.1 kHz	62.5 kHz	78.1 kHz	97.7 kHz	109 kHz

Note: \* These rates are outside the ranges stipulated in the I<sup>2</sup>C bus interface specifications (normal mode: max. 100 kHz, high-speed mode: max. 400 kHz).

Wait insert bit

0	Send data followed by acknowledge bit.
1	Insert wait between data and acknowledge bit.

MSB-first/LSB-first select

0	MSB first
1	LSB first

**SAR0—Slave Address Register** **H'FF7F** **IIC0**  
**SAR1—Slave Address Register** **H'FF87** **IIC1**  
(These functions are not available in the H8S/2695.)

Bit	:	7	6	5	4	3	2	1	0
		SVA6	SVA5	SVA4	SVA3	SVA2	SVA1	SVA0	FS
Initial value	:	0	0	0	0	0	0	0	0
R/W	:	R/W	R/W	R/W	R/W	R/W	R/W	R/W	R/W

Slave address

Format select

DDCSWR bit 6	SAR bit 0	SARX bit 0	Operating mode
SW	FS	FSX	
0	0	0	I <sup>2</sup> C bus format • SAR and SARX slave addresses recognized
		1	I <sup>2</sup> C bus format (initial value) • SAR slave address recognized • SARX slave address ignored
	1	0	I <sup>2</sup> C bus format • SAR slave address ignored • SARX slave address recognized
		1	Synchronous serial format • SAR and SARX slave addresses ignored
1	—	—	• Must not be set.

---

**ADDRAH—A/D Data Register AH** **H'FF90** **A/D**  
**ADDRAL—A/D Data Register AL** **H'FF91** **A/D**  
**ADDRBH—A/D Data Register BH** **H'FF92** **A/D**  
**ADDRBL—A/D Data Register BL** **H'FF93** **A/D**  
**ADDRCH—A/D Data Register CH** **H'FF94** **A/D**  
**ADDRCL—A/D Data Register CL** **H'FF95** **A/D**  
**ADDRDH—A/D Data Register DH** **H'FF96** **A/D**  
**ADDRDL—A/D Data Register DL** **H'FF97** **A/D**

Bit	:	15	14	13	12	11	10	9	8	7	6	5	4	3	2	1	0
		AD9	AD8	AD7	AD6	AD5	AD4	AD3	AD2	AD1	AD0	—	—	—	—	—	—
Initial value	:	0	0	0	0	0	0	0	0	0	0	0	0	0	0	0	0
R/W	:	R	R	R	R	R	R	R	R	R	R	R	R	R	R	R	R

ADCSR—A/D Control/Status Register

H'FF98

A/D

Bit	7	6	5	4	3	2	1	0
	ADF	ADIE	ADST	SCAN	CH3	CH2	CH1	CH0
Initial value :	0	0	0	0	0	0	0	0
R/W	R/(W)*	R/W	R/W	R/W	R/W	R/W	R/W	R/W

Channel select 3	
0	AN8 to AN11 set as group 0 analog input pins, and AN12 to AN15 as group 1 analog input pins.
1	AN0 to AN3 set as group 0 analog input pins, and AN4 to AN7 set as group 1 analog input pins.

Scan mode	
0	Single mode
1	Scan mode

A/D start	
0	A/D conversion disabled.
1	(1) Single mode: A/D conversion starts. Automatically cleared to 0 on completion of conversion on specified channel. (2) Scan mode: A/D conversion starts. The selected channel continues to be sequentially converted until this bit is cleared to 0 by a software, reset, or standby mode is selected, or module stop mode is selected.

A/D interrupt enable	
0	A/D conversion end interrupt (ADI) requests disabled.
1	A/D conversion end interrupt (ADI) requests enabled.

A/D end flag	
0	[Clearing conditions] (1) Writing 0 to the ADF flag after reading ADF=1. (2) When DTC is started by an ADI interrupt and ADDR is read.
1	[Setting conditions] (1) Single mode: On completion of A/D conversion. (2) Scan mode: On completion of conversion of all specified channels.

Channel select 2 to 0

CH3	CH2	CH1	CH0	Single mode (SCAN= 0)	Scan mode (SCAN= 1)
0	0	0	0	AN0	AN0
			1	AN1	AN0, AN1
		1	0	AN2	AN0 to AN2
			1	AN3	AN0 to AN3
	1	0	0	AN4	AN4
			1	AN5	AN4, AN5
		1	0	AN6	AN4 to AN6
			1	AN7	AN4 to AN7
1	0	0	0	AN8	AN8
			1	AN9	AN8, AN9
		1	0	AN10	AN8 to AN10
			1	AN11	AN8 to AN11
	1	0	0	AN12	AN12
			1	AN13	AN12, AN13
		1	0	AN14	AN12 to AN14
			1	AN15	AN12 to AN15

Note: \* Only 0 can be written to these bits (to clear these flags).



**ADCR—A/D Control Register**

**H'FF99**

**A/D**

Bit	:	7	6	5	4	3	2	1	0
		TRGS1	TRGS0	—	—	CKS1	CKS0	—	—
Initial value	:	0	0	1	1	0	0	1	1
R/W	:	R/W	R/W	—	—	R/W	R/W	—	—

Clock select 1, 0

CKS1	CKS0	Description
0	0	Conversion time= 530 states (Max.)
	1	Conversion time= 266 states (Max.)
1	0	Conversion time= 134 states (Max.)
	1	Conversion time= 68 states (Max.)

Time trigger select 1, 0

TRGS1	TRGS0	Description
0	0	Enables starting of A/D conversion by software.
	1	Enables starting of A/D conversion by TPU conversion start trigger.
1	0	Enables starting of A/D conversion by 8-bit timer conversion start trigger.
	1	Enables starting of A/D conversion by external trigger pin (ADTRG).

# TCSR1—Timer Control/Status Register 1

H'FFA2 (W), H'FFA2 (R)

WDT1

(This function is not available in the H8S/2695.)

Bit	7	6	5	4	3	2	1	0
	OVF	WT/IT	TME	PSS	RST/NMI	CKS2	CKS1	CKS0
Initial value	0	0	0	0	0	0	0	0
R/W	R/(W)*	R/W	R/W	R/W	R/W	R/W	R/W	R/W

Clock select 2 to 0

PSS	CKS2	CKS1	CKS0	Clock	Overflow cycle* (when $\alpha=25\text{MHz}$ ) (when $\alpha\text{SUB}=32.768\text{kHz}$ )	
0	0	0	0	$\alpha/2$	20.4 $\mu\text{s}$	
			1	$\alpha/64$	652.8 $\mu\text{s}$	
		1	0	$\alpha/128$	1.3 ms	
	0	1	0	1	$\alpha/512$	5.2 ms
				1	$\alpha/2048$	20.9 ms
			1	0	$\alpha/8192$	83.6 ms
1		0	0	0	$\alpha/32768$	334.2 ms
				1	$\alpha/131072$	1.34 s
			1	0	$\alpha\text{SUB}/2$	15.6 ms
	1	1	0	1	$\alpha\text{SUB}/4$	31.3 ms
				1	$\alpha\text{SUB}/8$	62.5 ms
			1	0	$\alpha\text{SUB}/16$	125 ms
1		0	0	$\alpha\text{SUB}/32$	250 ms	
			1	$\alpha\text{SUB}/64$	500 ms	
		1	0	$\alpha\text{SUB}/128$	1 s	
			1	$\alpha\text{SUB}/256$	2 s	

Note: \* The overflow cycle starts when TCNT starts counting from H'00 and ends when an overflow occurs.

Reset or NMI

0	NMI interrupt request
1	Internal reset request

Prescaler select

0	TCNT counts the divided clock output by the $\alpha$ -based prescaler (PSM).
1	TCNT counts the divided clock output by the $\alpha\text{SUB}$ -based prescaler

Timer enable

0	Initializes TCNT to H'00 and disables the counting operation.
1	TCNT performs counting operation.

Timer mode select

0	Interval timer mode: Interval timer interrupt (WOVI) request sent to CPU when overflow occurs at TCNT.
1	Watchdog timer mode: Reset or NMI interrupt request sent to CPU when overflow occurs at TCNT.

Overflow flag

0	[Clearing conditions] (1) When 0 is written to TME bit (2) When 0 is written to OVF bit after reading TCSR when OVF=1
1	[Setting condition] When TCNT overflows (H'FF → H'00). When internal reset request generation is selected in watchdog timer mode, OVF is cleared automatically by the internal reset.

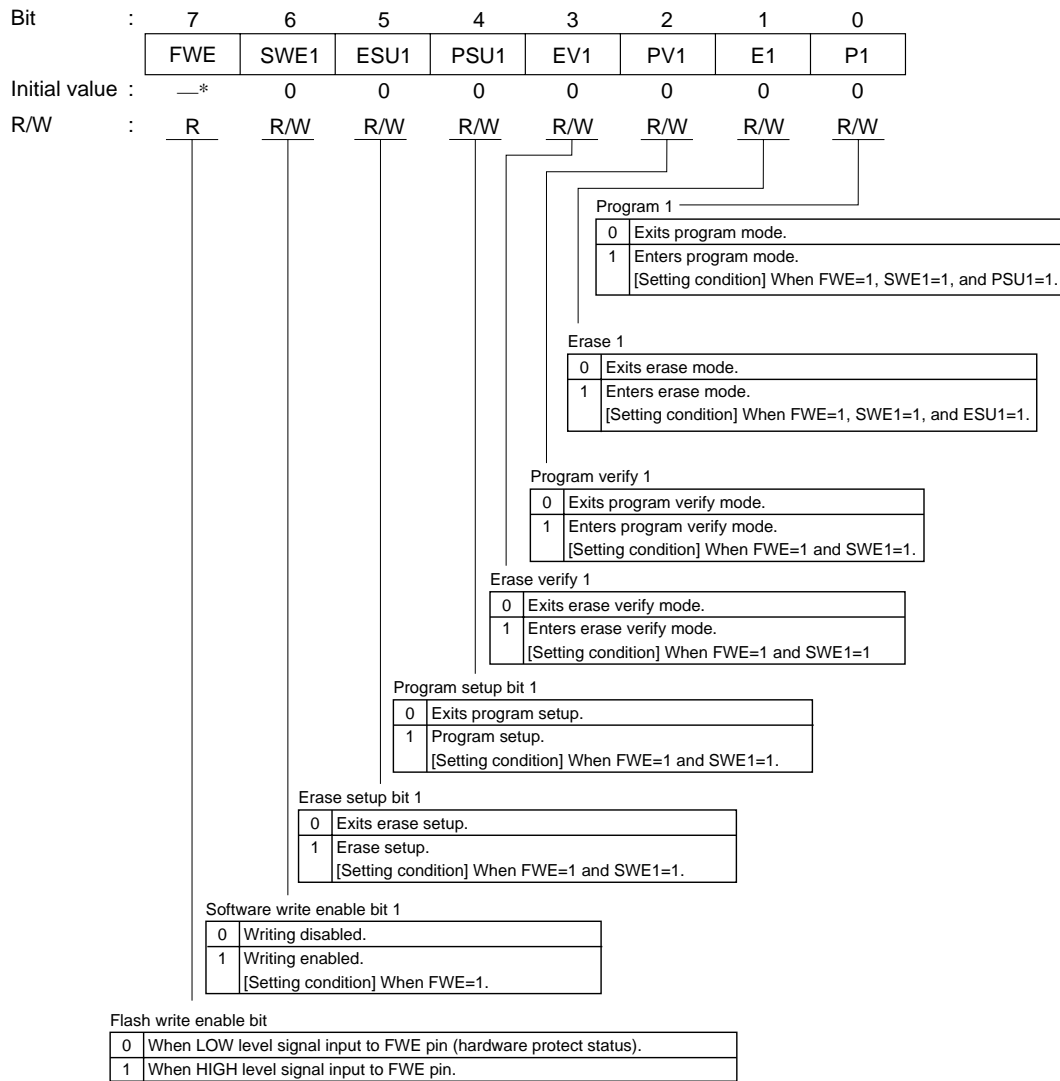
Notes: TCSR is write-protected by a password to prevent accidental overwriting. For details see section 15.2.5, Notes on Register Access.

\* Only 0 can be written to these bits (to clear these flags).

**FLMCR1—Flash Memory Control Register 1**

**H'FFA8**

**FLASH**



Note: \* Determined by the state of the FWE pin.

**FLMCR2—Flash Memory Control Register 2****H'FFA9****FLASH**

Bit	:	7	6	5	4	3	2	1	0
		FLER	—	—	—	—	—	—	—
Initial value	:	0	0	0	0	0	0	0	0
R/W	:	R	—	—	—	—	—	—	—

Flash memory error

0	Flash memory operating normally. Flash memory protection against writing and erasing (error protection) is ignored. [Clearing condition] At a power-on reset and in hardware standby mode.
1	Shows that an error has occurred when writing to or erasing flash memory. Flash memory protection against writing and erasing (error protection) is enabled. [Setting condition] See section 22.8.3, Error Protection.

**EBR1—Erase Block Register 1****H'FFAA****FLASH**

Bit	:	7	6	5	4	3	2	1	0
		EB7	EB6	EB5	EB4	EB3	EB2	EB1	EB0
Initial value	:	0	0	0	0	0	0	0	0
R/W	:	R/W	R/W	R/W	R/W	R/W	R/W	R/W	R/W

**EBR2—Erase Block Register 2****H'FFAB****FLASH**

Bit	:	7	6	5	4	3	2	1	0
		—	—	—	—	EB11	EB10	EB9	EB8
Initial value	:	0	0	0	0	0	0	0	0
R/W	:	R/W	R/W	R/W	R/W	R/W	R/W	R/W	R/W

**FLPWCR—Flash Memory Power Control Register      H'FFAC      FLASH**

Bit	:	7	6	5	4	3	2	1	0
		PDWND	—	—	—	—	—	—	—
Initial value	:	0	0	0	0	0	0	0	0
R/W	:	R/W	R	R	R	R	R	R	R

Power-down disable

0	Transition to flash memory power-down mode enabled
1	Transition to flash memory power-down mode disabled

**PORT1—Port 1 Register      H'FFB0      Port**

Bit	:	7	6	5	4	3	2	1	0
		P17	P16	P15	P14	P13	P12	P11	P10
Initial value	:	—*	—*	—*	—*	—*	—*	—*	—*
R/W	:	R	R	R	R	R	R	R	R

Note: \* Determined by status of pins P17 to P10.

**PORT3—Port 3 Register      H'FFB2      Port**

Bit	:	7	6	5	4	3	2	1	0
		P37	P36	P35	P34	P33	P32	P31	P30
Initial value	:	—*	—*	—*	—*	—*	—*	—*	—*
R/W	:	R	R	R	R	R	R	R	R

Note: \* Determined by status of pins P37 to P30.

**PORT4—Port 4 Register****H'FFB3****Port**

Bit	:	7	6	5	4	3	2	1	0
		P47	P46	P45	P44	P43	P42	P41	P40
Initial value	:	—*	—*	—*	—*	—*	—*	—*	—*
R/W	:	R	R	R	R	R	R	R	R

Note: \* Determined by status of pins P47 to P40.

**PORT7—Port 7 Register****H'FFB6****Port**

Bit	:	7	6	5	4	3	2	1	0
		P77	P76	P75	P74	P73	P72	P71	P70
Initial value	:	—*	—*	—*	—*	—*	—*	—*	—*
R/W	:	R	R	R	R	R	R	R	R

Note: \* Determined by status of pins P77 to P70.

**PORT9—Port 9 Register****H'FFB8****Port**

Bit	:	7	6	5	4	3	2	1	0
		P97	P96	P95	P94	P93	P92	P91	P90
Initial value	:	—*	—*	—*	—*	—*	—*	—*	—*
R/W	:	R	R	R	R	R	R	R	R

Note: \* Determined by status of pins P97 to P90.

**PORTA—Port A Register****H'FFB9****Port**

Bit	:	7	6	5	4	3	2	1	0
		—	—	—	—	PA3	PA2	PA1	PA0
Initial value	:	Undefined	Undefined	Undefined	Undefined	—*	—*	—*	—*
R/W	:	—	—	—	—	R	R	R	R

Note: \* Determined by status of pins PA3 to PA0.

**PORTB—Port B Register****H'FFBA****Port**

Bit	:	7	6	5	4	3	2	1	0
		PB7	PB6	PB5	PB4	PB3	PB2	PB1	PB0
Initial value	:	—*	—*	—*	—*	—*	—*	—*	—*
R/W	:	R	R	R	R	R	R	R	R

Note: \* Determined by status of pins PB7 to PB0.

**PORTC—Port C Register****H'FFBB****Port**

Bit	:	7	6	5	4	3	2	1	0
		PC7	PC6	PC5	PC4	PC3	PC2	PC1	PC0
Initial value	:	—*	—*	—*	—*	—*	—*	—*	—*
R/W	:	R	R	R	R	R	R	R	R

Note: \* Determined by status of pins PC7 to PC0.

**PORTD—Port D Register****H'FFBC****Port**

Bit	:	7	6	5	4	3	2	1	0
		PD7	PD6	PD5	PD4	PD3	PD2	PD1	PD0
Initial value	:	—*	—*	—*	—*	—*	—*	—*	—*
R/W	:	R	R	R	R	R	R	R	R

Note: \* Determined by status of pins PD7 to PD0.

**PORTE—Port E Register****H'FFBD****Port**

Bit	:	7	6	5	4	3	2	1	0
		PE7	PE6	PE5	PE4	PE3	PE2	PE1	PE0
Initial value	:	—*	—*	—*	—*	—*	—*	—*	—*
R/W	:	R	R	R	R	R	R	R	R

Note: \* Determined by status of pins PE7 to PE0.

**PORTF—Port F Register****H'FFBE****Port**

Bit	:	7	6	5	4	3	2	1	0
		PF7	PF6	PF5	PF4	PF3	PF2	PF1	PF0
Initial value	:	—*	—*	—*	—*	—*	—*	—*	—*
R/W	:	R	R	R	R	R	R	R	R

Note: \* Determined by status of pins PF7 to PF0.

**PORTG—Port G Register****H'FFBF****Port**

Bit	:	7	6	5	4	3	2	1	0
		—	—	—	PG4	PG3	PG2	PG1	PG0
Initial value	:	Undefined	Undefined	Undefined	—*	—*	—*	—*	—*
R/W	:	—	—	—	R	R	R	R	R

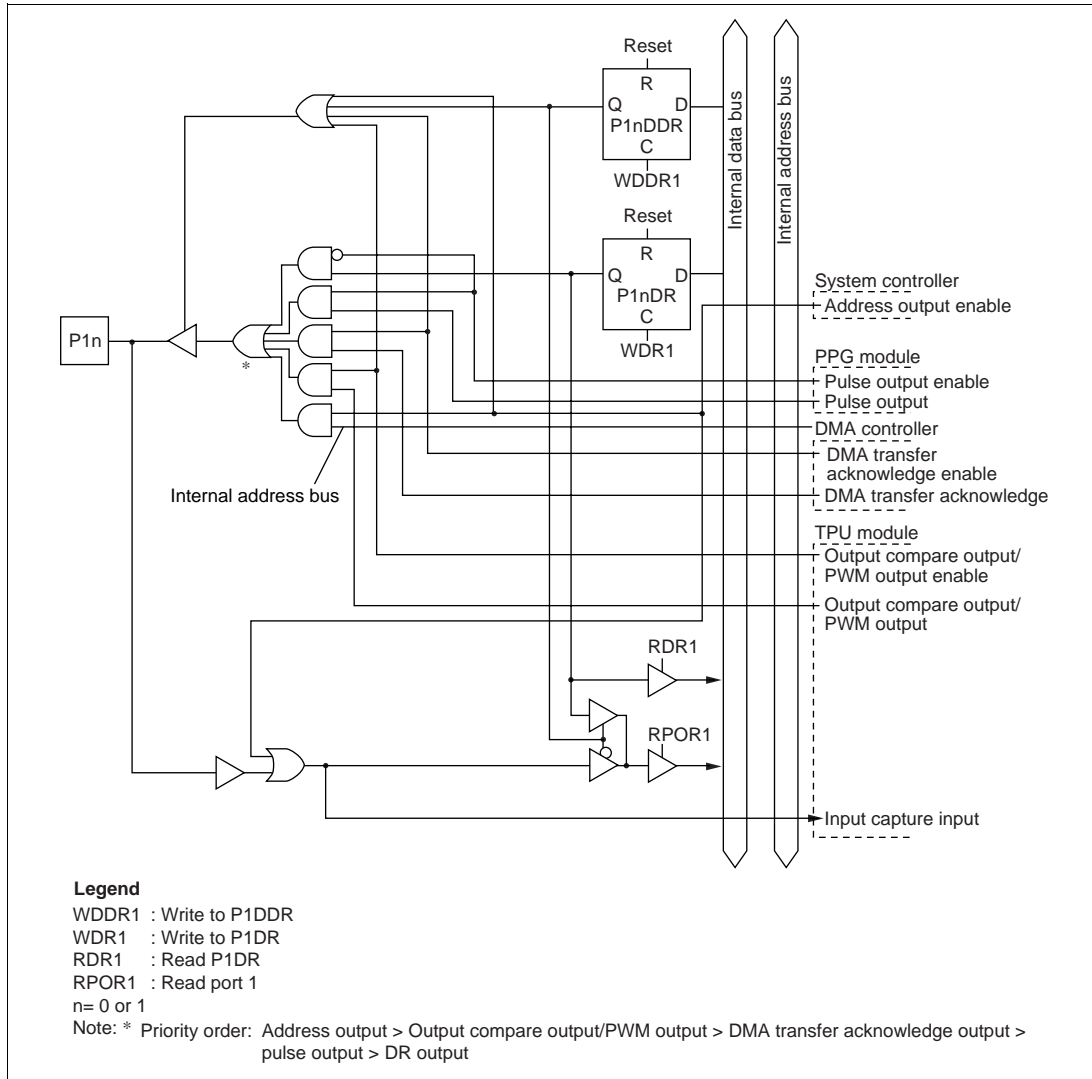
Note: \* Determined by status of pins PG4 to PG0.



## Appendix C I/O Port Block Diagrams

C.1 to C.12 are I/O port block diagrams for the H8S/2633, H8S/2632, H8S/2631, H8S/2633F, and H8S/2633R. C.13 to C.24 are I/O port block diagrams for the H8S/2695.

### C.1 Port 1 Block Diagram



**Figure C-1 (a) Port 1 Block Diagram (Pins P10 and P11)**

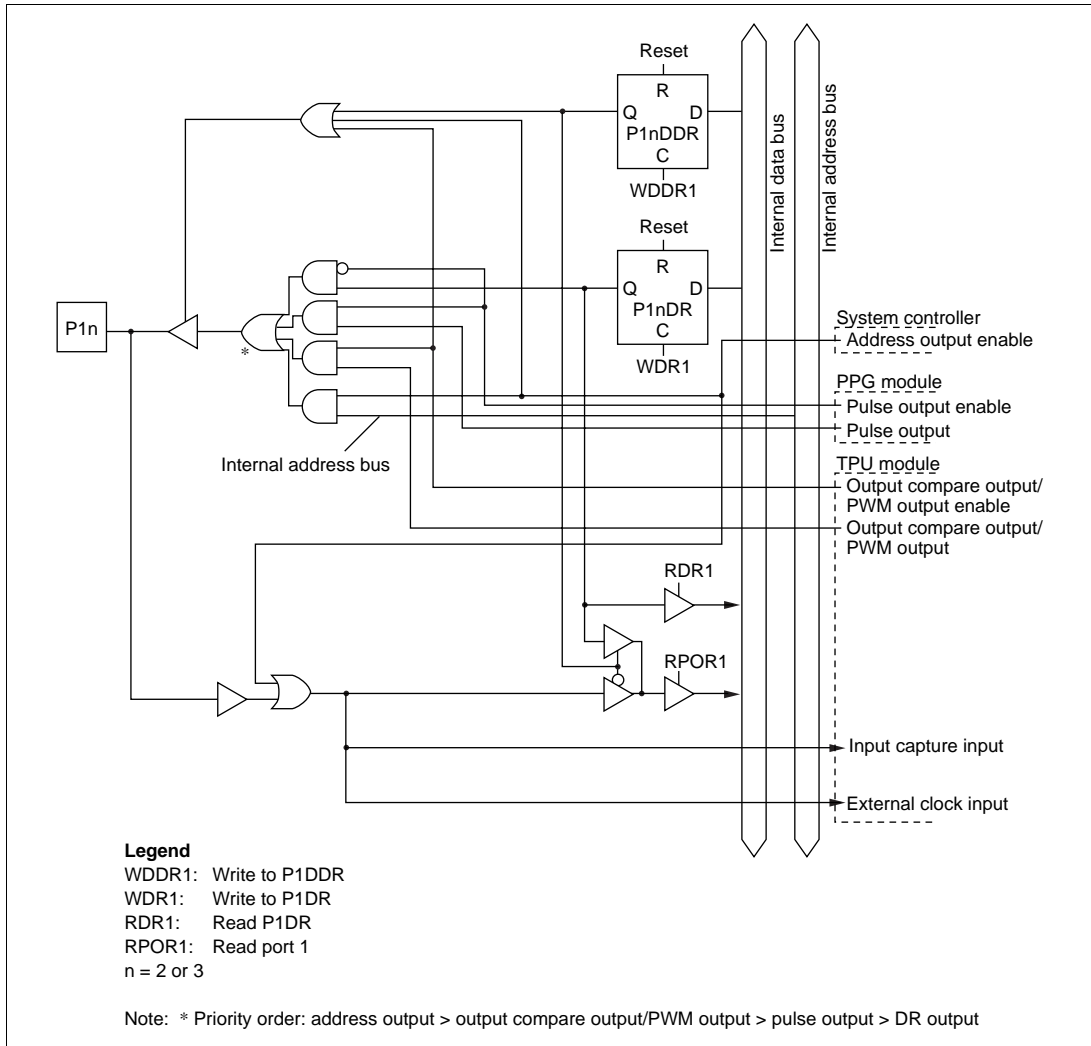


Figure C-1 (b) Port 1 Block Diagram (Pins P12 and P13)

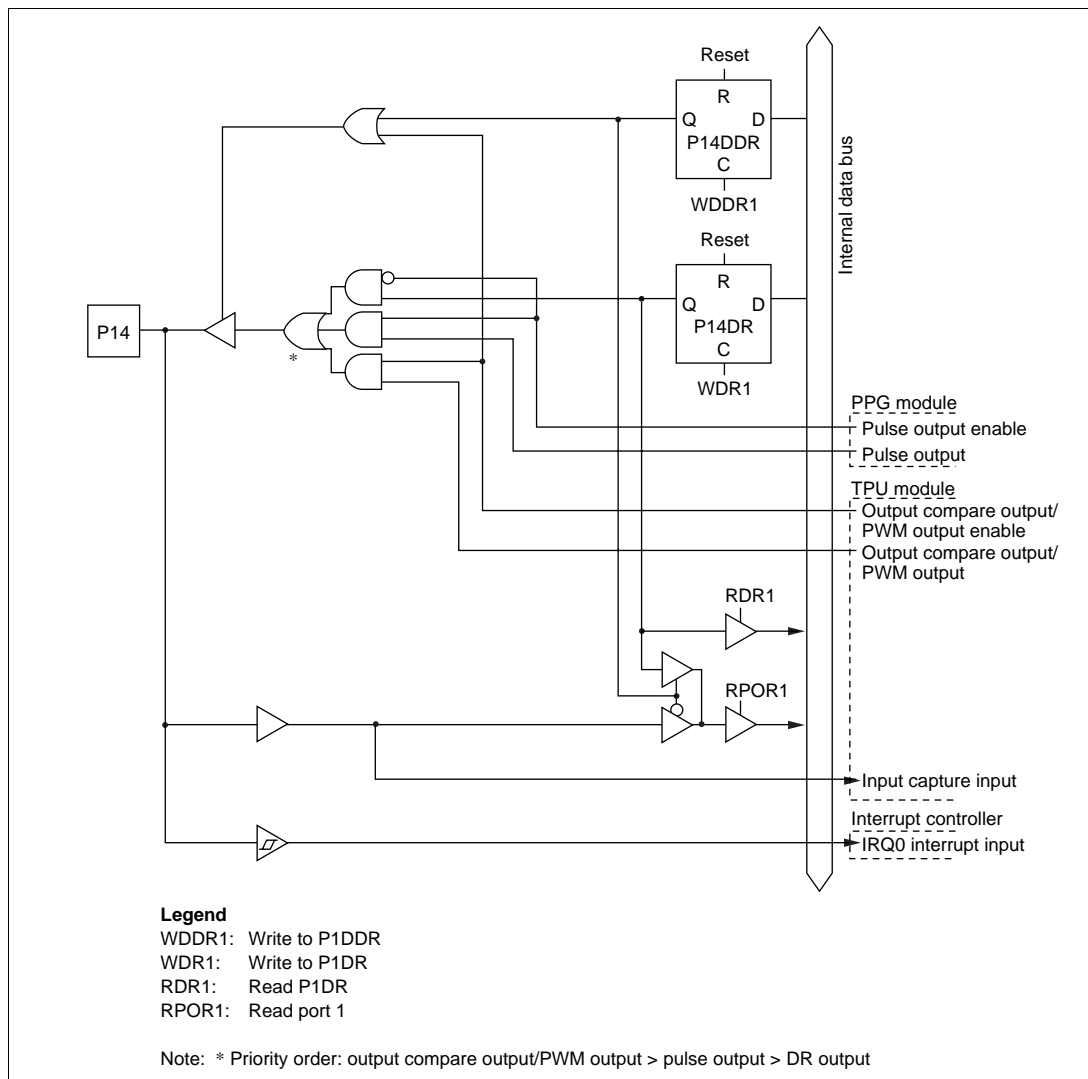
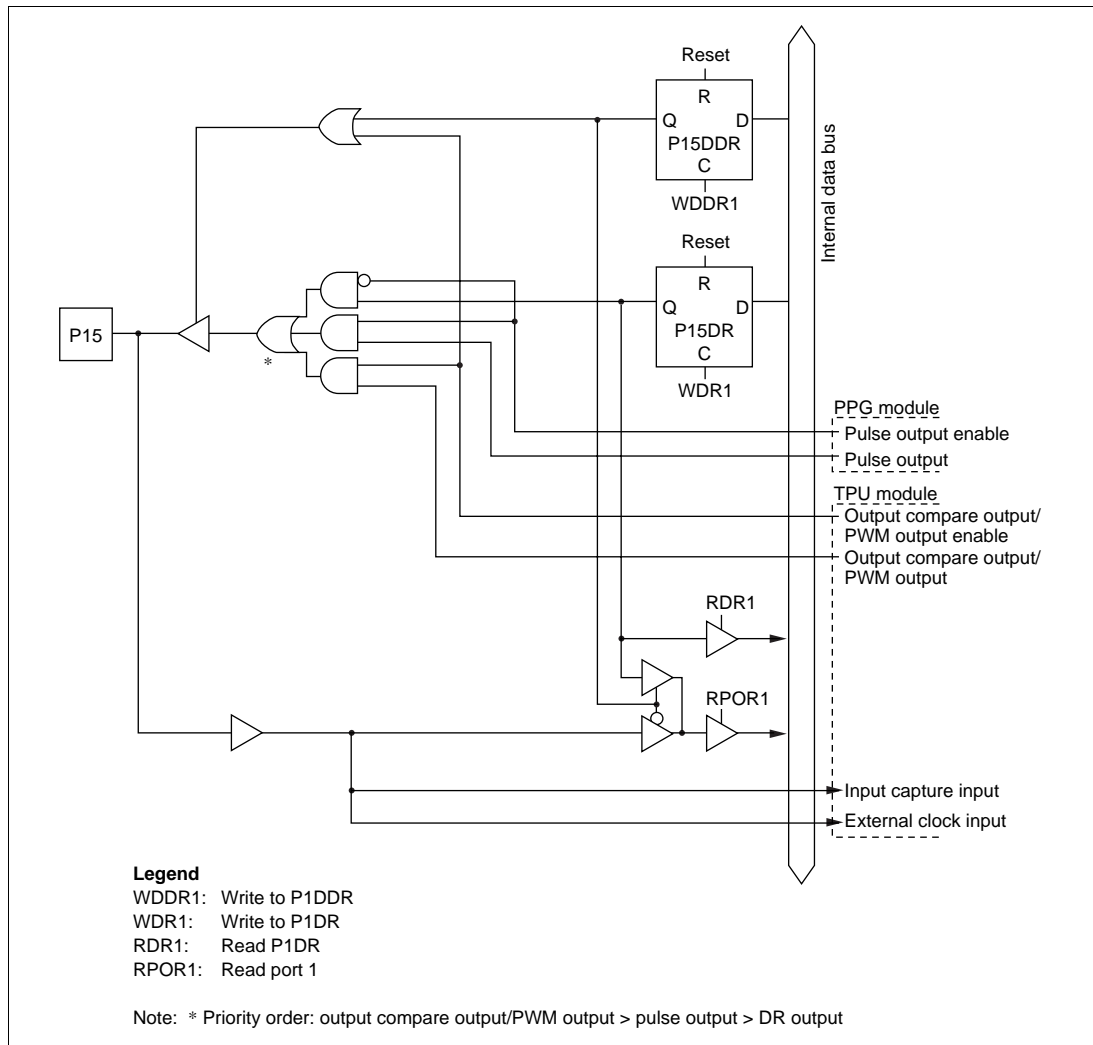
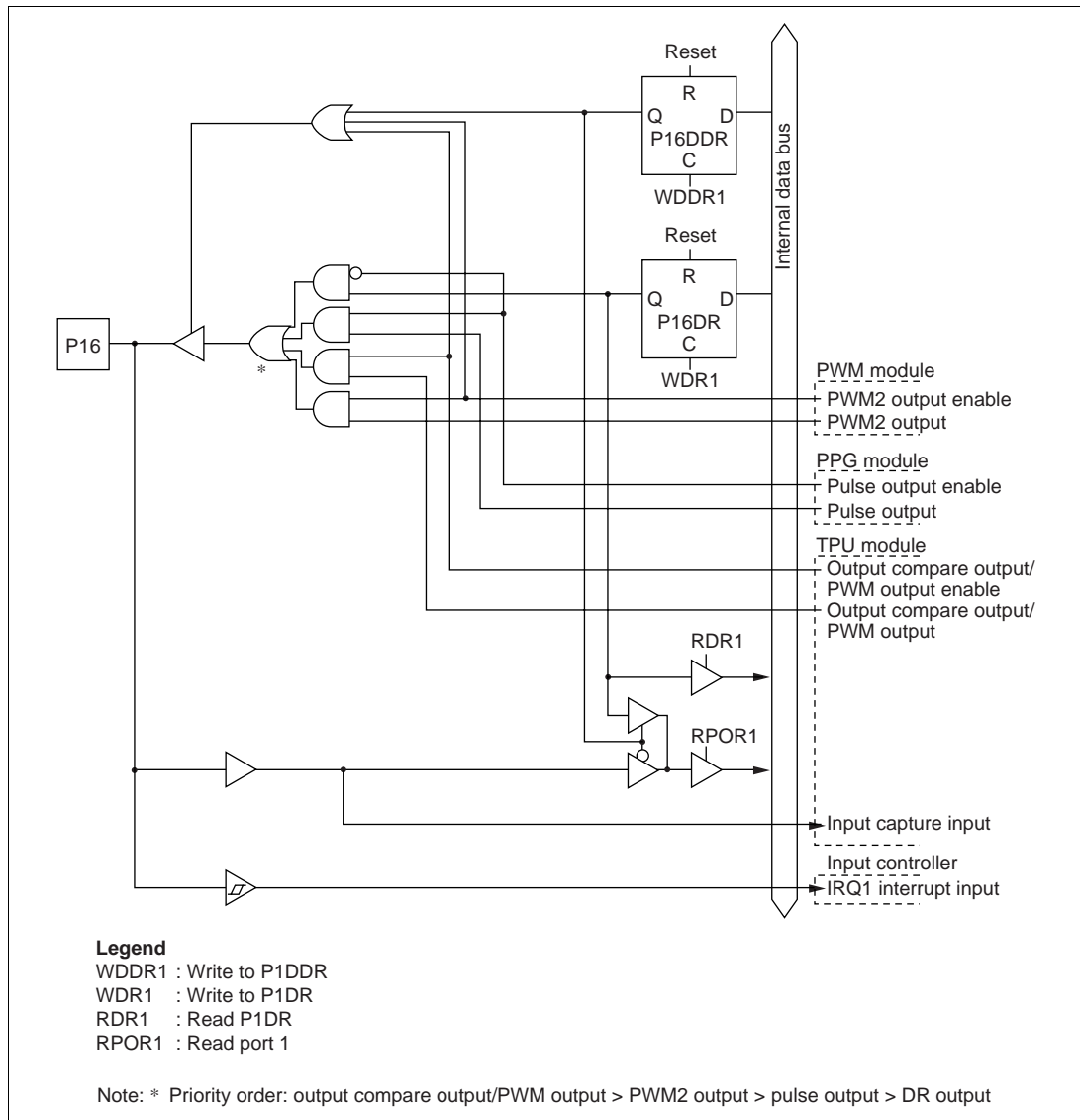


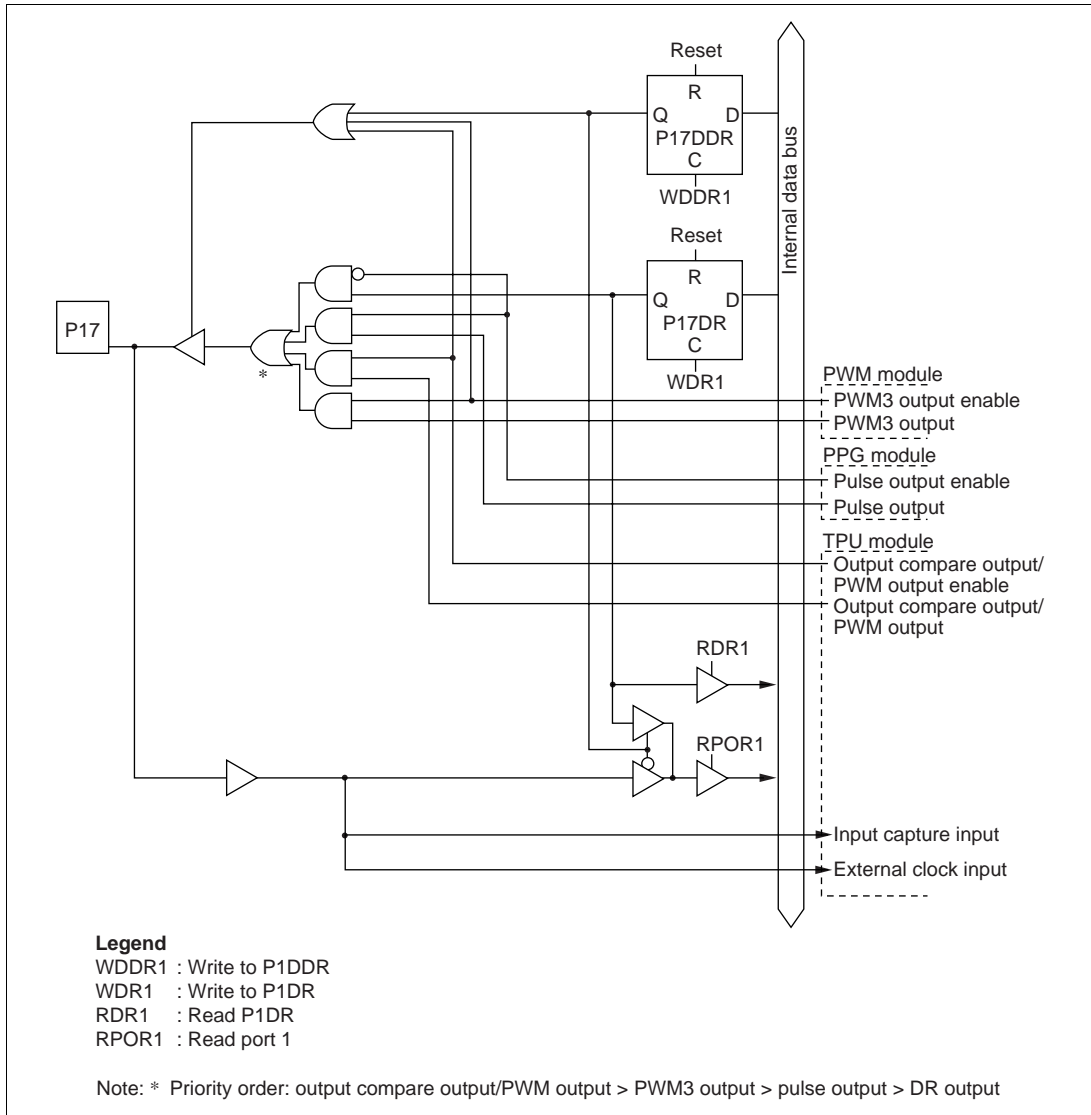
Figure C-1 (c) Port 1 Block Diagram (Pin P14)



**Figure C-1 (d) Port 1 Block Diagram (Pin P15)**



**Figure C-1 (e) Port 1 Block Diagram (Pin P16)**



**Figure C-1 (f) Port 1 Block Diagram (Pin P17)**

## C.2 Port 3 Block Diagram

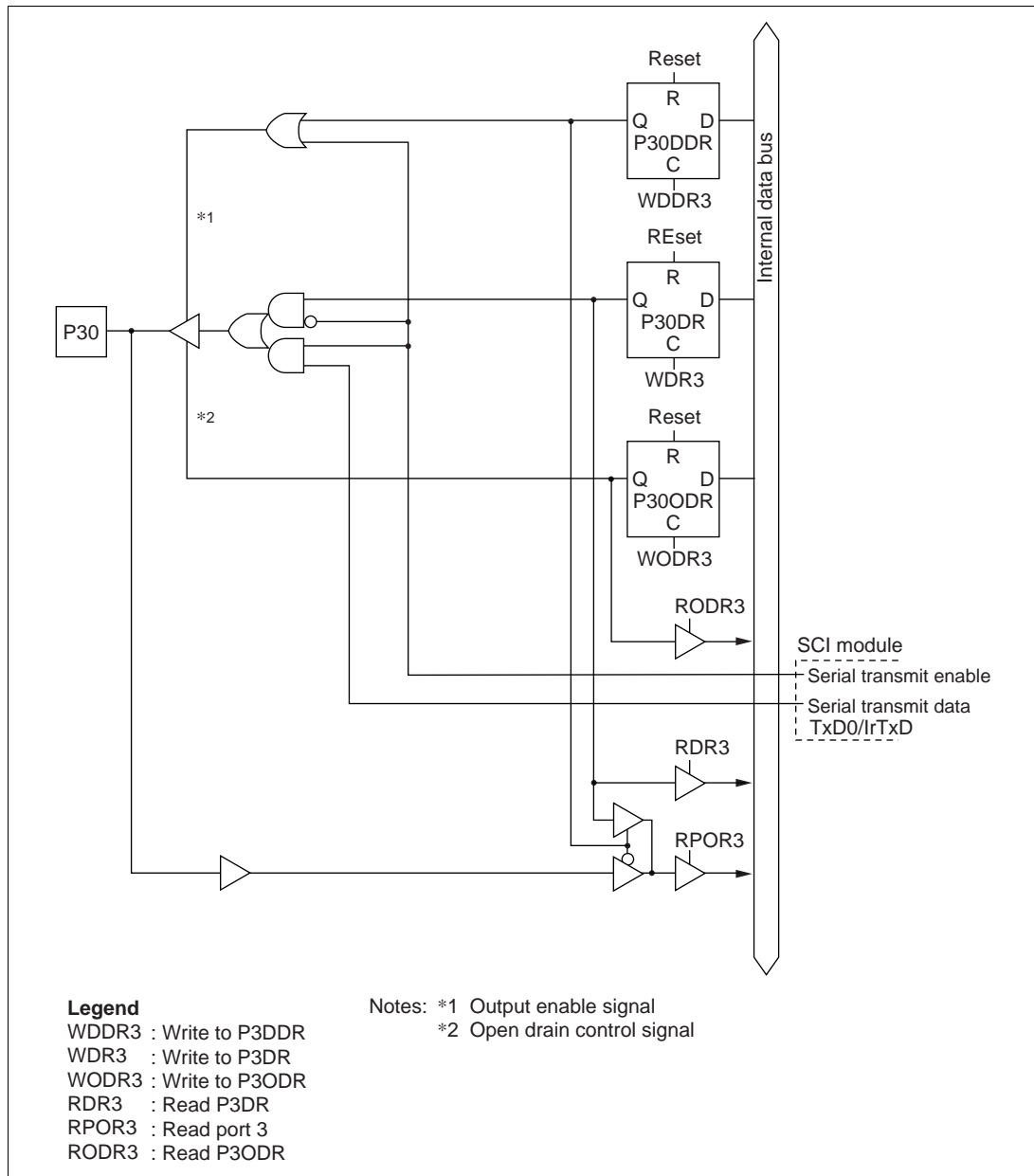
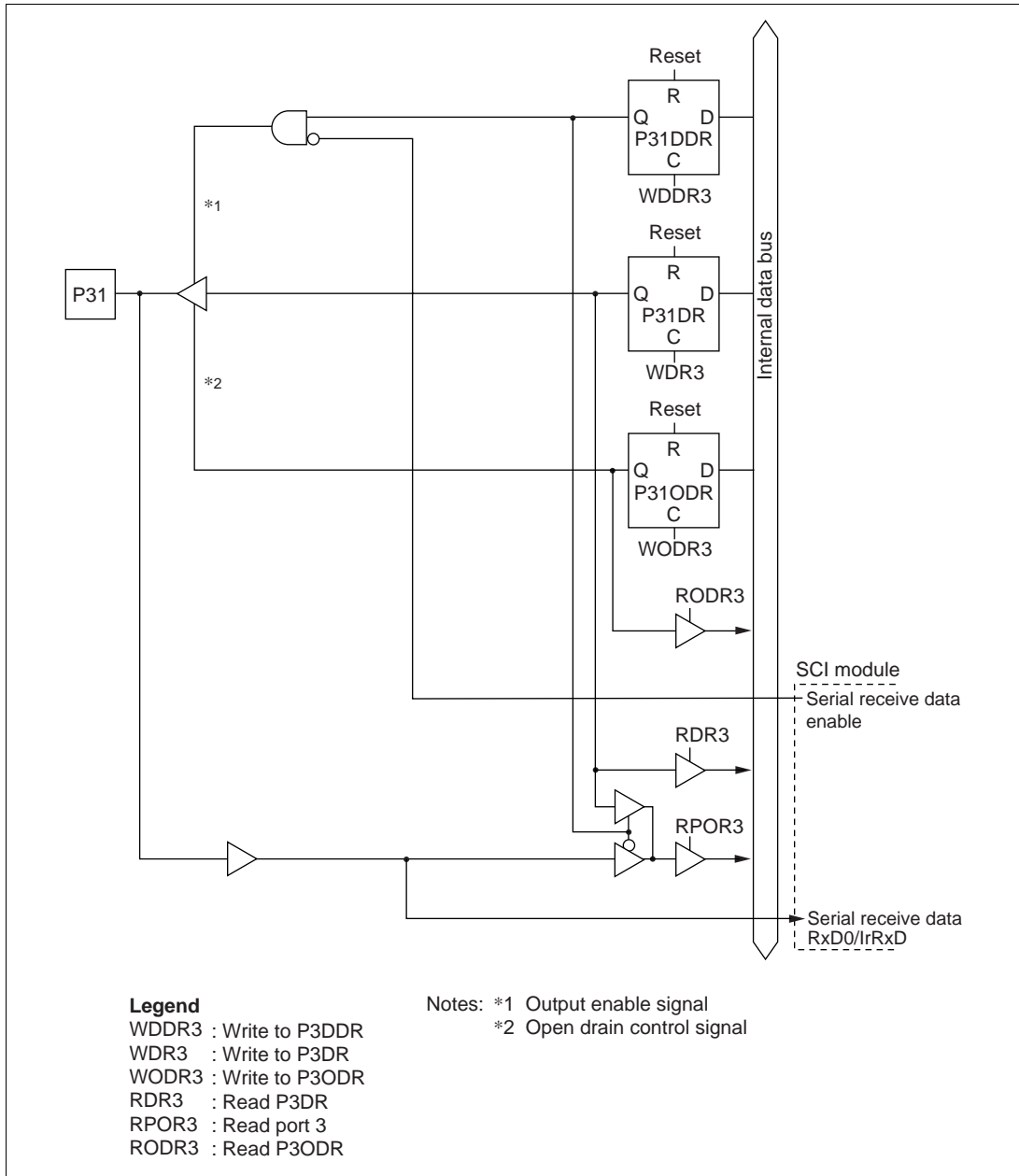


Figure C-2 (a) Port 3 Block Diagram (Pin P30)



**Figure C-2 (b) Port 3 Block Diagram (Pin P31)**



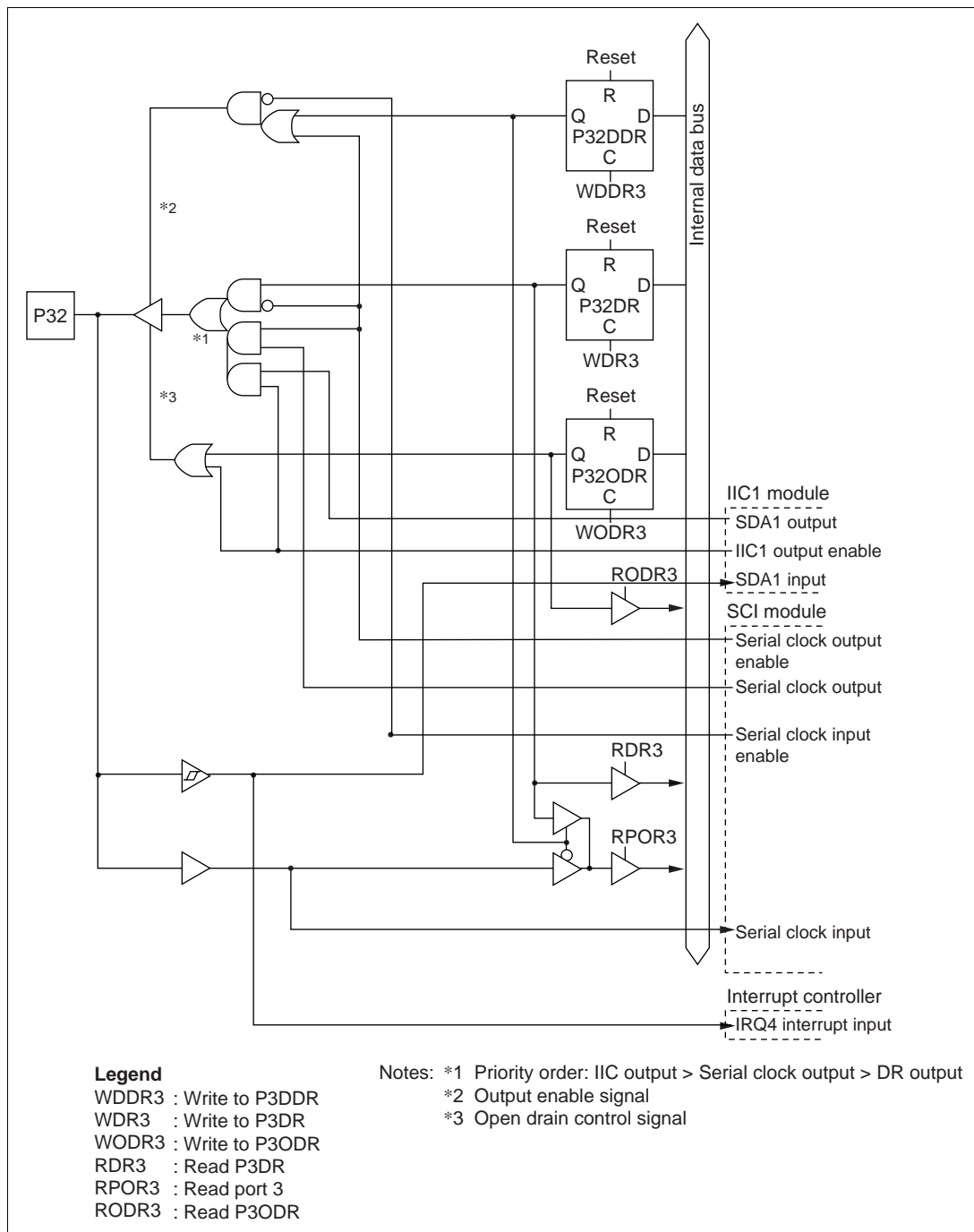


Figure C-2 (c) Port 3 Block Diagram (Pin P32)

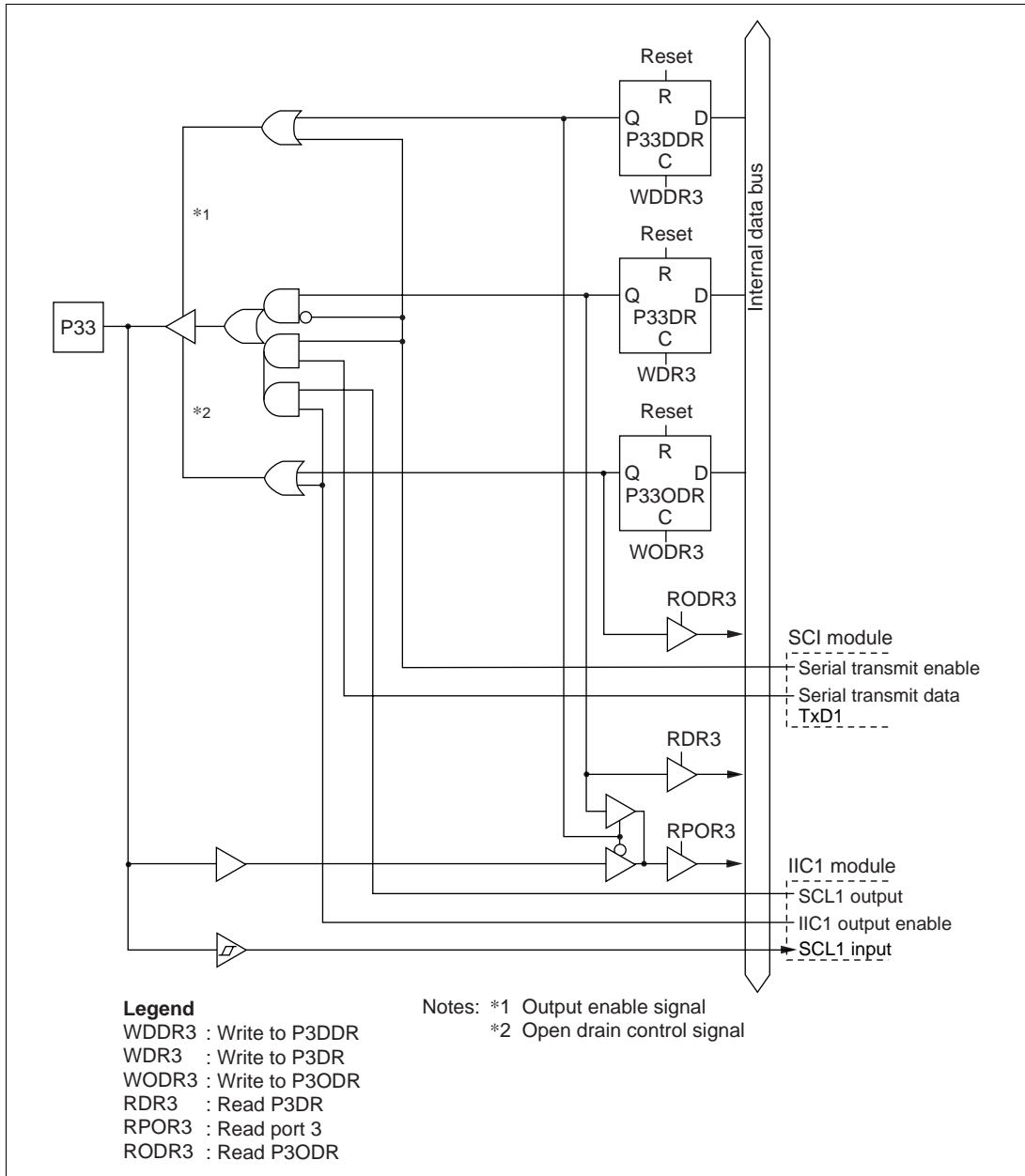


Figure C-2 (d) Port 3 Block Diagram (Pin P33)

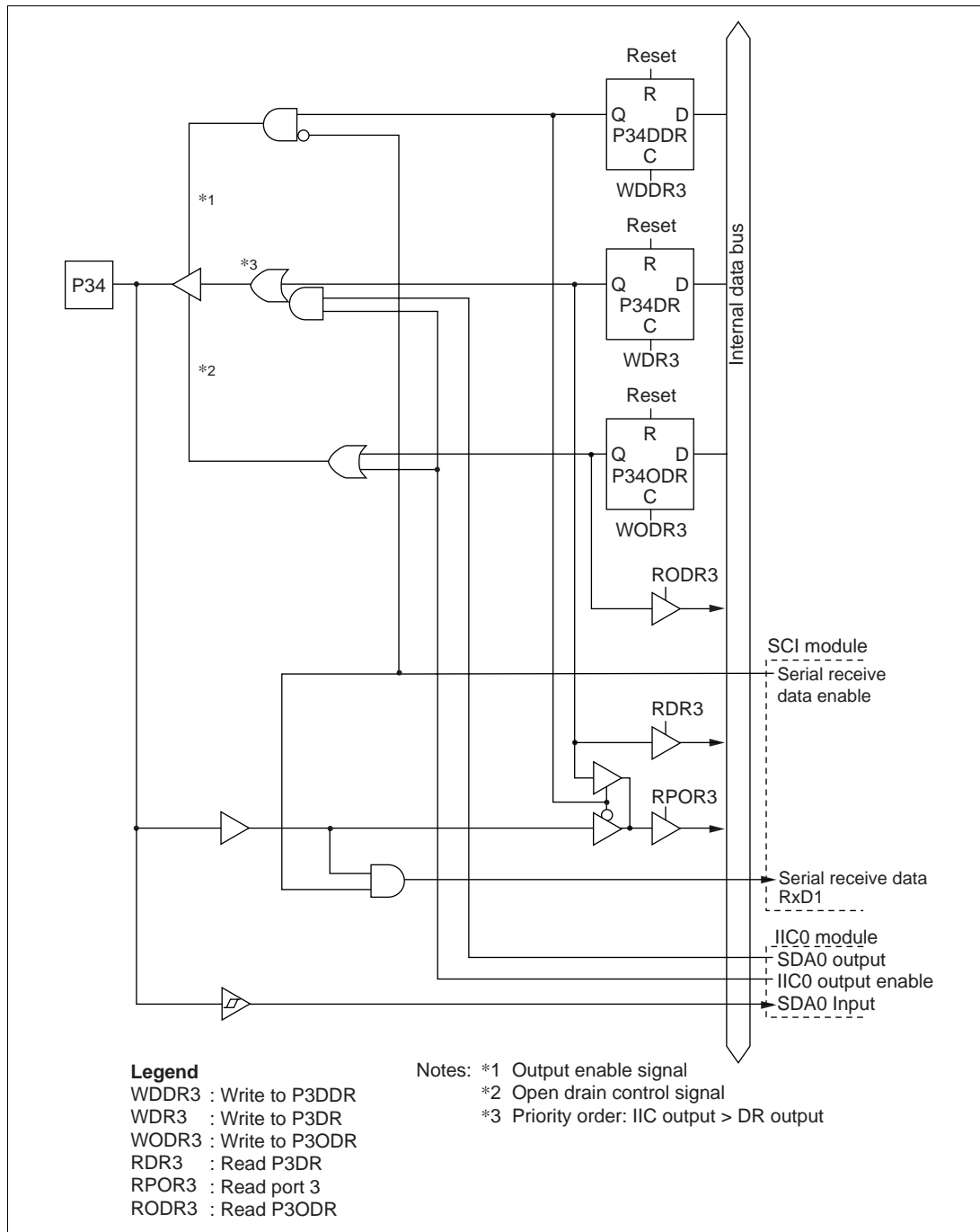
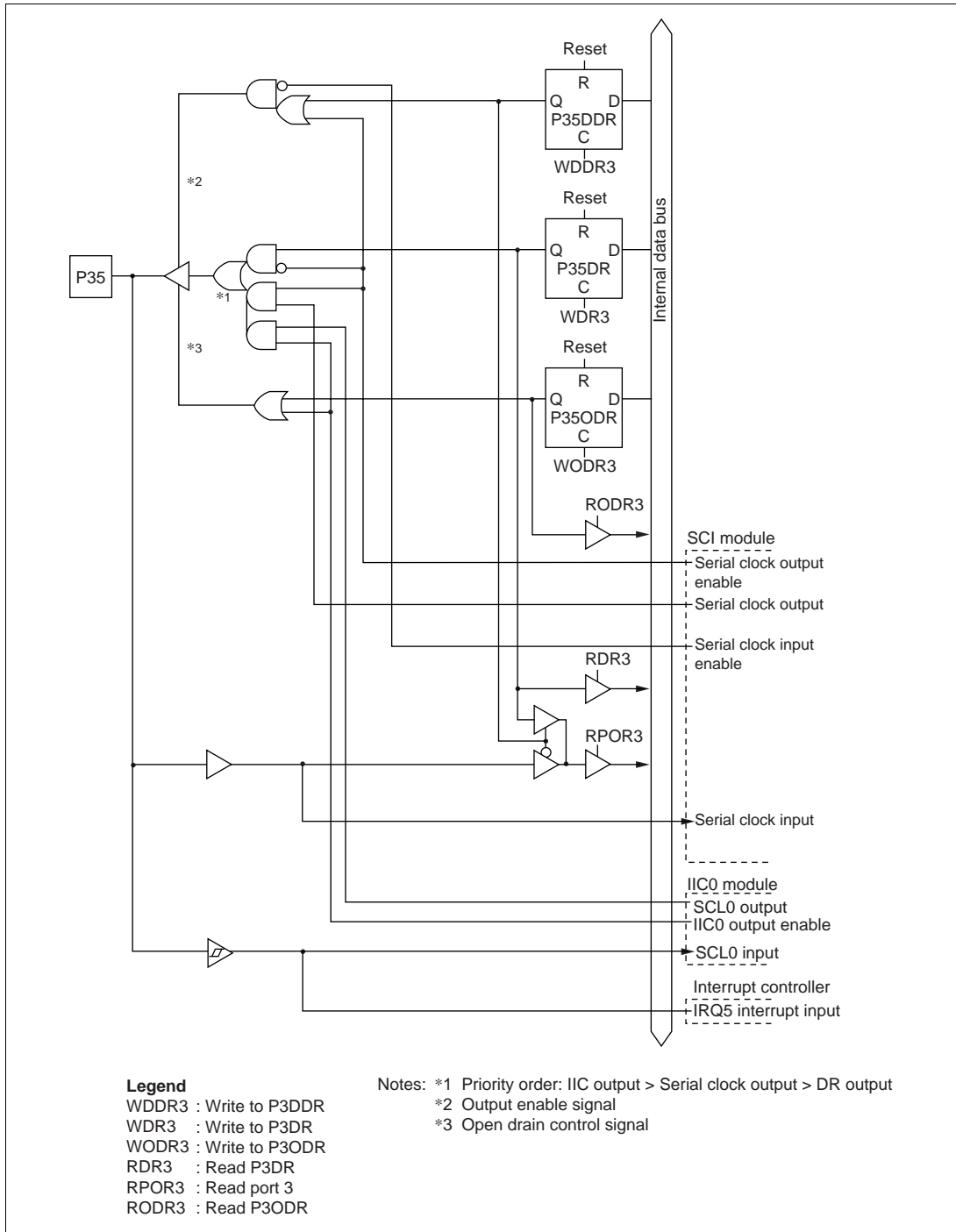
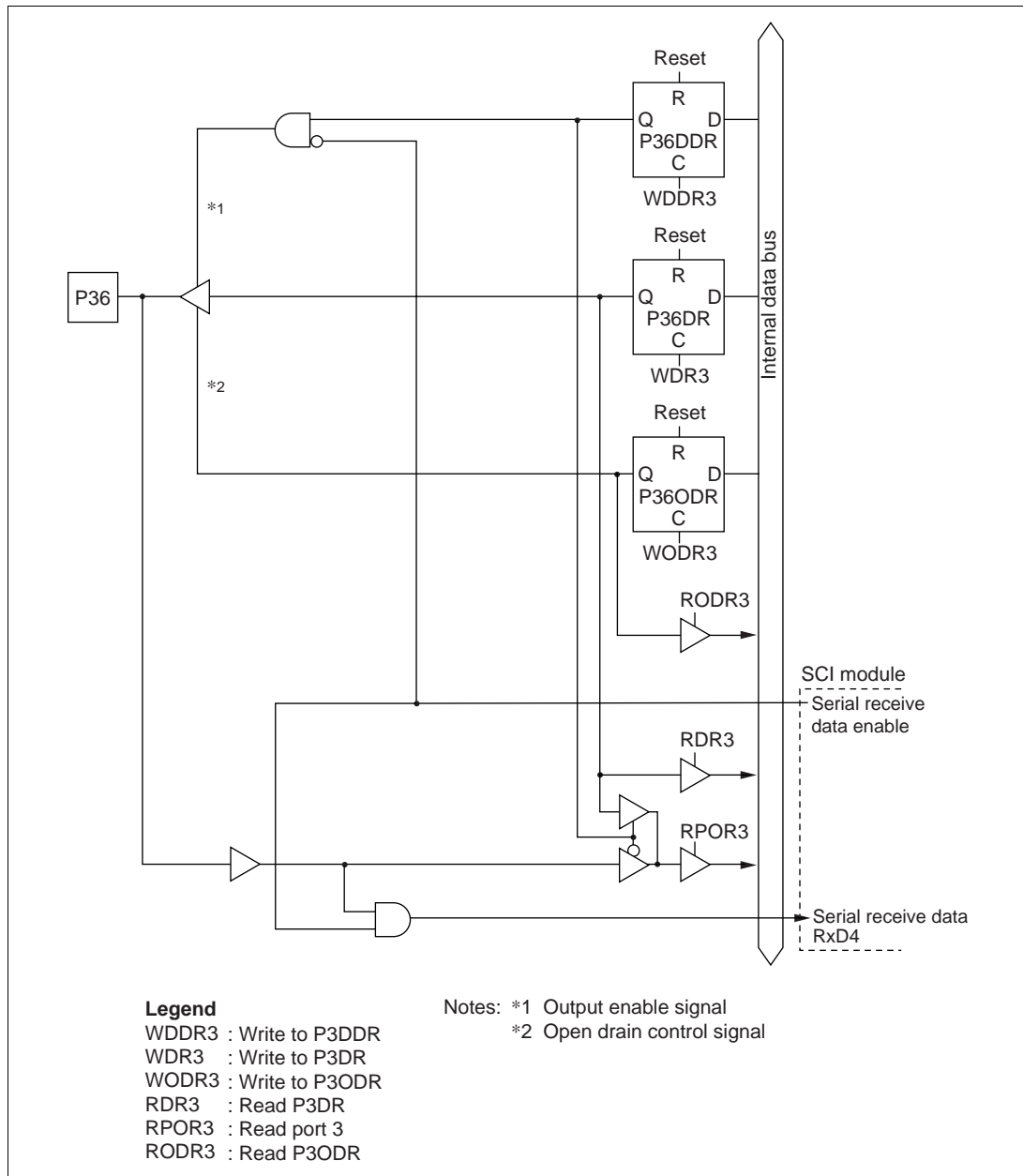


Figure C-2 (e) Port 3 Block Diagram (Pin P34)



**Figure C-2 (f) Port 3 Block Diagram (Pin P35)**



**Figure C-2 (g) Port 3 Block Diagram (Pin P36)**

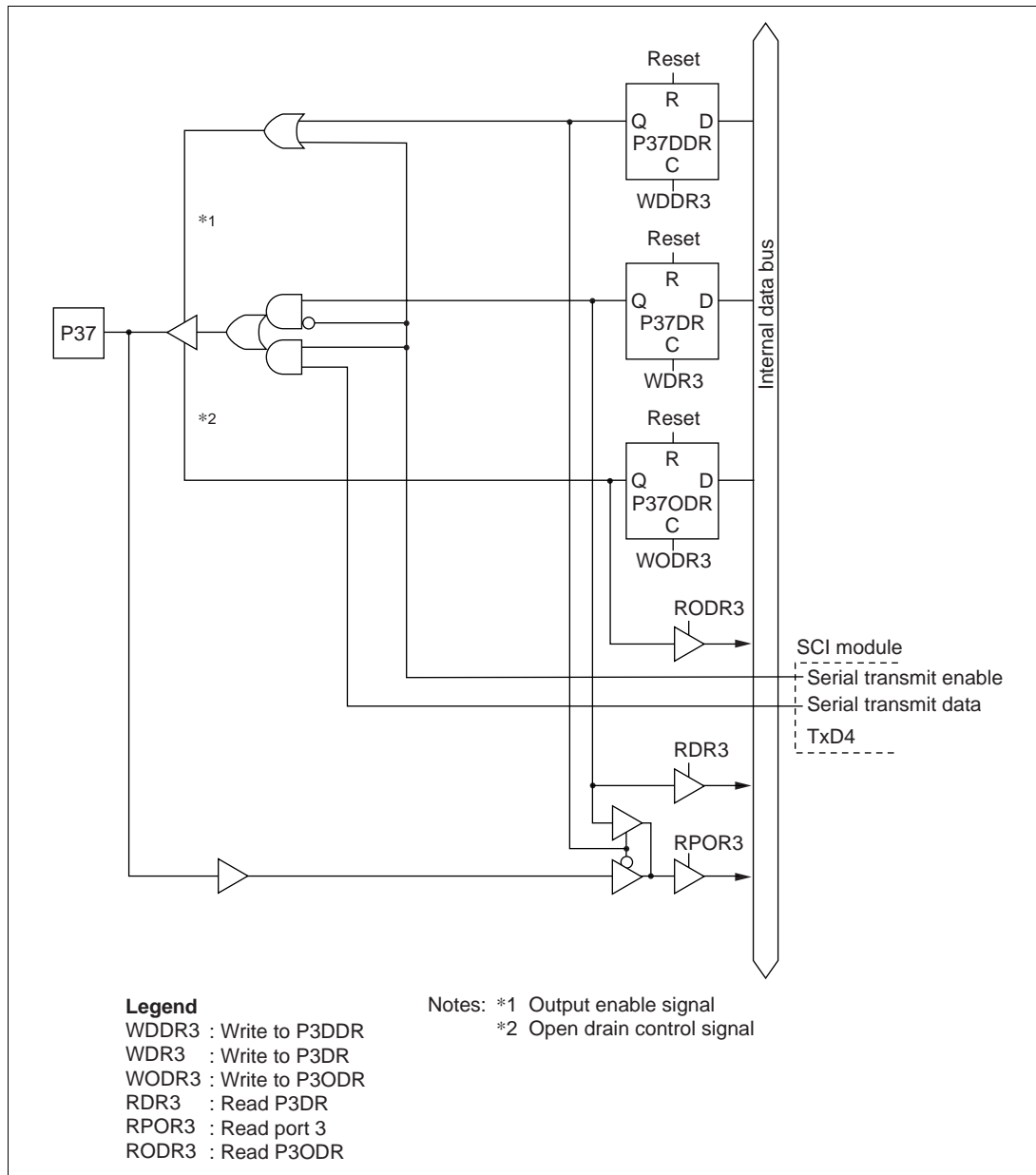


Figure C-2 (h) Port 3 Block Diagram (Pin P37)

### C.3 Port 4 Block Diagram

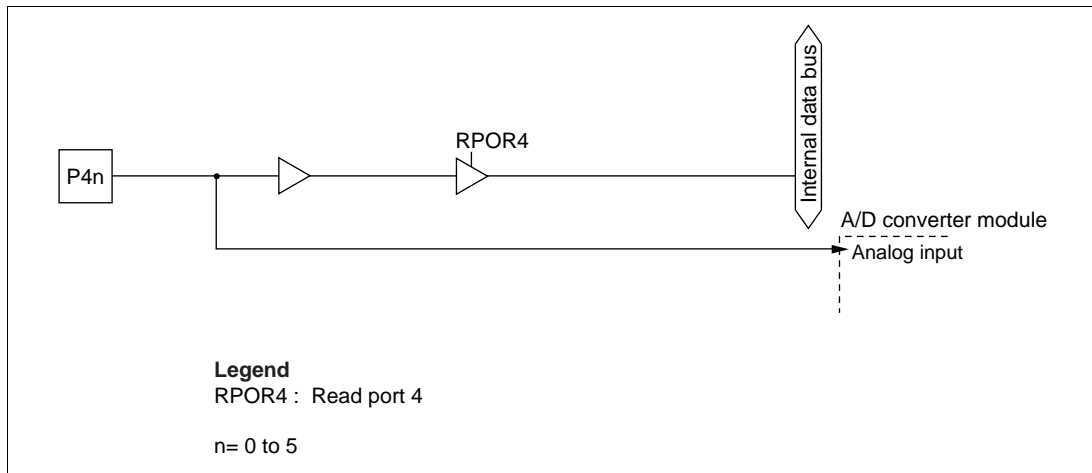


Figure C-3 (a) Port 4 Block Diagram (Pins P40 to P45)

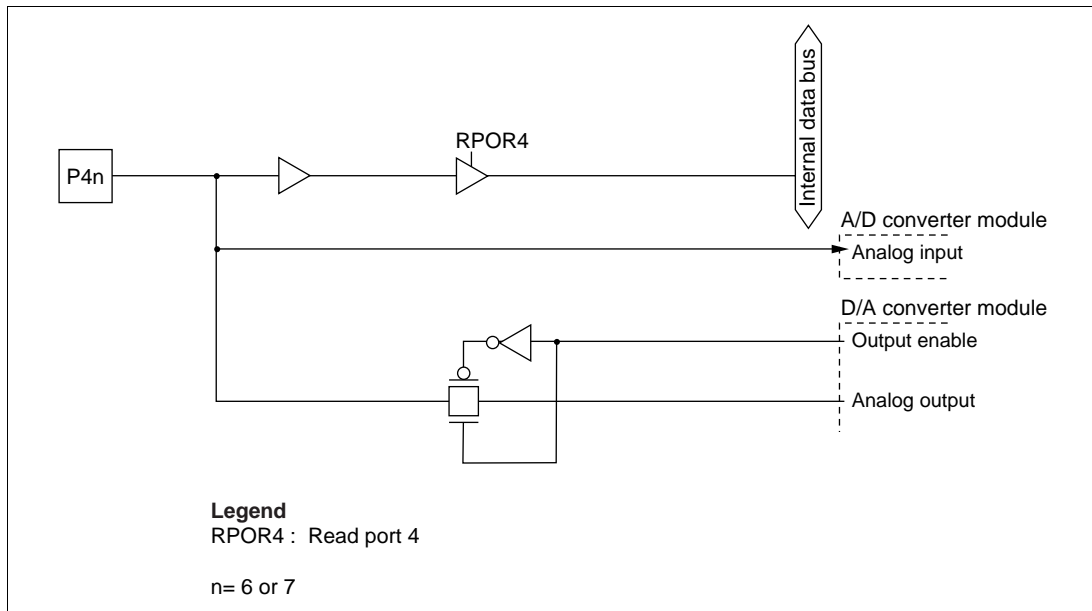


Figure C-3 (b) Port 4 Block Diagram (Pins P46 and P47)

## C.4 Port 7 Block Diagram

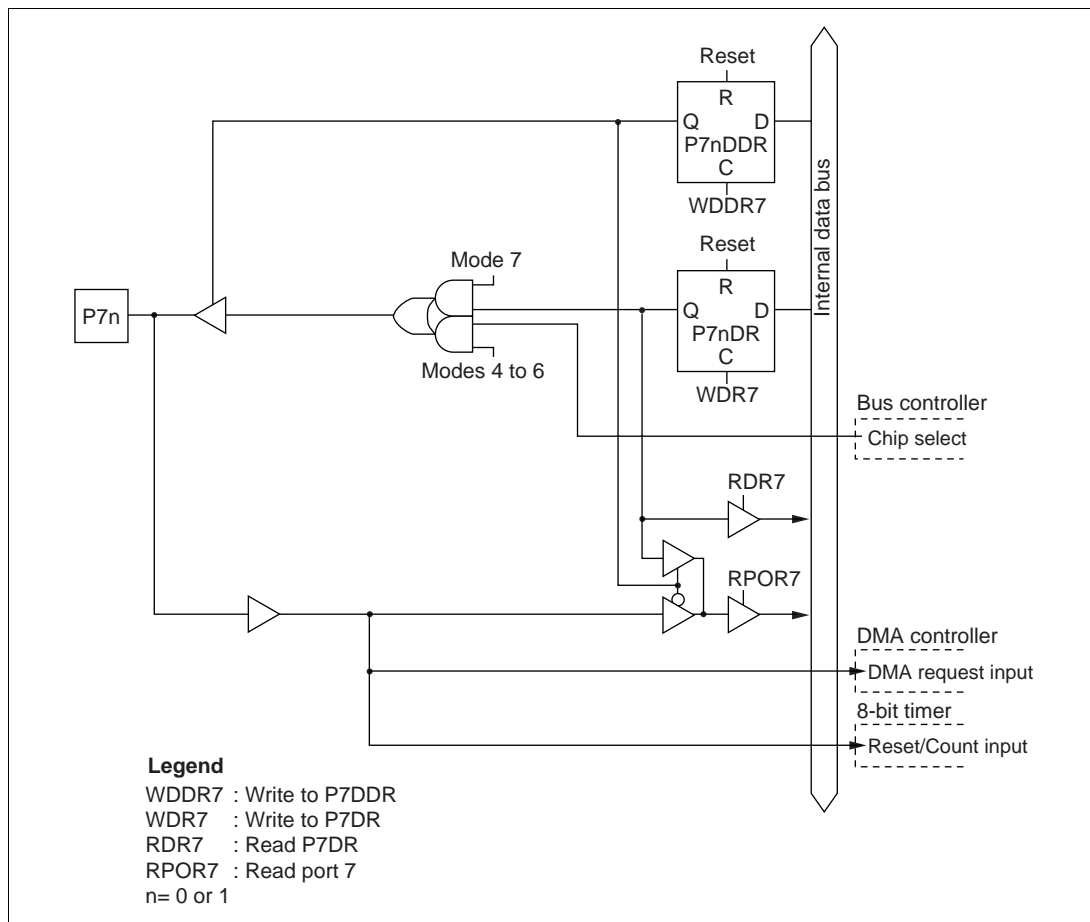
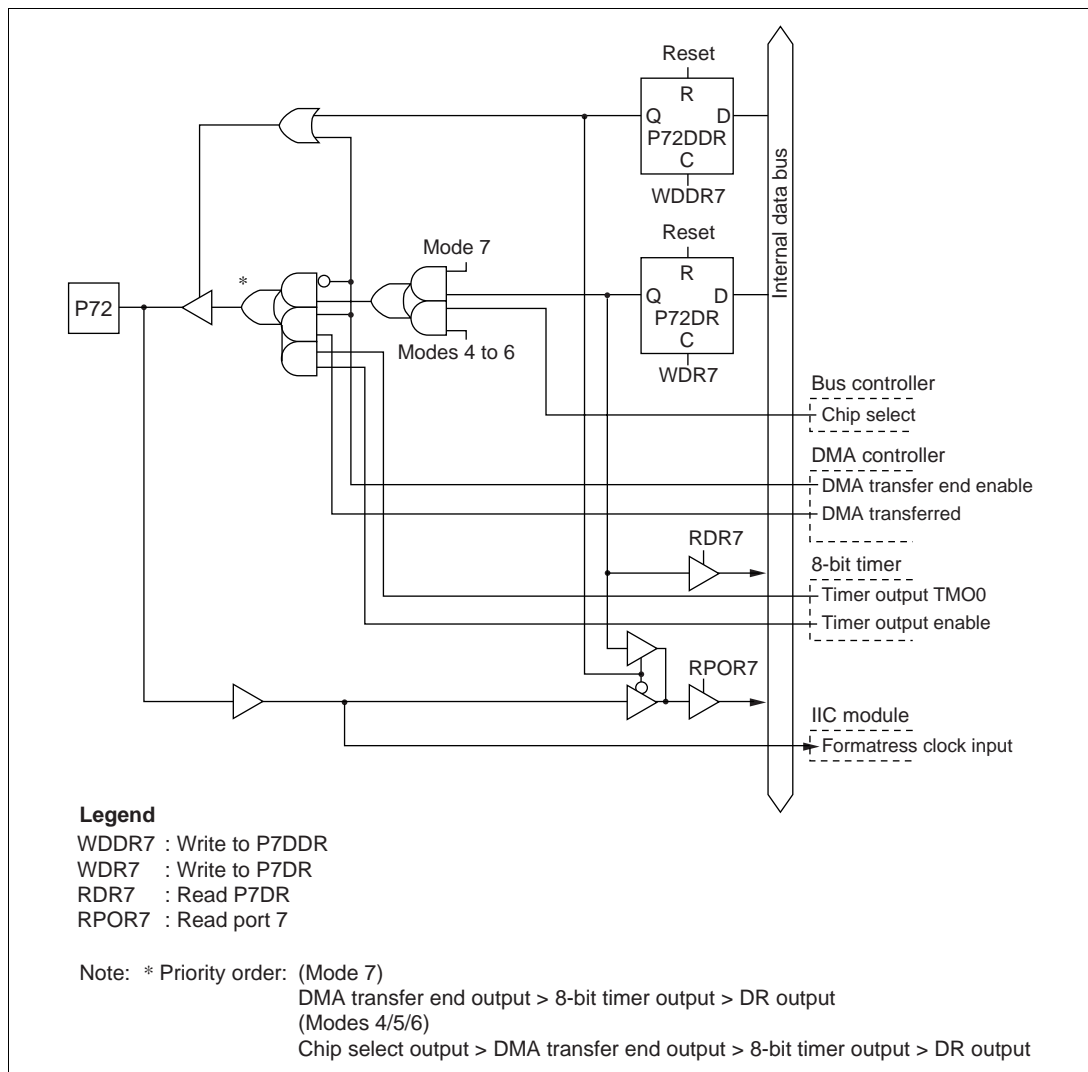
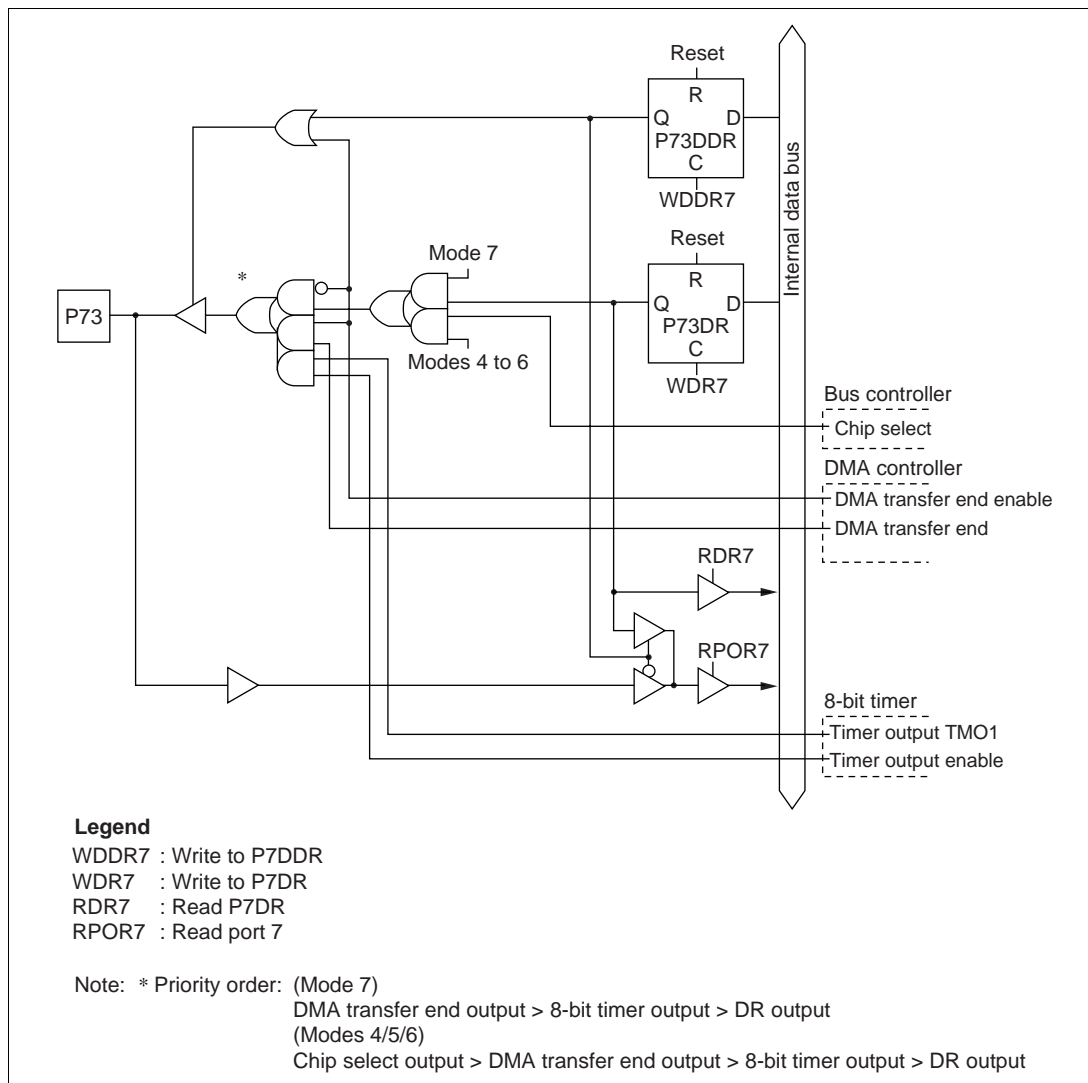


Figure C-4 (a) Port 7 Block Diagram (Pins P70 and P71)

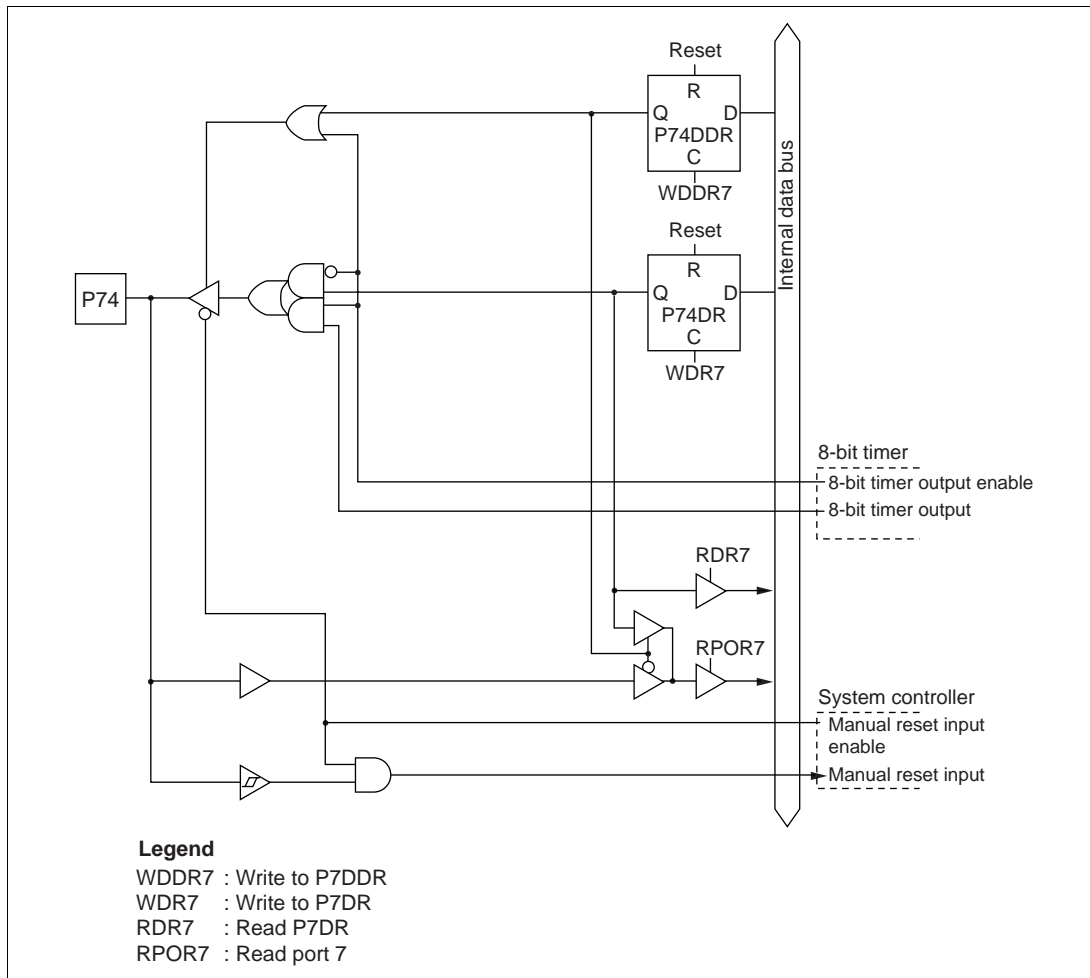




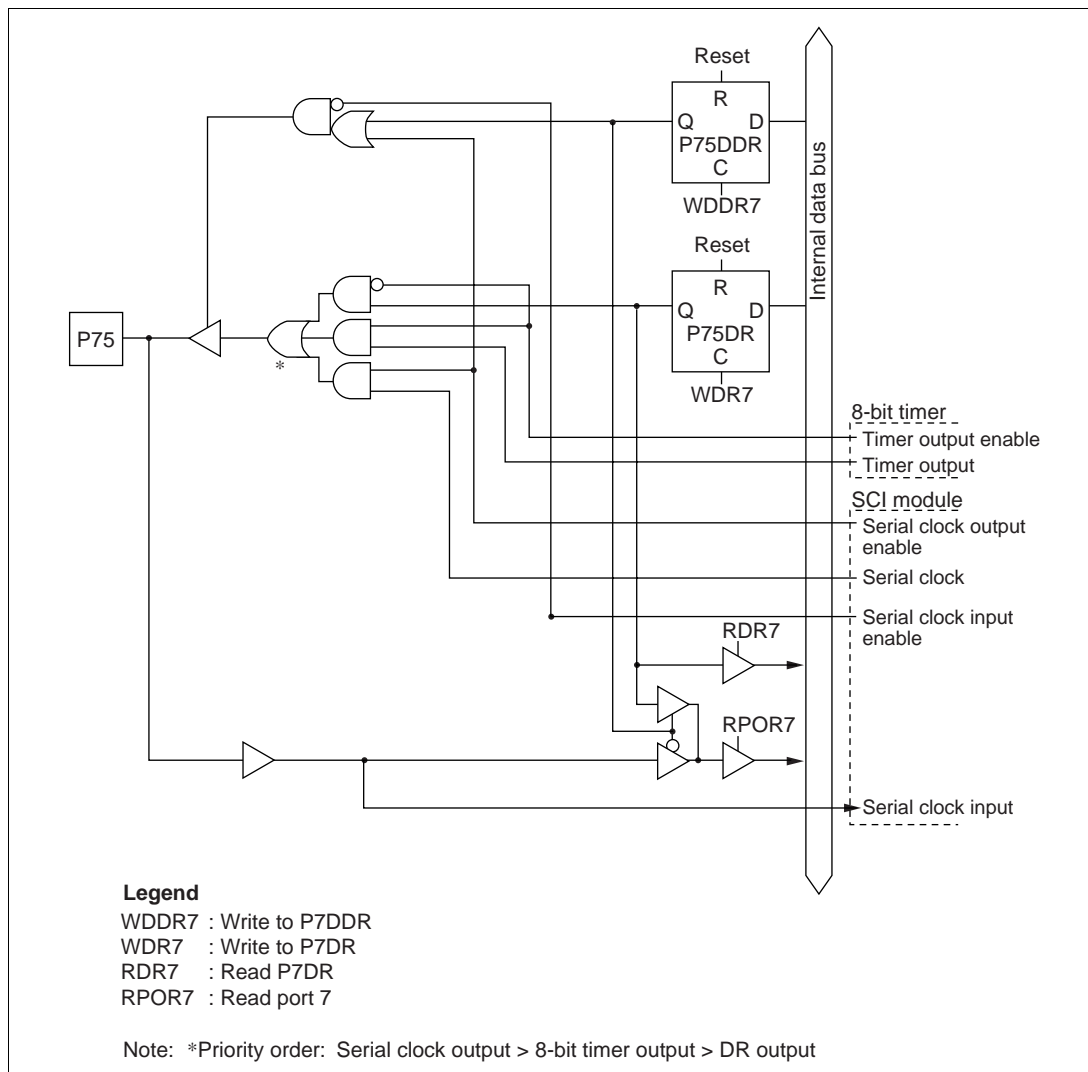
**Figure C-4 (b) Port 7 Block Diagram (Pin P72)**



**Figure C-4 (c) Port 7 Block Diagram (Pin P73)**



**Figure C-4 (d) Port 7 Block Diagram (Pin P74)**



**Figure C-4 (e) Port 7 Block Diagram (Pin P75)**

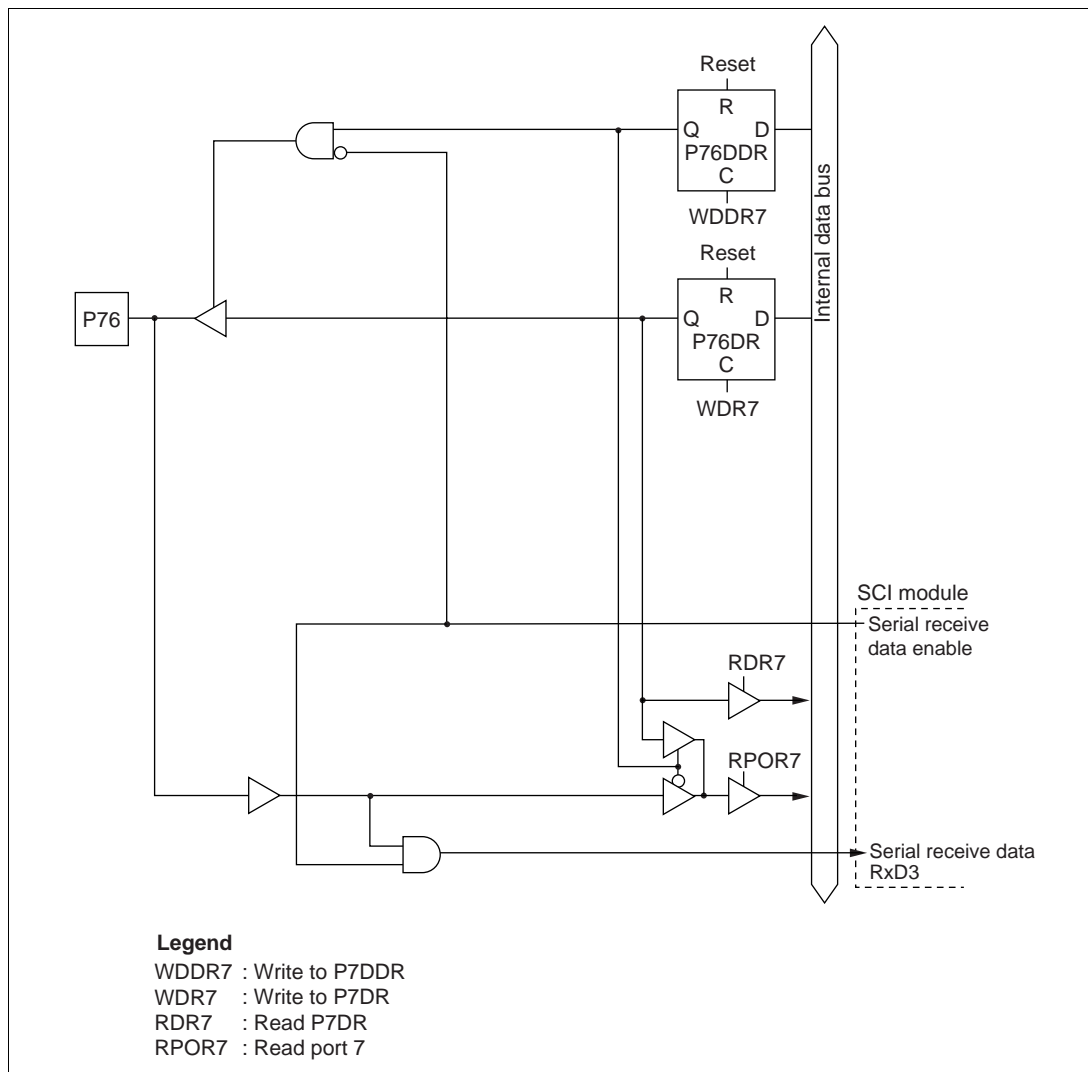


Figure C-4 (f) Port 7 Block Diagram (Pin P76)

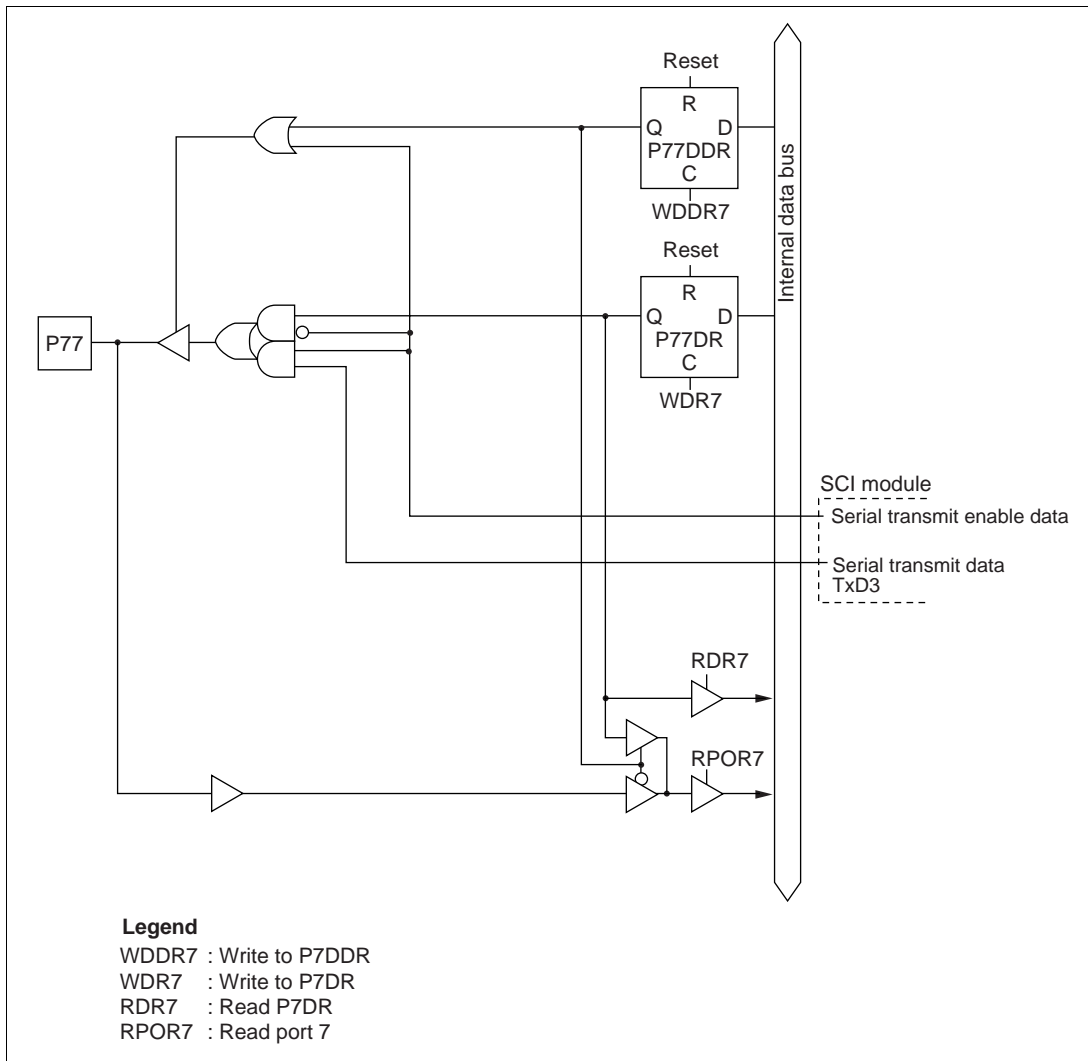


Figure C-4 (g) Port 7 Block Diagram (Pin P77)

## C.5 Port 9 Block Diagram

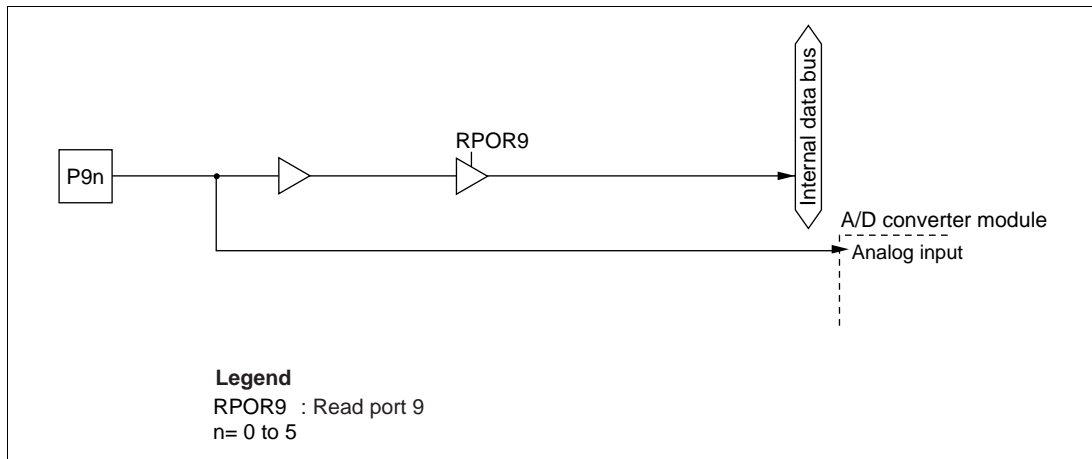


Figure C-5 (a) Port 9 Block Diagram (Pins P90 to P95)

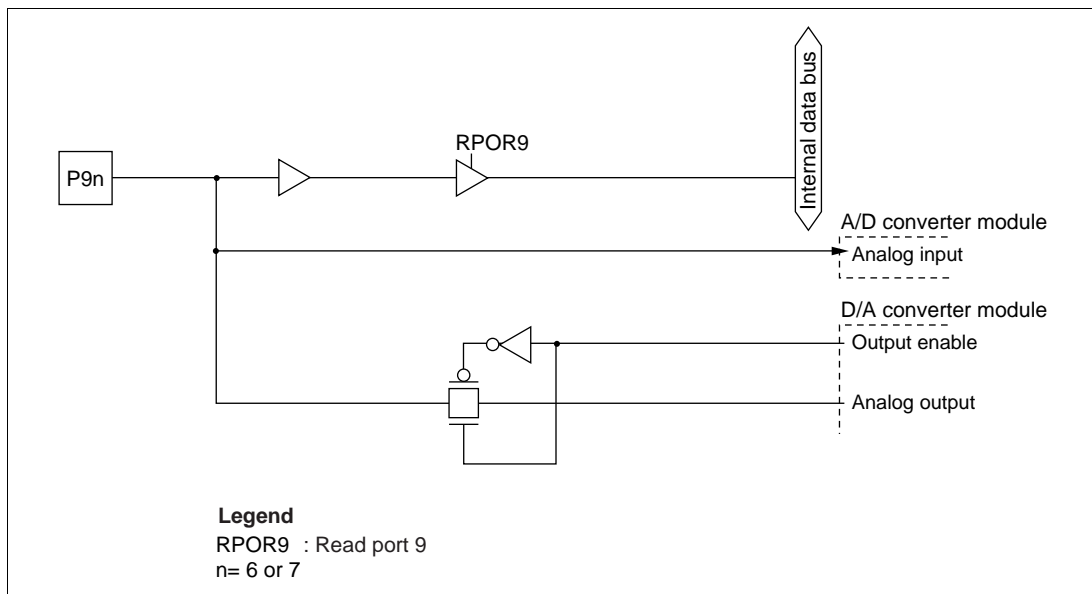


Figure C-5 (b) Port 9 Block Diagram (Pins P96 and P97)

## C.6 Port A Block Diagram

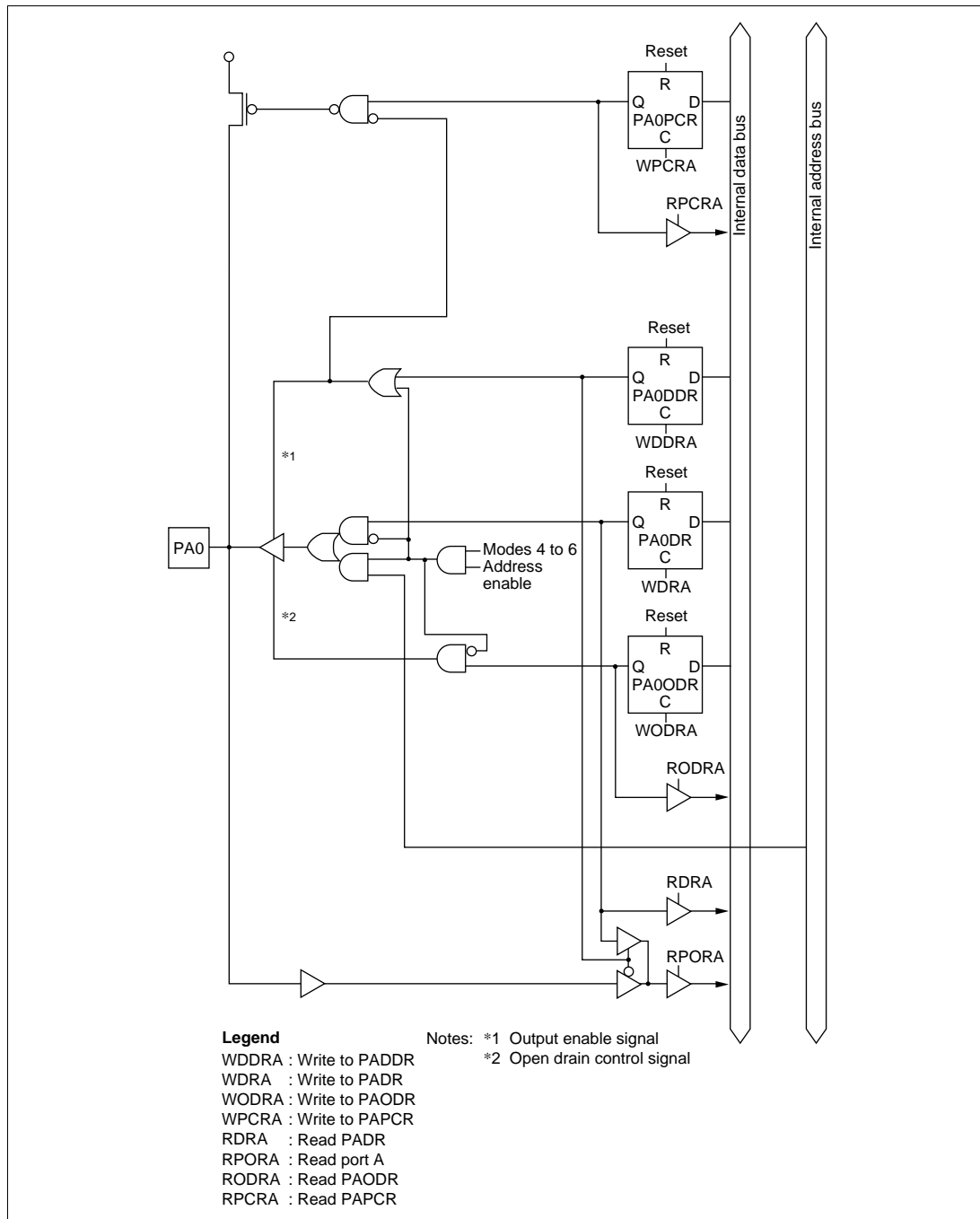


Figure C-6 (a) Port A Block Diagram (Pin PA0)



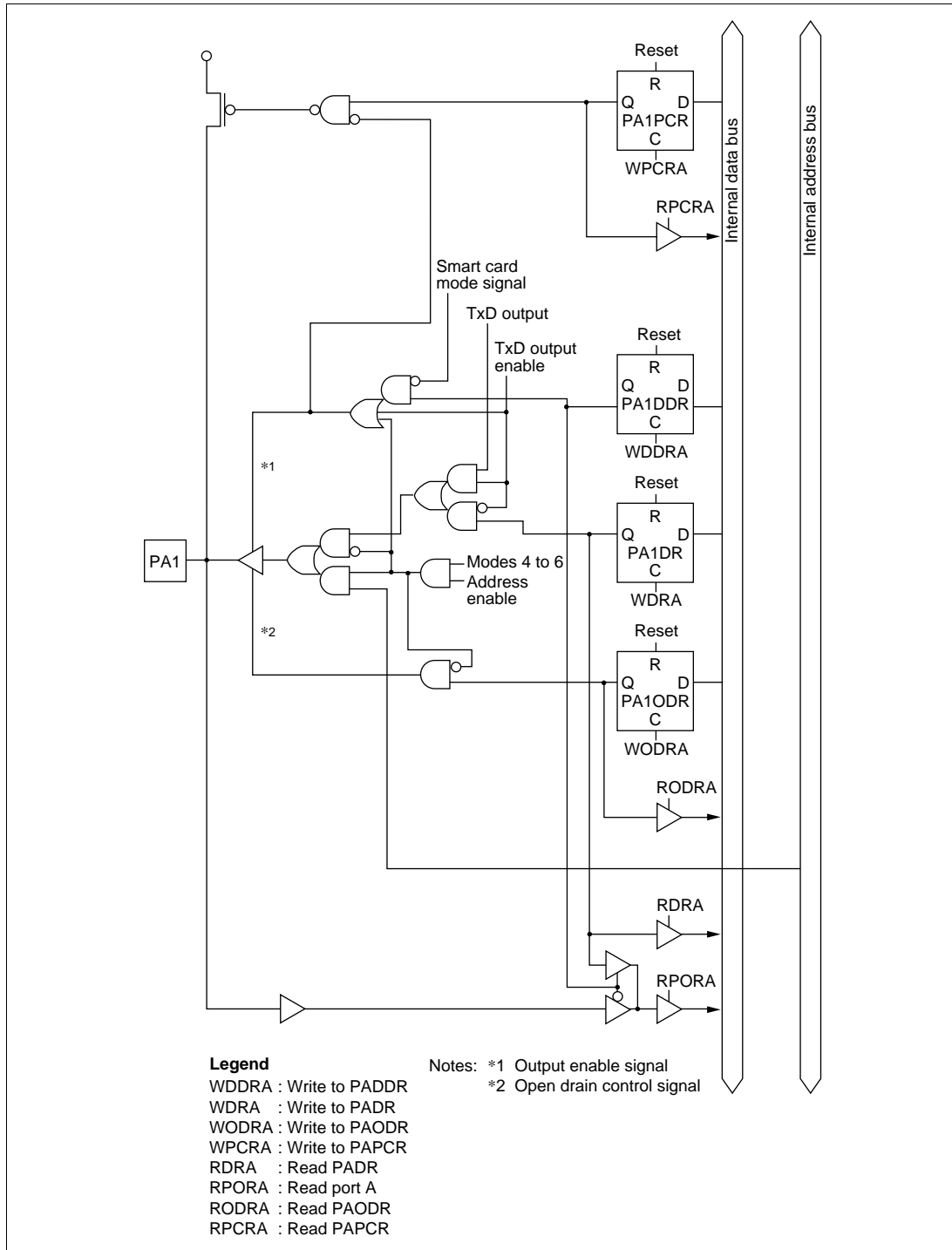


Figure C-6 (b) Port A Block Diagram (Pin PA1)

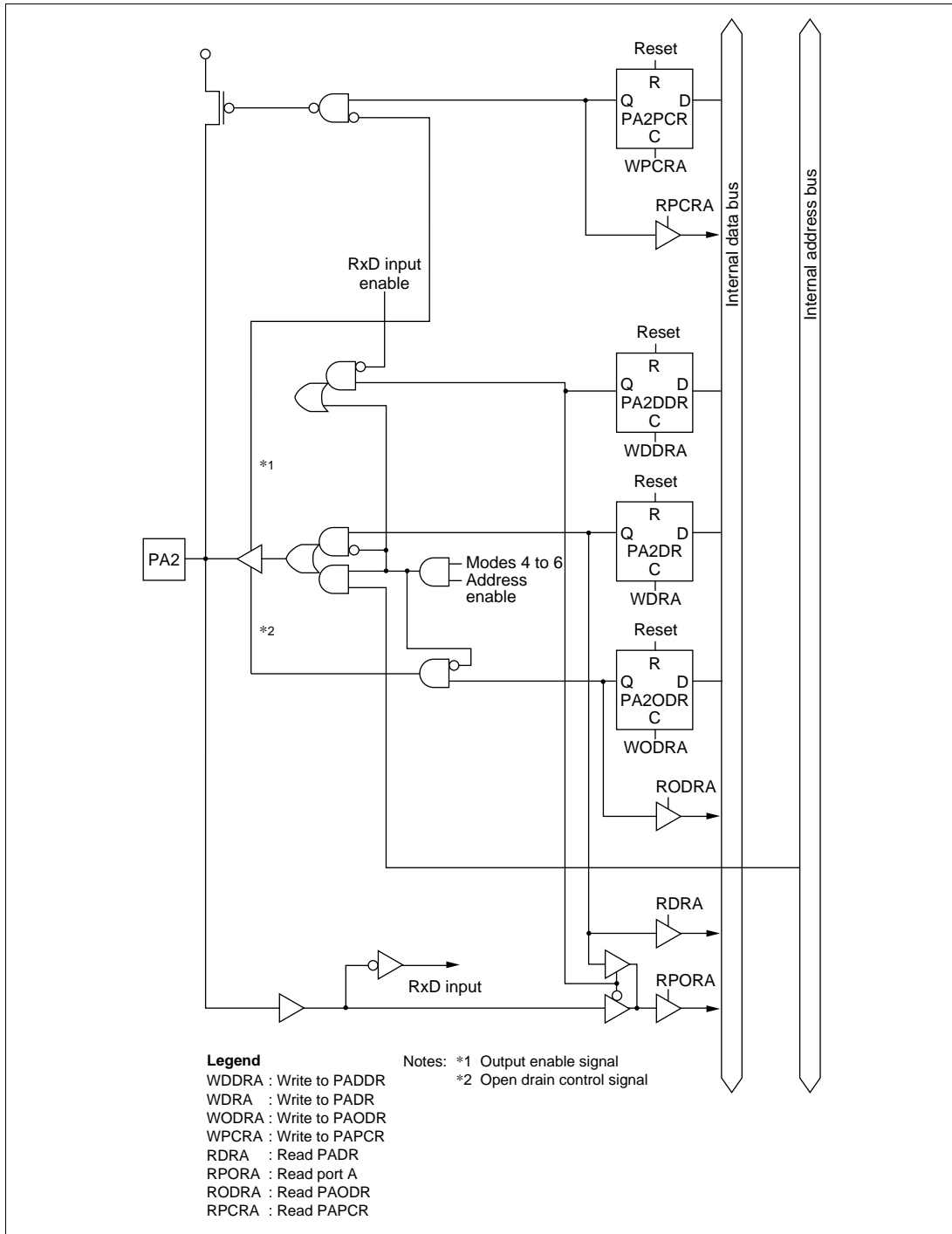


Figure C-6 (c) Port A Block Diagram (Pin PA2)

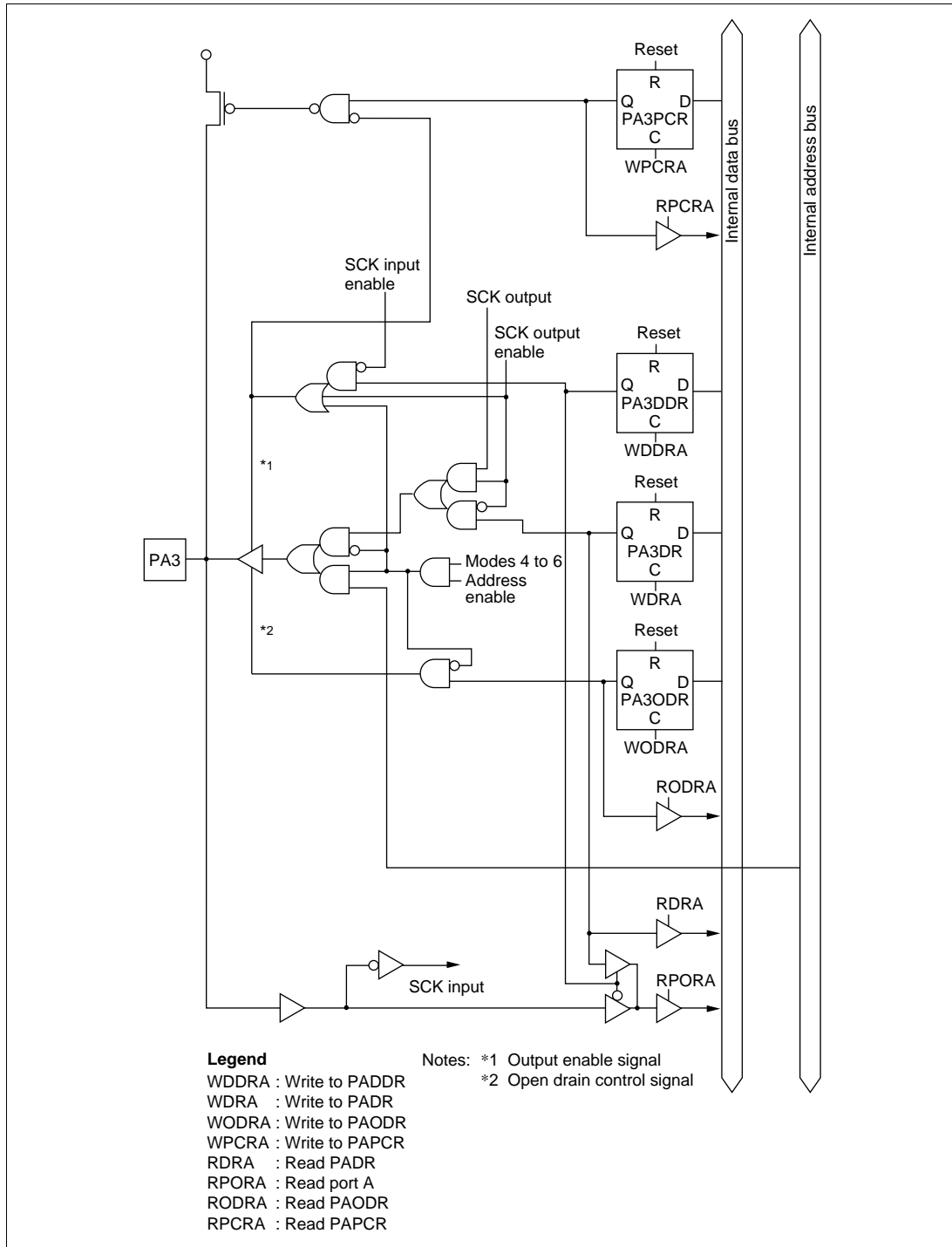


Figure C-6 (d) Port A Block Diagram (Pin PA3)

## C.7 Port B Block Diagram

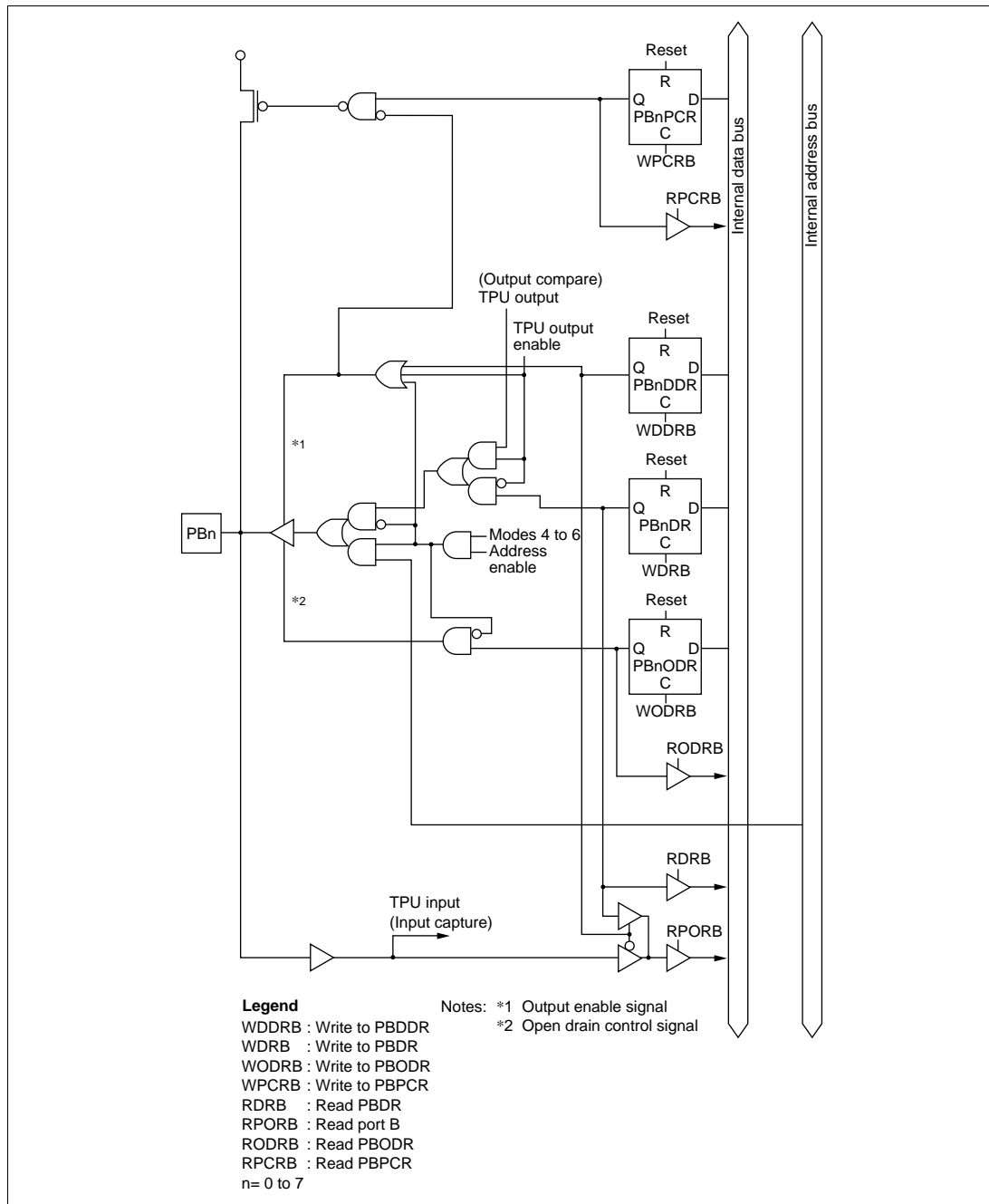


Figure C-7 Port B Block Diagram (Pins PB0 to PB7)

## C.8 Port C Block Diagram

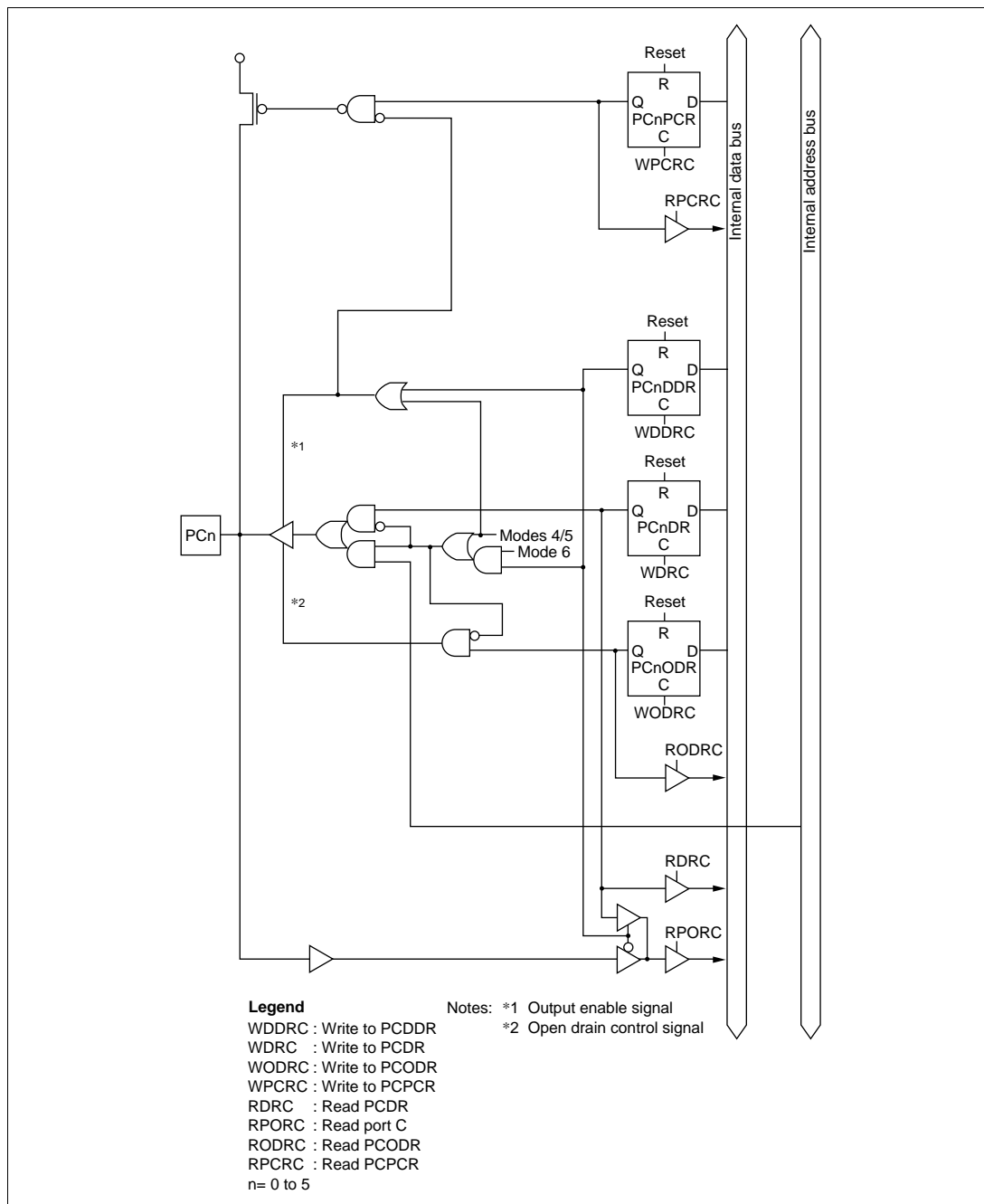
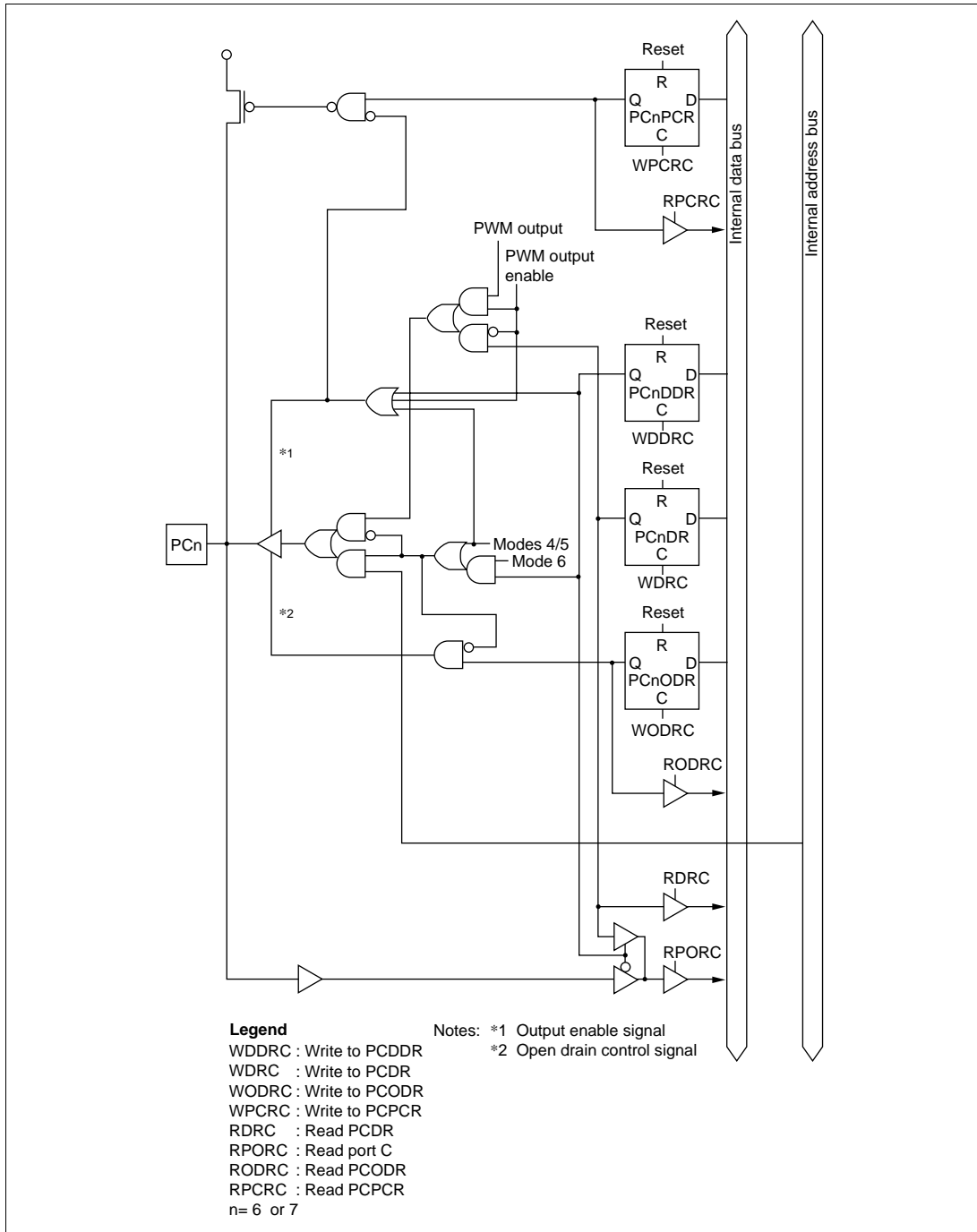


Figure C-8 (a) Port C Block Diagram (Pins PC0 to PC5)



**Figure C-8 (b) Port C Block Diagram (Pins PC6 and PC7)**

## C.9 Port D Block Diagram

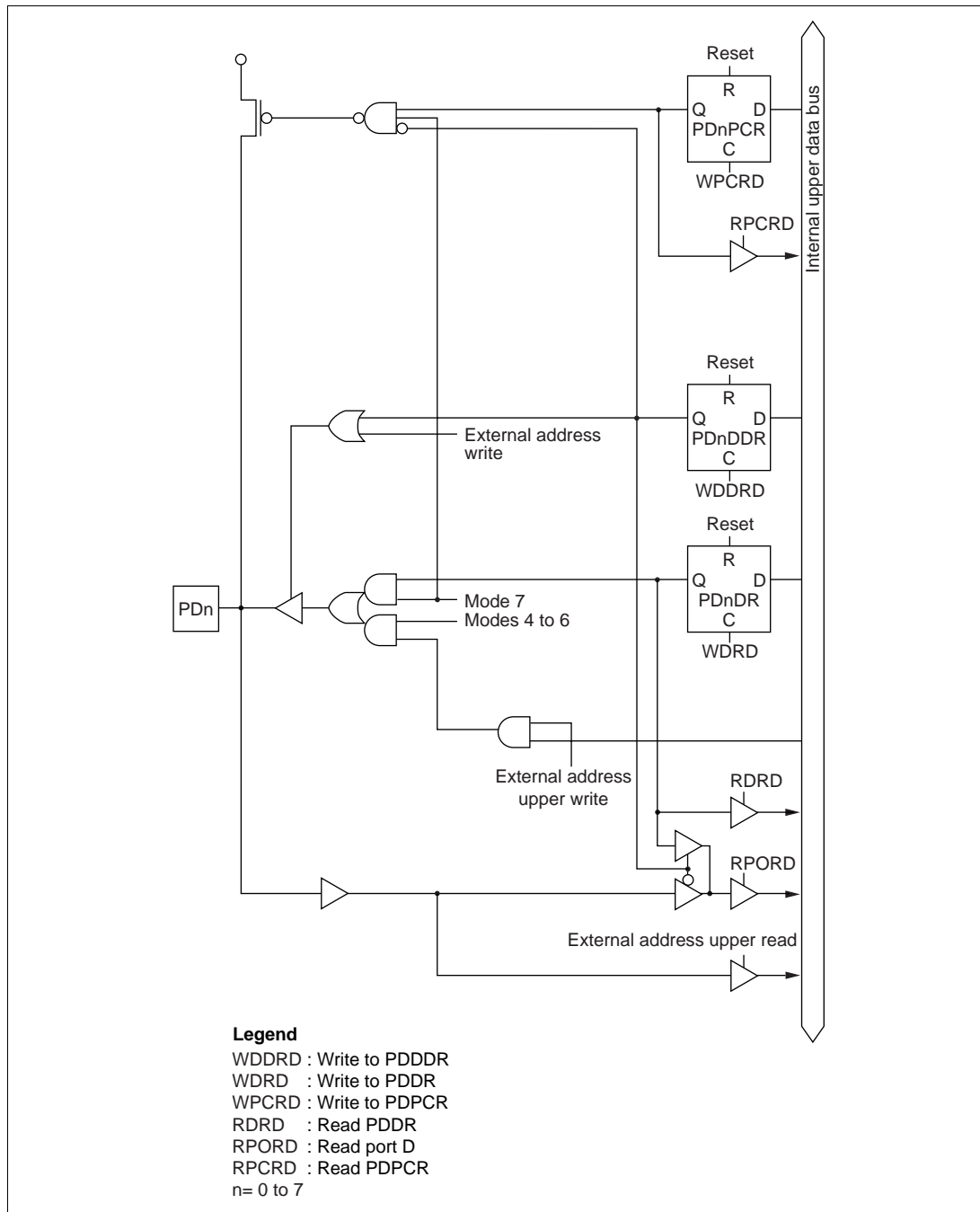


Figure C-9 Port D Block Diagram (Pins PD0 to PD7)

## C.10 Port E Block Diagram

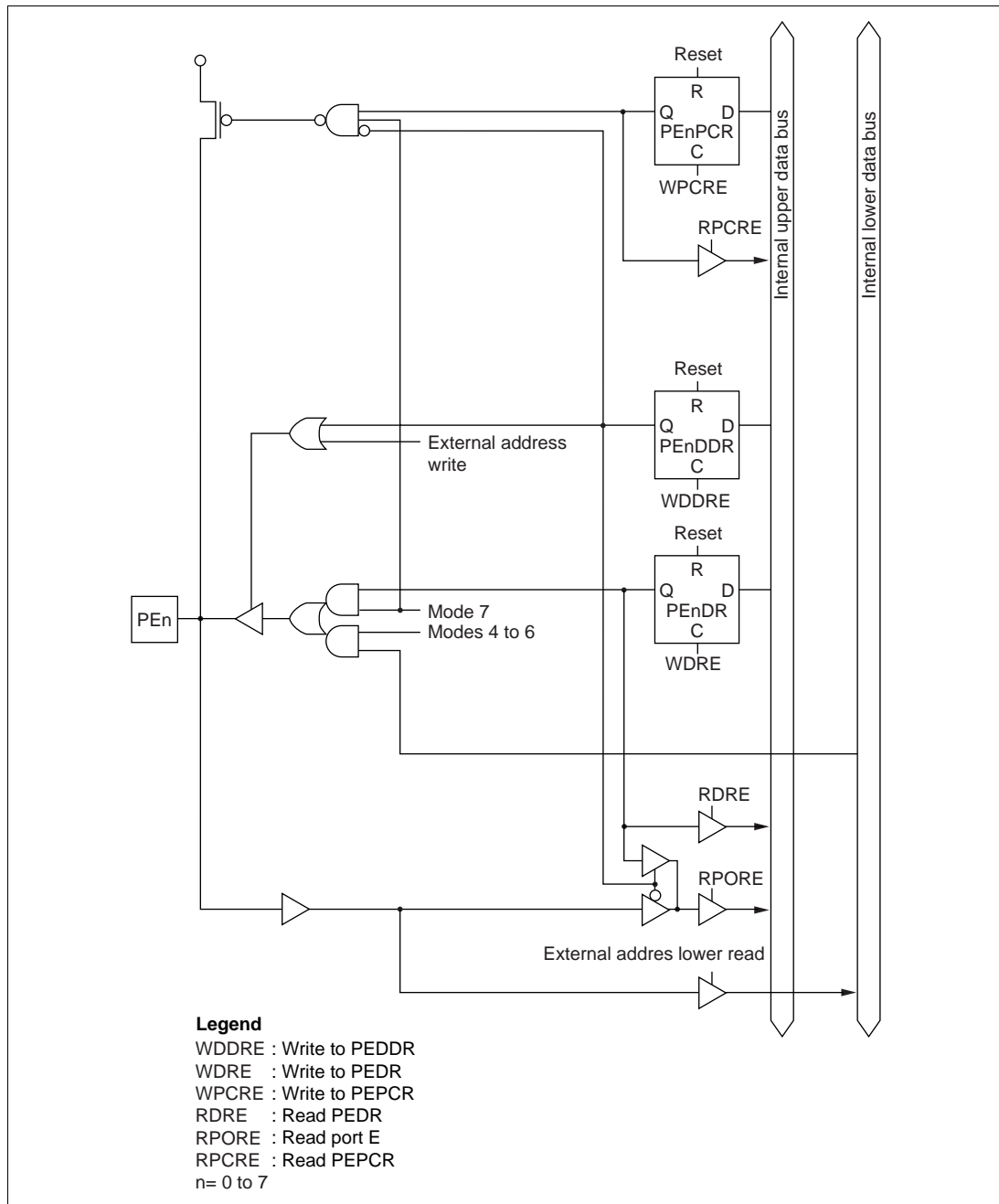


Figure C-10 Port E Block Diagram (Pins PE0 to PE7)



### C.11 Port F Block Diagram

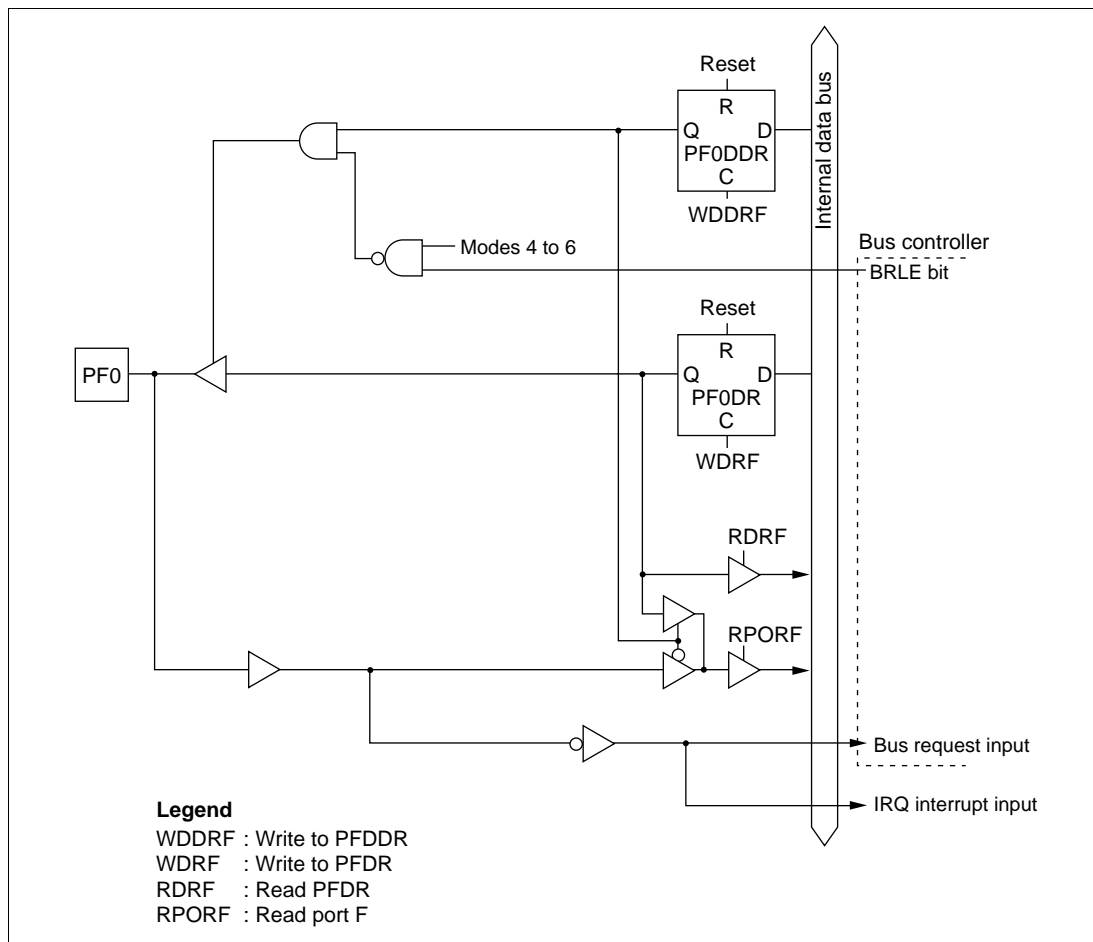


Figure C-11 (a) Port F Block Diagram (Pin PF0)

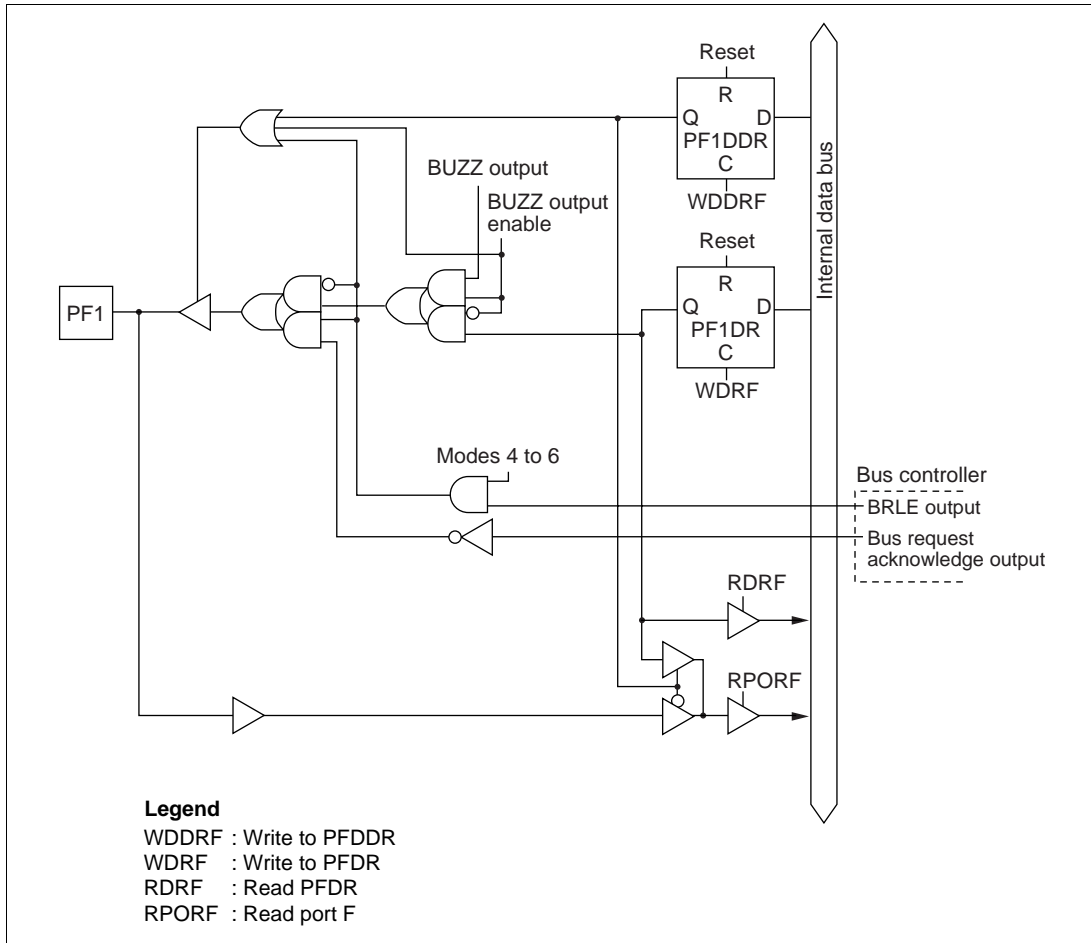


Figure C-11 (b) Port F Block Diagram (Pin PF1)

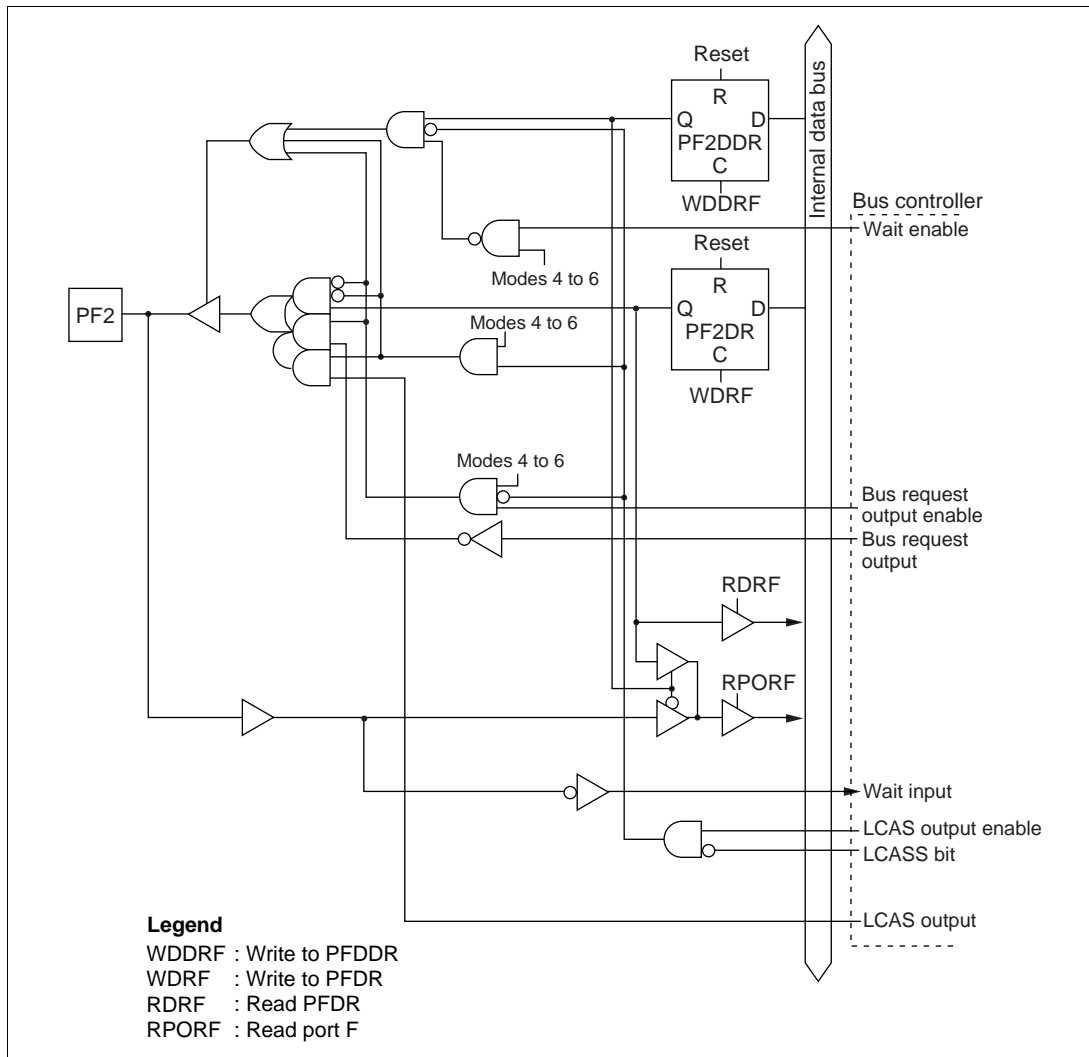


Figure C-11 (c) Port F Block Diagram (Pin PF2)

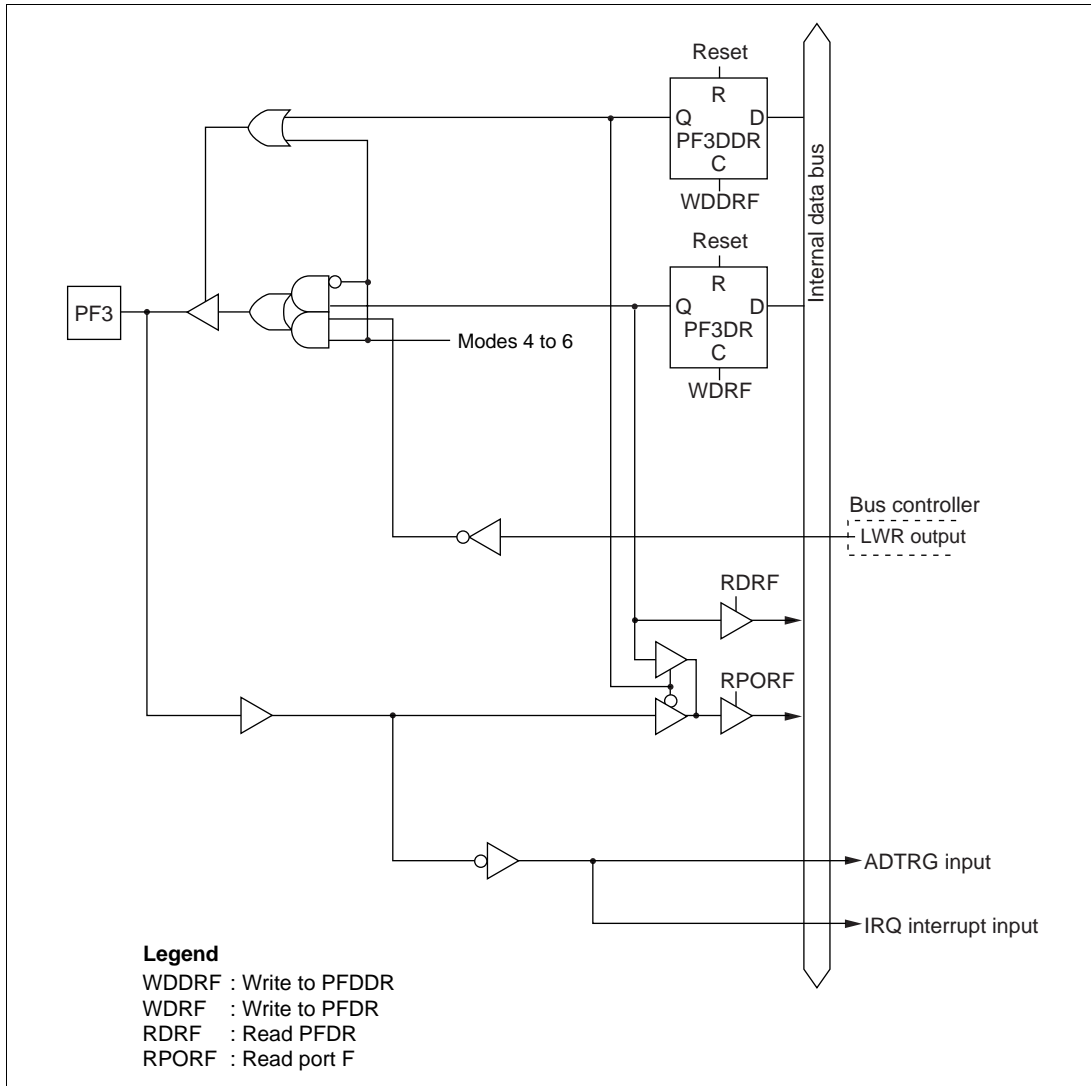


Figure C-11 (d) Port F Block Diagram (Pin PF3)

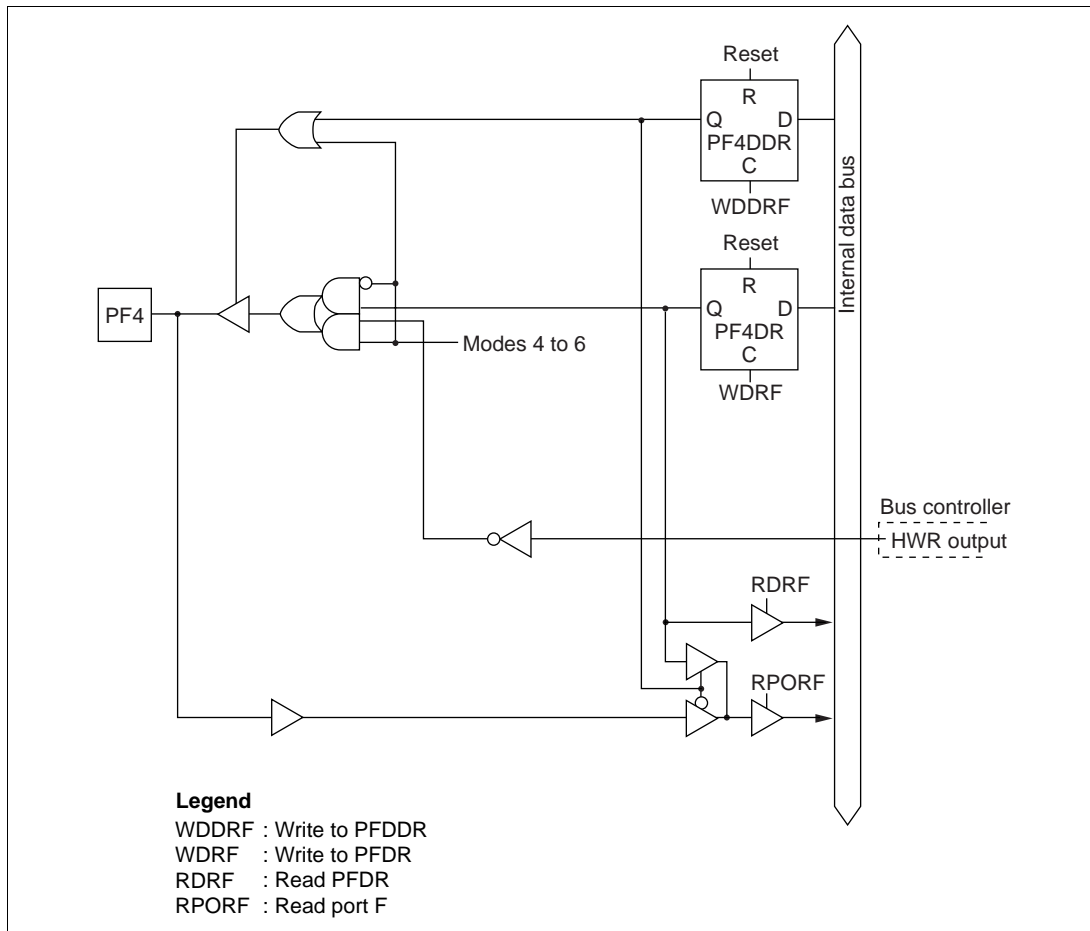


Figure C-11 (e) Port F Block Diagram (Pin PF4)

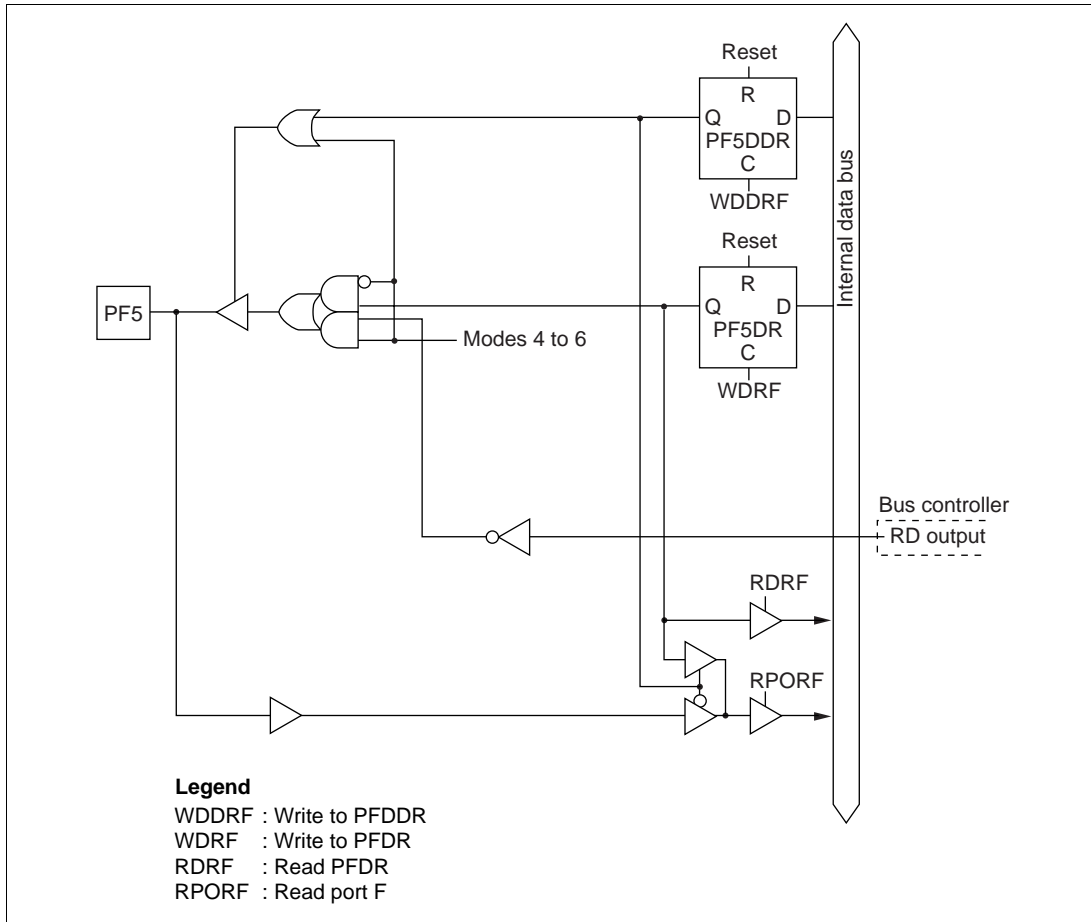
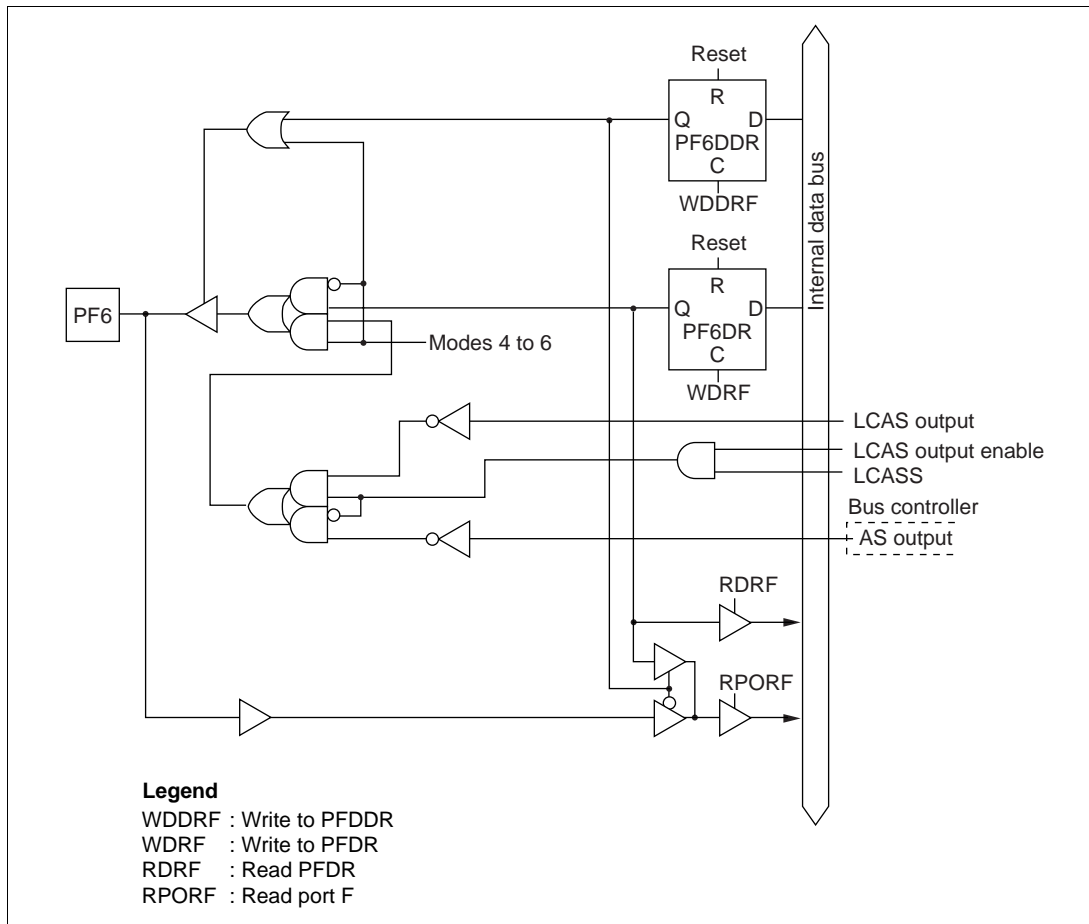
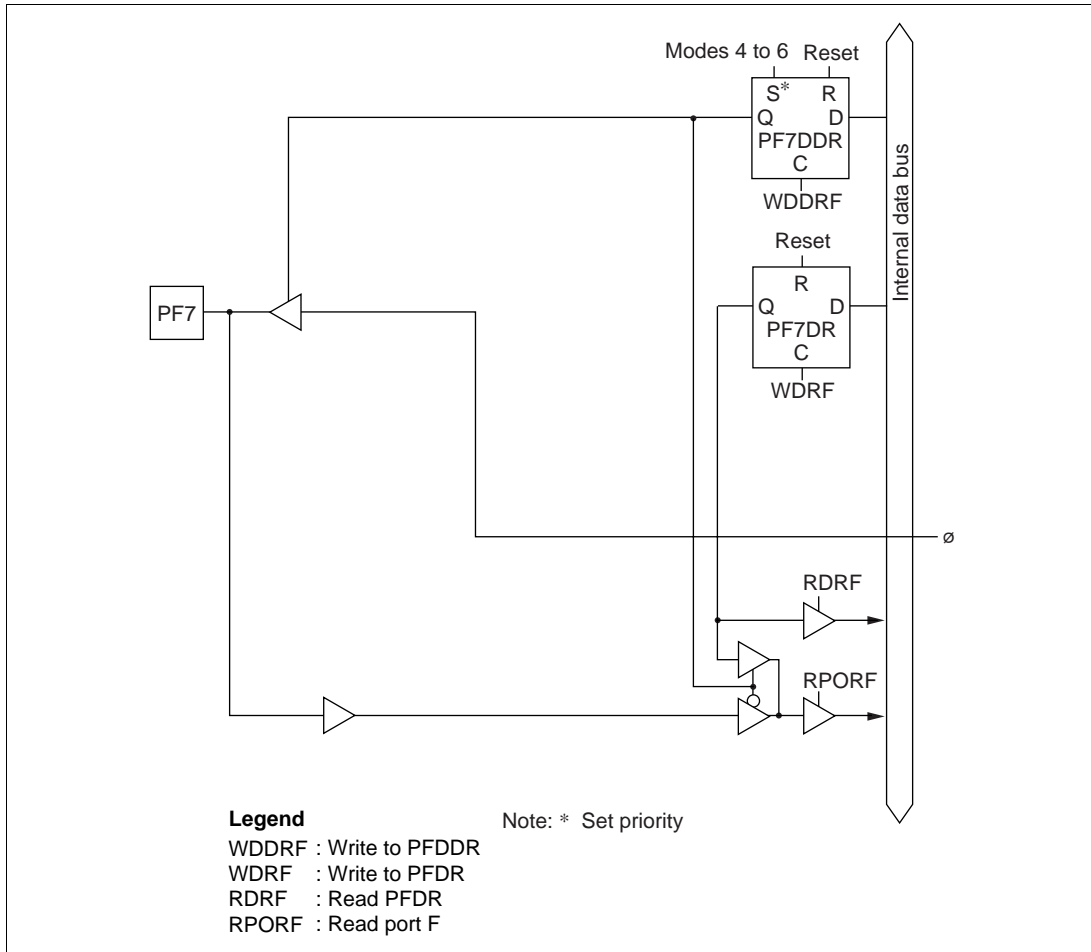


Figure C-11 (f) Port F Block Diagram (Pin PF5)



**Figure C-11 (g) Port F Block Diagram (Pin PF6)**



**Figure C-11 (h) Port F Block Diagram (Pin PF7)**



## C.12 Port G Block Diagram

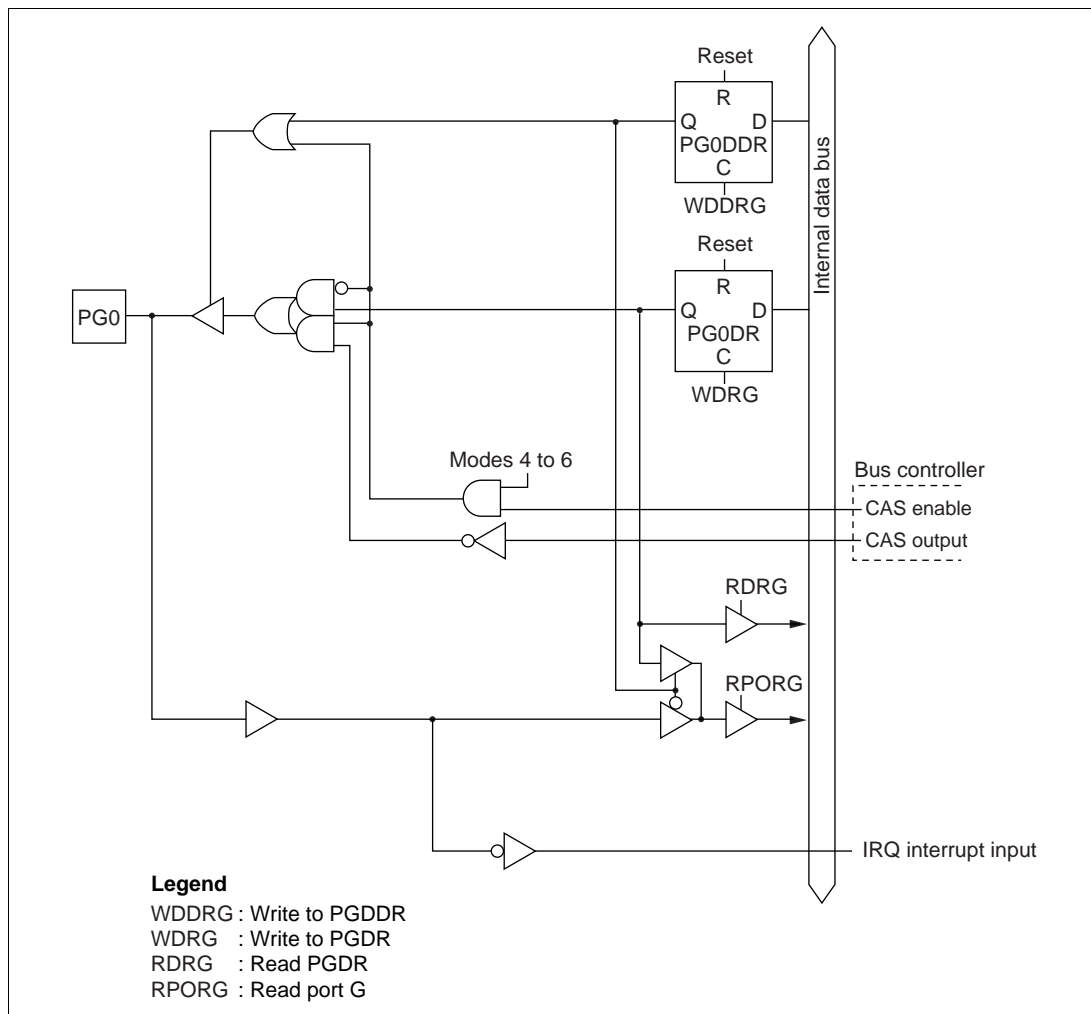


Figure C-12 (a) Port G Block Diagram (Pin PG0)

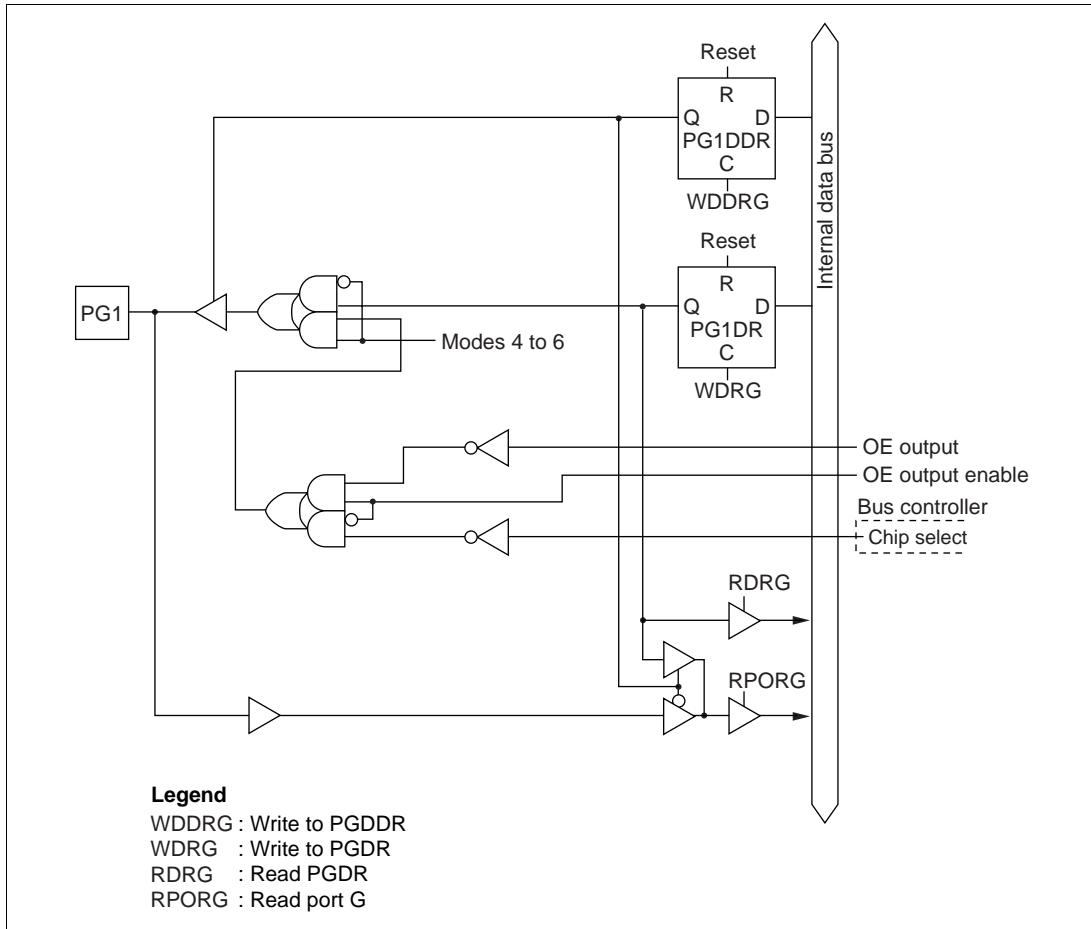


Figure C-12 (b) Port G Block Diagram (Pin PG1)

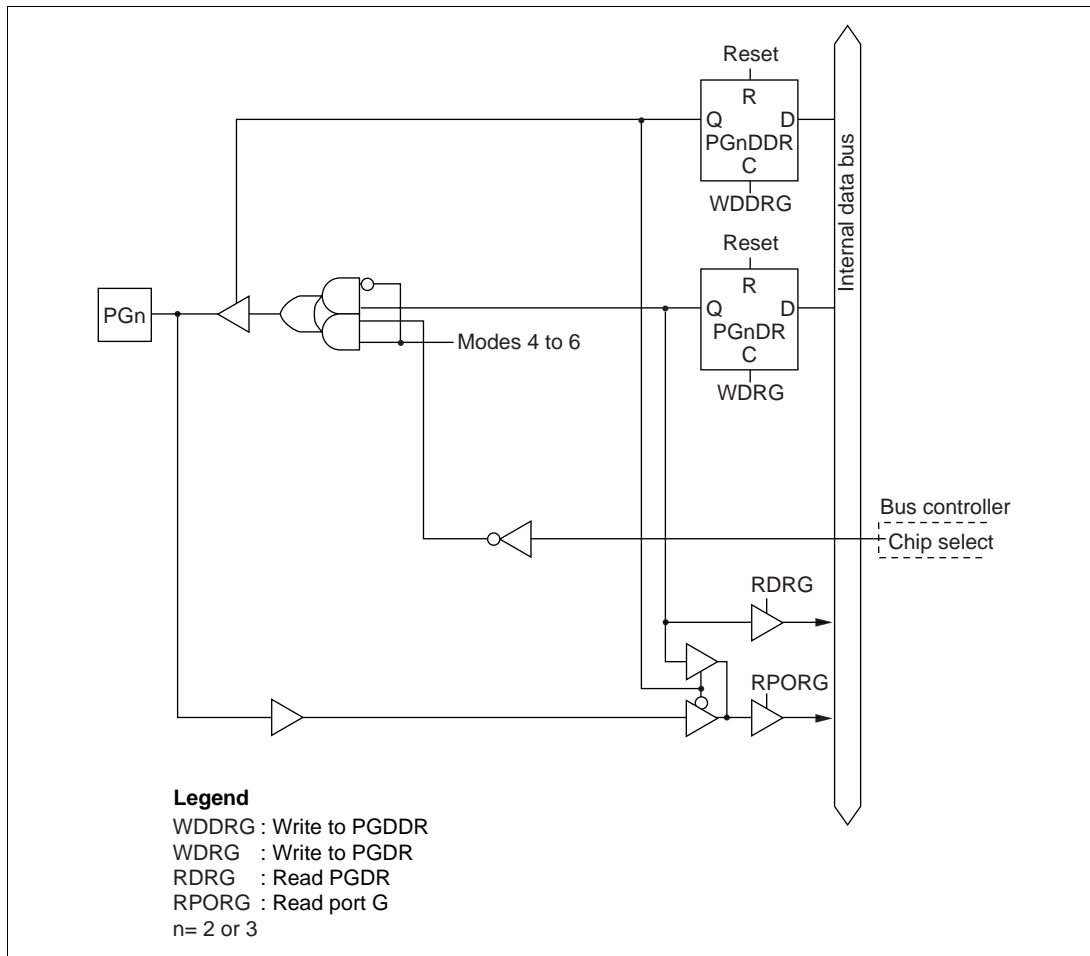
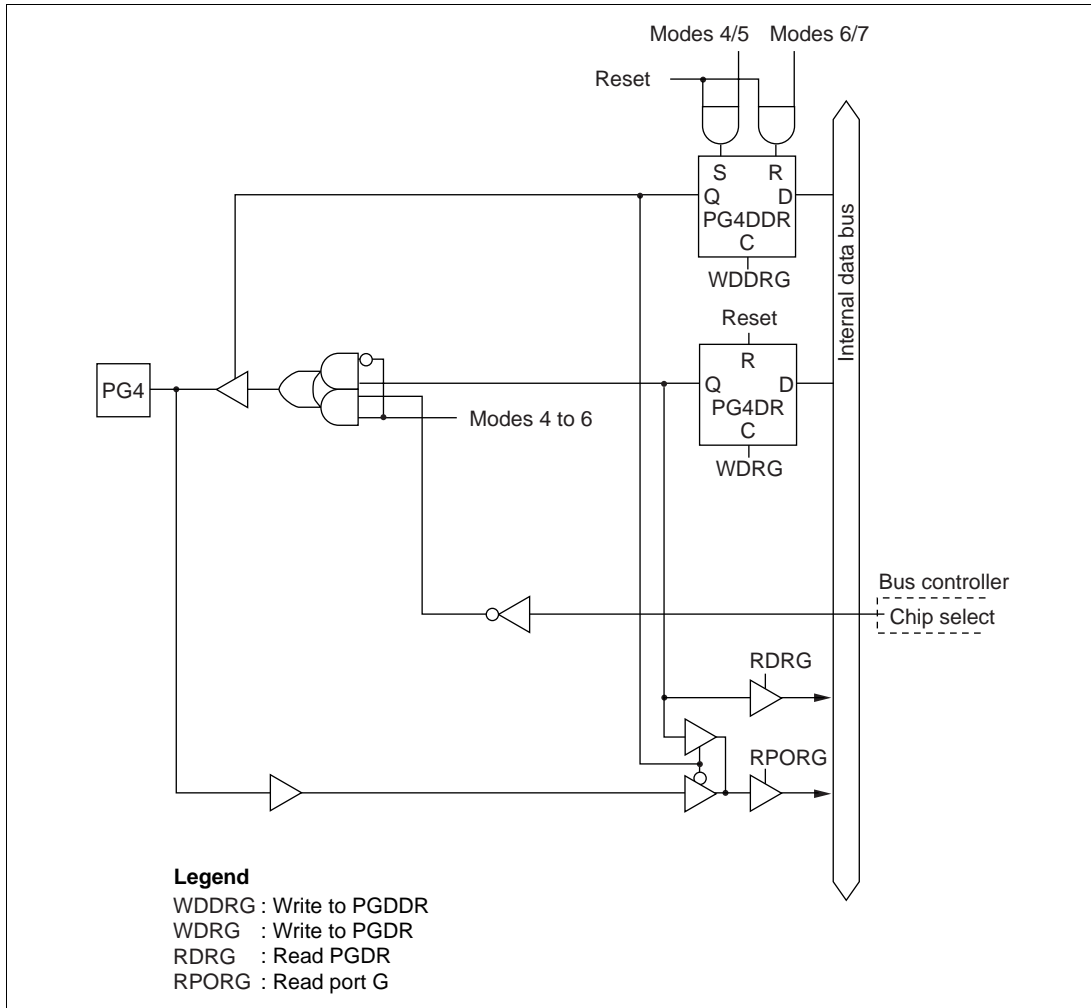
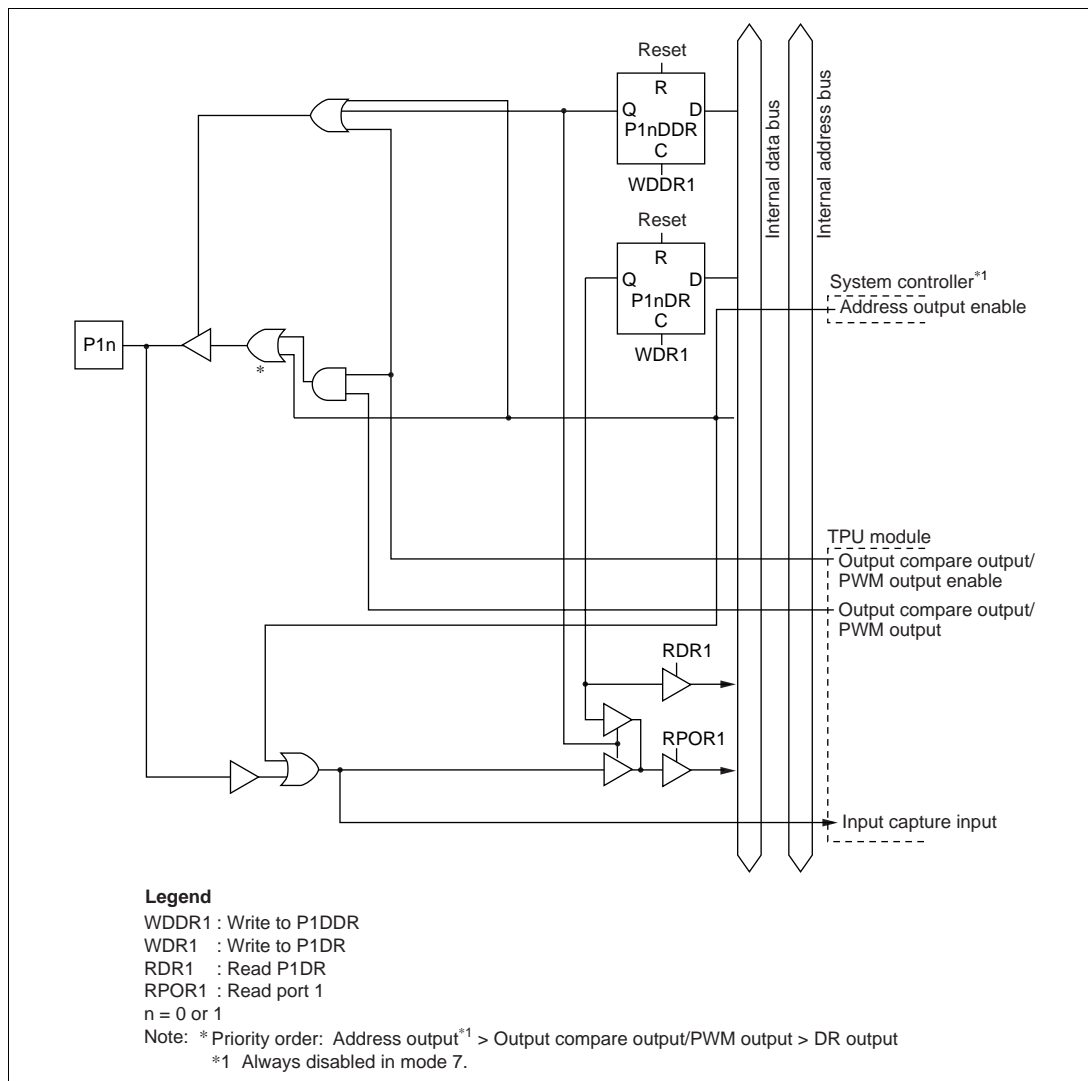


Figure C-12 (c) Port G Block Diagram (Pin PG2 and PG3)

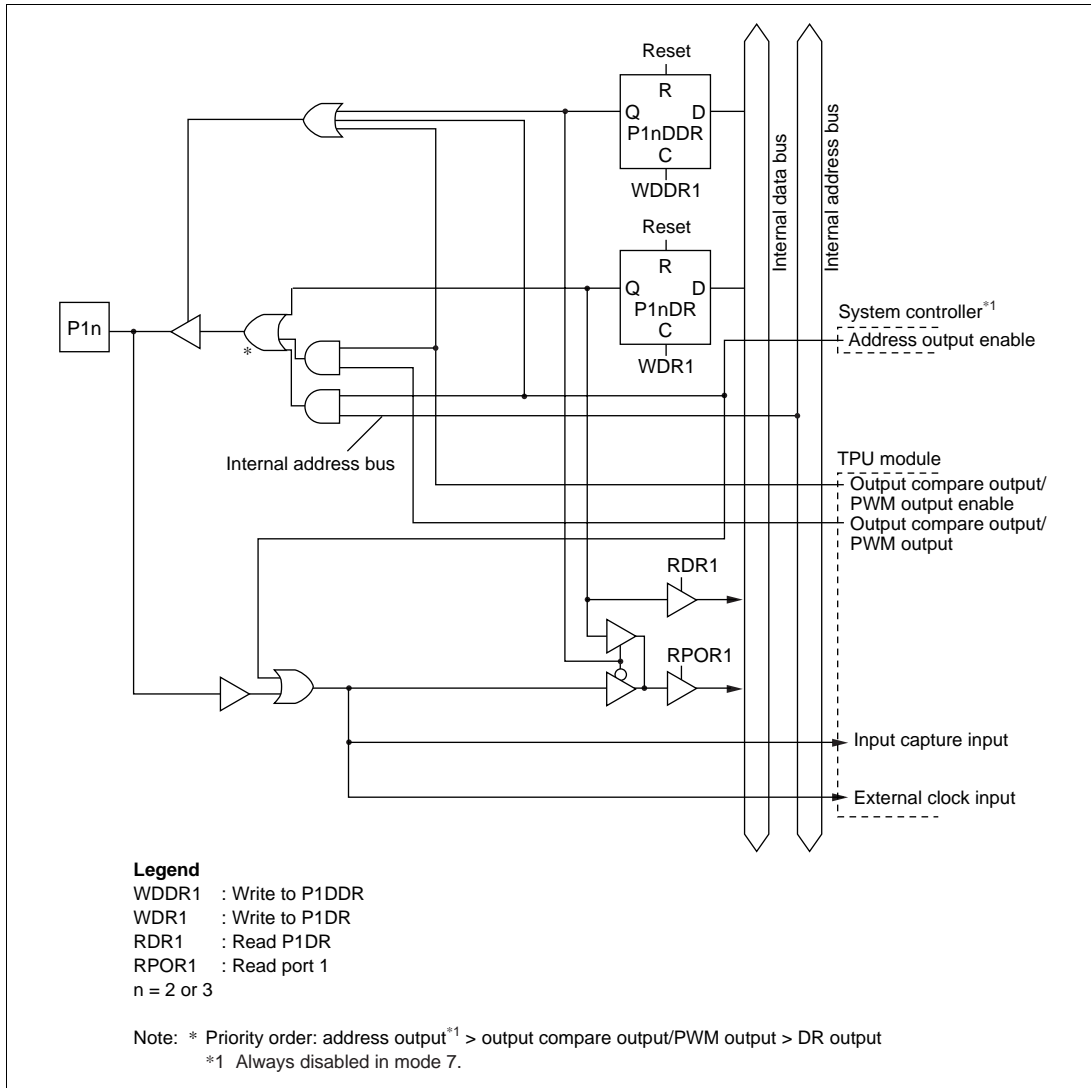


**Figure C-12 (d) Port G Block Diagram (Pin PG4)**

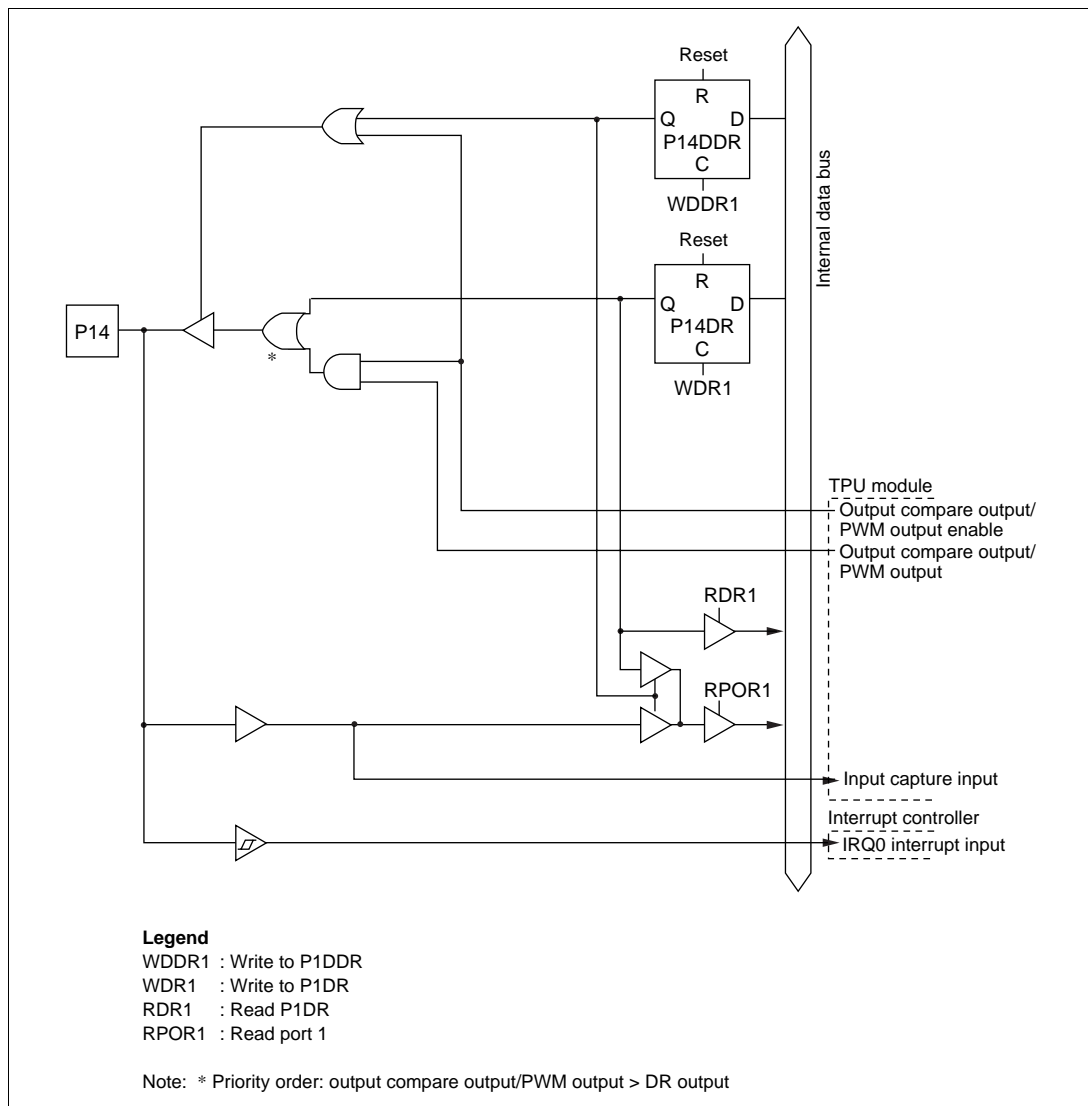
### C.13 Port 1 Block Diagram



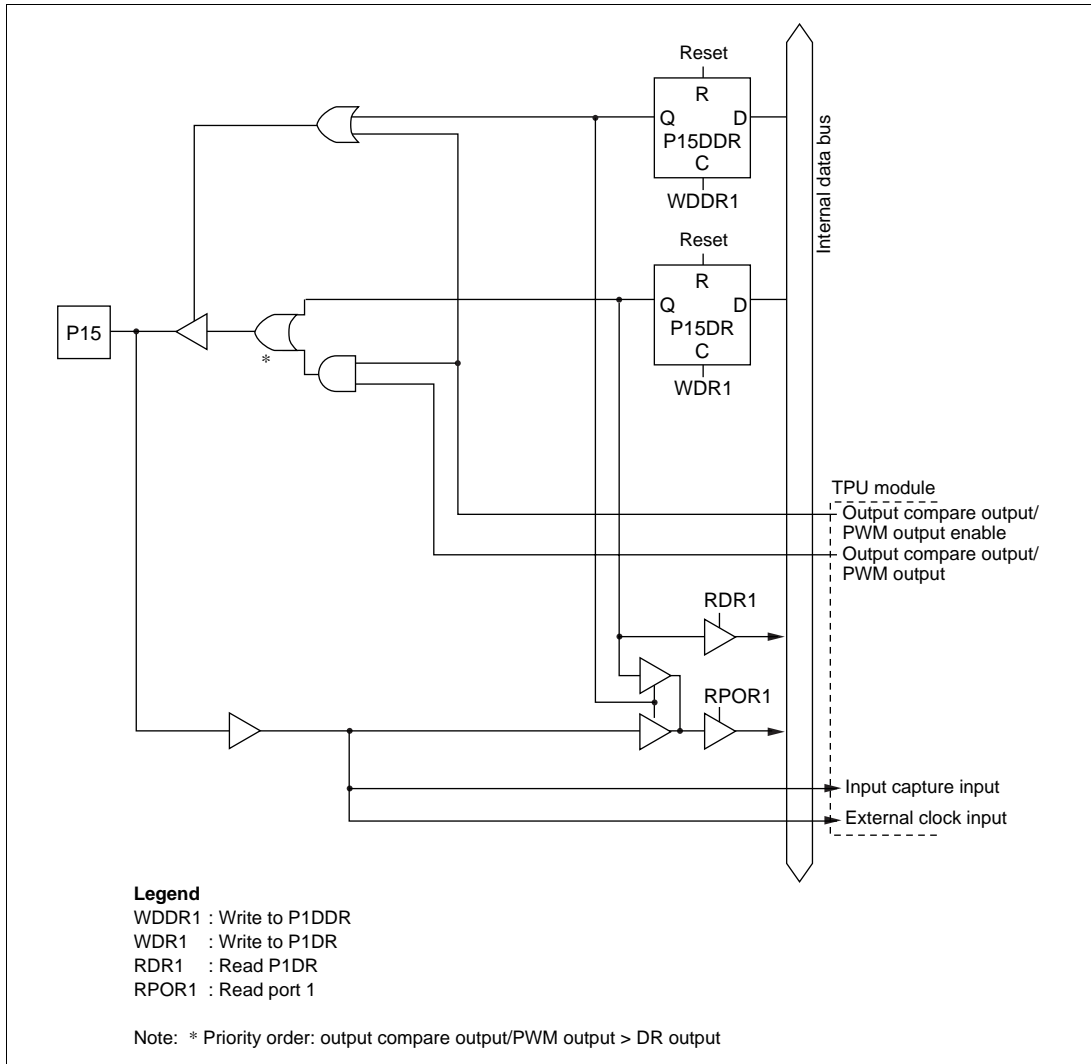
**Figure C-13 (a) Port 1 Block Diagram (Pins P10 and P11)**



**Figure C-13 (b) Port 1 Block Diagram (Pins P12 and P13)**

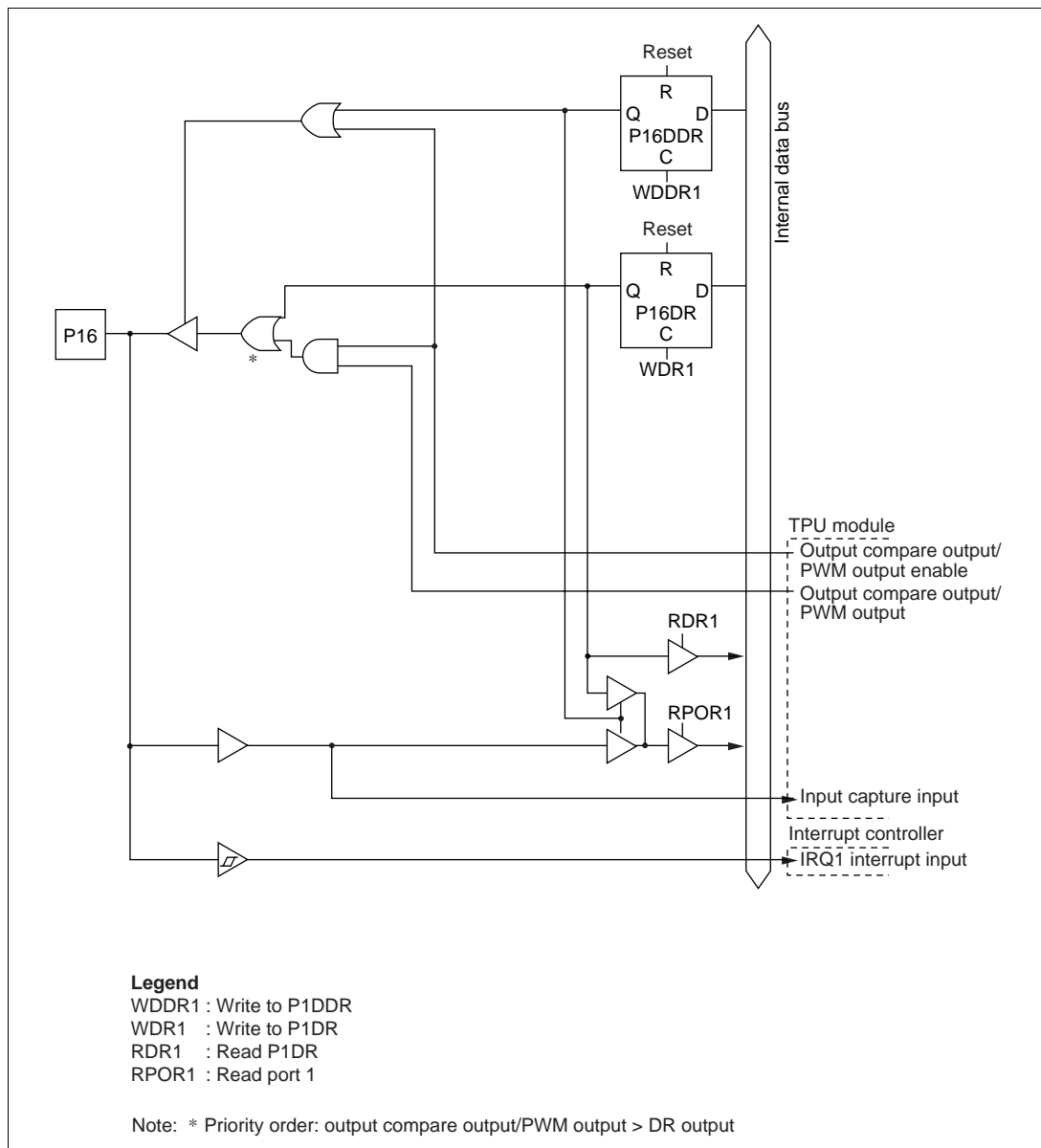


**Figure C-13 (c) Port 1 Block Diagram (Pin P14)**



**Figure C-13 (d) Port 1 Block Diagram (Pin P15)**





**Figure C-13 (e) Port 1 Block Diagram (Pin P16)**

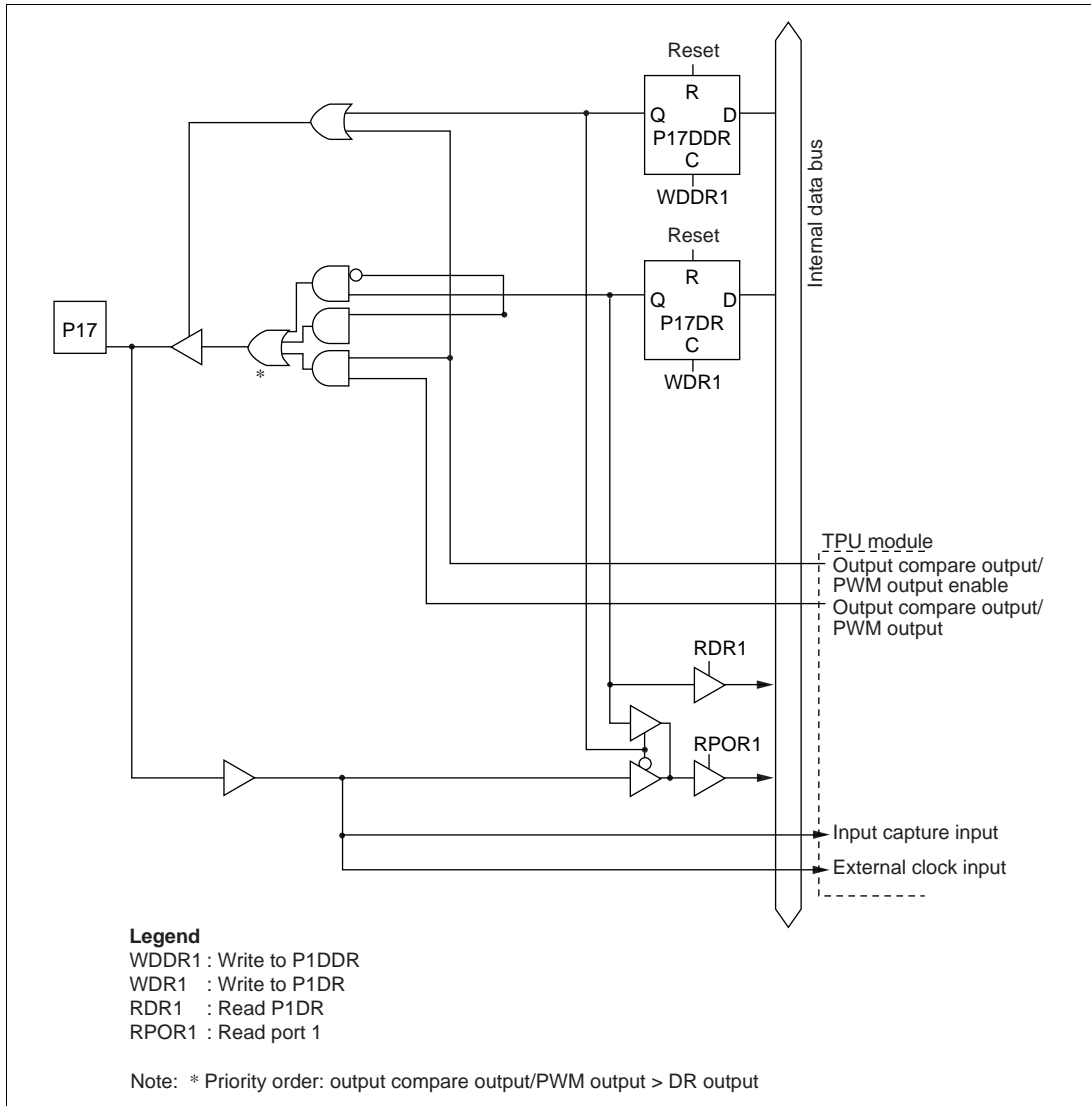


Figure C-13 (f) Port 1 Block Diagram (Pin P17)

## C.14 Port 3 Block Diagram

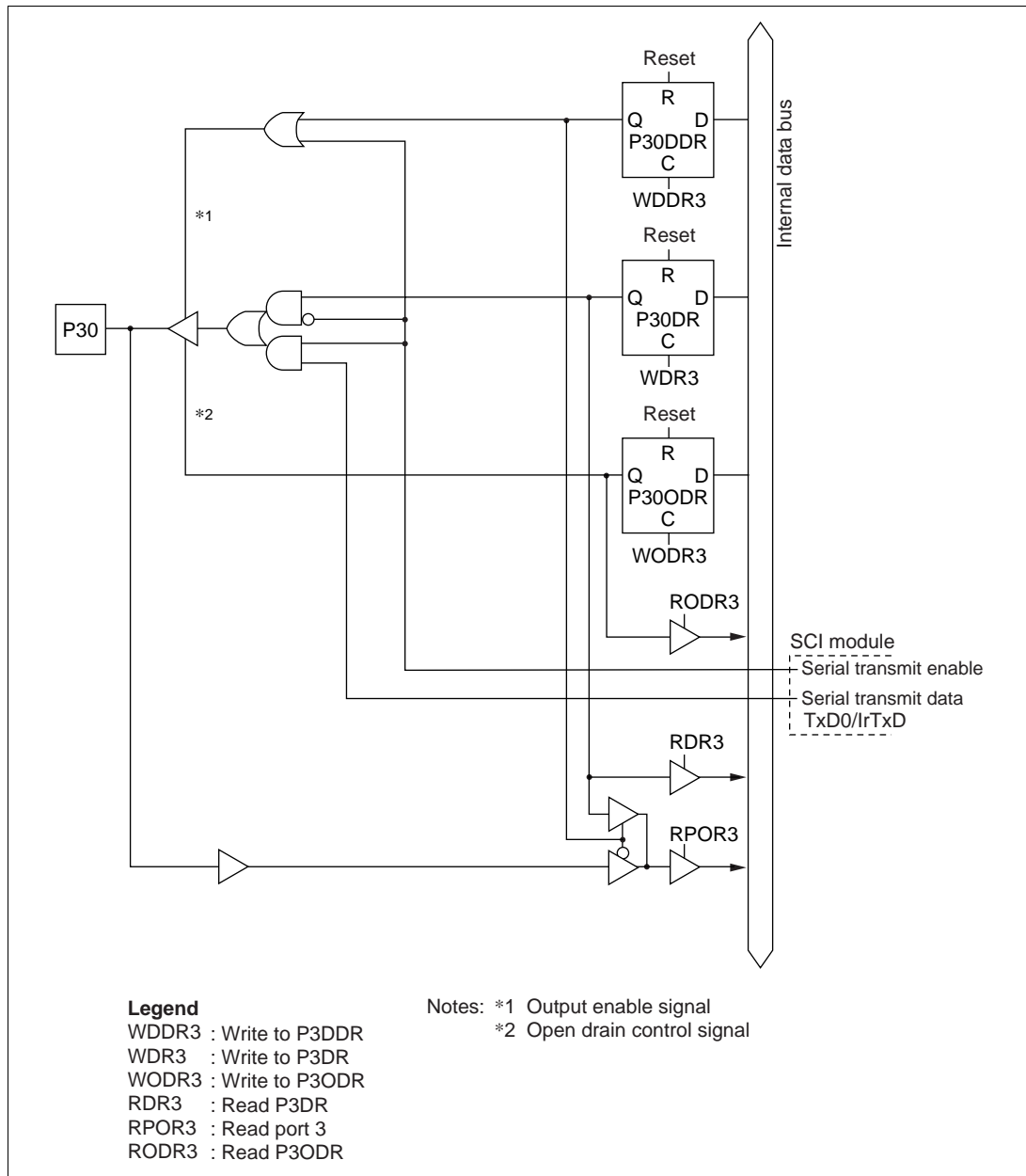
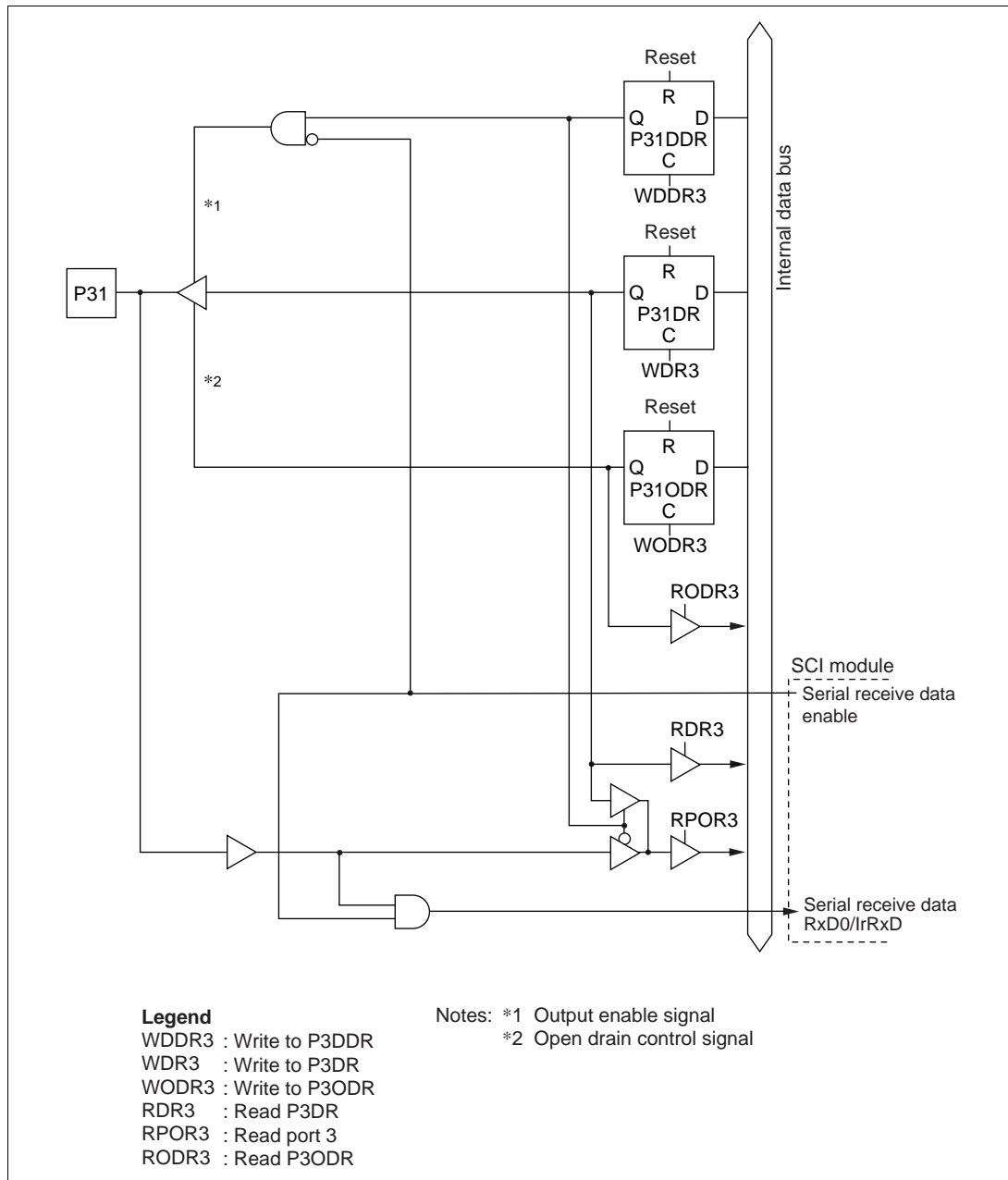


Figure C-14 (a) Port 3 Block Diagram (Pin P30)



**Figure C-14 (b) Port 3 Block Diagram (Pin P31)**

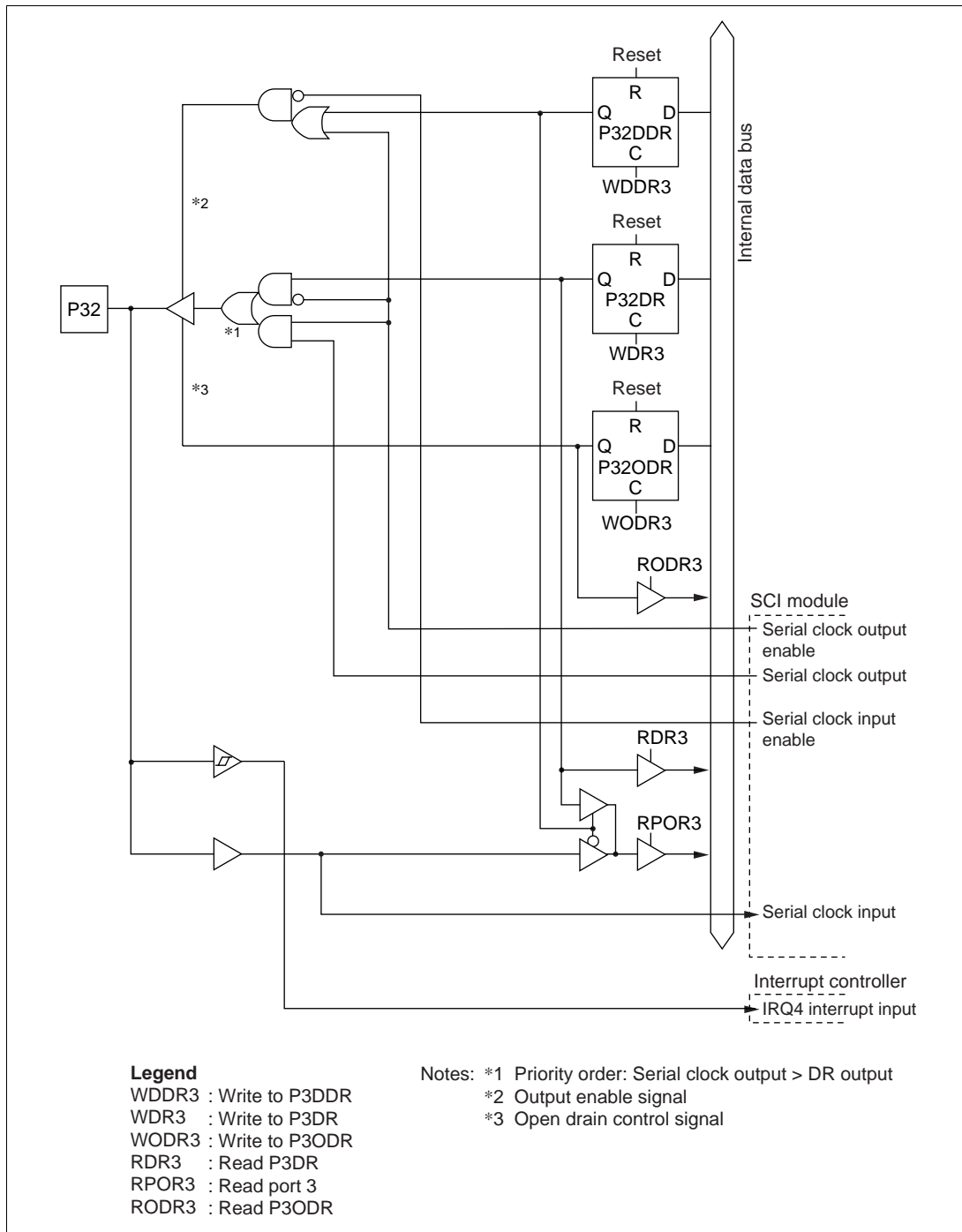


Figure C-14 (c) Port 3 Block Diagram (Pin P32)

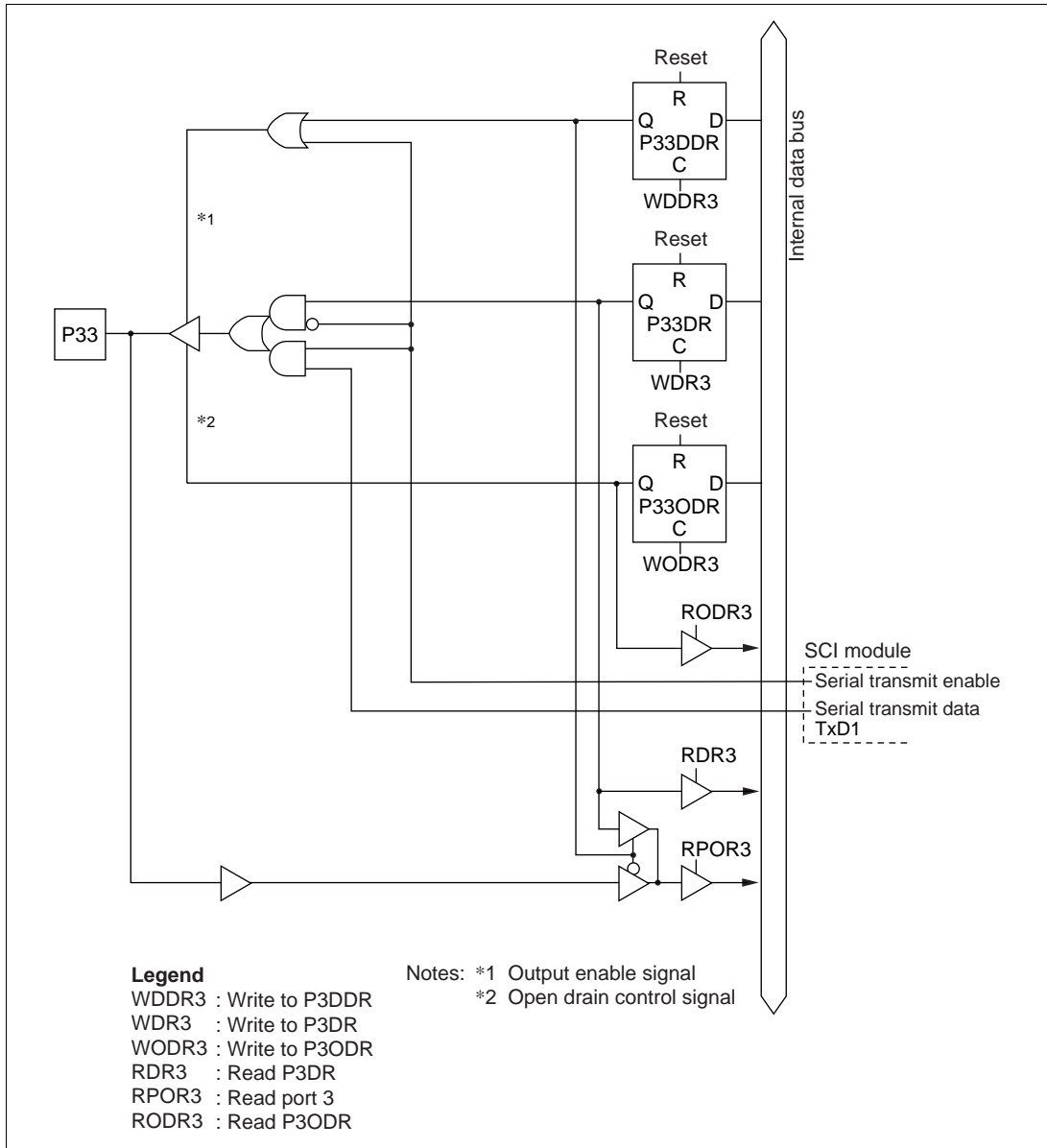


Figure C-14 (d) Port 3 Block Diagram (Pin P33)

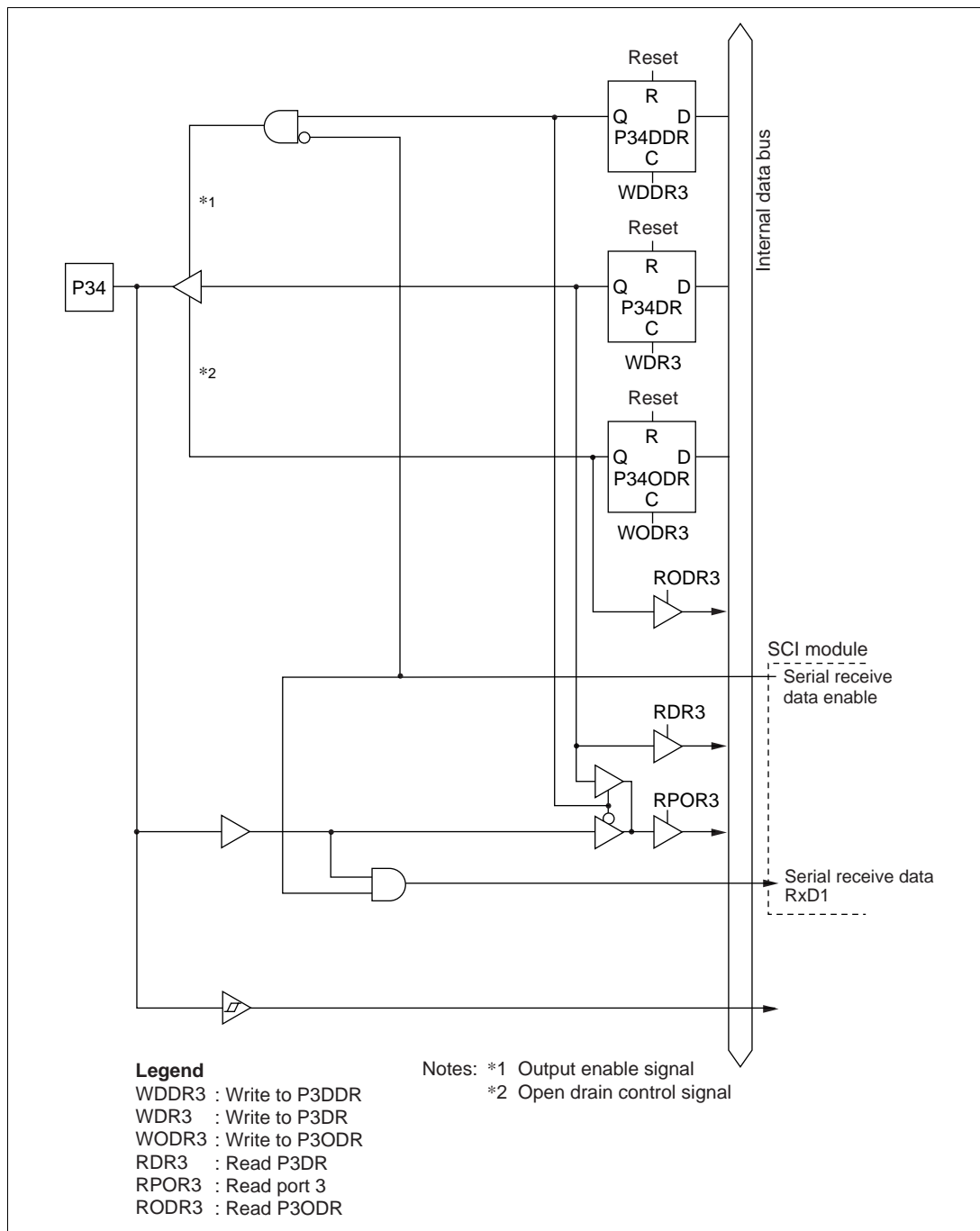


Figure C-14 (e) Port 3 Block Diagram (Pin P34)

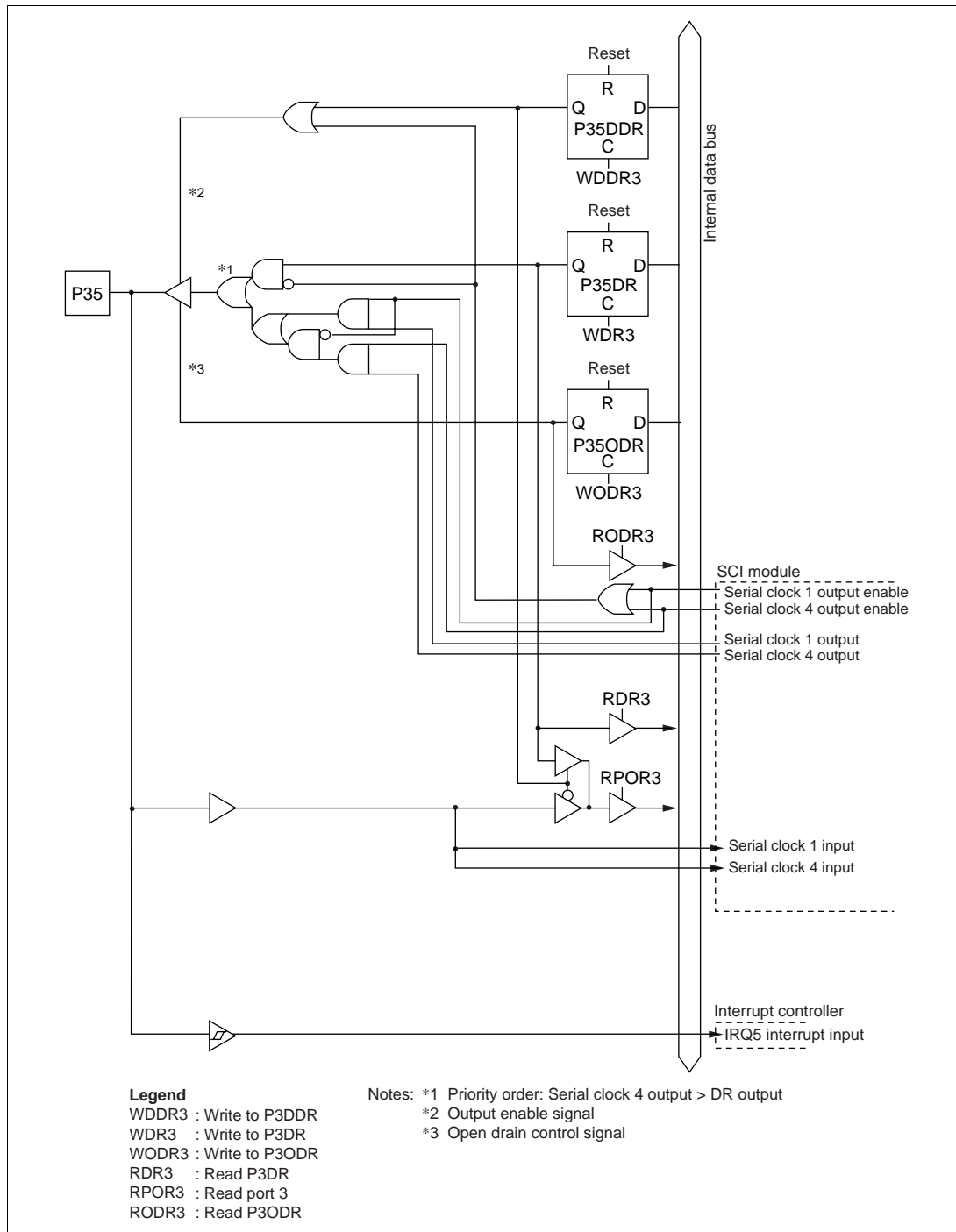


Figure C-14 (f) Port 3 Block Diagram (Pin P35)



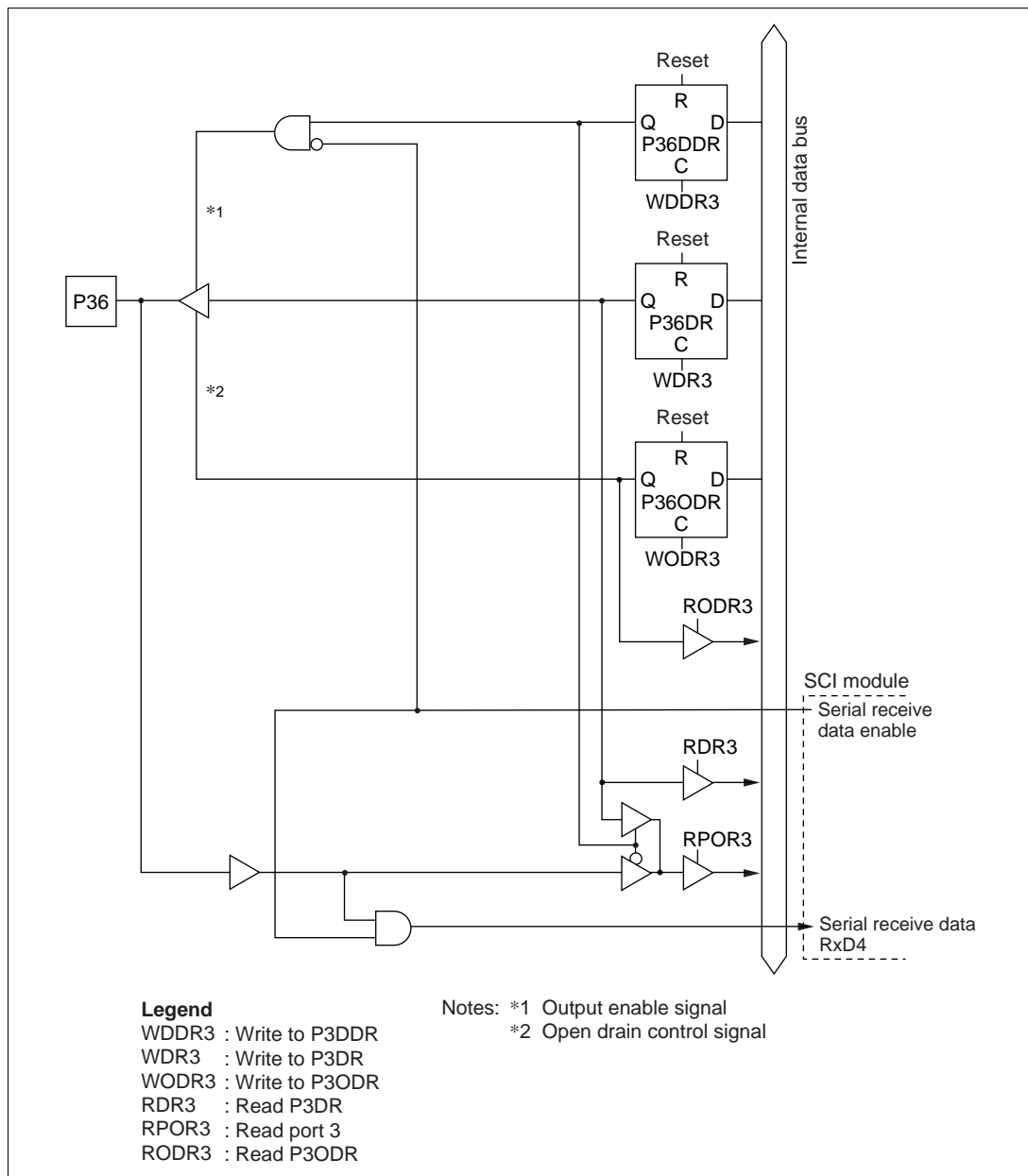
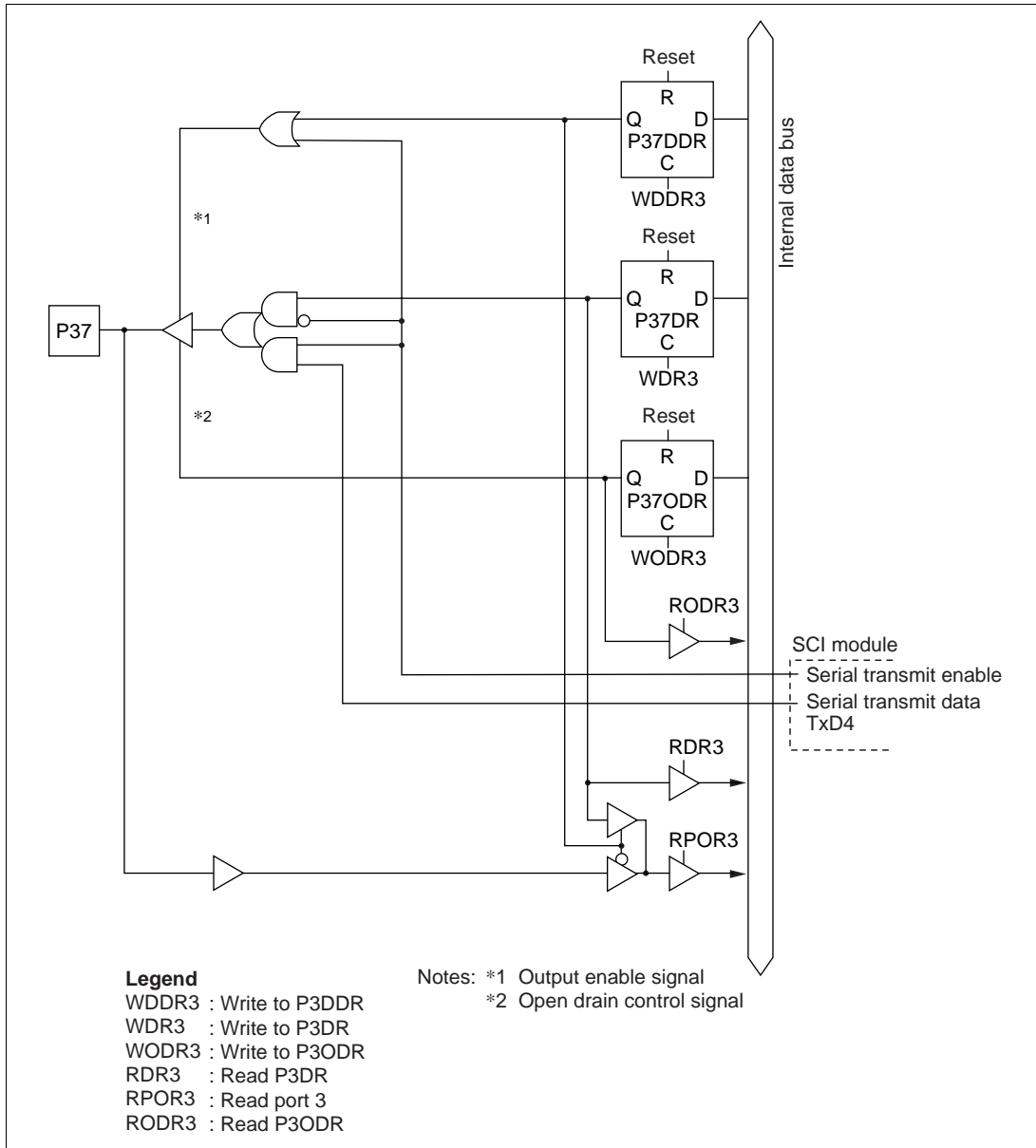


Figure C-14 (g) Port 3 Block Diagram (Pin P36)



**Figure C-14 (h) Port 3 Block Diagram (Pin P37)**

## C.15 Port 4 Block Diagram

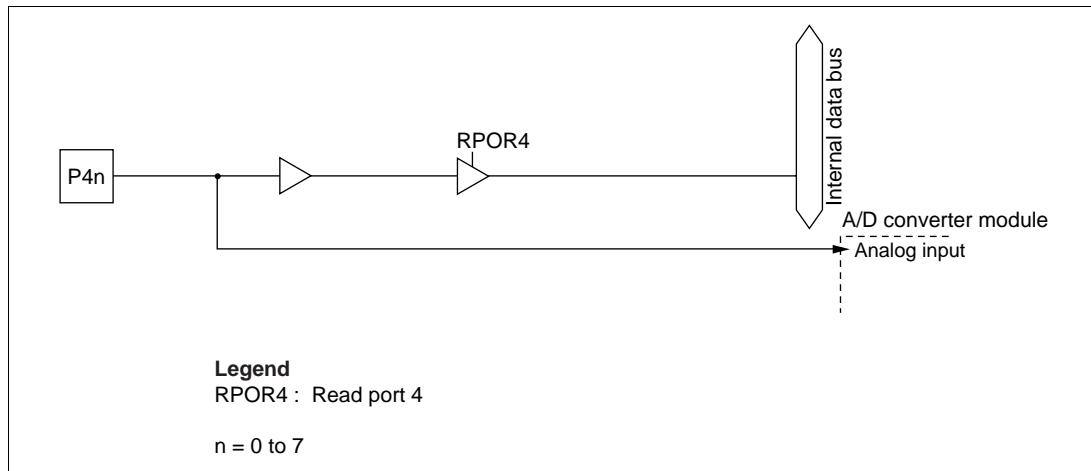


Figure C-15 Port 4 Block Diagram (Pins P40 to P47)

## C.16 Port 7 Block Diagram

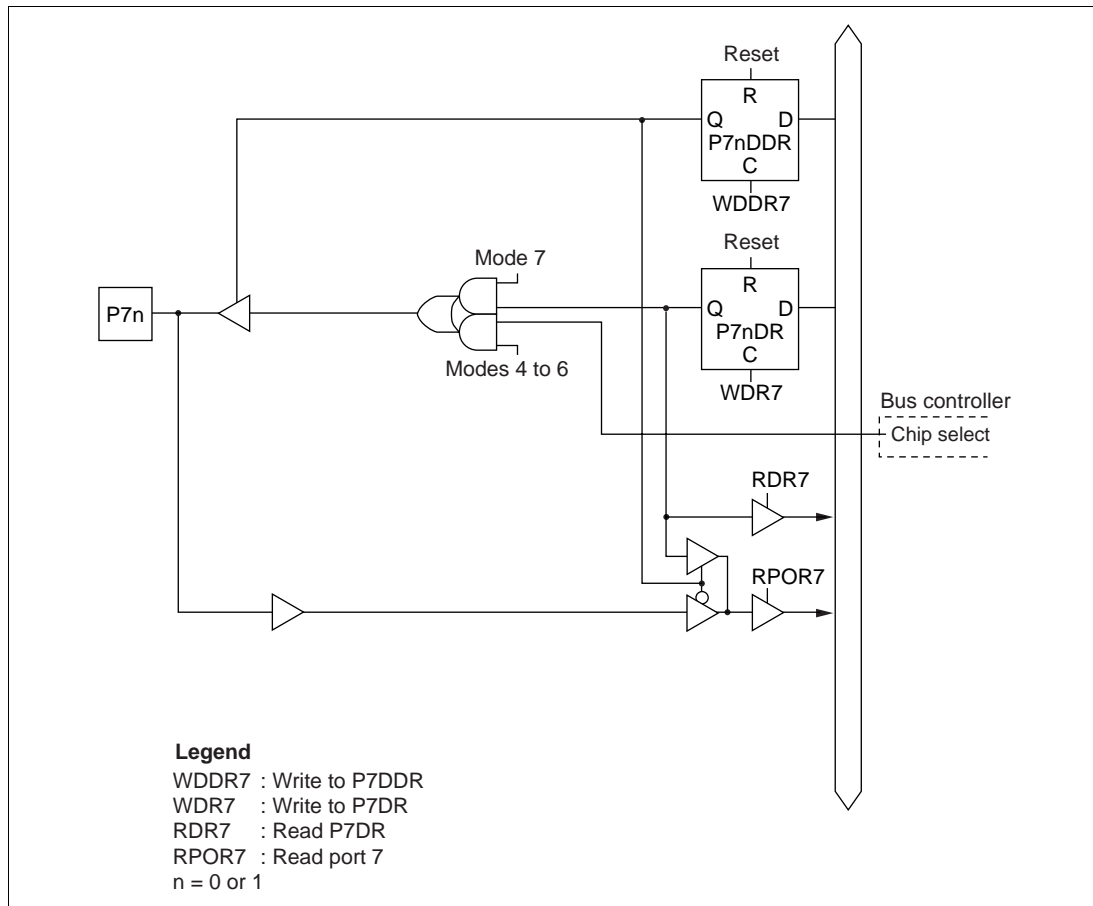
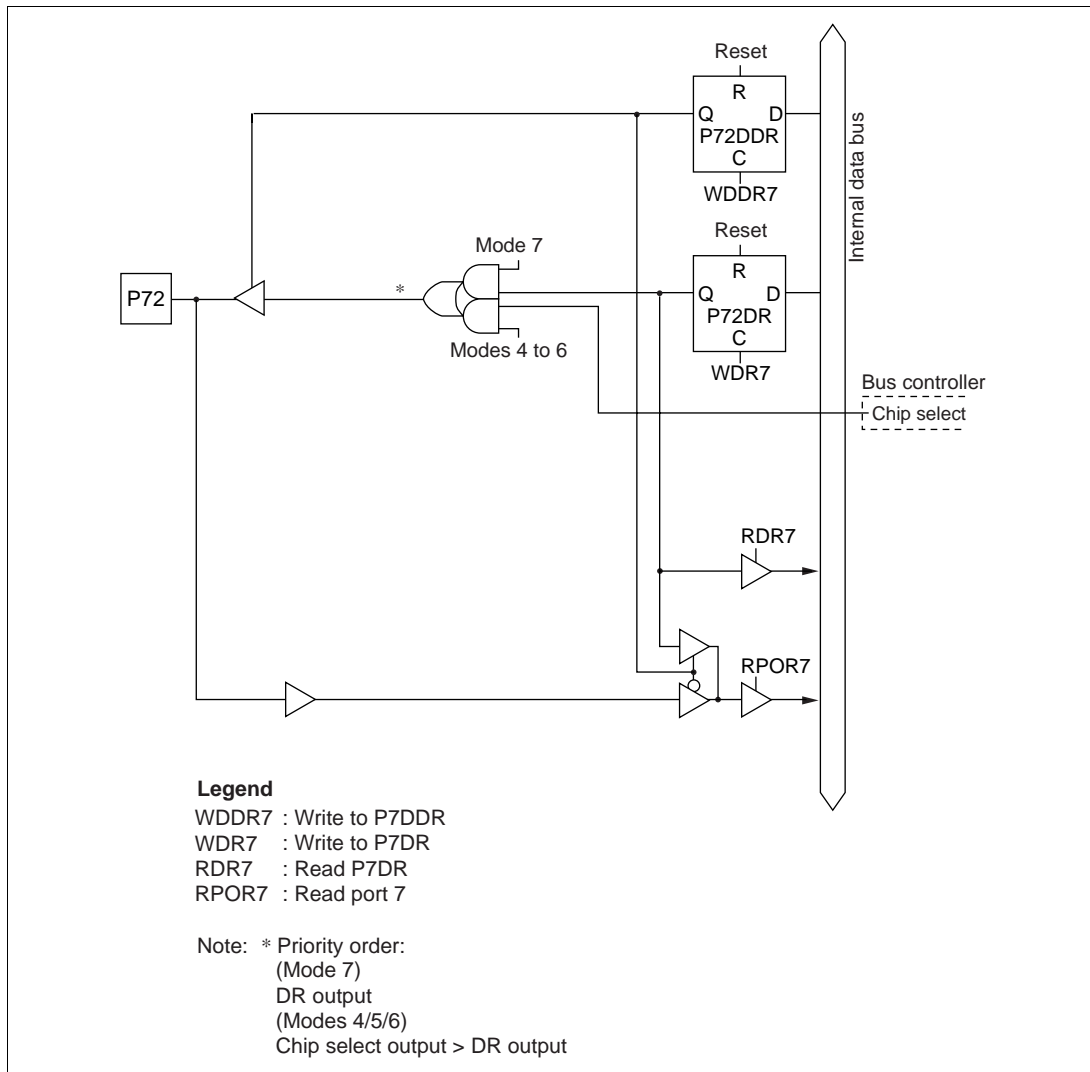
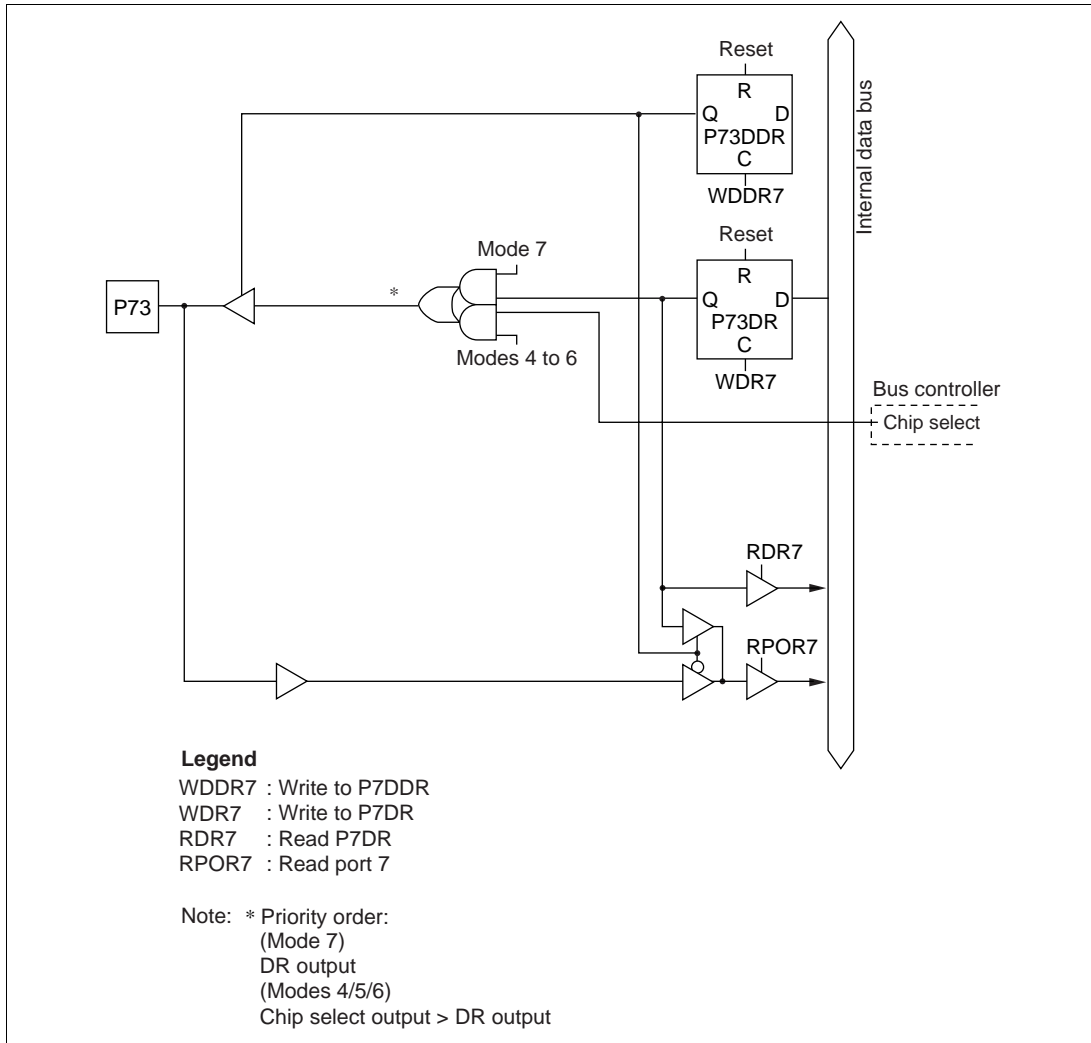


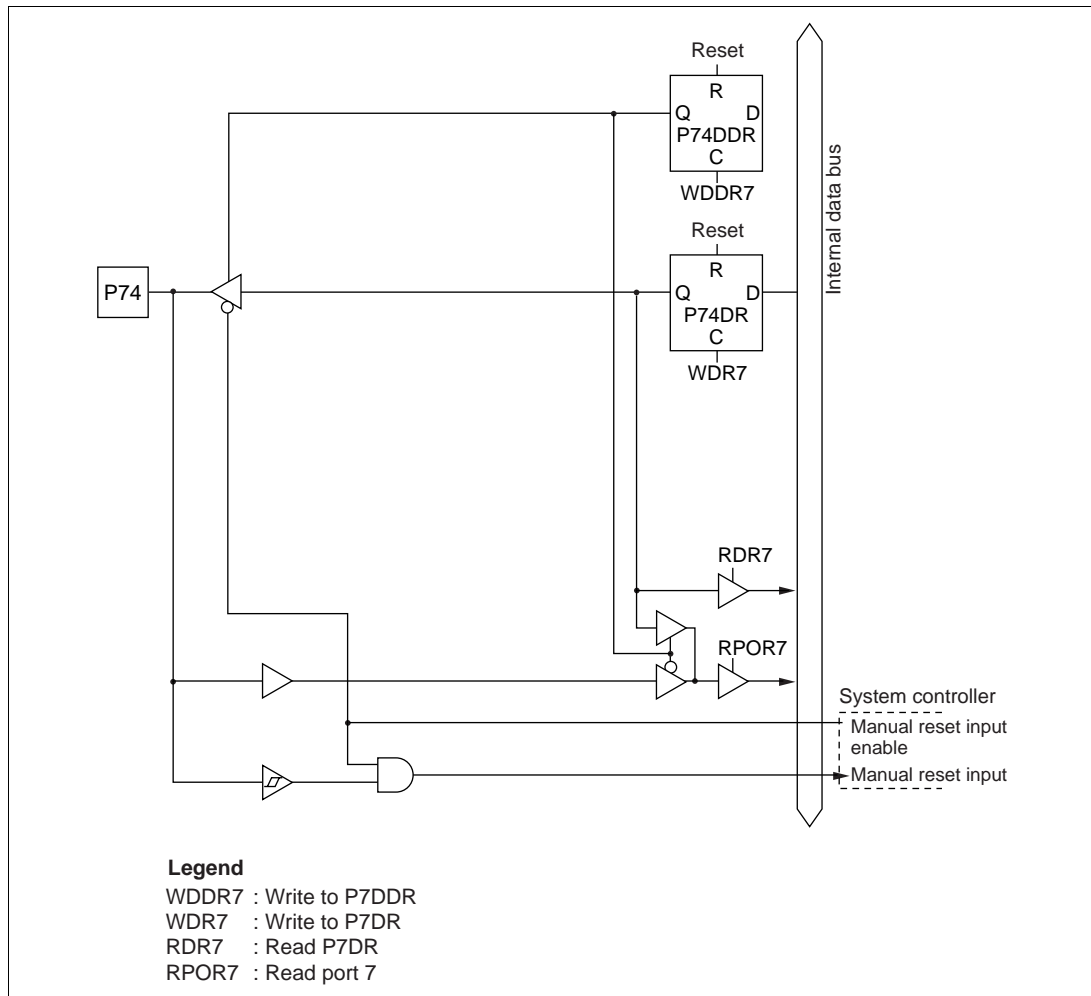
Figure C-16 (a) Port 7 Block Diagram (Pins P70 and P71)



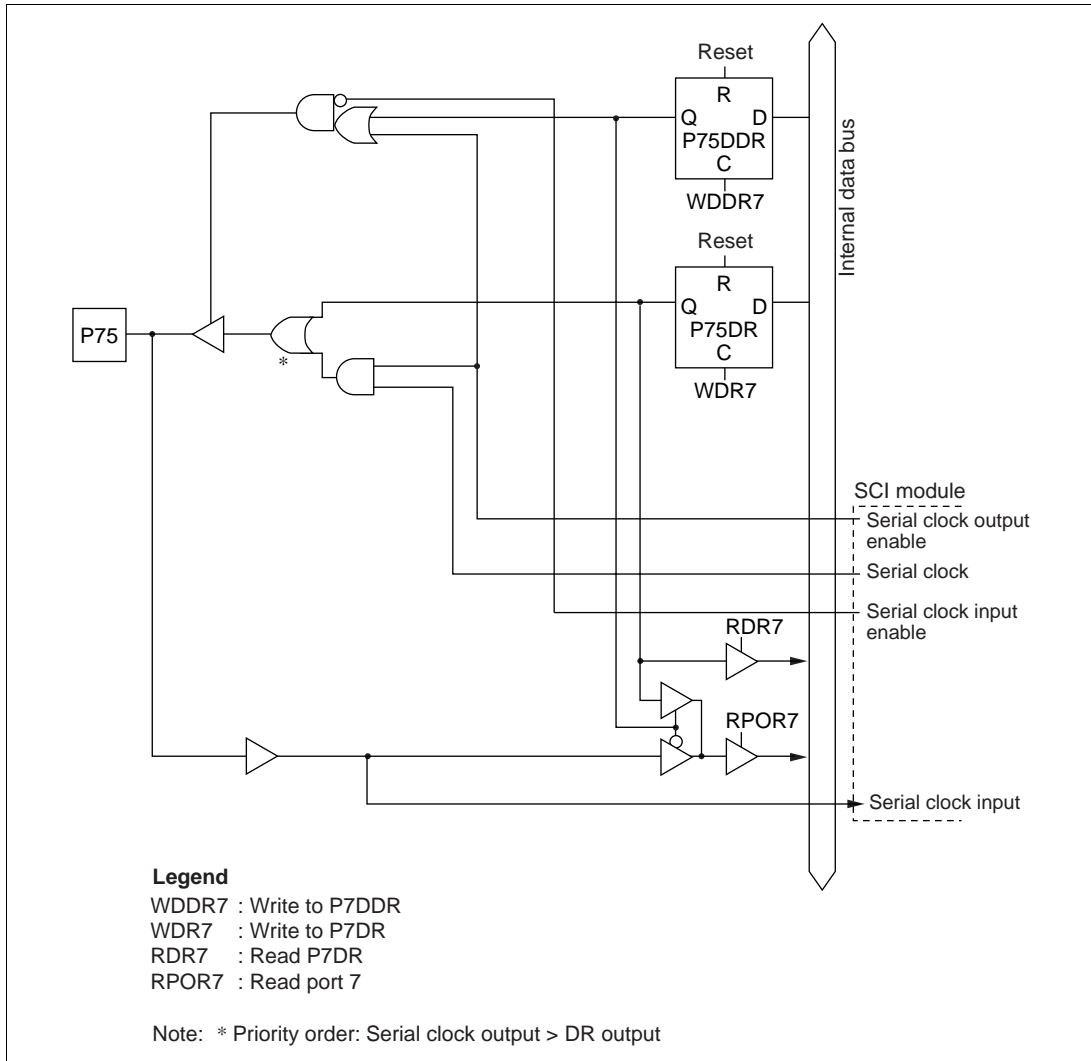
**Figure C-16 (b) Port 7 Block Diagram (Pin P72)**



**Figure C-16 (c) Port 7 Block Diagram (Pin P73)**



**Figure C-16 (d) Port 7 Block Diagram (Pin P74)**



**Figure C-16 (e) Port 7 Block Diagram (Pin P75)**



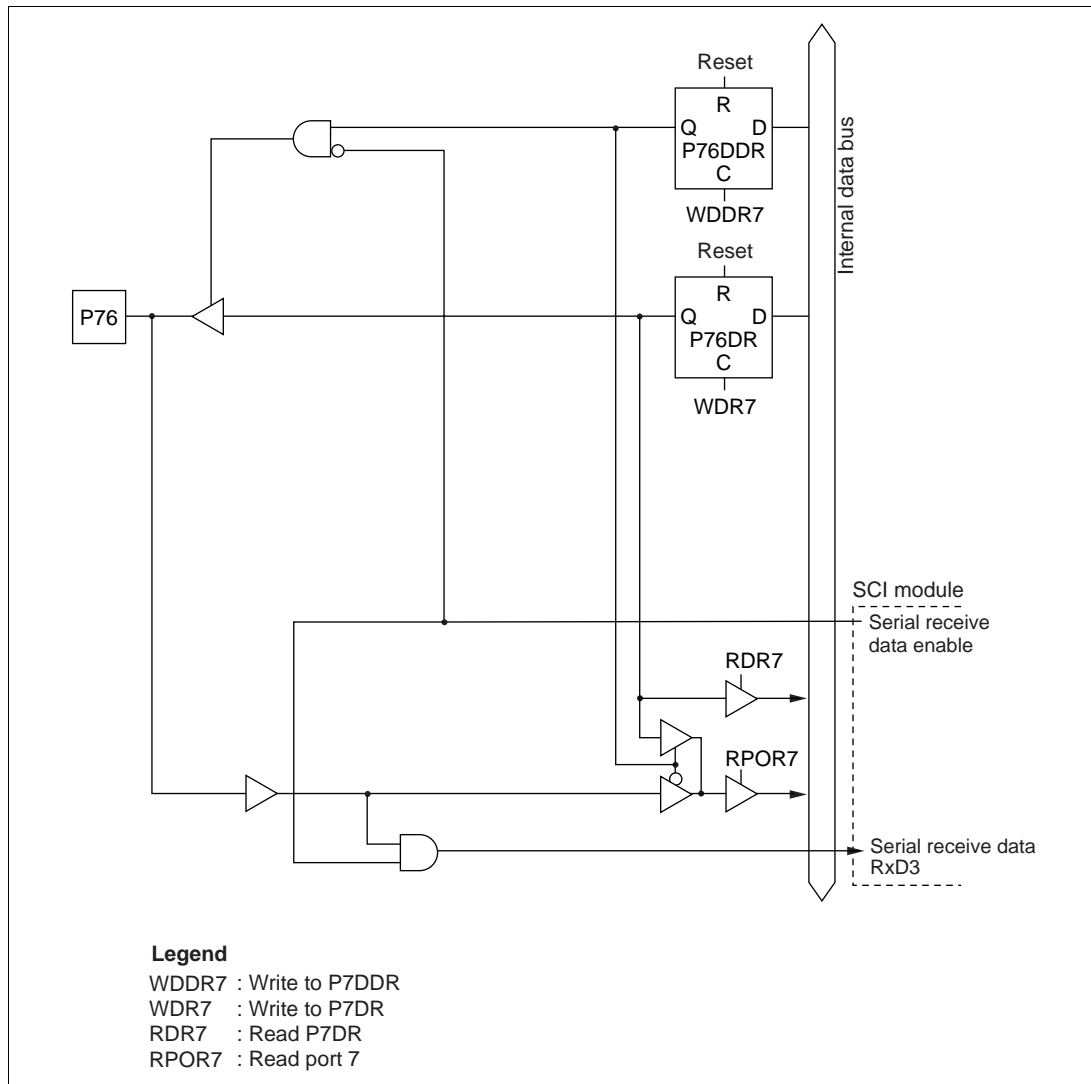


Figure C-16 (f) Port 7 Block Diagram (Pin P76)

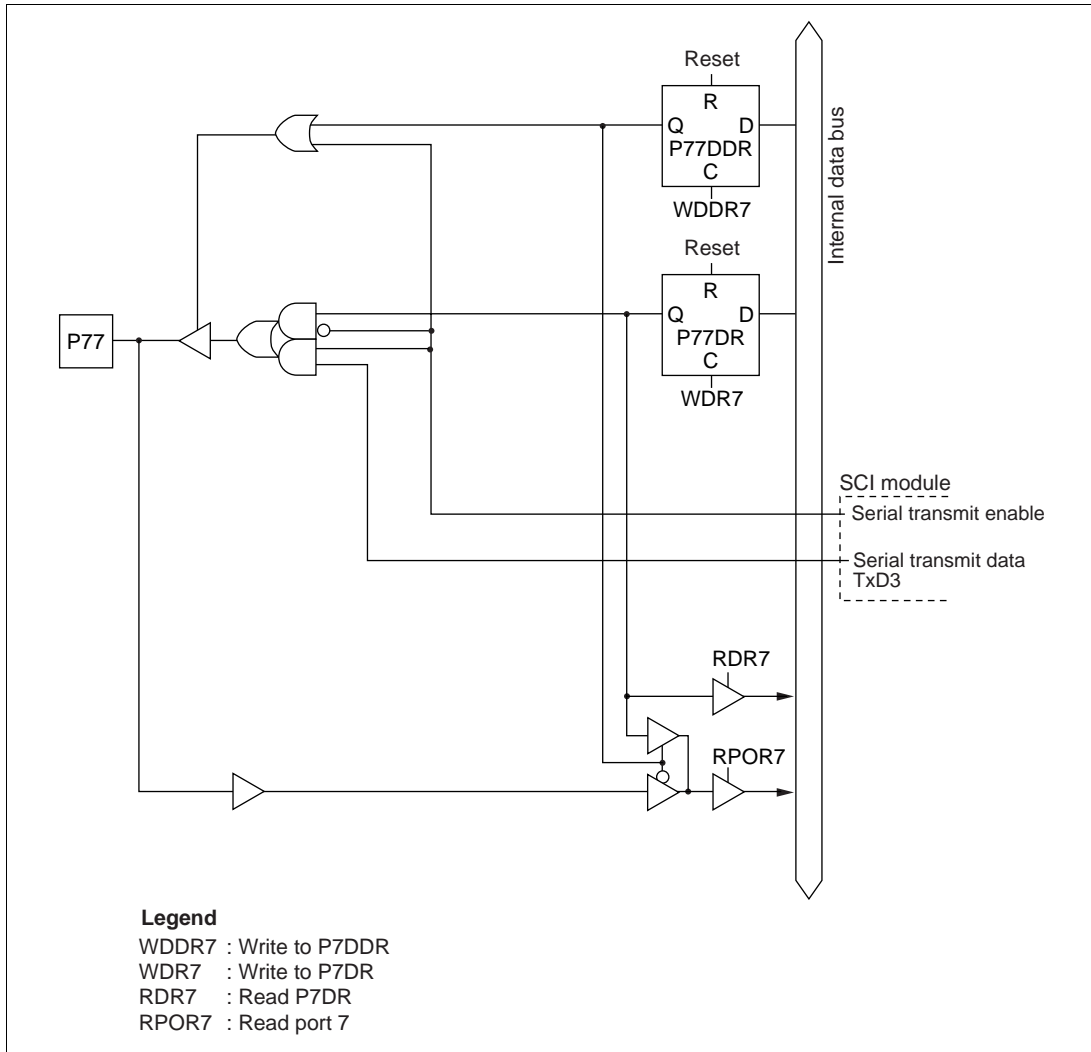


Figure C-16 (g) Port 7 Block Diagram (Pin P77)

## C.17 Port 9 Block Diagram

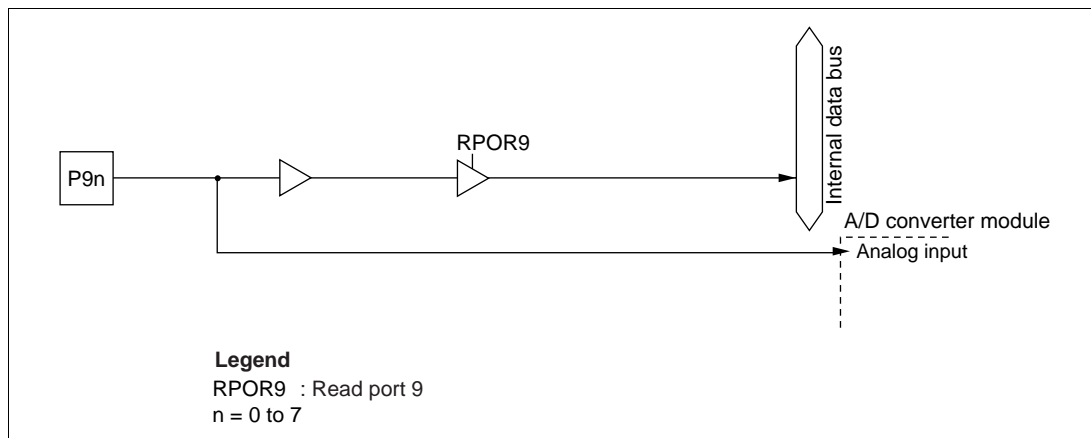
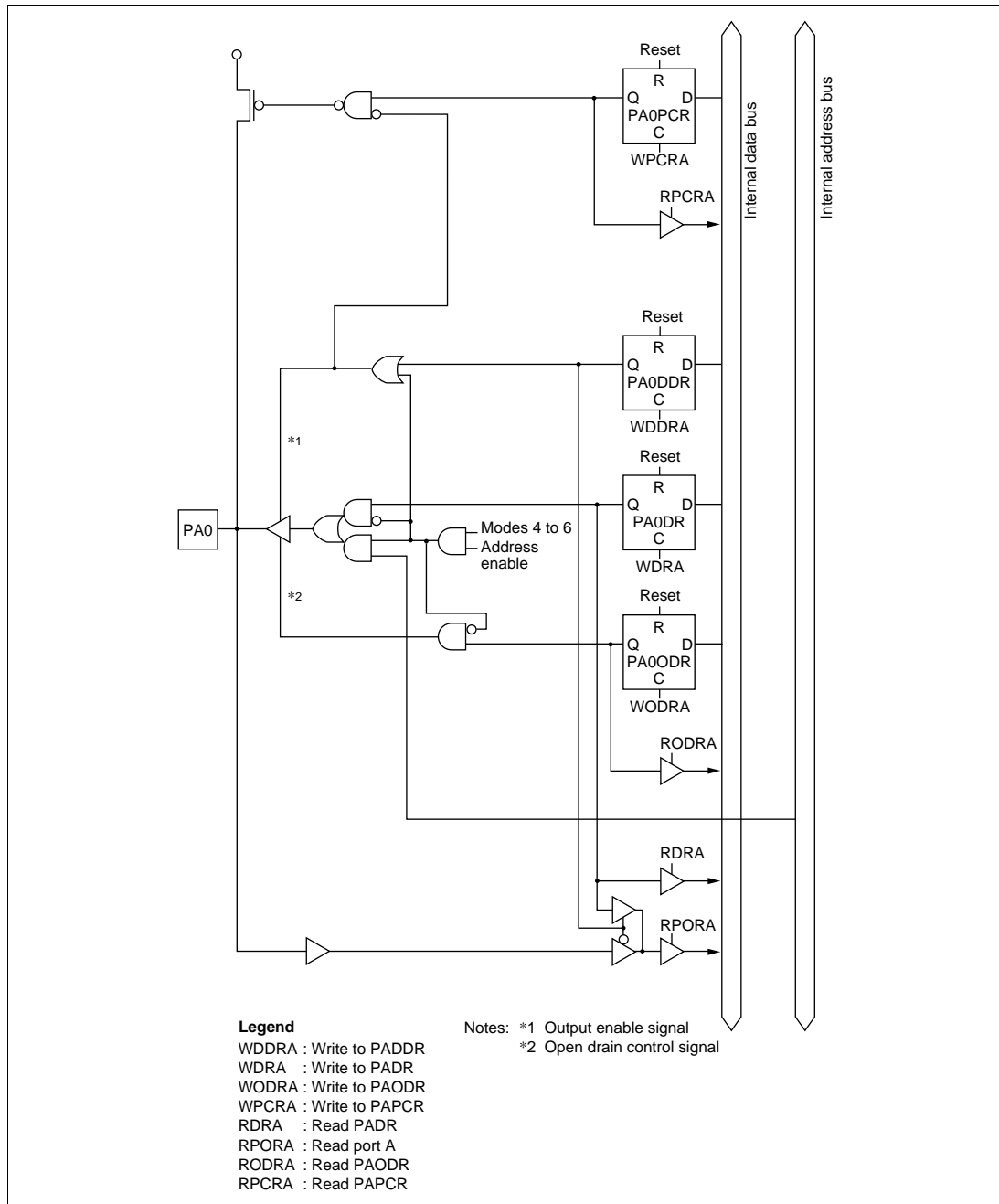


Figure C-17 Port 9 Block Diagram (Pins P90 to P97)

### C.18 Port A Block Diagram



**Figure C-18 (a) Port A Block Diagram (Pin PA0)**

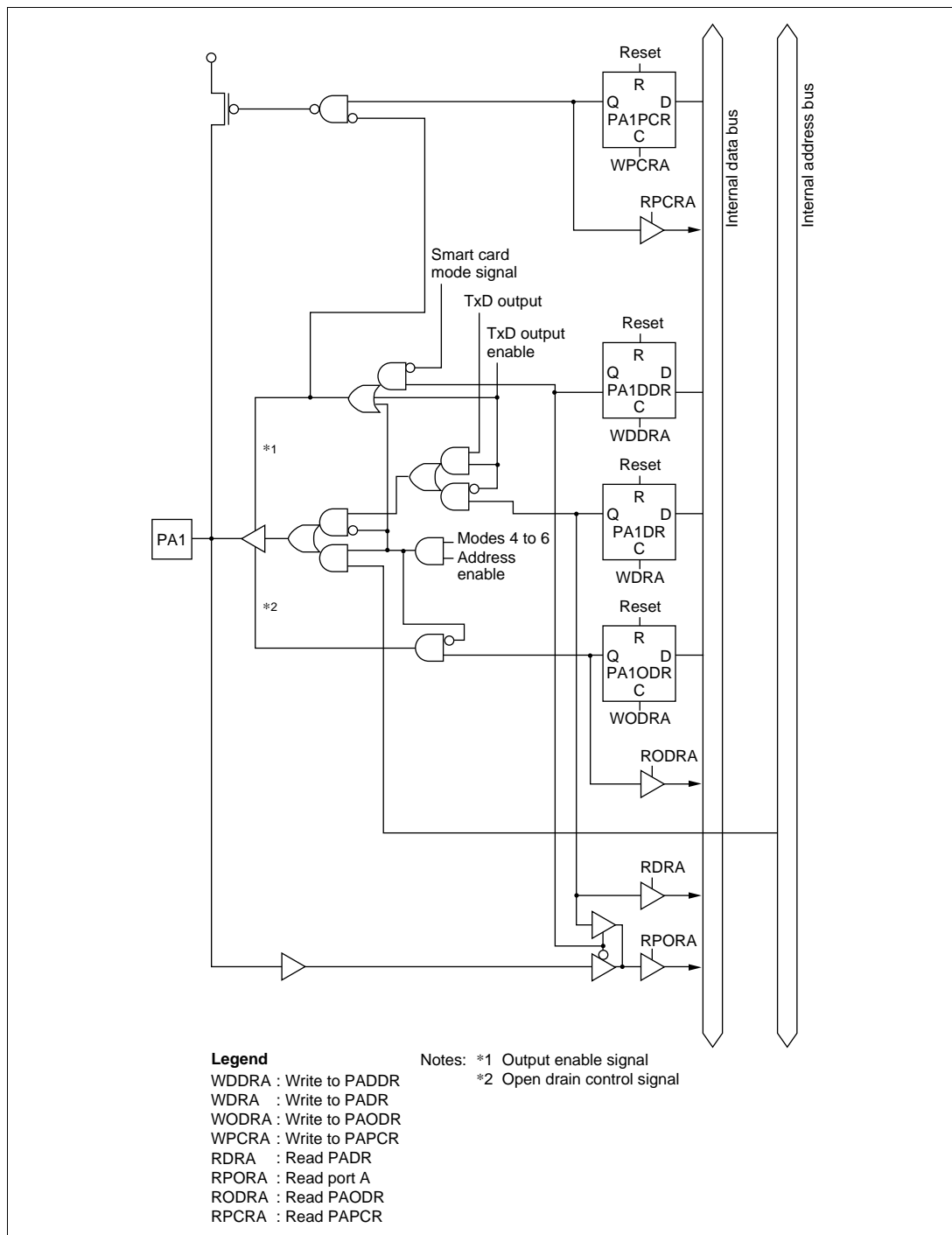
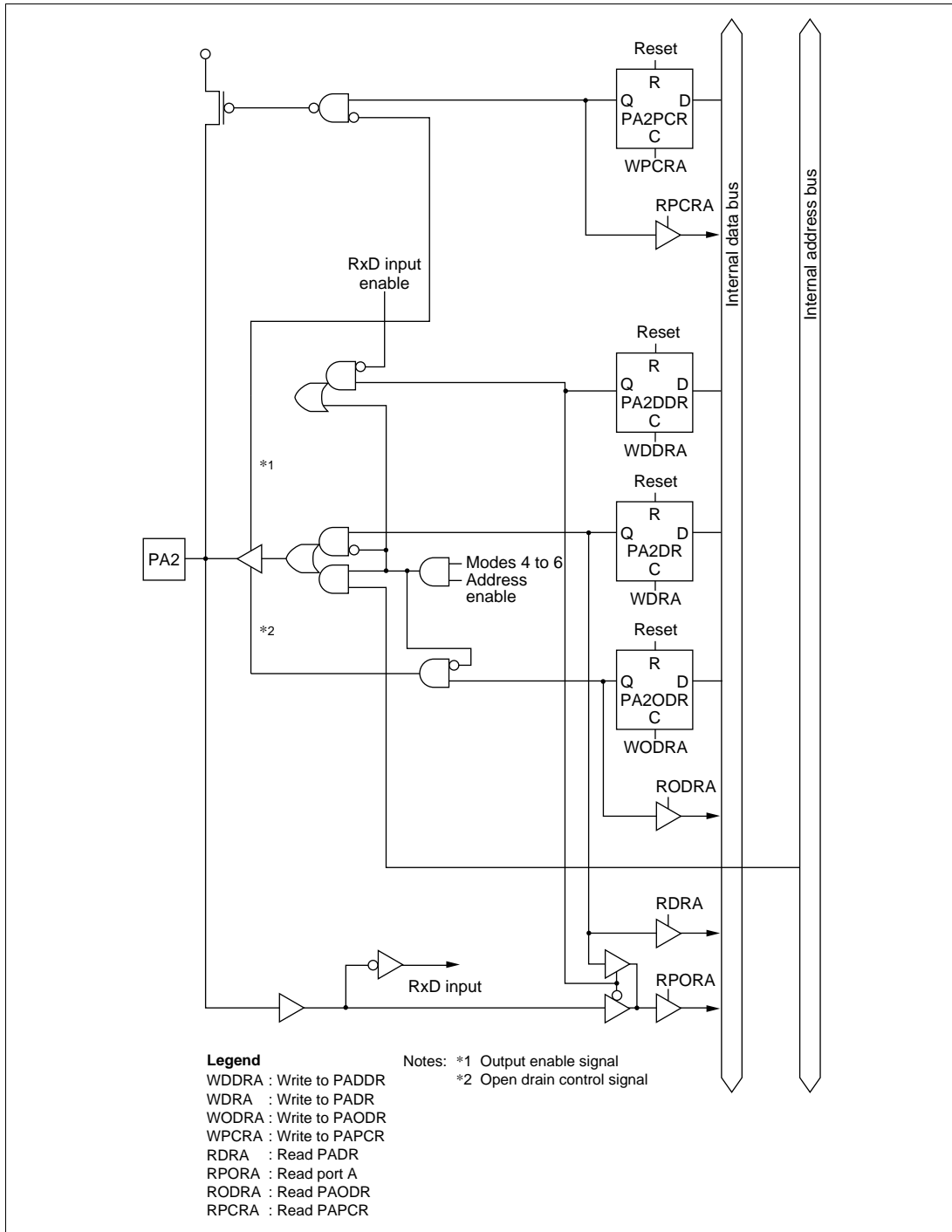


Figure C-18 (b) Port A Block Diagram (Pin PA1)



**Figure C-18 (c) Port A Block Diagram (Pin PA2)**

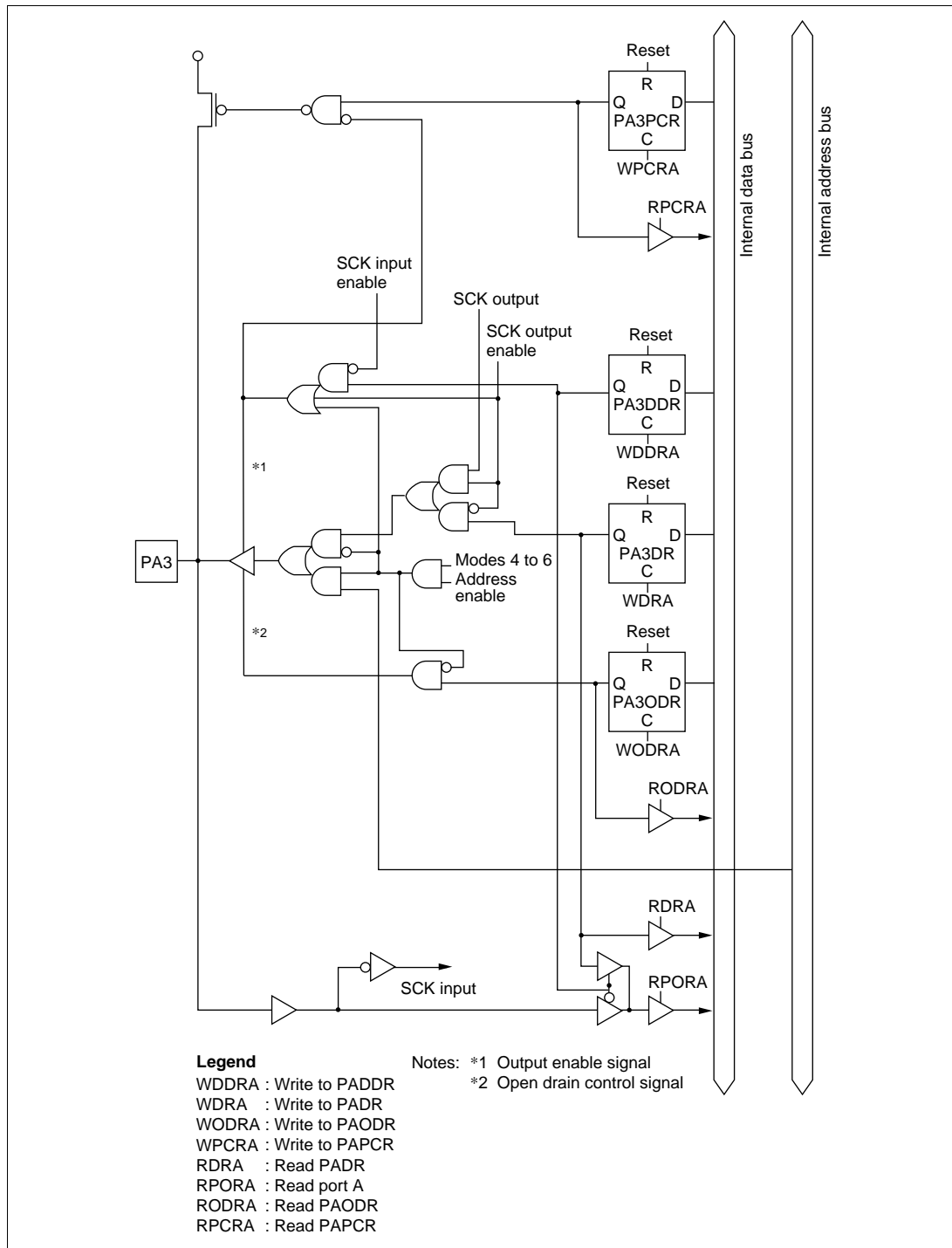


Figure C-18 (d) Port A Block Diagram (Pin PA3)

## C.19 Port B Block Diagram

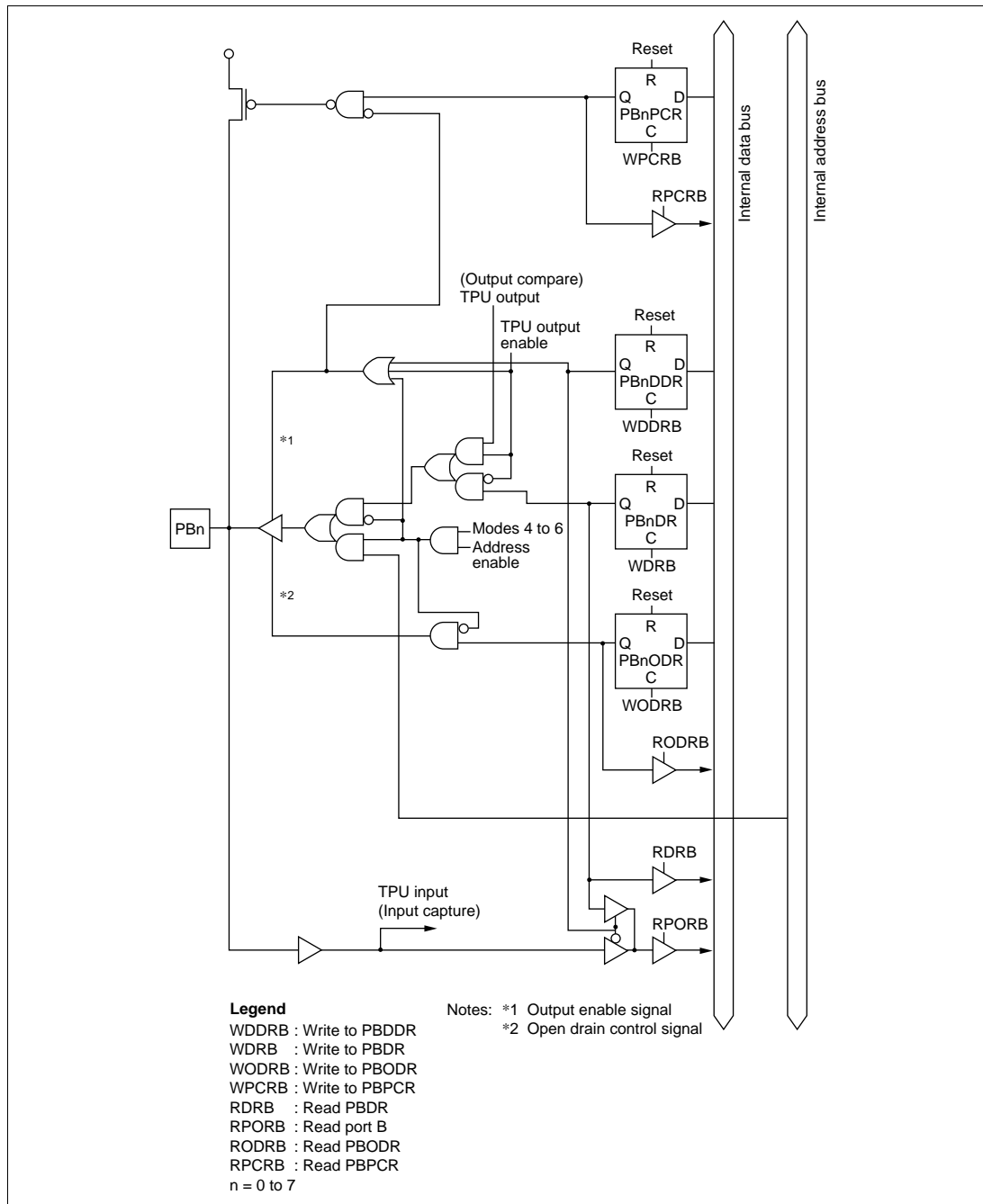


Figure C-19 Port B Block Diagram (Pins PB0 to PB7)



## C.20 Port C Block Diagram

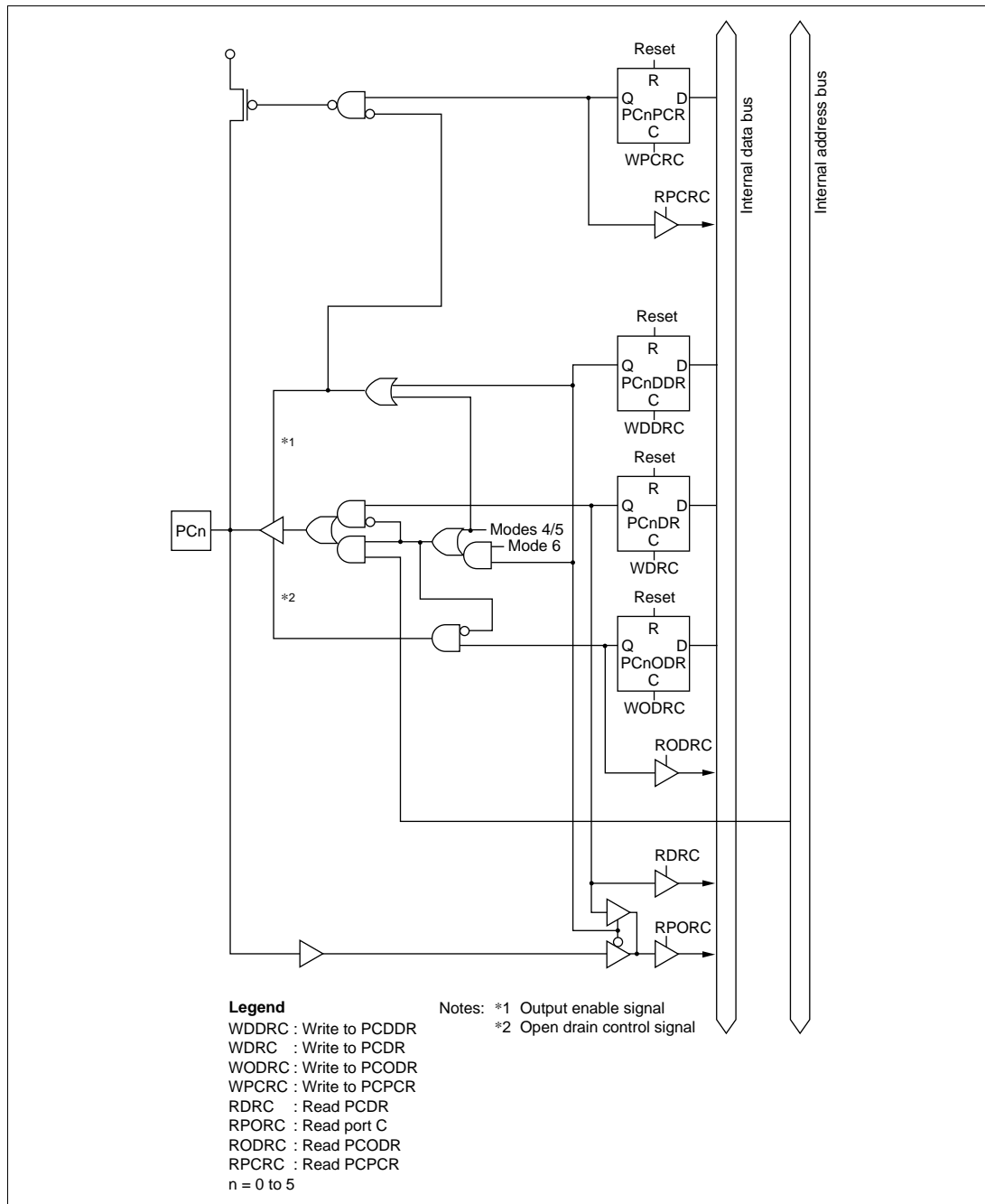
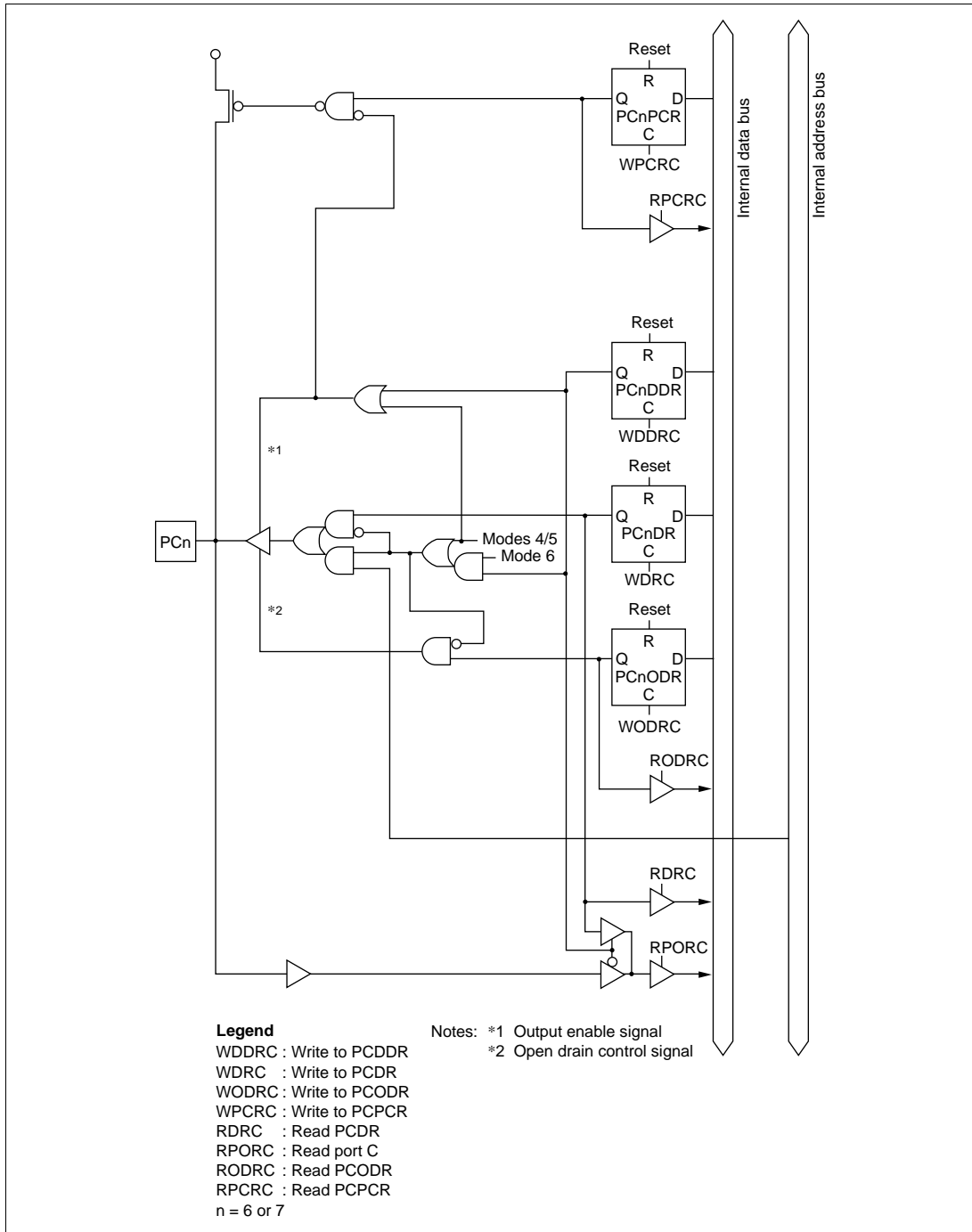


Figure C-20 (a) Port C Block Diagram (Pins PC0 to PC5)



**Figure C-20 (b) Port C Block Diagram (Pins PC6 and PC7)**

## C.21 Port D Block Diagram

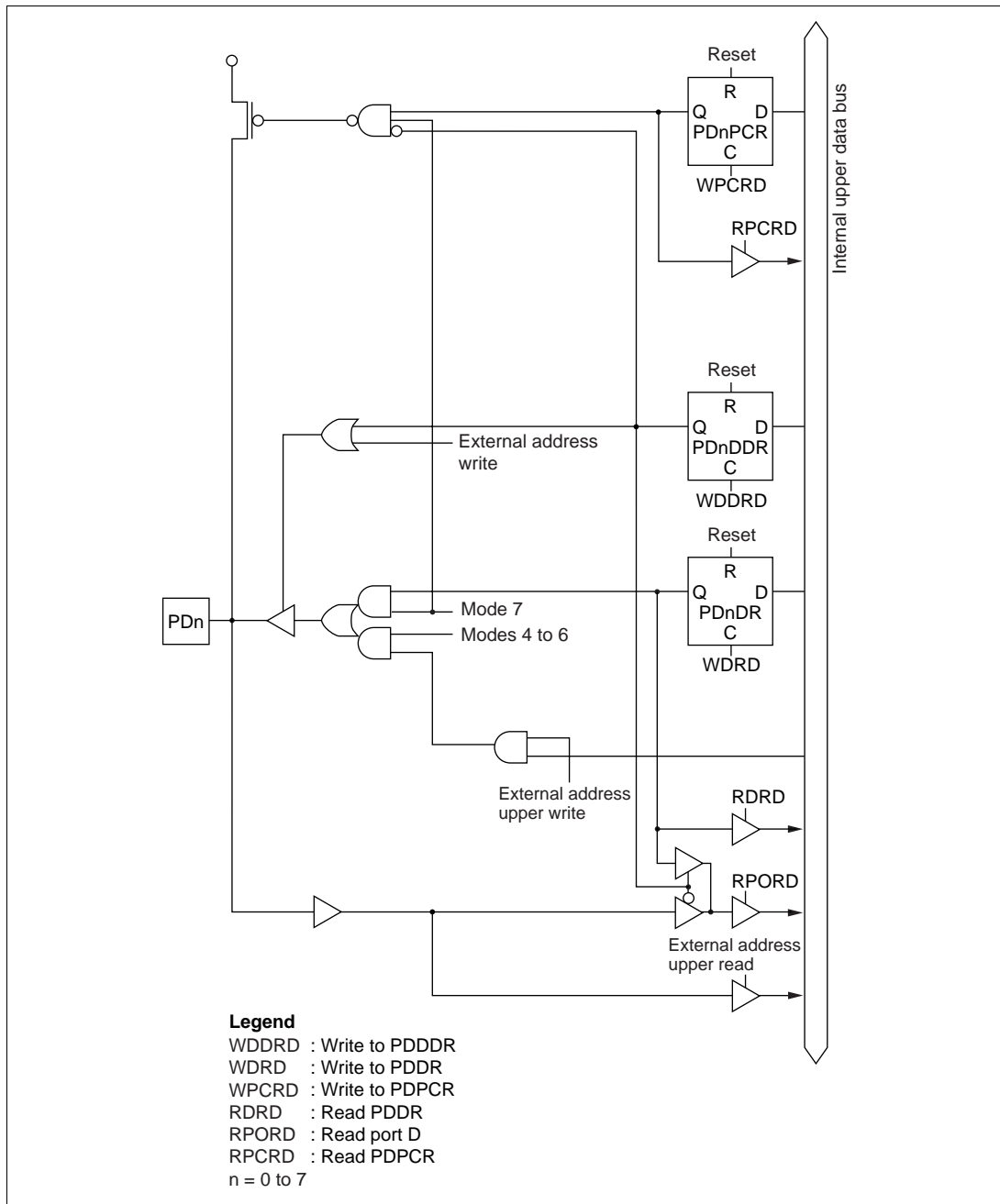


Figure C-21 Port D Block Diagram (Pins PD0 to PD7)

## C.22 Port E Block Diagram

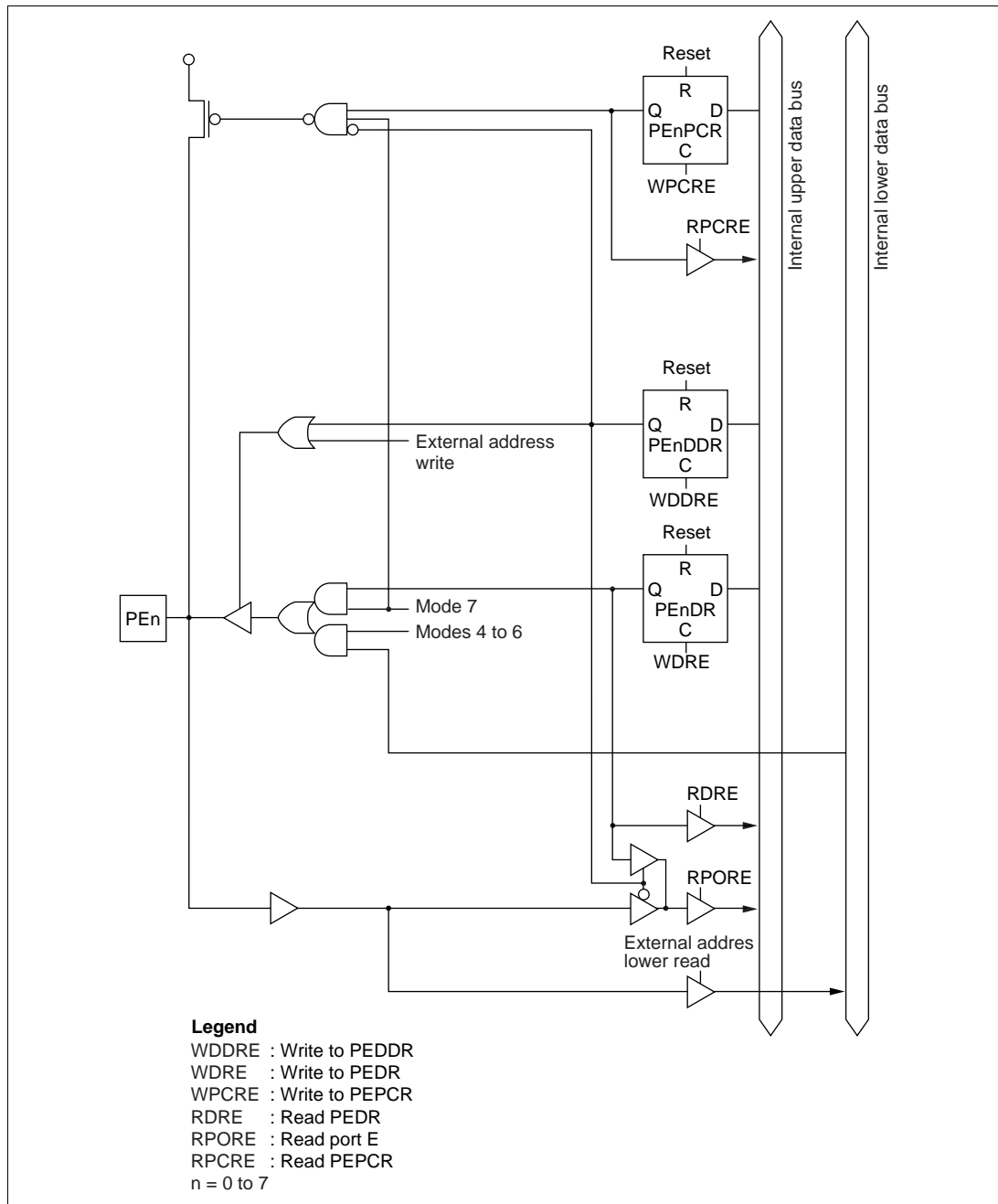


Figure C-22 Port E Block Diagram (Pins PE0 to PE7)

C.23 Port F Block Diagram

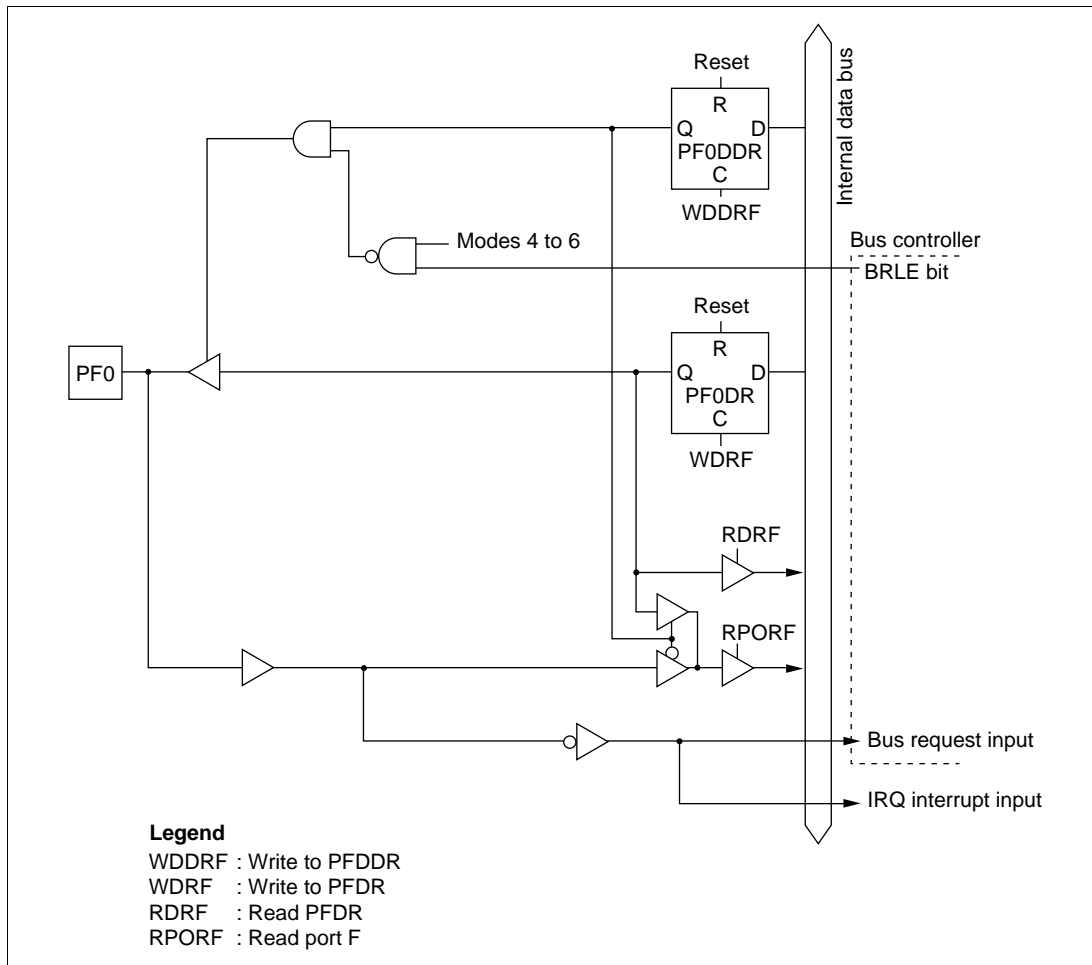


Figure C-23 (a) Port F Block Diagram (Pin PF0)

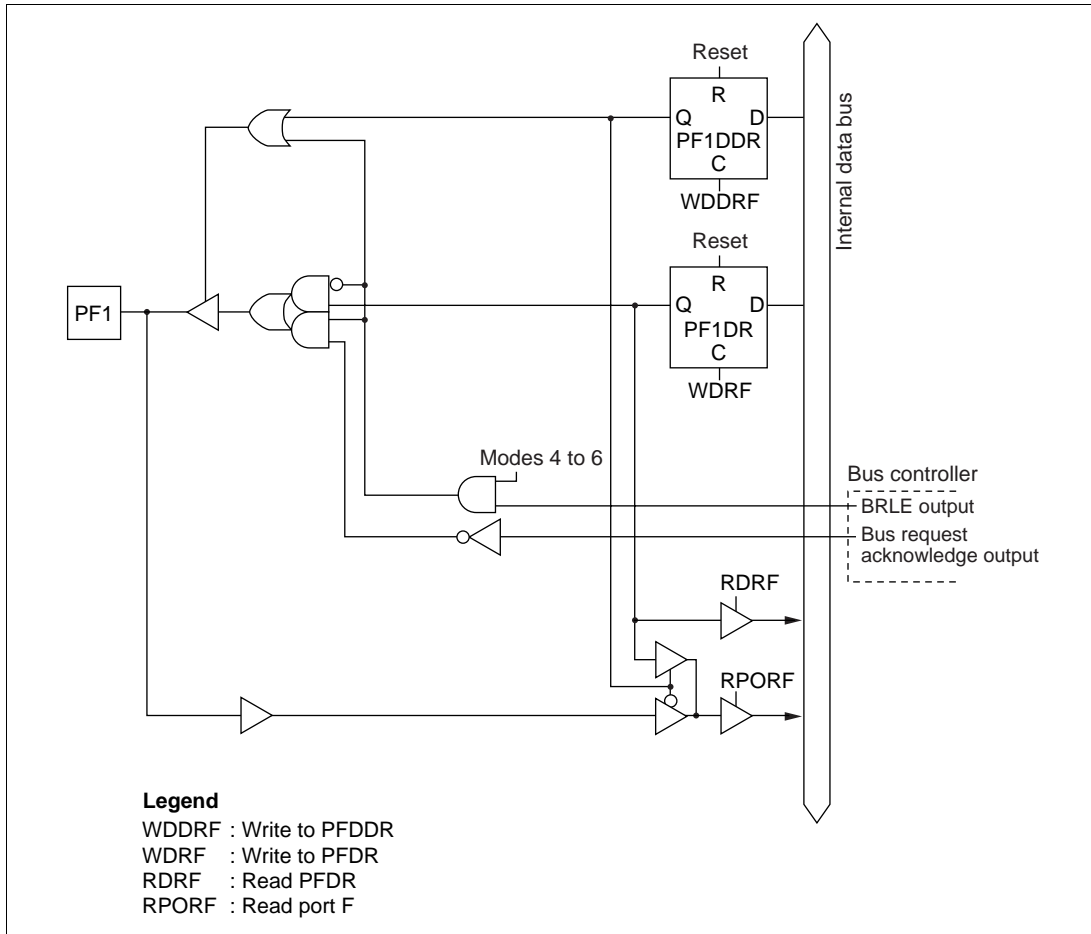


Figure C-23 (b) Port F Block Diagram (Pin PF1)

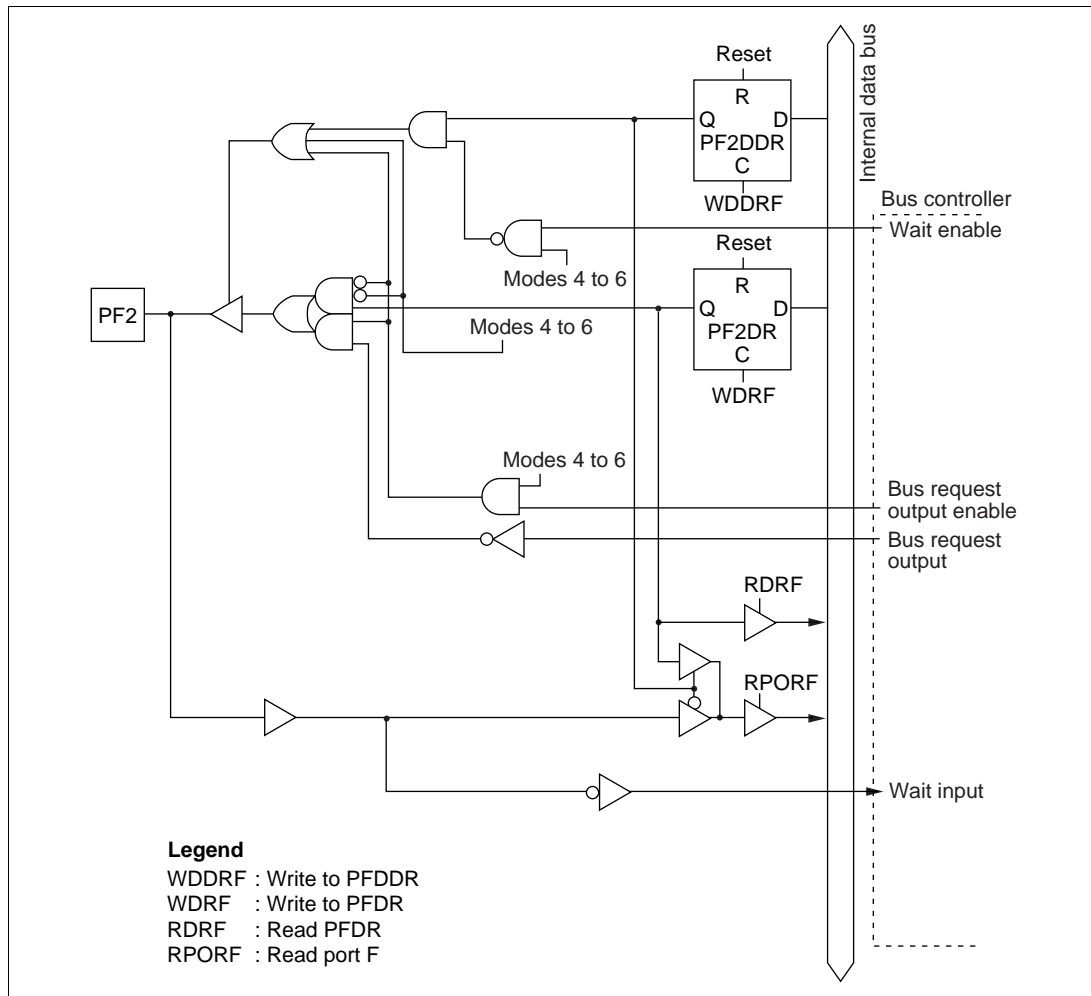


Figure C-23 (c) Port F Block Diagram (Pin PF2)

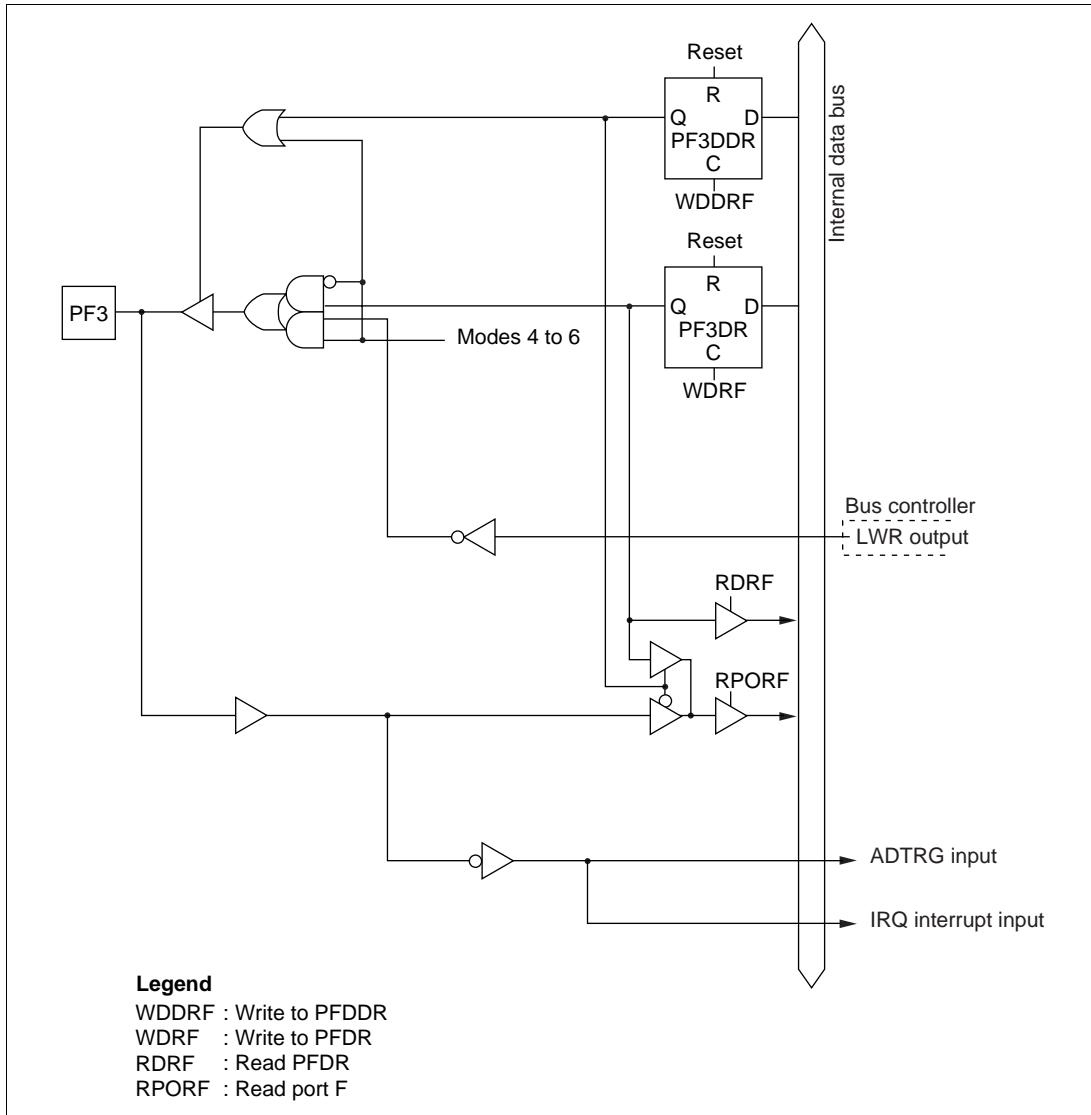


Figure C-23 (d) Port F Block Diagram (Pin PF3)



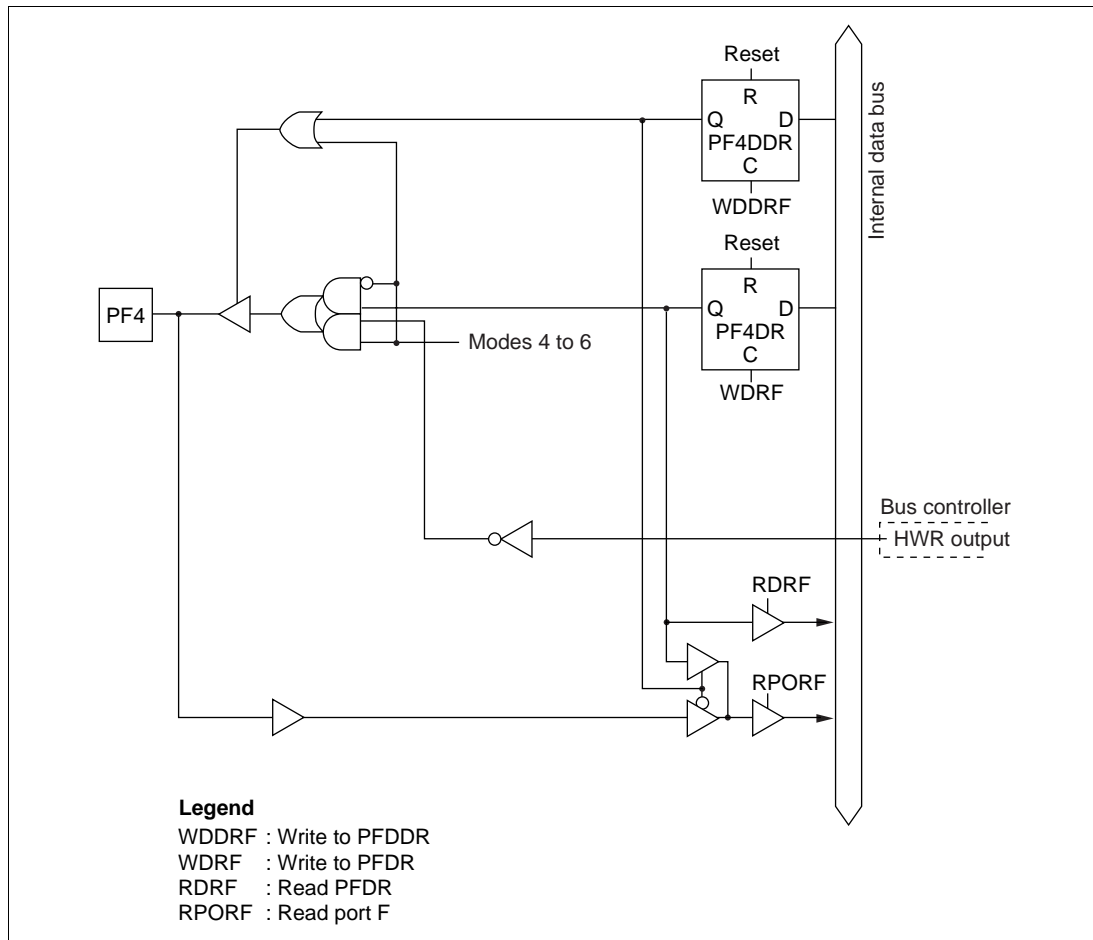


Figure C-23 (e) Port F Block Diagram (Pin PF4)

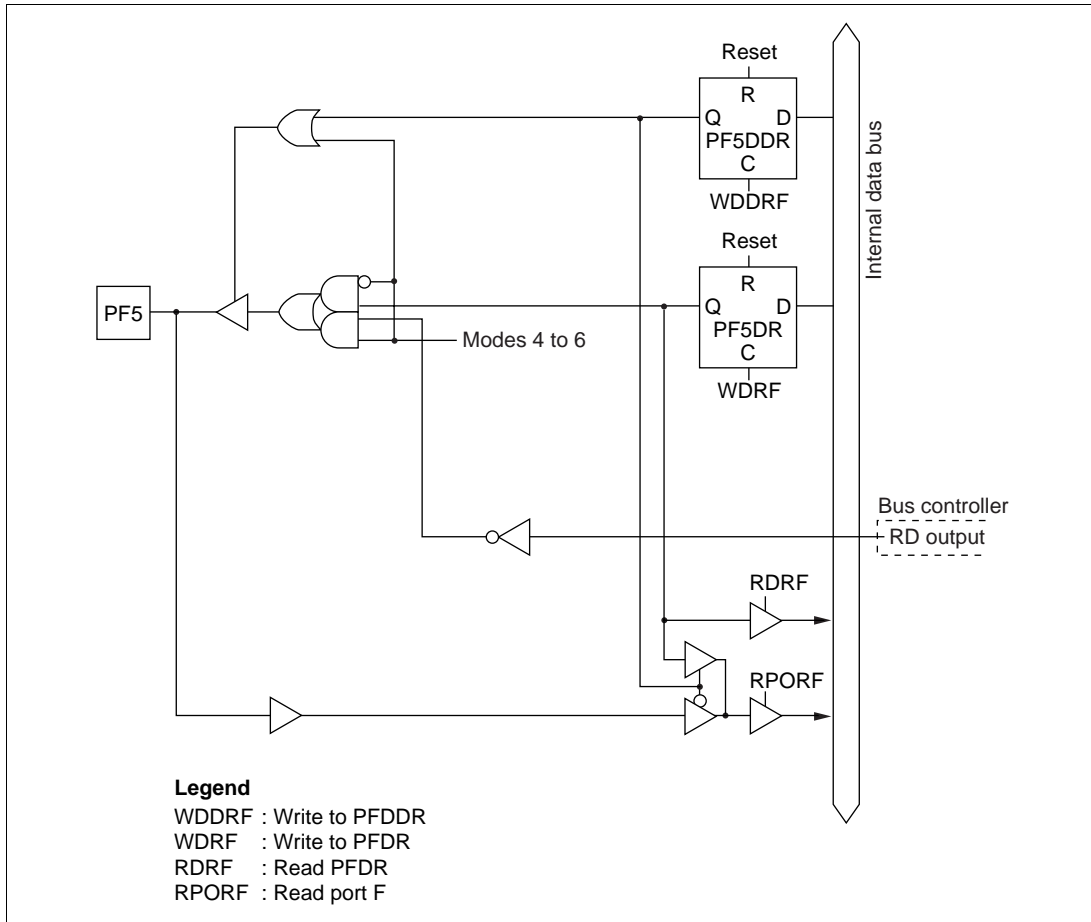
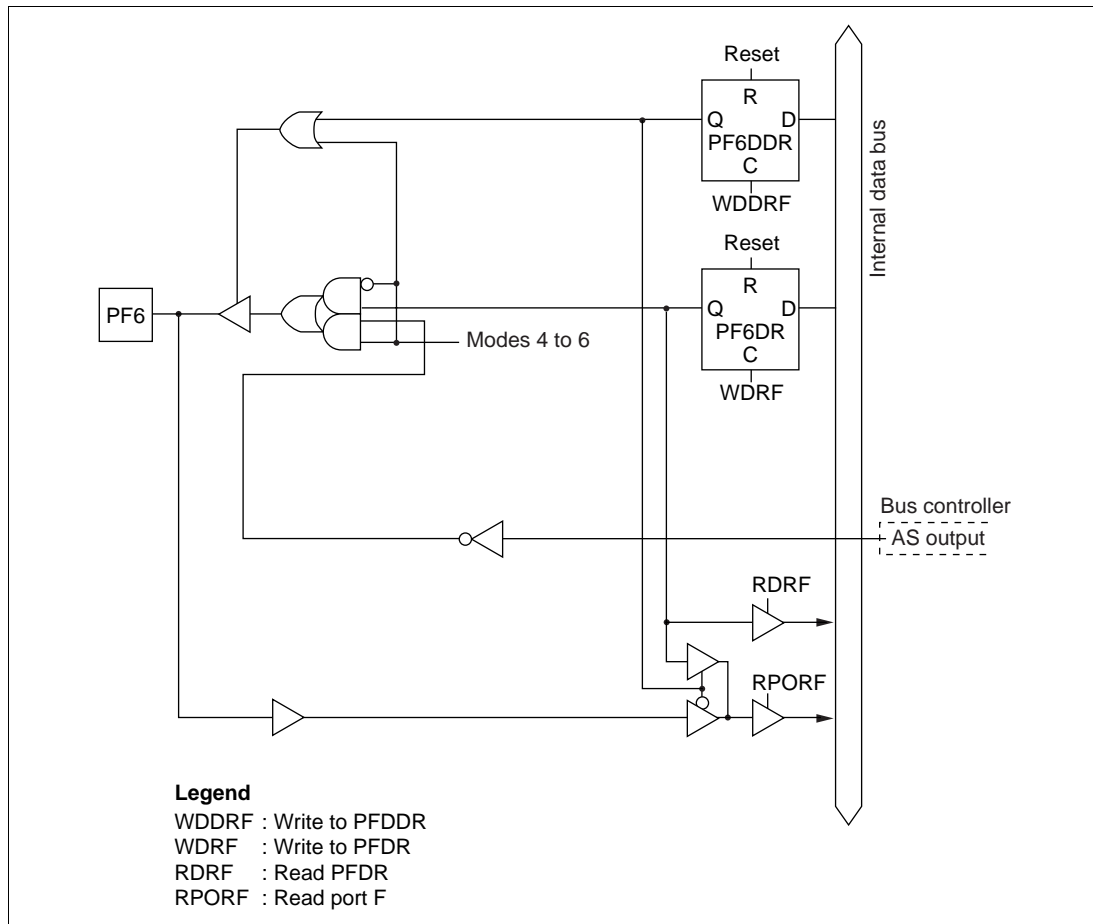
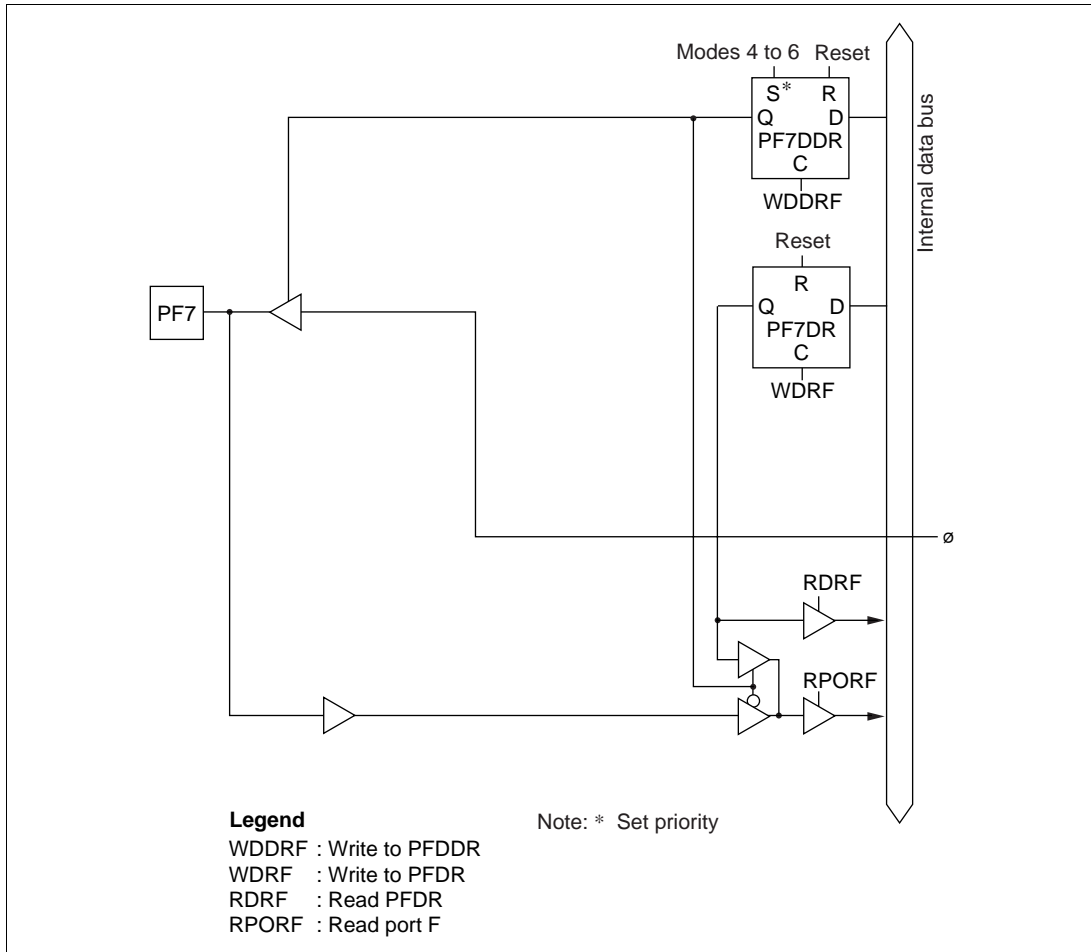


Figure C-23 (f) Port F Block Diagram (Pin PF5)



**Figure C-23 (g) Port F Block Diagram (Pin PF6)**



**Figure C-23 (h) Port F Block Diagram (Pin PF7)**

## C.24 Port G Block Diagram

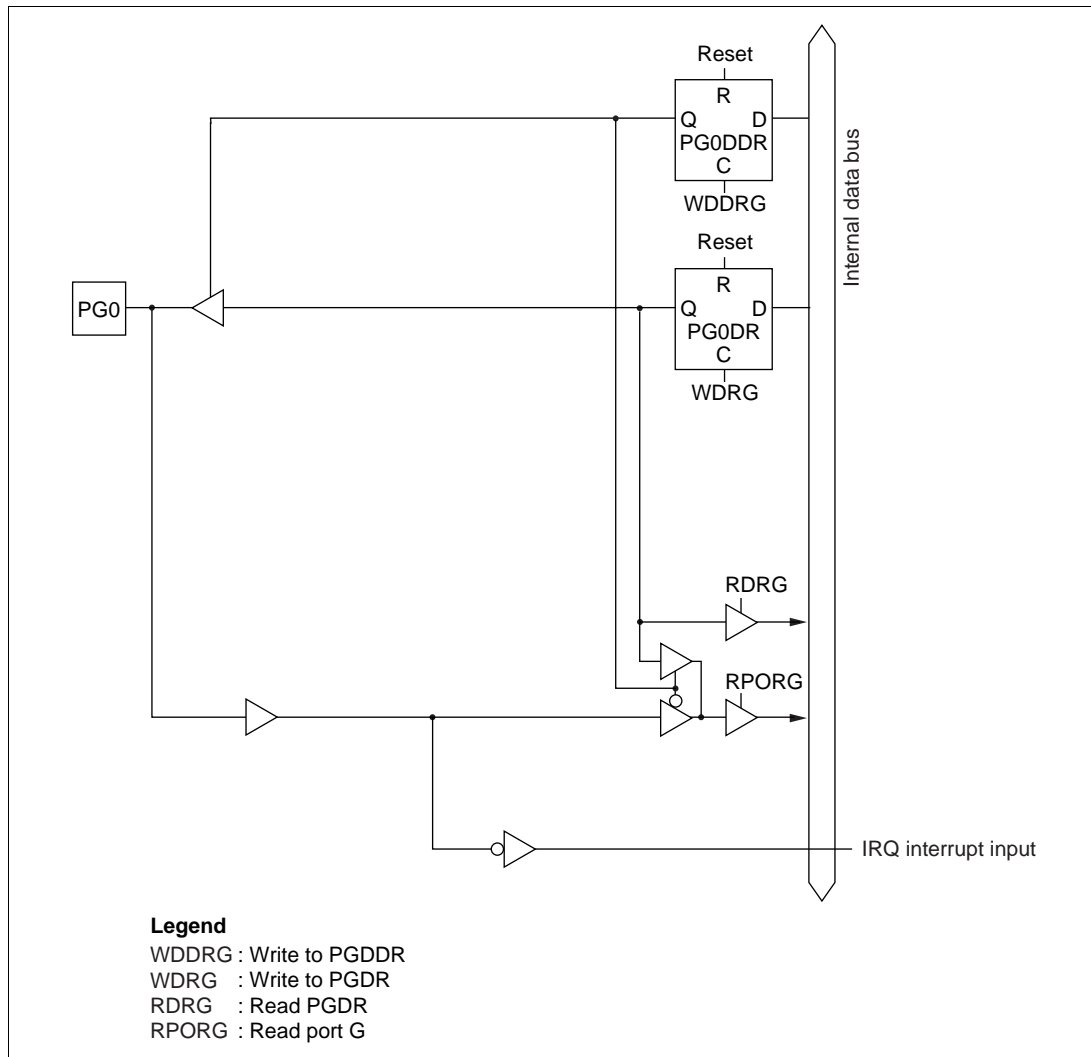


Figure C-24 (a) Port G Block Diagram (Pin PG0)



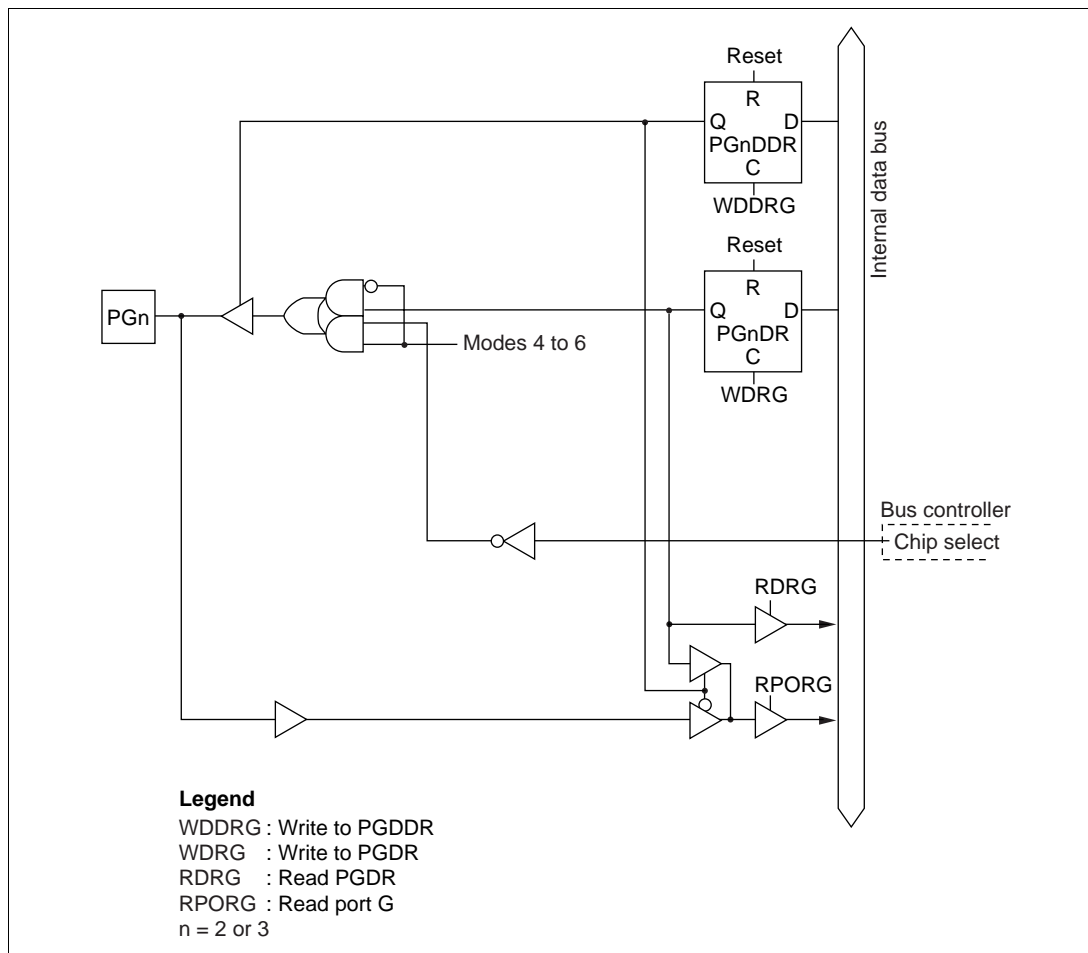
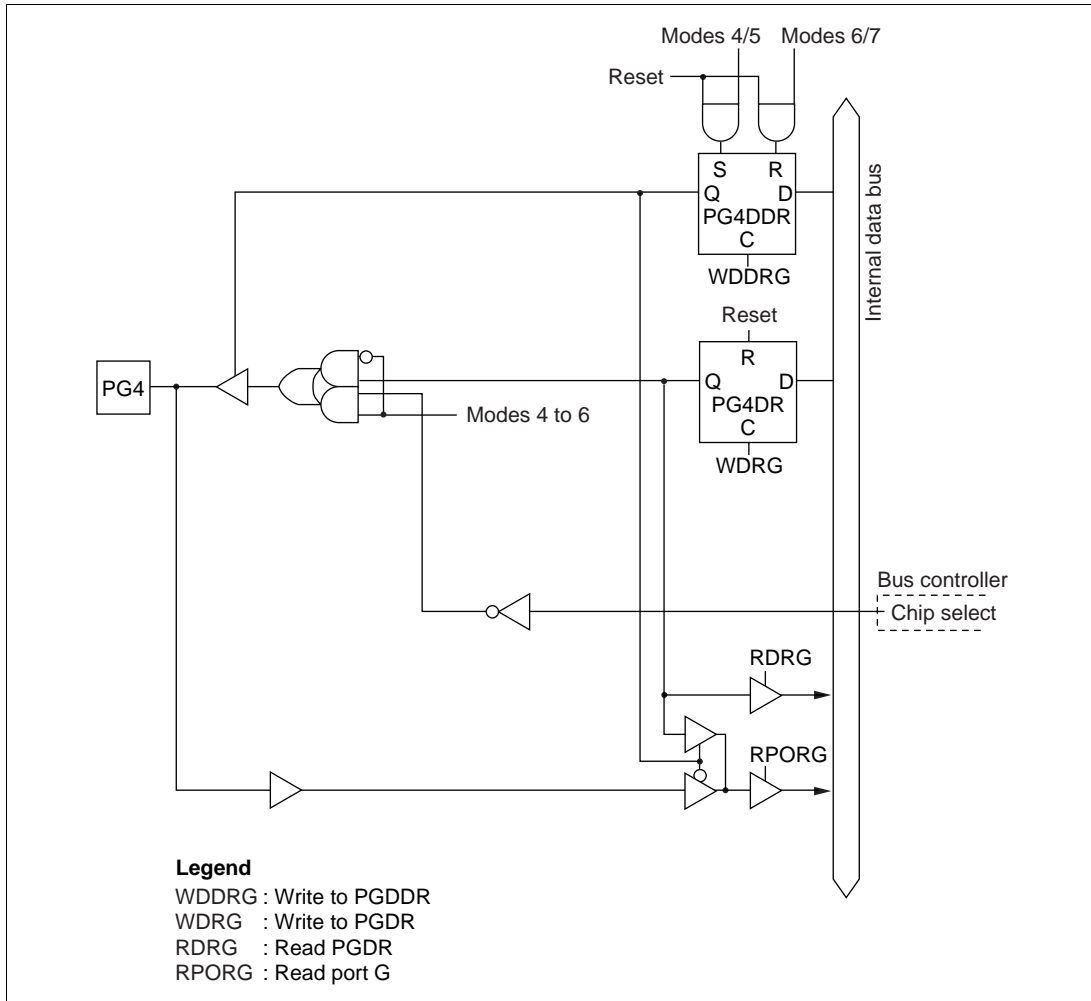


Figure C-24 (c) Port G Block Diagram (Pins PG2 and PG3)



**Figure C-24 (d) Port G Block Diagram (Pin PG4)**



## Appendix D Pin States

### D.1 Port States in Each Mode

Table D-1 lists the I/O port states in each processing mode for the H8S/2633, H8S/2632, H8S/2631, H8S/2633F, and H8S/2633R. Table D-2 lists the I/O port states in each processing mode for the H8S/2695.

**Table D-1 I/O Port States in Each Processing State  
(H8S/2633, H8S/2632, H8S/2631, H8S/2633F, H8S/2633R)**

Port Name Pin Name	MCU Operating Mode	Power- On Reset	Manual Reset	Hardware Standby Mode	Software Standby Mode	Bus Release State	Program Execution State Sleep Mode
Port 1	4 to 7	T	kept	T	kept	kept	I/O port
Port 3	4 to 7	T	kept	T	kept	kept	I/O port
Port 4	4 to 7	T	T	T	T	T	Input port
P73/ $\overline{CS7}$	7	T	kept	T	kept	kept	I/O port
P72/ $\overline{CS6}$ P71/ $\overline{CS5}$ P70/ $\overline{CS4}$	4 to 6	T	kept	T	[DDR · OPE = 0] T [DDR · OPE = 1] H	T	[DDR = 0] Input port [DDR = 1] $\overline{CS7}$ to $\overline{CS4}$
Port 9	4 to 7	T	T	T	T	T	Input port
Port A	4, 5	L	kept	T	[Address output, OPE = 0]	[Address output]	[Address output]
	6	T	kept	T	T [Address output, OPE = 1] kept [Otherwise] kept	[Otherwise] kept	A19 to A17 [Otherwise] I/O port
	7	T	kept	T	kept	kept	I/O port
Port B	4, 5	L	kept	T	[Address output, OPE = 0]	[Address output]	[Address output]
	6	T	kept	T	T [Address output, OPE = 1] kept [Otherwise] kept	[Otherwise] kept	A15 to A8 [Otherwise] I/O port
	7	T	kept	T	kept	kept	I/O port

Port Name Pin Name	MCU Operating Mode	Power- On Reset	Manual Reset	Hardware Standby Mode	Software Standby Mode	Bus Release State	Program Execution State Sleep Mode	
Port C	4, 5	L	kept	T	[OPE = 0] T [OPE = 1] kept	T	A7 to A0	
	6	T	kept	T	[DDR = 1, OPE = 0] T [DDR = 1, OPE = 1] kept [DDR = 0] kept	T	[DDR = 1] A7 to A0 [DDR = 0] I/O port	
	7	T	kept	T	kept	kept	I/O port	
Port D	4 to 6	T	T*	T	T	T	Data bus	
	7	T	kept	T	kept	kept	I/O port	
Port E	4 to 6	8-bit bus	T	kept	T	kept	kept	I/O port
		16-bit bus	T	T*	T	T	T	Data bus
	7	T	kept	T	kept	kept	I/O port	
PF7/ $\emptyset$	4 to 6	Clock output	kept	T	[DDR = 0] T [DDR = 1] H	kept	[DDR = 0] T [DDR = 1] Clock output	
					[DDR = 0] T [DDR = 1] H		[DDR = 0] T [DDR = 1] Clock output	
PF6/ $\overline{\text{AS}}$ $\overline{\text{LCAS}}$	4 to 6	H	H	T	[OPE = 0] T [LCAS output, OPE = 1] $\overline{\text{LCAS}}$ [AS output, OPE = 1] H	T	[LCAS output] $\overline{\text{LCAS}}$ [Otherwise] AS	
					kept		kept	I/O port

Port Name Pin Name	MCU Operating Mode	Power- On Reset	Manual Reset	Hardware Standby Mode	Software Standby Mode	Bus Release State	Program Execution State Sleep Mode
PF5/ $\overline{RD}$ PF4/ $\overline{HWR}$ PF3/ $\overline{LWR}$ / ADTRG/ IRQ3	4 to 6    7	H    T	H    kept	T    T	[OPE = 0] T [OPE = 1] H kept	T    kept	$\overline{RD}$ , $\overline{HWR}$ , $\overline{LWR}$   I/O port
PF2/ $\overline{LCAS}$ / WAIT/ BREQO	4 to 6    7	T    T	[CAS output] H [Otherwise] kept	T    T	[LCAS output, OPE = 0] T [LCAS output, OPE = 1] $\overline{LCAS}$ [Otherwise] kept	[LCAS output] T [BREQOE = 1] BREQO [WAITE = 1] T	[LCAS output] $\overline{LCAS}$ [BREQOE = 1] BREQO [WAITE = 1] WAIT   I/O port
PF1/ $\overline{BACK}$ / BUZZ	4 to 6    7	T    T	kept    kept	T    T	[BRLE = 0, BUZZE = 0] I/O port [BRLE = 0, BUZZE = 1] H [BRLE = 1] H	[BRLE = 0, BUZZE = 0] I/O port [BRLE = 0, BUZZE = 1] H [BRLE = 1] L	[BRLE = 0, BUZZE = 0] I/O port [BRLE = 0, BUZZE = 1] BUZZ [BRLE = 1] $\overline{BACK}$   I/O port
PF0/ $\overline{BREQ}$ / $\overline{IRQ2}$	4 to 6    7	T    T	kept    kept	T    T	[BRLE = 0] kept [BRLE = 1] T	T    kept	[BRLE = 0] I/O port [BRLE = 1] BREQO   I/O port
PG4/ $\overline{CS0}$	4, 5 6   7	H  T  T	kept    kept	T    T	[DDR = 1, OPE = 0] T [DDR = 1, OPE = 1] H [DDR = 0] T	T    kept	[DDR = 0] Input port [DDR = 1] $\overline{CS0}$   I/O port

Port Name Pin Name	MCU Operating Mode	Power- On Reset	Manual Reset	Hardware Standby Mode	Software Standby Mode	Bus Release State	Program Execution State Sleep Mode
PG3/ $\overline{CS1}$ PG2/ $\overline{CS2}$	4 to 6	T	kept	T	[DDR = 1, OPE = 0] T [DDR = 1, OPE = 1] H [DDR = 0] T	T	[DDR = 0] Input port [DDR = 1] $\overline{CS2}$ to $\overline{CS1}$
	7	T	kept	T	kept	kept	I/O port
PG1/ $\overline{CS3}$ / OE/ $\overline{IRQ7}$	4 to 6	T	kept	T	[DDR = 1, OPE = 0] T [DDR = 1, OPE = 1] H [DDR = 0] T	T	[DDR = 0] Input port [OE = 0, DDR = 1] $\overline{CS3}$ [OE = 1, DDR = 1] OE
	7	T	kept	T	kept	kept	I/O port
PG0/ $\overline{CAS}$ / $\overline{IRQ6}$	4 to 6	T	kept	T	[DRAME = 0] kept [DRAME = 1, OPE = 1] $\overline{CAS}$ [DRAME = 1, OPE = 1] T	T	[DRAME = 0] I/O port [DRAME = 1] $\overline{CAS}$
	7	T	kept	T	kept	kept	I/O port

**Legend:**

- H : High level
- L : Low level
- T : High impedance
- kept : Input port becomes high-impedance, output port retains state
- DDR : Data direction register
- OPE : Output port enable
- WAITE : Wait input enable
- BRLE : Bus release enable
- BREQOE : BREQO pin enable
- DRAME : DRAM space setting
- LCASE : DRAM space setting, CW2 = LCASS = 0

Note: \* Indicates the state after completion of the executing bus cycle.

**Table D-2 I/O Port States in Each Processing State (H8S/2695)**

Port Name Pin Name	MCU Operating Mode	Power- On Reset	Manual Reset	Hardware Standby Mode	Software Standby Mode	Bus Release State	Program Execution State Sleep Mode
Port 1	4 to 7	T	kept	T	kept	kept	I/O port
Port 3	4 to 7	T	kept	T	kept	kept	I/O port
Port 4	4 to 7	T	T	T	T	T	Input port
P73/ $\overline{CS7}$	7	T	kept	T	kept	kept	I/O port
P72/ $\overline{CS6}$ P71/ $\overline{CS5}$ P70/ $\overline{CS4}$	4 to 6	T	kept	T	[DDR · OPE = 0] T [DDR · OPE = 1] H	T	[DDR = 0] Input port [DDR = 1] $\overline{CS7}$ to $\overline{CS4}$
Port 9	4 to 7	T	T	T	T	T	Input port
Port A	4, 5	L	kept	T	[Address output, OPE = 0]	[Address output]	[Address output]
	6	T	kept	T	T [Address output, OPE = 1] kept [Otherwise] kept	T [Otherwise] kept	A19 to A17 [Otherwise] I/O port
	7	T	kept	T	kept	kept	I/O port
Port B	4, 5	L	kept	T	[Address output, OPE = 0]	[Address output]	[Address output]
	6	T	kept	T	T [Address output, OPE = 1] kept [Otherwise] kept	T [Otherwise] kept	A15 to A8 [Otherwise] I/O port
	7	T	kept	T	kept	kept	I/O port

Port Name Pin Name	MCU Operating Mode	Power- On Reset	Manual Reset	Hardware Standby Mode	Software Standby Mode	Bus Release State	Program Execution State Sleep Mode	
Port C	4, 5	L	kept	T	[OPE = 0] T [OPE = 1] kept	T	A7 to A0	
	6	T	kept	T	[DDR = 1, OPE = 0] T [DDR = 1, OPE = 1] kept [DDR = 0] kept	T	[DDR = 1] A7 to A0 [DDR = 0] I/O port	
	7	T	kept	T	kept	kept	I/O port	
Port D	4 to 6	T	T*	T	T	T	Data bus	
	7	T	kept	T	kept	kept	I/O port	
Port E	4 to 6	8-bit bus	T	kept	T	kept	kept	I/O port
		16-bit bus	T	T*	T	T	T	Data bus
	7	T	kept	T	kept	kept	I/O port	
PF7/ $\emptyset$	4 to 6	Clock output	kept	T	[DDR = 0] T [DDR = 1] H	kept	[DDR = 0] T [DDR = 1] Clock output	
					[DDR = 0] T [DDR = 1] H		[DDR = 0] T [DDR = 1] Clock output	
PF6/ $\overline{AS}$	4 to 6	H	H	T	[OPE = 0] T [AS output, OPE = 1] H	T	$\overline{AS}$	
					kept		kept	I/O port

Port Name Pin Name	MCU Operating Mode	Power- On Reset	Manual Reset	Hardware Standby Mode	Software Standby Mode	Bus Release State	Program Execution State Sleep Mode
PF5/ $\overline{RD}$ PF4/ $\overline{HWR}$ PF3/ $\overline{LWR}$ / ADTRG/ IRQ3	4 to 6    7	H    T	H    kept	T    T	[OPE = 0] T [OPE = 1] H	T    kept	$\overline{RD}$ , $\overline{HWR}$ , $\overline{LWR}$   I/O port
PF2/ $\overline{WAIT}$ / $\overline{BREQO}$	4 to 6   7	T   T	kept   kept	T   T	kept   kept	[BREQOE = 1] $\overline{BREQO}$ [WAITE = 1] T	[BREQOE = 1] $\overline{BREQO}$ [WAITE = 1] WAIT  I/O port
PF1/ $\overline{BACK}$	4 to 6   7	T   T	kept   kept	T   T	[BRLE = 0] I/O port [BRLE = 1] H	[BRLE = 0] I/O port [BRLE = 1] L	[BRLE = 0] I/O port [BRLE = 1] $\overline{BACK}$  I/O port
PF0/ $\overline{BREQ}$ / $\overline{IRQ2}$	4 to 6   7	T   T	kept   kept	T   T	[BRLE = 0] kept [BRLE = 1] T	T   kept	[BRLE = 0] I/O port [BRLE = 1] $\overline{BREQO}$  I/O port
PG4/ $\overline{CS0}$	4, 5 6  7	H  T	kept	T	[DDR = 1, OPE = 0] T [DDR = 1, OPE = 1] H [DDR = 0] T	T   kept	[DDR = 0] Input port [DDR = 1] $\overline{CS0}$  I/O port

Port Name Pin Name	MCU Operating Mode	Power- On Reset	Manual Reset	Hardware Standby Mode	Software Standby Mode	Bus Release State	Program Execution State Sleep Mode
PG3/ $\overline{CS1}$ PG2/ $\overline{CS2}$	4 to 6	T	kept	T	[DDR = 1, OPE = 0] T [DDR = 1, OPE = 1] H [DDR = 0] T	T	[DDR = 0] Input port [DDR = 1] $\overline{CS2}$ to $\overline{CS1}$
	7	T	kept	T	kept	kept	I/O port
PG1/ $\overline{CS3}$ / $\overline{IRQ7}$	4 to 6	T	kept	T	[DDR = 1, OPE = 0] T [DDR = 1, OPE = 1] H [DDR = 0] T	T	[DDR = 0] Input port [DDR = 1] $\overline{CS3}$
	7	T	kept	T	kept	kept	I/O port
PG0/ $\overline{IRQ6}$	4 to 6	T	kept	T	kept	T	I/O port
	7	T	kept	T	kept	kept	I/O port

**Legend:**

- H : High level
- L : Low level
- T : High impedance
- kept : Input port becomes high-impedance, output port retains state
- DDR : Data direction register
- OPE : Output port enable
- WAITE : Wait input enable
- BRLE : Bus release enable
- BREQOE : BREQO pin enable

Note: \* Indicates the state after completion of the executing bus cycle.



# Appendix E Timing of Transition to and Recovery from Hardware Standby Mode

## Timing of Transition to Hardware Standby Mode

- (1) To retain RAM contents with the RAME bit set to 1 in SYSCR, drive the  $\overline{\text{RES}}$  signal low at least 10 states before the  $\overline{\text{STBY}}$  signal goes low, as shown below.  $\overline{\text{RES}}$  must remain low until  $\overline{\text{STBY}}$  signal goes low (delay from  $\overline{\text{STBY}}$  low to  $\overline{\text{RES}}$  high: 0 ns or more).

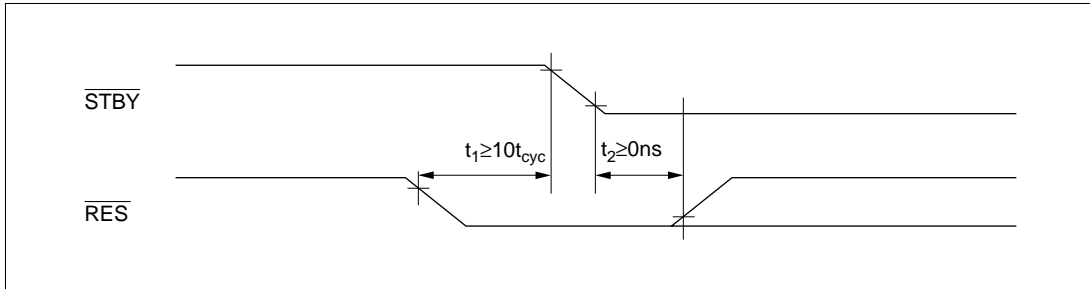


Figure E-1 Timing of Transition to Hardware Standby Mode

- (2) To retain RAM contents with the RAME bit cleared to 0 in SYSCR, or when RAM contents do not need to be retained,  $\overline{\text{RES}}$  does not have to be driven low as in (1).

## Timing of Recovery from Hardware Standby Mode

Drive the  $\overline{\text{RES}}$  signal low and the NMI signal high approximately 100 ns or more before  $\overline{\text{STBY}}$  goes high to execute a power-on reset.

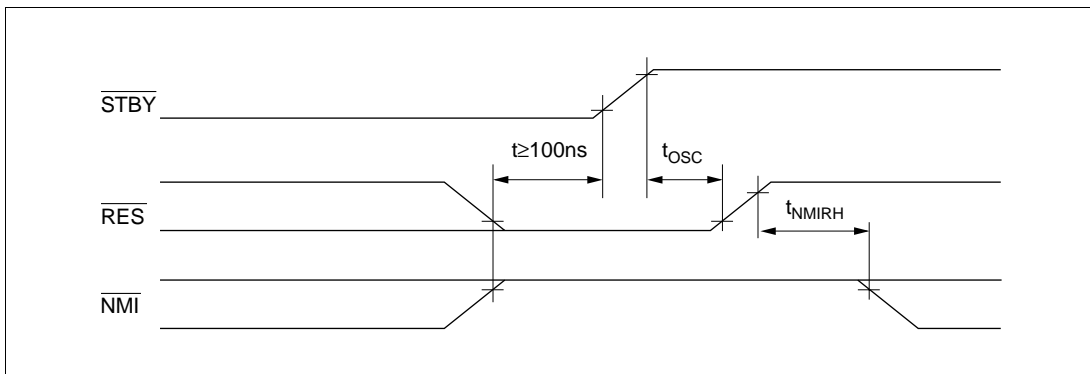


Figure E-2 Timing of Recovery from Hardware Standby Mode

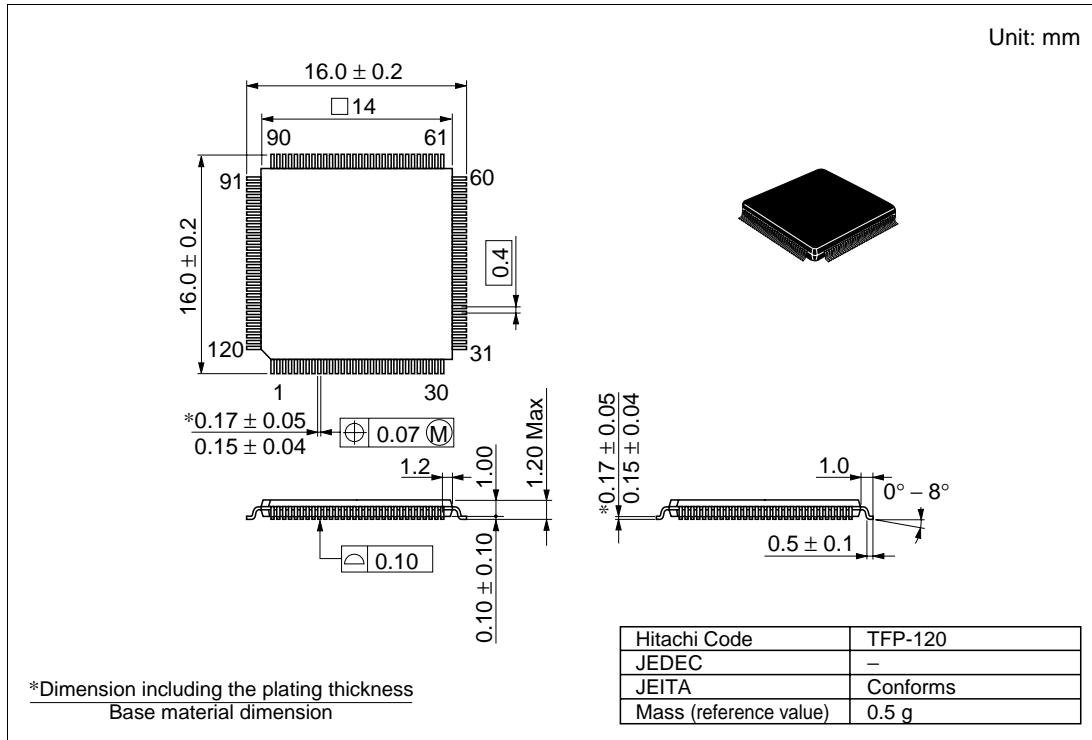
## Appendix F Product Code Lineup

**Table F.1 H8S/2633 Series Product Code Lineup**

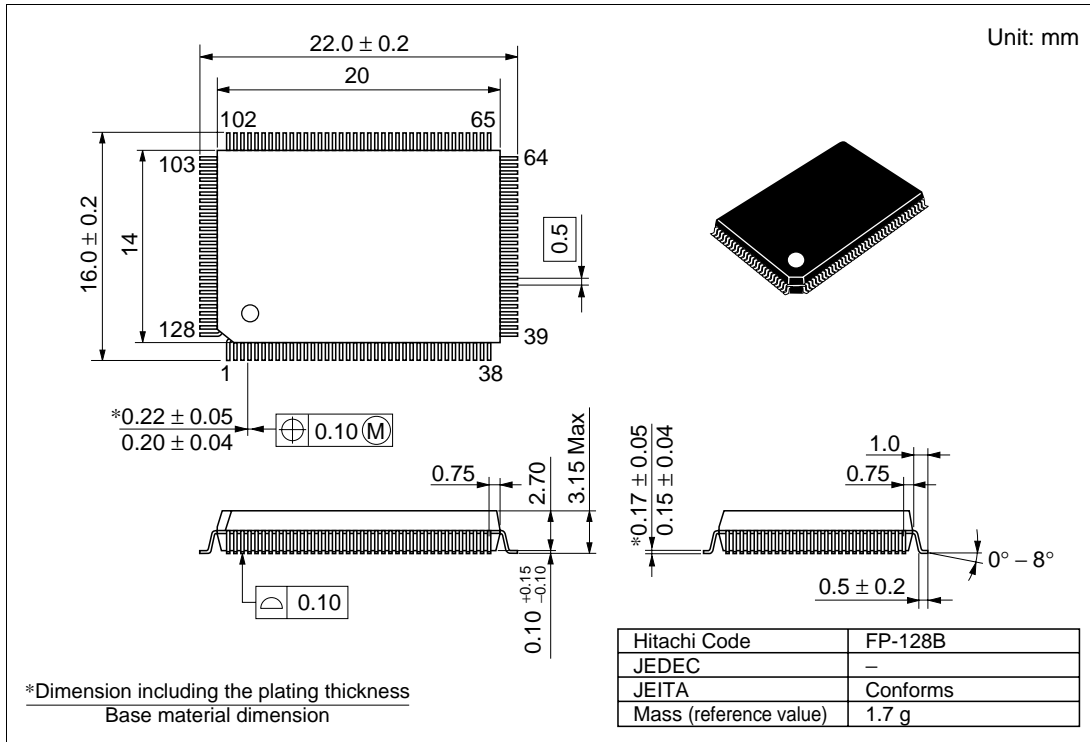
Product Type		Product Code	Mark Code	Package (Hitachi Package Code)
H8S/2633	F-ZTAT™	HD64F2633	HD64F2633F	128-pin QFP (FP-128B)
			HD64F2633TE	120-pin TQFP (TFP-120)
	Mask ROM	HD6432633	HD6432633F	128-pin QFP (FP-128B)
			HD6432633TE	120-pin TQFP (TFP-120)
H8S/2632		HD6432632	HD6432632F	128-pin QFP (FP-128B)
			HD6432632TE	120-pin TQFP (TFP-120)
H8S/2631		HD6432631	HD6432631F	128-pin QFP (FP-128B)
			HD6432631TE	120-pin TQFP (TFP-120)
H8S/2633R	F-ZTAT™	HD64F2633R	HD64F2633RF	128-pin QFP (FP-128B)
			HD64F2633RTE	120-pin TQFP (TFP-120)
H8S/2695	Mask ROM	HD6432695	HD6432695F	128-pin QFP (FP-128B)

## Appendix G Package Dimensions

Figures G-1 and G-2 show the TFP-120 and FP-128 package dimensions of the H8S/2633 Series, H8S/2633F, H8S/2633R, and H8S/2695.



**Figure G-1 TFP-120 Package Dimensions**



**Figure G-2 FP-128B Package Dimensions**

---

**H8S/2633 Series, H8S/2633 F-ZTAT™,  
H8S/2633R F-ZTAT™, H8S/2695 Hardware Manual**

Publication Date: 1st Edition, December 1998  
4th Edition, August 2002

Published by: Business Operation Division  
Semiconductor & Integrated Circuits  
Hitachi, Ltd.

Edited by: Technical Documentation Group  
Hitachi Kodaira Semiconductor Co., Ltd.

Copyright © Hitachi, Ltd., 1998. All rights reserved. Printed in Japan.