

XFHCL6-XXX SERIES INDUCTOR

Mechanical Dimensions:

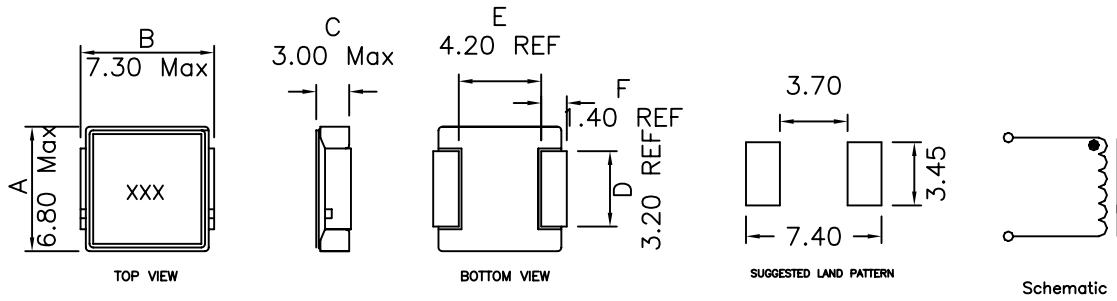

TOLERANCE:
 .xx ±0.25
 Dimensions in MM

Part Number	INDUCTANCE (uH±20%)	RDC (Typ) mOhms	RDC (Max) mOhms	Isat (A)	Irms (A)
XFHCL6-R10M	0.10	1.5	1.7	60.0	32.5
XFHCL6-R15M	0.15	1.9	2.5	52.0	26.0
XFHCL6-R20M	0.20	2.4	3.0	41.0	24.0
XFHCL6-R22M	0.22	2.5	2.8	40.0	23.0
XFHCL6-R33M	0.33	3.5	3.9	30.0	20.0
XFHCL6-R47M	0.47	4.0	4.2	26.0	17.5
XFHCL6-R68M	0.68	5.0	5.5	25.0	15.5
XFHCL6-R82M	0.82	6.7	8.0	24.0	13.0
XFHCL6-1R0M	1.00	9.0	10.0	22.0	11.0
XFHCL6-1R5M	1.50	14.0	15.0	18.0	9.0
XFHCL6-2R2M	2.20	18.0	20.0	14.0	8.0
XFHCL6-3R3M	3.30	28.0	30.0	13.5	6.0
XFHCL6-4R7M	4.70	37.0	40.0	10.0	5.5
XFHCL6-6R8M	6.80	54.0	60.0	8.0	4.5
XFHCL6-8R2M	8.20	64.0	68.0	7.5	4.0
XFHCL6-100M	10.00	102.0	105.0	7.0	3.0

Notes:

1. Measurement frequency of Inductance value: at 100KHz, 0.25V
2. Measurement ambient temperature of L, DCR and IDC: at 25°C
3. Isat: DC current at which the inductance drops 20%(typ) from its value without current
4. Irms: Average current for 40°C temperature rise from 25°C ambient(typ)
5. Inductance tolerance: M:±20%
6. Solderability: Leads shall meet MIL-STD-202G, Method 208H for solderability.
7. Flammability: UL94V-0
8. ASTM oxygen index: > 28%
9. Insulation System: Class F 155°C. UL file E151556
10. Operating Temperature Range: All listed parameters are to be within tolerance from -55°C to +125°C
11. Storage Temperature Range: -55°C to +125°C
12. Aqueous wash compatible
13. SMD Lead Coplanarity: ±0.004"(0.102mm)
14. Electrical and mechanical specifications 100% tested
15. RoHS Compliant Component
16. Packaging: Taping: 1000 Piece/reel

XFHCL6-XXX SERIES INDUCTOR

Mechanical Dimensions:

XFHCL6-R10M

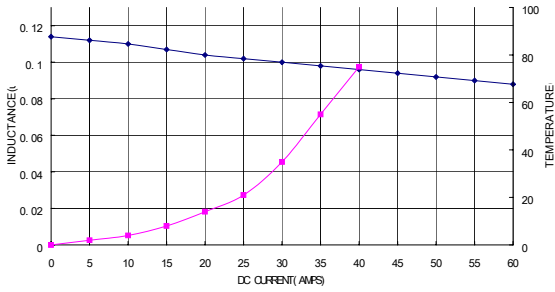

XFHCL6-R15M

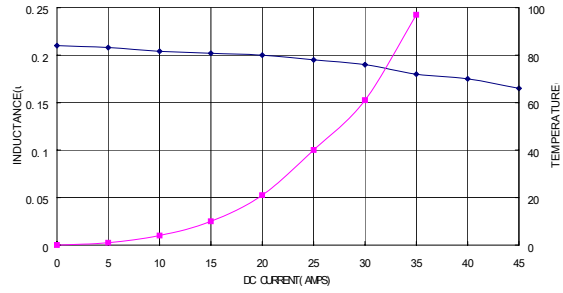

XFHCL6-R20M

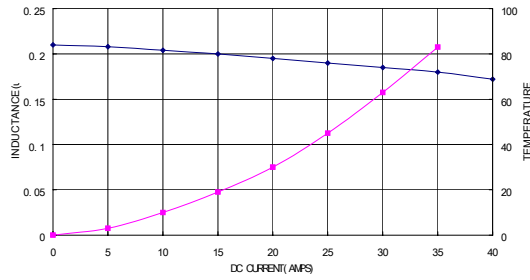

XFHCL6-R22M

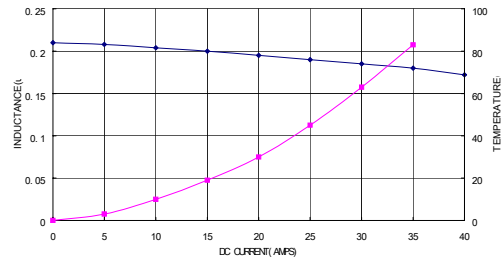

XFHCL6-R33M

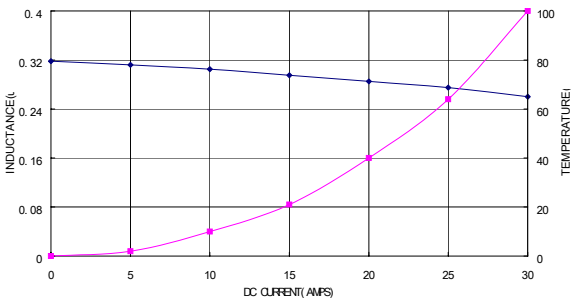

XFHCL6-R47M

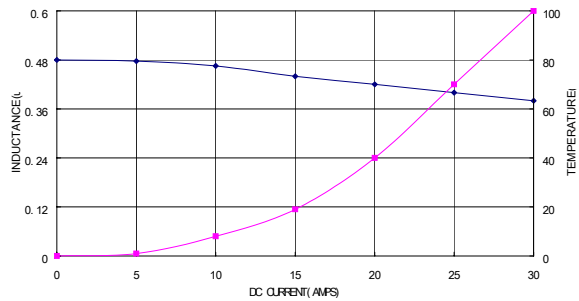

XFHCL6-R68M

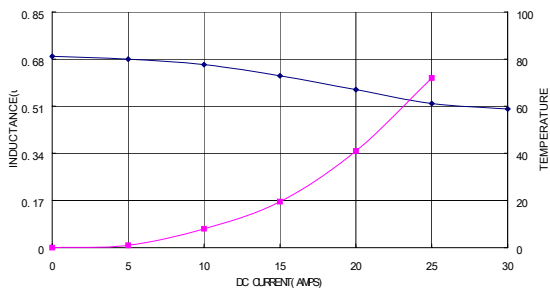

XFHCL6-R82M

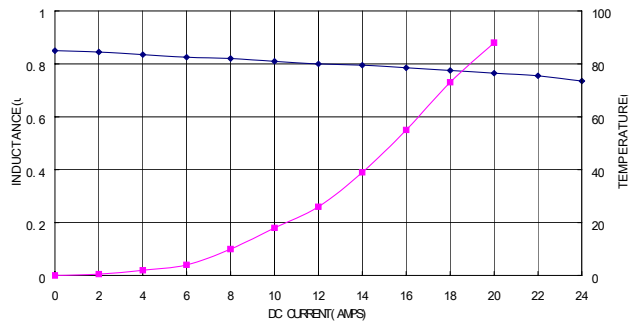

XFHCL6-XXX SERIES INDUCTOR

Mechanical Dimensions:

XFHCL6-1R0M

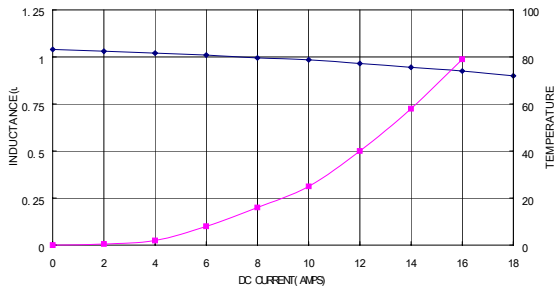

XFHCL6-1R5M

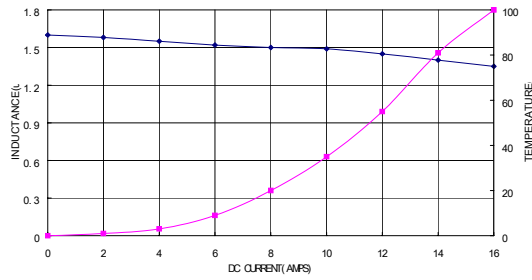

XFHCL6-2R2M

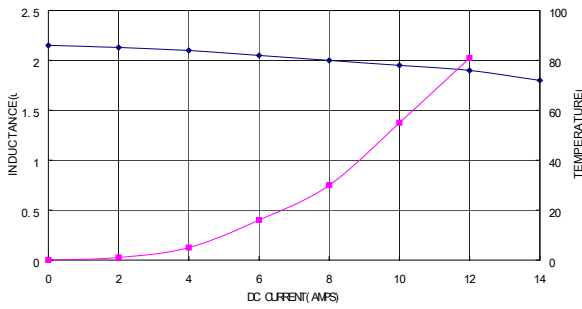

XFHCL6-3R3M

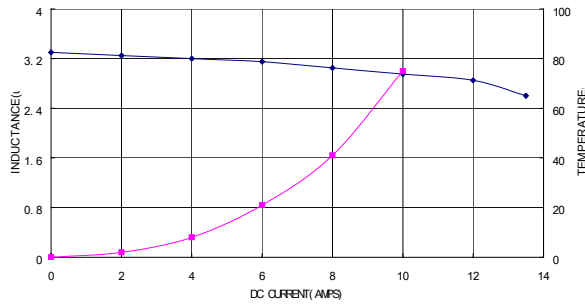

XFHCL6-4R7M

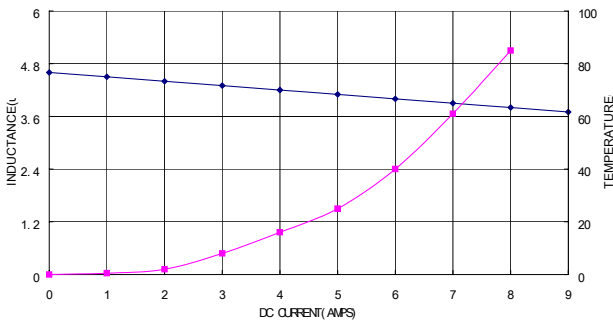

XFHCL6-6R8M

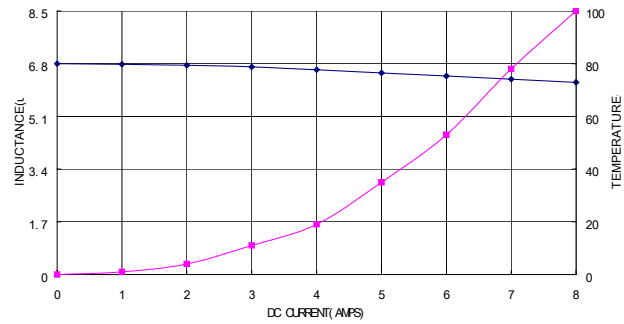

XFHCL6-8R2M

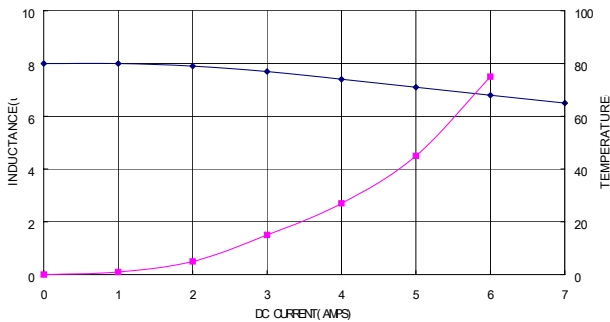

XFHCL6-100M

