



LC723481W,723482W,723483W

Low-Voltage ETR-Controller

Overview

The LC723481W, 723482W, and 723483W are low-voltage electronic tuning radio microcontrollers that include a PLL that operates up to 250 MHz and a 1/4 duty 1/2 bias LCD driver on chip. These ICs include an on-chip DC-DC converter, making it is easy to create the supply voltages required for tuning and allowing cost reductions in end products.

These ICs are optimal for use in low-voltage portable audio equipment that includes a radio receiver.

Function

- Program memory (ROM):
 - 2048 × 16 bits (4K bytes) LC723481W
 - 3072 × 16 bits (6K bytes) LC723482W
 - 4096 × 16 bits (8K bytes) LC723483W
- Data memory (RAM):
 - 128 × 4 bits LC723481W
 - 192 × 4 bits LC723482W
 - 256 × 4 bits LC723483W
- Cycle time: 40 μs (all 1-word instructions) at 75kHz crystal oscillation
- Stack: 4 levels (8 levels)
LC723481W(LC723482W/3W)
- LCD driver: 48 to 80 segments (1/4 duty, 1/2 bias drive)
- Interrupts: One external interrupt
Timer interrupts (1, 5, 10, and 50 ms)
- A/D converter: Three input channels
(5-bit successive approximation conversion)
- Input ports: 7 ports (of which 3 can be switched for use as A/D converter inputs)
- Output ports: 6 ports (of which 1 can be switched for use as the beep tone output and 2 are open-drain ports)

Continued on next page.

Package Dimensions

unit: mm

3190A-SQFP64

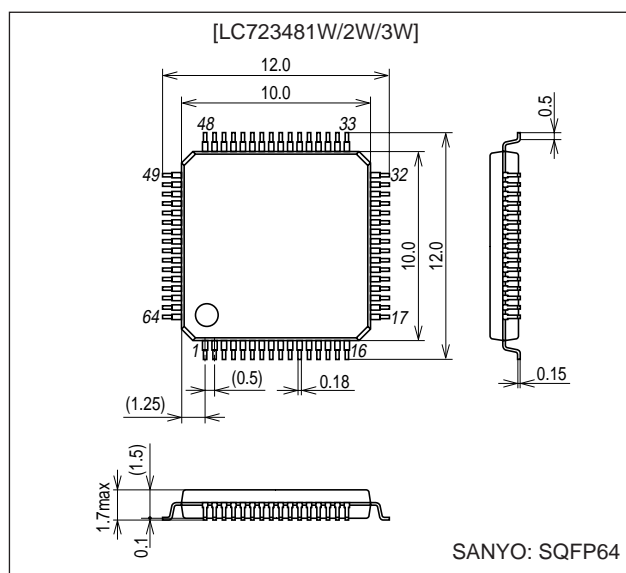

■ Any and all SANYO products described or contained herein do not have specifications that can handle applications that require extremely high levels of reliability, such as life-support systems, aircraft's control systems, or other applications whose failure can be reasonably expected to result in serious physical and/or material damage. Consult with your SANYO representative nearest you before using any SANYO products described or contained herein in such applications.

■ SANYO assumes no responsibility for equipment failures that result from using products at values that exceed, even momentarily, rated values (such as maximum ratings, operating condition ranges, or other parameters) listed in products specifications of any and all SANYO products described or contained herein.

SANYO Electric Co.,Ltd. Semiconductor Company

TOKYO OFFICE Tokyo Bldg., 1-10, 1 Chome, Ueno, Taito-ku, TOKYO, 110-8534 JAPAN

LC723481W/2W/3W

Continued from preceding page.

I/O ports: 16 pins (Of these 8 can be switched over to function as LCD ports as a mask options.)

- PLL: Dead band control is supported. (Four types)
Reference frequencies: 1, 3, 3.125, 5, 6.25, 12.5, and 25 kHz
- Input frequencies: FM band: 10 to 250 MHz
AM band: 0.5 to 40 MHz
- Input sensitivity:
FM band: 35 mVrms (50 mVrms at 130 MHz or higher frequency)
AM band: 35 mVrms
- IF counting: Using the HCTR input pin for 0.4 to 12 MHz signals
- External reset input: During CPU and PLL operations, instruction execution is started from location 0.
- Built-in power-on reset circuit:
The CPU starts execution from location 0 when power is first applied.
- Halt mode: The controller-operating clock is stopped.
- Backup mode: The crystal oscillator is stopped.
- Static power-on function: Backup state is cleared with the PF port

- Beep tone: 1.5625 and 3.125 kHz
- Built-in low-pass filter amplifier: This circuit obviates the need for an external amplifier for the PLL circuit and contributes to reduced end product costs.
- Built-in DC/DC converter:
Cost reduced in tuner-use power supply circuit
- Memory retention voltage: 0.9 V at least
- V_{DD} voltage
 - PLL: 1.8 to 3.6 V
 - CPU: 1.4 to 3.6 V
 - ADC: 1.6 to 3.6 V
- Optional function switches:
 - PH0 to PH3/S13 to S16
 - PG0 to PG3/S17 to S20
 - PG0 to PG3 (open-drain output/general-purpose output)
 - PH0 to PH3 (open-drain output/general-purpose output)
 - FM DC/DC clock (75 kHz or 1/256 times the local FM oscillator frequency)
 - AM DC/DC clock (1/2, 1/4, 1/8, or 1/16 times the AM local oscillator frequency)
- Package: SQFP-64 (0.5-mm pitch)

Pin Assignment

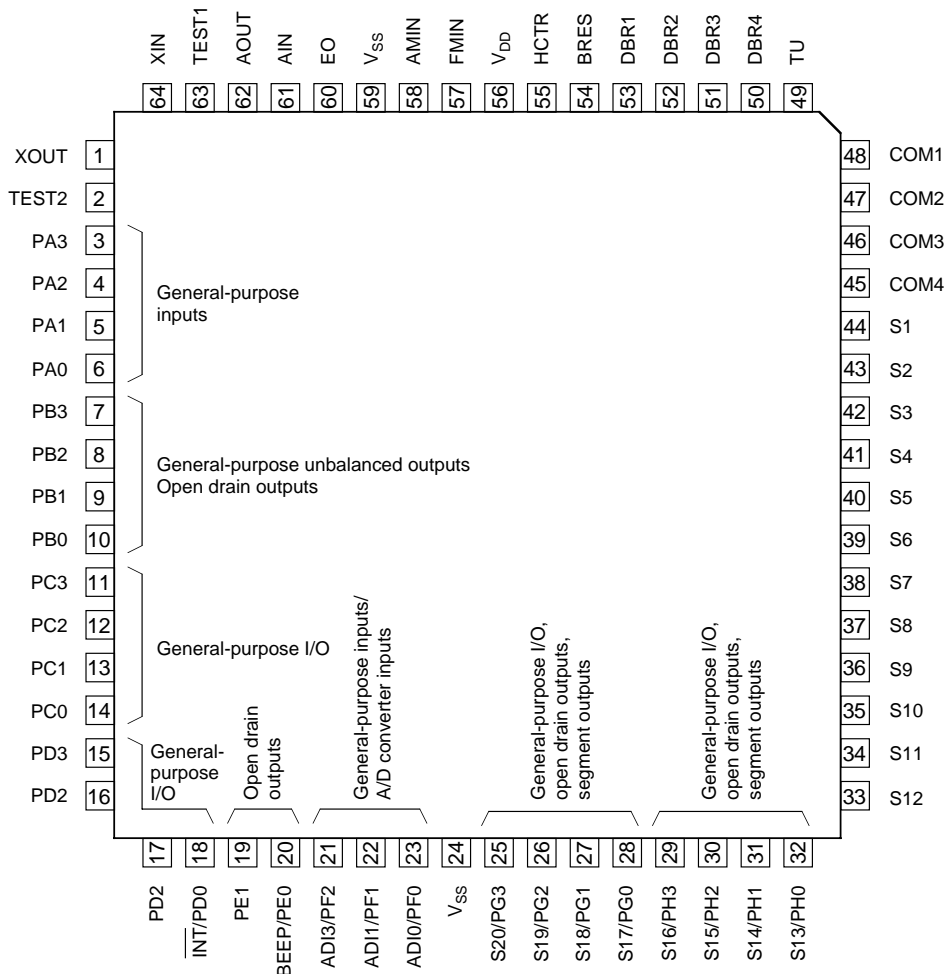

LC723481W/2W/3W

Specifications

Absolute Maximum Ratings at $T_a = 25^\circ\text{C}$, $V_{SS} = 0\text{ V}$

Parameter	Symbol	Conditions	Ratings	Unit
Maximum supply voltage	$V_{DD\text{ max}}$		-0.3 to +4.0	V
Input voltage	V_{IN}	All input pins	-0.3 to $V_{DD} + 0.3$	V
Output voltage	$V_{OUT(1)}$	AOUT, PE, TU	-0.3 to +15	V
	$V_{OUT(2)}$	All output pins except $V_{OUT(1)}$	-0.3 to $V_{DD} + 0.3$	V
Output current	$I_{OUT(1)}$	PC, PD, PG, PH, EO	0 to 3	mA
	$I_{OUT(2)}$	PB	0 to 1	mA
	$I_{OUT(3)}$	AOUT, PE, TU	0 to 2	mA
	$I_{OUT(4)}$	S1 to S20	300	μA
	$I_{OUT(5)}$	COM1 to COM4	3	mA
Allowable power dissipation	P_{dmax}	$T_a = -20$ to $+70^\circ\text{C}$	300	mW
Operating temperature	T_{opr}		-20 to +70	$^\circ\text{C}$
Storage temperature	T_{stg}		-45 to +125	$^\circ\text{C}$

Allowable Operating Ranges at $T_a = -20$ to $+70^\circ\text{C}$, $V_{DD} = 1.8$ to 3.6 V

Parameter	Symbol	Conditions	Ratings			Unit
			min	typ	max	
Supply voltage	$V_{DD(1)}$	PLL operating voltage	1.8	3.0	3.6	V
	$V_{DD(2)}$	Memory retention voltage	1.0			
	$V_{DD(3)}$	CPU operating voltage	1.4	3.0	3.6	
	$V_{DD(4)}$	A/D converter operating voltage	1.6	3.0	3.6	
Input high-level voltage	$V_{IH(1)}$	Input ports other than $V_{IH(2)}$, $V_{IH(3)}$, AMIN, FMIN, HCTR, and XIN	$0.7 V_{DD}$		V_{DD}	V
	$V_{IH(2)}$	BRES port	$0.8 V_{DD}$		V_{DD}	V
	$V_{IH(3)}$	Port PF	$0.6 V_{DD}$		V_{DD}	V
Input low-level voltage	$V_{IL(1)}$	Input ports other than $V_{IL(2)}$, $V_{IL(3)}$, AMIN, FMIN, HCTR, and XIN	0		$0.3 V_{DD}$	V
	$V_{IL(2)}$	BRES port	0		$0.2 V_{DD}$	V
	$V_{IL(3)}$	Port PF	0		$0.2 V_{DD}$	V
Input amplitude	$V_{IN(1)}$	XIN	0.5		0.6	Vrms
	$V_{IN(2)}$	FMIN, AMIN	0.035		0.35	Vrms
	$V_{IN(3)}$	FMIN	0.05		0.35	Vrms
	$V_{IN(4)}$	HCTR	0.035		0.35	Vrms
Input voltage range	$V_{IN(5)}$	ADIO, ADI1, ADI3	0		V_{DD}	V
Input frequency	$F_{IN(1)}$	XIN: $C_I \leq 35\text{ k}\Omega$	70	75	80	kHz
	$F_{IN(2)}$	FMIN: $V_{IN(2)}$, $V_{DD(1)}$	10		130	MHz
	$F_{IN(3)}$	FMIN: $V_{IN(3)}$, $V_{DD(1)}$	130		250	MHz
	$F_{IN(4)}$	AMIN(H): $V_{IN(2)}$, $V_{DD(1)}$	2		40	MHz
	$F_{IN(5)}$	AMIN(L): $V_{IN(2)}$, $V_{DD(1)}$	0.5		10	MHz
	$F_{IN(6)}$	HCTR: $V_{IN(4)}$, $V_{DD(1)}$	0.4		12	MHz

LC723481W/2W/3W

Electrical Characteristics within the allowable operating ranges

Parameter	Symbol	Conditions	Ratings			Unit
			min	typ	max	
Input high-level current	I _{IH} (1)	XIN: V _I = V _{DD} = 3.0 V			3	μA
	I _{IH} (2)	FMIN, AMIN, HCTR: V _I = V _{DD} = 3.0 V	3	8	20	μA
	I _{IH} (3)	PA/PF (without pull-down resistors), the PC, PD, PG, PH, ports, and BRES: V _I = V _{DD} = 3.0 V			3	μA
Input low-level current	I _{IL} (1)	XIN: V _{DD} = V _{SS}			-3	μA
	I _{IL} (2)	FMIN, AMIN, HCTR: V _I = V _{DD} = V _{SS}	-3	-8	-20	μA
	I _{IL} (3)	PA/PF (without pull-down resistors), the PC, PD, PG, PH, ports, and BRES: V _I = V _{DD} = V _{SS}			-3	μA
Input floating voltage	V _{IF}	PA/PF (with pull-down resistors)			0.05 V _{DD}	V
Pull-down resistor values	R _{PD} (1)	PA/PF (with pull-down resistors), V _{DD} = 3.0 V	75	100	200	kΩ
	R _{PD} (2)	TEST1, TEST2		10		kΩ
Hysteresis	V _H	BRES	0.1 V _{DD}	0.2 V _{DD}		V
Voltage doubler reference voltage	DBR4	Referenced to V _{DD} , C(3) = 0.47 μF, Ta = 25°C *1	1.3	1.5	1.7	V
Voltage doubler step-up voltage	DBR1, 2, 3	C(1) = 0.47 μF C(2) = 0.47 μF, without loading, Ta = 25°C *1	2.7	3.0	3.3	V
Output high-level voltage	V _{OH} (1)	PB: I _O = -1 mA	V _{DD} - 0.7 V _{DD}		V _{DD} - 0.3 V _{DD}	V
	V _{OH} (2)	PC, PD, PG, PH, : I _O = -1 mA	V _{DD} - 0.3 V _{DD}			V
	V _{OH} (3)	EO: I _O = -500 μA	V _{DD} - 0.3 V _{DD}			V
	V _{OH} (4)	XOUT: I _O = 200 μA	V _{DD} - 0.3 V _{DD}			V
	V _{OH} (5)	S1 to S20: I _O = -20 μA *1	2.0			V
	V _{OH} (6)	COM1, COM2, COM3, COM4: I _O = -100 μA *1	2.0			V
Output low-level voltage	V _{OL} (1)	PB: I _O = -50 μA	0.3 V _{DD}		0.7 V _{DD}	V
	V _{OL} (2)	PC, PD, PG, PH, PE: I _O = -1 mA			0.3 V _{DD}	V
	V _{OL} (3)	EO: I _O = -500 μA			0.3 V _{DD}	V
	V _{OL} (4)	XOUT: I _O = -200 μA			0.3 V _{DD}	V
	V _{OL} (5)	S1 to S20: I _O = -20 μA *1			1.0	V
	V _{OL} (6)	COM1, COM2, COM3, COM4: I _O = -100 μA *1			1.0	V
	V _{OL} (7)	PE: I _O = 2 mA			1.0	V
	V _{OL} (8)	AOUT (AIN = 1.3 V), TU: I _O = 1 mA, V _{DD} = 3 V			0.5	V
Output off leakage current	I _{OFF} (1)	Ports PB, PC, PD, PG, PH and EO	-3		+3	μA
	I _{OFF} (2)	AOUT, PE and port TU	-100		+100	nA
A/D converter error		ADI0, ADI1, ADI3, V _{DD} (4)	-1/2		+1/2	LSB
Current drain	I _{DD} (1)	V _{DD} (1): F _{IN} (2) 130 MHz, Ta = 25°C		5		mA
	I _{DD} (2)	V _{DD} (2): In HALT mode, Ta = 25°C *2		0.1		mA
	I _{DD} (3)	V _{DD} = 3.6 V, with the oscillator stopped, Ta = 25°C *3		1		μA
	I _{DD} (4)	V _{DD} = 1.8 V, with the oscillator stopped, Ta = 25°C *3		0.5		μA

Note: The halt mode current is due to the CPU executing 20 instruction steps every 125 ms.

Note: * C(1), C(2), and C(3) must be connected even if an LCD is not used.

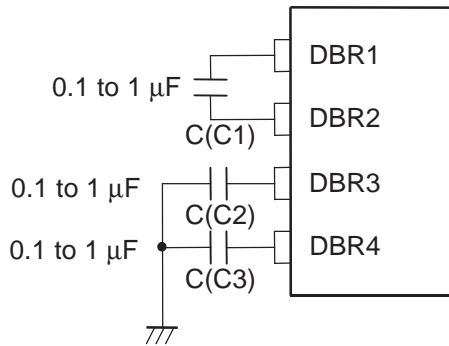

Notes: *1. The capacitors C(1), C(2), and C(3) must be connected to the DBR pins.

*2. Halt mode current measurement circuit

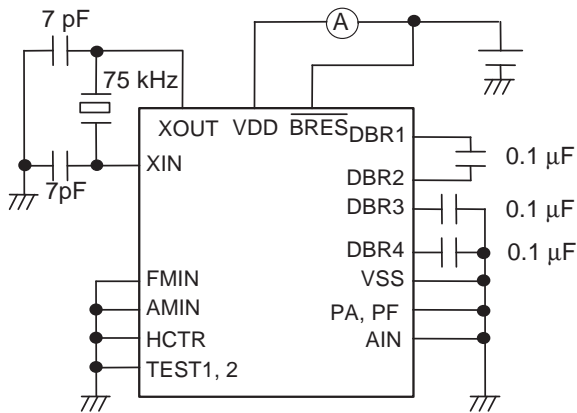

*3. Backup mode current measurement circuit

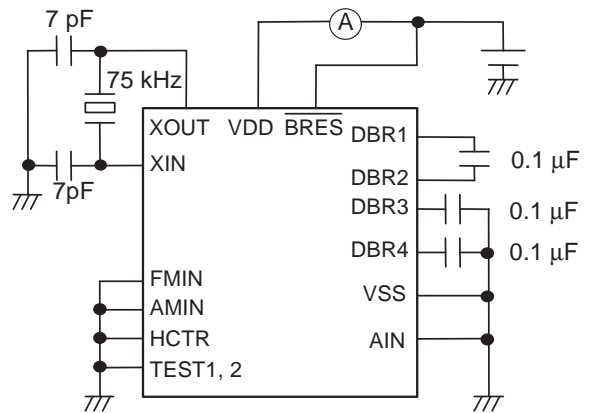

With all ports other than those specified above left open.
 With output mode selected for PC and PD.
 With segments S13 to S20 selected.

With all ports other than those specified above left open.
 With output mode selected for PC and PD.
 With segments S13 to S20 selected.

LC723481W/2W/3W

Block Diagram

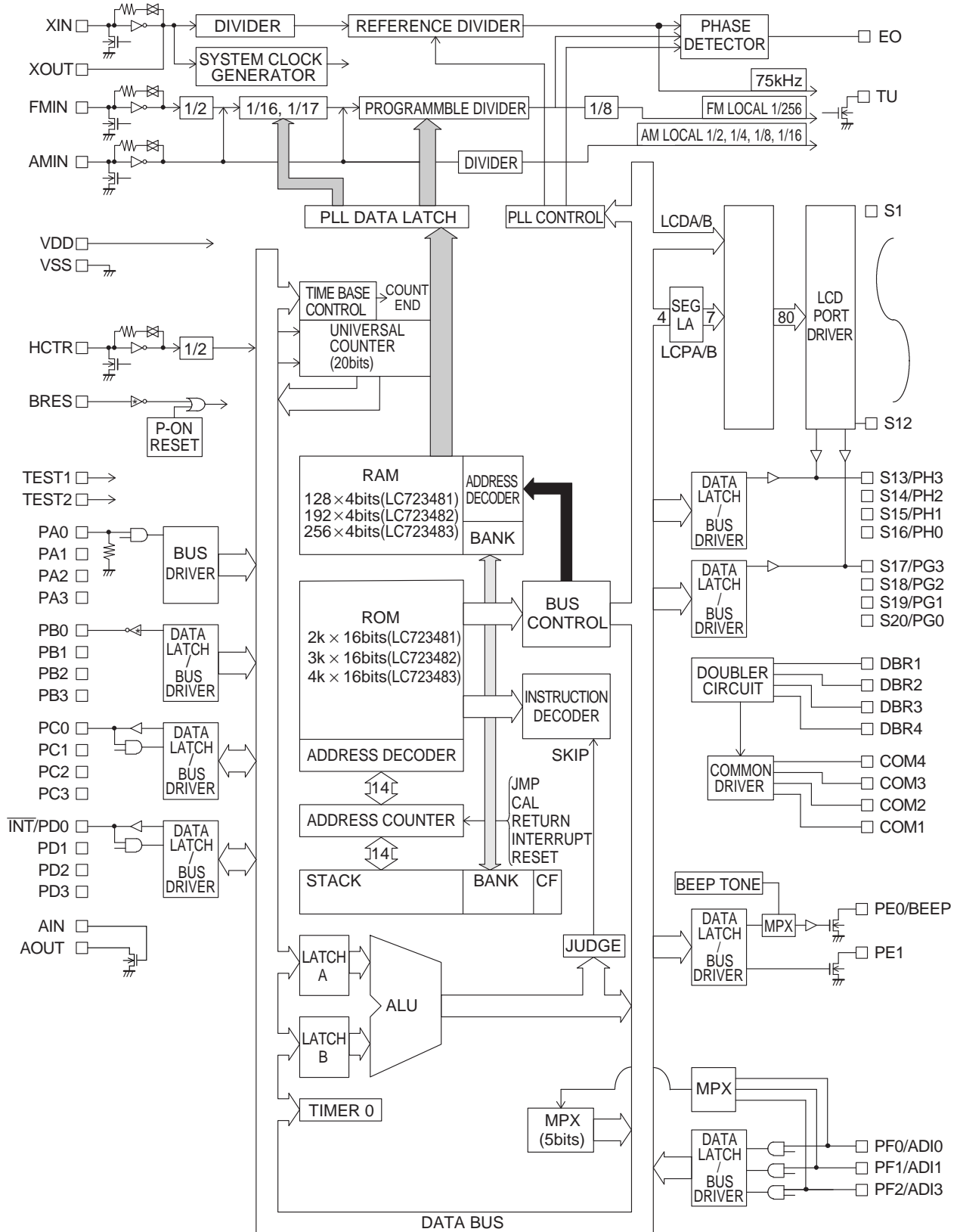

LC723481W/2W/3W

Pin Functions

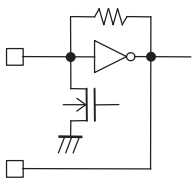
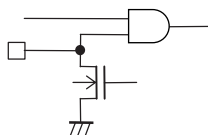
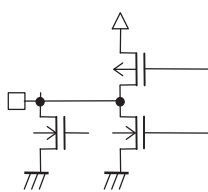
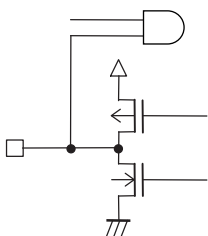
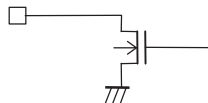
Pin No.	Pin	I/O	Function	I/O circuit
64 1	XIN XOUT	I O	75 kHz oscillator connections	
63 2	TEST1 TEST2	I I	IC testing. These pins must be connected to ground during normal operation.	—
6 5 4 3	PA0 PA1 PA2 PA3	I	Special-purpose key return signal input ports designed with a low threshold voltage. When used in conjunction with port PB to form a key matrix, up to 3 simultaneous key presses can be detected. The four pull-down resistors are selected together in a single operation using the IOS instruction (PwN = 2, b1); they cannot be specified individually. Input is disabled in backup mode, and the pull-down resistors are disabled after a reset.	Input with built-in pull-down resistor 
10 9 8 7	PB0 PB1 PB2 PB3	O	General-purpose CMOS and n-channel open-drain output shared-function ports. The IOS instruction (PwN = 2) is used for function switching. (b0: PB0, b2: PB1, b3: PB2, PB3) (0: general-purpose CMOS, 1: n-channel open-drain) Special-purpose key source signal output ports. Since unbalanced CMOS output transistor circuits are used, diodes to prevent short-circuits when multiple keys are pressed are not required. These ports go to the output high-impedance state in backup mode. These ports go to the output high-impedance state after a reset and remain in that state until an output instruction (OUT, SPB, or RPB) is executed. *: Verify the output impedance conditions carefully if these pins are used for functions other than key source outputs.	Unbalanced CMOS push-pull 
14 13 12 11 18 17 16 15	PC0 PC1 PC2 PC3 INT0/PD0 PD1 PD2 PD3 *2	I/O	General-purpose I/O ports. PD0 can be used as an external interrupt port. Input or output mode can be set individually using the IOS instruction (PwN = 4, 5) by the bit . A value of 0 specifies input, and 1 specifies output. These ports go to the input disabled high-impedance state in backup mode. They are set to function as general-purpose input ports after a reset.	CMOS push-pull 
20 19	BEEP/PE0 PE1	O	General-purpose output and BEEP output (PE0 shared function ports). The BEEP instruction is used to switch the BEEP/PE0 port between the general-purpose output port and the BEEP output functions. A BEEP instruction with b2 = 0 will set the BEEP/PE0 port to function as a general-purpose output port. If b2 is set to 1, the instruction will select the BEEP output function. Bits b0 and b1 switch the frequency of the BEEP output. This IC supports two BEEP frequencies. *: When the PE0 port is set to function as the BEEP output, executing an output instruction for PE0 will only change the value of the internal output latch; it will have no effect on the output. Only the PE0 pin can be switched between the general-purpose output port and BEEP output functions; the PE1 pin is a dedicated general-purpose output port. In backup mode, these ports go to the high-impedance state. These ports will remain in that state until either an output instruction or a BEEP instruction is executed. Since these ports are open drain ports, a resistor must be inserted between each port and VDD. At reset, they are set to the general-purpose output port function.	N-channel open-drain 

Continued on next page.

LC723481W/2W/3W

Continued from preceding page.

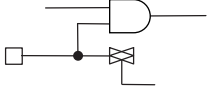
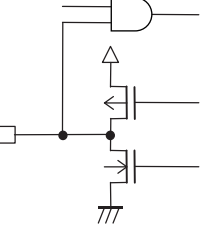
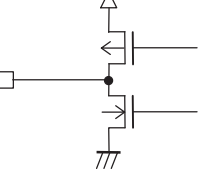
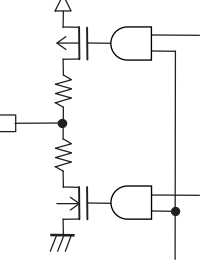
Pin No.	Pin	I/O	Function	I/O circuit												
23 22 21	PF0/ADI0 PF1/ADI1 PF2/ADI3	I	<p>General-purpose input and A/D converter input shared function ports. The IOS instruction (Pwn = FH) is used to switch between the general-purpose input and A/D converter port functions. The general-purpose input and A/D converter port functions can be switched by the bit, with 0 specifying general-purpose input, and 1 specifying the A/D converter input function. To select the A/D converter function, set up the A/D converter pin with an IOS instruction with Pwn set to 1. The A/D converter is started with the UCC instruction (b3 = 1, b2 = 1). The ADCE flag is set when the conversion completes. The INR instruction is used to read in the data.</p> <p>*: If an input instruction is executed for one of these pins which is set up for analog input, the read in data will be at the low level since CMOS input is disabled. In backup mode these pins go to the input disabled high-impedance state. These ports are set to their general-purpose input port function after a reset. The A/D converter is a 5-bit successive approximation type converter, and features a conversion time of 1.28 ms. Note that the full-scale A/D converter voltage (1FH) is (62/96) V_{DD}.</p>	<p>CMOS input/analog input</p> 												
25 26 27 28 29 30 31 32	PG3/S20 PG2/S19 PG1/S18 PG0/S17 PH3/S16 PH2/S15 PH1/S14 PH0/S13 *2	O	<p>Shared function ports that function either as LCD driver segment outputs or general-purpose I/O ports.</p> <p>The IOS instruction is used to switch between the segment output and the general-purpose I/O port functions.</p> <ul style="list-style-type: none"> When used as segment output ports The IOS (Pwn=8) instruction is used to set the general-purpose I/O port. b0 to 3 = S17 to S20/PG0 to PG3 (0: Segment output, 1: PG0 to PG3) When used as general-purpose I/O ports The IOS instruction (Pwn=9) is used to set the general-purpose I/O port. b0 to 3 = S13 to S16/PH0 to PH3 (0: Segment output, 1: PH0 to PH3) <p>The IOS instruction (Pwn=6, 7) is used to switch the I/O direction. The directions of these pins can be set individually in 1-bit units.</p> <table border="0" style="margin-left: auto; margin-right: auto;"> <tr> <td style="border: 1px solid black; padding: 5px;">b0 = PG0</td> <td style="border: 1px solid black; padding: 5px;">b1 = PG1</td> <td style="border: 1px solid black; padding: 5px;">b2 = PG2</td> <td style="border: 1px solid black; padding: 5px;">b3 = PG3</td> <td style="border: 1px solid black; padding: 5px;">0: Input</td> <td style="border: 1px solid black; padding: 5px;">1: Output</td> <td style="border: 1px solid black; padding: 5px;">b0 = PH0</td> <td style="border: 1px solid black; padding: 5px;">b1 = PH1</td> <td style="border: 1px solid black; padding: 5px;">b2 = PH2</td> <td style="border: 1px solid black; padding: 5px;">b3 = PH3</td> <td style="border: 1px solid black; padding: 5px;">0: Input</td> <td style="border: 1px solid black; padding: 5px;">1: Output</td> </tr> </table> <p>In backup mode, if used as general-purpose I/O ports, they will be in the input disabled high-impedance state. If used as segment outputs, they will be held fixed at the low level.</p> <p>Although the general-purpose port/LCD port setting is a mask option, the setup with the IOS instruction described above is also necessary.</p>	b0 = PG0	b1 = PG1	b2 = PG2	b3 = PG3	0: Input	1: Output	b0 = PH0	b1 = PH1	b2 = PH2	b3 = PH3	0: Input	1: Output	<p>CMOS push-pull</p> 
b0 = PG0	b1 = PG1	b2 = PG2	b3 = PG3	0: Input	1: Output	b0 = PH0	b1 = PH1	b2 = PH2	b3 = PH3	0: Input	1: Output					
33 to 44	S12 to S1	O	<p>LCD driver segment output pins.</p> <p>A 1/4-duty 1/2-bias drive technique is used.</p> <p>The frame frequency is 75 Hz.</p> <p>In backup mode, the outputs are fixed at the low level.</p> <p>After a reset, the outputs are fixed at the low level.</p>	<p>CMOS push-pull</p> 												
45 46 47 48	COM4 COM3 COM2 COM1	O	<p>LCD driver common output pins.</p> <p>A 1/4-duty 1/2-bias drive technique is used.</p> <p>The frame frequency is 75 Hz.</p> <p>In backup mode, the outputs are fixed at the low level.</p> <p>After a reset, the outputs are fixed at the low level.</p>													
50 51 52 53	DBR4 DBR3 DBR2 DBR1	I	<p>LCD power supply step-up voltage inputs.</p>													

Continued on next page.

LC723481W/2W/3W

Continued from preceding page.

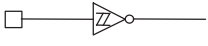
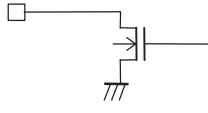
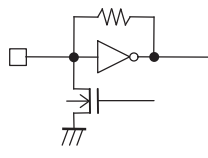
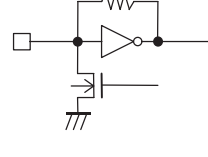
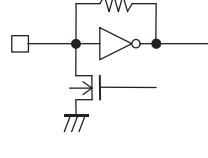
Pin No.	Pin	I/O	Function	I/O circuit																																													
54	BRES	I	<p>System reset input.</p> <p>In CPU operating mode or halt mode, applications must apply a low level for at least one full machine cycle to reset the system and restart execution with the PC set to location 0. This pin is connected in parallel with the internal power on reset circuit.</p>																																														
49	TU	O	<p>Tuning voltage generation circuit outputs.</p> <p>These pins include a n-ch transistor, and a tuning voltage can be generated by connecting external coil, diode, and capacitor components.</p>	<p style="text-align: center;">N-channel open-drain</p> 																																													
55	HCTR	I	<p>Special-purpose universal counter input port</p> <ul style="list-style-type: none"> To measure a frequency, set up HCTR frequency measurement mode and the measurement time with a UCS instruction (b3 = 0, b2 = 0) and start the count with a UCC instruction. <table border="1" style="width: 100%; border-collapse: collapse; margin: 10px 0;"> <thead> <tr> <th style="text-align: center;">UCS</th> <th style="text-align: center;">b3</th> <th style="text-align: center;">b2</th> <th style="text-align: center;">Input pin</th> <th style="text-align: center;">Measurement mode</th> <th style="text-align: center;">UCS</th> <th style="text-align: center;">b1</th> <th style="text-align: center;">b0</th> <th style="text-align: center;">Measurement time</th> </tr> </thead> <tbody> <tr> <td style="text-align: center;">0</td> <td style="text-align: center;">0</td> <td style="text-align: center;">0</td> <td style="text-align: center;">HCTR</td> <td style="text-align: center;">Frequency measurement</td> <td style="text-align: center;">0</td> <td style="text-align: center;">0</td> <td style="text-align: center;">0</td> <td style="text-align: center;">1 ms</td> </tr> <tr> <td style="text-align: center;">0</td> <td style="text-align: center;">0</td> <td style="text-align: center;">1</td> <td style="text-align: center;">—</td> <td style="text-align: center;">—</td> <td style="text-align: center;">0</td> <td style="text-align: center;">1</td> <td style="text-align: center;">0</td> <td style="text-align: center;">4 ms</td> </tr> <tr> <td style="text-align: center;">0</td> <td style="text-align: center;">1</td> <td style="text-align: center;">—</td> <td style="text-align: center;">—</td> <td style="text-align: center;">—</td> <td style="text-align: center;">1</td> <td style="text-align: center;">0</td> <td style="text-align: center;">0</td> <td style="text-align: center;">8 ms</td> </tr> <tr> <td style="text-align: center;">1</td> <td style="text-align: center;">0</td> <td style="text-align: center;">—</td> <td style="text-align: center;">—</td> <td style="text-align: center;">—</td> <td style="text-align: center;">1</td> <td style="text-align: center;">1</td> <td style="text-align: center;">0</td> <td style="text-align: center;">32 ms</td> </tr> </tbody> </table> <p>The CNTEND flag is set when the count completes. Since the input circuit functions as an AC amplifier in this mode, the input must be capacitance coupled.</p> <p>This pin goes to the input disabled state in backup mode, halt mode, PLL stop mode, and after a reset.</p>	UCS	b3	b2	Input pin	Measurement mode	UCS	b1	b0	Measurement time	0	0	0	HCTR	Frequency measurement	0	0	0	1 ms	0	0	1	—	—	0	1	0	4 ms	0	1	—	—	—	1	0	0	8 ms	1	0	—	—	—	1	1	0	32 ms	<p style="text-align: center;">CMOS amplifier input</p> 
UCS	b3	b2	Input pin	Measurement mode	UCS	b1	b0	Measurement time																																									
0	0	0	HCTR	Frequency measurement	0	0	0	1 ms																																									
0	0	1	—	—	0	1	0	4 ms																																									
0	1	—	—	—	1	0	0	8 ms																																									
1	0	—	—	—	1	1	0	32 ms																																									
57	FMIN	I	<p>FM VCO (local oscillator) input.</p> <p>This pin is selected with the PLL instruction CW1.</p> <table border="1" style="width: 100%; border-collapse: collapse; margin: 10px 0;"> <thead> <tr> <th style="text-align: center;">CW1</th> <th style="text-align: center;">b1,</th> <th style="text-align: center;">b0</th> <th style="text-align: center;">Bandwidth</th> </tr> </thead> <tbody> <tr> <td style="text-align: center;">0</td> <td style="text-align: center;">0</td> <td style="text-align: center;">0</td> <td style="text-align: center;">10 to 250 MHz</td> </tr> </tbody> </table> <p>The input must be capacitor coupled.</p> <p>Input is disabled in backup mode, in halt mode, after a reset, and in PLL stop mode.</p>	CW1	b1,	b0	Bandwidth	0	0	0	10 to 250 MHz	<p style="text-align: center;">CMOS amplifier input</p> 																																					
CW1	b1,	b0	Bandwidth																																														
0	0	0	10 to 250 MHz																																														
58	AMIN	I	<p>AM VCO (local oscillator) input.</p> <p>This pin and the bandwidth are selected with the PLL instruction CW1.</p> <table border="1" style="width: 100%; border-collapse: collapse; margin: 10px 0;"> <thead> <tr> <th style="text-align: center;">CW1</th> <th style="text-align: center;">b1,</th> <th style="text-align: center;">b0</th> <th style="text-align: center;">Bandwidth</th> </tr> </thead> <tbody> <tr> <td style="text-align: center;">1</td> <td style="text-align: center;">0</td> <td style="text-align: center;">0</td> <td style="text-align: center;">2 to 40 MHz (SW)</td> </tr> <tr> <td style="text-align: center;">1</td> <td style="text-align: center;">1</td> <td style="text-align: center;">0</td> <td style="text-align: center;">0.5 to 10 MHz (MW, LW)</td> </tr> </tbody> </table> <p>The input must be capacitor coupled.</p> <p>Input is disabled in backup mode, in halt mode, after a reset, and in PLL stop mode.</p>	CW1	b1,	b0	Bandwidth	1	0	0	2 to 40 MHz (SW)	1	1	0	0.5 to 10 MHz (MW, LW)	<p style="text-align: center;">CMOS amplifier input</p> 																																	
CW1	b1,	b0	Bandwidth																																														
1	0	0	2 to 40 MHz (SW)																																														
1	1	0	0.5 to 10 MHz (MW, LW)																																														

Continued on next page.

LC723481W/2W/3W

Continued from preceding page.

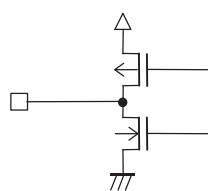
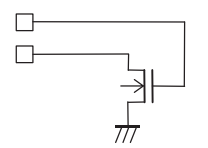
Pin No.	Pin	I/O	Function	I/O circuit
60	EO	O	<p>Main charge pump output. When the local oscillator frequency divided by N is higher than the reference frequency a high level is output, when lower, a low level is output. The pin is set to the high-impedance state when the frequencies match.</p> <p>Output goes to the high-impedance state in backup mode, in halt mode, after a reset, and in PLL stop mode.</p>	<p>CMOS push-pull</p> 
61 62	AIN AOUT	O	<p>Connections for the built-in transistor used to form a low-pass filter.</p>	
24 59 56	V _{SS} V _{SS} V _{DD}	—	<p>Power supply pin. This pin must be connected to ground. This pin must be connected to ground. This pin must be connected to V_{DD}.</p>	—

Note 2: When a pin in an I/O switching port is used as an output, applications must first set up the data with an OUT, SPB, or RPB instruction and then set up output mode with an IOS instruction.

Sample Application for Tuning Voltage Generation Circuit

Sample Application for Low-Pass Filter Amplifier

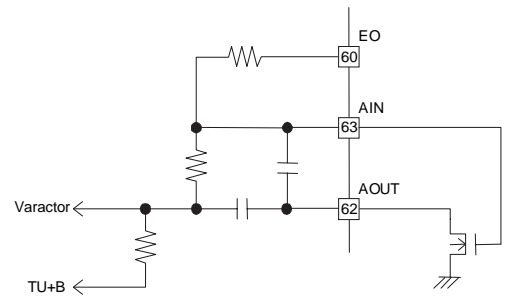
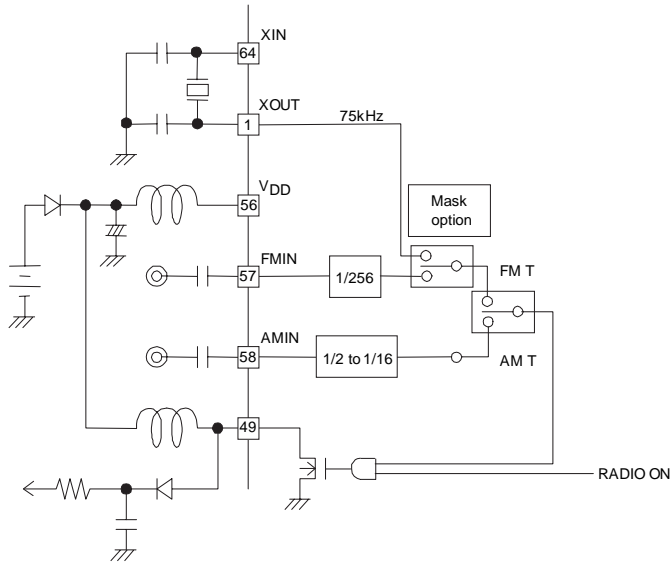

LC723481 DC-DC converter load = 100 kW (When VDD = 1.8 V)

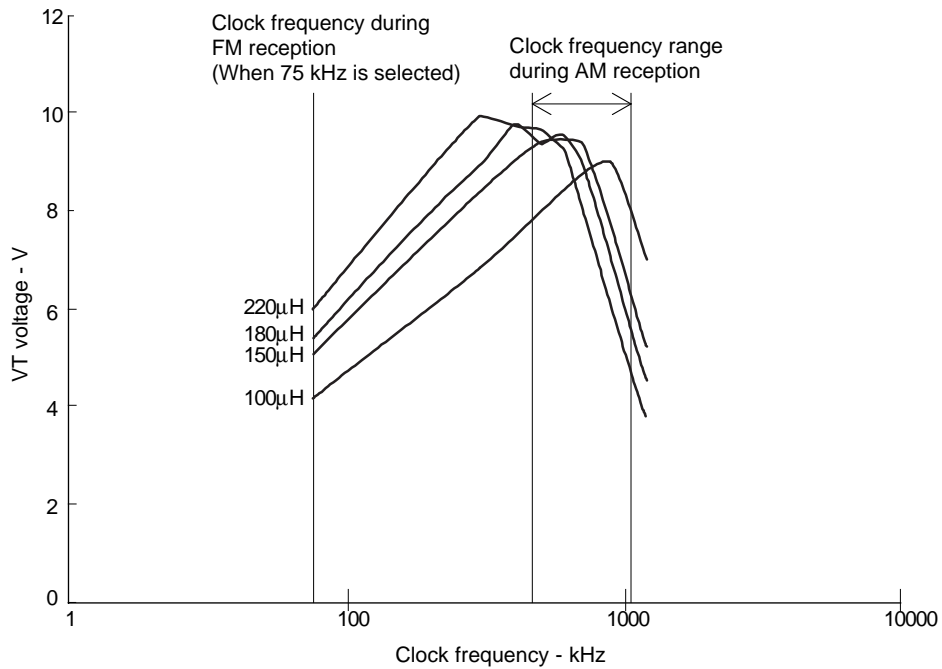

LC723481W, 723482W and 723483W Series Instruction Set

Terminology

- ADDR : Program memory address
- b : Borrow
- C : Carry
- DH : Data memory address High (Row address) [2 bits]
- DL : Data memory address Low (Column address) [4 bits]
- I : Immediate data [4 bits]
- M : Data memory address
- N : Bit position [4 bits]
- Rn : Resister number [4 bits]
- Pn : Port number [4 bits]
- PW : Port control word number [4 bits]
- r : General register (One of the addresses from 00H to 0FH of BANK0)
- (), [] : Contents of register or memory
- M (DH, DL) : Data memory specified by DH, DL

Instruc-tions	Mnemonic	Operand		Function	Operations function	Instruction format														
		1st	2nd			f	e	d	c	b	a	9	8	7	6	5	4	3	2	1
Addition instructions	AD	r	M	Add M to r	$r \leftarrow (r) + (M)$	0	1	0	0	0	0	DH	DL	r						
	ADS	r	M	Add M to r, then skip if carry	$r \leftarrow (r) + (M)$, skip if carry	0	1	0	0	0	1	DH	DL	r						
	AC	r	M	Add M to r with carry	$r \leftarrow (r) + (M) + C$	0	1	0	0	1	0	DH	DL	r						
	ACS	r	M	Add M to r with carry, then skip if carry	$r \leftarrow (r) + (M) + C$ skip if carry	0	1	0	0	1	1	DH	DL	r						
	AI	M	I	Add I to M	$M \leftarrow (M) + I$	0	1	0	1	0	0	DH	DL	I						
	AIS	M	I	Add I to M, then skip if carry	$M \leftarrow (M) + I$, skip if carry	0	1	0	1	0	1	DH	DL	I						
	AIC	M	I	Add I to M with carry	$M \leftarrow (M) + I + C$	0	1	0	1	1	0	DH	DL	I						
Subtraction instructions	AICS	M	I	Add I to M with carry, then skip if carry	$M \leftarrow (M) + I + C$, skip if carry	0	1	0	1	1	1	DH	DL	I						
	SU	r	M	Subtract M from r	$r \leftarrow (r) - (M)$	0	1	1	0	0	0	DH	DL	r						
	SUS	r	M	Subtract M from r, then skip if borrow	$r \leftarrow (r) - (M)$, skip if borrow	0	1	1	0	0	1	DH	DL	r						
	SB	r	M	Subtract M from r with borrow	$r \leftarrow (r) - (M) - b$	0	1	1	0	1	0	DH	DL	r						
	SBS	r	M	Subtract M from r with borrow, then skip if borrow	$r \leftarrow (r) - (M) - b$, skip if borrow	0	1	1	0	1	1	DH	DL	r						
	SI	M	I	Subtract I from M	$M \leftarrow (M) - I$	0	1	1	1	0	0	DH	DL	I						
	SIS	M	I	Subtract I from M, then skip if borrow	$M \leftarrow (M) - I$, skip if borrow	0	1	1	1	0	1	DH	DL	I						
SIB	M	I	Subtract I from M with borrow	$M \leftarrow (M) - I - b$	0	1	1	1	1	0	DH	DL	I							
SIBS	M	I	Subtract I from M with borrow, then skip if borrow	$M \leftarrow (M) - I - b$, skip if borrow	0	1	1	1	1	1	DH	DL	I							

Continued on next page.

LC723481W/2W/3W

Continued from preceding page.

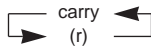
Instructions	Mnemonic	Operand		Function	Operations function	Instruction format															
		1st	2nd			f	e	d	c	b	a	9	8	7	6	5	4	3	2	1	0
Comparison instructions	SEQ	r	M	Skip if r equal to M	$(r) - (M)$, skip if zero	0	0	0	1	0	0	DH	DL							r	
	SEQL	M	I	Skip if M equal to I	$(M) - I$, skip if zero	0	0	0	1	1	0	DH	DL							I	
	SNEI	M	I	Skip if M not equal to I	$(M) - I$, skip if not zero	0	0	0	0	0	1	DH	DL							I	
	SGE	r	M	Skip if r is greater than or equal to M	$(r) - (M)$, skip if not borrow	0	0	0	1	1	0	DH	DL							r	
	SGEL	M	I	Skip if M is greater than equal to I	$(M) - I$, skip if not borrow	0	0	0	1	1	1	DH	DL							I	
	SLEI	M	I	Skip if M is less than I	$(M) - I$, skip if borrow	0	0	0	0	1	1	DH	DL							I	
Logic instructions	AND	r	M	AND M with r	$r \leftarrow (r) \text{ AND } (M)$	0	0	1	0	0	0	DH	DL						r		
	ANDI	M	I	AND I with M	$M \leftarrow (M) \text{ AND } I$	0	0	1	0	0	1	DH	DL						I		
	OR	r	M	OR M with r	$r \leftarrow (r) \text{ OR } (M)$	0	0	1	0	1	0	DH	DL						r		
	ORI	M	I	OR I with M	$M \leftarrow (M) \text{ OR } I$	0	0	1	0	1	1	DH	DL						I		
	EXL	r	M	Exclusive OR M with r	$r \leftarrow (r) \text{ XOR } (M)$	0	0	1	1	0	0	DH	DL						r		
	EXLI	M	I	Exclusive OR M with M	$M \leftarrow (M) \text{ XOR } I$	0	0	1	1	1	0	DH	DL						I		
Transfer instructions	SHR	r		Shift r right with carry		0	0	0	0	0	0	0	0	1	1	1	0		r		
	LD	r	M	Load M to r	$r \leftarrow (M)$	1	1	0	1	0	0	DH	DL						r		
	ST	M	r	Store r to M	$M \leftarrow (r)$	1	1	0	1	0	1	DH	DL						r		
	MVRD	r	M	Move M to destination M referring to r in the same row	$[DH, Rn] \leftarrow (M)$	1	1	0	1	1	0	DH	DL						r		
	MVRS	M	r	Move source M referring to r to M in the same row	$M \leftarrow [DH, Rn]$	1	1	0	1	1	1	DH	DL						r		
	MVSR	M1	M2	Move M to M in the same row	$[DH, DL1] \leftarrow [DH, DL2]$	1	1	1	0	0	0	DH	DL1						DL2		
Bit test instructions	MVI	M	I	Move I to M	$M \leftarrow I$	1	1	1	0	0	1	DH	DL						I		
	TMT	M	N	Test M bits, then skip if all bits specified are true	if $M(N) = \text{all } 1\text{s}$, then skip	1	1	1	1	0	0	DH	DL						N		
Jump and subroutine call instructions	TMF	M	N	Test M bits, then skip if all bits specified are false	if $M(N) = \text{all } 0\text{s}$, then skip	1	1	1	1	0	1	DH	DL						N		
	JMP	ADDR		Jump to the address	$PC \leftarrow ADDR$	1	0	0	ADDR (13 bits)												
	CAL	ADDR		Call subroutine	$PC \leftarrow ADDR$ $Stack \leftarrow (PC) + 1$	1	0	1	ADDR (13 bits)												
	RT			Return from subroutine	$PC \leftarrow Stack$	0	0	0	0	0	0	0	0	0	1	0	0	0			
Jump and subroutine call instructions	RTI			Return from interrupt	$PC \leftarrow Stack$, $BANK \leftarrow Stack$, $CARRY \leftarrow Stack$	0	0	0	0	0	0	0	0	1	0	0	1				

Continued on next page.

LC723481W/2W/3W

Continued from preceding page.

Instructions	Mnemonic	Operand		Function	Operations function	Instruction format															
		1st	2nd			f	e	d	c	b	a	9	8	7	6	5	4	3	2	1	0
Status register instructions	SS	SWR	N	Set status register	(Status W-reg) $N \leftarrow 1$	1	1	1	1	1	1	1	1	0	0	SWR	N				
	RS	SWR	N	Reset status register	(Status W-reg) $N \leftarrow 0$	1	1	1	1	1	1	1	1	0	1	SWR	N				
	TST	SRR	N	Test status register true	if (Status R-reg) $N = \text{all}$	1	1	1	1	1	0	0	0	0	SRR	N					
	TSF	SRR	N	Test status register false	if (Status R-reg) $N = \text{all}$	1	1	1	1	1	0	0	0	1	SRR	N					
	TUL	N		Test Unlock F/F	if Unlock F/F (N) = all 0s, then skip	0	0	0	0	0	0	0	0	1	1	0	1	N			
Hardware control instructions	PLL	M		Load M to PLL register	PLL reg \leftarrow PLL data	1	1	1	1	1	0	DH	DL	r							
	UCS	I		Set I to UCCW1	UCCW1 \leftarrow I	0	0	0	0	0	0	0	0	0	0	1	I				
	UCC	I		Set I to UCCW2	UCCW2 \leftarrow I	0	0	0	0	0	0	0	0	0	1	0	I				
	BEEP	I		Beep control	BEEP reg \leftarrow I	0	0	0	0	0	0	0	0	1	1	0	I				
	DZC	I		Dead zone control	DZC reg \leftarrow I	0	0	0	0	0	0	0	0	1	0	1	1	I			
	TMS	I		Set timer register	Timer reg \leftarrow I	0	0	0	0	0	0	0	0	1	1	0	0	I			
	IOS	PWn	N	Set port control word	IOS reg PWn \leftarrow N	1	1	1	1	1	1	1	0	PWn	N						
I/O instructions	IN	M	Pn	Input port data to M	$M \leftarrow (Pn)$	1	1	1	0	1	0	DH	DL	Pn							
	OUT	M	Pn	Output contents of M to port	$P1n \leftarrow M$	1	1	1	0	1	1	DH	DL	Pn							
	INR	M	Pn	Input port data to M	$M \leftarrow (Pn)$	0	0	1	1	1	0	DH	DL	Pn							
	SPB	P1n	N	Set port1 bits	$(Pn)N \leftarrow 1$	0	0	0	0	0	0	1	0	Pn	N						
	RPB	P1n	N	Reset port1 bits	$(Pn)N \leftarrow 0$	0	0	0	0	0	0	1	1	Pn	N						
	TPT	P1n	N	Test port1 bits, then skip if all bits specified are true	if $(Pn)N = \text{all 1s}$, then skip	1	1	1	1	1	1	0	0	Pn	N						
Bank switching instructions	TPF	P1n	N	Test port1 bits, then skip if all bits specified are false	if $(Pn)N = \text{all 0s}$, then skip	1	1	1	1	1	1	0	1	Pn	N						
	BANK	I		Select Bank	BANK \leftarrow I	0	0	0	0	0	0	0	0	1	1	1	I				
LCD instructions	LCDA	M	I	Output segment pattern to LCD digit direct	LCD (DIGIT) \leftarrow M	1	1	0	0	0	0	DH	DL	DIGIT							
	LCDB	M	I	Output segment pattern to LCD digit direct	LCD (DIGIT) \leftarrow M	1	1	0	0	0	1	DH	DL	DIGIT							
	LCPA	M	I	Output segment pattern to LCD digit through LA	LCD (DIGIT) \leftarrow LA \leftarrow M	1	1	0	0	1	0	DH	DL	DIGIT							
	LCPB	M	I	Output segment pattern to LCD digit through LA	LCD (DIGIT) \leftarrow LA \leftarrow M	1	1	0	0	1	1	DH	DL	DIGIT							
Other instructions	HALT	I		Halt mode control	HALT reg \leftarrow I, then CPU clock stop	0	0	0	0	0	0	0	0	0	1	0	0	I			
	CKSTP			Clock stop	Stop x'tal OSC	0	0	0	0	0	0	0	0	0	1	0	1				
	NOP			No operation	No operation	0	0	0	0	0	0	0	0	0	0	0	0				

- Specifications of any and all SANYO products described or contained herein stipulate the performance, characteristics, and functions of the described products in the independent state, and are not guarantees of the performance, characteristics, and functions of the described products as mounted in the customer's products or equipment. To verify symptoms and states that cannot be evaluated in an independent device, the customer should always evaluate and test devices mounted in the customer's products or equipment.
- SANYO Electric Co., Ltd. strives to supply high-quality high-reliability products. However, any and all semiconductor products fail with some probability. It is possible that these probabilistic failures could give rise to accidents or events that could endanger human lives, that could give rise to smoke or fire, or that could cause damage to other property. When designing equipment, adopt safety measures so that these kinds of accidents or events cannot occur. Such measures include but are not limited to protective circuits and error prevention circuits for safe design, redundant design, and structural design.
- In the event that any or all SANYO products (including technical data, services) described or contained herein are controlled under any of applicable local export control laws and regulations, such products must not be exported without obtaining the export license from the authorities concerned in accordance with the above law.
- No part of this publication may be reproduced or transmitted in any form or by any means, electronic or mechanical, including photocopying and recording, or any information storage or retrieval system, or otherwise, without the prior written permission of SANYO Electric Co., Ltd.
- Any and all information described or contained herein are subject to change without notice due to product/technology improvement, etc. When designing equipment, refer to the "Delivery Specification" for the SANYO product that you intend to use.
- Information (including circuit diagrams and circuit parameters) herein is for example only; it is not guaranteed for volume production. SANYO believes information herein is accurate and reliable, but no guarantees are made or implied regarding its use or any infringements of intellectual property rights or other rights of third parties.

This catalog provides information as of November, 2002. Specifications and information herein are subject to change without notice.