

TOLERANCE UNLESS SPECIFIED =

.XXX= +/- .005

.XX= +/- .015

FRACTIONS= +/- .032

PRODUCTION TESTS

12-1600.DC2

URNS RATIO = 100%

DC RESISTANCE IN OHMS	1-3 =	77 NOM
	4-6 =	90 NOM
	7-9 =	0.32 NOM
	10-12 =	0.37 NOM

MAX EXCITATION CURRENT = 0.030 A

APPLY 230V 60HZ 1-6 (3+4)

PRI WDGS 114.5 TO 115.5 V

SEC WDGS 7.3 TO 7.85 V

HIPOT: 4000V P-S
 4000V P,S, TO CORE
 600V P-P, S-S

IMPREGNATION NOTES: PREHEAT 2 HRS
 PINS TO BE FREE OF IMPREGNATION.

FINAL ASSEMBLY NOTES

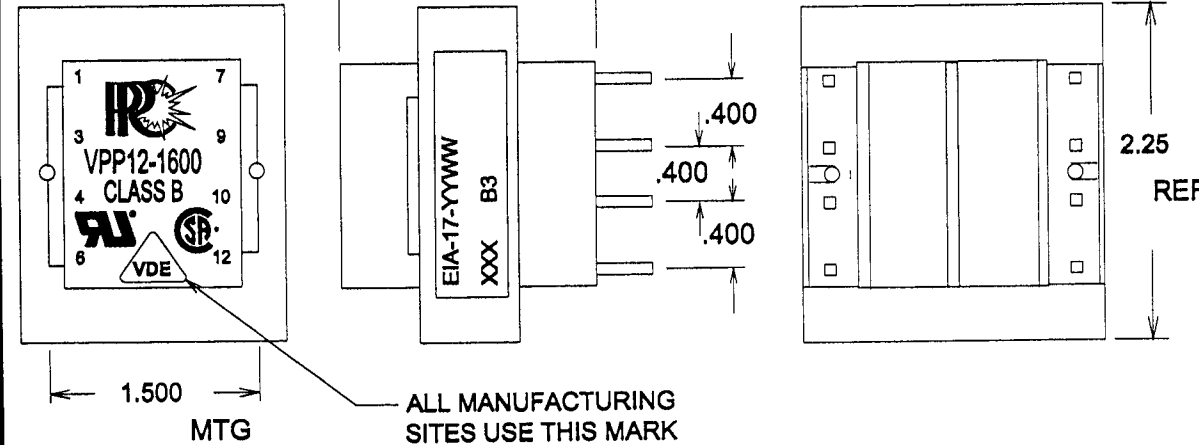

ALL MANUFACTURING SITES USE THIS MARK

PC PINS .036 SQ

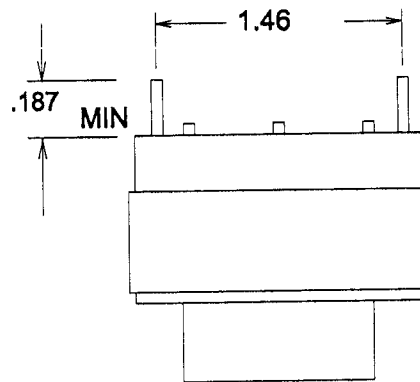

115/230V
50/60 HZ

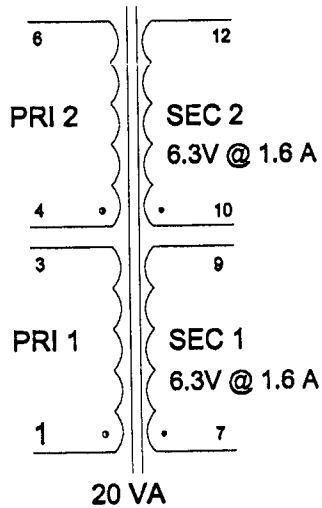

20 VA

METHOD 1 X 1
LEAVE OFF LAST "I" PCS

MARKING SEE LABEL DETAIL ABOVE
APPLY PART NO. LABEL AFTER IMPREGNATION



PART NO.: VPP12-1600