

S1A - S1M

1.0A SURFACE MOUNT GLASS PASSIVATED RECTIFIER

Features

- Glass Passivated Die Construction
- Low Forward Voltage Drop and High Current Capability
- Surge Overload Rating to 30A Peak
- Ideally Suited for Automated Assembly

Mechanical Data

- Case: Molded Plastic
- Case Material - UL Flammability Rating Classification 94V-0
- Moisture sensitivity: Level 1 per J-STD-020A
- Terminals: Solder Plated Terminal - Solderable per MIL-STD-202, Method 208
- Polarity: Cathode Band or Cathode Notch
- SMA Weight: 0.064 grams (approx.)
- SMB Weight: 0.093 grams (approx.)
- Marking: Type Number, See Page 2
- Ordering Information: See Page 2

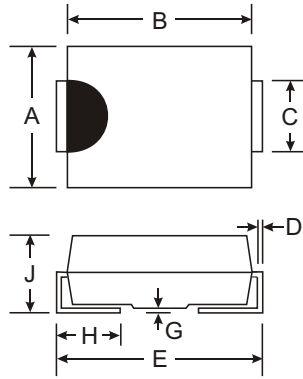

| Dim | SMA | | SMB | |
|----------------------|------|------|------|------|
| | Min | Max | Min | Max |
| A | 2.29 | 2.92 | 3.30 | 3.94 |
| B | 4.00 | 4.60 | 4.06 | 4.57 |
| C | 1.27 | 1.63 | 1.96 | 2.21 |
| D | 0.15 | 0.31 | 0.15 | 0.31 |
| E | 4.80 | 5.59 | 5.00 | 5.59 |
| G | 0.10 | 0.20 | 0.10 | 0.20 |
| H | 0.76 | 1.52 | 0.76 | 1.52 |
| J | 2.01 | 2.62 | 2.00 | 2.62 |
| All Dimensions in mm | | | | |

A, B, D, G, J, K, M Suffix Designates SMA Package
 AB, BB, DB, GB, JB, KB, MB Suffix Designates SMB Package

Maximum Ratings and Electrical Characteristics T_A = 25°C unless otherwise specified

Single phase, half wave, 60Hz, resistive or inductive load.
 For capacitive load, derate current by 20%.

| Characteristic | Symbol | S1 A/AB | S1 B/BB | S1 D/DB | S1 G/GB | S1 J/JB | S1 K/KB | S1 M/MB | Unit | |
|---|--|-------------|------------|------------|------------|------------|------------|------------|------|------|
| Peak Repetitive Reverse Voltage Working Peak Reverse Voltage DC Blocking Voltage | V _{RRM} V _{RWM} V _R | 50 | 100 | 200 | 400 | 600 | 800 | 1000 | V | |
| RMS Reverse Voltage | V _{R(RMS)} | 35 | 70 | 140 | 280 | 420 | 560 | 700 | V | |
| Average Rectified Output Current @ T _T = 100°C | I _O | 1.0 | | | | | | | | A |
| Non-Repetitive Peak Forward Surge Current 8.3ms Single half sine-wave superimposed on rated load (JEDEC Method) | I _{FSM} | 30 | | | | | | | | A |
| Forward Voltage @ I _F = 1.0A | V _{FM} | 1.1 | | | | | | | | V |
| Peak Reverse Leakage Current @ T _A = 25°C at Rated DC Blocking Voltage @ T _A = 125°C | I _{RM} | 5.0 100 | | | | | | | | μA |
| Typical Total Capacitance (Note 1) | C _T | 10 | | | | | | | | pF |
| Typical Thermal Resistance, Junction to Terminal (Note 2) | R _{θJT} | 30 | | | | | | | | °C/W |
| Operating and Storage Temperature Range | T _j , T _{STG} | -65 to +150 | | | | | | | | °C |

- Notes: 1. Measured at 1.0MHz and applied reverse voltage of 4.0V DC.
 2. Thermal Resistance Junction to Terminal, unit mounted on PC board with 5.0 mm² (0.013 mm thick) copper pads as heat sink.

Ordering Information (Note 3)

| Device* | Packaging | Shipping |
|-----------------|------------|--------------------------------------|
| S1x-7 S1xB-7 | SMA SMB | 5000/Tape & Reel 3000/Tape & Reel |

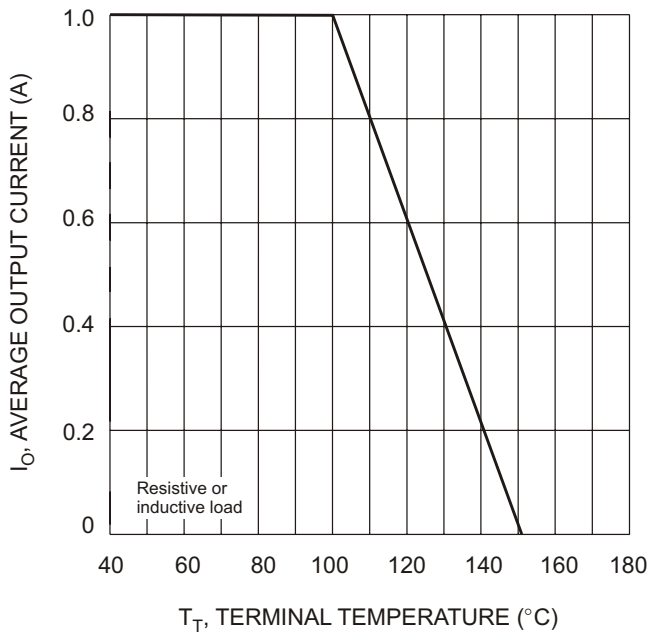

Fig. 1 Forward Current Derating Curve

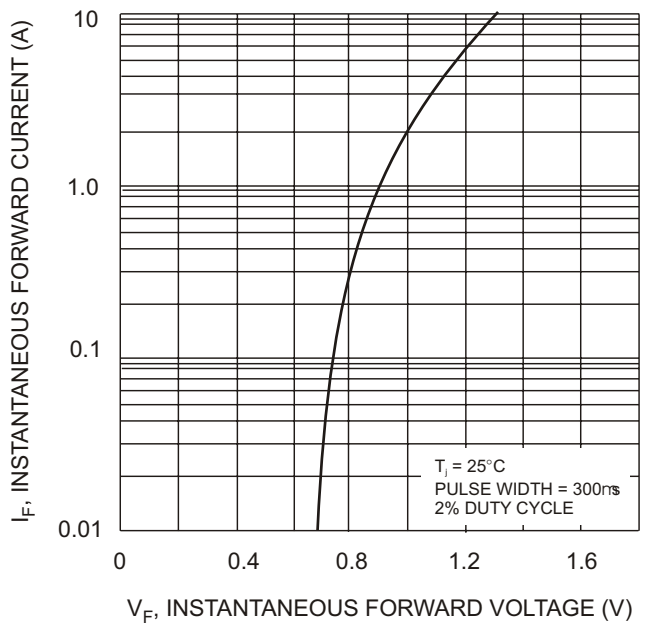

Fig. 2 Typical Forward Characteristics

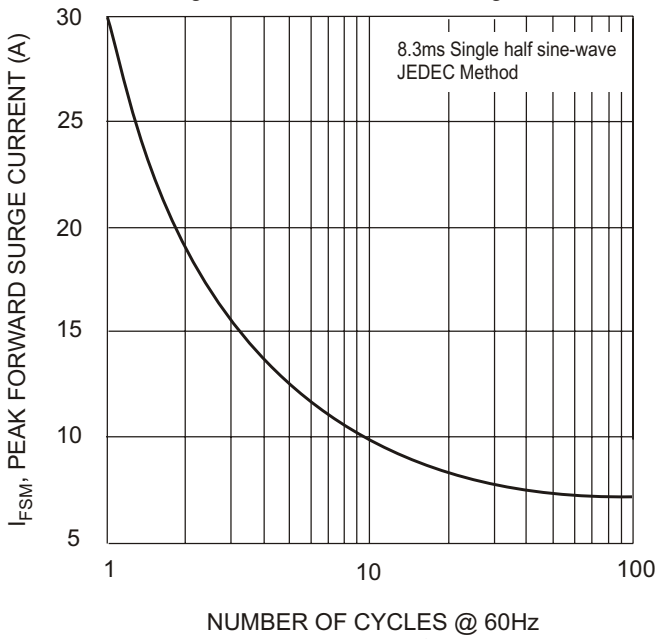

Fig. 3 Typical Forward Characteristics

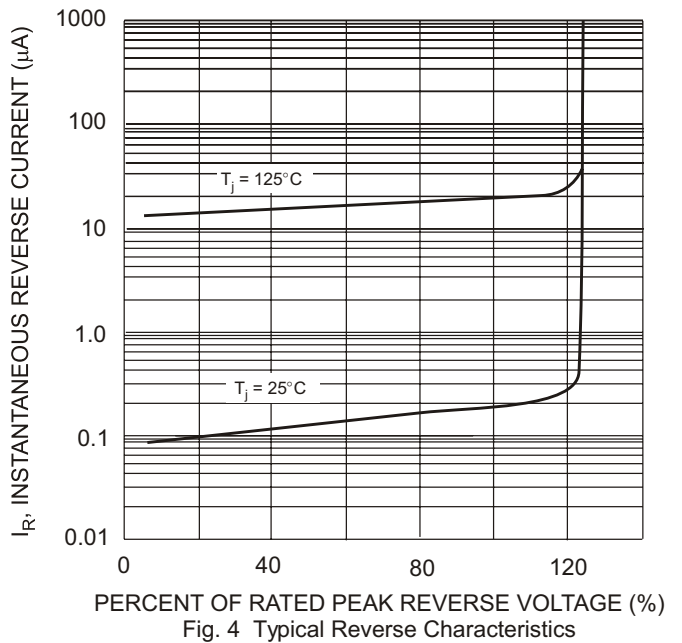

Fig. 4 Typical Reverse Characteristics