

Customer Information Sheet

DRAWING No.: H8505-XX

SHEET 2 OF 2

IF IN DOUBT - ASK

©

NOT TO SCALE

THIRD ANGLE PROJECTION

ALL DIMENSIONS IN mm

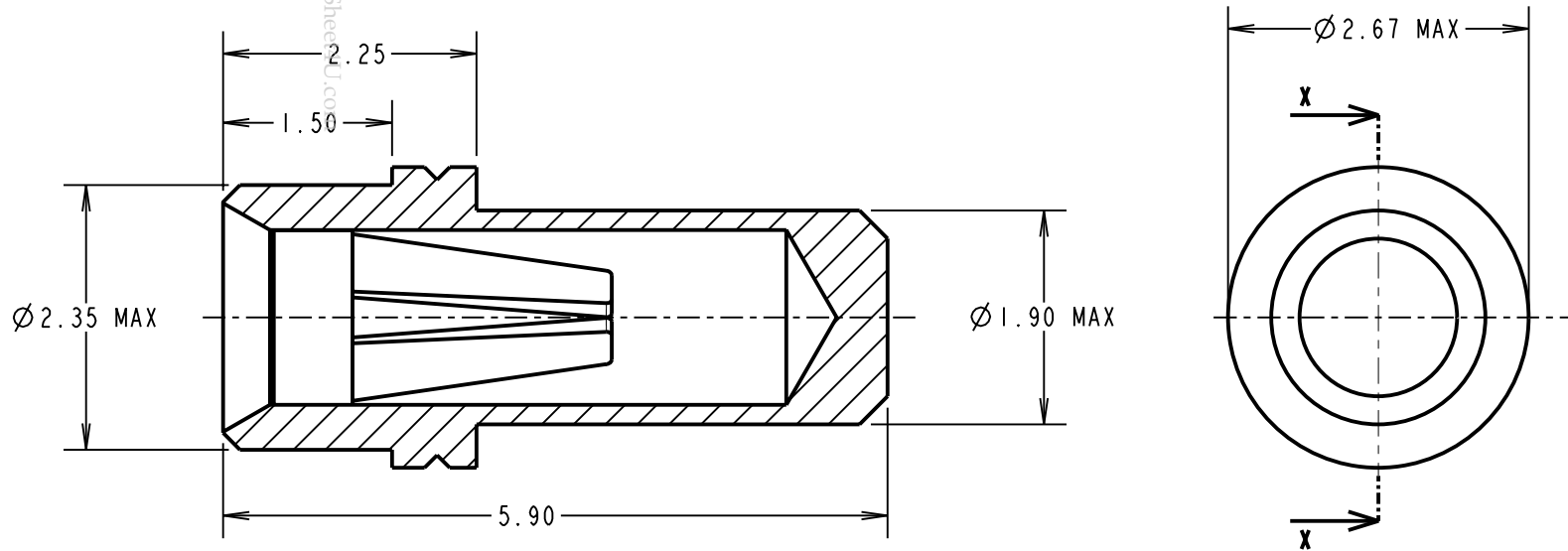

ORDER CODE:
H8505-XX

FINISH: _____
 01 = 100% TIN SHELL, GOLD CLIP
 05 = GOLD SHELL, GOLD CLIP
 46 = 100% TIN SHELL, 100% TIN CLIP

SPECIFICATION:

MATERIAL:
 CONTACT SHELL = BRASS
 CONTACT CLIP = BERYLLIUM COPPER

FINISH:
 01 = 4µ 100% TIN SHELL, 0.15µ GOLD CLIP
 05 = 0.1µ GOLD SHELL, 0.15µ GOLD CLIP
 46 = 4µ 100% TIN SHELL, 3µ 100% TIN CLIP

ELECTRICAL:
 CURRENT RATING AT 25°C = 10A MAX
 CURRENT RATING AT 85°C = 7.5A MAX
 CONTACT RESISTANCE = 25 mΩ MAX

MECHANICAL:
 INSERTION FORCE (Ø0.8mm GAUGE) = 5N MAX, 1.5N MIN
 WITHDRAWAL FORCE (Ø0.8mm GAUGE) = 3.0N MAX, 1.0N MIN

DURABILITY:
 01, 05 = 1000 OPERATIONS
 46 = 100 OPERATIONS

ENVIRONMENTAL:
 OPERATING TEMPERATURE = -55°C TO +125°C

MARKING:

SECTION X-X

NOTES:

- FOR ELECTRICAL/MECHANICAL SPECIFICATION, SEE COMPONENT SPECIFICATION C010XX (LATEST ISSUE).
- MAXIMUM PIN LENGTH = 4.85mm.
- RECOMMENDED MOUNTING HOLE SIZE = Ø2.01-1.91mm.
- RECOMMENDED MATING PIN SIZE = Ø0.85-0.60mm.
- MAXIMUM CONTACT DEPTH = 3.30mm.

CP	11	17.12.09	10616
NAME	ISS.	DATE	C/NOTE
APPROVED:		C.PENROSE	
CHECKED:		R.ADDE	
DRAWN:		A. J. FILLINGHAM	
CUSTOMER REF.:			
ASSEMBLY DRG:			

HARWIN

THIS DRAWING AND ANY INFORMATION OR DESCRIPTIVE MATTER SET OUT HEREON ARE CONFIDENTIAL AND COPYRIGHT PROPERTY OF THE HARWIN GROUP AND MUST NOT BE DISCLOSED, LOANED, COPIED OR USED FOR MANUFACTURING, TENDERING OR FOR ANY OTHER PURPOSE WITHOUT THEIR WRITTEN PERMISSION.

TOLERANCES
 X. = ±1mm
 X.X = ±0.25mm
 X.XX = ±0.10mm
 X.XXX = ±0.01mm
 ANGLES = ±5°
 UNLESS STATED

MATERIAL:
 SEE ABOVE

FINISH: SEE ABOVE

S/AREA: mm²

TITLE:
 Ø0.8mm SOCKET ASSEMBLY

DRAWING NUMBER:
H8505-XX

SHT 2 OF 2

HARWIN USA
 TEL: 603 893 5376
 FAX: 603 893 5396
 mis@harwin.com

HARWIN Europe (UK)
 TEL: 023 9231 4545
 FAX: 023 9231 4590
 mis@harwin.co.uk

HARWIN Asia
 TEL: +65 6 779 4909
 FAX: +65 6 779 3868
 mis@harwin.com.sg