

150mA Low Dropout Voltage Regulators

The Semiconductor PJ2950 and PJ2951 are a low power voltage regulators. These devices are excellent choice for use in battery-powered applications such as cordless telephone, radio control systems, and portable computers.

The PJ2950 and PJ2951 features very low quiescent current ($75 \mu\text{A}$ Typ.) and very low drop output voltage (Typ. $40 \mu\text{V}$ at light load and 380mV at 100mA). This includes a tight initial tolerance of 0.5% typ., extremely good load and line regulation 0.05% typ. and very low output temperature coefficient, making the PJ2950/PJ2951 useful as a low-power voltage reference. Other key additional feature of this unregulated input voltage transient of -20V below ground (reverse battery).

FEATURES

- Output accuracy 5V & 3.3V, 150 mA output
- Very low quiescent current
- Low dropout voltage
- Extremely tight load and line regulation
- Very low temperature coefficient
- Need only $1 \mu\text{F}$ for stability
- Unregulated DC input can withstand -20V reverse battery and $+60\text{V}$ positive transients
- Direct replacement for PJ2950/PJ2951 sockets

PJ2951 VERSIONS ONLY

- Error Flag warns of output dropout
- Logic-Controlled electronic shutdown
- Output programmable from 1.24 to 29V

APPLICATIONS

- Battery powered systems
- Portable instrumentation
- Avionics
- Automotive Electronics
- SMPS Post-Regulator
- Voltage Reference
- Portable/Palm top / Notebook computers
- Portable consumer equipment
- Radio control systems
- Cordless telephones

The error flag output feature is used as power-on reset for warn of a low output voltage, due to following batteries on input. Other feature is the logic-compatible shutdown input which enable the regulator to be switched on and off. The PJ2950 is offered in 3-pin TO-92 package compatible with other 5 volt regulators. The PJ2951 is available in 8-pin plastic, SOP-8 package.

The regulator output voltage may be pin-strapped for a 5 & 3.3 volt of programmed from 1.24 volt to 29 volts with external pair of resistors. Using of as design, processing and testing techniques make our PJ2950 and PJ2951 superior over similar products.

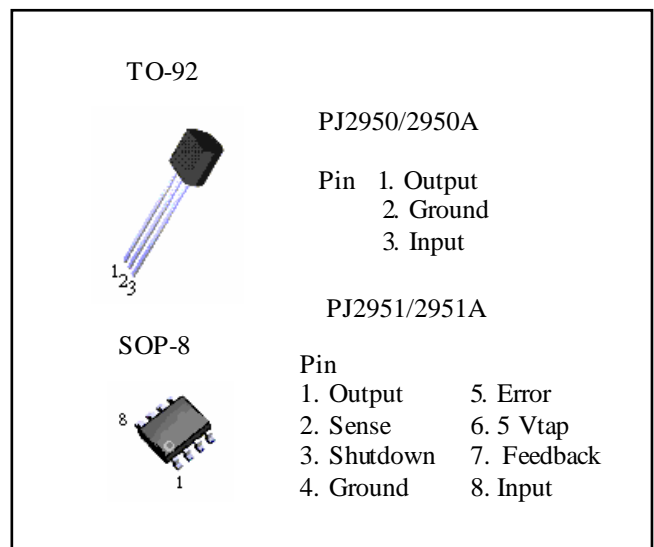

ORDERING INFORMATION

Device	Operating Temperature	Package
PJ2950ACT	-20 ~ +85 °C	TO-92
PJ2950CT		
PJ2950ACT-3.0		
PJ2950CT-3.0		
PJ2950ACT-3.3		
PJ2950CT-3.3		
PJ2951ACS		SOP-8
PJ2951CS		
PJ2951ACS-3.3		
PJ2951CS-3.3		

150mA Low Dropout Voltage Regulators

ABSOLUTE MAXIMUM RATINGS

Power Dissipation.....Internally Limited
 Lead Temp.(Soldering, 5 Seconds).....260°C
 Storage Temperature Range.....-65 to +150°C
 Operating Junction Temperature Range
 PJ2951..... -20 to +125°C
 PJ2950A / PJ2950
 PJ2951A / PJ2951.....-20 to +125°C

Input Supply Voltage..... -20 to +60V
 Feedback Input Voltage.....-1.5 to +30V
 Shutdown Input Voltage..... -0.3 to +30V
 Error Comparator Output.....-0.3 to +30V
 ECD Rating is to be determined

ELECTRICAL CHARACTERISTICS at $V_s=15V$, $T_a=25^\circ C$, unless otherwise noted.

PARAMETER	CONDITIONS (Note 2)	PJ2950A/PJ2951A			PJ2950/PJ2951			UNITS
		Min	Typ	Max	Min	Typ	Max	
Output Voltage	$T_j=25^\circ C$ $-25^\circ C \leq T_j \leq 85^\circ C$ Full Operating Temp.	0.995 V _o 0.990 V _o 0.988 V _o	5.0 / 3.3 / 3.0	1.005 V _o 1.010 V _o 1.012 V _o	0.990 V _o 0.985 V _o 0.983 V _o	5.0 / 3.3 / 3.0	1.010 V _o 1.015 V _o 1.017 V _o	V
Output Voltage	$100 \mu A \leq I_L \leq 100 mA$ $T_j \leq T_{jMAX}$	0.986 V _o		1.014 V _o	0.985 V _o		1.015 V _o	V
Output Voltage Temperature Coefficient	(Note 1)		20			50		ppm/°C
Line Regulation (Note 3)	$6V \leq V_{in} \leq 30V$ (Note 4)		0.03	0.2		0.04	0.2	%
Load Regulation (Note 3)	$100 \mu A \leq I_L \leq 100 mA$		0.04	0.1		0.1	0.2	%
Dropout Voltage (Note 5)	$I_L=100 \mu A$		40	80		40	80	mV
	$I_L=100 mA$		250	300		250	300	mV
	$I_L=150 mA$		300	450		300	450	mV
Ground Current	$I_L=100 \mu A$		75	120		75	120	μA
	$I_L=100 mA$		1.7	2.5		1.7	2.5	mA
	$I_L=150 mA$		4	6		4	6	mA
Dropout Ground Current	$V_{in}=4.5V$, $I_L=100 \mu A$		110	170		110	170	μA
Current Limit	$V_{om}=0$		150	200		150	200	mA
Thermal Regulation			0.05	0.2		0.05	0.2	%W
Output Noise, 10Hz to 100KHz	$C_L=1 \mu F$		430			430		μV_{rms}
	$C_L=200 \mu F$		160			160		
	$C_L=133 \mu F$		100			100		
	(Bypass=0.01 μF pins 7 to 1 PJ2951)							
8-Pin Versions only		PJ2951A			PJ2951			
Reference Voltage		1.238	1.250	1.262	1.238	1.250	1.262	V
Reference Voltage	Over Temperature (Note 6)	1.19		1.27	1.18		1.28	V
Feedback Pin Bias Current			20	40		20	40	nA
Reference Voltage Temperature Coefficient	(Note 7)		20			50		ppm/°C
Feedback Pin Bias Current Temperature Coefficient			0.1			0.1		nA/°C

150mA Low Dropout Voltage Regulators

APPLICATION HINTS EXTERNAL CAPACITORS

PARAMETER	CONDITIONS (Note 2)	PJ2950A/PJ2951A			PJ2950/PJ2951			UNITS
		Min.	Typ.	Max	Min.	Typ.	Max	
Error Comparator								
Output Leakage Current	$V_{oh}=30V$		0.01	1			1	μA
Output Low Voltage	$V_{in} = 4.5V$ $I_{ol} = 400 \mu A$		150	250		150	250	mV
Upper Threshold Voltage	(Note 8)	40	60		40	60		mV
Power Threshold Voltage	(Note 8)		75	95		75	95	mV
Hysteresis	(Note 8)		15			15		mV
Shutdown Input								
Output Logic Voltage	Low (Regulator ON) High(Regulator OFF)	2	1.3	0.7	2	1.3	0.7	V
Shut down Pin Input Current	$V_s = 2.4V$ $V_s = 30V$		30 450	50 600		30 450	50 600	μA
Regulator Output Current in Shutdown	(Note 9)		3	10		3	10	μA

Note 1: Output or reference voltage temperature coefficients defined as the worst case voltage change divided by the total temperature range.

Note 2: Unless otherwise specified all limits guaranteed for $T_j=25^\circ C$, $V_{in} = 6V, I_L=100 \mu A$ and $C_L=100 \mu F$. Additional conditions for the 8-pin versions are feedback tied to 5V & 3.3V tap output Sense ($V_{out} = 5V$ & 3.3V) and $V_{shutdown} \leq 0.8V$.

Note 3: Regulation is measured at constant junction temperature, using pulse testing with a low duty cycle. Changes in output voltage due to heating effects are covered under the specification for thermal regulation.

Note 4: Line regulation for the PJ2951 is tested at $150^\circ C$ for $I_L=1mA$. For $I_L=100 \mu A$ and $T_j=125^\circ C$, line regulation is guaranteed by design to 0.2%. See typical performance characteristics for line regulation versus temperature and load current.

Note 5: Dropout Voltage is defined as the input to output differential at which the output voltage drops 100mV below its nominal value measured at 1V differential at very low value of programmed output voltage, the minimum input

supply voltage of 2V (2.3V over temperature) must be taken in to account.

Note 6: $V_{ref} \leq V_{out} \leq (V_{in}-1V), 2.3 \leq V_{in} \leq 30V, 100 \mu A \leq I_L \leq 100mA, T_j \leq T_{MAX}$.

Note 7: Output or reference voltage temperature coefficient is defined as the worst case voltage change divided by the total temperature range.

Note 8: Comparator thresholds are expressed in terms of a voltage differential at the feedback terminal below the nominal reference voltage measured at 6V input. To express these thresholds in terms of output voltage change, multiply by the error amplifier gain = $V_{out}/V_{ref} = (R1+R2)/R2$. For example, at a programmed output voltage of 5V, the Error output is guaranteed to go low when the output drops by $95 mV \times 5V/1.250 = 384mV$. Thresholds remain constant as a percent of V_{out} as V_{out} is varied, with the dropout warning occurring at typically 5% below nominal, 7.5% guaranteed.

Note 9: $V_{shutdown} = 2V, V_{in} \leq 30V, V_{out} = 0$, Feedback pin tied to 5V & 3.3V tap.

150mA Low Dropout Voltage Regulators

PROGRAMMING THE OUTPUT VOLTAGE OF PJ2951

External Capacitors

For the stability of the PJ2950/PJ2951 requires a 1.0 μ F or greater capacitor between output and ground. Oscillation could occur without this capacitor. The tantalum or aluminum electrolytic works fine; could use the fILP type but are not cost efficient. For the operation of below -25 $^{\circ}$ C solid tantalum is recommended since the many aluminum type have electrolytes the freeze at about -30 $^{\circ}$ C. The ESR of about 5 Ω or less and resonant frequency above 500KHz are most important parameter in the value of Capacitor. The Capacitors value can be increased without any limit.

At lower values of output current,

less output capacitance is required for stability. For the currents below 10 mA the value of capacitor can be reduce to 0.33 μ F and 0.1 μ F for 1mA. More output capacitance needed for the 8-pin version at voltage below 5V since it runs the error amplifier at lower gain. At worst case 3.3 μ F or greater must be used for condition of 100mA load at 1.250V output .

The PJ2950 not like other low dropout regulators will remain stable and regulation with no load in addition to the internal voltage divider. This feature very important in application like CMOS RAM keep-alive. The PJ2951 output

voltage setting with minimum load of 1 μ A and external resistors.

If at the input of PJ2950/LP 2951 connected to battery or between AC filter capacitor and input is 10 inches wire then 1 μ F tantalum or aluminum electrolytic capacitor should be connected between input and ground .

Instability can occur if stray capacitor to feedback terminal pin 7 of the PJ2951. This could cues more problem more when using higher value of external to set the output voltage . To fix this problem the 100 pF capacitor between output and feedback and increasing output capacitance to 3.3 μ F.

ERROR DETECTION COMPARATOR OUTPUT

The Compactor produces a logic low output whenever the PJ2951 output falls of regulation by more than around 5% . This is around 60 mV offset divided by the 1.250 reference voltage. Thus trip remains 5% below nominal regardless of the programmed output voltage of the regulator . the figure 1 shows the timing diagram depicting the ERROR signal and the regulator output voltage as the PJ2951 input is ramped up and down . the ERROR

signal becomes low at around 1.3 V input , it goes high around 5Volt input , (input voltage at which $V_{out} = 4.75$). The PJ2951 dropout voltage depending on the load , the input voltage trip point around 5 volt will vary with load current. The output voltage trip point is around 4.75 volt it does not change with load.

The error comparator has an open-collector output which requires an external pull-up resistor.

Depending on the system requirement the resistor maybe returned to 5 or 3.3 volt output or other supply voltage depending to the system requirements. For determining the size of the resistor, note that the output is sinking 400 μ A , this value adds to battery drain in a low better condition, recommended values 100K to 1M Ω . If the output is unused this resistor is not required.

150mA Low Dropout Voltage Regulators

The PJ2951 output voltage is programmable for any value from its reference voltage of 1.250 volt and its maximum rating of 30 volt. For example for 5 volt needs to pin-strapped and using the internal voltage divider by tying pin 1 to 2 and pin 7 to pin 6. Refer to Figure 2, there are two external resistor required for this programming.

Refer to the below equation for the programming the output voltage:

$$V_{out} = V_{ref} \times (1 + R_1/R_2) + I_{FB}R_1$$
 The V_{ref} is 1.250 and I_{FB} is the feedback bias current, nominally -20 nA. The minimum recommended load current of $1 \mu A$ forces an upper limit of $1.2M\Omega$ on value of R_2 , if no load presented the I_{FB} produces error of typically 2% in V_{out} which

maybe eliminated at room temperature by trimming R_1 . To improve the accuracy chooses the value of $R_2 = 100K$ and this reduces the error by 0.17% and increases the resistor program current by $12 \mu A$. The PJ2951 typically draw $60 \mu A$ at no load with pin 2 open-circuit, and this value does not look much.

REDUCING OUTPUT NOISE

It could be an advantage to reduce the AC noise present at the output. One way is to reduce the regulator bandwidth by increasing the value of the output capacitor. This is the only method that noise could reduce on the PJ2950 but is relatively inefficient, as increasing capacitor from $1 \mu F$ to $220 \mu F$ only decreases the noise from $430 \mu V$ to $160 \mu V$

rms. for a 100kHz bandwidth at 5 volt output. Noise could be also reduce by fourfold by a bypass capacitor across R_1 since it reduces the high frequency gain from 4 to unity. pick $C_{BYPASS} = 1 / 2\pi R_1 \times 200Hz$ or choose $0.01 \mu F$. When doing this, the output capacitor must be increased to $3.3 \mu F$ to maintain

stability. These changes the output noise from $430 \mu V$ rms. for a 100 kHz bandwidth 5 & 3.3 volt output. With the bypass capacitor added, noise no longer scales with output voltage so that improvements are more dramatic higher output voltage.

FIGURE 1.ERROR OUTPUT TIMING

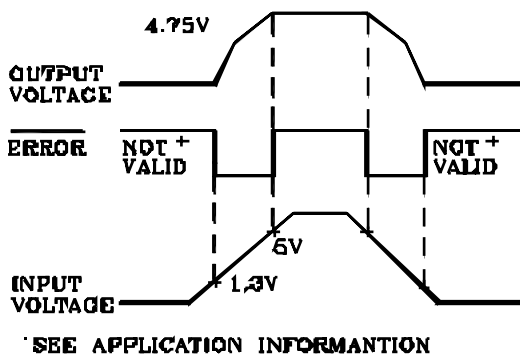
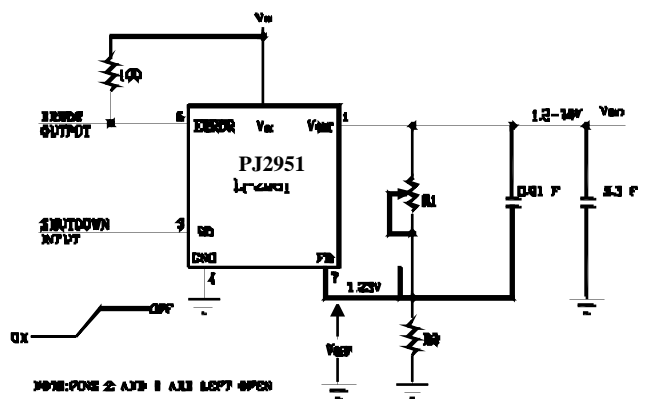
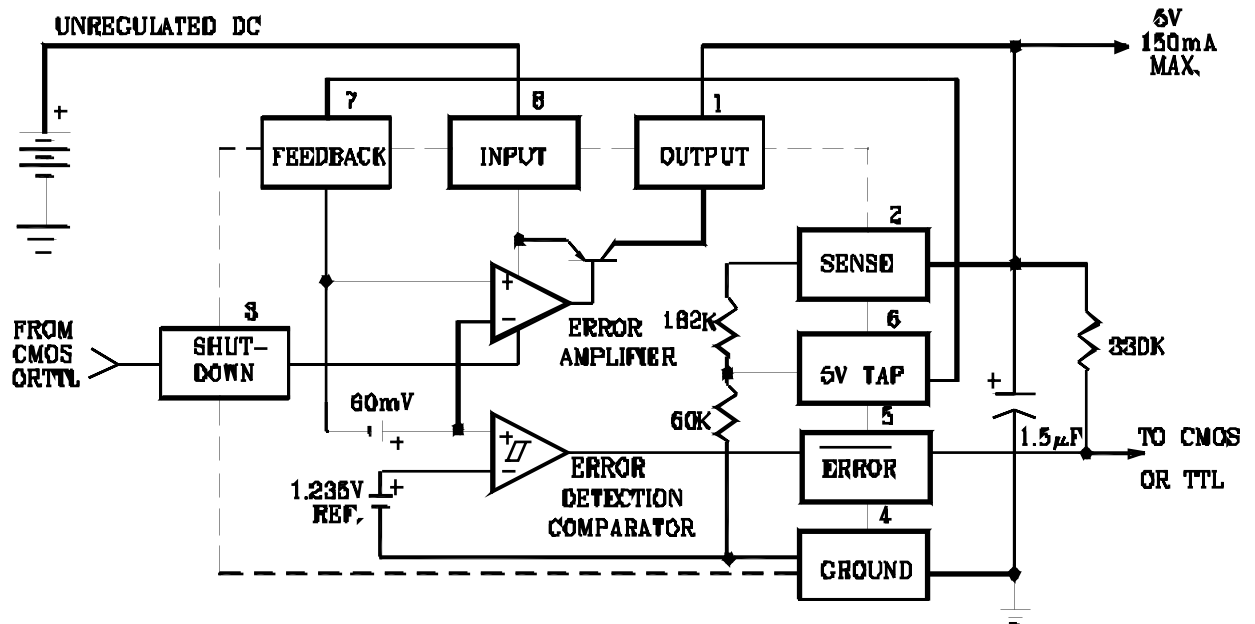

FIGURE 2.ADJUSTABLE REGULATOR



BLOCK DIAGRAM AND TYPICAL APPLICATIONS



150mA Low Dropout Voltage Regulators

SOP-8

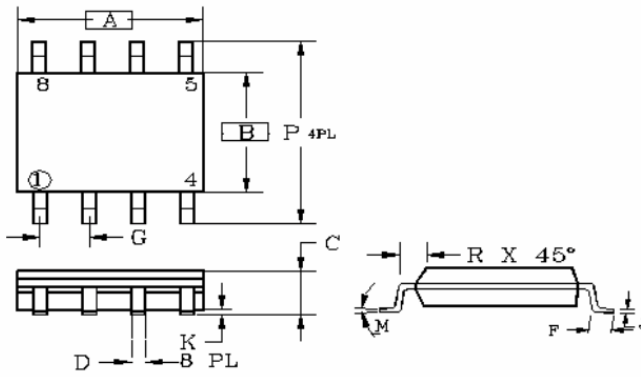

DIM	MILLIMETERS		INCHES	
	MIN	MAX	MIN	MAX
A	4.80	5.00	0.189	0.196
B	3.80	4.00	0.150	0.157
C	1.35	1.75	0.054	0.068
D	0.35	0.49	0.014	0.019
F	0.40	1.25	0.016	0.049
G	1.27BSC		0.05BSC	
K	0.10	0.25	0.004	0.009
M	0°	7°	0°	7°
P	5.80	6.20	0.229	0.244
R	0.25	0.50	0.010	0.019

TO-92 Unit:mm

