

THIS DRAWING IS UNPUBLISHED. RELEASED FOR PUBLICATION, 19 .
 © COPYRIGHT 19 BY AMP INCORPORATED. ALL INTERNATIONAL RIGHTS RESERVED.

LOC	DIST	P	F	ZONE	LTR	DESCRIPTION	DATE	APPD
G	14				H	ADDED 2-35135-2 PER PR 94-6	2/2/94	OKS DAP

METRIC
 DIMENSIONS LISTED IN mm [INCHES]

AMP WIRE RANGE	UL E13288 Listed
12-10 AWG SOLID OR STRANDED	12-10 AWG STRANDED
SR LR7189 Certified	MILITARY P/N AND CLASS
12-10 AWG SOLID OR STRANDED	MS 20659-166 CLASS 2

1 STAMP AMP 12-10* APPROX AS SHOWN

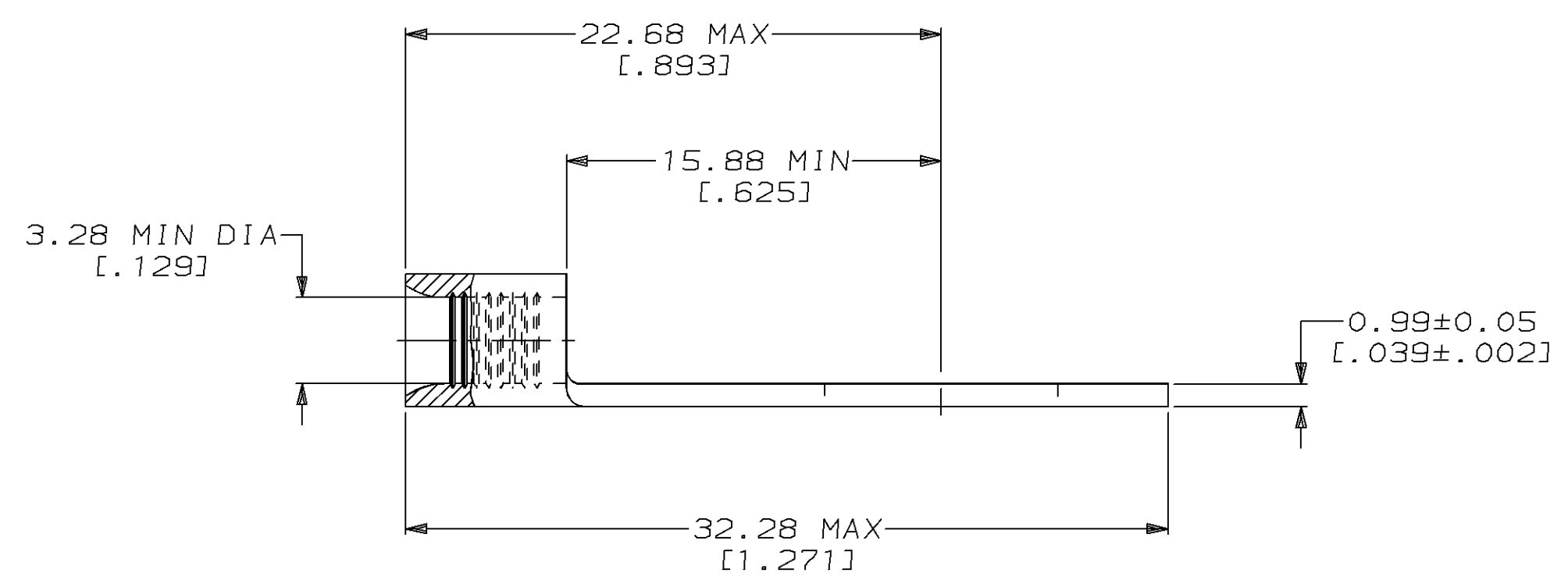
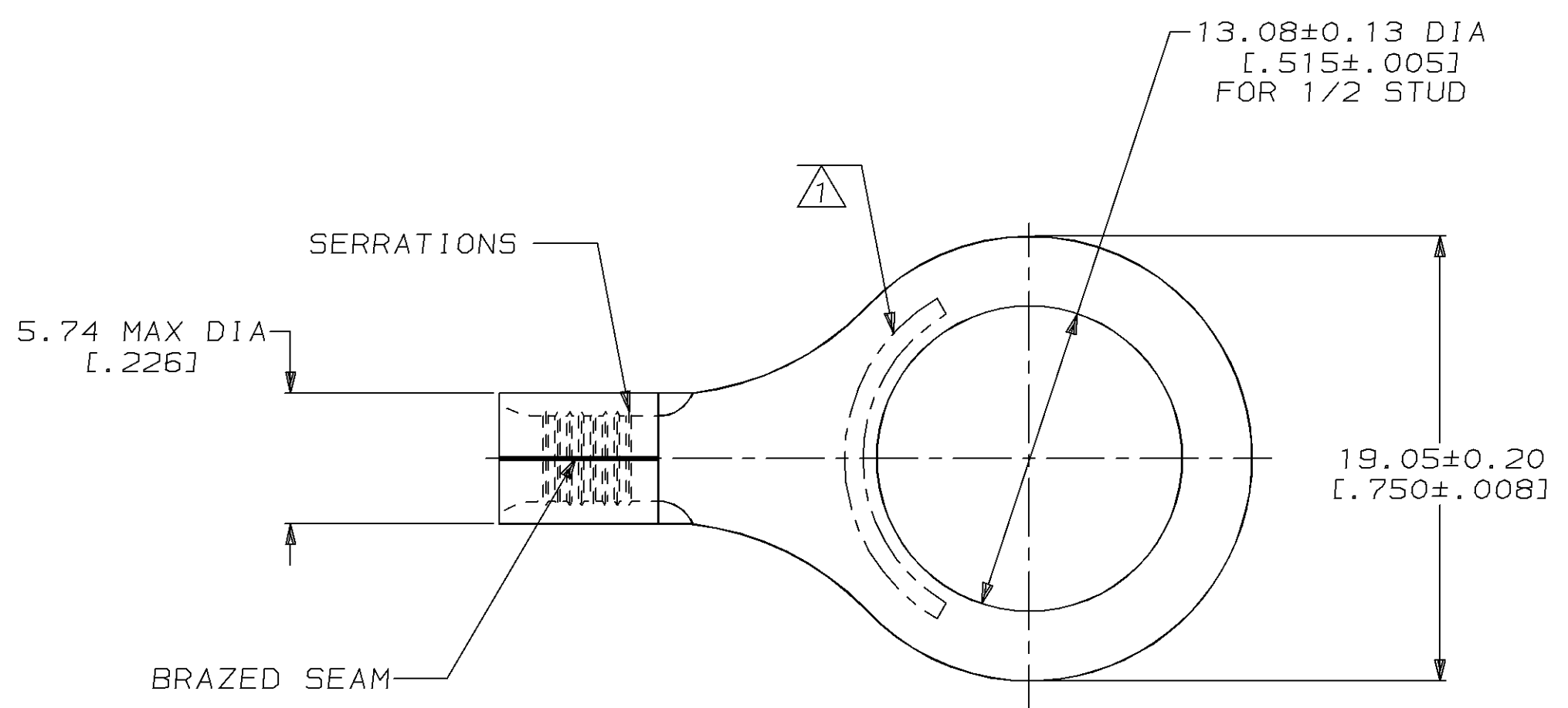

1000	TAPE MOUNTED	2-35135-2
500	LOOSE PIECE	35135
QTY	PACKAGE TYPE	PART NO

AMP INCORPORATED
CUSTOMER SERVICE SYSTEMS

MAX RECOMMENDED OPERATING TEMPERATURE:
 170°C MAX

DO NOT SCALE PRINT. UNLESS SPECIFIED
 DIMENSIONS IN mm [INCHES]
 TOLERANCES ON:
 2 PLC DEC ± -
 3 PLC DEC ± -
 ANGLES ± -

DR 3-17-93
 TA BRINKMAN
 CHK 3-17-93
 DA PATTERSON
 APPD 3-17-93
 DE MILLER
 APPD 3-17-93
 JL MECKLEY
 PRODUCT SPEC -

AMP AMP Incorporated
 Harrisburg, PA 17105-3608

FOR ADDITIONAL PRODUCT INFORMATION OR COPIES OF DRAWINGS AND TECHNICAL DOCUMENTS

PRODUCT INFORMATION CENTER
 1-800-522-6752

VOLTAGE RATING:
 NOT APPLICABLE

MATERIAL
 COPPER PER ASTM B-152 ANNEALED

APPLICATION SPEC -

NAME
TERMINAL, RING TONGUE, SOLISTRAND™

FOR APPLICATION TOOLING INFORMATION

TOOLING ASSISTANCE CENTER
 1-800-722-1111

WIRE CROSS SECTIONAL AREA RANGE:
 2.62-6.64mm² [5,180-13,100] CIR MILS
 SOLID OR STRANDED

FINISH
 TIN PLATE
 0.00254 [0.000100] MIN THK PER MIL-T-10727

WEIGHT -

SIZE CAGE CODE DRAWING NO
 C 00779 C=35135
 SCALE 4:1 SHEET 1 OF 1

THIS DRAWING IS A CONTROLLED DOCUMENT FOR AMP INCORPORATED. IT IS SUBJECT TO CHANGE AND THE CONTROLLING ENGINEERING ORGANIZATION SHOULD BE CONTACTED FOR THE LATEST REVISION.