

**DUAL 4-INPUT SCHMITT TRIGGER**

**DESCRIPTION**

The T74LS13 contains two 4 Input NAND Gates that accept standard TTL input signals and provide standard TTL output levels. They are capable of transforming slowly changing input signals into sharply defined, jitter-free output signals. Additionally, they have a greater noise margin than conventional NAND gates.

Each circuit contains a Schmitt trigger followed by a Darlington level shifter and a phase splitter that drives a TTL totem-pole output. The Schmitt trigger uses positive feedback to effectively speed-up slow input transitions and provide different input threshold voltages for positive and negative-going transitions. This hysteresis between the positive-going and negative-going input thresholds (typically 800 mV) is determined internally by resistor ratios and is essentially insensitive to temperature and supply voltage variations.

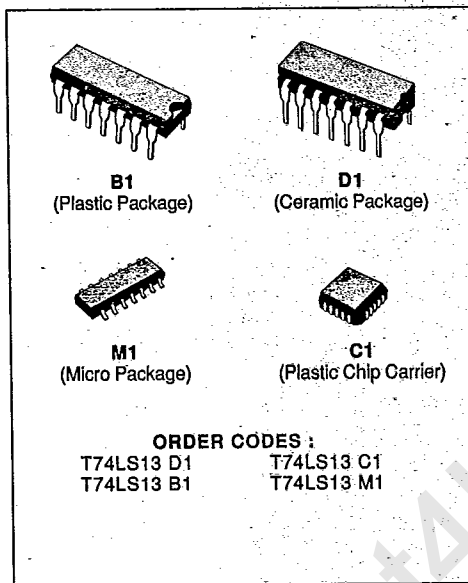

**PIN CONNECTION (top view)**

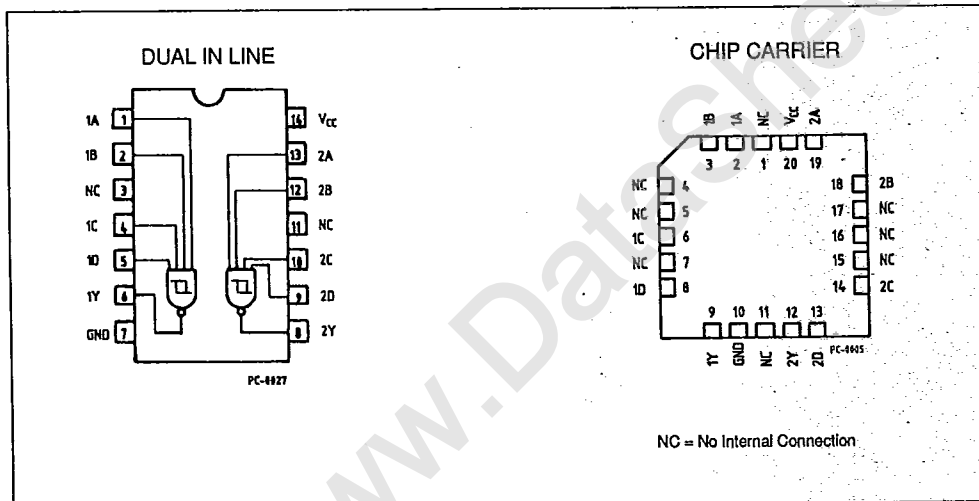

SCHEMATIC

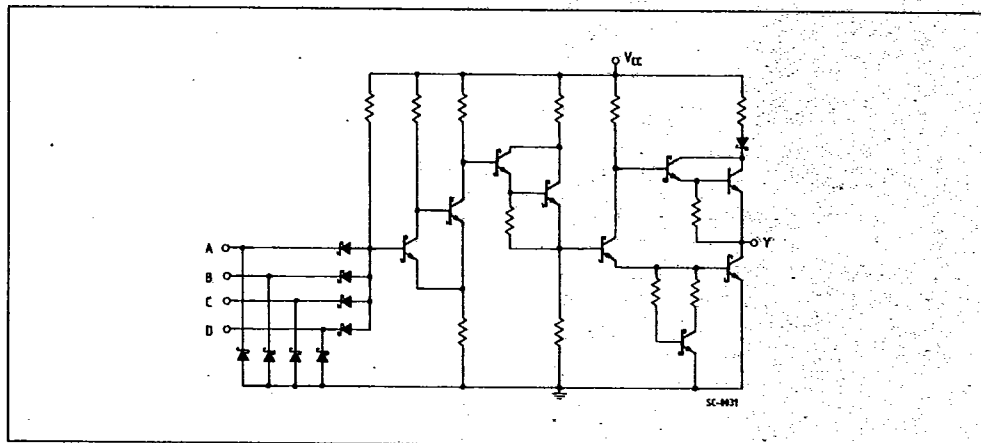

LOGIC DIAGRAM AND TRUTH TABLE

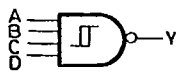

A	B	C	D	Y
L	X	X	X	H
X	L	X	X	H
X	X	L	X	H
X	X	X	L	H
H	H	H	H	L

L = LOW Voltage Level  
 H = HIGH Voltage Level  
 X = Don't Care

ABSOLUTE MAXIMUM RATINGS

Symbol	Parameter	Value	Unit
V <sub>cc</sub>	Supply Voltage	- 0.5 to 7	V
V <sub>i</sub>	Input Voltage, Applied to Input	- 0.5 to 15	V
V <sub>o</sub>	Output Voltage, Applied to Output	- 0.6 to 5.5	V
I <sub>i</sub>	Input Current, Into Inputs	- 30 to 5	mA
I <sub>o</sub>	Output Current, Into Outputs	50	mA

Stresses in excess of those listed under "Absolute Maximum Ratings" may cause permanent damage to the device. This is a stress rating only and functional operation of the device at these or any other conditions in excess of those indicated in the operational sections of this specification is not implied. Exposure to absolute maximum rating conditions for extended periods may affect device reliability.

GUARANTEED OPERATING RANGE

Part Numbers	Supply Voltage			Temperature
	Min.	Typ.	Max.	
T74LS13XX	4.75 V	5.0 V	5.25 V	0 °C to + 70 °C

XX = package type.

S G S-THOMSON 42E D 7929237 0033220 T SGTH

## DC CHARACTERISTICS OVER OPERATING TEMPERATURE RANGE

Symbol	Parameter	Limits			Test Condition (note 1)	Unit	
		Min.	Typ. (*)	Max.			
V <sub>T+</sub>	Positive-going Threshold Voltage	1.5	1.8	2.0	V <sub>CC</sub> = 5.0 V	V	
V <sub>T-</sub>	Negative-going Threshold Voltage	0.6	0.95	1.1	V <sub>CC</sub> = 5.0 V	V	
V <sub>T+</sub> - V <sub>T-</sub>	Hysteresis	0.4	0.8		V <sub>CC</sub> = 5.0 V	V	
V <sub>CD</sub>	Input Clamp Diode Voltage		-0.65	-1.5	V <sub>CC</sub> = MIN, I <sub>IN</sub> = -18 mA	V	
V <sub>OH</sub>	Output HIGH Voltage	2.7	3.4		V <sub>CC</sub> = MIN, I <sub>OH</sub> = -400 μA V <sub>IN</sub> = 0.5 V	V	
V <sub>OL</sub>	Output LOW Voltage		0.25	0.4	I <sub>OL</sub> = 4.0 mA	V <sub>CC</sub> = MIN V <sub>IN</sub> = 1.9 V	V
			0.35	0.5	I <sub>OL</sub> = 8.0 mA		V
I <sub>T+</sub>	Input Current at Positive-going Threshold		-0.14		V <sub>CC</sub> = 5.0 V, V <sub>IN</sub> = V <sub>T+</sub>	mA	
I <sub>T-</sub>	Input Current at Negative-going Threshold		-0.18		V <sub>CC</sub> = 5.0 V, V <sub>IN</sub> = V <sub>T-</sub>	mA	
I <sub>IH</sub>	Input HIGH Current		1.0	20	V <sub>CC</sub> = MAX, V <sub>IN</sub> = 2.7 V V <sub>CC</sub> = MAX, V <sub>IN</sub> = 7.0 V	μA mA	
I <sub>IL</sub>	Input LOW Current			-0.4	V <sub>CC</sub> = MAX, V <sub>IN</sub> = 0.4 V	mA	
I <sub>OS</sub>	Output Short Circuit Current (note 2)	-20		-100	V <sub>CC</sub> = MAX, V <sub>OUT</sub> = 0 V	mA	
I <sub>CCH</sub>	Supply Current HIGH		3	6	V <sub>CC</sub> = MAX, V <sub>IN</sub> = 0 V	mA	
I <sub>CCL</sub>	Supply Current LOW		4	7	V <sub>CC</sub> = MAX, V <sub>IN</sub> = 4.5 V	mA	

Notes : 1. For conditions shown as MIN or MAX, use the appropriate value specified under guaranteed operating ranges.

2. Not more than one output should be shorted at a time.

(\*) Typical values are at V<sub>CC</sub> = 5.0 V, T<sub>A</sub> = 25 °C.AC CHARACTERISTICS : T<sub>A</sub> = 25 °C

Symbol	Parameter	Limits			Test Conditions	Unit
		Min.	Typ.	Max.		
t <sub>PLH</sub>	Turn Off Delay, Input to Output		15	22	V <sub>CC</sub> = 5.0 V C <sub>L</sub> = 15 pF	ns
t <sub>PHL</sub>	Turn On Delay, Input to Output		18	27		ns

Figure 1 :  $V_{IN}$  Versus  $V_{OUT}$  Transfer Function.

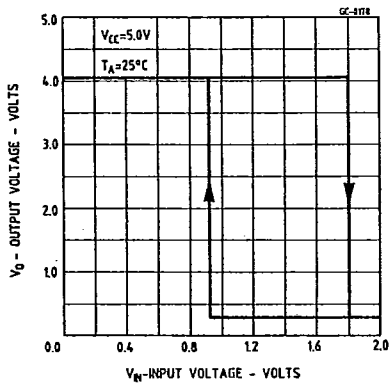

Figure 2: Threshold Voltage and Hysteresis Versus Power Supply Voltage.

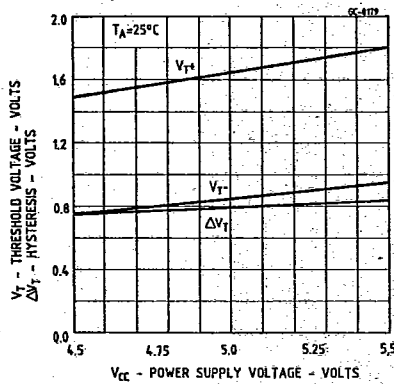

Figure 3: Threshold Voltage and Hysteresis Versus Temperature.

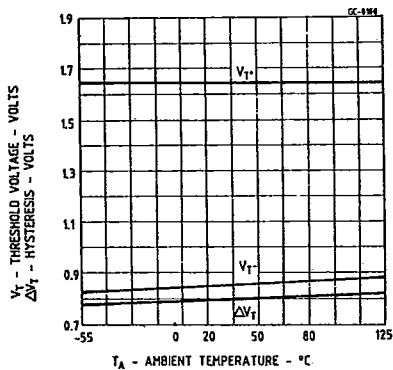

Figure 4.

