



# AC-DC WALL / DESKTOP

**WN 05B (5 Watt Wall Mount AC Adapter)**

(PRELIMINARY INFORMATION)

## Features

- Two pin wall mount type input plug
- Wide range AC input
- Level B EMI filter
- Fully enclosed plastic case
- Fully regulated output
- High efficiency
- High Quality
- Different outputs plugs available



## Electrical specifications

### Input

Voltage ..... 90 - 264 VAC  
 Current ..... 0.4 Arms Max.  
 Frequency ..... 47 - 63 Hz

### Out put

Voltage (Vo) ..... (see table)  
 Tolerance ..... 5%  
 Power (Po) ..... 5 Watt Max.  
 Hold up time ..... 8ms min. at full load, 115 VAC  
 Overvoltage protection ... Build-in  
 Overcurrent protection ... 150% of full load  
 Short circuit protection ... Pulsing mode, auto recovery  
 Efficiency ..... 70% typ. at full load and 115 VAC  
 Ripple/Noise(Vp-p) ..... 1% (20MHz bandwidth)

## Output Electronic Specifications

Model No.	Po	Vo	Io max
WN05-050B	5W	5.0V	1.0A
WN05-090B	5W	9.0V	0.56A
WN05-120B	5W	12.0V	0.42A

## Environmental

### Operating temperature

0 deg. C to +40 deg. C ambient

### Storage temperature

-20 deg. C to +80 deg. C ambient

## EMI

Meet FCC class B, VCCI class B, CISPR 22 class B

## Safety

CE  
TUV

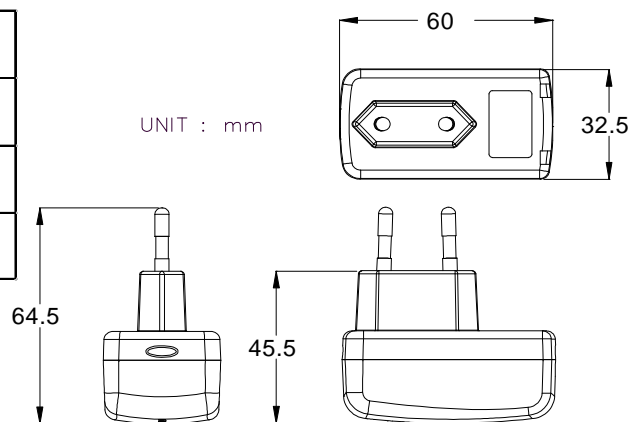

## Power Systems – The Power Solution

Web: [www.Power-Systems.de](http://www.Power-Systems.de)  
 Email: [Info@Power-Systems.de](mailto:Info@Power-Systems.de)

Address: Dörnet 8 ; 74360 Ilsfeld-Auenstein / Germany  
 Tel. : + 49 / 70 62 / 67 59 - 6  
 Fax: + 49 / 70 62 / 67 59 - 80