



GS-BT2416C2

Bluetooth Class 2 Module

Features

- Bluetooth specification V.1.2 compliant
- Supports USB (1.1) /UART/PCM (Pulse Code Modulation) interfaces
- Bluetooth protocol layers support up to HCI
- Output power class 2
- Optimized link manager and control
- Working distance up to 10 meters
- Support wireless LAN coexistence
- 3.3V single supply voltage
- CE Compliant
 - Safety EN60950-1 (2001)
 - EMC EN301 489 17V1.2.1
 - Radio ES 300 328 V1.6.

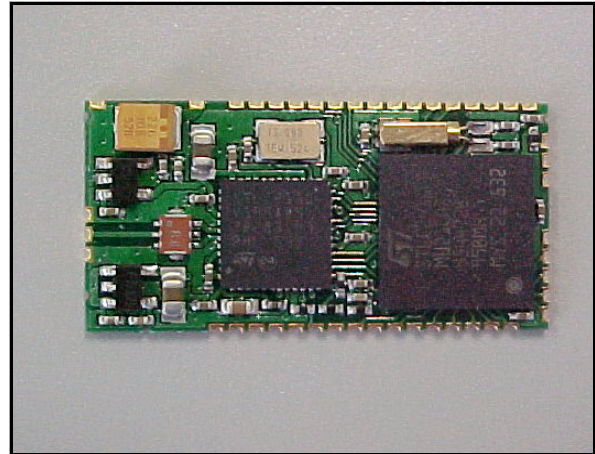

Applications

- Personal computers accessories
- Laptop PCs and accessories
- Hand held devices and accessories
- Internet access points
- Industrial controls

Order code

- GS-BT2416C2

Description

SPG Bluetooth Class 2 Module is a highly integrated module for fast implementation in various applications to enable electronic devices to communicate wirelessly with other Bluetooth enabled devices.

It is a true saver for manufacturers to provide time-to-market products.

With different types of interface, (USB/UART/PCM/SPI/I²C), the module can be used in applications such as Notebook PCs and accessories, PDA, Access Points, Headphones and PC peripherals, etc.

Contents

1	Maximum ratings	3
1.1	Absolute maximum ratings	3
1.2	Operating ranges	3
2	I/O specification	4
3	Bluetooth section	4
4	Block diagram	5
5	Pin settings	6
6	Mechanical dimensions	8
7	Revision history	9

www.DataSheet4U.com



1 Maximum ratings

1.1 Absolute maximum ratings

Operation of the module beyond these limits is not guaranteed.

Sustained exposure to these limits will adversely affect device reliability.

Table 1. Absolute maximum ratings

Symbol	Parameter	Values		Unit
		Min	Max	
V _{DD}	Module supply voltage		4	V
V _{IN}	Input voltage on any digital pin	V _{ss} -0.5	V _{dd} +0.3	V
T _{stg}	Storage temperature	-40	+85	°C
T _{sold}	Soldering temperature		240	

1.2 Operating ranges

Operating ranges define the limits for functional operation and parametrics characteristics of the module.

Functionality outside these limits is not implied

Table 2. Operating ranges

Symbol	Parameter	Conditions	Values			Unit
			Min	Typ	Max	
V _{DD}	Module supply voltage	-20°C < T < 70 °C	3.13	3.3	3.47	V
T _{stg}	Operating ambient temperature		-20		+70	°C

2 I/O specification

Table 3. DC Input / Output specification

Symbol	Parameter	Conditions	Values			Unit
			Min	Typ	Max	
V_{il}	Low level input voltage	$3.13\text{ V} < V_{DD} < 3.47\text{ V}$			0.8	V
V_{ih}	High level input voltage	$3.13\text{ V} < V_{DD} < 3.47\text{ V}$	2			V
V_{hyst}	Schmitt trigger hysteresis	$3.13\text{ V} < V_{DD} < 3.47\text{ V}$	0.4			V
V_{ol}	Low level output voltage	Io load = pin drive capability			0.15	V
V_{oh}	High level output voltage	Io load = pin drive capability	$V_{DD} - 0.15$			V

3 Bluetooth section

Table 4. Bluetooth section

Symbol	Parameter	Conditions	Values			Unit
			Min	Typ	Max	
P_{tr}	Transmission power	$3.13\text{ V} < V_{DD} < 3.47\text{ V}$		2		dBm
Sens	Sensitivity	$3.13\text{ V} < V_{DD} < 3.47\text{ V}$	-70			dBm
Flim	Frequency limit	$3.13\text{ V} < V_{DD} < 3.47\text{ V}$	2402		2480	MHz
CHs	channel space			1		MHz
Hop	Hopping			1600		hops/sec
RF ck	RF crystal oscillator			13		MHz
BB ck	Baseband crystal oscillator	C2		32		kHz
Tra	Transmission rate asynchronous				721	kbits/sec
Trs	Transmission rate synchronous				432	kbits/sec
Iop	Operation current TX mode			90		mA
	Operation current RX mode			50		mA

4 Block diagram

Figure 1. Block diagram

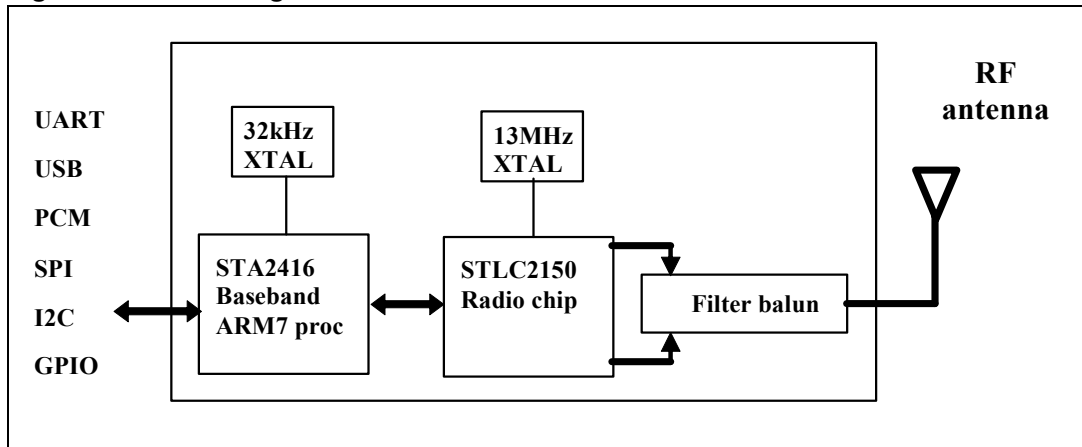

www.DataSheet4U.com

5 Pin settings

Table 5. Pin description

Pin N°	Name	I/O	Description
1	TDI		JTAG pin
2	TMS		JTAG pin
3	NTRST		JTAG pin
4	TDO		JTAG pin
5	TCK		JTAG pin If not used connect to VSS1
6	INT1	I	External Interrupt signal Internally connected to VSS1 with 10 K Ω If not used connect to VSS1
7	I2C_dat	I/O	I2C bus interface data To be connected to VDD with 10 K Ω resistor
8	I2C_clk	I/O	I2C bus interface clock To be connected to VDD with 10 K Ω resistor
9	PCM_CLK	I/O	PCM clock
10	PCM_SYNC	I/O	PCM 8kHz synch
11	PCM_B	I/O	PCM Data In/Out
12	PCM_A	I/O	PCM Data In/Out
13	UART2_RXD	I	UART2 data input If not used connect to VDD
14	UART2_TXD	O	UART2 data output
15	UART2_I1	O/I	UART2 clear to send input If not used connect to VDD
16	UART2_O2	O	UART1 ready to send output
17	SPI_FRM	I/O	Synchronous Serial Interface frame synch
18	SPI_CLK	I/O	Synchronous Serial Interface clock
19	SPI_TXD	O/T	Synchronous Serial Interface transmit data
20	SPI_RXD	I	Synchronous Serial Interface receive data If not used connect to VSS1
21	USB_DN	I/O	USB data - If not used connect to VSS1
22	USB_DP	I/O	USB data + If not used connect to VSS1
23	RESET	I	Reset pin (active low)
24	BOOT	I	External downloading Enable (active low) Internally pul-upped to 1.8V by 10kohm
25	GPIO0	I/O	General purpose I/O line

Table 5. Pin description (continued)

Pin N°	Name	I/O	Description
26	GPIO1	I/O	General purpose I/O line
27	GPIO2	I/O	General purpose I/O line
28	GPIO3	I/O	General purpose I/O line
29	GPIO4	I/O	General purpose I/O line
30	GPIO5	I/O	General purpose I/O line
31	GPIO6	I/O	General purpose I/O line
32	GPIO7	I/O	General purpose I/O line
33	GPIO8	I/O	General purpose I/O line
34	GPIO9	I/O	General purpose I/O line
35	LP CLOCK OUT	--	32 kHz - out
36	GPIO11	I/O	General purpose I/O line
37	GPIO12	I/O	General purpose I/O line
38	GPIO13	I/O	General purpose I/O line
39	GPIO14	I/O	General purpose I/O line
40	GPIO15	I/O	General purpose I/O line
41	Vdd	--	Module supply voltage- Single 3.3V
42	Vss1	--	GND
43	Vss2 (RF GND)	--	RF GND
44	+ANTENNA	--	Antenna out
45	Vss2 (RF GND)	--	RF GND

www.DataSheet4U.com

6 Mechanical dimensions

Figure 2. Mechanical dimensions

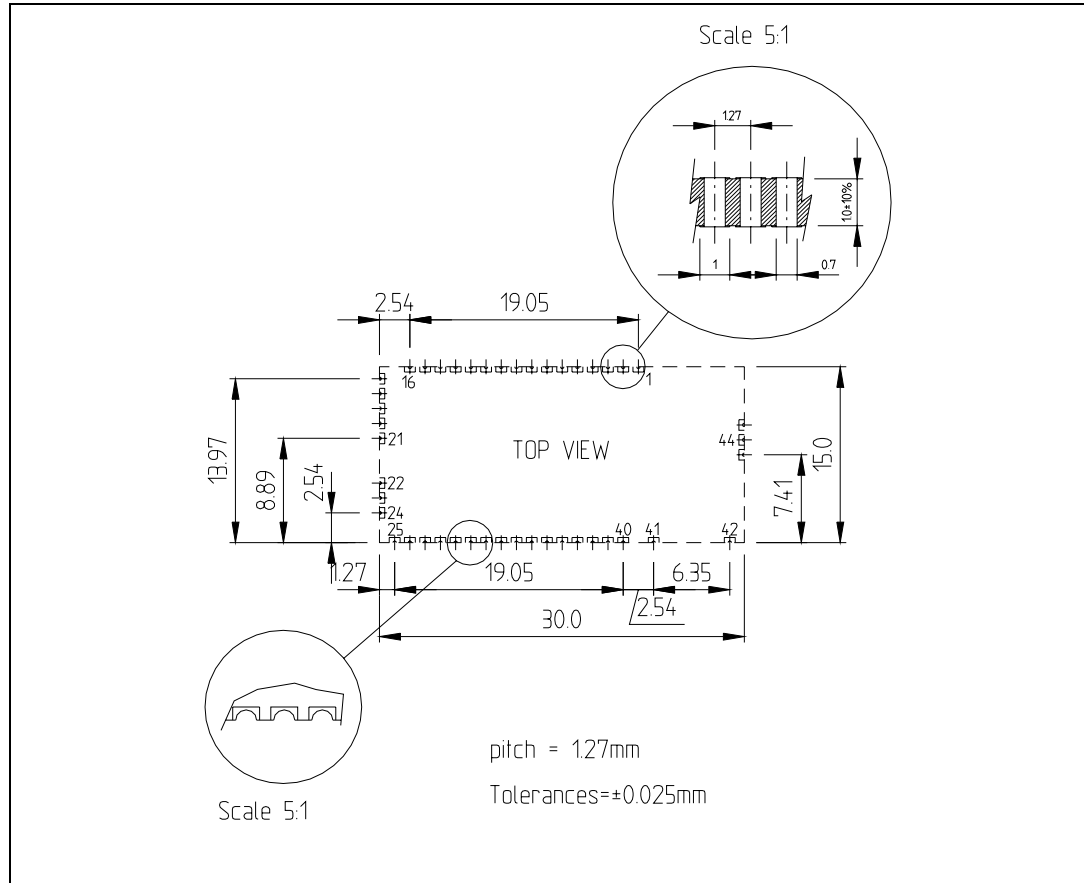
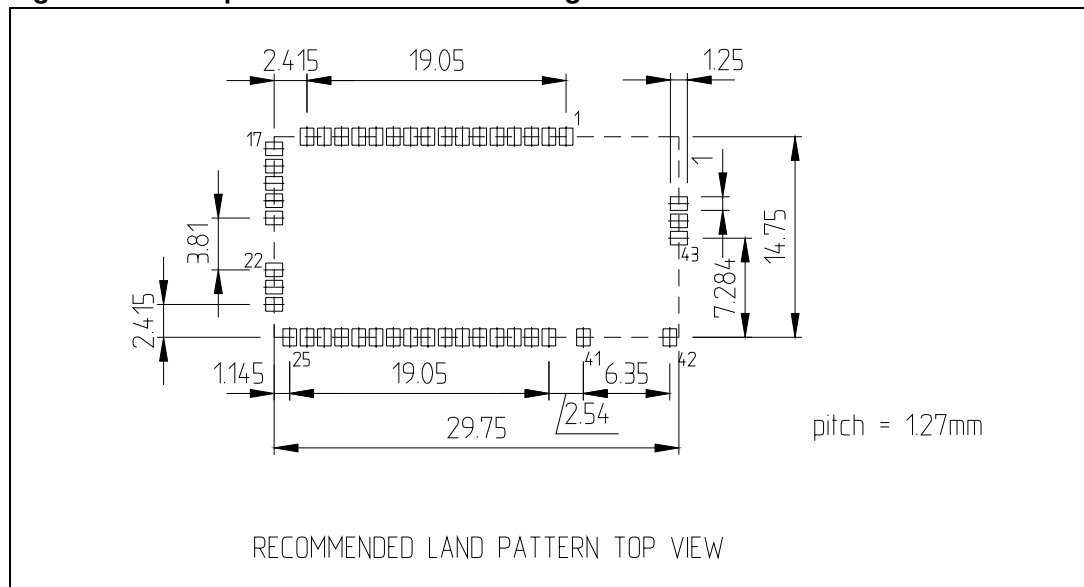

Figure 3. Land pattern and connection diagram



7 Revision history

Table 6. Revision history

Date	Revision	Changes
20-Dec-2006	1	First release
28-Feb-2007	2	Typo Table 5: Pin description on page 6

Please Read Carefully:

Information in this document is provided solely in connection with ST products. STMicroelectronics NV and its subsidiaries ("ST") reserve the right to make changes, corrections, modifications or improvements, to this document, and the products and services described herein at any time, without notice.

All ST products are sold pursuant to ST's terms and conditions of sale.

Purchasers are solely responsible for the choice, selection and use of the ST products and services described herein, and ST assumes no liability whatsoever relating to the choice, selection or use of the ST products and services described herein.

No license, express or implied, by estoppel or otherwise, to any intellectual property rights is granted under this document. If any part of this document refers to any third party products or services it shall not be deemed a license grant by ST for the use of such third party products or services, or any intellectual property contained therein or considered as a warranty covering the use in any manner whatsoever of such third party products or services or any intellectual property contained therein.

UNLESS OTHERWISE SET FORTH IN ST'S TERMS AND CONDITIONS OF SALE ST DISCLAIMS ANY EXPRESS OR IMPLIED WARRANTY WITH RESPECT TO THE USE AND/OR SALE OF ST PRODUCTS INCLUDING WITHOUT LIMITATION IMPLIED WARRANTIES OF MERCHANTABILITY, FITNESS FOR A PARTICULAR PURPOSE (AND THEIR EQUIVALENTS UNDER THE LAWS OF ANY JURISDICTION), OR INFRINGEMENT OF ANY PATENT, COPYRIGHT OR OTHER INTELLECTUAL PROPERTY RIGHT.

UNLESS EXPRESSLY APPROVED IN WRITING BY AN AUTHORIZED ST REPRESENTATIVE, ST PRODUCTS ARE NOT RECOMMENDED, AUTHORIZED OR WARRANTED FOR USE IN MILITARY, AIR CRAFT, SPACE, LIFE SAVING, OR LIFE SUSTAINING APPLICATIONS, NOR IN PRODUCTS OR SYSTEMS WHERE FAILURE OR MALFUNCTION MAY RESULT IN PERSONAL INJURY, DEATH, OR SEVERE PROPERTY OR ENVIRONMENTAL DAMAGE. ST PRODUCTS WHICH ARE NOT SPECIFIED AS "AUTOMOTIVE GRADE" MAY ONLY BE USED IN AUTOMOTIVE APPLICATIONS AT USER'S OWN RISK.

Resale of ST products with provisions different from the statements and/or technical features set forth in this document shall immediately void any warranty granted by ST for the ST product or service described herein and shall not create or extend in any manner whatsoever, any liability of ST.

ST and the ST logo are trademarks or registered trademarks of ST in various countries.

Information in this document supersedes and replaces all information previously supplied.

The ST logo is a registered trademark of STMicroelectronics. All other names are the property of their respective owners.

© 2007 STMicroelectronics - All rights reserved

STMicroelectronics group of companies

Australia - Belgium - Brazil - Canada - China - Czech Republic - Finland - France - Germany - Hong Kong - India - Israel - Italy - Japan - Malaysia - Malta - Morocco - Singapore - Spain - Sweden - Switzerland - United Kingdom - United States of America

www.st.com