

FEATURES

- 700 - 3000 MHz
- 60 dB Isolation
- TTL Driver
- 45 nSec Switching Speed
- SMA Connectors



**MODEL NO.
CDS0979**

PIN Diode SP2T

SP2T

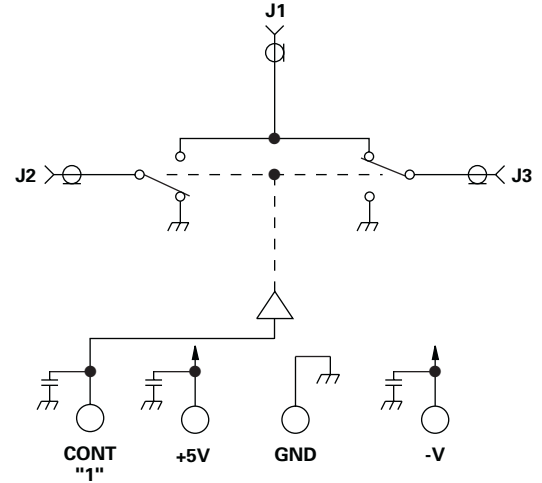
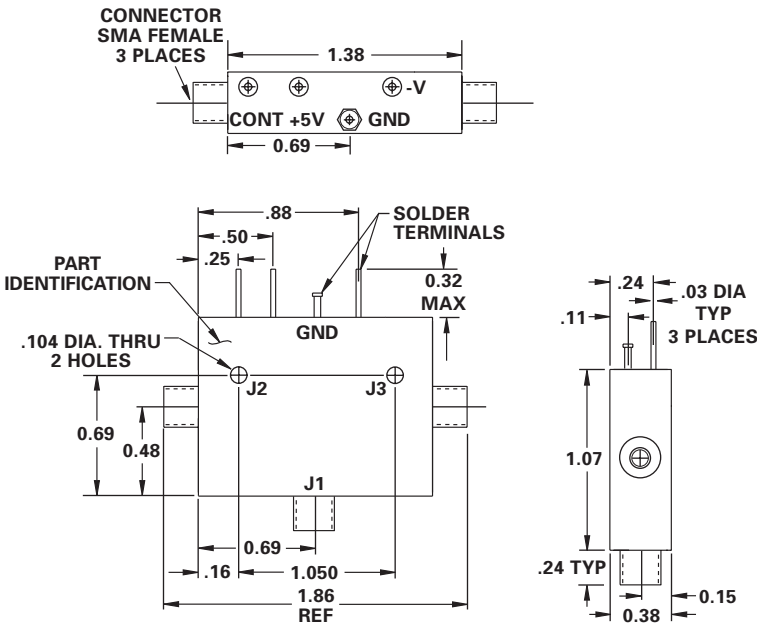

GUARANTEED PERFORMANCE

Parameter	Min	Typ	Max	Units	Conditions
Operating Frequency	700		3000	MHz	
DC Current		18	25	mA	At +5 VDC Supply
		7	15	mA	At -12 to -15 VDC Supply
Control Type		TTL			1 Line Logic "1" = J1 - J3
Control Current	High	1	±40	µA	V _{IH} = +2.7V
	Low	1	±40	µA	V _{IL} = +0.5V
Insertion Loss		0.8	1.2	dB	
Isolation		55	61	dB	
VSWR	Thru	1.15/1	1.3/1		
Impedance		50		OHMS	
Switching Speed		45	100	nSEC	50% TTL to 10% / 90% RF
Transition (Rise/Fall) Time		25		nSEC	10% / 90% or 90% / 10% RF
Switching (Video) Transients		2.8		V	Peak
Intercept Points	2nd	+70		dBm	500 MHz / 400 MHz
	3rd	+43		dBm	250 MHz / 400 MHz
RF Power	Operate	+34	+27	dBm	0.1 dB Compression
	No Damage		+33	dBm	
Operating Temperature	-55	+25	+85	°C	TA

