

# HITACHI

Aug. 03, 2001

KAOHSIUNG HITACHI  
ELECTRONICS CO.,LTD  
P.O. BOX 26-27  
2,13TH EAST ST. K.E.P.Z.  
KAOHSIUNG TAIWAN R.O.C.  
TEL:(07) 8211101(10 LINE)  
FAX:(07) 821-5860

No. 7B4LTD – 2122 -1

## LIQUID CRYSTAL DISPLAY MODULE TECHNICAL DATA

### **SX09Q002-BZA**

#### C O N T E N T S

No.	ITEM	SHEET No.	PAGE
1	COVER	7B64LTD2122 – SX09Q002-BZA-1	1-1/1
2	RECORD OF REVISION	7B64LTD2122 – SX09Q002-BZA-1	2-1/1
3	MECHANICAL DATA	7B64LTD2122 – SX09Q002-BZA-1	3-1/1
4	ABSOLUTE MAXIMUM RATINGS	7B64LTD2122 – SX09Q002-BZA-1	4-1/1
5	ELECTRICAL CHARACTERISTICS	7B64LTD2122 – SX09Q002-BZA-1	5-1/3~5-3/3
6	OPTICAL CHARACTERISTICS	7B64LTD2122 – SX09Q002-BZA-1	6-1/3~6-3/3
7	BLOCK DIAGRAM	7B64LTD2122 – SX09Q002-BZA-1	7-1/1
8	INTERFACE TIMING CHART	7B64LTD2122 – SX09Q002-BZA-1	8-1/6~8-6/6
9	DIMENSIONAL OUTLINE	7B64LTD2122 – SX09Q002-BZA-1	9-1/1
10	APPEARANCE STANDARD	7B64LTD2122 – SX09Q002-BZA-1	10-1/5~10-5/5
11	PRECAUTION IN DESIGN	7B64LTD2122 – SX09Q002-BZA-1	11-1/3~11-3/3
12	DESIGNATION OF LOT MARK	7B64LTD2122 – SX09Q002-BZA-1	12-1/2~12-2/2
13	PRECAUTION FOR USE	7B64LTD2122 – SX09Q002-BZA-1	13-1/1

#### (NOTE)

1. This document may, wholly or partially, be subject to change without notice.
2. All rights are reserved ; No one is permitted to reproduce or duplicate, in any form, the whole or part of this document without Hitachi's permission.
3. No one is permitted to reveal the contents of this document to any third parties without Hitachi's permission.
4. Hitachi shall not be held responsible for any damage to the user that may result from accidents or any other reasons during operation of the user's unit according to this document, any previous reports or oral discussions.
5. Circuit drawings and other examples described herein are meant merely to indicate the characteristics and performance of Hitachi's products. Hitachi assumes no responsibility for any intellectual property claims or other problems that may result from applications based on the examples described herein.
6. No license is granted by implication or otherwise under any patents or other rights of any third party or Hitachi, Ltd.
7. LIFE SUPPORT APPLICATIONS : Hitachi's products are not authorized for use in LIFE SUPPORT SYSTEMS.

## RECORD OF REVISION

DATE	SHEET No.	SUMMARY

### 3.MECHANICAL DATA

(1) Part Name	SX09Q002-BZA
(2) Module Size	92.1(W)mmx71.0(H)mmx9.0max(D)mm
(3) Dot Pitch	0.077(W)mmx0.231(H)mm
(4) Number of Dots	320x3(R,G,B))(W)x240(H) dots
(5) Duty Ratio	1/245
(6) LCD Type	Color STN Transmissive type
(7) Viewing Direction	6 O'clock
(8) Backlight	Cold Cathode Fluorescent Tube (CFL) x 1
(9) Power Consumption(Total)	(323mW) Except inverter
(10) Weight	(68g)
(11) Power Supply Voltage	3.3V only
(12) Touch Panel	Resistance Type The surface is glare type

#### 4. ABSOLUTE MAXIMUM RATINGS

##### 4.1 ELECTRICAL ABSOLUTE MAXIMUM RATINGS OF LCD

VSS=0V

ITEM	SYMBOL	MIN.	MAX.	UNIT	COMMENT
Power Supply for Logic	VDD	0	4.0	V	
Power Supply for LCD (common)	VCON	0	VDD	V	
Input Voltage	Vi	-0.3	VDD+0.3	V	Note 1
Input Current	li	0	1	A	
Static Electricity	-	-	(± 8)	kV	Note 2

Note (1):  $\overline{\text{DISP}} \bullet \text{OFF}, \text{FLM}, \text{CL1}, \text{CL2}, \text{D0} \sim \text{D7}$ .

Note (2): 200pF-250Ω 25°C - 70%RH, The surface of metal bezel and LCD panel are subjected.

##### 4.2 ENVIRONMENTAL ABSOLUTE MAXIMUM RATINGS

I T E M	OPERATING		STORAGE		COMMENT
	MIN.	MAX.	MIN.	MAX.	
Ambient temperature	5°C	40°C	-20°C	60°C	Note 2,3,6
Humidity	Note 1		Note 1		Without condensation
Vibration	-	2.45m/s <sup>2</sup>	-	11.76m/s <sup>2</sup> Note 5	Note 4,7
Shock	-	29.4m/s <sup>2</sup>	-	490m/s <sup>2</sup> Note 5	XYZ directions Note 7
Corrosive Gas	Not Acceptable		Not Acceptable		

Note (1) Ta ≤ 40°C : 85%RH max.

Ta > 40°C : Absolute humidity must be lower than the humidity of 85%RH at 40°C.

Note (2) Ta at -20°C for 48h, at 60°C for 168h.

Note (3) Background color changes slightly depending on ambient temperature  
This phenomenon is reversible.

Note (4) 5Hz~100Hz(Except resonance frequency)

Note (5) This LCM will resume normal operation after finishing the test.

Note (6) The response time will be slower at 5°C

Note (7) The module has no mounting hole.

it should be fixed by the way of sandwiching-like method. (Fig.1)

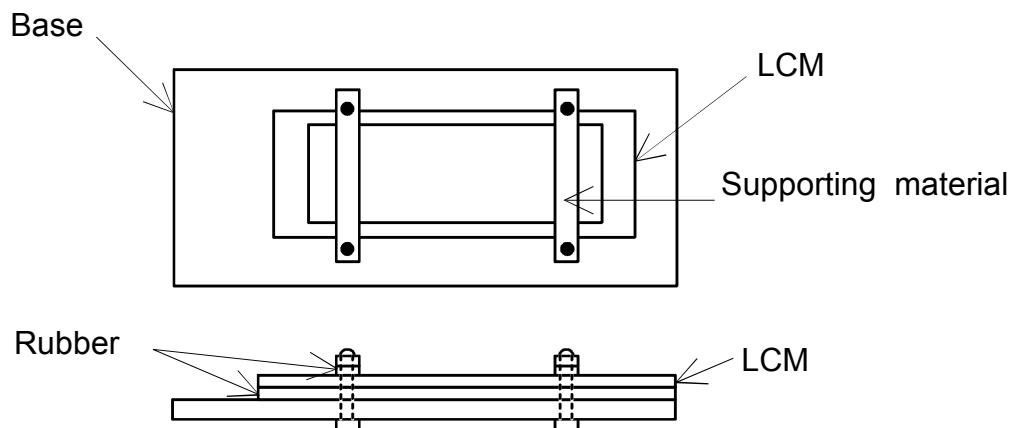

Fig.1

## 5. ELECTRICAL CHARACTERISTICS

### 5.1 ELECTRICAL CHARACTERISTICS OF LCD

I T E M	SYMBOL	CONDITION	MIN.	TYP.	MAX.	UNIT
Power Supply Voltage	VDD	-	3.15	3.30	3.45	V
Contrast Adjustment Voltage (Note 1)	VCON	-	1	-	VDD	V
Input Voltage for Logic Circuits (Note 2)	VI	"H" level	0.8VDD	-	VDD	V
		"L" level	0	-	0.2VDD	
Power Supply Current (Note 3)	IDD	VDD-VSS=3.3V	-	(4)	(8)	mA
Input Leak Current	I <sub>con</sub> (Note4)	V <sub>con</sub> =1~VDD	-	-	± 10	μA
	I <sub>in</sub> (Note2)	V <sub>in</sub> =VDDorVSS	-	-	± 5.0	
Contrast Adjustment Voltage (Note 5)	VCON	Ta= 5°C , φ=0°	-	(2.1)	(2.5)	V
		Ta=25°C , φ=0°	(1.6)	2.0	(2.4)	
		Ta=40°C . φ=0°	(1.3)	(1.7)	-	
Frame Frequency (Note 6)	fFLM	-	60	70	100	Hz

(Note 1) The brightness will increase with decreasing contrast adjustment voltage.

(Note 2) DISP • OFF ,FLM ,CL1 ,CL2 ,D0~D7.

(Note 3) fFLM=70Hz Ta=25°C, Pattern used as display pattern : All white.

(Note 4) VCON

(Note 5) fFLM=70Hz , Duty=1/245

The Contrast Adjustment Voltage is specified as (2.0± 0.4)V under the condition that optimum contrast is obtained by naked eyes with a "Q" test pattern.

(Note 6) Please set the frame frequency so as to avoid flicker and ripples on the display.

(Note 7) Some points for attention while setting driving condition of appliance

(1) Frame Frequency

Please set the frame frequency as the typical value (central vale) which in CAS. According to the characteristic or response time of LC material, that setting the frame frequency near the minimum value or under the minimum value shown in CAS will cause a frame with moving phenomenon.

(2) Setting value Vcon

Vcon, adjusted to get the best contrast ratio of LCD module, is adjusted to be distributed within the tolerance +/-0.4V of central value in CAS before LCD modules ship the factory.

The below items are recommended at customer side.

(i) When designing the appliance, please set the Vcon value as an adjustable value.

(ii) And the Vcon value must be able to be adjusted to match most suitable Vcon to get the best contrast ratio. A fixed Vcon value a little different from the most suitable Vcon value of LCD module and causes a misjudgment.

(iii) The Vcon adjustment(when D/A [Digital/Analogue] converter is used) is recommended to be set as 50mV at most per step. That one step is more than 50mV may cause the input value to be not able match the most suitable value.

The characteristic of contrast ratio can not present absolutely.

## 5.2 ELECTRICAL CHARACTERISTICS OF TOUCH PANEL

### 5.2.1 OPERATING CONDITION

ITEM	SPECIFICATION
Operating Voltage	5VDC max
Operating Current	T.B.D

### 5.2.2 ELECTRICAL CHARACTERISTICS

ITEM	SPECIFICATION	NOTE
Resistance Between terminal	X1-X2	180~1070Ω
	Y1-Y2	150~850Ω
Insulance Resistance	X-Y	10MΩ min.
Linearity	X	1.5% max.
	Y	1.5% max.
Chattering	15ms max.	

### 5.2.3 MECHANICAL CHARACTERISTICS

ITEM	SPECIFICATION	NOTE
Pen input pressure	1.0N max	R0.8mm polyacetal pen
Surface hardness	2H min.	JIS K5400

### 5.2.4

(Note 1)

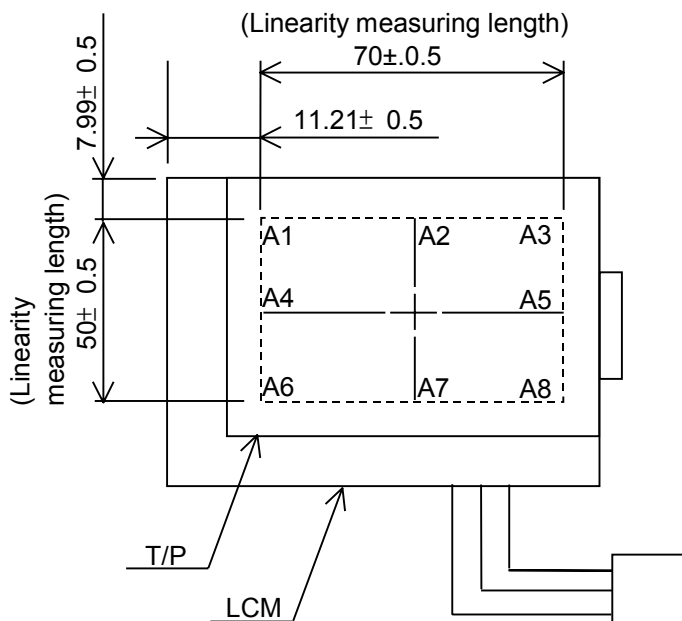

(Measuring method)

$$\text{Linearity}(\%) = \frac{\Delta V}{EV-SV} \times 100$$

$\Delta V$  : The difference between the ideal voltage and measured voltage on the each measuring line.

SV : Voltage of Starting Points  
(X axis:A1,A4,A6, Y axis:A1,A2,A3)

EV : Voltage of Ending Points  
(X axis:A3,A5,A8, Y axis:A6,A7,A8)

Measuring line X axis:A1-A3,A4-A5,A6-A8  
Y axis:A1-A6,A2-A7,A3-A8

### 5.3 ELECTRICAL CHARACTERISTICS OF BACKLIGHT

ITEM	SYMBOL	MIN	TYP	MAX	UNIT	NOTE
Lamp Voltage	VL	-	(310)	-	Vrms	Ta=25°C
Frequency	fL	(50)	(60)	-	kHz	
Lamp Current (1Lamp)(Note 7)	IL	(0.8)	(1.0)	(2.0)	mA	Ta=25°C
Starting discharge Voltage	VS (Note 2)	(1000)	-	-	Vrms	Ta=5°C

(Note 1) Please design your lamp driving circuit (inverter) according to the above specifications, and inform Hitachi of it.

(Note 2) Starting discharge voltage is increased when LCM is operating at low temperature.

Please check the characteristics of your inverter before applying to your set.

(Note 3) Average life time of CFL will be decreased when LCM is operating at low temperature.

(Note 4) Under lower driving frequency of an inverter, a certain backlight system (CFL & CFL reflection sheet) may generate a sound noise. Before designing the inverter, please consider the driving frequency and noise.

(Note 5) When IL is over 2.0mA, it may cause uneven contrast near CFL location, due to heat dispersion form CFL.

(Note 6) The brightness of the CFL in this LCM may deteriorate after the long-hour use under ICFL=1.0mA. However, it will recover when the CFL is lighted at ICFL=2.0mA min. 5minutes or more.

(Note 7) We recommend to equip protection circuit (TO stop output) which works under abnormal operation to the inverter for CFL.

## 6. OPTICAL CHARACTERISTICS

### 6.1 OPTICAL CHARACTERISTICS OF LCD

Ta=25°C (Backlight on)

ITEM	SYMBOL	CONDITION	MIN.	TYP.	MAX.	UNIT	NOTE	
Viewing area	$\phi 2 - \phi 1$	$\theta = 0^\circ, K \geq 2.0$	-	(60)	-	deg	1,2	
		$\theta = 90^\circ, K \geq 2.0$	-	(60)	-	deg	1,2	
Contrast ratio	K	$\phi = 0^\circ, \theta = 0^\circ$	(20)	(30)	-	-	3,5,6	
Response time (rise+fall)	tr+tf	$\phi = 0^\circ, \theta = 0^\circ$	-	(300)	-	ms	4	
Color tone (Primary Color)	Red	x	$\phi = 0^\circ, \theta = 0^\circ$	-	T.B.D	-	-	7
		y		-	T.B.D	-	-	
	Green	x		-	T.B.D	-	-	
		y		-	T.B.D	-	-	
	Blue	x		-	T.B.D	-	-	
		y		-	T.B.D	-	-	
	White	x		-	T.B.D	-	-	
		y		-	T.B.D	-	-	

(Measurement condition : Hitachi standard)  
Note 1)~7) : See next page.



Note 1. Definition of  $\theta$  and  $\phi$   
(Normal)

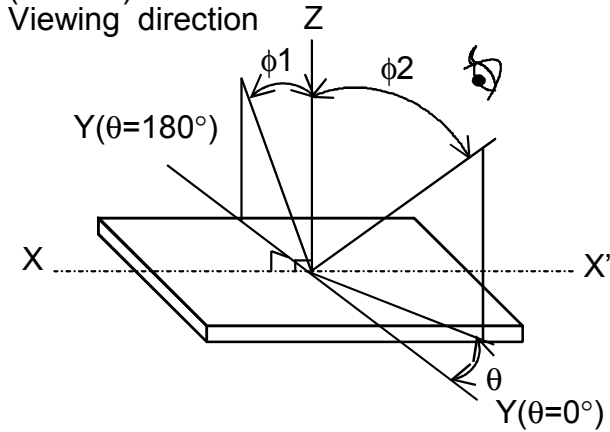

Note 3. Definition of contrast "K"

$$K = \frac{\text{Brightness of selected area (B1)}}{\text{Brightness of non-selected area (B2)}}$$

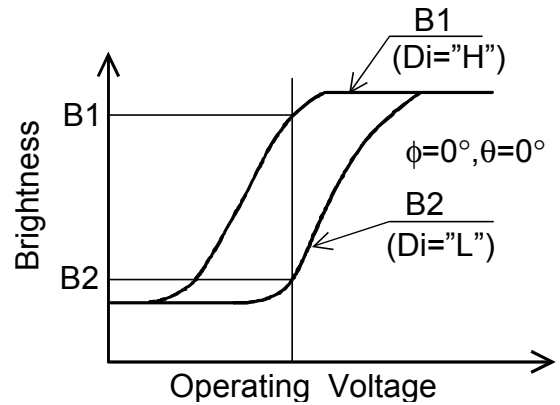

Note 2. Definition of viewing angle  $\phi_1$  and  $\phi_2$

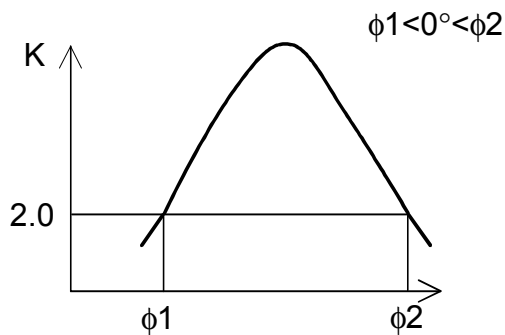

Contrast ratio k vs viewing angle  $\phi$

Note 4. Definition of optical response time

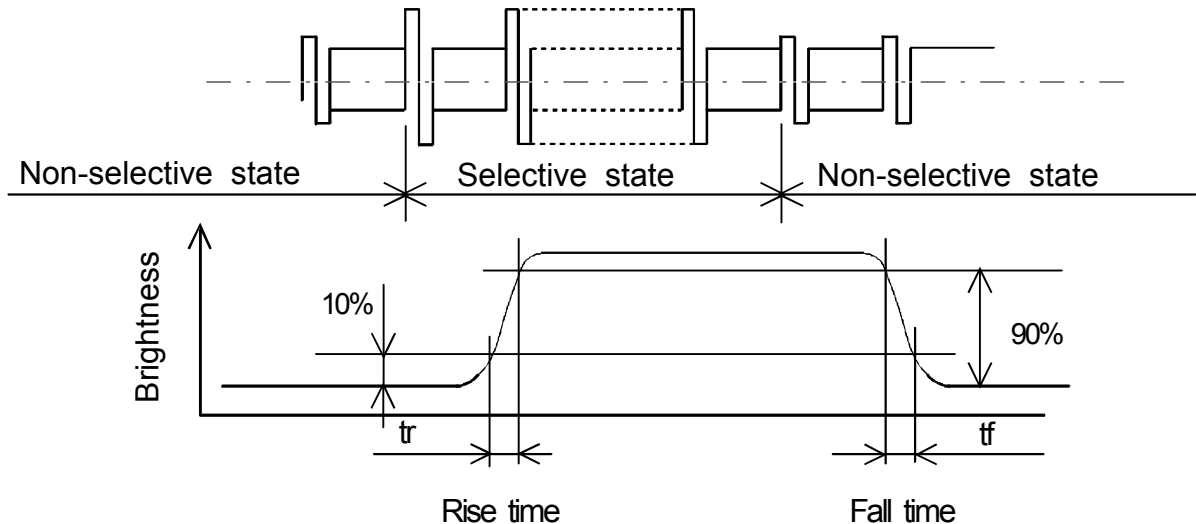

Note 5. Hitachi will not do 100% inspection for minimum value. Minimum value is for reference.

Note 6 Hitachi will do sampling inspection for minimum value.

Note 7 The LCD driving voltage should be adjusted at the voltage where the peak contrast is obtained.

## 6.2 POTICAL CHARACTERISTICS OF BACKLIGHT

ITEM	MIN.	TYP.	MAX.	UNIT	NOTE
Brightness	-	(50)	-	cd/m <sup>2</sup>	IL=1.0mA Note1),2)
Rise time	-	(3)	-	Minute	IL=1.0mA Brightness 80%
Brightness uniformity	-	-	(± 30)	%	Undermentioned Note 1),3)

(Measurement condition : Hitachi standard)

CFL:0h operation, Ta=25°C

Display data should all be "ON"

The LCD driving voltage should be adjusted so as to obtain maximum contrast when display pattern is all "Q".

(Note 1) Measurement after 10 minutes from CFL operating.

Average value of 9 points (Note 3)

(Note 2) Brightness control : 100%.

(Note 3) Measurement of the following 9 places on the display.

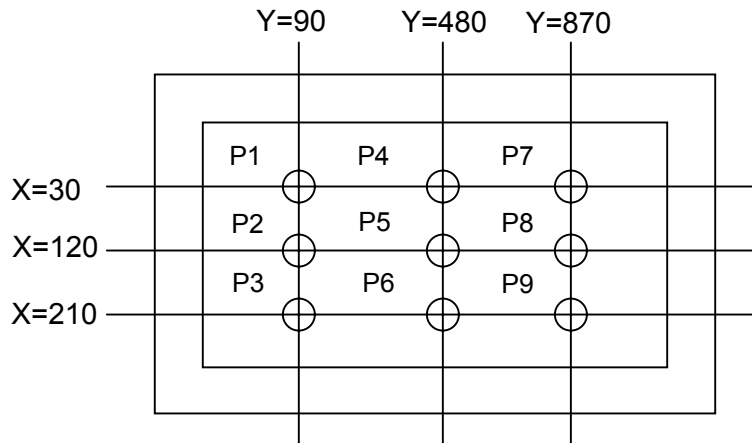

(Note 4) Definition of the brightness tolerance.

$$\left( \frac{\text{Max brightness or Min brightness} - \text{Average brightness}}{\text{Average brightness}} \right) \times 100$$

## 7. BLOCK DIAGRAM

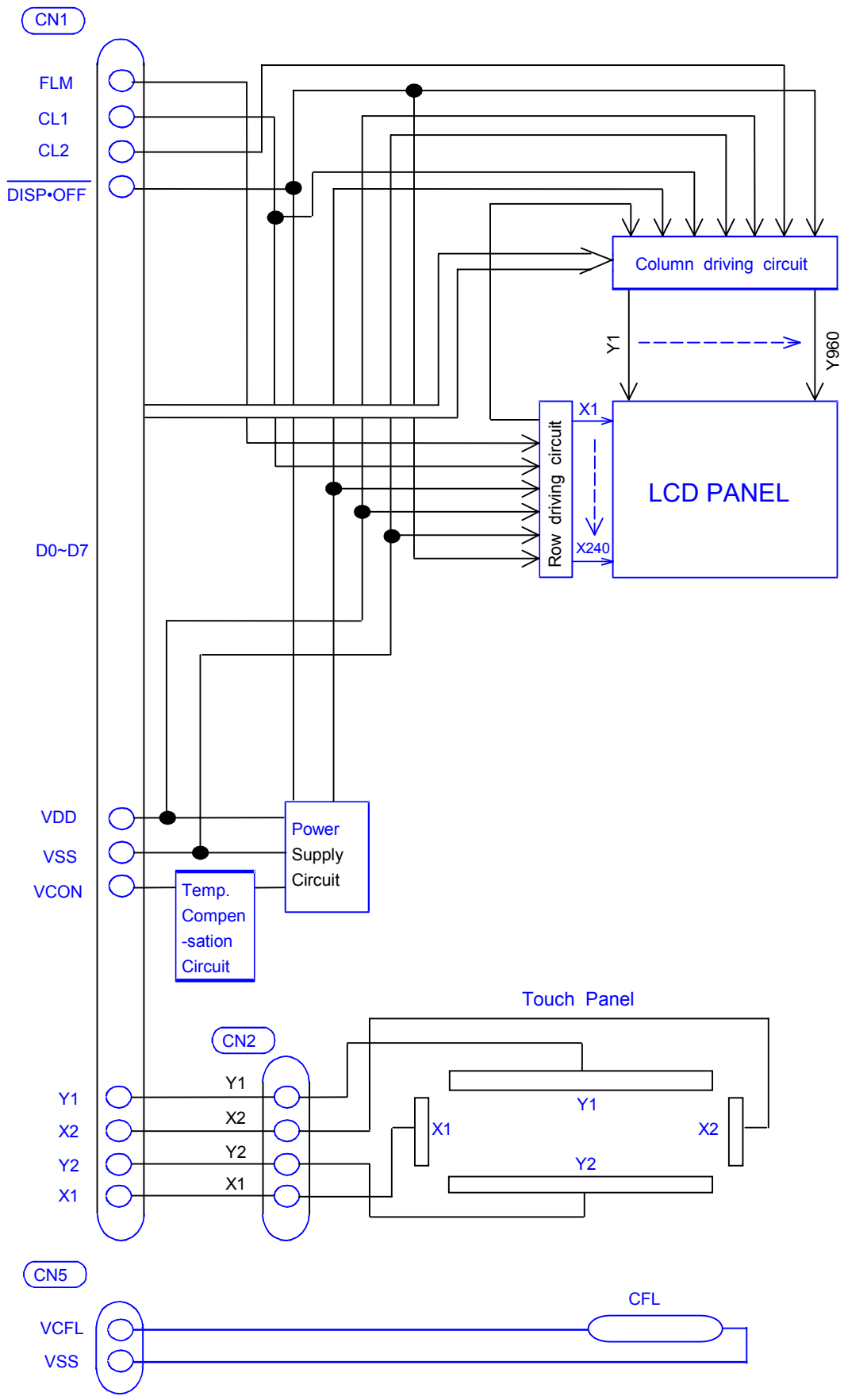

# 8.INTERFACE TIMING CHART

## 8.1 TIMING CHART

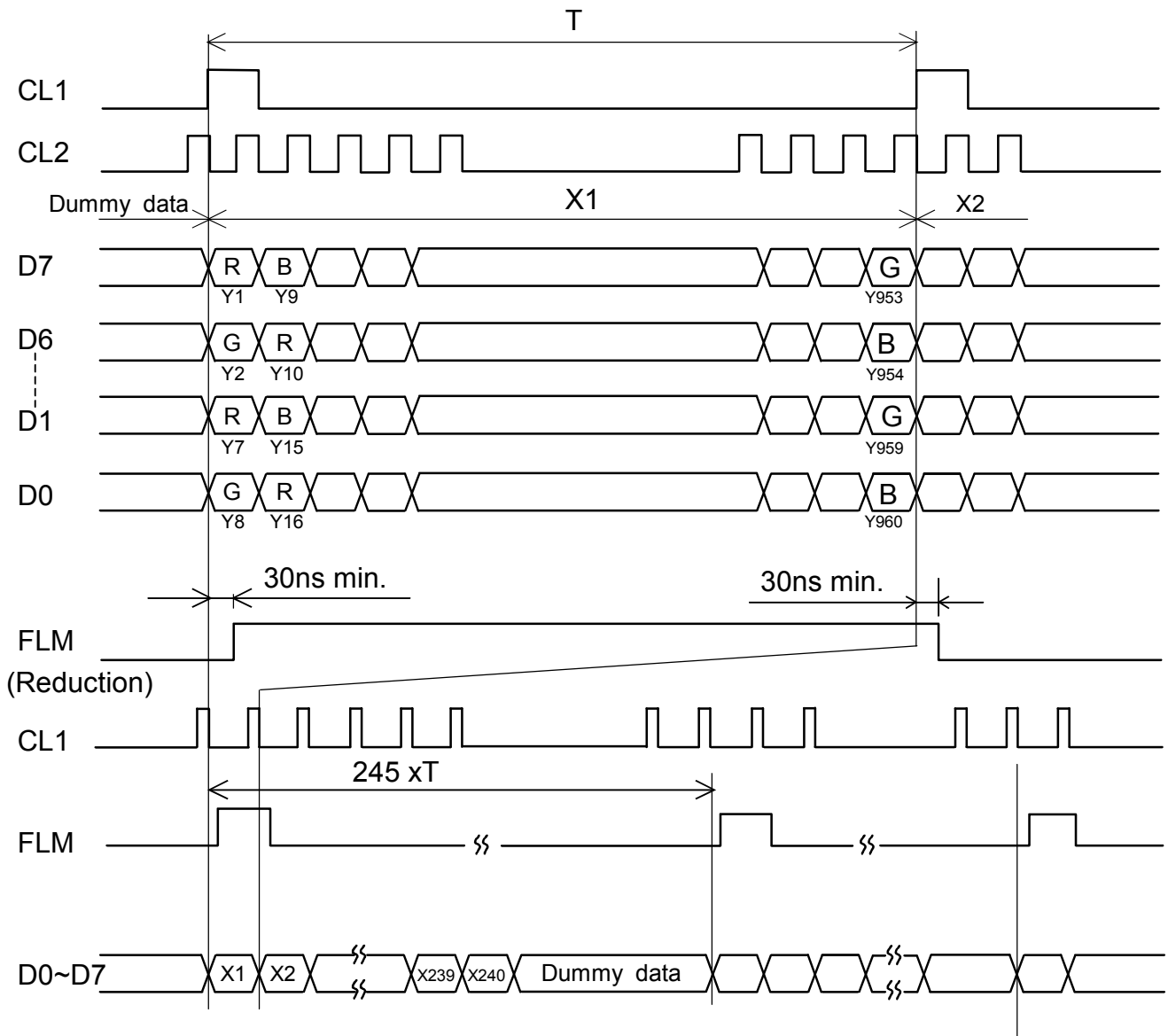

## 8.2 TIMING CHARACTERISTICS

VDD=3.3+/-0.15V, VSS=0V, Vcon=1.0~VDD, Ta=+5°C~+40°C

ITEM	SYMBOL	MIN.	TYP.	MAX.	UMIT
CL1 Pulse width "H"	tWHCL1	100	-	-	ns
Clock cycle time	tCYC	60	-	-	ns
CL2 pulse width	tWCL2	30	-	-	ns
Clock set up time	tSCL1	40	-	-	ns
Clock hold time	tHCL1	80	-	-	ns
Clock rise fall time	tr,tf	-	-	30	ns
Data set up time	tDSU	20	-	-	ns
Data hold time	tDH	20	-	-	ns
"FLM" set up time	tFS	100	-	-	ns
"FLM" hold time	tFH	50	-	-	ns

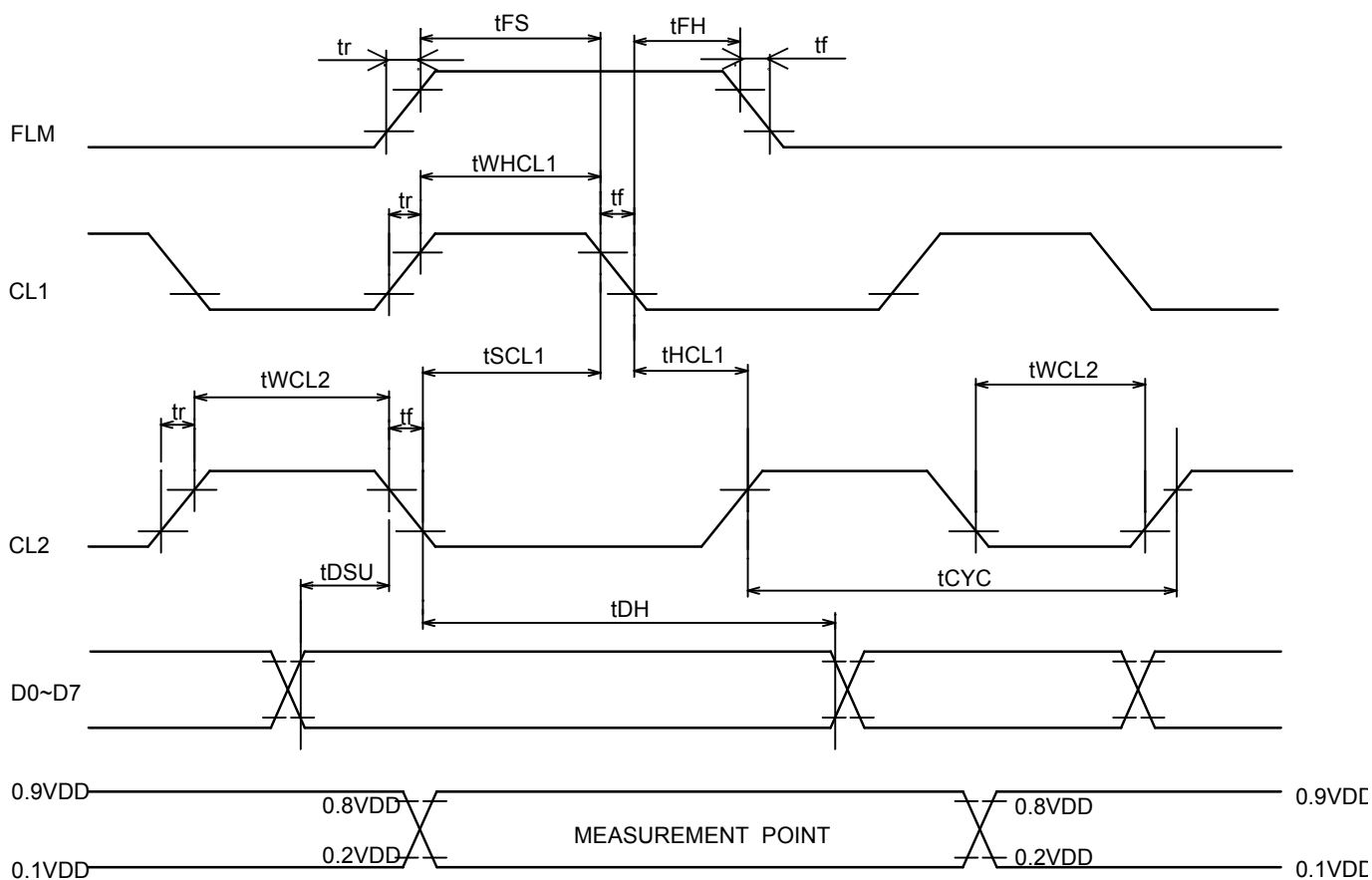

### 8.3 POWER ON/OFF SEQUENCE

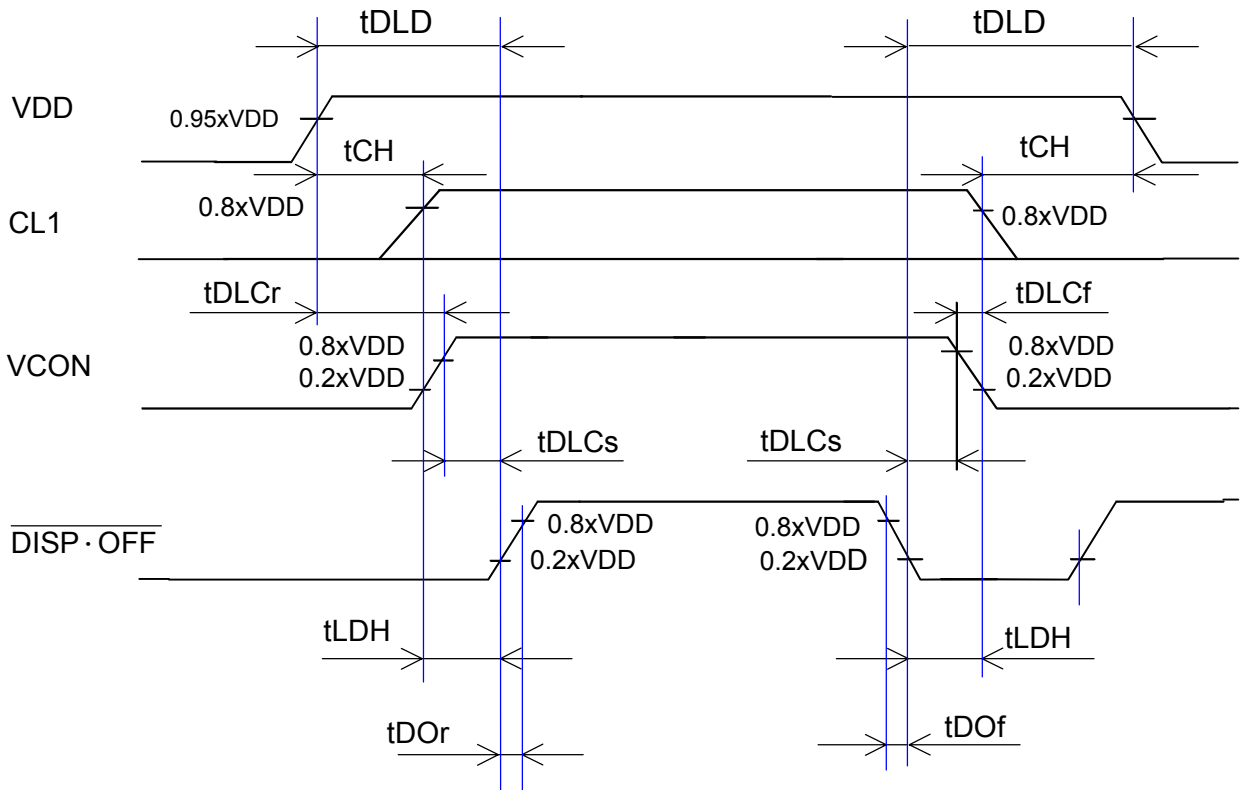

SYMBOL	MIN	MAX	UNIT	COMMENT
tDLD	200	-	ms	(Note 1)
tCH	0	-	ms	
tLDH	0	-	ms	
tDOr	-	100	ns	(Note 2)
tDOF	-	100	ns	
tDLCr	0	-	ms	
tDLCf	0	-	ms	
tDLCs	20	-	ms	

(Note 1) Please keep the specified sequence because wrong sequence may cause permanent damage to the LCD panel.

(Note 2) Hitachi recommends you to use  $\overline{\text{DISP}}\bullet\text{OFF}$  function.

Display quality may deteriorate if you don't use  $\overline{\text{DISP}}\bullet\text{OFF}$  function.

## 8.4 POWER SUPPLY FOR LCM

(Example)

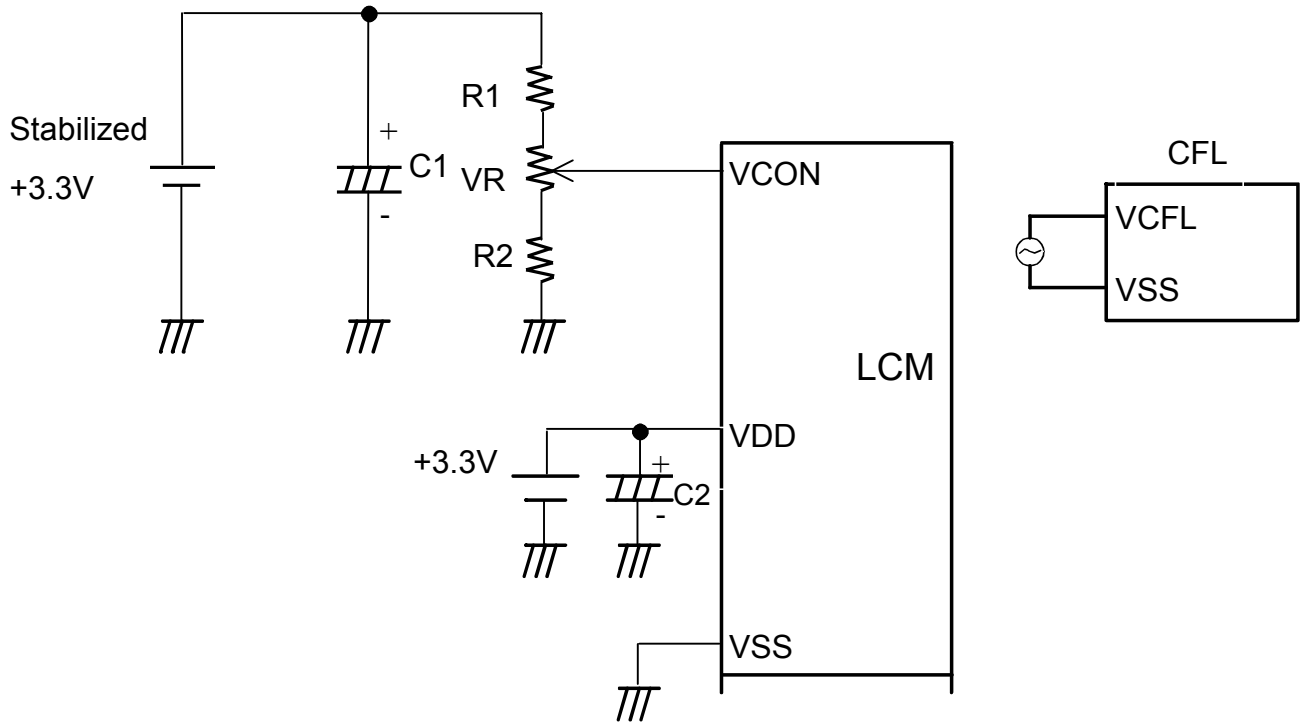

Note 1.  $R1+VR+R2 \leq 10K\Omega$

8.5 INPUT DATA ALLOCATION TABLE

Data Signal	D 7	D 6	D 5	D 4	D 3	D 2	D 1	D 0	D 7	D 6	D 5	D 4	-----	D 4	D 3	D 2	D 1	D 0
	Y												9 5 6	9 5 7	9 5 8	9 5 9	9 5 6	
X	1	2	3	4	5	6	7	8	9	10	11	12						
1	R	G	B	R	G	B	R	G	B	R	G	B	-----	G	B	R	G	B
2	R	G	B	R	G	B	R	G	B	R	G	B	-----	G	B	R	G	B
3	R	G	B	R	G	B	R	G	B	R	G	B	-----	G	B	R	G	B
4	R	G	B	R	G	B	R	G	B	R	G	B	-----	G	B	R	G	B
5	R	G	B	R	G	B	R	G	B	R	G	B	-----	G	B	R	G	B
138	R	G	B	R	G	B	R	G	B	R	G	B	-----	G	B	R	G	B
139	R	G	B	R	G	B	R	G	B	R	G	B	-----	G	B	R	G	B
140	R	G	B	R	G	B	R	G	B	R	G	B	-----	G	B	R	G	B
141	R	G	B	R	G	B	R	G	B	R	G	B	-----	G	B	R	G	B
142	R	G	B	R	G	B	R	G	B	R	G	B	-----	G	B	R	G	B
143	R	G	B	R	G	B	R	G	B	R	G	B	-----	G	B	R	G	B
144	R	G	B	R	G	B	R	G	B	R	G	B	-----	G	B	R	G	B
145	R	G	B	R	G	B	R	G	B	R	G	B	-----	G	B	R	G	B
238	R	G	B	R	G	B	R	G	B	R	G	B	-----	G	B	R	G	B
239	R	G	B	R	G	B	R	G	B	R	G	B	-----	G	B	R	G	B
240	R	G	B	R	G	B	R	G	B	R	G	B	-----	G	B	R	G	B

R : RED  
 G : GREEN  
 B : BLUE



## 8.6 INTERNAL PIN CONNECTION

CN1 JST : 26FLZ – RSM1 - TB (Suitable FPC :  $t0.3 \pm 0.03\text{mm}$  ,  $0.5 \pm 0.03\text{mm}$  pitch)

PIN No.	SIGNAL	LEVEL	FUNCTION
1	N.C	-	-
2	N.C	-	-
3	Y1	-	Analog Signal Touch Panel
4	X1	-	Analog Signal Touch Panel
5	Y2	-	Analog Signal Touch Panel
6	X2	-	Analog Signal Touch Panel
7	VSS	-	GND
8	VCON	-	Contrast Adjustment Voltage
9	VDD	-	Power Supply for Logic
10	$\overline{\text{DISP}} \bullet \text{OFF}$	H / L	H : ON / L : OFF
11	D7	H / L	Display Data
12	D6		
13	D5		
14	D4		
15	VSS	-	GND
16	D3	H / L	Display Data
17	D2		
18	D1		
19	D0		
20	VSS	-	GND
21	VDD	-	Power Supply for Logic
22	CL2	H→L	Data shift
23	VSS	-	GND
24	CL1	H→L	Data Latch
25	VSS	-	GND
26	FLM	H	First Line Marker

CN5 JST Housing : BHSR-02VS-1 (Suitable Connector : JST SM02B-BHSS-1)  
Contact pin : SBHS-002T-P0.5

PIN No.	SIGNAL	LEVEL	FUNCTION
1	VCFL	-	Power Supply for CFL
2	VSS	-	GND for CFL

9. DIMENSIONAL OUTLINE  
9.1 DIMENSIONAL OUTLINE OF LCM

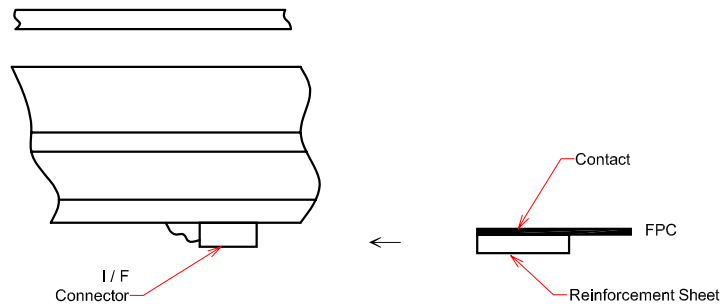
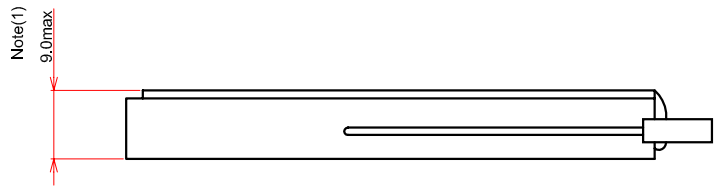
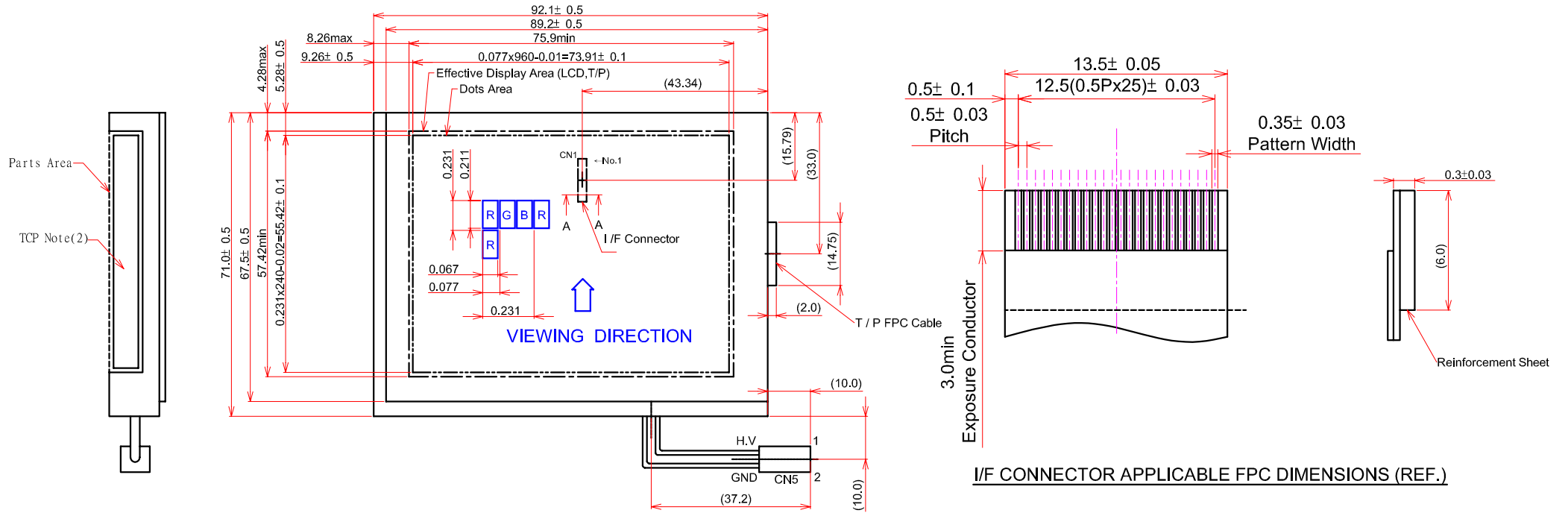

I/F CONNECTOR APPLICABLE FPC DIMENSIONS (REF.)

Note(1) Measurement should be done under pressure of  $9.8 \times 10^4$  Pa at the measurement point.

Note(2) TCP are not covered.  
Please do not touch the TCP by design and hand.

## 10. APPEARANCE STANDARD

### 10.1 APPEARANCE INSPECTION CONDITION

Visual inspection should be done under the following condition.

- (1) The inspection should be done in a dark room.
- (2) The CFL should be lighted with the prescribed inverter.
- (3) The distance between eyes of an inspector and the LCD module is 25cm.
- (4) The viewing zone is shown the figure.

Viewing angle  $\leq 25^\circ$  .

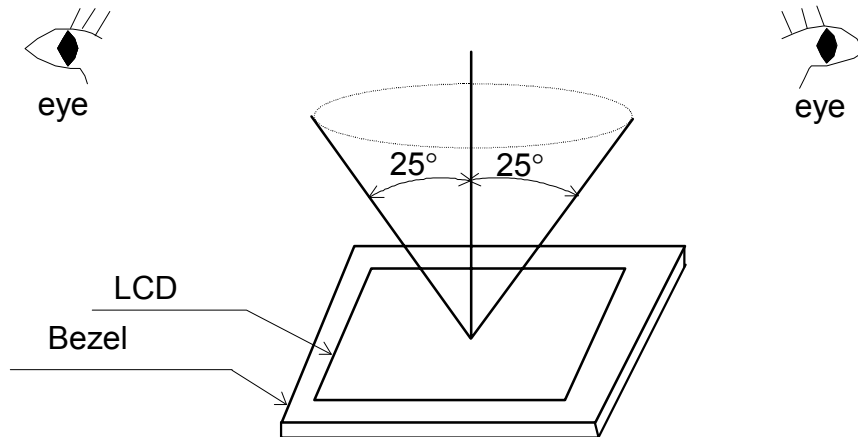

### 10.2 DEFINITION OF ZONE

A zone : The effective display area specified at page 9-1/1 of this document.

B zone : Area between the effective window of bezel line and the effective display area (A zone) line specified at page 9-1/1 of this document.

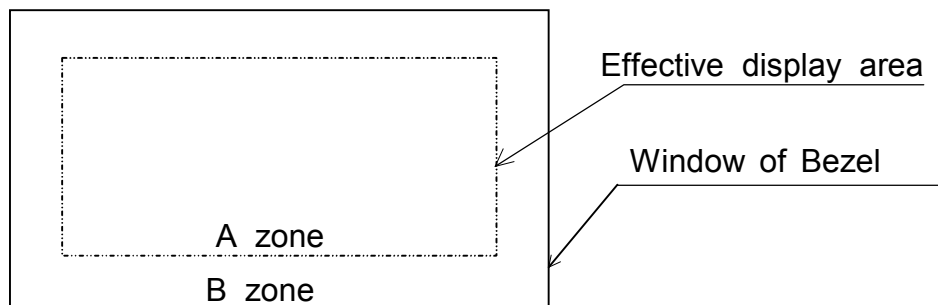

### 10.3 APPEARANCE SPECIFICATION

#### (1)LCD APPEARANCE

\* If the problem related to this section occurs about this item , the responsible persons of both party (Customer and Hitachi) will discuss the matter in detail.

No.	ITEM	CRITERIA			APPLIED ZONE
L C D	Scratches	Distinguished one is not acceptable (To be judged by HITACHI standard)			A
	Dent	Same as above			A
	Wrinkles in Polarizer	Same as above			A
	Bubbles	Average diameter D(mm)	Maximum Acceptable number		A
		$D \leq 0.2$	ignored		
		$0.2 < D \leq 0.3$	12		
		$0.3 < D \leq 0.5$	3		
		$0.5 < D$	none		
	Stains, Foreign Materials Dark spot	Filamentous (Line shape)			A
		Length L(mm)	Width W(mm)	Maximum accept- -able number	
		$L \leq 2.0$	$W \leq 0.03$	ignored	
		$L \leq 3.0$	$0.03 < W \leq 0.05$	6	
		$L \leq 2.5$	$0.05 < W \leq 0.1$	1	
		Round(Dot shape)			A
		Average diameter D(mm)	Maximum acceptable number	Minimum Space	
		$D < 0.2$	ignored	-	
		$0.2 \leq D < 0.3$	10	10 mm	
		$0.3 \leq D < 0.4$	5	30 mm	
	$0.4 \leq D$	none	-		
	The total number	Filamentous+Round=10			
	Those wiped out easily are acceptable				
Color tone	To be judged by HITACHI standard			A	
Color uniformity	Same as above			A	

No.	ITEM	CRITERIA				APPLIED ZONE			
L	Contrast irregularity (Spot)	Average diameter D(mm)	Contrast	Maximum acceptable number	Minimum space	A			
		$D \leq 0.25$					To be Judged by HITACHI standard	ignored	-
		$0.25 < D \leq 0.35$						10	20mm
		$0.35 < D \leq 0.5$						4	20mm
		$0.5 < D \leq 0.7$						3	50mm
$0.7 < D$	None	-							
C D	Contrast irregularity (Line) (A pair of scratches)	Width W(mm)	Length L(mm)	Maximum Acceptable number	Minimum space	A			
		$W \leq 0.25$	$L \leq 1.2$	2	20mm				
		$W \leq 0.2$	$L \leq 1.5$	3	20mm				
		$W \leq 0.15$	$L \leq 2.0$	3	20mm				
		$W \leq 0.1$	$L \leq 3.0$	4	20mm				
		The whole number		6					
Rubbing Scratch		To be judged by HITACHI standard			-				

(2) CFL BACKLIGHT APPEARANCE

No.	ITEM	CRITERIA			APPLIED ZONE
C F L	Dark spots White spots Foreign materials (Spot)	Average diameter D(mm)	Maximum Acceptable number		A
		$D \leq 0.4$	ignored		
		$0.4 < D$	none		
B A C K L I G H T	Foreign materials (Line)	Width W(mm)	Length L(mm)	Maximum Acceptable number	A
		$W \leq 0.2$	$L \leq 2.5$	1	
			$2.5 < L$	None	
		$0.2 < W$	-	none	
S C R A T C H E S	Scratches	Width W(mm)	Length L(mm)	Maximum acceptable number	A
		$W \leq 0.1$	-	ignored	
		$0.1 < W \leq 0.2$	$L \leq 11.0$	1	
			$11.0 < L$	None	
		$0.2 < W$	-	none	

(3) TOUCH PANEL APPEARANCE

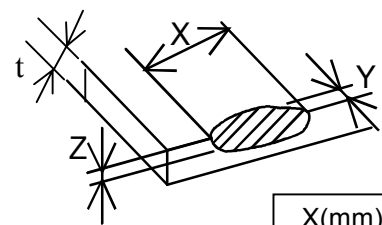
No.	ITEM	CRITERIA		APPLIED ZONE											
TOUCH PANEL	Foreign material (Black or White spots)	Average diameter D (mm)	Criteria	A											
		$D \leq 0.2$	Ignored												
		$0.2 < D \leq 0.4$	1 (Note 3)												
		$0.4 < D$	none												
	Foreign material (Line)	Length L (mm), Width W (mm)	Criteria	A											
		$L \leq 3.0$ and $W \leq 0.05$	Ignored												
		$L \leq 3.0$ and $0.05 < W \leq 0.1$	1 (Note 3)												
		$L > 3.0$ and $0.1 < W$	none												
	Uncleanliness	No conspicuous dirt		A											
	Crack in plastic plate	No cracks are allowed		A											
Scratch	Length L (mm) Width W (mm)	criteria	A												
	$L \leq 5.0$ and $W \leq 0.03$	ignored													
	$5 < L \leq 15$ and $W \leq 0.05$ or $L \leq 15$ and $0.03 < W \leq 0.05$	1													
	$L > 15$ and $0.05 < W$	none													
Chip and Crack	General chip X : Width direction to ridge line Y : Length direction to ridge line Z : Thickness direction to ridge line t : Plastic thickness 		-												
		<table border="1"> <thead> <tr> <th>X(mm)</th> <th>Y(mm)</th> <th>Z(mm)</th> </tr> </thead> <tbody> <tr> <td><math>\leq 3.0</math></td> <td><math>\leq 3.0</math></td> <td><math>\leq t</math></td> </tr> <tr> <td><math>\leq 5.0</math></td> <td><math>\leq 1.0</math></td> <td><math>\leq t</math></td> </tr> <tr> <td><math>\leq 5.0</math></td> <td><math>\leq 3.0</math></td> <td><math>\leq 2/3 t</math></td> </tr> </tbody> </table>	X(mm)	Y(mm)	Z(mm)	$\leq 3.0$	$\leq 3.0$	$\leq t$	$\leq 5.0$	$\leq 1.0$	$\leq t$	$\leq 5.0$	$\leq 3.0$	$\leq 2/3 t$	
X(mm)	Y(mm)	Z(mm)													
$\leq 3.0$	$\leq 3.0$	$\leq t$													
$\leq 5.0$	$\leq 1.0$	$\leq t$													
$\leq 5.0$	$\leq 3.0$	$\leq 2/3 t$													

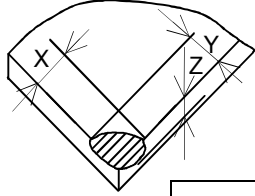
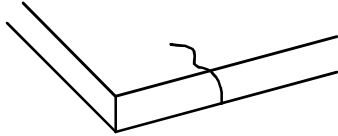
NO.	ITEM	CRITERIA	APPLIED ZONE									
T O U C H  P A N E L	Chip and Crack	Corner chip t: Plastic thickness  <table border="1" data-bbox="850 521 1157 667"> <thead> <tr> <th>X(mm)</th> <th>Y(mm)</th> <th>Z</th> </tr> </thead> <tbody> <tr> <td>≤ 3.0</td> <td>≤ 3.0</td> <td>≤ t</td> </tr> <tr> <td>≤ 5.0</td> <td>≤ 3.0</td> <td>≤ 2/3t</td> </tr> </tbody> </table>	X(mm)	Y(mm)	Z	≤ 3.0	≤ 3.0	≤ t	≤ 5.0	≤ 3.0	≤ 2/3t	-
	X(mm)	Y(mm)	Z									
≤ 3.0	≤ 3.0	≤ t										
≤ 5.0	≤ 3.0	≤ 2/3t										
	Bad crack (possibly expanding)  ALL shall be rejected  											

Note (1) Definition of average diameter (D)

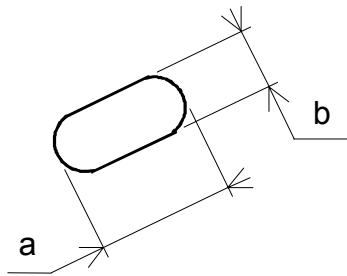

$$D = \frac{a+b}{2}$$

Note (2) Definition of length (L) and width (W)

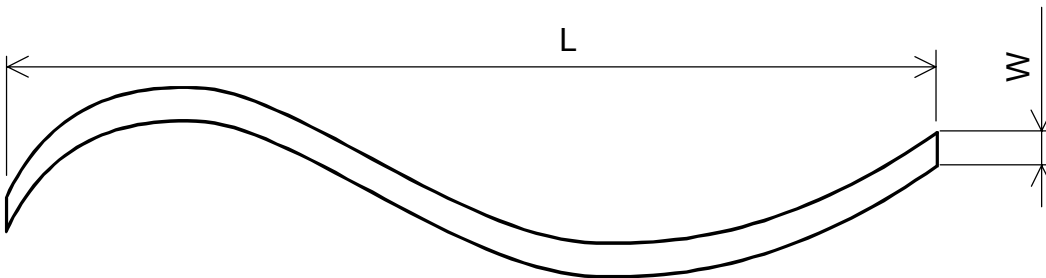

Note (3) Within  $\phi 4.0$ : foreign matter at center of the circle.

## 11. PRECAUTION IN DESIGN

### 11.1 MOUNTING PRECAUTION

(1) When assembling the touch panel and you case, please refer to the figure below.

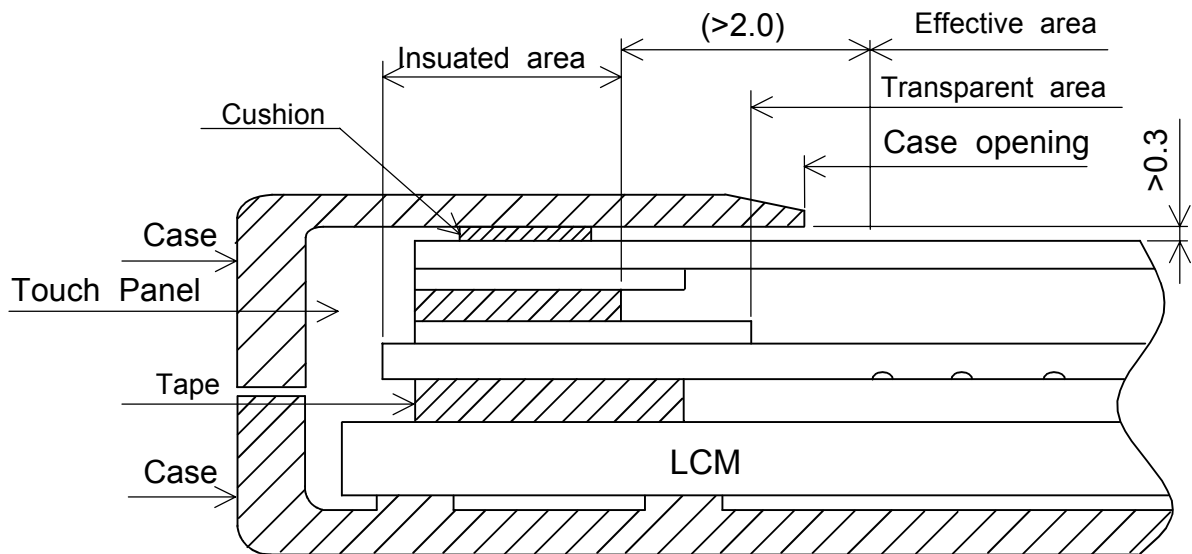

- (2) The clearance between the touch panel and case shall be designed so that the case edge never presses the input screen when it is deformed by heat or other causes.
- (3) The case shall be designed not to touch the tail portion (FPC for touch panel).
- (4) The boundary space between the effective area and the insulated area is unstable. Touching this area may effect the operation of the touch panel. The case must be designed so that it does not touch the boundary space.

### 11.2 PRECAUTIONS AGAINST ELECTROSTATIC DISCHARGE

As this module contains C-MOS LSIs, it is not strong against electrostatic discharge. Make certain that the operator's body is connected to the ground through a wrist band etc.

And don't touch I/F pins directly.

### 11.3 POWER ON SEQUENCE

Input signals should not be applied to LCD module before power supply voltage is applied and reaches to specified voltage.

If the above sequence is not kept, C-MOS LSIs of LCD module may be damaged due to latch up phenomenon.

### 11.4 HANDLING PRECAUTIONS

- (1) Since the polarizer on the top, and the aluminum plate on the bottom tend to be easily damaged, they should be with full care so as not to get them touched, pushed or rubbed by a piece of glass, tweezers and anything else which are harder than a pencil lead 3H.



- (2) As the adhesives used for adhering upper/lower polarizers and aluminum plate are made of organic substances which will be deteriorated by a chemical reaction with such chemicals as acetone, toluene, ethanol and isopropylalcohol. The following are recommended for use : Normal hexane  
Please contact us when it is necessary for you to use chemicals other than The above.
- (3) Lightly wipe to clean the dirty surface with absorbent cotton or other soft material like chamois, soaked in the recommended chemicals without scrubbing it hardly.  
Always wipe the surface horizontally or vertically. Never give a wipe in a circle. To prevent the display surface from damage and keep the appearance in good state, it is sufficient, in general, to wipe it with absorbent cotton.
- (4) Immediately wipe off saliva or water drop attached on the display area because it may cause deformation or faded color.
- (5) Foggy dew deposited on the surface may cause a damage, stain or dirt to the polarizer.  
When you need to take out the LCD module from some place at low temperature for test, etc.  
It is required to be warmed them up to temperature higher than room temperature before taking them out.
- (6) Touching the display area or I/F pins with bare hands or contaminating them are prohibited, because the stain on the display area and poor insulation between terminals are often caused by being touched with bare hands.  
(Some cosmetics are detrimental to polarizers.)
- (7) In general, the glass is fragile so that, especially on its periphery, tends to be cracked or chipped in handling. Please not give the LCD module sharp shocks by falling etc.
- (8) Maximum pressure to the surface must be less than  $1.96 \times 10^4$  Pa.  
And if the pressure area is less than  $1\text{cm}^2$ , maximum pressure must be less than 1.96N.
- (9) Since the metal width is narrow on these locations (see page 9-1/1), please careful with handling.
- (10) Top sheets shall be cleaned gently using a soft cloth such as those used for glasses.  
Hard wiping accumulated dust will leave scars on the surface even using a cloth.

#### 11.5 OPERATION PRECAUTION

- (1) Using a LCM module beyond its maximum ratings may result in its permanent destruction.  
LCM module's should usually be used under recommended operating conditions shown in chapter 5. Exceeding any of these conditions may adversely affect its reliability.

KAOHSIUNG HITACHI ELECTRONICS CO.,LTD.	DATE	Aug.03.'01	Sh. No.	7B64LTD2122- SX09Q002-BZA-1	PAGE	11-2/3
-------------------------------------------	------	------------	------------	-----------------------------	------	--------

- (2) Response time will be extremely delayed at lower temperature than the specified operating temperature range and on the other hand LCD's shows dark blue at higher temperature.  
How ever those phenomena do not mean defects of the LCD module. Those phenomena will disappear in the specified operating temperature range.
- (3) If the display area is pushed hard during operation, some display patterns will be abnormally displayed.
- (4) A slight dew depositing on terminals may cause electrochemical reaction which leads to terminal open circuit. Please operate the LCD module under the relative condition of 40°C 85%RH.
- (5) Resistance range : Your controller shall be set up to allow the resistance range of touch panel specified in our CAS.
- (6) Pointed position of touch panel may shift owing to a change in resistance of touch panel depending on the operation condition . To compensate this shift, the set shall be given a calibration function.
- (7) Input shall be made with a stylus pen (polyacetal , R0.8). Chances are very high that use of a metal piece including a ball point pen or sharp edge will impair accuracy.
- (8) The touch panel is an auxiliary input device. The system shall be designed to have other input device.

#### 11.6 STORAGE

In case of storing LCD module for a long period of time (for instance, for years) for The purpose of replacement use, the following precautions necessary.

- (1) Store the LCD modules in a dark place; do not expose them to sunlight or ultraviolet rays.
- (2) Keep the temperature between 10°C and 35°C at normal humidity.
- (3) Store the LCD modules in the container which is used for shipping from us.
- (4) No articles shall be left on the surface over an extended period of time.

#### 11.7 SAFETY

The LCD modules include Cold Cathode Fluorescent Lamp(CFL). CFL contains a small amount of mercury. Please follow local ordinances or regulations for disposal.

Wear finger cots or gloves whenever handling or assembling a touch panel its glass edges are sharp.

KAOHSIUNG HITACHI ELECTRONICS CO.,LTD.	DATE	Aug.03.'01	Sh. No.	7B64LTD2122- SX09Q002-BZA-1	PAGE	11-3/3
-------------------------------------------	------	------------	------------	-----------------------------	------	--------



12.2 REVISION

REV No.	ITEM	LOT No.	PRODUCTION CONTROL No.
A	Segment LCD Driver : BD66134U		00001~
B	Segment LCD Driver : WFP-7102		00001~

### 13. PRECAUTION FOR USE

(1) A limit sample should be provided by the both parties on an occasion when the both parties agree to its necessity.

Judgement by a limit sample shall take effect after the limit sample has been established and confirmed by the both parties.

(2) On the following occasions, the handling of the problem should be decided through discussion and agreement between responsible persons of the both parties.

(1) When a question is arisen in the specifications.

(2) When a new problem is arisen which is not specified in this specifications.

(3) When an inspection specifications change or operating condition change by customer is reported to HITACHI, and some problem is arisen in the specification due to the change.

(4) When a new problem is arisen at the customer's operating set for sample evaluation.

(3) Regarding the treatment for maintenance and repairing, both parties will discuss it in six month later after latest delivery of this product.

The precaution that should be observed when handling LCM have been explained above.

If any points are unclear or if you have any requests , please contact with HITACHI.