

CRYSTAL CONTROLLED OSCILLATORS

5.0V HCMOS VCTCXO 14 Pin DIP Crystal Oscillator

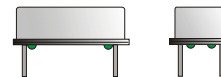

HTVx-Series
HTVxA-Series

ABSOLUTE MAXIMUM RATINGS

TABLE 1.0

PARAMETER	UNITS	MINIMUM	NOMINAL	MAXIMUM	UNITS	NOTE
Storage Temperature		-40	-	85	°C	
Supply Voltage	(Vcc)	-0.5	-	7	Vdc	
Control Voltage	(Vc)	-0.5	-	7	Vdc	

MODEL SPECIFICATIONS

MODEL HTV1 / HTV1A

TABLE 2.0

HTV1 - Frequency Range	(Fo)	.110	-	12.7999	MHz	
HTV1A - Frequency Range	(Fo)	12.8	-	60	MHz	
Frequency Stability vs. Change in Temperature		-0.5	-	0.5	ppm	
Operating Temperature Range		20	-	40	°C	
Total Frequency Tolerance		-8.0	-	8.0	ppm	1

MODEL HTV2 / HTV2A

HTV2 - Frequency Range	(Fo)	.110	-	12.7999	MHz	
HTV2A - Frequency Range	(Fo)	12.8	-	60	MHz	
Frequency Stability vs. Change in Temperature		-1.0	-	1.0	ppm	
Operating Temperature Range		0	-	50	°C	
Total Frequency Tolerance		-8.5	-	8.5	ppm	1

MODEL HTV3 / HTV3A

HTV3 - Frequency Range	(Fo)	.110	-	12.7999	MHz	
HTV3A - Frequency Range	(Fo)	12.8	-	60	MHz	
Frequency Stability vs. Change in Temperature		-2.5	-	2.5	ppm	
Operating Temperature Range		0	-	70	°C	
Total Frequency Tolerance		-10.0	-	10.0	ppm	1

MODEL HTV4 / HTV4A

HTV4 - Frequency Range	(Fo)	.110	-	12.7999	MHz	
HTV4A - Frequency Range	(Fo)	12.8	-	60	MHz	
Frequency Stability vs. Change in Temperature		-5.0	-	5.0	ppm	
Operating Temperature Range		-30	-	70	°C	
Total Frequency Tolerance		-12.5	-	12.5	ppm	1

OPERATING SPECIFICATIONS

TABLE 3.0

PARAMETER		MINIMUM	NOMINAL	MAXIMUM	UNITS	NOTE
Frequency Calibration @ 25°C		-2.5	-	2.5	ppm	2
Frequency Aging First Year		-2.0	-	2.0	ppm	
Frequency Aging Ten Years (Including first year)		-5.0	-	5.0	ppm	
Supply Voltage	(Vcc)	4.75	5.0	5.25	Vdc	
Supply Current	(Icc)	-	15	35	mA	
Jitter (BW=10Hz to 20MHz)		-	-	5	ps rms	
Jitter (BW=12kHz to 20MHz)		-	-	1	ps rms	
Typical Phase Noise						
SSB Phase Noise at 10Hz offset		-	-70	-	dBc/Hz	
SSB Phase Noise at 100Hz offset		-	-100	-	dBc/Hz	
SSB Phase Noise at 1KHz offset		-	-125	-	dBc/Hz	
SSB Phase Noise at 10KHz offset		-	-135	-	dBc/Hz	
SSB Phase Noise at 100KHz offset		-	-145	-	dBc/Hz	

INPUT CHARACTERISTICS

TABLE 4.0

PARAMETER		MINIMUM	NOMINAL	MAXIMUM	UNITS	NOTE
Control Voltage	(Vc)	0.5	2.5	4.5	Vdc	
Frequency Adjust Range (0.5 to 4.5V)		±8	-	±35	ppm	3
Frequency Adjust Linearity		-15	-	15	%	
Input Impedance		10k	-	-	Ohm	

DESCRIPTION

Description:
The Connor Winfield HTV-Series and the HTVxA-Series are 5.0V HCMOS, hermetically sealed, Voltage Controlled Temperature Compensated Crystal Oscillator (VCTCXO). The HTV-Series and the HTVxA-Series are designed for application requiring very tight frequency stability and low jitter.

FEATURES

5.0V OPERATION

LOW JITTER <1ps RMS

FREQUENCY STABILITY:HTV1
HTV1 / HTV1A: ±0.5ppm: 20 to 40°C
HTV2 / HTV2A: ±1.0ppm: 0 to 50°C
HTV3 / HTV3A: ±2.5ppm: 0 to 70°C
HTV4 / HTV4A: ±5.0ppm: -30 to 70°C

FREQUENCY ADJUST

HERMETICALLY SEALED DIP PACKAGE

ORDERING INFORMATION

HTV2A - 27.0MHz

TCXO
SERIES

CENTER
FREQUENCY

Specifications subject to change without notice.

CRYSTAL CONTROLLED OSCILLATORS

HCMOS OUTPUT CHARACTERISTICS

TABLE 5.0

PARAMETER		MINIMUM	NOMINAL	MAXIMUM	UNITS	NOTE
LOAD		-	-	15	pF	
Voltage	(High)	(Voh)	4.2	4.5	-	Vdc
	(Low)	(Vol)	-	-	0.4	Vdc
HTVx - Series Current	(High)	(Ioh)	-4	-	-	mA
	(Low)	(Ioh)	-	-	4	mA
HTVxA-Series - Current	(High)	(Ioh)	-8	-	-	mA
	(Low)	(Ioh)	-	-	8	mA
Duty Cycle at 50% of Vcc		45	50	55	%	
Rise / Fall Time 10% to 90%			3	5	nS	

PACKAGE CHARACTERISTICS

TABLE 6.0

Package	Hermetically sealed, metal package.
---------	-------------------------------------

Note:

- 1) Inclusive of calibration, frequency vs. temperature stability, supply voltage change, load change, shock and vibration, 10 years aging.
- 2) Frequency calibration at 25°C, Vc = 2.5V, nominal Vcc, after one minute warm up time.
- 3) Positive Slope.

PACKAGE OUTLINE

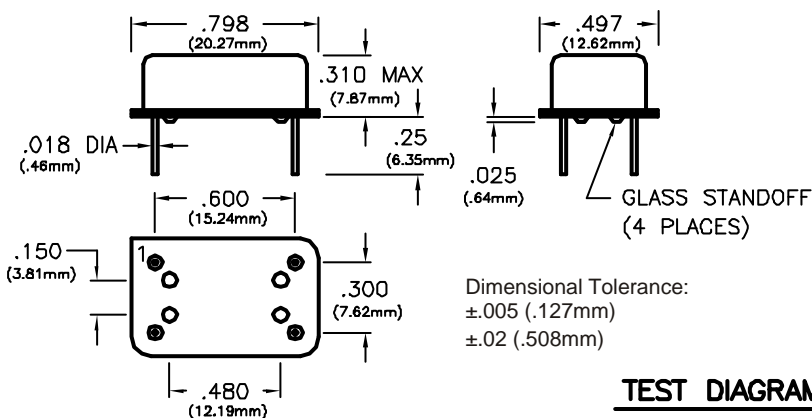
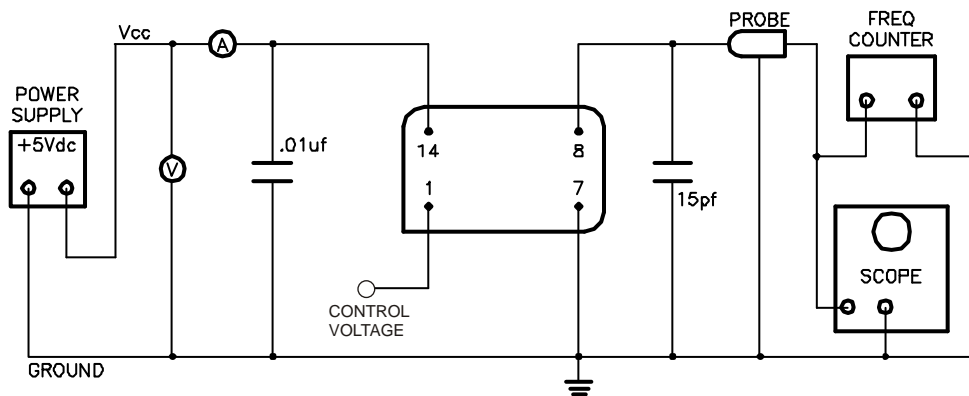

TABLE 7.0

Pin	Connection
1	Control Voltage
7	Ground
8	Output
14	Vcc

TEST DIAGRAM



Specifications subject to change without notice.