

624-408

# HFD3023

## 5 Mbit Direct Coupled Receiver

### FEATURES

- Converts fiber optic input signals to TTL digital outputs
- Typical sensitivity 2  $\mu$ W (-27 dBm)
- Single 5 V supply requirement
- Direct coupled receiver circuit
- Open collector output
- Plastic cap with TO-18 header for easy-to-align press fit into optical connectors
- Microlens optics for efficient fiber coupling
- Designed to operate with Honeywell 850 nm LEDs and integrated transmitters

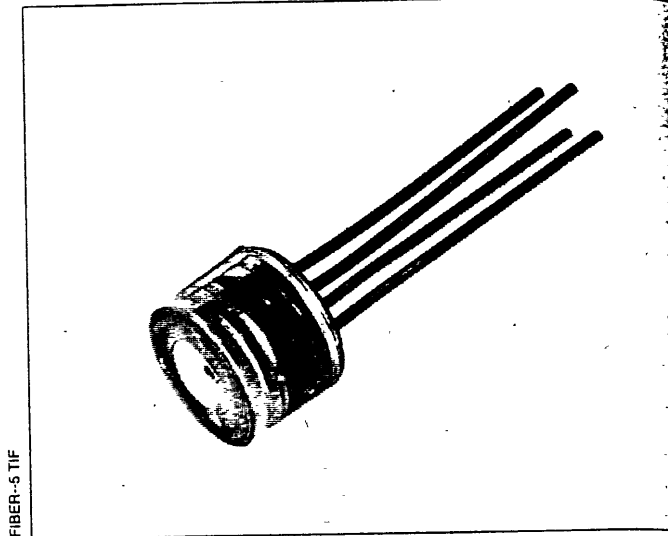

FIBER-5 TIF

### DESCRIPTION

The HFD3023 is a sensitive Direct Coupled (DC) optical receiver designed for use in short distance, 850 nm fiber optic systems. The receiver contains a monolithic IC, consisting of a photodiode, DC amplifier, and open collector Schottky output transistor. The output allows it to be directly interfaced with standard TTL circuits. The HFD3023 receiver is supplied in a Honeywell plastic package, and can be mounted in several types of fiber optic connectors.

### APPLICATION

The HFD3023 fiber optic receiver converts the optical signal in a point to point data communications fiber optic link to a TTL output. Its 0.006 in. photodiode with a 0.024 in. microlens (to enhance the optics) is mechanically centered within the TO-18 package. Honeywell can also mount the receiver in various fiber optic connectors.

Electrical isolation is important in obtaining the maximum performance. A 0.1  $\mu$ F bypass capacitor must be connected between Vcc and ground. This minimizes power supply noise, increasing the signal quality. Shielding can also reduce coupled noise, through use of ground plane PCB, shielding around the device, and shielding around the leads.

The HFD3023 is designed for a wide optical input range. The optical input dynamic range is guaranteed from the maximum sensitivity of 3.0  $\mu$ W to 100  $\mu$ W or greater than 15 dB.

Optical power from the fiber strikes the photodiode and is converted to electrical current. This current couples to

### OUTLINE DIMENSIONS in inches (mm)

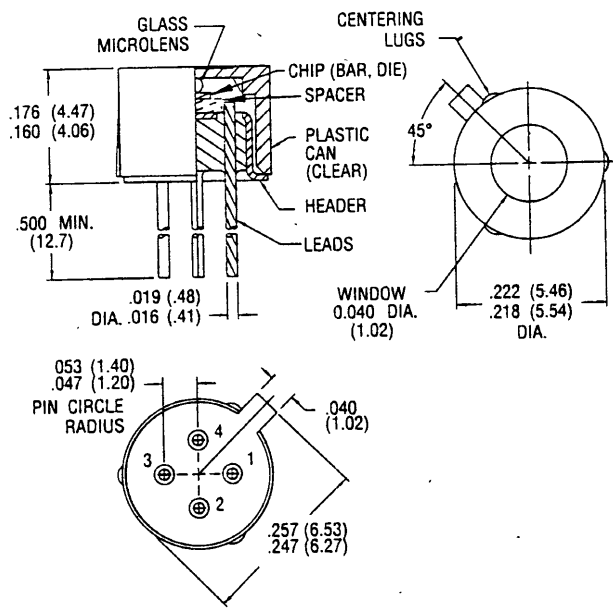

FIBER-11 DIM

### Pinout

1. Vcc
2. Ground
3. Output (TTL)
4. Case (ground)

# HFD3023

## 5 Mbit Direct Coupled Receiver

---

### APPLICATION (continued)

the DC amplifier, which drives an open collector transistor output. The output when connected to a pull up resistor can interface to TTL loads. The electrical signal is the inverse of the input light signal. When light strikes the photodiode, the output is a low logic level. When no light strikes the photodiode, the output is a high logic level.

Pulse Width Distortion (PWD) is an increase in the output pulse width (for high level optical input). The typical performance curves illustrate how PWD varies with optical power, temperature and frequency for the HFD3023. The amount of PWD that a given system can tolerate without an error due to a missing bit of information, is dependent upon system considerations. The output of the HFD3023 will typically connect to the input of some form of a serial interface adaptor IC. The specifications for that IC govern the amount of PWD that can be tolerated in the system.

# HFD3023

## 5 Mbit Direct Coupled Receiver

### ELECTRO-OPTICAL CHARACTERISTICS ( $T_C = 25^\circ\text{C}$ , $V_{CC} = 5\text{ VDC}$ unless otherwise noted)

PARAMETER	SYMBOL	MIN	TYP	MAX	UNITS	TEST CONDITIONS
Minimum Input Sensitivity	$P_{IN}$ (peak)		2.0	3.0	$\mu\text{W}$	$I_P = 850\text{ nm}$ into 100/140 micron fiber, $f = 2.5\text{ MHz}$ , Duty Cycle = 50%, $PWD \leq 10\%$
			-27.0	-25.2	dBm	
High Level Logic Output Voltage	$V_{OH}$	2.4	4.5		V	$P_{IN} \leq 0.1\ \mu\text{W}$ , $R_L = 560\ \Omega$
Low Level Logic Output Voltage	$V_{OL}$		0.25	0.5	V	$P_{IN} \geq 3\ \mu\text{W}$ , $R_L = 560\ \Omega$
Rise Time	$t_r$		6	9	ns	$P_{IN} = 10\ \mu\text{W}$ , $V_O = 0.5 - 2.4\text{ V}$ , $R_L = 560\ \Omega$
Fall Time	$t_f$		6	9	ns	$P_{IN} = 10\ \mu\text{W}$ , $V_O = 2.4 - 0.5\text{ V}$ , $R_L = 560\ \Omega$
Supply Current	$I_{CC}$		13	15	mA	$P_{IN} \geq 3\ \mu\text{W}$
			4.5	6.5		$P_{IN} \leq 0.1\ \mu\text{W}$
Pulse Width Distortion	PWD		5	10	%	$f = 2.5\text{ MHz}$ , Duty Cycle = 50%
			25	35		$P_{IN} = 3\ \mu\text{W peak}$ $P_{IN} = 80\ \mu\text{W peak}$

### ABSOLUTE MAXIMUM RATINGS

( $25^\circ\text{C}$  Free-Air Temperature unless otherwise noted)

Storage temperature	-40 to $+100^\circ\text{C}$
Lead solder temperature	$260^\circ\text{C}$ , 10 s
Supply voltage	+6 V
Junction temperature	$150^\circ\text{C}$
Operating temperature	-40 to $+100^\circ\text{C}$

#### Notes

Stresses greater than those listed under "Absolute Maximum Ratings" may cause permanent damage to the device. This is a stress rating only and functional operation of the device at these or any other conditions above those indicated in the operational section of this specification is not implied. Exposure to absolute maximum rating conditions for extended periods of time may affect reliability.

### RECOMMENDED OPERATING CONDITIONS

Operating temperature	-40 to $+85^\circ\text{C}$
Supply voltage	+4.5 to +5.5 VDC
Optical input power	3 to $100\ \mu\text{W}$
Optical signal pulse width	> 100 ns
Optical signal edges (10 to 90%)	< 20 ns

### ORDER GUIDE

Description	Catalog Listing
Standard screening, plastic package	HFD3023-002

This product is also available in special interface receptacles for interfacing to standard fiber optic cables.

# HFD3023

## 5 Mbit Direct Coupled Receiver

### FIBER INTERFACE

Honeywell detectors are designed to interface with multimode fibers with sizes (core/cladding diameters) ranging from 50/125 microns to 200/230 microns. Honeywell performs the final tests using 100/140 micron core fiber. The fiber chosen by the user will depend upon a number of application issues (distance, link budget, cable attenuation, splice attenuation, and safety margin). The 50/125 and 62.5/125 micron fibers have the advantages of high bandwidth and low cost, making them ideal for higher bandwidth installations. The use of 100/140 and 200/230 micron core fibers results in greater power being coupled by the transmitter, making it easier to splice or connect in bulkhead areas. Optical cables can be purchased from a number of sources.

### BLOCK DIAGRAM

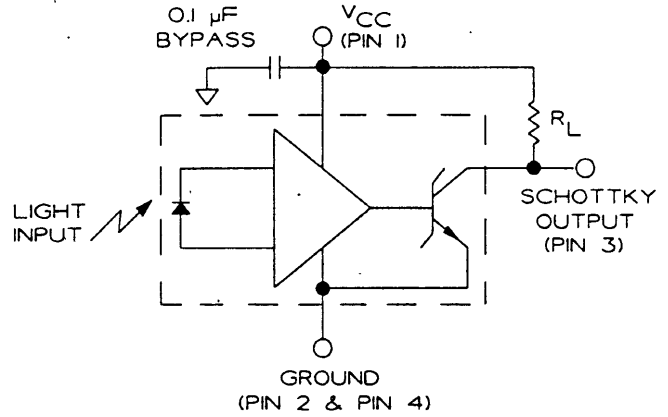

FIBER-4 SCH

### SWITCHING WAVEFORM

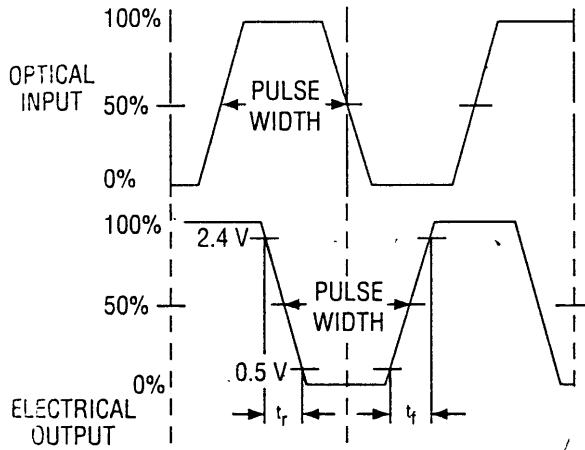

FIBER-4 CIR

FIBER-54 GRA

Fig. 1 Pulse Width Distortion vs Optical Input Power

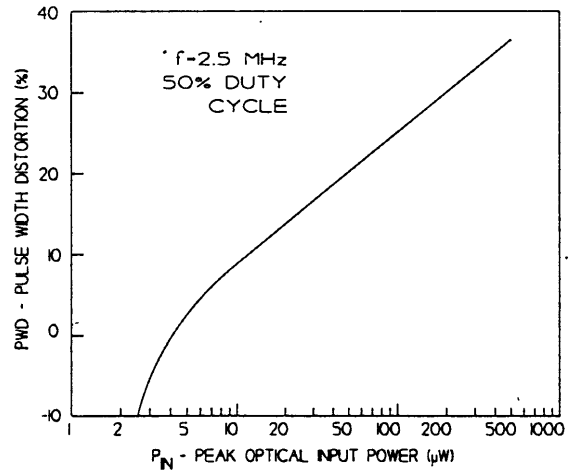
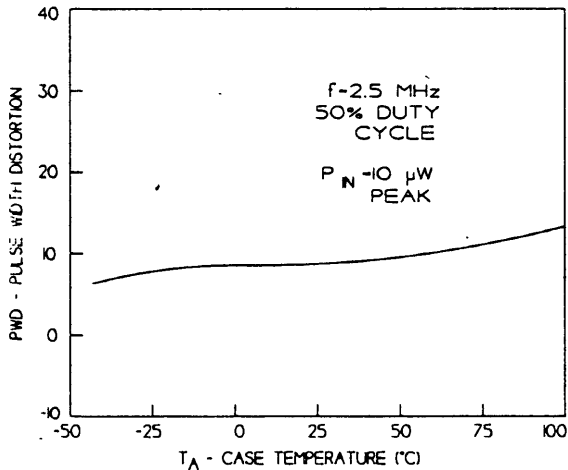

Fig. 2 Pulse Width Distortion vs Temperature



FIBER-55 GRA

FIBER-56 GRA

Fig. 3 Pulse Width Distortion vs Frequency

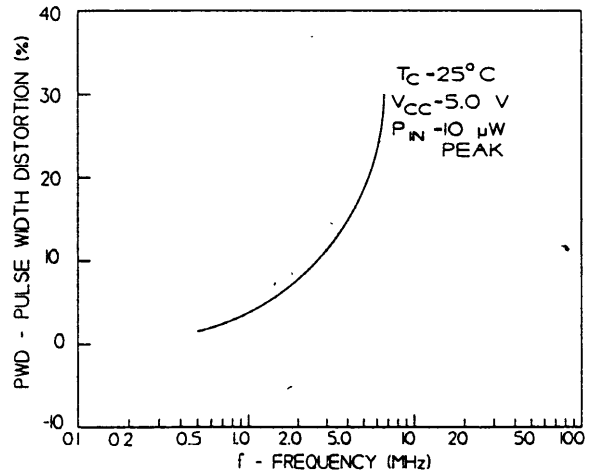

All Performance Curves Show Typical Values

Honeywell reserves the right to make changes in order to improve design and supply the best products possible.

# Honeywell

# HFD3023

## 5 Mbit Direct Coupled Receiver

Fig. 4 Propagation Delay Time vs Peak Optical Input Power

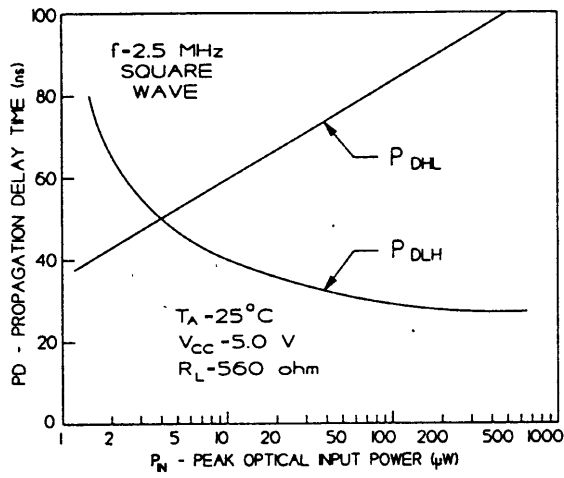

FIBER-57 GRA

**CAUTION:** The inherent design of this component causes it to be sensitive to electrostatic discharge (ESD). To prevent ESD-induced damage and/or degradation to equipment, take normal ESD precautions when handling this product.

