



eZ80Acclaim!™ Flash Microcontrollers

eZ80F91 MCU

Product Specification

PS019209-0504

PRELIMINARY

ZiLOG Worldwide Headquarters • 532 Race Street • San Jose, CA 95126
Telephone: 408.558.8500 • Fax: 408.558.8300 • www.ZiLOG.com



This publication is subject to replacement by a later edition. To determine whether a later edition exists, or to request copies of publications, contact:

ZiLOG Worldwide Headquarters

532 Race Street

San Jose, CA 95126

Telephone: 408.558.8500

Fax: 408.558.8300

www.ZiLOG.com

ZiLOG is a registered trademark of ZiLOG Inc. in the United States and in other countries. All other products and/or service names mentioned herein may be trademarks of the companies with which they are associated.

Document Disclaimer

©2004 by ZiLOG, Inc. All rights reserved. Information in this publication concerning the devices, applications, or technology described is intended to suggest possible uses and may be superseded. ZiLOG, INC. DOES NOT ASSUME LIABILITY FOR OR PROVIDE A REPRESENTATION OF ACCURACY OF THE INFORMATION, DEVICES, OR TECHNOLOGY DESCRIBED IN THIS DOCUMENT. ZiLOG ALSO DOES NOT ASSUME LIABILITY FOR INTELLECTUAL PROPERTY INFRINGEMENT RELATED IN ANY MANNER TO USE OF INFORMATION, DEVICES, OR TECHNOLOGY DESCRIBED HEREIN OR OTHERWISE. Except with the express written approval ZiLOG, use of information, devices, or technology as critical components of life support systems is not authorized. No licenses or other rights are conveyed, implicitly or otherwise, by this document under any intellectual property rights.



Table of Contents

| | |
|---|------|
| List of Figures | xiii |
| List of Tables | xiv |
| Architectural Overview | 1 |
| Features | 1 |
| Block Diagram | 2 |
| Pin Description | 4 |
| Pin Characteristics | 6 |
| System Clock Source Options | 33 |
| SCLK Source Selection Example | 34 |
| Register Map | 35 |
| eZ80 [®] CPU Core | 50 |
| Features | 50 |
| New Instructions | 50 |
| Reset | 51 |
| Reset Operation | 51 |
| External Reset Input and Indicator | 51 |
| Power-On Reset | 52 |
| Voltage Brown-Out Reset | 52 |
| Low Power Modes | 54 |
| Overview | 54 |
| SLEEP Mode | 54 |
| HALT Mode | 54 |
| HALT Mode and the EMAC Function | 55 |
| Clock Peripheral Power-Down Registers | 55 |
| General-Purpose Input/Output | 58 |
| GPIO Overview | 58 |
| GPIO Operation | 58 |
| GPIO Interrupts | 61 |
| Level-Triggered Interrupts | 61 |
| Edge-Triggered Interrupts | 62 |
| GPIO Control Registers | 62 |
| Port x Data Registers | 62 |
| Port x Data Direction Registers | 63 |
| Port x Alternate Register 1 | 63 |
| Port x Alternate Register 2 | 64 |
| Interrupt Controller | 65 |
| Maskable Interrupts | 65 |
| Interrupt Priority Registers | 68 |
| GPIO Port Interrupts | 72 |



| | |
|--|-----|
| Chip Selects and Wait States | 73 |
| Memory and I/O Chip Selects | 73 |
| Memory Chip Select Operation | 73 |
| Memory Chip Select Priority | 74 |
| Reset States | 74 |
| Memory Chip Select Example | 74 |
| I/O Chip Select Operation | 76 |
| Wait States | 76 |
| WAIT Input Signal | 77 |
| Chip Selects During Bus Request/Bus Acknowledge Cycles | 78 |
| Bus Mode Controller | 78 |
| eZ80 Bus Mode | 79 |
| Z80 Bus Mode | 79 |
| Intel Bus Mode | 81 |
| Intel Bus Mode—Separate Address and Data Buses | 82 |
| Intel™ Bus Mode—Multiplexed Address and Data Bus | 86 |
| Motorola Bus Mode | 88 |
| Switching Between Bus Modes | 92 |
| Chip Select Registers | 93 |
| Chip Select x Lower Bound Register | 93 |
| Chip Select x Upper Bound Register | 94 |
| Chip Select x Control Register | 95 |
| Chip Select x Bus Mode Control Register | 96 |
| Bus Arbiter | 98 |
| Random Access Memory | 101 |
| RAM Control Registers | 102 |
| RAM Control Register | 102 |
| RAM Address Upper Byte Register | 103 |
| MBIST Control | 104 |
| Flash Memory | 105 |
| Flash Memory Arrangement in the eZ80F91 Device | 105 |
| Flash Memory Overview | 106 |
| Reading Flash Memory | 106 |
| Memory Read | 107 |
| I/O Read | 107 |
| Programming Flash Memory | 107 |
| Single-Byte I/O Write | 107 |
| Multibyte I/O Write (Row Programming) | 108 |
| Memory Write | 109 |
| Erasing Flash Memory | 109 |
| Mass Erase | 109 |
| Page Erase | 109 |
| Information Page Characteristics | 110 |
| Flash Control Registers | 110 |



| | |
|---|-----|
| Flash Key Register | 110 |
| Flash Data Register | 111 |
| Flash Address Upper Byte Register | 112 |
| Flash Control Register | 113 |
| Flash Frequency Divider Register | 114 |
| Flash Write/Erase Protection Register | 115 |
| Flash Interrupt Control Register | 116 |
| Flash Page Select Register | 118 |
| Flash Row Select Register | 119 |
| Flash Column Select Register | 120 |
| Flash Program Control Register | 120 |
| Watch-Dog Timer | 122 |
| Watch-Dog Timer Overview | 122 |
| Watch-Dog Timer Operation | 123 |
| Enabling and Disabling the WDT | 123 |
| Time-Out Period Selection | 123 |
| RESET Or NMI Generation | 124 |
| Watch-Dog Timer Registers | 124 |
| Watch-Dog Timer Control Register | 124 |
| Watch-Dog Timer Reset Register | 126 |
| Programmable Reload Timers | 127 |
| Programmable Reload Timers Overview | 127 |
| Basic Timer Operation | 128 |
| Reading the Current Count Value | 128 |
| Setting Timer Duration | 128 |
| Single Pass Mode | 129 |
| Continuous Mode | 130 |
| Timer Interrupts | 130 |
| Timer Input Source Selection | 131 |
| Timer Output | 131 |
| Break Point Halting | 132 |
| Specialty Timer Modes | 133 |
| Event Counter | 133 |
| RTC Oscillator Input | 134 |
| Input Capture | 134 |
| Output Compare | 134 |
| Timer Port Pin Allocation | 135 |
| Timer Registers | 136 |
| Basic Timer Register Set | 136 |
| Register Set for Capture in Timer 1 | 136 |
| Register Set for Capture/Compare/PWM in Timer 3 | 137 |
| Timer Control Register | 138 |
| Timer Interrupt Enable Register | 139 |
| Timer Interrupt Identification Register | 141 |



| | |
|---|-----|
| Timer Data Register—Low Byte | 142 |
| Timer Data Register—High Byte | 142 |
| Timer Reload Register—Low Byte | 143 |
| Timer Reload Register—High Byte | 144 |
| Timer Input Capture Control Register | 144 |
| Timer Input Capture Value A Register—Low Byte | 145 |
| Timer Input Capture Value A Register—High Byte | 146 |
| Timer Input Capture Value B Register—Low Byte | 146 |
| Timer Input Capture Value B Register—High Byte | 147 |
| Timer Output Compare Control Register 1 | 147 |
| Timer Output Compare Control Register 2 | 148 |
| Timer Output Compare Value Register—Low Byte | 149 |
| Timer Output Compare Value Register—High Byte | 150 |
| Multi-PWM Mode | 150 |
| Multi-PWM Mode Overview | 150 |
| PWM Master Mode | 153 |
| Modification of Edge Transition Values | 153 |
| AND/OR Gating of the PWM Outputs | 154 |
| PWM Nonoverlapping Output Pair Delays | 155 |
| Multi-PWM Power-Trip Mode | 157 |
| Multi-PWM Control Registers | 158 |
| Pulse-Width Modulation Control Register 1 | 158 |
| Pulse-Width Modulation Control Register 2 | 159 |
| Pulse-Width Modulation Control Register 3 | 161 |
| Pulse-Width Modulation Rising Edge—Low Byte | 162 |
| Pulse-Width Modulation Rising Edge—High Byte | 163 |
| Pulse-Width Modulation Falling Edge—Low Byte | 164 |
| Pulse-Width Modulation Falling Edge—High Byte | 165 |
| Real-Time Clock | 166 |
| Real-Time Clock Overview | 166 |
| Real-Time Clock Alarm | 167 |
| Real-Time Clock Oscillator and Source Selection | 167 |
| Real-Time Clock Battery Backup | 167 |
| Real-Time Clock Recommended Operation | 167 |
| Real-Time Clock Registers | 168 |
| Real-Time Clock Seconds Register | 168 |
| Real-Time Clock Minutes Register | 169 |
| Real-Time Clock Hours Register | 170 |
| Real-Time Clock Day-of-the-Week Register | 171 |
| Real-Time Clock Day-of-the-Month Register | 172 |
| Real-Time Clock Month Register | 173 |
| Real-Time Clock Year Register | 174 |
| Real-Time Clock Century Register | 175 |
| Real-Time Clock Alarm Seconds Register | 176 |



| | |
|--|-----|
| Real-Time Clock Alarm Minutes Register | 177 |
| Real-Time Clock Alarm Hours Register | 178 |
| Real-Time Clock Alarm Day-of-the-Week Register | 179 |
| Real-Time Clock Alarm Control Register | 180 |
| Real-Time Clock Control Register | 181 |
| Universal Asynchronous Receiver/Transmitter | 183 |
| UART Functional Description | 184 |
| UART Functions | 184 |
| UART Transmitter | 184 |
| UART Receiver | 185 |
| UART Modem Control | 185 |
| UART Interrupts | 186 |
| UART Transmitter Interrupt | 186 |
| UART Receiver Interrupts | 186 |
| UART Modem Status Interrupt | 187 |
| UART Recommended Usage | 187 |
| Module Reset | 187 |
| Control Transfers | 187 |
| Data Transfers | 187 |
| Baud Rate Generator | 188 |
| BRG Control Registers | 189 |
| UART Baud Rate Generator Register—Low and High Bytes | 189 |
| UART Registers | 191 |
| UART Transmit Holding Register | 191 |
| UART Receive Buffer Register | 192 |
| UART Interrupt Enable Register | 192 |
| UART Interrupt Identification Register | 193 |
| UART FIFO Control Register | 195 |
| UART Line Control Register | 196 |
| UART Modem Control Register | 198 |
| UART Line Status Register | 200 |
| UART Modem Status Register | 202 |
| UART Scratch Pad Register | 203 |
| Infrared Encoder/Decoder | 204 |
| Functional Description | 204 |
| Transmit | 205 |
| Receive | 205 |
| Jitter | 206 |
| Infrared Encoder/Decoder Signal Pins | 206 |
| Loopback Testing | 207 |
| Infrared Encoder/Decoder Register | 207 |
| Serial Peripheral Interface | 209 |
| SPI Signals | 210 |



| | |
|--|-----|
| Master In, Slave Out | 210 |
| Master Out, Slave In | 210 |
| Slave Select | 210 |
| Serial Clock | 210 |
| SPI Functional Description | 212 |
| SPI Flags | 213 |
| Mode Fault | 213 |
| Write Collision | 213 |
| SPI Baud Rate Generator | 213 |
| Baud Rate Generator Functional Description | 213 |
| Data Transfer Procedure with SPI Configured as a Master | 214 |
| Data Transfer Procedure with SPI Configured as a Slave | 214 |
| SPI Registers | 214 |
| SPI Baud Rate Generator Registers—Low Byte and High Byte | 215 |
| SPI Control Register | 216 |
| SPI Status Register | 217 |
| SPI Transmit Shift Register | 217 |
| SPI Receive Buffer Register | 218 |
| I^2C Serial I/O Interface | 219 |
| I^2C General Characteristics | 219 |
| Clocking Overview | 219 |
| Bus Arbitration Overview | 219 |
| Data Validity | 220 |
| START and STOP Conditions | 220 |
| Transferring Data | 221 |
| Byte Format | 221 |
| Acknowledge | 221 |
| Clock Synchronization | 222 |
| Arbitration | 223 |
| Clock Synchronization for Handshake | 224 |
| Operating Modes | 224 |
| Master Transmit | 224 |
| Master Receive | 227 |
| Slave Transmit | 229 |
| Slave Receive | 230 |
| I^2C Registers | 231 |
| Addressing | 231 |
| Resetting the I^2C Registers | 231 |
| I^2C Slave Address Register | 232 |
| I^2C Extended Slave Address Register | 232 |
| I^2C Data Register | 233 |
| I^2C Control Register | 234 |
| I^2C Status Register | 236 |
| I^2C Clock Control Register | 238 |



| | |
|--|-----|
| Bus Clock Speed | 239 |
| I ² C Software Reset Register | 239 |
| Ethernet Media Access Controller | 240 |
| EMAC Functional Description | 241 |
| Memory | 241 |
| Arbiter | 242 |
| TxDMA | 242 |
| RxDMA | 243 |
| EMAC Interrupts | 244 |
| EMAC Shared Memory Organization | 245 |
| EMAC and the System Clock | 248 |
| EMAC Operation in HALT Modes | 249 |
| EMAC Registers | 249 |
| EMAC Test Register | 249 |
| EMAC Configuration Register 1 | 251 |
| EMAC Configuration Register 2 | 253 |
| EMAC Configuration Register 3 | 254 |
| EMAC Configuration Register 4 | 255 |
| EMAC Station Address Register | 256 |
| EMAC Transmit Pause Timer Value Register—Low and High Bytes | 257 |
| EMAC Interpacket Gap | 258 |
| EMAC Interpacket Gap Overview | 258 |
| EMAC Interpacket Gap Register | 259 |
| EMAC Non-Back-To-Back IPG Register—Part 1 | 260 |
| EMAC Non-Back-To-Back IPG Register—Part 2 | 261 |
| EMAC Maximum Frame Length Register—Low and High Bytes | 261 |
| EMAC Address Filter Register | 263 |
| EMAC Hash Table Register | 264 |
| EMAC MII Management Register | 265 |
| EMAC PHY Configuration Data Register—Low Byte | 266 |
| EMAC PHY Configuration Data Register—High Byte | 267 |
| EMAC PHY Address Register | 267 |
| EMAC PHY Unit Select Address Register | 268 |
| EMAC Transmit Polling Timer Register | 268 |
| EMAC Reset Control Register | 269 |
| EMAC Transmit Lower Boundary Pointer Register—Low and High Bytes | 270 |
| EMAC Boundary Pointer Register—Low and High Bytes | 271 |
| EMAC Boundary Pointer Register—Upper Byte | 272 |
| EMAC Receive High Boundary Pointer Register—Low and High Bytes | 272 |
| EMAC Receive Read Pointer Register—Low and High Bytes | 273 |
| EMAC Buffer Size Register | 274 |
| EMAC Interrupt Enable Register | 275 |



| | |
|--|-----|
| EMAC Interrupt Status Register | 277 |
| EMAC PHY Read Status Data Register—Low and High Bytes | 278 |
| EMAC MII Status Register | 279 |
| EMAC Receive Write Pointer Register—Low Byte | 280 |
| EMAC Receive Write Pointer Register—High Byte | 281 |
| EMAC Transmit Read Pointer Register—Low Byte | 281 |
| EMAC Transmit Read Pointer Register—High Byte | 282 |
| EMAC Receive Blocks Left Register—Low and High Bytes | 282 |
| EMAC FIFO Data Register—Low and High Bytes | 284 |
| EMAC FIFO Flags Register | 285 |
| ZiLOG Debug Interface | 286 |
| Introduction | 286 |
| ZDI-Supported Protocol | 287 |
| ZDI Clock and Data Conventions | 288 |
| ZDI Start Condition | 288 |
| ZDI Single-Bit Byte Separator | 289 |
| ZDI Register Addressing | 290 |
| ZDI Write Operations | 291 |
| ZDI Single-Byte Write | 291 |
| ZDI Block Write | 291 |
| ZDI Read Operations | 292 |
| ZDI Single-Byte Read | 292 |
| ZDI Block Read | 292 |
| Operation of the eZ80F91 Device during ZDI Break Points | 293 |
| Bus Requests During ZDI Debug Mode | 293 |
| Potential Hazards of Enabling Bus Requests During Debug Mode | 294 |
| ZDI Write Only Registers | 294 |
| ZDI Read Only Registers | 295 |
| ZDI Register Definitions | 296 |
| ZDI Address Match Registers | 296 |
| ZDI Break Control Register | 297 |
| ZDI Master Control Register | 299 |
| ZDI Write Data Registers | 300 |
| ZDI Read/Write Control Register | 300 |
| ZDI Bus Control Register | 302 |
| Instruction Store 4:0 Registers | 303 |
| ZDI Write Memory Register | 304 |
| eZ80 Product ID Low and High Byte Registers | 305 |
| eZ80 Product ID Revision Register | 306 |
| ZDI Status Register | 307 |
| ZDI Read Register Low, High, and Upper | 308 |
| ZDI Bus Status Register | 309 |
| ZDI Read Memory Register | 309 |



| | |
|---|-----|
| On-Chip Instrumentation | 311 |
| Introduction to On-Chip Instrumentation | 311 |
| OCI Activation | 312 |
| OCI Interface | 312 |
| JTAG Boundary Scan | 313 |
| Introduction | 313 |
| Pin Coverage | 313 |
| Boundary Scan Cell Functionality | 314 |
| Chain Sequence and Length | 314 |
| Usage | 319 |
| Boundary Scan Instructions | 319 |
| Phase-Locked Loop | 320 |
| Overview | 320 |
| Phase Frequency Detector | 321 |
| Charge Pump | 321 |
| Voltage Controlled Oscillator | 321 |
| Loop Filter | 321 |
| Divider | 321 |
| MUX/CLK Sync | 321 |
| Lock Detect | 322 |
| PLL Normal Operation | 322 |
| Power Requirement to the Phase-Locked Loop Function | 323 |
| PLL Registers | 323 |
| PLL Divider Control Register—Low and High Bytes | 323 |
| PLL Control Register 0 | 325 |
| PLL Control Register 1 | 326 |
| PLL Characteristics | 327 |
| eZ80 [®] CPU Instruction Set | 330 |
| Op-Code Map | 335 |
| On-Chip Oscillators | 342 |
| Primary Crystal Oscillator Operation | 342 |
| 32KHz Real-Time Clock Crystal Oscillator Operation | 343 |
| Electrical Characteristics | 345 |
| Absolute Maximum Ratings | 345 |
| DC Characteristics | 346 |
| POR and VBO Electrical Characteristics | 347 |
| Flash Memory Characteristics | 347 |
| AC Characteristics | 348 |
| External Memory Read Timing | 349 |
| External Memory Write Timing | 350 |
| External I/O Read Timing | 352 |
| External I/O Write Timing | 353 |
| Wait State Timing for Read Operations | 355 |



Wait State Timing for Write Operations 356
General Purpose I/O Port Input Sample Timing 357
General Purpose I/O Port Output Timing 357
External Bus Acknowledge Timing 358
External System Clock Driver Timing 358
Packaging 359
Ordering Information 361
 Part Number Description 361
 Precharacterization Product 362
Document Information 363
 Document Number Description 363
 Change Log 363
Index 364
Customer Feedback Form 379

www.DataSheet4U.com



List of Figures

| | |
|--|-----|
| Figure 1. GPIO Port Pin Block Diagram | 61 |
| Figure 2. Example: Memory Chip Select | 75 |
| Figure 3. Wait Input Sampling Block Diagram | 77 |
| Figure 4. Example: Z80 Bus Mode Read Timing | 80 |
| Figure 5. Example: Z80 Bus Mode Write Timing | 81 |
| Figure 6. Intel Bus Mode Signal and Pin Mapping | 82 |
| Figure 7. Motorola Bus Mode Signal and Pin Mapping | 89 |
| Figure 8. Example: eZ80F91 On-Chip RAM Memory Addressing | 101 |
| Figure 9. Programmable Reload Timer Block Diagram | 127 |
| Figure 10. PWM AND/OR Gating Functional Diagram | 155 |
| Figure 11. UART Block Diagram | 183 |
| Figure 12. SPI Master Device | 209 |
| Figure 13. SPI Slave Device | 209 |
| Figure 14. I ² C Clock and Data Relationship | 220 |
| Figure 15. START and STOP Conditions In I ² C Protocol | 220 |
| Figure 16. I ² C Frame Structure | 221 |
| Figure 17. I ² C Acknowledge | 222 |
| Figure 18. Clock Synchronization In I ² C Protocol | 223 |
| Figure 19. internal Ethernet Shared Memory | 245 |
| Figure 20. Descriptor Table | 246 |
| Figure 21. Descriptor Table Entries | 246 |
| Figure 22. Typical ZDI Debug Setup | 286 |
| Figure 23. Schematic For Building a Target Board ZPAK Connector | 287 |
| Figure 24. ZDI Write Timing | 289 |
| Figure 25. ZDI Read Timing | 289 |
| Figure 26. Normal PLL Programming Flow | 323 |
| Figure 27. Recommended Crystal Oscillator Configuration—50MHz Operation | 342 |
| Figure 28. Recommended Crystal Oscillator Configuration—32KHz Operation | 344 |
| Figure 29. External I/O Write Timing | 353 |
| Figure 30. Wait State Timing for Read Operations | 355 |
| Figure 31. Wait State Timing for Write Operations | 356 |

www.DataSheet4U.com



List of Tables

| | | |
|-----------|--|-----|
| Table 1. | Clock Peripheral Power-Down Register 1 | 56 |
| Table 2. | Clock Peripheral Power-Down Register 2 | 57 |
| Table 3. | Port x Data Direction Registers | 63 |
| Table 4. | Port x Alternate Registers 1 | 63 |
| Table 5. | Port x Data Registers | 63 |
| Table 6. | Port x Alternate Registers 2 | 64 |
| Table 7. | Interrupt Vector Sources by Priority | 65 |
| Table 8. | Interrupt Priority Registers | 69 |
| Table 9. | Interrupt Vector Priority Control Bits | 70 |
| Table 10. | Example: Maskable Interrupt Priority | 71 |
| Table 11. | Example: Priority Levels for Maskable Interrupts | 71 |
| Table 12. | Chip Select x Lower Bound Register | 93 |
| Table 13. | Chip Select x Upper Bound Register | 94 |
| Table 14. | Chip Select x Control Register | 95 |
| Table 15. | Chip Select x Bus Mode Control Register | 96 |
| Table 16. | eZ80F91 Pin Status During Bus Acknowledge Cycles | 98 |
| Table 17. | RAM Control Register | 102 |
| Table 18. | RAM Address Upper Byte Register | 103 |
| Table 19. | MBIST Control Register | 104 |
| Table 20. | Flash Key Register | 110 |
| Table 21. | Flash Data Register | 111 |
| Table 22. | Flash Address Upper Byte Register | 112 |
| Table 23. | Flash Control Register | 113 |
| Table 24. | Flash Frequency Divider Values | 114 |
| Table 25. | Flash Frequency Divider Register | 114 |
| Table 26. | Flash Write/Erase Protection Register | 115 |
| Table 27. | Flash Interrupt Control Register | 117 |
| Table 28. | Flash Page Select Register | 118 |
| Table 29. | Flash Row Select Register | 119 |
| Table 30. | Flash Column Select Register | 120 |
| Table 31. | Flash Program Control Register | 121 |
| Table 32. | Watch-Dog Timer Approximate Time-Out Delays | 123 |



| | |
|---|-----|
| Table 33. Watch-Dog Timer Approximate Time-Out Delays w/ Internal RC Oscillator | 123 |
| Table 34. Watch-Dog Timer Control Register. | 124 |
| Table 35. Watch-Dog Timer Reset Register. | 126 |
| Table 36. Example: PRT Single Pass Mode Parameters. | 129 |
| Table 37. Example : PRT Continuous Mode Parameters. | 130 |
| Table 38. Example: PRT Timer Out Parameters | 132 |
| Table 39. GPIO Mode Selection When Using Timer Pins | 135 |
| Table 40. Timer Control Register | 138 |
| Table 41. Timer Interrupt Enable | 139 |
| Table 42. Timer Interrupt Identification Register. | 141 |
| Table 43. Timer Data Register—Low Byte | 142 |
| Table 44. Timer Reload Register—Low Byte | 143 |
| Table 45. Timer Data Register—High Byte | 143 |
| Table 46. Timer Reload Register—High Byte. | 144 |
| Table 47. Timer Input Capture Control Register. | 144 |
| Table 48. Timer Input Capture Value Register A—Low Byte | 145 |
| Table 49. Timer Input Capture Value Register A—High Byte | 146 |
| Table 50. Timer Input Capture Value Register B—Low Byte | 146 |
| Table 51. Timer Input Capture Value Register B—High Byte | 147 |
| Table 52. Timer Output Compare Control Register 1. | 147 |
| Table 53. Timer Output Compare Control Register 2. | 148 |
| Table 54. Compare Value Register—Low Byte | 149 |
| Table 55. Compare Value Register—High Byte. | 150 |
| Table 56. Enabling PWM Generators. | 151 |
| Table 57. PWM Nonoverlapping Output Addressing | 156 |
| Table 58. PWM Control Register 1. | 158 |
| Table 59. PWM Control Register 2. | 159 |
| Table 60. PWM Control Register 3. | 161 |
| Table 61. PWMx Rising-Edge Register—Low Byte | 162 |
| Table 62. PWMx Rising-Edge Register—High Byte. | 163 |
| Table 63. PWMx Falling-Edge Register—Low Byte | 164 |
| Table 64. PWMx Falling-Edge Register—High Byte | 165 |
| Table 65. Real-Time Clock Seconds Register | 168 |
| Table 66. Real-Time Clock Minutes Register | 169 |
| Table 67. Real-Time Clock Hours Register | 170 |



| | | |
|------------|---|-----|
| Table 68. | Real-Time Clock Day-of-the-Week Register | 171 |
| Table 69. | Real-Time Clock Day-of-the-Month Register | 172 |
| Table 70. | Real-Time Clock Month Register | 173 |
| Table 71. | Real-Time Clock Year Register | 174 |
| Table 72. | Real-Time Clock Century Register | 175 |
| Table 73. | Real-Time Clock Alarm Seconds Register | 176 |
| Table 74. | Real-Time Clock Alarm Minutes Register | 177 |
| Table 75. | Real-Time Clock Alarm Hours Register | 178 |
| Table 76. | Real-Time Clock Alarm Day-of-the-Week Register | 179 |
| Table 77. | Real-Time Clock Alarm Control Register | 180 |
| Table 78. | Real-Time Clock Control Register | 181 |
| Table 79. | UART Baud Rate Generator Register—Low Bytes | 190 |
| Table 80. | UART Baud Rate Generator Register—High Bytes | 190 |
| Table 81. | UART Transmit Holding Registers | 191 |
| Table 82. | UART Receive Buffer Registers | 192 |
| Table 83. | UART Interrupt Enable Registers | 192 |
| Table 84. | UART Interrupt Identification Registers | 193 |
| Table 85. | UART Interrupt Status Codes | 194 |
| Table 86. | UART FIFO Control Registers | 195 |
| Table 87. | UART Line Control Registers | 196 |
| Table 88. | UART Character Parameter Definition | 197 |
| Table 89. | UART Modem Control Registers | 198 |
| Table 90. | Parity Select Definition for Multidrop Communications | 198 |
| Table 91. | UART Line Status Registers | 200 |
| Table 92. | UART Modem Status Registers | 202 |
| Table 93. | UART Scratch Pad Registers | 203 |
| Table 94. | Infrared Encoder/Decoder Control Registers | 207 |
| Table 95. | SPI Clock Phase and Clock Polarity Operation | 211 |
| Table 96. | SPI Baud Rate Generator Register—Low Byte | 215 |
| Table 97. | SPI Baud Rate Generator Register—High Byte | 215 |
| Table 98. | SPI Control Register | 216 |
| Table 99. | SPI Status Register | 217 |
| Table 100. | SPI Receive Buffer Register | 218 |
| Table 101. | SPI Transmit Shift Register | 218 |
| Table 102. | I ² C Master Transmit Status Codes | 225 |
| Table 103. | I ² C 10-Bit Master Transmit Status Codes | 226 |

www.DataSheet4U.com



| | |
|--|-----|
| Table 104. I ² C Master Transmit Status Codes For Data Bytes | 227 |
| Table 105. I ² C Master Receive Status Codes | 228 |
| Table 106. I ² C Master Receive Status Codes For Data Bytes | 229 |
| Table 107. I ² C Register Descriptions | 231 |
| Table 108. I ² C Slave Address Register | 232 |
| Table 109. I ² C Extended Slave Address Register | 233 |
| Table 110. I ² C Data Register | 233 |
| Table 111. I ² C Control Register | 235 |
| Table 112. I ² C Status Registers | 236 |
| Table 113. I ² C Status Codes | 236 |
| Table 114. I ² C Clock Control Registers | 238 |
| Table 115. I ² C Software Reset Register. | 239 |
| Table 116. Arbiter Priority. | 242 |
| Table 117. EMAC Test Register. | 250 |
| Table 118. EMAC Configuration Register 1 | 251 |
| Table 119. EMAC Configuration Register 2 | 253 |
| Table 120. EMAC Configuration Register 3 | 254 |
| Table 121. EMAC Configuration Register 4 | 255 |
| Table 122. EMAC Station Address Register. | 256 |
| Table 123. EMAC Transmit Pause Timer Value Register—Low Byte | 257 |
| Table 124. EMAC Transmit Pause Timer Value Register—High Byte | 257 |
| Table 125. EMAC_IPGT Non-Back-to-Back Settings for Full/Half Duplex Modes | 259 |
| Table 126. EMAC Non-Back-To-Back IPG Register—Part 1 | 260 |
| Table 127. EMAC Interpacket Gap Register | 260 |
| Table 128. EMAC Non-Back-To-Back IPG Register—Part 2 | 261 |
| Table 129. EMAC Maximum Frame Length Register—High Byte. | 262 |
| Table 130. EMAC Maximum Frame Length Register—Low Byte | 262 |
| Table 131. EMAC Address Filter Register. | 263 |
| Table 132. EMAC Hash Table Register. | 264 |
| Table 133. EMAC MII Management Register | 265 |
| Table 134. EMAC PHY Configuration Data Register—Low Byte | 266 |
| Table 135. EMAC PHY Configuration Data Register—High Byte | 267 |
| Table 136. EMAC PHY Address Register | 267 |
| Table 137. EMAC PHY Unit Select Address Register. | 268 |
| Table 138. EMAC Transmit Polling Timer Register. | 268 |

www.DataSheet4U.com



| | |
|--|-----|
| Table 139. EMAC Reset Control Register | 269 |
| Table 140. EMAC Transmit Lower Boundary Pointer Register—Low Byte . . . | 270 |
| Table 141. EMAC Transmit Lower Boundary Pointer Register—High Byte . . | 270 |
| Table 142. EMAC Boundary Pointer Register—Low Byte | 271 |
| Table 143. EMAC Boundary Pointer Register—High Byte | 271 |
| Table 144. EMAC Boundary Pointer Register—Upper Byte | 272 |
| Table 145. EMAC Receive High Boundary Pointer Register—Low Byte | 272 |
| Table 146. EMAC Receive Read Pointer Register—Low Byte | 273 |
| Table 147. EMAC Receive High Boundary Pointer Register—High Byte | 273 |
| Table 148. EMAC Receive Read Pointer Register—High Byte | 274 |
| Table 149. EMAC Buffer Size Register | 275 |
| Table 150. EMAC Interrupt Enable Register | 276 |
| Table 151. EMAC Interrupt Status Register | 277 |
| Table 152. EMAC PHY Read Status Data Register—Low Byte | 278 |
| Table 153. EMAC MII Status Register | 279 |
| Table 154. EMAC PHY Read Status Data Register—High Byte | 279 |
| Table 155. EMAC Receive Write Pointer Register—Low Byte | 280 |
| Table 156. EMAC Receive Write Pointer Register—High Byte | 281 |
| Table 157. EMAC Transmit Read Pointer Register—Low Byte | 281 |
| Table 158. EMAC Transmit Read Pointer Register—High Byte | 282 |
| Table 159. EMAC Receive Blocks Left Register—High Byte | 283 |
| Table 160. EMAC Receive Blocks Left Register—Low Byte | 283 |
| Table 161. EMAC FIFO Data Register—Low Byte | 284 |
| Table 162. EMAC FIFO Data Register—High Byte | 284 |
| Table 163. EMAC FIFO Flags Register | 285 |
| Table 164. Recommend ZDI Clock vs. System Clock Frequency | 287 |
| Table 165. ZDI Write Only Registers | 294 |
| Table 166. ZDI Address Match Registers | 296 |
| Table 167. ZDI Break Control Register | 297 |
| Table 168. ZDI Master Control Register | 299 |
| Table 169. ZDI Write Data Registers | 300 |
| Table 170. ZDI Read/Write Control Register Functions | 301 |
| Table 171. ZDI Bus Control Register | 302 |
| Table 172. Instruction Store 4:0 Registers | 304 |
| Table 173. eZ80 Product ID Low Byte Register | 305 |
| Table 174. ZDI Write Memory Register | 305 |

www.DataSheet4U.com



| | |
|---|-----|
| Table 175. eZ80 Product ID Revision Register | 306 |
| Table 176. eZ80 Product ID High Byte Register | 306 |
| Table 177. ZDI Status Register | 307 |
| Table 178. ZDI Read Register Low, High and Upper | 308 |
| Table 179. ZDI Bus Control Register | 309 |
| Table 180. ZDI Read Memory Register | 310 |
| Table 181. PLL Divider Register—Low Bytes. | 324 |
| Table 182. PLL Divider Register—High Bytes | 324 |
| Table 183. PLL Control Register 0 | 325 |
| Table 184. PLL Control Register 1 | 326 |
| Table 185. Arithmetic Instructions | 330 |
| Table 186. Bit Manipulation Instructions. | 330 |
| Table 187. Block Transfer and Compare Instructions | 330 |
| Table 188. Exchange Instructions | 331 |
| Table 189. Input/Output Instructions | 331 |
| Table 190. Load Instructions | 332 |
| Table 191. Logical Instructions. | 332 |
| Table 192. Processor Control Instructions | 332 |
| Table 193. Program Control Instructions | 333 |
| Table 194. Rotate and Shift Instructions | 333 |
| Table 195. Recommended Crystal Oscillator Specifications—1 MHz Operation | 343 |
| Table 196. Recommended Crystal Oscillator Specifications—10MHz Operation | 343 |
| Table 197. Recommended Crystal Oscillator Specifications—32KHz Operation | 344 |
| Table 198. Typical 144-LQFP Package Electrical Characteristics | 348 |
| Table 199. External Memory Read Timing | 349 |
| Table 200. External Memory Write Timing | 351 |
| Table 201. External I/O Read Timing | 352 |
| Table 202. External I/O Write Timing | 354 |
| Table 203. GPIO Port Output Timing | 358 |
| Table 204. Bus Acknowledge Timing | 358 |
| Table 205. PHI System Clock Timing. | 358 |

www.DataSheet4U.com

Architectural Overview

The eZ80F91 device is a member of ZiLOG's family of eZ80Acclaim!TM Flash Microcontrollers. The eZ80F91 is a high-speed single-cycle instruction-fetch microcontroller with a maximum clock speed of 50MHz. It can operate in Z80-compatible addressing mode (64KB) or full 24-bit addressing mode (16MB). The rich peripheral set of the eZ80F91 makes it suitable for a variety of applications, including industrial control, embedded communication, and point-of-sale terminals.

Features

- Single-cycle instruction fetch, high-performance, pipelined eZ80[®] CPU core¹
- 10/100 BaseT Ethernet Media Access Controller with Media-Independent Interface (MII)
- 256KB Flash memory and 16 KB SRAM (8KB user, 8 KB EMAC)
- Low power features including SLEEP mode, HALT mode, and selective peripheral power-down control
- Two UARTs with independent baud rate generators
- SPI with independent clock rate generator
- I²C with independent clock rate generator
- IrDA-compliant infrared encoder/decoder
- Glueless external peripheral interface with 4 Chip Selects, individual Wait State generators, and an external WAIT input pin—supports Z80-, Intel-, and Motorola-style buses
- Fixed-priority vectored interrupts (both internal and external) and interrupt controller
- Real-time clock with on-chip 32KHz oscillator, selectable 50/60Hz input, and separate V_{DD} pin for battery backup
- Four 16-bit Counter/Timers with prescalers and direct input/output drive
- Watch-Dog Timer with internal oscillator clocking option
- 32 bits of General-Purpose I/O
- OCITM and ZDI debug interfaces

1. For simplicity, the term eZ80[®] CPU is referred to as CPU for the bulk of this document.

- 1149.1-compatible JTAG
- 144-pin LQFP and BGA packages
- 3.0–3.6V supply voltage with 5V tolerant inputs
- Operating Temperature Range:
 - Standard: 0°C to +70°C
 - Extended: –40°C to +105°C

www.DataSheet4U.com

► **Note:** All signals with an an overline are active Low. For example, $\overline{B/W}$, for which WORD is active Low, and $\overline{B/W}$, for which BYTE is active Low.

Power connections follow these conventional descriptions:

| Connection | Circuit | Device |
|------------|----------|----------|
| Power | V_{CC} | V_{DD} |
| Ground | GND | V_{SS} |

Block Diagram

Figure 1 illustrates a block diagram of the eZ80F91 microcontroller.

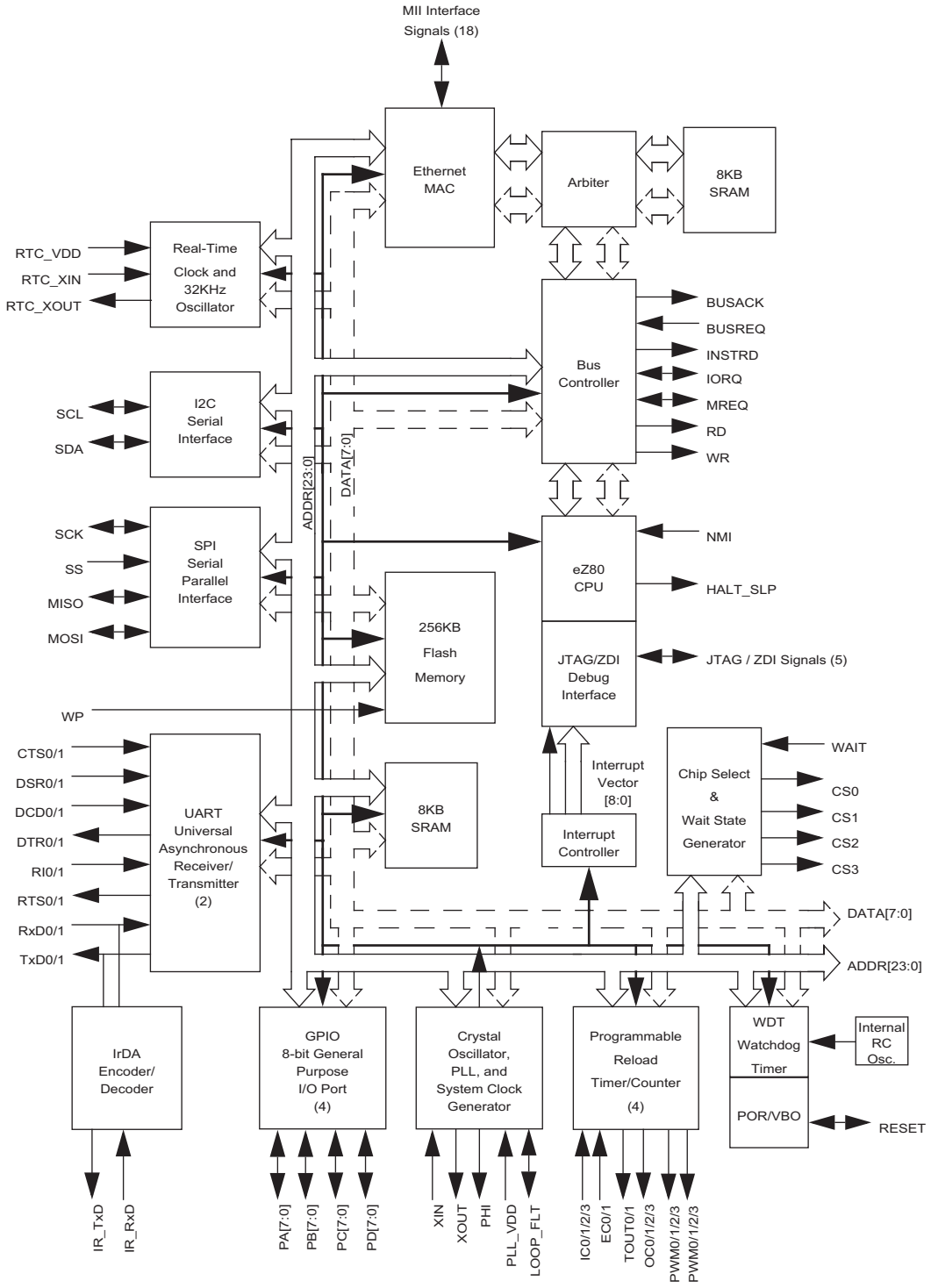



Pin Description

Table 1 details the pin configuration of the eZ80F91 device in the 144-ball BGA package.

Table 1. eZ80F91 144-Ball BGA Pin Configuration

| | 12 | 11 | 10 | 9 | 8 | 7 | 6 | 5 | 4 | 3 | 2 | 1 |
|----------|------------------|-----------------|---------------------|-----------------------|-----------------|---------------------|---------------------|-------------------|-----------------|------------------|------------------|------------------|
| A | SDA | SCL | PA0 | PA4 | PA7 | COL | TxD0 | V _{DD} | Rx_DV | MDC | WPn | A0 |
| B | V _{SS} | PHI | PA1 | PA3 | V _{DD} | TxD3 | Tx_EN | V _{SS} | RxD1 | MDIO | A2 | A1 |
| C | PB6 | PB7 | V _{DD} | PA5 | V _{SS} | TxD2 | Tx_CLK | Rx_CLK | RxD3 | A3 | V _{SS} | V _{DD} |
| D | PB1 | PB3 | PB5 | V _{SS} | CRS | TxD1 | Rx_ER | RxD2 | A4 | A8 | A6 | A7 |
| E | PC7 | V _{DD} | PB0 | PB4 | PA2 | Tx_ER | RxD0 | A5 | A11 | V _{SS} | V _{DD} | A10 |
| F | PC3 | PC4 | PC5 | V _{SS} | PB2 | PA6 | A9 | A17 | A15 | A14 | A13 | A12 |
| G | V _{SS} | PC0 | PC1 | PC2 | PC6 | PLL_V _{SS} | V _{SS} | A23 | A20 | V _{SS} | V _{DD} | A16 |
| H | X _{OUT} | X _{IN} | PLL_V _{DD} | V _{DD} | PD7 | TMS | V _{SS} | D5 | V _{SS} | A21 | A19 | A18 |
| J | V _{SS} | V _{DD} | LOOP_FILT_OUT | PD4 | TRIGOUT | RTC_V _{DD} | NMI _{In} | WR _n | D2 | CS0 _n | V _{DD} | A22 |
| K | PD5 | PD6 | PD3 | TDI | V _{SS} | V _{DD} | RESET _n | RD _n | V _{DD} | D1 | CS2 _n | CS1 _n |
| L | PD1 | PD2 | TRST _n | TCK | RTC_XOUT | BUSACK _n | WAIT _n | MREQ _n | D6 | D4 | D0 | CS3 _n |
| M | PD0 | V _{SS} | TDO | HALT_SLP _n | RTC_XIN | BUSREQ _n | INSTRD _n | IORQ _n | D7 | D3 | V _{SS} | V _{DD} |



Figure 2 illustrates the pin layout of the eZ80F91 device in the 144-pin LQFP package.

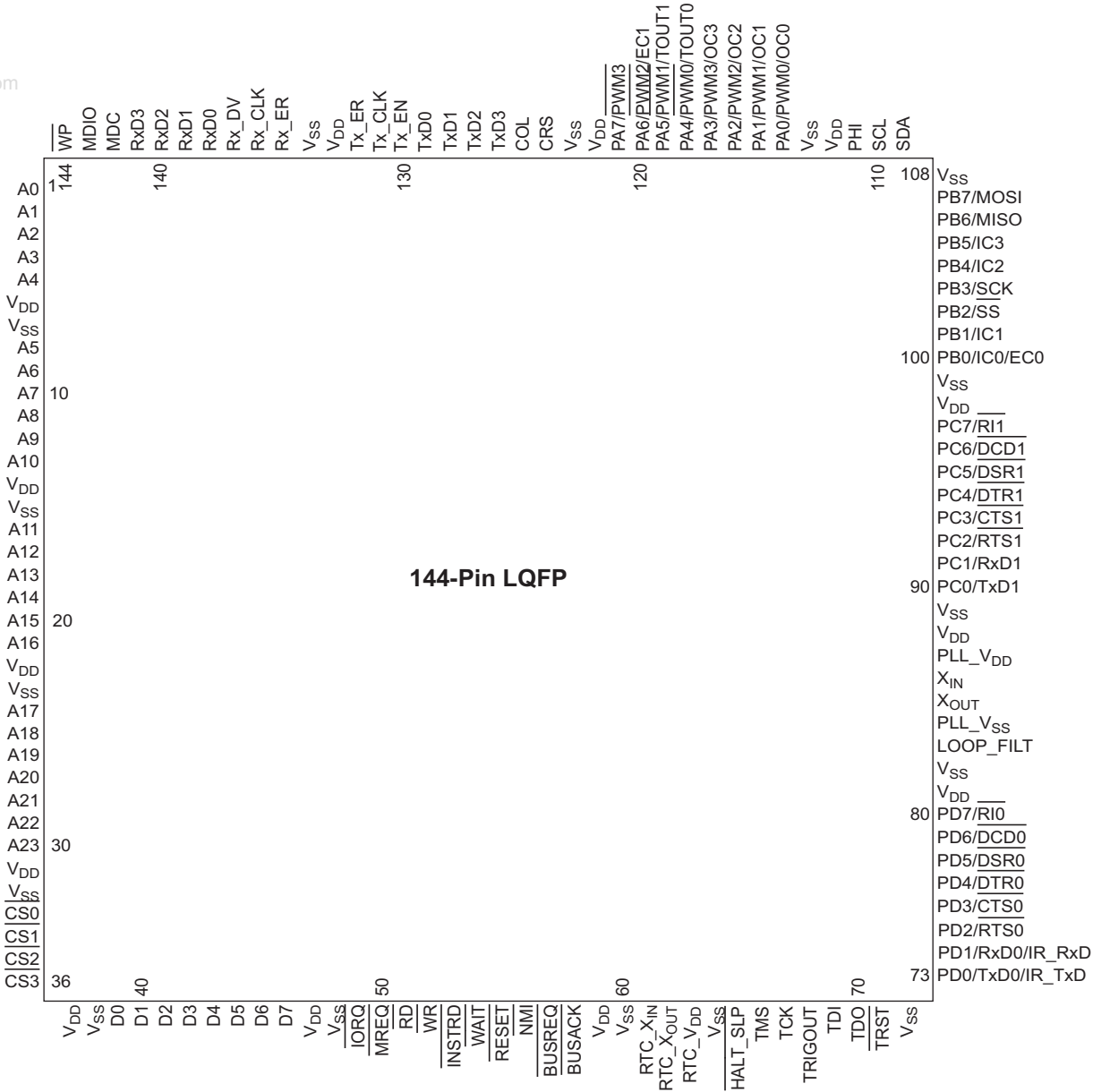

Figure 2. 144-Pin LQFP Configuration of the eZ80F91



Pin Characteristics

Table 2 describes the pins and functions of the eZ80F91 MCU's 144-pin LQFP package and 144-ball BGA package.

Table 2. Pin Identification on the eZ80F91 Device

| LQFP Pin # | BGA Pin# | Symbol | Function | Signal Direction | Description |
|------------|----------|--------|-------------|------------------|---|
| 1 | A1 | ADDR0 | Address Bus | Bidirectional | Configured as an output in normal operation. The address bus selects a location in memory or I/O space to be read or written. Configured as an input during bus acknowledge cycles. Drives the Chip Select/Wait State Generator block to generate Chip Selects. |
| 2 | B1 | ADDR1 | Address Bus | Bidirectional | Configured as an output in normal operation. The address bus selects a location in memory or I/O space to be read or written. Configured as an input during bus acknowledge cycles. Drives the Chip Select/Wait State Generator block to generate Chip Selects. |
| 3 | B2 | ADDR2 | Address Bus | Bidirectional | Configured as an output in normal operation. The address bus selects a location in memory or I/O space to be read or written. Configured as an input during bus acknowledge cycles. Drives the Chip Select/Wait State Generator block to generate Chip Selects. |
| 4 | C3 | ADDR3 | Address Bus | Bidirectional | Configured as an output in normal operation. The address bus selects a location in memory or I/O space to be read or written. Configured as an input during bus acknowledge cycles. Drives the Chip Select/Wait State Generator block to generate Chip Selects. |

Note: *PHY represents the physical layer of the OSI model.

Table 2. Pin Identification on the eZ80F91 Device (Continued)

| LQFP Pin # | BGA Pin# | Symbol | Function | Signal Direction | Description |
|------------|----------|-----------------|--------------|------------------|---|
| 5 | D4 | ADDR4 | Address Bus | Bidirectional | Configured as an output in normal operation. The address bus selects a location in memory or I/O space to be read or written. Configured as an input during bus acknowledge cycles. Drives the Chip Select/Wait State Generator block to generate Chip Selects. |
| 6 | C1 | V _{DD} | Power Supply | | Power Supply. |
| 7 | C2 | V _{SS} | Ground | | Ground. |
| 8 | E5 | ADDR5 | Address Bus | Bidirectional | Configured as an output in normal operation. The address bus selects a location in memory or I/O space to be read or written. Configured as an input during bus acknowledge cycles. Drives the Chip Select/Wait State Generator block to generate Chip Selects. |
| 9 | D2 | ADDR6 | Address Bus | Bidirectional | Configured as an output in normal operation. The address bus selects a location in memory or I/O space to be read or written. Configured as an input during bus acknowledge cycles. Drives the Chip Select/Wait State Generator block to generate Chip Selects. |
| 10 | D1 | ADDR7 | Address Bus | Bidirectional | Configured as an output in normal operation. The address bus selects a location in memory or I/O space to be read or written. Configured as an input during bus acknowledge cycles. Drives the Chip Select/Wait State Generator block to generate Chip Selects. |

Note: *PHY represents the physical layer of the OSI model.



Table 2. Pin Identification on the eZ80F91 Device (Continued)

| LQFP Pin # | BGA Pin# | Symbol | Function | Signal Direction | Description |
|------------|----------|-----------------|--------------|------------------|---|
| 11 | D3 | ADDR8 | Address Bus | Bidirectional | Configured as an output in normal operation. The address bus selects a location in memory or I/O space to be read or written. Configured as an input during bus acknowledge cycles. Drives the Chip Select/Wait State Generator block to generate Chip Selects. |
| 12 | F6 | ADDR9 | Address Bus | Bidirectional | Configured as an output in normal operation. The address bus selects a location in memory or I/O space to be read or written. Configured as an input during bus acknowledge cycles. Drives the Chip Select/Wait State Generator block to generate Chip Selects. |
| 13 | E1 | ADDR10 | Address Bus | Bidirectional | Configured as an output in normal operation. The address bus selects a location in memory or I/O space to be read or written. Configured as an input during bus acknowledge cycles. Drives the Chip Select/Wait State Generator block to generate Chip Selects. |
| 14 | E2 | V _{DD} | Power Supply | | Power Supply. |
| 15 | E3 | V _{SS} | Ground | | Ground. |
| 16 | E4 | ADDR11 | Address Bus | Bidirectional | Configured as an output in normal operation. The address bus selects a location in memory or I/O space to be read or written. Configured as an input during bus acknowledge cycles. Drives the Chip Select/Wait State Generator block to generate Chip Selects. |

Note: *PHY represents the physical layer of the OSI model.



Table 2. Pin Identification on the eZ80F91 Device (Continued)

| LQFP Pin # | BGA Pin# | Symbol | Function | Signal Direction | Description |
|---------------|-------------|--------|-------------|------------------|---|
| 17 | F1 | ADDR12 | Address Bus | Bidirectional | Configured as an output in normal operation. The address bus selects a location in memory or I/O space to be read or written. Configured as an input during bus acknowledge cycles. Drives the Chip Select/Wait State Generator block to generate Chip Selects. |
| 18 | F2 | ADDR13 | Address Bus | Bidirectional | Configured as an output in normal operation. The address bus selects a location in memory or I/O space to be read or written. Configured as an input during bus acknowledge cycles. Drives the Chip Select/Wait State Generator block to generate Chip Selects. |
| 19 | F3 | ADDR14 | Address Bus | Bidirectional | Configured as an output in normal operation. The address bus selects a location in memory or I/O space to be read or written. Configured as an input during bus acknowledge cycles. Drives the Chip Select/Wait State Generator block to generate Chip Selects. |
| 20 | F4 | ADDR15 | Address Bus | Bidirectional | Configured as an output in normal operation. The address bus selects a location in memory or I/O space to be read or written. Configured as an input during bus acknowledge cycles. Drives the Chip Select/Wait State Generator block to generate Chip Selects. |

Note: *PHY represents the physical layer of the OSI model.



Table 2. Pin Identification on the eZ80F91 Device (Continued)

| LQFP Pin # | BGA Pin# | Symbol | Function | Signal Direction | Description |
|---------------|-------------|-----------------|--------------|------------------|---|
| 21 | G1 | ADDR16 | Address Bus | Bidirectional | Configured as an output in normal operation. The address bus selects a location in memory or I/O space to be read or written. Configured as an input during bus acknowledge cycles. Drives the Chip Select/Wait State Generator block to generate Chip Selects. |
| 22 | G2 | V _{DD} | Power Supply | | Power Supply. |
| 23 | G3 | V _{SS} | Ground | | Ground. |
| 24 | F5 | ADDR17 | Address Bus | Bidirectional | Configured as an output in normal operation. The address bus selects a location in memory or I/O space to be read or written. Configured as an input during bus acknowledge cycles. Drives the Chip Select/Wait State Generator block to generate Chip Selects. |
| 25 | H1 | ADDR18 | Address Bus | Bidirectional | Configured as an output in normal operation. The address bus selects a location in memory or I/O space to be read or written. Configured as an input during bus acknowledge cycles. Drives the Chip Select/Wait State Generator block to generate Chip Selects. |
| 26 | H2 | ADDR19 | Address Bus | Bidirectional | Configured as an output in normal operation. The address bus selects a location in memory or I/O space to be read or written. Configured as an input during bus acknowledge cycles. Drives the Chip Select/Wait State Generator block to generate Chip Selects. |

Note: *PHY represents the physical layer of the OSI model.



Table 2. Pin Identification on the eZ80F91 Device (Continued)

| LQFP Pin # | BGA Pin# | Symbol | Function | Signal Direction | Description |
|------------|----------|-----------------|---------------|--------------------|---|
| 27 | G4 | ADDR20 | Address Bus | Bidirectional | Configured as an output in normal operation. The address bus selects a location in memory or I/O space to be read or written. Configured as an input during bus acknowledge cycles. Drives the Chip Select/Wait State Generator block to generate Chip Selects. |
| 28 | H3 | ADDR21 | Address Bus | Bidirectional | Configured as an output in normal operation. The address bus selects a location in memory or I/O space to be read or written. Configured as an input during bus acknowledge cycles. Drives the Chip Select/Wait State Generator block to generate Chip Selects. |
| 29 | J1 | ADDR22 | Address Bus | Bidirectional | Configured as an output in normal operation. The address bus selects a location in memory or I/O space to be read or written. Configured as an input during bus acknowledge cycles. Drives the Chip Select/Wait State Generator block to generate Chip Selects. |
| 30 | G5 | ADDR23 | Address Bus | Bidirectional | Configured as an output in normal operation. The address bus selects a location in memory or I/O space to be read or written. Configured as an input during bus acknowledge cycles. Drives the Chip Select/Wait State Generator block to generate Chip Selects. |
| 31 | J2 | V _{DD} | Power Supply | | Power Supply. |
| 32 | H4 | V _{SS} | Ground | | Ground. |
| 33 | J3 | CS0 | Chip Select 0 | Output, Active Low | CS0 Low indicates that an access is occurring in the defined CS0 memory or I/O address space. |

Note: *PHY represents the physical layer of the OSI model.



Table 2. Pin Identification on the eZ80F91 Device (Continued)

| LQFP Pin # | BGA Pin# | Symbol | Function | Signal Direction | Description |
|------------|----------|-----------------|---------------|--------------------|--|
| 34 | K1 | CS1 | Chip Select 1 | Output, Active Low | CS1 Low indicates that an <u>access</u> is occurring in the defined CS1 memory or I/O address space. |
| 35 | K2 | CS2 | Chip Select 2 | Output, Active Low | CS2 Low indicates that an <u>access</u> is occurring in the defined CS2 memory or I/O address space. |
| 36 | L1 | CS3 | Chip Select 3 | Output, Active Low | CS3 Low indicates that an <u>access</u> is occurring in the defined CS3 memory or I/O address space. |
| 37 | M1 | V _{DD} | Power Supply | | Power Supply. |
| 38 | M2 | V _{SS} | Ground | | Ground. |
| 39 | L2 | DATA0 | Data Bus | Bidirectional | The data bus transfers data to and from I/O and memory devices. The eZ80F91 drives these lines only during Write cycles when the eZ80F91 is the bus master. |
| 40 | K3 | DATA1 | Data Bus | Bidirectional | The data bus transfers data to and from I/O and memory devices. The eZ80F91 drives these lines only during Write cycles when the eZ80F91 device is the bus master. |
| 41 | J4 | DATA2 | Data Bus | Bidirectional | The data bus transfers data to and from I/O and memory devices. The eZ80F91 drives these lines only during Write cycles when the eZ80F91 is the bus master. |
| 42 | M3 | DATA3 | Data Bus | Bidirectional | The data bus transfers data to and from I/O and memory devices. The eZ80F91 drives these lines only during Write cycles when the eZ80F91 is the bus master. |

Note: *PHY represents the physical layer of the OSI model.



Table 2. Pin Identification on the eZ80F91 Device (Continued)

| LQFP Pin # | BGA Pin# | Symbol | Function | Signal Direction | Description |
|------------|----------|-----------------|----------------------|---------------------------|---|
| 43 | L3 | DATA4 | Data Bus | Bidirectional | The data bus transfers data to and from I/O and memory devices. The eZ80F91 drives these lines only during Write cycles when the eZ80F91 is the bus master. |
| 44 | H5 | DATA5 | Data Bus | Bidirectional | The data bus transfers data to and from I/O and memory devices. The eZ80F91 drives these lines only during Write cycles when the eZ80F91 is the bus master. |
| 45 | L4 | DATA6 | Data Bus | Bidirectional | The data bus transfers data to and from I/O and memory devices. The eZ80F91 drives these lines only during Write cycles when the eZ80F91 is the bus master. |
| 46 | M4 | DATA7 | Data Bus | Bidirectional | The data bus transfers data to and from I/O and memory devices. The eZ80F91 drives these lines only during Write cycles when the eZ80F91 is the bus master. |
| 47 | K4 | V _{DD} | Power Supply | | Power Supply. |
| 48 | G6 | V _{SS} | Ground | | Ground. |
| 49 | M5 | IORQ | Input/Output Request | Bidirectional, Active Low | IORQ indicates that the CPU is <u>accessing a</u> location in I/O space. RD and WR indicate the type of access. The eZ80F91 device does not drive this line during RESET. It is an input in bus acknowledge cycles. |

Note: *PHY represents the physical layer of the OSI model.



Table 2. Pin Identification on the eZ80F91 Device (Continued)

| LQFP Pin # | BGA Pin# | Symbol | Function | Signal Direction | Description |
|------------|----------|----------------------------|----------------------------|-----------------------------------|--|
| 50 | L5 | $\overline{\text{MREQ}}$ | Memory Request | Bidirectional, Active Low | $\overline{\text{MREQ}}$ Low indicates that the CPU is accessing a location in memory. The RD, WR, and INSTRD signals indicate the type of access. The eZ80F91 device does not drive this line during RESET. It is an input in bus acknowledge cycles. |
| 51 | K5 | $\overline{\text{RD}}$ | Read | Output, Active Low | $\overline{\text{RD}}$ Low indicates that the eZ80F91 device is reading from the current address location. This pin is tristated during bus acknowledge cycles. |
| 52 | J5 | $\overline{\text{WR}}$ | Write | Output, Active Low | $\overline{\text{WR}}$ indicates that the CPU is writing to the current address location. This pin is tristated during bus acknowledge cycles. |
| 53 | M6 | $\overline{\text{INSTRD}}$ | Instruction Read Indicator | Output, Active Low | $\overline{\text{INSTRD}}$ (with $\overline{\text{MREQ}}$ and $\overline{\text{RD}}$) indicates the eZ80F91 device is fetching an instruction from memory. This pin is tristated during bus acknowledge cycles. |
| 54 | L6 | $\overline{\text{WAIT}}$ | WAIT Request | Schmitt-trigger input, Active Low | Driving the $\overline{\text{WAIT}}$ pin Low forces the CPU to wait additional clock cycles for an external peripheral or external memory to complete its Read or Write operation. |
| 55 | K6 | $\overline{\text{RESET}}$ | Reset | Schmitt-trigger input, Active Low | This signal is used to initialize the eZ80F91 device. This input must be Low for a minimum of 3 system clock cycles, and must be held Low until the clock is stable. This input includes a Schmitt trigger to allow RC rise times. |

Note: *PHY represents the physical layer of the OSI model.



Table 2. Pin Identification on the eZ80F91 Device (Continued)

| LQFP Pin # | BGA Pin# | Symbol | Function | Signal Direction | Description |
|------------|----------|----------------------|--------------------------------|-----------------------------------|--|
| 56 | J6 | <u>NMI</u> | Nonmaskable Interrupt | Schmitt-trigger input, Active Low | The NMI input is a higher priority input than the maskable interrupts. It is always recognized at the end of an instruction, regardless of the state of the interrupt enable control bits. This input includes a Schmitt trigger to allow RC rise times. |
| 57 | M7 | <u>BUSREQ</u> | Bus Request | Schmitt-trigger input, Active Low | External devices can request the eZ80F91 device to release the memory interface bus for their use, by driving this pin Low. |
| 58 | L7 | <u>BUSACK</u> | Bus Acknowledge | Output, Active Low | The eZ80F91 device responds to a Low on BUSREQ, by tristating the address, data, and control signals, and by driving the BUSACK line Low. During bus acknowledge cycles ADDR[23:0], IORQ, and MREQ are inputs. |
| 59 | K7 | V _{DD} | Power Supply | | Power Supply. |
| 60 | H6 | V _{SS} | Ground | | Ground. |
| 61 | M8 | RTC_X _{IN} | Real-Time Clock Crystal Input | Input | This pin is the input to the low-power 32KHz crystal oscillator for the Real-Time Clock. |
| 62 | L8 | RTC_X _{OUT} | Real-Time Clock Crystal Output | Bidirectional | This pin is the output from the low-power 32KHz crystal oscillator for the Real-Time Clock. This pin is an input when the RTC is configured to operate from 50/60Hz input clock signals and the 32KHz crystal oscillator is disabled. |

Note: *PHY represents the physical layer of the OSI model.



Table 2. Pin Identification on the eZ80F91 Device (Continued)

| LQFP Pin # | BGA Pin# | Symbol | Function | Signal Direction | Description |
|------------|----------|---------------------|------------------------------|-----------------------------------|---|
| 63 | J7 | RTC_V _{DD} | Real-Time Clock Power Supply | | Power supply for the Real-Time Clock and associated 32KHz oscillator. Isolated from the power supply to the remainder of the chip. A battery can be connected to this pin to supply constant power to the Real-Time Clock and 32KHz oscillator. |
| 64 | K8 | V _{SS} | Ground | | Ground. |
| 65 | M9 | HALT_SLP | HALT and SLEEP Indicator | Output, Active Low | A Low on this pin indicates that the CPU has entered either HALT or SLEEP mode because of execution of either a HALT or SLP instruction. |
| 66 | H7 | TMS | JTAG Test Mode Select | Input | JTAG Mode Select Input. |
| 67 | L9 | TCK | JTAG Test Clock | Input | JTAG and ZDI clock input. |
| 68 | J8 | TRIGOUT | JTAG Test Trigger Output | Output | Active High trigger event indicator. |
| 69 | K9 | TDI | JTAG Test Data In | Bidirectional | JTAG data input pin. Functions as ZDI data I/O pin when JTAG is disabled. |
| 70 | M10 | TDO | JTAG Test Data Out | Output | JTAG data output pin. |
| 71 | L10 | TRST | JTAG Reset | Schmitt-trigger input, Active Low | JTAG reset input pin. |
| 72 | M11 | V _{SS} | Ground | | Ground. |

Note: *PHY represents the physical layer of the OSI model.



Table 2. Pin Identification on the eZ80F91 Device (Continued)

| LQFP Pin # | BGA Pin# | Symbol | Function | Signal Direction | Description |
|------------|----------|--------|--------------------|------------------|---|
| 73 | M12 | PD0 | GPIO Port D | Bidirectional | This pin can be used for general-purpose I/O. It can be individually programmed as input or output and can also be used individually as an interrupt input. Each Port D pin, when programmed as output, can be selected to be an open-drain or open-source output. Port D is multiplexed with one UART. |
| | | TxD0 | UART Transmit Data | Output | This pin is used by the UART to transmit asynchronous serial data. This signal is multiplexed with PD0. |
| | | IR_TxD | IrDA Transmit Data | Output | This pin is used by the IrDA encoder/decoder to transmit serial data. This signal is multiplexed with PD0. |
| 74 | L12 | PD1 | GPIO Port D | Bidirectional | This pin can be used for general-purpose I/O. It can be individually programmed as input or output and can also be used individually as an interrupt input. Each Port D pin, when programmed as output, can be selected to be an open-drain or open-source output. Port D is multiplexed with one UART. |
| | | RxD0 | Receive Data | Input | This pin is used by the UART to receive asynchronous serial data. This signal is multiplexed with PD1. |
| | | IR_RxD | IrDA Receive Data | Input | This pin is used by the IrDA encoder/decoder to receive serial data. This signal is multiplexed with PD1. |

Note: *PHY represents the physical layer of the OSI model.



Table 2. Pin Identification on the eZ80F91 Device (Continued)

| LQFP Pin # | BGA Pin# | Symbol | Function | Signal Direction | Description |
|------------|----------|--------|---------------------|--------------------|---|
| 75 | L11 | PD2 | GPIO Port D | Bidirectional | This pin can be used for general-purpose I/O. It can be individually programmed as input or output and can also be used individually as an interrupt input. Each Port D pin, when programmed as output, can be selected to be an open-drain or open-source output. Port D is multiplexed with one UART. |
| | | RTS0 | Request to Send | Output, Active Low | Modem control signal from UART. This signal is multiplexed with PD2. |
| 76 | K10 | PD3 | GPIO Port D | Bidirectional | This pin can be used for general-purpose I/O. It can be individually programmed as input or output and can also be used individually as an interrupt input. Each Port D pin, when programmed as output, can be selected to be an open-drain or open-source output. Port D is multiplexed with one UART. |
| | | CTS0 | Clear to Send | Input, Active Low | Modem status signal to the UART. This signal is multiplexed with PD3. |
| 77 | J9 | PD4 | GPIO Port D | Bidirectional | This pin can be used for general-purpose I/O. It can be individually programmed as input or output and can also be used individually as an interrupt input. Each Port D pin, when programmed as output, can be selected to be an open-drain or open-source output. Port D is multiplexed with one UART. |
| | | DTR0 | Data Terminal Ready | Output, Active Low | Modem control signal to the UART. This signal is multiplexed with PD4. |

Note: *PHY represents the physical layer of the OSI model.



Table 2. Pin Identification on the eZ80F91 Device (Continued)

| LQFP Pin # | BGA Pin# | Symbol | Function | Signal Direction | Description |
|------------|----------|-----------------|---------------------|-------------------|---|
| 78 | K12 | PD5 | GPIO Port D | Bidirectional | This pin can be used for general-purpose I/O. It can be individually programmed as input or output and can also be used individually as an interrupt input. Each Port D pin, when programmed as output, can be selected to be an open-drain or open-source output. Port D is multiplexed with one UART. |
| | | DSR0 | Data Set Ready | Input, Active Low | Modem status signal to the UART. This signal is multiplexed with PD5. |
| 79 | K11 | PD6 | GPIO Port D | Bidirectional | This pin can be used for general-purpose I/O. It can be individually programmed as input or output and can also be used individually as an interrupt input. Each Port D pin, when programmed as output, can be selected to be an open-drain or open-source output. Port D is multiplexed with one UART. |
| | | DCD0 | Data Carrier Detect | Input, Active Low | Modem status signal to the UART. This signal is multiplexed with PD6. |
| 80 | H8 | PD7 | GPIO Port D | Bidirectional | This pin can be used for general-purpose I/O. It can be individually programmed as input or output and can also be used individually as an interrupt input. Each Port D pin, when programmed as output, can be selected to be an open-drain or open-source output. Port D is multiplexed with one UART. |
| | | RI0 | Ring Indicator | Input, Active Low | Modem status signal to the UART. This signal is multiplexed with PD7. |
| 81 | J11 | V _{DD} | Power Supply | | Power Supply. |
| 82 | J12 | V _{SS} | Ground | | Ground. |

Note: *PHY represents the physical layer of the OSI model.



Table 2. Pin Identification on the eZ80F91 Device (Continued)

| LQFP Pin # | BGA Pin# | Symbol | Function | Signal Direction | Description |
|------------|----------|---------------------|--------------------------------|--|---|
| 83 | J10 | LOOP_FILT | PLL Loop Filter | Analog | Loop Filter pin for the Analog PLL. |
| 84 | G7 | PLL_V _{SS} | Ground | | Ground for Analog PLL. |
| 85 | H12 | X _{OUT} | System Clock Oscillator Output | Output | This pin is the output of the onboard crystal oscillator. When used, a crystal should be connected between X _{IN} and X _{OUT} . |
| 86 | H11 | X _{IN} | System Clock Oscillator Input | Input | This pin is the input to the onboard crystal oscillator for the primary system clock. If an external oscillator is used, its clock output should be connected to this pin. When a crystal is used, it should be connected between X _{IN} and X _{OUT} . |
| 87 | H10 | PLL_V _{DD} | Power Supply | | Power Supply for Analog PLL. |
| 88 | H9 | V _{DD} | Power Supply | | Power Supply. |
| 89 | G12 | V _{SS} | Ground | | Ground. |
| 90 | G11 | PC0 | GPIO Port C | Bidirectional with Schmitt-trigger input | This pin can be used for general-purpose I/O. It can be individually programmed as input or output and can also be used individually as an interrupt input. Each Port C pin, when programmed as output, can be selected to be an open-drain or open-source output. Port C is multiplexed with one UART. |
| | | TxD1 | Transmit Data | Output | This pin is used by the UART to transmit asynchronous serial data. This signal is multiplexed with PC0. |

Note: *PHY represents the physical layer of the OSI model.



Table 2. Pin Identification on the eZ80F91 Device (Continued)

| LQFP Pin # | BGA Pin# | Symbol | Function | Signal Direction | Description |
|---------------|-------------|--------|-----------------|--|---|
| 91 | G10 | PC1 | GPIO Port C | Bidirectional with Schmitt-trigger input | This pin can be used for general-purpose I/O. It can be individually programmed as input or output and can also be used individually as an interrupt input. Each Port C pin, when programmed as output, can be selected to be an open-drain or open-source output. Port C is multiplexed with one UART. |
| | | RxD1 | Receive Data | Schmitt-trigger input | This pin is used by the UART to receive asynchronous serial data. This signal is multiplexed with PC1. |
| 92 | G9 | PC2 | GPIO Port C | Bidirectional with Schmitt-trigger input | This pin can be used for general-purpose I/O. It can be individually programmed as input or output and can also be used individually as an interrupt input. Each Port C pin, when programmed as output, can be selected to be an open-drain or open-source output. Port C is multiplexed with one UART. |
| | | RTS1 | Request to Send | Output, Active Low | Modem control signal from UART. This signal is multiplexed with PC2. |
| 93 | F12 | PC3 | GPIO Port C | Bidirectional with Schmitt-trigger input | This pin can be used for general-purpose I/O. It can be individually programmed as input or output and can also be used individually as an interrupt input. Each Port C pin, when programmed as output, can be selected to be an open-drain or open-source output. Port C is multiplexed with one UART. |
| | | CTS1 | Clear to Send | Schmitt-trigger input, Active Low | Modem status signal to the UART. This signal is multiplexed with PC3. |

Note: *PHY represents the physical layer of the OSI model.



Table 2. Pin Identification on the eZ80F91 Device (Continued)

| LQFP Pin # | BGA Pin# | Symbol | Function | Signal Direction | Description |
|------------|----------|--------|---------------------|--|---|
| 94 | F11 | PC4 | GPIO Port C | Bidirectional with Schmitt-trigger input | This pin can be used for general-purpose I/O. It can be individually programmed as input or output and can also be used individually as an interrupt input. Each Port C pin, when programmed as output, can be selected to be an open-drain or open-source output. Port C is multiplexed with one UART. |
| | | DTR1 | Data Terminal Ready | Output, Active Low | Modem control signal to the UART. This signal is multiplexed with PC4. |
| 95 | F10 | PC5 | GPIO Port C | Bidirectional with Schmitt-trigger input | This pin can be used for general-purpose I/O. It can be individually programmed as input or output and can also be used individually as an interrupt input. Each Port C pin, when programmed as output, can be selected to be an open-drain or open-source output. Port C is multiplexed with one UART. |
| | | DSR1 | Data Set Ready | Schmitt-trigger input, Active Low | Modem status signal to the UART. This signal is multiplexed with PC5. |
| 96 | G8 | PC6 | GPIO Port C | Bidirectional with Schmitt-trigger input | This pin can be used for general-purpose I/O. It can be individually programmed as input or output and can also be used individually as an interrupt input. Each Port C pin, when programmed as output, can be selected to be an open-drain or open-source output. Port C is multiplexed with one UART. |
| | | DCD1 | Data Carrier Detect | Schmitt-trigger input, Active Low | Modem status signal to the UART. This signal is multiplexed with PC6. |

Note: *PHY represents the physical layer of the OSI model.



Table 2. Pin Identification on the eZ80F91 Device (Continued)

| LQFP Pin # | BGA Pin# | Symbol | Function | Signal Direction | Description |
|------------|----------|-----------------|----------------|--|---|
| 97 | E12 | PC7 | GPIO Port C | Bidirectional with Schmitt-trigger input | This pin can be used for general-purpose I/O. It can be individually programmed as input or output and can also be used individually as an interrupt input. Each Port C pin, when programmed as output, can be selected to be an open-drain or open-source output. Port C is multiplexed with one UART. |
| | | RI1 | Ring Indicator | Schmitt-trigger input, Active Low | Modem status signal to the UART. This signal is multiplexed with PC7. |
| 98 | E11 | V _{DD} | Power Supply | | Power Supply. |
| 99 | F9 | V _{SS} | Ground | | Ground. |
| 100 | E10 | PB0 | GPIO Port B | Bidirectional with Schmitt-trigger input | This pin can be used for general-purpose I/O. It can be individually programmed as input or output and can also be used individually as an interrupt input. Each Port B pin, when programmed as output, can be selected to be an open-drain or open-source output. |
| | | IC0 | Input Capture | Schmitt-trigger input | Input Capture A Signal to Timer 1. This signal is multiplexed with PB0. |
| | | EC0 | Event Counter | Schmitt-trigger input | Event Counter Signal to Timer 1. This signal is multiplexed with PB0. |

Note: *PHY represents the physical layer of the OSI model.



Table 2. Pin Identification on the eZ80F91 Device (Continued)

| LQFP Pin # | BGA Pin# | Symbol | Function | Signal Direction | Description |
|------------|----------|--------|------------------|--|--|
| 101 | D12 | PB1 | GPIO Port B | Bidirectional with Schmitt-trigger input | This pin can be used for general-purpose I/O. It can be individually programmed as input or output and can also be used individually as an interrupt input. Each Port B pin, when programmed as output, can be selected to be an open-drain or open-source output. |
| | | IC1 | Input Capture | Schmitt-trigger input | Input Capture B Signal to Timer 1. This signal is multiplexed with PB1. |
| 102 | F8 | PB2 | GPIO Port B | Bidirectional with Schmitt-trigger input | This pin can be used for general-purpose I/O. It can be individually programmed as input or output and can also be used individually as an interrupt input. Each Port B pin, when programmed as output, can be selected to be an open-drain or open-source output. |
| | | SS | SPI Slave Select | Schmitt-trigger input, Active Low | The slave select input line is used to select a slave device in SPI mode. This signal is multiplexed with PB2. |
| 103 | D11 | PB3 | GPIO Port B | Bidirectional with Schmitt-trigger input | This pin can be used for general-purpose I/O. It can be individually programmed as input or output and can also be used individually as an interrupt input. Each Port B pin, when programmed as output, can be selected to be an open-drain or open-source output. |
| | | SCK | SPI Serial Clock | Bidirectional with Schmitt-trigger input | SPI serial clock. This signal is multiplexed with PB3. |

Note: *PHY represents the physical layer of the OSI model.



Table 2. Pin Identification on the eZ80F91 Device (Continued)

| LQFP Pin # | BGA Pin# | Symbol | Function | Signal Direction | Description |
|---------------|-------------|--------|----------------------------|--|--|
| 104 | E9 | PB4 | GPIO Port B | Bidirectional with Schmitt-trigger input | This pin can be used for general-purpose I/O. It can be individually programmed as input or output and can also be used individually as an interrupt input. Each Port B pin, when programmed as output, can be selected to be an open-drain or open-source output. |
| | | IC2 | Input Capture | Schmitt-trigger input | Input Capture A Signal to Timer 3. This signal is multiplexed with PB4. |
| 105 | D10 | PB5 | GPIO Port B | Bidirectional with Schmitt-trigger input | This pin can be used for general-purpose I/O. It can be individually programmed as input or output and can also be used individually as an interrupt input. Each Port B pin, when programmed as output, can be selected to be an open-drain or open-source output. |
| | | IC3 | Input Capture | Schmitt-trigger input | Input Capture B Signal to Timer 3. This signal is multiplexed with PB5. |
| 106 | C12 | PB6 | GPIO Port B | Bidirectional with Schmitt-trigger input | This pin can be used for general-purpose I/O. It can be individually programmed as input or output and can also be used individually as an interrupt input. Each Port B pin, when programmed as output, can be selected to be an open-drain or open-source output. |
| | | MISO | SPI Master In Slave Out | Bidirectional with Schmitt-trigger input | The MISO line is configured as an input when the eZ80F91 device is an SPI master device and as an output when eZ80F91 is an SPI slave device. This signal is multiplexed with PB6. |

Note: *PHY represents the physical layer of the OSI model.



Table 2. Pin Identification on the eZ80F91 Device (Continued)

| LQFP Pin # | BGA Pin# | Symbol | Function | Signal Direction | Description |
|---------------|-------------|-----------------|-------------------------------|--|--|
| 107 | C11 | PB7 | GPIO Port B | Bidirectional with Schmitt-trigger input | This pin can be used for general-purpose I/O. It can be individually programmed as input or output and can also be used individually as an interrupt input. Each Port B pin, when programmed as output, can be selected to be an open-drain or open-source output. |
| | | MOSI | SPI Master Out Slave In | Bidirectional with Schmitt-trigger input | The MOSI line is configured as an output when the eZ80F91 device is an SPI master device and as an input when the eZ80F91 device is an SPI slave device. This signal is multiplexed with PB7. |
| 108 | B12 | V _{SS} | Ground | | Ground. |
| 109 | A12 | SDA | I ² C Serial Data | Bidirectional | This pin carries the I ² C data signal. |
| 110 | A11 | SCL | I ² C Serial Clock | Bidirectional | This pin is used to receive and transmit the I ² C clock. |
| 111 | B11 | PHI | System Clock | Output | This pin is an output driven by the internal system clock. It can be used by the system for synchronization with the eZ80F91 device. |
| 112 | C10 | V _{DD} | Power Supply | | Power Supply. |
| 113 | D9 | V _{SS} | Ground | | Ground. |

Note: *PHY represents the physical layer of the OSI model.



Table 2. Pin Identification on the eZ80F91 Device (Continued)

| LQFP Pin # | BGA Pin# | Symbol | Function | Signal Direction | Description |
|------------|----------|--------|------------------|------------------|--|
| 114 | A10 | PA0 | GPIO Port A | Bidirectional | This pin can be used for general-purpose I/O. It can be individually programmed as input or output and can also be used individually as an interrupt input. Each Port A pin, when programmed as output, can be selected to be an open-drain or open-source output. |
| | | PWM0 | PWM Output 0 | Output | This pin is used by Timer 3 for PWM 0. This signal is multiplexed with PA0. |
| | | OC0 | Output Compare 0 | Output | This pin is used by Timer 3 for Output Compare 0. This signal is multiplexed with PA0. |
| 115 | B10 | PA1 | GPIO Port A | Bidirectional | This pin can be used for general-purpose I/O. It can be individually programmed as input or output and can also be used individually as an interrupt input. Each Port A pin, when programmed as output, can be selected to be an open-drain or open-source output. |
| | | PWM1 | PWM Output 1 | Output | This pin is used by Timer 3 for PWM 1. This signal is multiplexed with PA1. |
| | | OC1 | Output Compare 1 | Output | This pin is used by Timer 3 for Output Compare 1. This signal is multiplexed with PA1. |

Note: *PHY represents the physical layer of the OSI model.



Table 2. Pin Identification on the eZ80F91 Device (Continued)

| LQFP Pin # | BGA Pin# | Symbol | Function | Signal Direction | Description |
|------------|----------|--------|------------------|------------------|--|
| 116 | E8 | PA2 | GPIO Port A | Bidirectional | This pin can be used for general-purpose I/O. It can be individually programmed as input or output and can also be used individually as an interrupt input. Each Port A pin, when programmed as output, can be selected to be an open-drain or open-source output. |
| | | PWM2 | PWM Output 2 | Output | This pin is used by Timer 3 for PWM 2. This signal is multiplexed with PA2. |
| | | OC2 | Output Compare 2 | Output | This pin is used by Timer 3 for Output Compare 2. This signal is multiplexed with PA2. |
| 117 | B9 | PA3 | GPIO Port A | Bidirectional | This pin can be used for general-purpose I/O. It can be individually programmed as input or output and can also be used individually as an interrupt input. Each Port A pin, when programmed as output, can be selected to be an open-drain or open-source output. |
| | | PWM3 | PWM Output 3 | Output | This pin is used by Timer 3 for PWM 3. This signal is multiplexed with PA3. |
| | | OC3 | Output Compare 3 | Output | This pin is used by Timer 3 for Output Compare 3 This signal is multiplexed with PA3. |

Note: *PHY represents the physical layer of the OSI model.



Table 2. Pin Identification on the eZ80F91 Device (Continued)

| LQFP Pin # | BGA Pin# | Symbol | Function | Signal Direction | Description |
|------------|----------|--------|-----------------------|------------------|--|
| 118 | A9 | PA4 | GPIO Port A | Bidirectional | This pin can be used for general-purpose I/O. It can be individually programmed as input or output and can also be used individually as an interrupt input. Each Port A pin, when programmed as output, can be selected to be an open-drain or open-source output. |
| | | PWM0 | PWM Output 0 Inverted | Output | This pin is used by Timer 3 for Negative PWM 0. This signal is multiplexed with PA4. |
| | | TOUT0 | Timer Out | Output | This pin is used by Timer 0 timer-out signal. This signal is multiplexed with PA4. |
| 119 | C9 | PA5 | GPIO Port A | Bidirectional | This pin can be used for general-purpose I/O. It can be individually programmed as input or output and can also be used individually as an interrupt input. Each Port A pin, when programmed as output, can be selected to be an open-drain or open-source output. |
| | | PWM1 | PWM Output 1 Inverted | Output | This pin is used by Timer 3 for Negative PWM 1. This signal is multiplexed with PA5. |
| | | TOUT1 | Timer Out | Output | This pin is used by Timer 1 timer-out signal. This signal is multiplexed with PA5. |

Note: *PHY represents the physical layer of the OSI model.



Table 2. Pin Identification on the eZ80F91 Device (Continued)

| LQFP Pin # | BGA Pin# | Symbol | Function | Signal Direction | Description |
|------------|----------|-----------------|-----------------------|------------------|--|
| 120 | F7 | PA6 | GPIO Port A | Bidirectional | This pin can be used for general-purpose I/O. It can be individually programmed as input or output and can also be used individually as an interrupt input. Each Port A pin, when programmed as output, can be selected to be an open-drain or open-source output. |
| | | PWM2 | PWM Output 2 Inverted | Output | This pin is used by Timer 3 for Negative PWM 2. This signal is multiplexed with PA6. |
| | | EC1 | Event Counter | Input | Event Counter Signal to Timer 2. This signal is multiplexed with PA6. |
| 121 | A8 | PA7 | GPIO Port A | Bidirectional | This pin can be used for general-purpose I/O. It can be individually programmed as input or output and can also be used individually as an interrupt input. Each Port A pin, when programmed as output, can be selected to be an open-drain or open-source output. |
| | | PWM3 | PWM Output 3 Inverted | Output | This pin is used by Timer 3 for Negative PWM 3. This signal is multiplexed with PA7. |
| 122 | B8 | V _{DD} | Power Supply | | Power Supply. |
| 123 | C8 | V _{SS} | Ground | | Ground. |
| 124 | D8 | CRS | MII Carrier Sense | Input | This pin is used by the Ethernet MAC for the MII Interface to the PHY*. Carrier Sense is an asynchronous signal. |
| 125 | A7 | COL | MII Collision Detect | Input | This pin is used by the Ethernet MAC for the MII Interface to the PHY. Collision Detect is an asynchronous signal. |

Note: *PHY represents the physical layer of the OSI model.



Table 2. Pin Identification on the eZ80F91 Device (Continued)

| LQFP Pin # | BGA Pin# | Symbol | Function | Signal Direction | Description |
|------------|----------|-----------------|---------------------|------------------|--|
| 126 | B7 | TxD3 | MII Transmit Data | Output | This pin is used by the Ethernet MAC for the MII Interface to the PHY. Transmit Data is synchronous to the rising-edge of Tx_CLK. |
| 127 | C7 | TxD2 | MII Transmit Data | Output | This pin is used by the Ethernet MAC for the MII Interface to the PHY. Transmit Data is synchronous to the rising-edge of Tx_CLK. |
| 128 | D7 | TxD1 | MII Transmit Data | Output | This pin is used by the Ethernet MAC for the MII Interface to the PHY. Transmit Data is synchronous to the rising-edge of Tx_CLK. |
| 129 | A6 | TxD0 | MII Transmit Data | Output | This pin is used by the Ethernet MAC for the MII Interface to the PHY. Transmit Data is synchronous to the rising-edge of Tx_CLK. |
| 130 | B6 | Tx_EN | MII Transmit Enable | Output | This pin is used by the Ethernet MAC for the MII Interface to the PHY. Transmit Enable is synchronous to the rising-edge of Tx_CLK. |
| 131 | C6 | Tx_CLK | MII Transmit Clock | Input | This pin is used by the Ethernet MAC for the MII Interface to the PHY. Transmit Clock is the Nibble or Symbol Clock provided by the MII PHY Interface. |
| 132 | E7 | Tx_ER | MII Transmit Error | Output | This pin is used by the Ethernet MAC for the MII Interface to the PHY. Transmit Error is synchronous to the rising-edge of Tx_CLK. |
| 133 | A5 | V _{DD} | Power Supply | | Power Supply. |
| 134 | B5 | V _{SS} | Ground | | Ground. |

Note: *PHY represents the physical layer of the OSI model.



Table 2. Pin Identification on the eZ80F91 Device (Continued)

| LQFP Pin # | BGA Pin# | Symbol | Function | Signal Direction | Description |
|------------|----------|--------|------------------------|------------------|--|
| 135 | D6 | Rx_ER | MII Receive Error | Input | This pin is used by the Ethernet MAC for the MII Interface to the PHY. Receive Error is provided by the MII PHY Interface synchronous to the rising-edge of Rx_CLK. |
| 136 | C5 | Rx_CLK | MII Receive Clock | Input | This pin is used by the Ethernet MAC for the MII Interface to the PHY. Receive Clock is the Nibble or Symbol Clock provided by the MII PHY Interface. |
| 137 | A4 | Rx_DV | MII Receive Data Valid | Input | This pin is used by the Ethernet MAC for the MII Interface to the PHY. Receive Data Valid is provided by the MII PHY Interface synchronous to the rising-edge of Rx_CLK. |
| 138 | E6 | RxD0 | MII Receive Data | Input | This pin is used by the Ethernet MAC for the MII Interface to the PHY. Receive Data is provided by the MII PHY Interface synchronous to the rising-edge of Rx_CLK. |
| 139 | B4 | RxD1 | MII Receive Data | Input | This pin is used by the Ethernet MAC for the MII Interface to the PHY. Receive Data is provided by the MII PHY Interface synchronous to the rising-edge of Rx_CLK. |
| 140 | D5 | RxD2 | MII Receive Data | Input | This pin is used by the Ethernet MAC for the MII Interface to the PHY. Receive Data is provided by the MII PHY Interface synchronous to the rising-edge of Rx_CLK. |

Note: *PHY represents the physical layer of the OSI model.



Table 2. Pin Identification on the eZ80F91 Device (Continued)

| LQFP Pin # | BGA Pin# | Symbol | Function | Signal Direction | Description |
|------------|----------|------------------------|---------------------------|-----------------------------------|--|
| 141 | C4 | RxD3 | MII Receive Data | Input | This pin is used by the Ethernet MAC for the MII Interface to the PHY. Receive Data is provided by the MII PHY Interface synchronous to the rising-edge of Rx_CLK. |
| 142 | A3 | MDC | MII Management Data Clock | Output | This pin is used by the Ethernet MAC for the MII Management Interface to the PHY. The Ethernet MAC provides the MII Management Data Clock to the MII PHY Interface. |
| 143 | B3 | MDIO | MII Management Data | Bidirectional | This pin is used by the Ethernet MAC for the MII Management Interface to the PHY. The Ethernet MAC sends and receives the MII Management Data to and from the MII PHY Interface. |
| 144 | A2 | $\overline{\text{WP}}$ | Write Protect | Schmitt-trigger input, Active Low | The Write Protect input is used by the Flash Controller to protect the Boot Block from Write and ERASE operations. |

Note: *PHY represents the physical layer of the OSI model.

System Clock Source Options

System Clock. The eZ80F91 device's internal clock, SCLK, is responsible for clocking all internal logic. The SCLK source can be an external crystal oscillator, an internal PLL, or an internal 32kHz RTC oscillator. The SCLK source is selected by PLL Control Register 0. RESET default is provided by the external crystal oscillator. Refer to the CLK_MUX values in the PLL Control Register 0, [Table 207](#) on page 325 for details.

PHI. PHI is a device output driven by SCLK that can be used for system synchronization to the eZ80F91 device. PHI is used as the reference clock for all [AC Characteristics](#).

External Crystal Oscillator. An externally-driven oscillator that can operate in two modes. In one mode, the X_{IN} pin can be driven by a *can* oscillator from DC up to

50MHz while the X_{OUT} pin is unconnected. In the other mode, the X_{IN} and X_{OUT} pins can be driven by a crystal circuit.

Crystals recommended by ZiLOG are defined to be a 50MHz–3 overtone circuit or 1–10MHz range fundamental for PLL operation. For details, refer to the [On-Chip Oscillators](#) section on page 342.

Real Time Clock. An internal 32KHz real-time clock crystal oscillator driven by either the on-chip 32768Hz crystal oscillator or a 50/60Hz power-line frequency input. While intended for timekeeping, the RTC 32KHz oscillator can be selected as an SCLK. $RTC_{V_{DD}}$ and $RTC_{V_{SS}}$ provide an isolated power supply to ensure RTC operation in the event of loss of line power when a battery is provided. For details, refer to the [On-Chip Oscillators](#) section on page 342.

PLL Clock. The eZ80F91 internal PLL driven by external crystals or *can* oscillators in the 1MHz to 10MHz range to generate an SCLK up to 50MHz. For details, refer to the [Phase-Locked Loop](#) section on page 320.

SCLK Source Selection Example

If an application must run the eZ80F91 device at 40MHz, the following solutions are possible:

- Use a 40MHz–3rd overtone crystal (not recommended due to its weak fundamental rating)
- Use a 40MHz *can* oscillator (expensive)
- Use an 8MHz fundamental two-pin crystal and program the internal PLL with a multiplier of five to achieve 40MHz (inexpensive).



Register Map

All on-chip peripheral registers are accessed in the I/O address space. All I/O operations employ 16-bit addresses. The upper byte of the 24-bit address bus is undefined during all I/O operations (ADDR[23:16] = UU). All I/O operations using 16-bit addresses within the range 0000h–00FFh are routed to the on-chip peripherals. External I/O Chip Selects are not generated if the address space programmed for the I/O Chip Selects overlaps the 0000h–00FFh address range.

Registers at unused addresses within the 0000h–00FFh range assigned to on-chip peripherals are not implemented. Read access to such addresses returns unpredictable values and Write access produces no effect. Table 3 diagrams the register map for the eZ80F91 device.

Table 3. Register Map

| Address (hex) | Mnemonic | Name | Reset (hex) | CPU Access | Page # |
|---------------------------|------------|------------------------------------|-------------|------------|---------------------|
| Product ID | | | | | |
| 0000 | ZDI_ID_L | eZ80 Product ID Low Byte Register | 08 | R | 305 |
| 0001 | ZDI_ID_H | eZ80 Product ID High Byte Register | 00 | R | 306 |
| 0002 | ZDI_ID_REV | eZ80 Product ID Revision Register | XX | R | 306 |
| Interrupt Priority | | | | | |
| 0010 | INT_P0 | Interrupt Priority Register—Byte 0 | 00 | R/W | 69 |
| 0011 | INT_P1 | Interrupt Priority Register—Byte 1 | 00 | R/W | 69 |
| 0012 | INT_P2 | Interrupt Priority Register—Byte 2 | 00 | R/W | 69 |
| 0013 | INT_P3 | Interrupt Priority Register—Byte 3 | 00 | R/W | 69 |
| 0014 | INT_P4 | Interrupt Priority Register—Byte 4 | 00 | R/W | 69 |
| 0015 | INT_P5 | Interrupt Priority Register—Byte 5 | 00 | R/W | 69 |

Notes:

1. After an external pin reset, the Watch-Dog Timer Control register is reset to 00h. After a Watch-Dog Timer time-out reset, the Watch-Dog Timer Control register is reset to 20h.
2. When the CPU reads this register, the current sampled value of the port is read.
3. Read Only if RTC is locked; Read/Write if RTC is unlocked.
4. After an external pin reset or a Watch-Dog Timer reset, the RTC Control register is reset to x0xxxx00b. After an RTC Alarm sleep-mode recovery reset, the RTC Control register is reset to x0xxxx10b.
5. Read Only if Flash Memory is locked. Read/Write if Flash Memory is unlocked.



Table 3. Register Map (Continued)

| Address (hex) | Mnemonic | Name | Reset (hex) | CPU Access | Page # |
|---|-------------|---|----------------|---------------|---------------------|
| Ethernet Media Access Controller | | | | | |
| 0020 | EMAC_TEST | EMAC Test Register | 00 | R/W | 249 |
| 0021 | EMAC_CFG1 | EMAC Configuration Register | 00 | R/W | 251 |
| 0022 | EMAC_CFG2 | EMAC Configuration Register | 37 | R/W | 253 |
| 0023 | EMAC_CFG3 | EMAC Configuration Register | 0F | R/W | 254 |
| 0024 | EMAC_CFG4 | EMAC Configuration Register | 00 | R/W | 255 |
| 0025 | EMAC_STAD_0 | EMAC Station Address—Byte 0 | 00 | R/W | 256 |
| 0026 | EMAC_STAD_1 | EMAC Station Address—Byte 1 | 00 | R/W | 256 |
| 0027 | EMAC_STAD_2 | EMAC Station Address—Byte 2 | 00 | R/W | 256 |
| 0028 | EMAC_STAD_3 | EMAC Station Address—Byte 3 | 00 | R/W | 256 |
| 0029 | EMAC_STAD_4 | EMAC Station Address—Byte 4 | 00 | R/W | 256 |
| 002A | EMAC_STAD_5 | EMAC Station Address—Byte 5 | 00 | R/W | 256 |
| 002B | EMAC_TPTV_L | EMAC Transmit Pause Timer Value— Low Byte | 00 | R/W | 257 |
| 002C | EMAC_TPTV_H | EMAC Transmit Pause Timer Value— High Byte | 00 | R/W | 257 |
| 002D | EMAC_IPGT | EMAC Inter-Packet Gap | 15 | R/W | 258 |
| 002E | EMAC_IPGR1 | EMAC Non-Back-Back IPG | 0C | R/W | 260 |
| 002F | EMAC_IPGR2 | EMAC Non-Back-Back IPG | 12 | R/W | 261 |
| 0030 | EMAC_MAXF_L | EMAC Maximum Frame Length—Low Byte | 00 | R/W | 261 |
| 0031 | EMAC_MAXF_H | EMAC Maximum Frame Length—High Byte | 06 | R/W | 262 |
| 0032 | EMAC_AFR | EMAC Address Filter Register | 00 | R/W | 263 |
| 0033 | EMAC_HTBL_0 | EMAC Hash Table—Byte 0 | 00 | R/W | 264 |

Notes:

1. After an external pin reset, the Watch-Dog Timer Control register is reset to 00h. After a Watch-Dog Timer time-out reset, the Watch-Dog Timer Control register is reset to 20h.
2. When the CPU reads this register, the current sampled value of the port is read.
3. Read Only if RTC is locked; Read/Write if RTC is unlocked.
4. After an external pin reset or a Watch-Dog Timer reset, the RTC Control register is reset to x0xxxx00b. After an RTC Alarm sleep-mode recovery reset, the RTC Control register is reset to x0xxxx10b.
5. Read Only if Flash Memory is locked. Read/Write if Flash Memory is unlocked.

Table 3. Register Map (Continued)

| Address (hex) | Mnemonic | Name | Reset (hex) | CPU Access | Page # |
|--|-------------|---|----------------|---------------|---------------------|
| Ethernet Media Access Controller, continued | | | | | |
| 0034 | EMAC_HTBL_1 | EMAC Hash Table—Byte 1 | 00 | R/W | 264 |
| 0035 | EMAC_HTBL_2 | EMAC Hash Table—Byte 2 | 00 | R/W | 264 |
| 0036 | EMAC_HTBL_3 | EMAC Hash Table—Byte 3 | 00 | R/W | 264 |
| 0037 | EMAC_HTBL_4 | EMAC Hash Table—Byte 4 | 00 | R/W | 264 |
| 0038 | EMAC_HTBL_5 | EMAC Hash Table—Byte 5 | 00 | R/W | 264 |
| 0039 | EMAC_HTBL_6 | EMAC Hash Table—Byte 6 | 00 | R/W | 264 |
| 003A | EMAC_HTBL_7 | EMAC Hash Table—Byte 7 | 00 | R/W | 264 |
| 003B | EMAC_MIIMGT | EMAC MII Management Register | 00 | R/W | 265 |
| 003C | EMAC_CTLD_L | EMAC PHY Configuration Data—Low Byte | 00 | R/W | 266 |
| 003D | EMAC_CTLD_H | EMAC PHY Configuration Data—High Byte | 00 | R/W | 267 |
| 003E | EMAC_RGAD | EMAC PHY Register Address Register | 00 | R/W | 267 |
| 003F | EMAC_FIAD | EMAC PHY Unit Select Address Register | 00 | R/W | 268 |
| 0040 | EMAC_PTMR | EMAC Transmit Polling Timer Register | 00 | R/W | 268 |
| 0041 | EMAC_RST | EMAC Reset Control Register | 00 | R/W | 269 |
| 0042 | EMAC_TLBP_L | EMAC Transmit Lower Boundary Pointer—Low Byte | 00 | R/W | 270 |
| 0043 | EMAC_TLBP_H | EMAC Transmit Lower Boundary Pointer—High Byte | 00 | R/W | 270 |
| 0044 | EMAC_BP_L | EMAC Boundary Pointer—Low Byte | 00 | R/W | 271 |
| 0045 | EMAC_BP_H | EMAC Boundary Pointer—High Byte | C0 | R/W | 271 |
| 0046 | EMAC_BP_U | EMAC Boundary Pointer—Upper Byte | FF | R/W | 272 |

Notes:

1. After an external pin reset, the Watch-Dog Timer Control register is reset to 00h. After a Watch-Dog Timer time-out reset, the Watch-Dog Timer Control register is reset to 20h.
2. When the CPU reads this register, the current sampled value of the port is read.
3. Read Only if RTC is locked; Read/Write if RTC is unlocked.
4. After an external pin reset or a Watch-Dog Timer reset, the RTC Control register is reset to x0xxxx00b. After an RTC Alarm sleep-mode recovery reset, the RTC Control register is reset to x0xxxx10b.
5. Read Only if Flash Memory is locked. Read/Write if Flash Memory is unlocked.



Table 3. Register Map (Continued)

| Address (hex) | Mnemonic | Name | Reset (hex) | CPU Access | Page # |
|--|----------------|--|----------------|---------------|---------------------|
| Ethernet Media Access Controller, continued | | | | | |
| 0047 | EMAC_RHBP_L | EMAC Receive High Boundary Pointer—Low Byte | 00 | R/W | 272 |
| 0048 | EMAC_RHBP_H | EMAC Receive High Boundary Pointer—High Byte | 00 | R/W | 273 |
| 0049 | EMAC_RRP_L | EMAC Receive Read Pointer—Low Byte | 00 | R/W | 273 |
| 004A | EMAC_RRP_H | EMAC Receive Read Pointer—High Byte | 00 | R/W | 274 |
| 004B | EMAC_BUFSZ | EMAC Buffer Size Register | 00 | R/W | 274 |
| 004C | EMAC_IEN | EMAC Interrupt Enable Register | 00 | R/W | 275 |
| 004D | EMAC_ISTAT | EMAC Interrupt Status Register | 00 | R/W | 277 |
| 004E | EMAC_PRSD_L | EMAC PHY Read Status Data—Low Byte | 00 | R/W | 278 |
| 004F | EMAC_PRSD_H | EMAC PHY Read Status Data—High Byte | 00 | R/W | 279 |
| 0050 | EMAC_MIISTAT | EMAC MII Status Register | 00 | R/W | 279 |
| 0051 | EMAC_RWP_L | EMAC Receive Write Pointer—Low Byte | 00 | R/W | 280 |
| 0052 | EMAC_RWP_H | EMAC Receive Write Pointer—High Byte | 00 | R/W | 281 |
| 0053 | EMAC_TRP_L | EMAC Transmit Read Pointer—Low Byte | 00 | R/W | 281 |
| 0054 | EMAC_TRP_H | EMAC Transmit Read Pointer—High Byte | 00 | R/W | 282 |
| 0055 | EMAC_BLKSLFT_L | EMAC Receive Blocks Left Register—Low Byte | 00 | R/W | 282 |

Notes:

1. After an external pin reset, the Watch-Dog Timer Control register is reset to 00h. After a Watch-Dog Timer time-out reset, the Watch-Dog Timer Control register is reset to 20h.
2. When the CPU reads this register, the current sampled value of the port is read.
3. Read Only if RTC is locked; Read/Write if RTC is unlocked.
4. After an external pin reset or a Watch-Dog Timer reset, the RTC Control register is reset to x0xxxx00b. After an RTC Alarm sleep-mode recovery reset, the RTC Control register is reset to x0xxxx10b.
5. Read Only if Flash Memory is locked. Read/Write if Flash Memory is unlocked.



Table 3. Register Map (Continued)

| Address (hex) | Mnemonic | Name | Reset (hex) | CPU Access | Page # |
|--|----------------|---|----------------|---------------|---------------------|
| Ethernet Media Access Controller, continued | | | | | |
| 0056 | EMAC_BLKSLFT_H | EMAC Receive Blocks Left Register— High Byte | 00 | R/W | 283 |
| 0057 | EMAC_FDATA_L | EMAC FIFO Data—Low Byte | 0X | R/W | 284 |
| 0058 | EMAC_FDATA_H | EMAC FIFO Data—High Byte | XX | R/W | 284 |
| 0059 | EMAC_FFLAGS | EMAC FIFO Flags Register | 33 | R/W | 285 |
| PLL | | | | | |
| 005C | PLL_DIV_L | PLL Divider Register—Low Byte | 00 | W | 324 |
| 005D | PLL_DIV_H | PLL Divider Register—High Byte | 00 | W | 324 |
| 005E | PLL_CTL0 | PLL Control Register 0 | 00 | R/W | 325 |
| 005F | PLL_CTL1 | PLL Control Register 1 | 00 | R/W | 326 |
| Timers and PWM | | | | | |
| 0060 | TMR0_CTL | Timer 0 Control Register | 00 | R/W | 138 |
| 0061 | TMR0_IER | Timer 0 Interrupt Enable Register | 00 | R/W | 139 |
| 0062 | TMR0_IIR | Timer 0 Interrupt Identification Register | 00 | R/W | 141 |
| 0063 | TMR0_DR_L | Timer 0 Data Register—Low Byte | XX | R | 142 |
| | TMR0_RR_L | Timer 0 Reload Register—Low Byte | XX | W | 143 |
| 0064 | TMR0_DR_H | Timer 0 Data Register—High Byte | XX | R | 143 |
| | TMR0_RR_H | Timer 0 Reload Register—High Byte | XX | W | 144 |
| 0065 | TMR1_CTL | Timer 1 Control Register | 00 | R/W | 138 |
| 0066 | TMR1_IER | Timer 1 Interrupt Enable Register | 00 | R/W | 139 |
| 0067 | TMR1_IIR | Timer 1 Interrupt Identification Register | 00 | R/W | 141 |
| 0068 | TMR1_DR_L | Timer 1 Data Register—Low Byte | XX | R | 142 |
| | TMR1_RR_L | Timer 1 Reload Register—Low Byte | XX | W | 143 |

Notes:

1. After an external pin reset, the Watch-Dog Timer Control register is reset to 00h. After a Watch-Dog Timer time-out reset, the Watch-Dog Timer Control register is reset to 20h.
2. When the CPU reads this register, the current sampled value of the port is read.
3. Read Only if RTC is locked; Read/Write if RTC is unlocked.
4. After an external pin reset or a Watch-Dog Timer reset, the RTC Control register is reset to x0xxxx00b. After an RTC Alarm sleep-mode recovery reset, the RTC Control register is reset to x0xxxx10b.
5. Read Only if Flash Memory is locked. Read/Write if Flash Memory is unlocked.

Table 3. Register Map (Continued)

| Address (hex) | Mnemonic | Name | Reset (hex) | CPU Access | Page # |
|----------------------------------|--------------|--|----------------|---------------|---------------------|
| Timers and PWM, continued | | | | | |
| 0069 | TMR1_DR_H | Timer 1 Data Register—High Byte | XX | R | 143 |
| | TMR1_RR_H | Timer 1 Reload Register—High Byte | XX | W | 144 |
| 006A | TMR1_CAP_CTL | Timer 1 Input Capture Control Register | XX | R/W | 144 |
| 006B | TMR1_CAPA_L | Timer 1 Capture Value A Register— Low Byte | XX | R/W | 145 |
| 006C | TMR1_CAPA_H | Timer 1 Capture Value A Register— High Byte | XX | R/W | 146 |
| 006D | TMR1_CAPB_L | Timer 1 Capture Value B Register— Low Byte | XX | R/W | 146 |
| 006E | TMR1_CAPB_H | Timer 1 Capture Value B Register— High Byte | XX | R/W | 147 |
| 006F | TMR2_CTL | Timer 2 Control Register | 00 | R/W | 138 |
| 0070 | TMR2_IER | Timer 2 Interrupt Enable Register | 00 | R/W | 139 |
| 0071 | TMR2_IIR | Timer 2 Interrupt Identification Register | 00 | R/W | 141 |
| 0072 | TMR2_DR_L | Timer 2 Data Register—Low Byte | XX | R | 142 |
| | TMR2_RR_L | Timer 2 Reload Register—Low Byte | XX | W | 143 |
| 0073 | TMR2_DR_H | Timer 2 Data Register—High Byte | XX | R | 143 |
| | TMR2_RR_H | Timer 2 Reload Register—High Byte | XX | W | 144 |
| 0074 | TMR3_CTL | Timer 3 Control Register | 00 | R/W | 138 |
| 0075 | TMR3_IER | Timer 3 Interrupt Enable Register | 00 | R/W | 139 |
| 0076 | TMR3_IIR | Timer 3 Interrupt Identification Register | 00 | R/W | 141 |
| 0077 | TMR3_DR_L | Timer 3 Data Register—Low Byte | XX | R | 142 |
| | TMR3_RR_L | Timer 3 Reload Register—Low Byte | XX | W | 143 |

Notes:

1. After an external pin reset, the Watch-Dog Timer Control register is reset to 00h. After a Watch-Dog Timer time-out reset, the Watch-Dog Timer Control register is reset to 20h.
2. When the CPU reads this register, the current sampled value of the port is read.
3. Read Only if RTC is locked; Read/Write if RTC is unlocked.
4. After an external pin reset or a Watch-Dog Timer reset, the RTC Control register is reset to x0xxxx00b. After an RTC Alarm sleep-mode recovery reset, the RTC Control register is reset to x0xxxx10b.
5. Read Only if Flash Memory is locked. Read/Write if Flash Memory is unlocked.



Table 3. Register Map (Continued)

| Address (hex) | Mnemonic | Name | Reset (hex) | CPU Access | Page # |
|----------------------------------|--------------|--|----------------|---------------|---------------------|
| Timers and PWM, continued | | | | | |
| 0078 | TMR3_DR_H | Timer 3 Data Register—High Byte | XX | R | 143 |
| | TMR3_RR_H | Timer 3 Reload Register—High Byte | XX | W | 144 |
| 0079 | PWM_CTL1 | PWM Control Register 1 | 00 | R/W | 158 |
| 007A | PWM_CTL2 | PWM Control Register 2 | 00 | R/W | 159 |
| 007B | PWM_CTL3 | PWM Control Register 3 | 00 | R/W | 161 |
| | TMR3_CAP_CTL | Timer 3 Input Capture Control Register | 00 | R/W | 144 |
| 007C | PWM0R_L | PWM 0 Rising-Edge Register—Low Byte | XX | R/W | 162 |
| | TMR3_CAPA_L | Timer 3 Capture Value A Register—Low Byte | XX | R/W | 145 |
| 007D | PWM0R_H | PWM 0 Rising-Edge Register—High Byte | XX | R/W | 163 |
| | TMR3_CAPA_H | Timer 3 Capture Value A Register—High Byte | XX | R/W | 146 |
| 007E | PWM1R_L | PWM 1 Rising-Edge Register—Low Byte | XX | R/W | 162 |
| | TMR3_CAPB_L | Timer 3 Capture Value B Register—Low Byte | XX | R/W | 146 |
| 007F | PWM1R_H | PWM 1 Rising-Edge Register—High Byte | XX | R/W | 163 |
| | TMR3_CAPB_H | Timer 3 Capture Value B Register—High Byte | XX | R/W | 147 |
| 0080 | PWM2R_L | PWM 2 Rising-Edge Register—Low Byte | XX | R/W | 162 |
| | TMR3_OC_CTL1 | Timer 3 Output Compare Control Register 1 | 00 | R/W | 138 |

Notes:

1. After an external pin reset, the Watch-Dog Timer Control register is reset to 00h. After a Watch-Dog Timer time-out reset, the Watch-Dog Timer Control register is reset to 20h.
2. When the CPU reads this register, the current sampled value of the port is read.
3. Read Only if RTC is locked; Read/Write if RTC is unlocked.
4. After an external pin reset or a Watch-Dog Timer reset, the RTC Control register is reset to x0xxxx00b. After an RTC Alarm sleep-mode recovery reset, the RTC Control register is reset to x0xxxx10b.
5. Read Only if Flash Memory is locked. Read/Write if Flash Memory is unlocked.



Table 3. Register Map (Continued)

| Address (hex) | Mnemonic | Name | Reset (hex) | CPU Access | Page # |
|----------------------------------|--------------|---|----------------|---------------|---------------------|
| Timers and PWM, continued | | | | | |
| 0081 | PWM2R_H | PWM 2 Rising-Edge Register—High Byte | XX | R/W | 163 |
| | TMR3_OC_CTL2 | Timer 3 Output Compare Control Register 2 | 00 | R/W | 138 |
| 0082 | PWM3R_L | PWM 3 Rising-Edge Register—Low Byte | XX | R/W | 162 |
| | TMR3_OC0_L | Timer 3 Output Compare 0 Value Register—Low Byte | XX | R/W | 149 |
| 0083 | PWM3R_H | PWM 3 Rising-Edge Register—High Byte | XX | R/W | 163 |
| | TMR3_OC0_H | Timer 3 Output Compare 0 Value Register—High Byte | XX | R/W | 150 |
| 0084 | PWM0F_L | PWM 0 Falling-Edge Register—Low Byte | XX | R/W | 164 |
| | TMR3_OC1_L | Timer 3 Output Compare 1 Value Register—Low Byte | XX | R/W | 149 |
| 0085 | PWM0F_H | PWM 0 Falling-Edge Register—High Byte | XX | R/W | 165 |
| | TMR3_OC1_H | Timer 3 Output Compare 1 Value Register—High Byte | XX | R/W | 150 |
| 0086 | PWM1F_L | PWM 1 Falling-Edge Register—Low Byte | XX | R/W | 164 |
| | TMR3_OC2_L | Timer 3 Output Compare 2 Value Register—Low Byte | XX | R/W | 149 |

Notes:

1. After an external pin reset, the Watch-Dog Timer Control register is reset to 00h. After a Watch-Dog Timer time-out reset, the Watch-Dog Timer Control register is reset to 20h.
2. When the CPU reads this register, the current sampled value of the port is read.
3. Read Only if RTC is locked; Read/Write if RTC is unlocked.
4. After an external pin reset or a Watch-Dog Timer reset, the RTC Control register is reset to x0xxxx00b. After an RTC Alarm sleep-mode recovery reset, the RTC Control register is reset to x0xxxx10b.
5. Read Only if Flash Memory is locked. Read/Write if Flash Memory is unlocked.



Table 3. Register Map (Continued)

| Address (hex) | Mnemonic | Name | Reset (hex) | CPU Access | Page # |
|---|------------|---|--------------------|------------------|---------------------|
| Timers and PWM, continued | | | | | |
| 0087 | PWM1F_H | PWM 1 Falling-Edge Register—High Byte | XX | R/W | 165 |
| | TMR3_OC2_H | Timer 3 Output Compare 2 Value Register—High Byte | XX | R/W | 150 |
| 0088 | PWM2F_L | PWM 2 Falling-Edge Register—Low Byte | XX | R/W | 164 |
| | TMR3_OC3_L | Timer 3 Output Compare 3 Value Register—Low Byte | XX | R/W | 149 |
| 0089 | PWM2F_H | PWM 2 Falling-Edge Register—High Byte | XX | R/W | 165 |
| | TMR3_OC3_H | Timer 3 Output Compare 3 Value Register—High Byte | XX | R/W | 150 |
| 008A | PWM3F_L | PWM 3 Falling-Edge Register—Low Byte | XX | R/W | 164 |
| 008B | PWM3F_H | PWM 3 Falling-Edge Register—High Byte | XX | R/W | 165 |
| Watch-Dog Timer | | | | | |
| 0093 | WDT_CTL | Watch-Dog Timer Control Register | 00/20 ¹ | R/W | 124 |
| 0094 | WDT_RR | Watch-Dog Timer Reset Register | XX | W | 126 |
| General-Purpose Input/Output Ports | | | | | |
| 0096 | PA_DR | Port A Data Register | XX | R/W ² | 63 |
| 0097 | PA_DDR | Port A Data Direction Register | FF | R/W | 63 |
| 0098 | PA_ALT1 | Port A Alternate Register 1 | 00 | R/W | 63 |
| 0099 | PA_ALT2 | Port A Alternate Register 2 | 00 | R/W | 64 |
| 009A | PB_DR | Port B Data Register | XX | R/W ² | 63 |

Notes:

1. After an external pin reset, the Watch-Dog Timer Control register is reset to 00h. After a Watch-Dog Timer time-out reset, the Watch-Dog Timer Control register is reset to 20h.
2. When the CPU reads this register, the current sampled value of the port is read.
3. Read Only if RTC is locked; Read/Write if RTC is unlocked.
4. After an external pin reset or a Watch-Dog Timer reset, the RTC Control register is reset to x0xxxx00b. After a an RTC Alarm sleep-mode recovery reset, the RTC Control register is reset to x0xxxx10b.
5. Read Only if Flash Memory is locked. Read/Write if Flash Memory is unlocked.



Table 3. Register Map (Continued)

| Address (hex) | Mnemonic | Name | Reset (hex) | CPU Access | Page # |
|--|----------|------------------------------------|----------------|------------------|--------------------|
| General-Purpose Input/Output Ports, continued | | | | | |
| 009B | PB_DDR | Port B Data Direction Register | FF | R/W | 63 |
| 009C | PB_ALT1 | Port B Alternate Register 1 | 00 | R/W | 63 |
| 009D | PB_ALT2 | Port B Alternate Register 2 | 00 | R/W | 64 |
| 009E | PC_DR | Port C Data Register | XX | R/W ² | 63 |
| 009F | PC_DDR | Port C Data Direction Register | FF | R/W | 63 |
| 00A0 | PC_ALT1 | Port C Alternate Register 1 | 00 | R/W | 63 |
| 00A1 | PC_ALT2 | Port C Alternate Register 2 | 00 | R/W | 64 |
| 00A2 | PD_DR | Port D Data Register | XX | R/W ² | 63 |
| 00A3 | PD_DDR | Port D Data Direction Register | FF | R/W | 63 |
| 00A4 | PD_ALT1 | Port D Alternate Register 1 | 00 | R/W | 63 |
| 00A5 | PD_ALT2 | Port D Alternate Register 2 | 00 | R/W | 64 |
| Chip Select/Wait State Generator | | | | | |
| 00A8 | CS0_LBR | Chip Select 0 Lower Bound Register | 00 | R/W | 93 |
| 00A9 | CS0_UBR | Chip Select 0 Upper Bound Register | FF | R/W | 94 |
| 00AA | CS0_CTL | Chip Select 0 Control Register | E8 | R/W | 95 |
| 00AB | CS1_LBR | Chip Select 1 Lower Bound Register | 00 | R/W | 93 |
| 00AC | CS1_UBR | Chip Select 1 Upper Bound Register | 00 | R/W | 94 |
| 00AD | CS1_CTL | Chip Select 1 Control Register | 00 | R/W | 95 |
| 00AE | CS2_LBR | Chip Select 2 Lower Bound Register | 00 | R/W | 93 |
| 00AF | CS2_UBR | Chip Select 2 Upper Bound Register | 00 | R/W | 94 |
| 00B0 | CS2_CTL | Chip Select 2 Control Register | 00 | R/W | 95 |
| 00B1 | CS3_LBR | Chip Select 3 Lower Bound Register | 00 | R/W | 93 |

Notes:

1. After an external pin reset, the Watch-Dog Timer Control register is reset to 00h. After a Watch-Dog Timer time-out reset, the Watch-Dog Timer Control register is reset to 20h.
2. When the CPU reads this register, the current sampled value of the port is read.
3. Read Only if RTC is locked; Read/Write if RTC is unlocked.
4. After an external pin reset or a Watch-Dog Timer reset, the RTC Control register is reset to x0xxxx00b. After an RTC Alarm sleep-mode recovery reset, the RTC Control register is reset to x0xxxx10b.
5. Read Only if Flash Memory is locked. Read/Write if Flash Memory is unlocked.



Table 3. Register Map (Continued)

| Address (hex) | Mnemonic | Name | Reset (hex) | CPU Access | Page # |
|--|-------------|---|----------------|---------------|---------------------|
| Chip Select/Wait State Generator, continued | | | | | |
| 00B2 | CS3_UBR | Chip Select 3 Upper Bound Register | 00 | R/W | 94 |
| 00B3 | CS3_CTL | Chip Select 3 Control Register | 00 | R/W | 95 |
| Random Access Memory Control | | | | | |
| 00B4 | RAM_CTL | RAM Control Register | 80 | R/W | 102 |
| 00B5 | RAM_ADDR_U | RAM Address Upper Byte Register | FF | R/W | 103 |
| 00B6 | MBIST_GPR | General Purpose RAM MBIST Control | 00 | R/W | 104 |
| 00B7 | MBIST_EMR | Ethernet MAC RAM MBIST Control | 00 | R/W | 104 |
| Serial Peripheral Interface | | | | | |
| 00B8 | SPI_BRG_L | SPI Baud Rate Generator Register— Low Byte | 02 | R/W | 215 |
| 00B9 | SPI_BRG_H | SPI Baud Rate Generator Register— High Byte | 00 | R/W | 215 |
| 00BA | SPI_CTL | SPI Control Register | 04 | R/W | 216 |
| 00BB | SPI_SR | SPI Status Register | 00 | R | 217 |
| 00BC | SPI_TSR | SPI Transmit Shift Register | XX | W | 218 |
| | SPI_RBR | SPI Receive Buffer Register | XX | R | 218 |
| Infrared Encoder/Decoder | | | | | |
| 00BF | IR_CTL | Infrared Encoder/Decoder Control | 00 | R/W | 207 |
| Universal Asynchronous Receiver/Transmitter 0 (UART0) | | | | | |
| 00C0 | UART0_RBR | UART 0 Receive Buffer Register | XX | R | 192 |
| | UART0_THR | UART 0 Transmit Holding Register | XX | W | 191 |
| | UART0_BRG_L | UART 0 Baud Rate Generator Register—Low Byte | 02 | R/W | 190 |

Notes:

1. After an external pin reset, the Watch-Dog Timer Control register is reset to 00h. After a Watch-Dog Timer time-out reset, the Watch-Dog Timer Control register is reset to 20h.
2. When the CPU reads this register, the current sampled value of the port is read.
3. Read Only if RTC is locked; Read/Write if RTC is unlocked.
4. After an external pin reset or a Watch-Dog Timer reset, the RTC Control register is reset to x0xxxx00b. After an RTC Alarm sleep-mode recovery reset, the RTC Control register is reset to x0xxxx10b.
5. Read Only if Flash Memory is locked. Read/Write if Flash Memory is unlocked.



Table 3. Register Map (Continued)

| Address (hex) | Mnemonic | Name | Reset (hex) | CPU Access | Page # |
|---|-------------|--|-------------|------------|---------------------|
| Universal Asynchronous Receiver/Transmitter 0 (UART0), continued | | | | | |
| 00C1 | UART0_IER | UART 0 Interrupt Enable Register | 00 | R/W | 192 |
| | UART0_BRG_H | UART 0 Baud Rate Generator Register—High Byte | 00 | R/W | 190 |
| 00C2 | UART0_IIR | UART 0 Interrupt Identification Register | 01 | R | 193 |
| | UART0_FCTL | UART 0 FIFO Control Register | 00 | W | 195 |
| 00C3 | UART0_LCTL | UART 0 Line Control Register | 00 | R/W | 196 |
| 00C4 | UART0_MCTL | UART 0 Modem Control Register | 00 | R/W | 198 |
| 00C5 | UART0_LSR | UART 0 Line Status Register | 60 | R | 200 |
| 00C6 | UART0_MSR | UART 0 Modem Status Register | XX | R | 202 |
| 00C7 | UART0_SPR | UART 0 Scratch Pad Register | 00 | R/W | 203 |
| I²C | | | | | |
| 00C8 | I2C_SAR | I ² C Slave Address Register | 00 | R/W | 232 |
| 00C9 | I2C_XSAR | I ² C Extended Slave Address Register | 00 | R/W | 233 |
| 00CA | I2C_DR | I ² C Data Register | 00 | R/W | 233 |
| 00CB | I2C_CTL | I ² C Control Register | 00 | R/W | 235 |
| 00CC | I2C_SR | I ² C Status Register | F8 | R | 236 |
| | I2C_CCR | I ² C Clock Control Register | 00 | W | 238 |
| 00CD | I2C_SRR | I ² C Software Reset Register | XX | W | 239 |

Notes:

1. After an external pin reset, the Watch-Dog Timer Control register is reset to 00h. After a Watch-Dog Timer time-out reset, the Watch-Dog Timer Control register is reset to 20h.
2. When the CPU reads this register, the current sampled value of the port is read.
3. Read Only if RTC is locked; Read/Write if RTC is unlocked.
4. After an external pin reset or a Watch-Dog Timer reset, the RTC Control register is reset to x0xxxx00b. After an RTC Alarm sleep-mode recovery reset, the RTC Control register is reset to x0xxxx10b.
5. Read Only if Flash Memory is locked. Read/Write if Flash Memory is unlocked.

Table 3. Register Map (Continued)

| Address (hex) | Mnemonic | Name | Reset (hex) | CPU Access | Page # |
|--|-------------|---|----------------|------------------|---------------------|
| Universal Asynchronous Receiver/Transmitter 1 (UART1) | | | | | |
| 00D0 | UART1_RBR | UART 1 Receive Buffer Register | XX | R | 192 |
| | UART1_THR | UART 1 Transmit Holding Register | XX | W | 191 |
| | UART1_BRG_L | UART 1 Baud Rate Generator Register—Low Byte | 02 | R/W | 190 |
| 00D1 | UART1_IER | UART 1 Interrupt Enable Register | 00 | R/W | 192 |
| | UART1_BRG_H | UART 1 Baud Rate Generator Register—High Byte | 00 | R/W | 190 |
| 00D2 | UART1_IIR | UART 1 Interrupt Identification Register | 01 | R | 193 |
| | UART1_FCTL | UART 1 FIFO Control Register | 00 | W | 195 |
| 00D3 | UART1_LCTL | UART 1 Line Control Register | 00 | R/W | 196 |
| 00D4 | UART1_MCTL | UART 1 Modem Control Register | 00 | R/W | 198 |
| 00D5 | UART1_LSR | UART 1 Line Status Register | 60 | R/W | 200 |
| 00D6 | UART1_MSR | UART 1 Modem Status Register | XX | R/W | 202 |
| 00D7 | UART1_SPR | UART 1 Scratch Pad Register | 00 | R/W | 203 |
| Low-Power Control | | | | | |
| 00DB | CLK_PPD1 | Clock Peripheral Power-Down Register 1 | 00 | R/W | 56 |
| 00DC | CLK_PPD2 | Clock Peripheral Power-Down Register 2 | 00 | R/W | 57 |
| Real-Time Clock | | | | | |
| 00E0 | RTC_SEC | RTC Seconds Register | XX | R/W ³ | 168 |
| 00E1 | RTC_MIN | RTC Minutes Register | XX | R/W ³ | 169 |
| 00E2 | RTC_HRS | RTC Hours Register | XX | R/W ³ | 170 |

Notes:

1. After an external pin reset, the Watch-Dog Timer Control register is reset to 00h. After a Watch-Dog Timer time-out reset, the Watch-Dog Timer Control register is reset to 20h.
2. When the CPU reads this register, the current sampled value of the port is read.
3. Read Only if RTC is locked; Read/Write if RTC is unlocked.
4. After an external pin reset or a Watch-Dog Timer reset, the RTC Control register is reset to x0xxxx00b. After an RTC Alarm sleep-mode recovery reset, the RTC Control register is reset to x0xxxx10b.
5. Read Only if Flash Memory is locked. Read/Write if Flash Memory is unlocked.

Table 3. Register Map (Continued)

| Address (hex) | Mnemonic | Name | Reset (hex) | CPU Access | Page # |
|-------------------------------------|-----------|---|--|------------------|---------------------|
| Real-Time Clock, continued | | | | | |
| 00E3 | RTC_DOW | RTC Day-of-the-Week Register | 0X | R/W ³ | 171 |
| 00E4 | RTC_DOM | RTC Day-of-the-Month Register | XX | R/W ³ | 172 |
| 00E5 | RTC_MON | RTC Month Register | XX | R/W ³ | 173 |
| 00E6 | RTC_YR | RTC Year Register | XX | R/W ³ | 174 |
| 00E7 | RTC_CEN | RTC Century Register | XX | R/W ³ | 175 |
| 00E8 | RTC_ASEC | RTC Alarm Seconds Register | XX | R/W | 176 |
| 00E9 | RTC_AMIN | RTC Alarm Minutes Register | XX | R/W | 177 |
| 00EA | RTC_AHRS | RTC Alarm Hours Register | XX | R/W | 178 |
| 00EB | RTC_ADOW | RTC Alarm Day-of-the-Week Register | 0X | R/W | 179 |
| 00EC | RTC_ACTRL | RTC Alarm Control Register | 00 | R/W | 180 |
| 00ED | RTC_CTRL | RTC Control Register | x0xxxx00 b/ x0xxxx10 b ⁴ | R/W | 181 |
| Chip Select Bus Mode Control | | | | | |
| 00F0 | CS0_BMC | Chip Select 0 Bus Mode Control Register | 02 | R/W | 96 |
| 00F1 | CS1_BMC | Chip Select 1 Bus Mode Control Register | 02 | R/W | 96 |
| 00F2 | CS2_BMC | Chip Select 2 Bus Mode Control Register | 02 | R/W | 96 |
| 00F3 | CS3_BMC | Chip Select 3 Bus Mode Control Register | 02 | R/W | 96 |
| Flash Memory Control | | | | | |
| 00F5 | FLASH_KEY | Flash Key Register | 00 | W | 110 |

Notes:

1. After an external pin reset, the Watch-Dog Timer Control register is reset to 00h. After a Watch-Dog Timer time-out reset, the Watch-Dog Timer Control register is reset to 20h.
2. When the CPU reads this register, the current sampled value of the port is read.
3. Read Only if RTC is locked; Read/Write if RTC is unlocked.
4. After an external pin reset or a Watch-Dog Timer reset, the RTC Control register is reset to x0xxxx00b. After an RTC Alarm sleep-mode recovery reset, the RTC Control register is reset to x0xxxx10b.
5. Read Only if Flash Memory is locked. Read/Write if Flash Memory is unlocked.



Table 3. Register Map (Continued)

| Address (hex) | Mnemonic | Name | Reset (hex) | CPU Access | Page # |
|--|--------------|---------------------------------------|----------------|------------------|---------------------|
| Flash Memory Control, continued | | | | | |
| 00F6 | FLASH_DATA | Flash Data Register | XX | R/W | 111 |
| 00F7 | FLASH_ADDR_U | Flash Address Upper Byte Register | 00 | R/W | 112 |
| 00F8 | FLASH_CTL | Flash Control Register | 88 | R/W | 113 |
| 00F9 | FLASH_FDIV | Flash Frequency Divider Register | 01 | R/W ⁵ | 114 |
| 00FA | FLASH_PROT | Flash Write/Erase Protection Register | FF | R/W ⁵ | 115 |
| 00FB | FLASH_IRQ | Flash Interrupt Control Register | 00 | R/W | 116 |
| 00FC | FLASH_PAGE | Flash Page Select Register | 00 | R/W | 118 |
| 00FD | FLASH_ROW | Flash Row Select Register | 00 | R/W | 119 |
| 00FE | FLASH_COL | Flash Column Select Register | 00 | R/W | 120 |
| 00FF | FLASH_PGCTL | Flash Program Control Register | 00 | R/W | 120 |

Notes:

1. After an external pin reset, the Watch-Dog Timer Control register is reset to 00h. After a Watch-Dog Timer time-out reset, the Watch-Dog Timer Control register is reset to 20h.
2. When the CPU reads this register, the current sampled value of the port is read.
3. Read Only if RTC is locked; Read/Write if RTC is unlocked.
4. After an external pin reset or a Watch-Dog Timer reset, the RTC Control register is reset to x0xxxx00b. After an RTC Alarm sleep-mode recovery reset, the RTC Control register is reset to x0xxxx10b.
5. Read Only if Flash Memory is locked. Read/Write if Flash Memory is unlocked.



eZ80[®] CPU Core

The eZ80[®] CPU is the first 8-bit CPU to support 16MB linear addressing. Each software module or task under a real-time executive or operating system can operate in Z80-compatible (64KB) mode or full 24-bit (16MB) address mode.

The CPU instruction set is a superset of the instruction sets for the Z80[™] and Z180[™] CPUs. Z80 and Z180 programs can be executed on an eZ80[®] CPU with little or no modification.

Features

- Code-compatible with Z80 and Z180 products
- 24-bit linear address space
- Single-cycle instruction fetch
- Pipelined fetch, decode, and execute
- Dual Stack Pointers for ADL (24-bit) and Z80 (16-bit) memory modes
- 24-bit CPU registers and ALU (Arithmetic Logic Unit)
- Debug support
- Nonmaskable Interrupt (NMI), plus support for 128 maskable vectored interrupts

New Instructions

- Loads/unloads the I register with a 16-bit value. These new instructions are:
 - LD I,HL (ED C7)
 - LD HL,I (ED D7)

For more information on the CPU, its instruction set, and eZ80 programming, please refer to the eZ80 CPU User Manual (UM0077), available on zilog.com.

Reset

Reset Operation

The Reset controller within the eZ80F91 device features a consistent reset function for all types of resets that can affect the system. A system reset, referred to in this document as RESET, returns the eZ80F91 to a defined state. All internal registers affected by a RESET return to their default conditions. RESET configures the GPIO port pins as inputs and clears the CPU's Program Counter to 000000h. Program code execution ceases during RESET.

The events that can cause a RESET are:

- Power-On Reset (POR)
- Low-voltage brown-out (VBO)
- External RESET pin assertion
- Watch-Dog Timer (WDT) time-out when configured to generate a RESET
- Real-Time Clock alarm with the CPU in low-power SLEEP mode
- Execution of a Debug RESET command

During RESET, an internal RESET mode timer holds the system in RESET for 1025 system clock (SCLK) cycles to allow sufficient time for the primary crystal oscillator to stabilize. For internal RESET sources, the RESET mode timer begins incrementing on the next rising edge of SCLK following deactivation of the signal that is initiating the RESET event. For external RESET pin assertion, the RESET mode timer begins on the next rising edge of SCLK following assertion of the RESET pin for three consecutive SCLK cycles.

- **Note:** The default clock source for SCLK on RESET is the crystal input (X_{IN}). Refer to the CLK_MUX values in the PLL Control Register 0, [Table 207](#) on page 325.

External Reset Input and Indicator

The eZ80F91 RESET pin functions as both an open-drain (active Low) RESET mode indicator and as an active Low RESET input. When a RESET event occurs, the internal circuitry begins driving the RESET pin Low. The RESET pin is held Low by the internal circuitry until the internal RESET mode timer times out. If the external reset signal is released prior to the end of the 1025-count time-out, program execution begins following the RESET mode time-out. If the external reset signal is released after the end of the 1025 count time-out, then program execution begins following release of the RESET input (the RESET pin is High for four consecutive SCLK cycles).

Power-On Reset

A Power-On Reset (POR) occurs each time the supply voltage to the part rises from below the voltage brown-out threshold (V_{VBO}) to above the POR voltage threshold (V_{POR}). The internal bandgap-referenced voltage detector sends a continuous RESET signal to the Reset controller until the supply voltage (V_{CC}) exceeds the POR voltage threshold. After V_{CC} rises above V_{POR} , an on-chip analog delay element briefly maintains the RESET signal to the Reset controller. After this analog delay element times out, the Reset controller holds the eZ80F91 in RESET until the RESET mode timer expires. POR operation is illustrated in Figure 3. The signals in Figure 3 are not drawn to scale, but are for illustration purposes only.

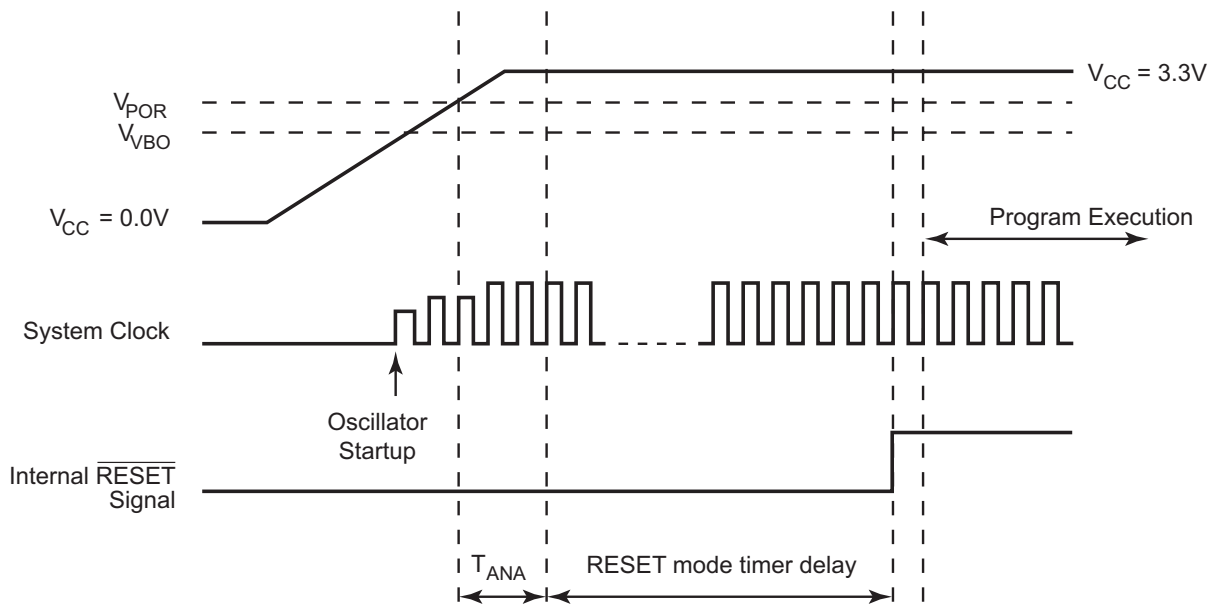

Figure 3. Power-On Reset Operation

Voltage Brown-Out Reset

If, after program execution begins, the supply voltage (V_{CC}) drops below the voltage brown-out threshold (V_{VBO}), the eZ80F91 device resets. The VBO protection circuitry detects the low supply voltage and initiates a RESET via the Reset controller. The eZ80F91 remains in RESET until the supply voltage again returns above the POR voltage threshold (V_{POR}) and the Reset controller releases the internal RESET signal. The VBO circuitry rejects very short negative brown-out pulses to prevent spurious RESET events.



VBO operation is illustrated in Figure 4. The signals in the figure are not drawn to scale, and are for illustration purposes only.

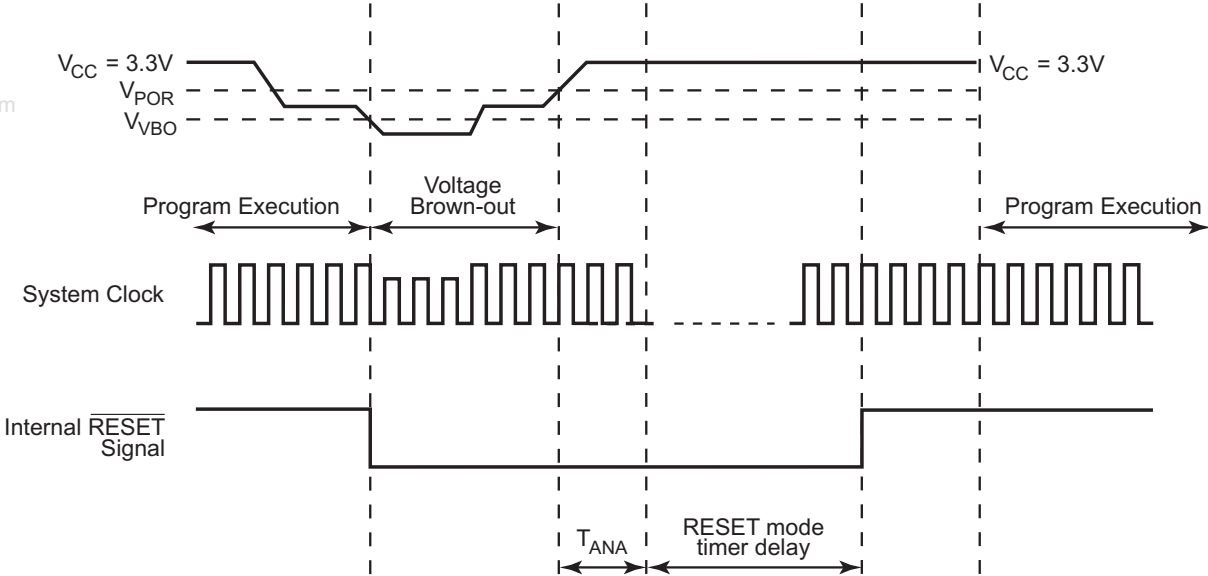

Figure 4. Voltage Brown-Out Reset Operation

Low Power Modes

Overview

The eZ80F91 device provides a range of power-saving features. The highest level of power reduction is provided by SLEEP mode. The next level of power reduction is provided by the HALT instruction. The most basic level of power reduction is provided by the clock peripheral power-down registers.

SLEEP Mode

Execution of the CPU's SLP instruction places the eZ80F91 device into SLEEP mode. In SLEEP mode, the operating characteristics are:

- The primary crystal oscillator is disabled
- The system clock is disabled
- The CPU is idle
- The Program Counter (PC) stops incrementing
- The 32KHz crystal oscillator continues to operate and drive the Real-Time Clock and the Watch-Dog Timer (if WDT is configured to operate from the 32KHz oscillator)

The CPU can be brought out of SLEEP mode by any of the following operations:

- A RESET via the external $\overline{\text{RESET}}$ pin driven Low
- A RESET via a Real-Time Clock alarm
- A RESET via a Watch-Dog Timer time-out (if running off of the 32KHz oscillator and configured to generate a RESET upon time-out)
- A RESET via execution of a Debug RESET command

After exiting SLEEP mode, the standard RESET delay occurs to allow the primary crystal oscillator to stabilize. Refer to the [Reset](#) section on page 51 for more information.

HALT Mode

Execution of the CPU's HALT instruction places the eZ80F91 device into HALT mode. In HALT mode, the operating characteristics are:

- The primary crystal oscillator is enabled and continues to operate

- The system clock is enabled and continues to operate
- The CPU is idle
- The Program Counter (PC) stops incrementing

The CPU can be brought out of HALT mode by any of the following operations:

- A nonmaskable interrupt (NMI)
- A maskable interrupt
- A RESET via the external $\overline{\text{RESET}}$ pin driven Low
- A Watch-Dog Timer time-out (if configured to generate either an NMI or RESET upon time-out)
- A RESET via execution of a Debug RESET command

To minimize current in HALT mode, the system clock should be gated off for all unused on-chip peripherals via the Clock Peripheral Power-Down Registers.

HALT Mode and the EMAC Function

When the CPU is in HALT mode, the eZ80F91 device's EMAC block cannot be disabled as can other peripherals. Upon receipt of an Ethernet packet, a maskable Receive interrupt is generated by the EMAC block, just as it would be in a non-halt mode. Accordingly, the processor wakes up and continues with the user-defined application.

Clock Peripheral Power-Down Registers

To reduce power, the Clock Peripheral Power-Down Registers allow the system clock to be blocked to unused on-chip peripherals. Upon RESET, all peripherals are enabled. The clock to unused peripherals can be gated off by setting the appropriate bit in the Clock Peripheral Power-Down Registers to 1. When powered down, the peripherals are completely disabled. To reenabling, the bit in the Clock Peripheral Power-Down Registers must be cleared to 0.

Many peripherals feature separate enable/disable control bits that must be appropriately set for operation. These peripheral specific enable/disable bits do not provide the same level of power reduction as the Clock Peripheral Power-Down Registers. When powered down, the individual peripheral control register is not accessible for Read or Write access. See Tables 4 and 5.



Table 4. Clock Peripheral Power-Down Register 1
(CLK_PPD1 = 00DBh)

| Bit | 7 | 6 | 5 | 4 | 3 | 2 | 1 | 0 |
|-------------------|-----|-----|-----|-----|-----|-----|-----|-----|
| Reset | 0 | 0 | 0 | 0 | 0 | 0 | 0 | 0 |
| CPU Access | R/W | R/W | R/W | R/W | R/W | R/W | R/W | R/W |

Note: R/W = Read/Write.

| Bit Position | Value | Description |
|-----------------|-------|---|
| 7 GPIO_D_OFF | 1 | System clock to GPIO Port D is powered down. Port D alternate functions do not operate correctly. |
| | 0 | System clock to GPIO Port D is powered up. |
| 6 GPIO_C_OFF | 1 | System clock to GPIO Port C is powered down. Port C alternate functions do not operate correctly. |
| | 0 | System clock to GPIO Port C is powered up. |
| 5 GPIO_B_OFF | 1 | System clock to GPIO Port B is powered down. Port B alternate functions do not operate correctly. |
| | 0 | System clock to GPIO Port B is powered up. |
| 4 GPIO_A_OFF | 1 | System clock to GPIO Port A is powered down. Port A alternate functions do not operate correctly. |
| | 0 | System clock to GPIO Port A is powered up. |
| 3 SPI_OFF | 1 | System clock to SPI is powered down. |
| | 0 | System clock to SPI is powered up. |
| 2 I2C_OFF | 1 | System clock to I ² C is powered down. |
| | 0 | System clock to I ² C is powered up. |
| 1 UART1_OFF | 1 | System clock to UART1 is powered down. |
| | 0 | System clock to UART1 is powered up. |
| 0 UART0_OFF | 1 | System clock to UART0 and IrDA endec is powered down. |
| | 0 | System clock to UART0 and IrDA endec is powered up. |



**Table 5. Clock Peripheral Power-Down Register 2
(CLK_PPD2 = 00DCh)**

| Bit | 7 | 6 | 5 | 4 | 3 | 2 | 1 | 0 |
|-------------------|-----|---|---|---|-----|-----|-----|-----|
| Reset | 0 | 0 | 0 | 0 | 0 | 0 | 0 | 0 |
| CPU Access | R/W | R | R | R | R/W | R/W | R/W | R/W |

Note: R = Read Only; R/W = Read/Write.

| Bit Position | Value | Description |
|-----------------|-------|--|
| 7 PHI_OFF | 1 | PHI Clock output is disabled (output is high-impedance). |
| | 0 | PHI Clock output is enabled. |
| [6:4] | 000 | Reserved. |
| 3 TIMER3_OFF | 1 | System clock to TIMER3 is powered down. |
| | 0 | System clock to TIMER3 is powered up. |
| 2 TIMER2_OFF | 1 | System clock to TIMER2 is powered down. |
| | 0 | System clock to TIMER2 is powered up. |
| 1 TIMER1_OFF | 1 | System clock to TIMER1 is powered down. |
| | 0 | System clock to TIMER1 is powered up. |
| 0 TIMER0_OFF | 1 | System clock to TIMER0 is powered down. |
| | 0 | System clock to TIMER0 is powered up. |

General-Purpose Input/Output

GPIO Overview

The eZ80F91 device features 32 General-Purpose Input/Output (GPIO) pins. The GPIO pins are assembled as four 8-bit ports— Port A, Port B, Port C, and Port D. All port signals can be configured for use as either inputs or outputs. In addition, all of the port pins can be used as vectored interrupt sources for the CPU.

The eZ80F91 microcontroller's GPIO ports are slightly modified from its eZ80[®] predecessors. Specifically, Port A pins now can source 8mA and sink 10mA. In addition, the Port B and C inputs now feature Schmitt-trigger input buffers.

GPIO Operation

GPIO operation is the same for all four GPIO ports (Ports A, B, C, and D). Each port features eight GPIO port pins. The operating mode for each pin is controlled by four bits that are divided between four 8-bit registers. These GPIO mode control registers are:

- Port *x* Data Register (Px_DR)
- Port *x* Data Direction Register (Px_DDR)
- Port *x* Alternate Register 1 (Px_ALT1)
- Port *x* Alternate Register 2 (Px_ALT2)

where *x* can be *A*, *B*, *C*, or *D* representing any of the four GPIO ports A, B, C, or D. The mode for each pin is controlled by setting each register bit pertinent to the pin to be configured. For example, the operating mode for Port B Pin 7 (PB7) is set by the values contained in PB_DR[7], PB_DDR[7], PB_ALT1[7], and PB_ALT2[7].

The combination of the GPIO control register bits allows individual configuration of each port pin for nine modes. In all modes, reading of the Port *x* Data register returns the sampled state, or level, of the signal on the corresponding pin. Table 6 indicates the function of each port signal based upon these four register bits. After a RESET event, all GPIO port pins are configured as standard digital inputs (GPIO Mode 2), with interrupts disabled.



Table 6. GPIO Mode Selection

| GPIO Mode | Px_ALT2 Bits7:0 | Px_ALT1 Bits7:0 | Px_DDR Bits7:0 | Px_DR Bits7:0 | Port Mode | Output |
|-----------|-----------------|-----------------|----------------|---------------|---|----------------|
| 1 | 0 | 0 | 0 | 0 | Output | 0 |
| | 0 | 0 | 0 | 1 | Output | 1 |
| 2 | 0 | 0 | 1 | 0 | Input from pin | High impedance |
| | 0 | 0 | 1 | 1 | Input from pin | High impedance |
| 3 | 0 | 1 | 0 | 0 | Open-drain output | 0 |
| | 0 | 1 | 0 | 1 | Open-drain I/O | High impedance |
| 4 | 0 | 1 | 1 | 0 | Open-source I/O | High impedance |
| | 0 | 1 | 1 | 1 | Open-source output | 1 |
| 5 | 1 | 0 | 0 | 0 | Reserved | High impedance |
| 6 | 1 | 0 | 0 | 1 | Interrupt—dual edge-triggered | High impedance |
| 7 | 1 | 0 | 1 | 0 | Port B, C, or D—alternate function controls port I/O. | |
| | 1 | 0 | 1 | 1 | Port B, C, or D—alternate function controls port I/O. | |
| 8 | 1 | 1 | 0 | 0 | Interrupt—active Low | High impedance |
| | 1 | 1 | 0 | 1 | Interrupt—active High | High impedance |
| 9 | 1 | 1 | 1 | 0 | Interrupt—falling edge-triggered | High impedance |
| | 1 | 1 | 1 | 1 | Interrupt—rising edge-triggered | High impedance |

GPIO Mode 1. The port pin is configured as a standard digital output pin. The value written to the Port x Data register (Px_DR) is presented on the pin.

GPIO Mode 2. The port pin is configured as a standard digital input pin. The output is tristated (high impedance). The value stored in the Port x Data register produces no effect. As in all modes, a Read from the Port x Data register returns the pin's value. GPIO Mode 2 is the default operating mode following a RESET.

GPIO Mode 3. The port pin is configured as open-drain I/O. The GPIO pins do not feature an internal pull-up to the supply voltage. To employ the GPIO pin in OPEN-DRAIN mode, an external pull-up resistor must connect the pin to the supply voltage. Writing a 0 to the Port x Data register outputs a Low at the pin. Writing a 1 to the Port x Data register results in high-impedance output.

GPIO Mode 4. The port pin is configured as open-source I/O. The GPIO pins do not feature an internal pull-down to the supply ground. To employ the GPIO pin in OPEN-SOURCE mode, an external pull-down resistor must connect the pin to the

supply ground. Writing a 1 to the Port x Data register outputs a High at the pin. Writing a 0 to the Port x Data register results in a high-impedance output.

GPIO Mode 5. Reserved. This pin produces high-impedance output.

GPIO Mode 6. This bit enables a dual edge-triggered interrupt mode. Both a rising and a falling edge on the pin cause an interrupt request to be sent to the CPU. Writing a 1 to the Port x Data register bit position resets the corresponding interrupt request. Writing a 0 produces no effect. The programmer must set the Port x Data register before entering the edge-triggered interrupt mode.

GPIO Mode 7. For Ports B, C, and D, the port pin is configured to pass control over to the alternate (secondary) functions assigned to the pin. For example, the alternate mode function for PC7 is RI1 and the alternate mode function for PB4 is the Timer 4 output. When GPIO Mode 7 is enabled, the pin output data and pin tristated control come from the alternate function's data output and tristate control, respectively. The value in the Port x Data register produces no effect on operation. Input signals are sampled by the system clock before being passed to the alternate function input.

► **Note:** Alternate function inputs are routed to the associated functional block regardless of the GPIO mode setting.

Px_DDR does not indicate the GPIO direction in all alternate function modes.

GPIO Mode 8. The port pin is configured for level-sensitive interrupt modes. An interrupt request is generated when the level at the pin is the same as the level stored in the Port x Data register. The port pin value is sampled by the system clock. The input pin must be held at the selected interrupt level for a minimum of 2 clock periods to initiate an interrupt. The interrupt request remains active as long as this condition is maintained at the external source.

GPIO Mode 9. The port pin is configured for single edge-triggered interrupt mode. The value in the Port x Data register determines if a positive or negative edge causes an interrupt request. Writing a 0 to the Port x Data register bit sets the selected pin to generate an interrupt request for falling edges. Writing a 1 to the Port x Data register bit sets the selected pin to generate an interrupt request for rising edges. Any time a port pin is configured for an edge-trigger interrupt, writing a 1 to the Port x Data register causes a reset of the edge-trigger interrupt. Writing a 0 produces no effect on operation. The programmer must set the Port x Data register before entering the single- or dual-edge-triggered interrupt mode.

A simplified block diagram of a GPIO port pin is illustrated in Figure 5.

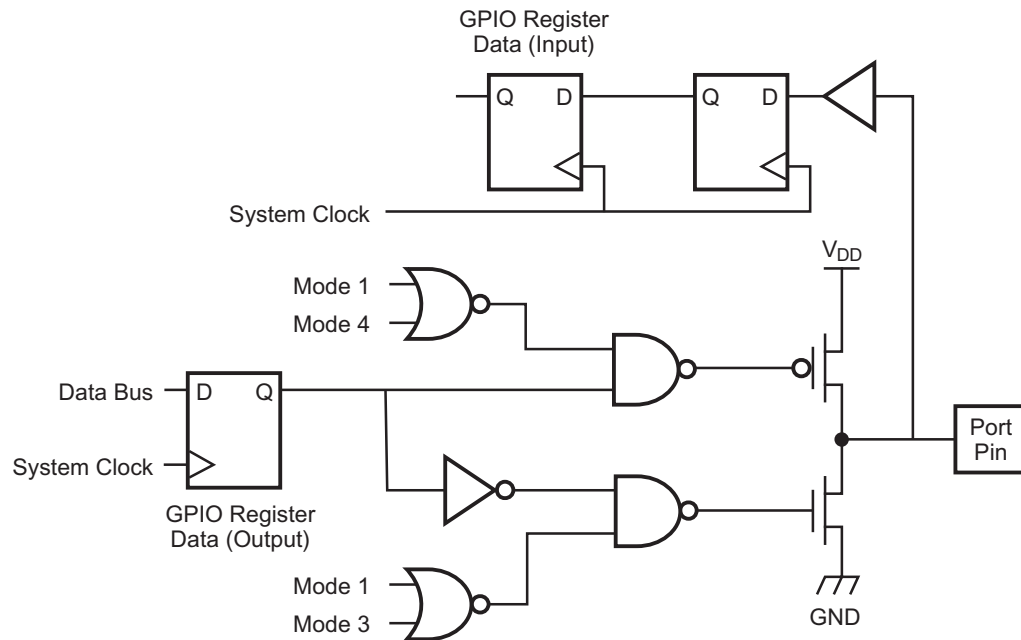

Figure 5. GPIO Port Pin Block Diagram

GPIO Interrupts

Each port pin can be used as an interrupt source. Interrupts can be either level- or edge-triggered.

Level-Triggered Interrupts

When the port is configured for level-triggered interrupts, the corresponding port pin is tristated. An interrupt request is generated when the level at the pin is the same as the level stored in the Port x Data register. The port pin value is sampled by the system clock. The input pin must be held at the selected interrupt level for a minimum of 2 clock periods to initiate an interrupt. The interrupt request remains active as long as this condition is maintained at the external source.

For example, if PA3 is programmed for low-level interrupt and the pin is forced Low for 2 clock cycles, an interrupt request signal is generated from that port pin and sent to the CPU. The interrupt request signal remains active until the external device driving PA3 forces the pin High. The CPU must be enabled to respond to interrupts for the interrupt request signal to be acted upon.

Edge-Triggered Interrupts

When the port is configured for edge-triggered interrupts, the corresponding port pin is tristated. If the pin receives the correct edge from an external device, the port pin generates an interrupt request signal to the CPU. Any time a port pin is configured for an edge-triggered interrupt, writing a 1 to that pin's Port x Data register causes a reset of an edge-detected interrupt. The programmer must set the bit in the Port x Data register to 1 before entering either single or dual edge-triggered interrupt mode for that port pin.

When configured for dual edge-triggered interrupt mode (GPIO Mode 6), both a rising and a falling edge on the pin cause an interrupt request to be sent to the CPU.

When configured for single edge-triggered interrupt mode (GPIO Mode 9), the value in the Port x Data register determines if a positive or negative edge causes an interrupt request. A 0 in the Port x Data register bit sets the selected pin to generate an interrupt request for falling edges. A 1 in the Port x Data register bit sets the selected pin to generate an interrupt request for rising edges.

GPIO Control Registers

The 16 GPIO Control Registers operate in groups of four with a set for each Port (A, B, C, and D). Each GPIO port features a Port Data register, Port Data Direction register, Port Alternate register 1, and Port Alternate register 2.

Port x Data Registers

When the port pins are configured for one of the output modes, the data written to the Port x Data registers, detailed in Table 7, is driven on the corresponding pins. In all modes, reading from the Port x Data registers always returns the current sampled value of the corresponding pins. When the port pins are configured as edge-triggered interrupt sources, writing a 1 to the corresponding bit in the Port x Data register clears the interrupt signal that is sent to the CPU. When the port pins are configured for edge-selectable interrupts or level-sensitive interrupts, the value written to the Port x Data register bit selects the interrupt edge or interrupt level. See [Table 6](#) for more information.



Table 7. Port x Data Registers
(PA_DR = 0096h, PB_DR = 009Ah, PC_DR = 009Eh, PD_DR = 00A2h)

| Bit | 7 | 6 | 5 | 4 | 3 | 2 | 1 | 0 |
|------------|-----|-----|-----|-----|-----|-----|-----|-----|
| Reset | X | X | X | X | X | X | X | X |
| CPU Access | R/W | R/W | R/W | R/W | R/W | R/W | R/W | R/W |

Note: X = Undefined; R/W = Read/Write.

Port x Data Direction Registers

In conjunction with the other GPIO Control Registers, the Port x Data Direction registers, detailed in Table 8, control the operating modes of the GPIO port pins. See [Table 6](#) for more information. Px_DDR does not indicate the GPIO direction in all alternate function modes.

Table 8. Port x Data Direction Registers
(PA_DDR = 0097h, PB_DDR = 009Bh, PC_DDR = 009Fh, PD_DDR = 00A3h)

| Bit | 7 | 6 | 5 | 4 | 3 | 2 | 1 | 0 |
|------------|-----|-----|-----|-----|-----|-----|-----|-----|
| Reset | 1 | 1 | 1 | 1 | 1 | 1 | 1 | 1 |
| CPU Access | R/W | R/W | R/W | R/W | R/W | R/W | R/W | R/W |

Note: R/W = Read/Write.

Port x Alternate Register 1

In conjunction with the other GPIO Control Registers, the Port x Alternate Register 1, detailed in Table 9, controls the operating modes of the GPIO port pins. Px_DDR does not indicate the GPIO direction in all alternate function modes. See [Table 6](#) for more information.

Table 9. Port x Alternate Registers 1
(PA_ALT1 = 0098h, PB_ALT1 = 009Ch, PC_ALT1 = 00A0h, PD_ALT1 = 00A4h)

| Bit | 7 | 6 | 5 | 4 | 3 | 2 | 1 | 0 |
|------------|-----|-----|-----|-----|-----|-----|-----|-----|
| Reset | 0 | 0 | 0 | 0 | 0 | 0 | 0 | 0 |
| CPU Access | R/W | R/W | R/W | R/W | R/W | R/W | R/W | R/W |

Note: R/W = Read/Write.



Port x Alternate Register 2

In conjunction with the other GPIO Control Registers, the Port x Alternate Register 2, detailed in Table 10, controls the operating modes of the GPIO port pins. See [Table 6](#) for more information.

Table 10. Port x Alternate Registers 2
(PA_ALT2 = 0099h, PB_ALT2 = 009Dh, PC_ALT2 = 00A1h, PD_ALT2 = 00A5h)

| Bit | 7 | 6 | 5 | 4 | 3 | 2 | 1 | 0 |
|-------------------|-----|-----|-----|-----|-----|-----|-----|-----|
| Reset | 0 | 0 | 0 | 0 | 0 | 0 | 0 | 0 |
| CPU Access | R/W | R/W | R/W | R/W | R/W | R/W | R/W | R/W |

Note: R/W = Read/Write.



Interrupt Controller

The interrupt controller on the eZ80F91 device routes the interrupt request signals from the internal peripherals, external devices (via the internal port I/O), and the nonmaskable interrupt (NMI) pin to the CPU.

www.DataSheet4U.com

Maskable Interrupts

On the eZ80F91 device, all maskable interrupts use the CPU's vectored interrupt function. The size of the I register is modified to 16 bits in the eZ80F91 device, differing from that of previous versions of the eZ80[®] CPU, to allow for a 16MB range of interrupt vector table placement. Additionally, the size of the IVECT register is increased from 8 bits to 9 bits to provide an interrupt vector table that can be expanded and is more easily integrated with other interrupts.

The vectors are 4 bytes (32 bits) apart, even though only 3 bytes (24 bits) are required. A fourth byte is implemented for both programmability and expansion purposes.

Starting the interrupt vectors at 40h allows for easy implementation of the interrupt controller vectors with the RST vectors. Table 11 lists the low-byte vector for each of the maskable interrupt sources. The maskable interrupt sources are listed in order of their priority, with vector 40h being the highest-priority interrupt. In ADL mode, the full 24-bit interrupt vector is located at starting address {I[15:1], IVECT[8:0]}, where I[15:0] is the CPU's Interrupt Page Address Register.

Table 11. Interrupt Vector Sources by Priority

| Priority | Vector | Source | Priority | Vector | Source |
|----------|--------|----------|----------|--------|----------|
| 0 | 040h | EMAC Rx | 24 | 0A0h | Port B 0 |
| 1 | 044h | EMAC Tx | 25 | 0A4h | Port B 1 |
| 2 | 048h | EMAC SYS | 26 | 0A8h | Port B 2 |
| 3 | 04Ch | PLL | 27 | 0ACh | Port B 3 |
| 4 | 050h | Flash | 28 | 0B0h | Port B 4 |
| 5 | 054h | Timer 0 | 29 | 0B4h | Port B 5 |
| 6 | 058h | Timer 1 | 30 | 0B8h | Port B 6 |
| 7 | 05Ch | Timer 2 | 31 | 0BCh | Port B 7 |
| 8 | 060h | Timer 3 | 32 | 0C0h | Port C 0 |

Note: *The vector addresses 064h and 068h are left unused to avoid conflict with the nonmaskable interrupt (NMI) address 066h. The NMI is prioritized higher than all maskable interrupts.



Table 11. Interrupt Vector Sources by Priority (Continued)

| Priority | Vector | Source | Priority | Vector | Source |
|----------|--------|------------------|----------|--------|----------|
| 9 | 064h | unused* | 33 | 0C4h | Port C 1 |
| 10 | 068h | unused* | 34 | 0C8h | Port C 2 |
| 11 | 06Ch | RTC | 35 | 0CCh | Port C 3 |
| 12 | 070h | UART 0 | 36 | 0D0h | Port C 4 |
| 13 | 074h | UART 1 | 37 | 0D4h | Port C 5 |
| 14 | 078h | I ² C | 38 | 0D8h | Port C 6 |
| 15 | 07Ch | SPI | 39 | 0DCh | Port C 7 |
| 16 | 080h | Port A 0 | 40 | 0E0h | Port D 0 |
| 17 | 084h | Port A 1 | 41 | 0E4h | Port D 1 |
| 18 | 088h | Port A 2 | 42 | 0E8h | Port D 2 |
| 19 | 08Ch | Port A 3 | 43 | 0ECh | Port D 3 |
| 20 | 090h | Port A 4 | 44 | 0F0h | Port D 4 |
| 21 | 094h | Port A 5 | 45 | 0F4h | Port D 5 |
| 22 | 098h | Port A 6 | 46 | 0F8h | Port D 6 |
| 23 | 09Ch | Port A 7 | 47 | 0FCh | Port D 7 |

Note: *The vector addresses 064h and 068h are left unused to avoid conflict with the nonmaskable interrupt (NMI) address 066h. The NMI is prioritized higher than all maskable interrupts.

The user's program should store the interrupt service routine starting address in the four-byte interrupt vector locations. As an example, in ADL mode, the three-byte address for the SPI interrupt service routine is be stored at {I[15:1], 07Ch}, {I[15:1], 07Dh} and {I[15:1], 07Eh}. In Z80 mode, the two-byte address for the SPI interrupt service routine is be stored at {MBASE[7:0], I[7:1], 07Ch} and {MBASE, I[7:1], 07Dh}. The least-significant byte is stored at the lower address.

When any one or more of the interrupt requests (IRQs) become active, an interrupt request is generated by the interrupt controller and sent to the CPU. The corresponding 9-bit interrupt vector for the highest-priority interrupt is placed on the 9-bit interrupt vector bus, IVECT[8:0]. The interrupt vector bus is internal to the eZ80F91 device and is therefore not visible externally. The response time of the CPU to an interrupt request is a function of the current instruction being executed as well as the number of wait states being asserted. The interrupt vector, {I[15:1], IVECT[8:0]}, is visible on the address bus, ADDR[23:0], when the interrupt service routine begins. The response of the CPU to a vectored interrupt on the eZ80F91

device is explained in Table 12. Interrupt sources are required to be active until the interrupt service routine (ISR) starts.

- **Note:** The lower bit of the I register is replaced with the MSB of the IVECT from the interrupt controller. As a result, the interrupt vector table is required to be placed onto a 512-byte boundary. Setting the LSB of the I register produces no effect on the interrupt vector address.

www.DataSheet4U.com

Table 12. Vectored Interrupt Operation

| Memory Mode | ADL Bit | MADL Bit | Operation |
|-------------|---------|----------|---|
| Z80 Mode | 0 | 0 | <p>Read the LSB of the interrupt vector placed on the internal vectored interrupt bus, IVECT [8:0], by the interrupting peripheral.</p> <ul style="list-style-type: none"> • IEF1 ← 0 • IEF2 ← 0 • The Starting Program Counter is effectively {MBASE, PC[15:0]}. • Push the 2-byte return address PC[15:0] onto the ({MBASE,SPS}) stack. • The ADL mode bit remains cleared to 0. • The interrupt vector address is located at { MBASE, I[7:1], IVECT[8:0] }. • PC[23:0] ← ({ MBASE, I[7:1], IVECT[8:0] }). • The interrupt service routine must end with RETI. |
| ADL Mode | 1 | 0 | <p>Read the LSB of the interrupt vector placed on the internal vectored interrupt bus, IVECT [8:0], by the interrupting peripheral.</p> <ul style="list-style-type: none"> • IEF1 ← 0 • IEF2 ← 0 • The Starting Program Counter is PC[23:0]. • Push the 3-byte return address, PC[23:0], onto the SPL stack. • The ADL mode bit remains set to 1. • The interrupt vector address is located at { I[15:1], IVECT[8:0] }. • PC[23:0] ← ({ I[15:1], IVECT[8:0] }). • The interrupt service routine must end with RETI. |

Table 12. Vectored Interrupt Operation (Continued)

| Memory Mode | ADL Bit | MADL Bit | Operation |
|-------------|---------|----------|---|
| Z80 Mode | 0 | 1 | <p>Read the LSB of the interrupt vector placed on the internal vectored interrupt bus, IVECT[8:0], bus by the interrupting peripheral.</p> <ul style="list-style-type: none"> • IEF1 ← 0 • IEF2 ← 0 • The Starting Program Counter is effectively {MBASE, PC[15:0]}. • Push the 2-byte return address, PC[15:0], onto the SPL stack. • Push a 00h byte onto the SPL stack to indicate an interrupt from Z80 mode (because ADL = 0). • Set the ADL mode bit to 1. • The interrupt vector address is located at { I[15:1], IVECT[8:0] }. • PC[23:0] ← ({ I[15:1], IVECT[8:0] }). • The interrupt service routine must end with RETI.L |
| ADL Mode | 1 | 1 | <p>Read the LSB of the interrupt vector placed on the internal vectored interrupt bus, IVECT [8:0], by the interrupting peripheral.</p> <ul style="list-style-type: none"> • IEF1 ← 0 • IEF2 ← 0 • The Starting Program Counter is PC[23:0]. • Push the 3-byte return address, PC[23:0], onto the SPL stack. • Push a 01h byte onto the SPL stack to indicate a restart from ADL mode (because ADL = 1). • The ADL mode bit remains set to 1. • The interrupt vector address is located at {I[15:1], IVECT[8:0]}. • PC[23:0] ← ({ I[15:1], IVECT[8:0] }). • The interrupt service routine must end with RETI.L |

Interrupt Priority Registers

The eZ80F91 provides two interrupt priority levels for the maskable interrupts. The default priority (or Level 0) is indicated in [Table 11](#). The default priority of any maskable interrupt can increase to Level 1 (a higher priority than any Level 0 interrupt) by setting the appropriate bit in the Interrupt Priority Registers, which are shown in Table 13.



Table 13. Interrupt Priority Registers
(INT_P0 = 0010h, INT_P1 = 0011h, INT_P2 = 0012h,
INT_P3 = 0013h, INT_P4 = 0014h, INT_P5 = 0015h)

| Bit | 7 | 6 | 5 | 4 | 3 | 2 | 1 | 0 |
|--------------|-----|-----|-----|-----|-----|-----|-----|-----|
| INT_P0 Reset | 0 | 0 | 0 | 0 | 0 | 0 | 0 | 0 |
| INT_P1 Reset | 0 | 0 | 0 | 0 | 0 | 0* | 0* | 0 |
| INT_P2 Reset | 0 | 0 | 0 | 0 | 0 | 0 | 0 | 0 |
| INT_P3 Reset | 0 | 0 | 0 | 0 | 0 | 0 | 0 | 0 |
| INT_P4 Reset | 0 | 0 | 0 | 0 | 0 | 0 | 0 | 0 |
| INT_P5 Reset | 0 | 0 | 0 | 0 | 0 | 0 | 0 | 0 |
| CPU Access | R/W | R/W | R/W | R/W | R/W | R/W | R/W | R/W |

Note: X = Undefined; R/W = Read/Write, *Unused.

| Bit Position | Value | Description |
|--------------|-------|------------------------------|
| 7 INT_PX | 0 | Default Interrupt Priority |
| | 1 | Level One Interrupt Priority |
| 6 INT_PX | 0 | Default Interrupt Priority |
| | 1 | Level One Interrupt Priority |
| 5 INT_PX | 0 | Default Interrupt Priority |
| | 1 | Level One Interrupt Priority |
| 4 INT_PX | 0 | Default Interrupt Priority |
| | 1 | Level One Interrupt Priority |
| 3 INT_PX | 0 | Default Interrupt Priority |
| | 1 | Level One Interrupt Priority |
| 2 INT_PX | 0 | Default Interrupt Priority |
| | 1 | Level One Interrupt Priority |
| 1 INT_PX | 0 | Default Interrupt Priority |
| | 1 | Level One Interrupt Priority |
| 0 INT_PX | 0 | Default Interrupt Priority |
| | 1 | Level One Interrupt Priority |

The Interrupt Priority Control bits are shown in Table 14.

Table 14. Interrupt Vector Priority Control Bits

| Priority Control Bit | Vector | Source | Priority Control Bit | Vector | Source |
|----------------------|--------|------------------|----------------------|--------|----------|
| INT_P0[0] | 040h | EMAC Rx | INT_P3[0] | 0A0h | Port B 0 |
| INT_P0[1] | 044h | EMAC Tx | INT_P3[1] | 0A4h | Port B 1 |
| INT_P0[2] | 048h | EMAC SYS | INT_P3[2] | 0A8h | Port B 2 |
| INT_P0[3] | 04Ch | PLL | INT_P3[3] | 0ACh | Port B 3 |
| INT_P0[4] | 050h | Flash | INT_P3[4] | 0B0h | Port B 4 |
| INT_P0[5] | 054h | Timer 0 | INT_P3[5] | 0B4h | Port B 5 |
| INT_P0[6] | 058h | Timer 1 | INT_P3[6] | 0B8h | Port B 6 |
| INT_P0[7] | 05Ch | Timer 2 | INT_P3[7] | 0BCh | Port B 7 |
| INT_P1[0] | 060h | Timer 3 | INT_P4[0] | 0C0h | Port C 0 |
| INT_P1[1] | 064h | unused* | INT_P4[1] | 0C4h | Port C 1 |
| INT_P1[2] | 068h | unused* | INT_P4[2] | 0C8h | Port C 2 |
| INT_P1[3] | 06Ch | RTC | INT_P4[3] | 0CCh | Port C 3 |
| INT_P1[4] | 070h | UART 0 | INT_P4[4] | 0D0h | Port C 4 |
| INT_P1[5] | 074h | UART 1 | INT_P4[5] | 0D4h | Port C 5 |
| INT_P1[6] | 078h | I ² C | INT_P4[6] | 0D8h | Port C 6 |
| INT_P1[7] | 07Ch | SPI | INT_P4[7] | 0DCh | Port C 7 |
| INT_P2[0] | 080h | Port A 0 | INT_P5[0] | 0E0h | Port D 0 |
| INT_P2[1] | 084h | Port A 1 | INT_P5[1] | 0E4h | Port D 1 |
| INT_P2[2] | 088h | Port A 2 | INT_P5[2] | 0E8h | Port D 2 |
| INT_P2[3] | 08Ch | Port A 3 | INT_P5[3] | 0ECh | Port D 3 |
| INT_P2[4] | 090h | Port A 4 | INT_P5[4] | 0F0h | Port D 4 |
| INT_P2[5] | 094h | Port A 5 | INT_P5[5] | 0F4h | Port D 5 |
| INT_P2[6] | 098h | Port A 6 | INT_P5[6] | 0F8h | Port D 6 |
| INT_P2[7] | 09Ch | Port A 7 | INT_P5[7] | 0FCh | Port D 7 |

Note: *The vector addresses 064h and 068h are left unused to avoid conflict with the NMI vector address 066h.

If more than one maskable interrupt is prioritized to a higher level (Level 1), the higher-priority interrupts follow the priority order described in [Table 11](#). For example, Table 15 shows the maskable interrupts 044h (EMAC Tx), 084h (Port A 1), and 06Ch (RTC) as elevated to Priority Level 1. Table 16 shows the new interrupt priority for the top ten maskable interrupts.

Table 15. Example: Maskable Interrupt Priority

| Priority Register | Setting | Description |
|-------------------|---------|---|
| INT_P0 | 02h | Increase 044h (EMAC Tx) to Priority Level 1 |
| INT_P1 | 08h | Increase 06Ch (RTC) to Priority Level 1 |
| INT_P2 | 02h | Increase 084h (Port A1) to Priority Level 1 |
| INT_P3 | 00h | Default priority |
| INT_P4 | 00h | Default priority |
| INT_P5 | 00h | Default priority |

Table 16. Example: Priority Levels for Maskable Interrupts

| Priority | Vector | Source |
|----------|--------|----------|
| 0 | 044h | EMAC Tx |
| 1 | 06Ch | RTC |
| 2 | 084h | Port A 1 |
| 3 | 040h | EMAC Rx |
| 4 | 048h | EMAC SYS |
| 5 | 04Ch | PLL |
| 6 | 050h | Flash |
| 7 | 054h | Timer 0 |
| 8 | 058h | Timer 1 |
| 9 | 05Ch | Timer 2 |

GPIO Port Interrupts

All interrupts are latched. In effect, an interrupt is held even if the interrupt occurs while another interrupt is being serviced and interrupts are disabled, or if the interrupt is of a lower priority. However, before the latched ISR completes its task or reenables interrupts, the ISR must clear the interrupt. For on-chip peripherals, the interrupt is cleared when the data register is accessed. *For GPIO-level interrupts, the interrupt signal must be removed before the ISR completes its task.* For GPIO-edge interrupts (single and dual), the interrupt is cleared by writing a 1 to the corresponding bit position in the data register. See the [Edge-Triggered Interrupts](#) section on page 62.

- **Note:** Care must be taken using a GPIO data register when it is configured for interrupts. For edge-interrupt modes (Modes 6 and 9) as discussed above, writing a 1 clears the interrupt. However, a 1 in the data register also conveys a particular configuration. For example, when the data register Px_DR is set first, followed by the Px_ALT2, Px_ALT1, and Px_DDR registers, then the configuration is performed correctly. Writing a 1 to the register later to clear interrupts does not change the configuration.

In Mode 9 operation, if the GPIO is already configured for Mode 9 and the trigger edge must be changed (from falling to rising or from rising to falling), the configuration must be changed to another mode, such as Mode 2, and then changed back to Mode 9. For example, enter Mode 2 by writing the registers in the sequence PxDR, Px_ALT2, Px_ALT1, Px_DDR. Next, change back to Mode 9 by writing the registers in the sequence PxDR, Px_ALT2, Px_ALT1, Px_DDR.

In Mode 8 operation, if the GPIO is configured for level-sensitive interrupts, a Write value to Px_DR after configuration must be the same Write value used when configuring the GPIO.

Chip Selects and Wait States

The eZ80F91 generates four Chip Selects for external devices. Each Chip Select can be programmed to access either memory space or I/O space. The Memory Chip Selects can be individually programmed on a 64KB boundary. The I/O Chip Selects can each choose a 256-byte section of I/O space. In addition, each Chip Select can be programmed for up to 7 wait states.

Memory and I/O Chip Selects

Each of the Chip Selects can be enabled for either the memory address space or the I/O address space, but not both. To select the memory address space for a particular Chip Select, CSX_IO (CSx_CTL[4]) must be reset to 0. To select the I/O address space for a particular Chip Select, CSX_IO must be set to 1. After RESET, the default is for all Chip Selects to be configured for the memory address space. For either the memory address space or the I/O address space, the individual Chip Selects must be enabled by setting CSX_EN (CSx_CTL[3]) to 1.

Memory Chip Select Operation

Operation of each of the Memory Chip Selects is controlled by three control registers. To enable a particular Memory Chip Select, the following conditions must be met:

- The Chip Select is enabled by setting CSx_EN to 1
- The Chip Select is configured for memory by clearing CSX_IO to 0
- The address is in the associated Chip Select range:
 $CSx_LBR[7:0] \leq ADDR[23:16] \leq CSx_UBR[7:0]$
- On-chip Flash is not configured for the same address space, because on-chip Flash is prioritized higher than all Memory Chip Selects
- On-chip RAM is not configured for the same address space, because on-chip RAM is prioritized higher than Flash and all Memory Chip Selects
- No higher priority (lower number) Chip Select meets the above conditions
- A memory access instruction must be executing

If all of the foregoing conditions are met to generate a Memory Chip Select, then the following actions occur:

- The appropriate Chip Select— $\overline{CS0}$, $\overline{CS1}$, $\overline{CS2}$, or $\overline{CS3}$ —is asserted (driven Low)

- $\overline{\text{MREQ}}$ is asserted (driven Low)
- Depending upon the instruction, either $\overline{\text{RD}}$ or $\overline{\text{WR}}$ is asserted (driven Low)

If the upper and lower bounds are set to the same value ($\text{CSx_UBR} = \text{CSx_LBR}$), then a particular Chip Select is valid for a single 64KB page.

www.DataSheet4U.com

Memory Chip Select Priority

A lower-numbered Chip Select is granted priority over a higher-numbered Chip Select. For example, if the address space of Chip Select 0 overlaps the Chip Select 1 address space, Chip Select 0 is active. If the address range programmed for any Chip Select signal overlaps with the address of internal memory, the internal memory is accorded higher priority. If the particular Chip Select(s) are configured with an address range that overlaps with an internal memory address, then when the internal memory is accessed, the Chip Select signal is not asserted.

Reset States

On RESET, Chip Select 0 is active for all addresses, because its Lower Bound register resets to 00h and its Upper Bound register resets to FFh. All of the other Chip Select Lower and Upper Bound registers reset to 00h.

Memory Chip Select Example

The use of Memory Chip Selects is demonstrated in Figure 6. The associated control register values are indicated in Table 17. In this example, all 4 Chip Selects are enabled and configured for memory addresses. Also, CS1 overlaps with CS0. Because CS0 is prioritized higher than CS1, CS1 is not active for much of its defined address space.

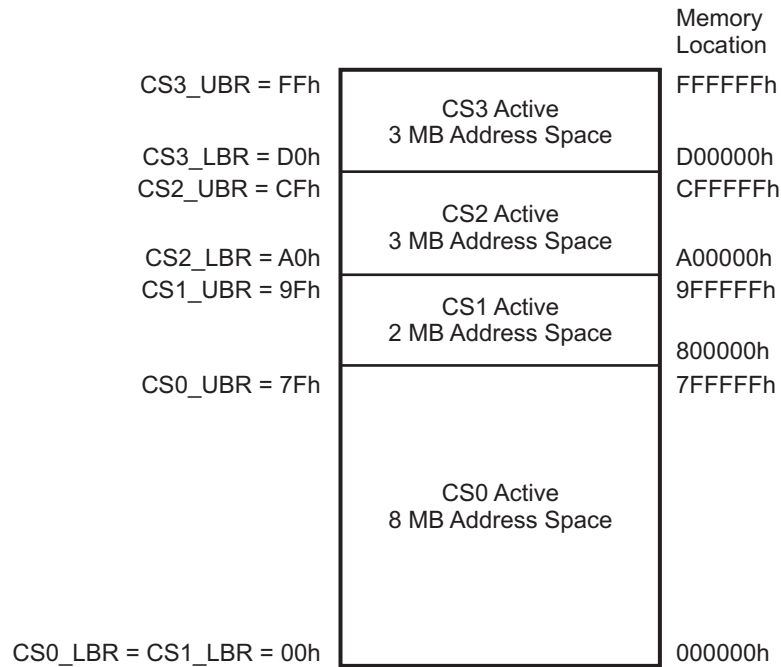

Figure 6. Example: Memory Chip Select

Table 17. Example: Register Values for Figure 6 Memory Chip Select

| Chip Select | CS _x _CTL[3] CS _x _EN | CS _x _CTL[4] CS _x _IO | CS _x _LBR | CS _x _UBR | Description |
|-------------|--|--|----------------------|----------------------|--|
| CS0 | 1 | 0 | 00h | 7Fh | CS0 is enabled as a Memory Chip Select. Valid addresses range from 000000h–7FFFFFFh. |
| CS1 | 1 | 0 | 00h | 9Fh | CS1 is enabled as a Memory Chip Select. Valid addresses range from 800000h–9FFFFFFh. |
| CS2 | 1 | 0 | A0h | CFh | CS2 is enabled as a Memory Chip Select. Valid addresses range from A00000h–CFFFFFFh. |
| CS3 | 1 | 0 | D0h | FFh | CS3 is enabled as a Memory Chip Select. Valid addresses range from D00000h–FFFFFFh. |

I/O Chip Select Operation

I/O Chip Selects can only be active when the CPU is performing I/O instructions. Because the I/O space is separate from the memory space in the eZ80F91 device, there can never be a conflict between I/O and memory addresses.

The eZ80F91 supports a 16-bit I/O address. The I/O Chip Select logic decodes the High byte of the I/O address, ADDR[15:8]. Because the upper byte of the address bus, ADDR[23:16], is ignored, the I/O devices can always be accessed from within either memory mode (ADL or Z80). The MBASE offset value used for setting the Z80 MEMORY mode page is also always ignored.

Four I/O Chip Selects are available with the eZ80F91 device. To generate a particular I/O Chip Select, the following conditions must be met:

- The Chip Select is enabled by setting CSx_EN to 1
- The Chip Select is configured for I/O by setting CSX_IO to 1
- An I/O Chip Select address match occurs—ADDR[15:8] = CSx_LBR[7:0]
- No higher-priority (lower-number) Chip Select meets the above conditions
- The I/O address is not within the on-chip peripheral address range 0080h–00FFh. On-chip peripheral registers assume priority for all addresses where:
 $0080h \leq ADDR[15:0] \leq 00FFh$
- An I/O instruction must be executing

If all of the foregoing conditions are met to generate an I/O Chip Select, then the following actions occur:

- The appropriate Chip Select— $\overline{CS0}$, $\overline{CS1}$, $\overline{CS2}$, or $\overline{CS3}$ —is asserted (driven Low)
- \overline{IORQ} is asserted (driven Low)
- Depending upon the instruction, either \overline{RD} or \overline{WR} is asserted (driven Low)

Wait States

For each of the Chip Selects, programmable wait states can be asserted to provide external devices with additional clock cycles to complete their Read or Write operations. The number of wait states for a particular Chip Select is controlled by the 3-bit field CSx_WAIT (CSx_CTL[7:5]). The wait states can be independently programmed to provide 0 to 7 wait states for each Chip Select. The wait states idle the CPU for the specified number of system clock cycles.

$\overline{\text{WAIT}}$ Input Signal

Similar to the programmable wait states, an external peripheral can drive the $\overline{\text{WAIT}}$ input pin to force the CPU to provide additional clock cycles to complete its Read or Write operation. Driving the $\overline{\text{WAIT}}$ pin Low stalls the CPU. The CPU resumes operation on the first rising edge of the internal system clock following deassertion of the $\overline{\text{WAIT}}$ pin.



Caution: If the $\overline{\text{WAIT}}$ pin is to be driven by an external device, the corresponding Chip Select for the device must be programmed to provide at least one wait state. Due to input sampling of the $\overline{\text{WAIT}}$ input pin (shown in Figure 7), one programmable wait state is required to allow the external peripheral sufficient time to assert the $\overline{\text{WAIT}}$ pin. It is recommended that the corresponding Chip Select for the external device be programmed to provide the maximum number of wait states (seven).

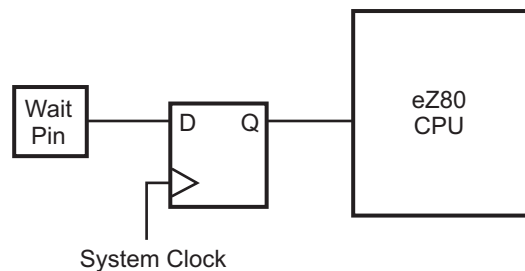

Figure 7. Wait Input Sampling Block Diagram

An example of wait state operation is illustrated in Figure 8. In this example, the Chip Select is configured to provide a single wait state. The external peripheral being accessed drives the $\overline{\text{WAIT}}$ pin Low to request assertion of an additional wait state. If the $\overline{\text{WAIT}}$ pin is asserted for additional system clock cycles, wait states are added until the $\overline{\text{WAIT}}$ pin is deasserted (active High).

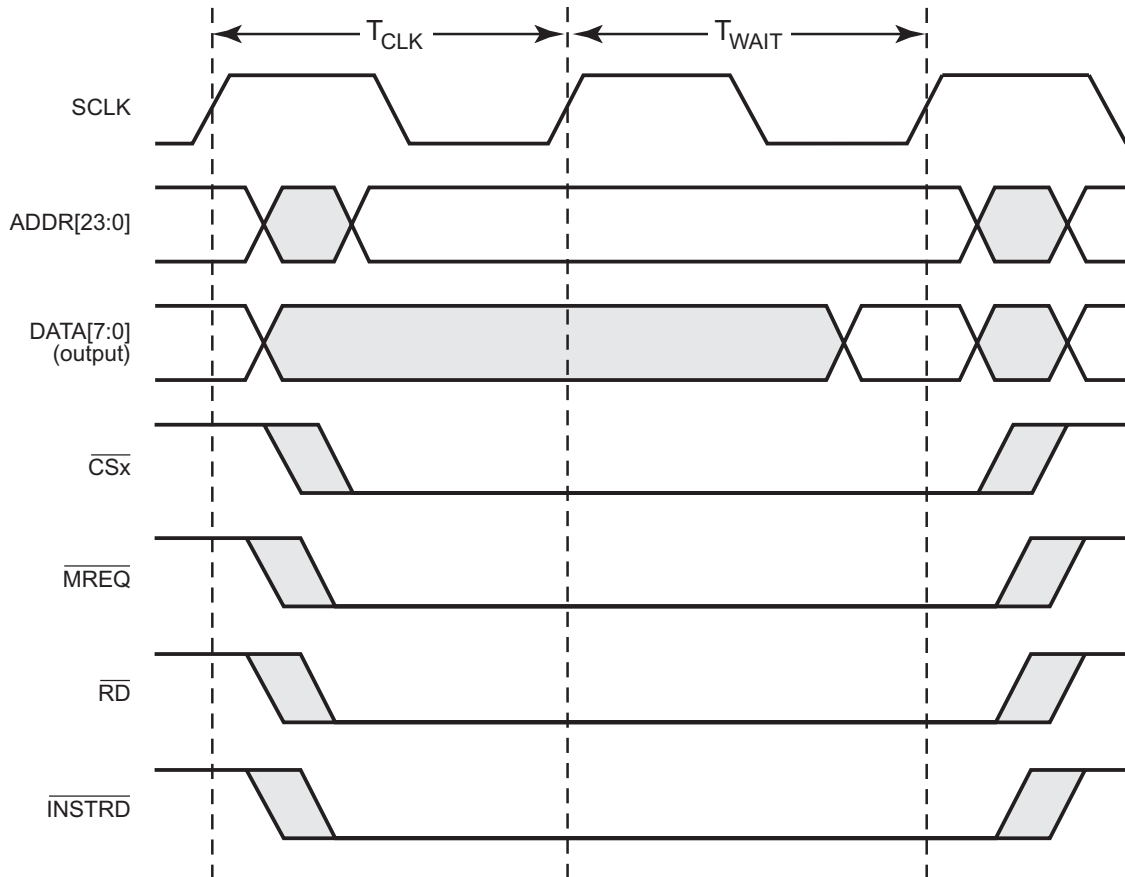

Figure 8. Example: Wait State Read Operation

Chip Selects During Bus Request/Bus Acknowledge Cycles

When the CPU relinquishes the address bus to an external peripheral in response to an external bus request (BUSREQ), it drives the bus acknowledge pin (BUSACK) Low. The external peripheral can then drive the address bus (and data bus). The CPU continues to generate Chip Select signals in response to the address on the bus. External devices cannot access the internal registers of the eZ80F91.

Bus Mode Controller

The bus mode controller allows the address and data bus timing and signal formats of the eZ80F91 to be configured to connect seamlessly with external eZ80[®]-, Z80[™]-, Intel[™]-, or Motorola-compatible devices. Bus modes for each of the chip selects can be configured independently using the Chip Select Bus Mode



Control Registers. The number of CPU system clock cycles per bus mode state is also independently programmable. For Intel bus mode, multiplexed address and data can be selected, in which the lower byte of the address and the data byte both use the data bus, DATA[7:0]. Each of the bus modes is explained in more detail in the following sections.

eZ80 Bus Mode

Chip selects configured for eZ80 bus mode do not modify the bus signals from the CPU. The timing diagrams for external Memory and I/O Read and Write operations are shown in the [AC Characteristics](#) section on page 348. The default mode for each chip select is eZ80 mode.

Z80 Bus Mode

Chip selects configured for Z80 mode modify the eZ80[®] bus signals to match the Z80 microprocessor address and data bus interface signal format and timing. During Read operations, the Z80 Bus mode employs three states—T1, T2, and T3—as described in Table 18.

Table 18. Z80 Bus Mode Read States

| | |
|----------|---|
| STATE T1 | The Read cycle begins in State T1. The CPU drives the address onto the address bus and the associated Chip Select signal is asserted. |
| STATE T2 | During State T2, the \overline{RD} signal is asserted. Depending upon the instruction, either the MREQ or IORQ signal is asserted. If the external WAIT pin is driven Low at least one CPU system clock cycle prior to the end of State T2, additional wait states (T_{WAIT}) are asserted until the WAIT pin is driven High. |
| STATE T3 | During State T3, no bus signals are altered. The data is latched by the eZ80F91 at the rising edge of the CPU system clock at the end of State T3. |

During Write operations, Z80 Bus mode employs 3 states—T1, T2, and T3—as described in Table 19.

Table 19. Z80 Bus Mode Write States

| | |
|----------|---|
| STATE T1 | The Write cycle begins in State T1. The CPU drives the address onto the address bus, and the associated Chip Select signal is asserted. |
| STATE T2 | During State T2, the \overline{WR} signal is asserted. Depending upon the instruction, either the MREQ or IORQ signal is asserted. If the external WAIT pin is driven Low at least one CPU system clock cycle prior to the end of State T2, additional wait states (T_{WAIT}) are asserted until the WAIT pin is driven High. |
| STATE T3 | During State T3, no bus signals are altered. |



Z80 bus mode Read and Write timing is illustrated in Figures 9 and 10 . The Z80 bus mode states can be configured for 1 to 15 CPU system clock cycles. In the figures, each Z80 bus mode state is two CPU system clock cycles in duration. Figures 9 and 10 also illustrate the assertion of 1 wait state (T_{WAIT}) by the external peripheral during each Z80 bus mode cycle.

www.DataSheet4U.com

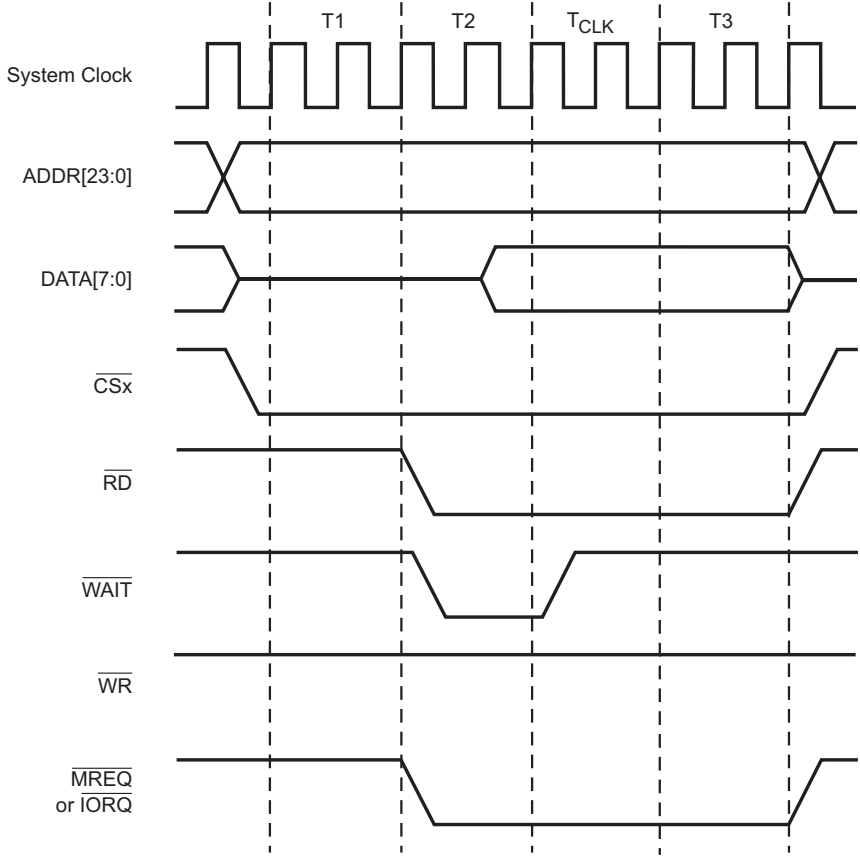

Figure 9. Example: Z80 Bus Mode Read Timing

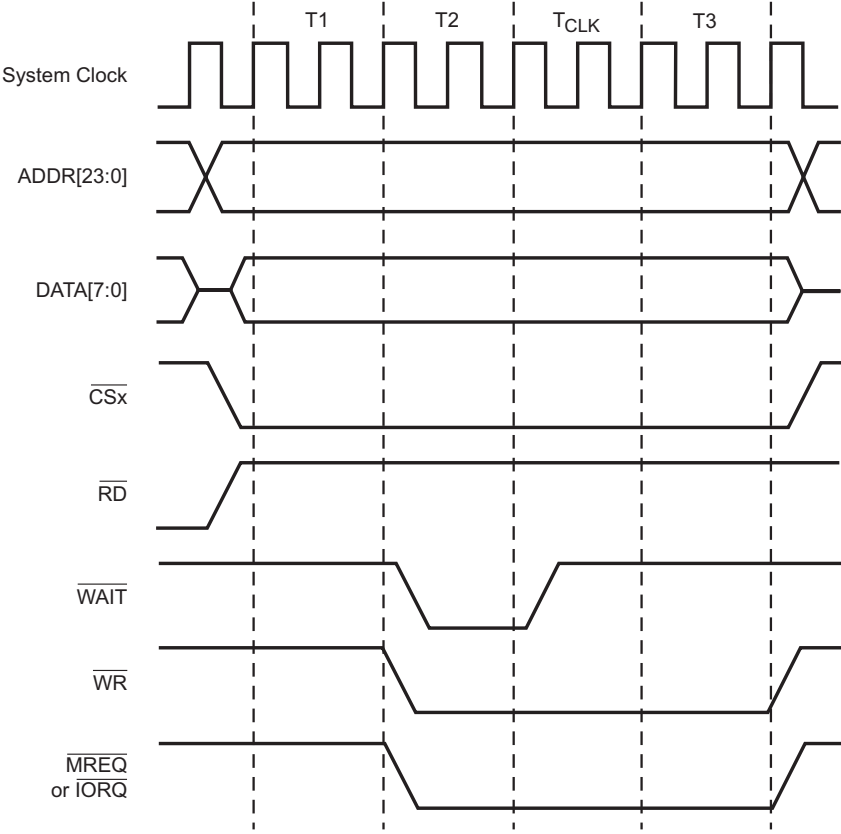

Figure 10. Example: Z80 Bus Mode Write Timing

Intel Bus Mode

Chip selects configured for Intel bus mode modify the CPU bus signals to duplicate a four-state memory transfer similar to that found on Intel-style microcontrollers. The bus signals and eZ80F91 pins are mapped as illustrated in Figure 11. In Intel bus mode, the user can select either multiplexed or nonmultiplexed address and data buses. In nonmultiplexed operation, the address and data buses are separate. In multiplexed operation, the lower byte of the address, ADDR[7:0], also appears on the data bus, DATA[7:0], during State T1 of the Intel bus mode cycle.

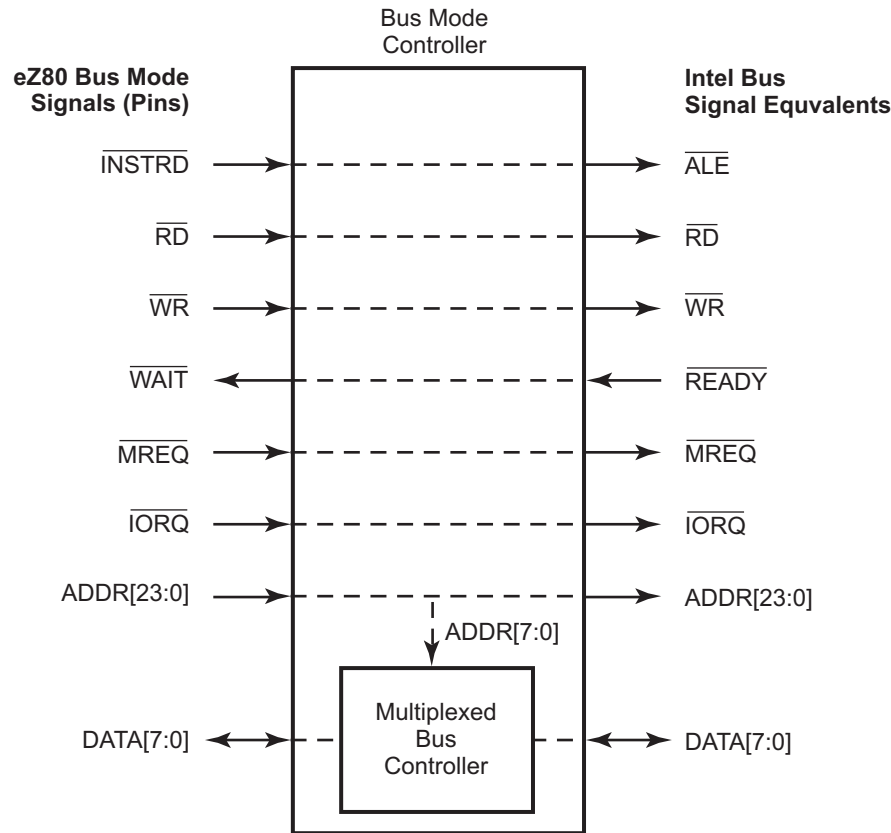

Figure 11. Intel Bus Mode Signal and Pin Mapping

Intel Bus Mode—Separate Address and Data Buses

During Read operations with separate address and data buses, the Intel bus mode employs 4 states—T1, T2, T3, and T4—as described in Table 20.

Table 20. Intel Bus Mode Read States—Separate Address and Data Buses

| | |
|----------|---|
| STATE T1 | The Read cycle begins in State T1. The CPU drives the address onto the address bus and the associated Chip Select signal is asserted. The CPU drives the ALE signal High at the beginning of T1. During the middle of T1, the CPU drives ALE Low to facilitate the latching of the address. |
| STATE T2 | During State T2, the CPU asserts the $\overline{\text{RD}}$ signal. Depending on the instruction, either the $\overline{\text{MREQ}}$ or $\overline{\text{IORQ}}$ signal is asserted. |



Table 20. Intel Bus Mode Read States—Separate Address and Data Buses (Continued)

| | |
|----------|--|
| STATE T3 | During State T3, no bus signals are altered. If the external READY (WAIT) pin is driven Low at least one CPU system clock cycle prior to the beginning of State T3, additional wait states (T_{WAIT}) are asserted until the READY pin is driven High. |
| STATE T4 | The CPU latches the Read data at the beginning of State T4. The CPU deasserts the RD signal and completes the Intel bus mode cycle. |

During Write operations with separate address and data buses, the Intel bus mode employs 4 states—T1, T2, T3, and T4—as described in Table 21.

Table 21. Intel Bus Mode Write States—Separate Address and Data Buses

| | |
|----------|---|
| STATE T1 | The Write cycle begins in State T1. The CPU drives the address onto the address bus, the associated Chip Select signal is asserted, and the data is driven onto the data bus. The CPU drives the ALE signal High at the beginning of T1. During the middle of T1, the CPU drives ALE Low to facilitate the latching of the address. |
| STATE T2 | During State T2, the CPU asserts the WR signal. Depending on the instruction, either the MREQ or IORQ signal is asserted. |
| STATE T3 | During State T3, no bus signals are altered. If the external READY (WAIT) pin is driven Low at least one CPU system clock cycle prior to the beginning of State T3, additional wait states (T_{WAIT}) are asserted until the READY pin is driven High. |
| STATE T4 | The CPU deasserts the WR signal at the beginning of State T4. The CPU holds the data and address buses through the end of T4. The bus cycle is completed at the end of T4. |

Intel™ bus mode timing is illustrated for a Read operation in Figure 12 and for a Write operation in Figure 13. If the READY signal (external WAIT pin) is driven Low prior to the beginning of State T3, additional wait states (T_{WAIT}) are asserted until the READY signal is driven High. The Intel bus mode states can be configured for 2 to 15 CPU system clock cycles. In the figures, each Intel™ bus mode state is 2 CPU system clock cycles in duration. Figures 12 and 13 also illustrate the assertion of one wait state (T_{WAIT}) by the selected peripheral.

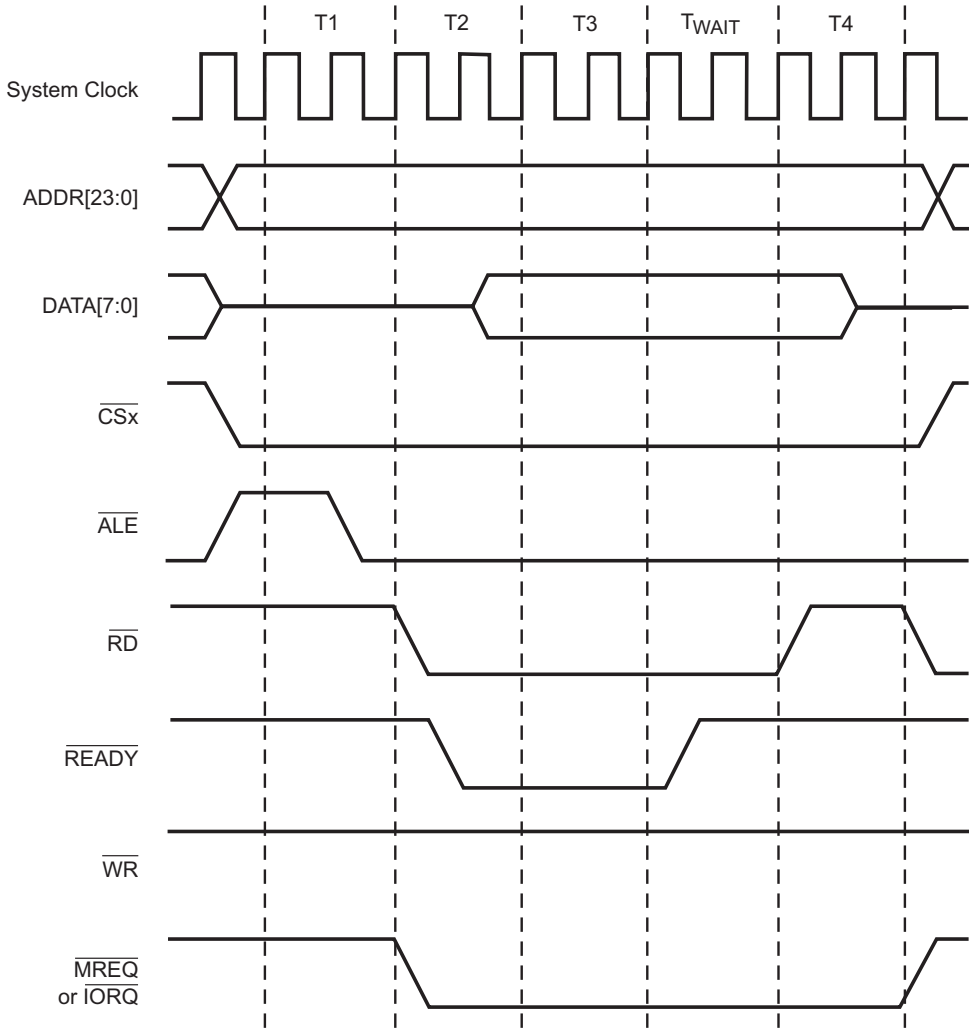

Figure 12. Example: Intel Bus Mode Read Timing—Separate Address and Data Buses

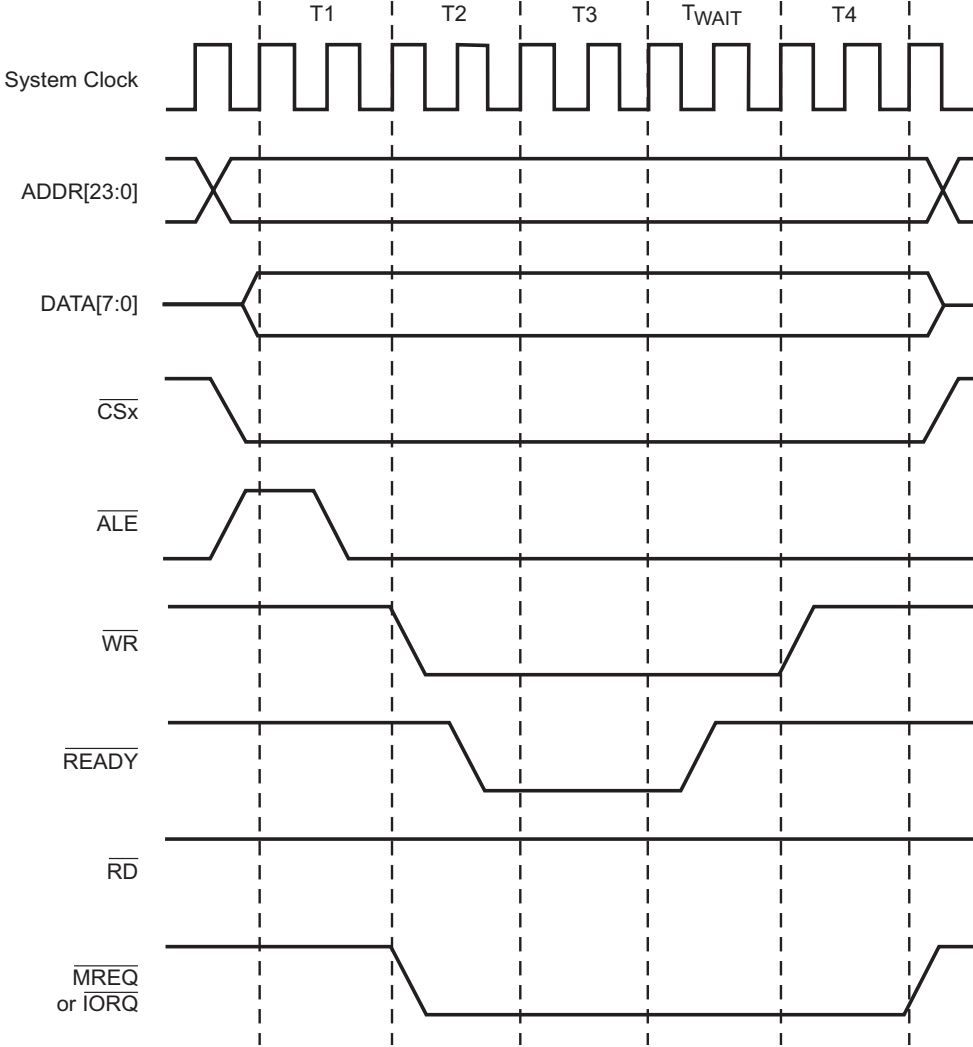

Figure 13. Example: Intel Bus Mode Write Timing—Separate Address and Data Buses



Intel™ Bus Mode—Multiplexed Address and Data Bus

During Read operations with multiplexed address and data, the Intel™ bus mode employs 4 states—T1, T2, T3, and T4—as described in Table 22.

Table 22. Intel™ Bus Mode Read States—Multiplexed Address and Data Bus

| | |
|----------|--|
| STATE T1 | The Read cycle begins in State T1. The CPU drives the address onto the DATA bus and the associated Chip Select signal is asserted. The CPU drives the ALE signal High at the beginning of T1. During the middle of T1, the CPU drives ALE Low to facilitate the latching of the address. |
| STATE T2 | During State T2, the CPU removes the address from the DATA bus and asserts the RD signal. Depending upon the instruction, either the MREQ or IORQ signal is asserted. |
| STATE T3 | During State T3, no bus signals are altered. If the external READY (WAIT) pin is driven Low at least one CPU system clock cycle prior to the beginning of State T3, additional wait states (T_{WAIT}) are asserted until the READY pin is driven High. |
| STATE T4 | The CPU latches the Read data at the beginning of State T4. The CPU deasserts the RD signal and completes the Intel™ bus mode cycle. |

During Write operations with multiplexed address and data, the Intel™ bus mode employs 4 states—T1, T2, T3, and T4—as described in Table 23.

Table 23. Intel™ Bus Mode Write States—Multiplexed Address and Data Bus

| | |
|----------|--|
| STATE T1 | The Write cycle begins in State T1. The CPU drives the address onto the DATA bus and drives the ALE signal High at the beginning of T1. During the middle of T1, the CPU drives ALE Low to facilitate the latching of the address. |
| STATE T2 | During State T2, the CPU removes the address from the DATA bus and drives the Write data onto the DATA bus. The WR signal is asserted to indicate a Write operation. |
| STATE T3 | During State T3, no bus signals are altered. If the external READY (WAIT) pin is driven Low at least one CPU system clock cycle prior to the beginning of State T3, additional wait states (T_{WAIT}) are asserted until the READY pin is driven High. |
| STATE T4 | The CPU deasserts the Write signal at the beginning of T4 identifying the end of the Write operation. The CPU holds the data and address buses through the end of T4. The bus cycle is completed at the end of T4. |



Signal timing for Intel™ bus mode with multiplexed address and data is illustrated for a Read operation in Figure 14 and for a Write operation in Figure 15. In these figures, each Intel™ bus mode state is 2 CPU system clock cycles in duration. Figures 14 and 15 also illustrate the assertion of one wait state (T_{WAIT}) by the selected peripheral.

www.DataSheet4U.com

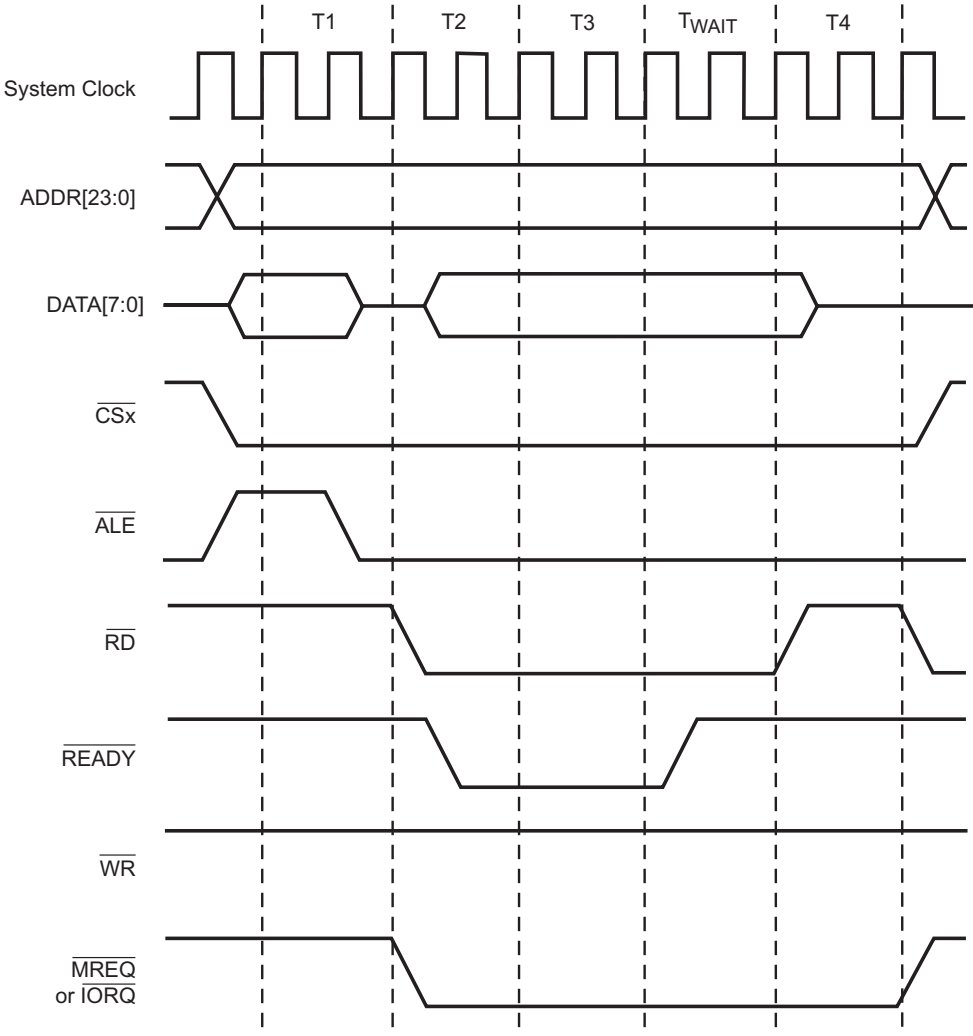

Figure 14. Example: Intel™ Bus Mode Read Timing—Multiplexed Address and Data Bus

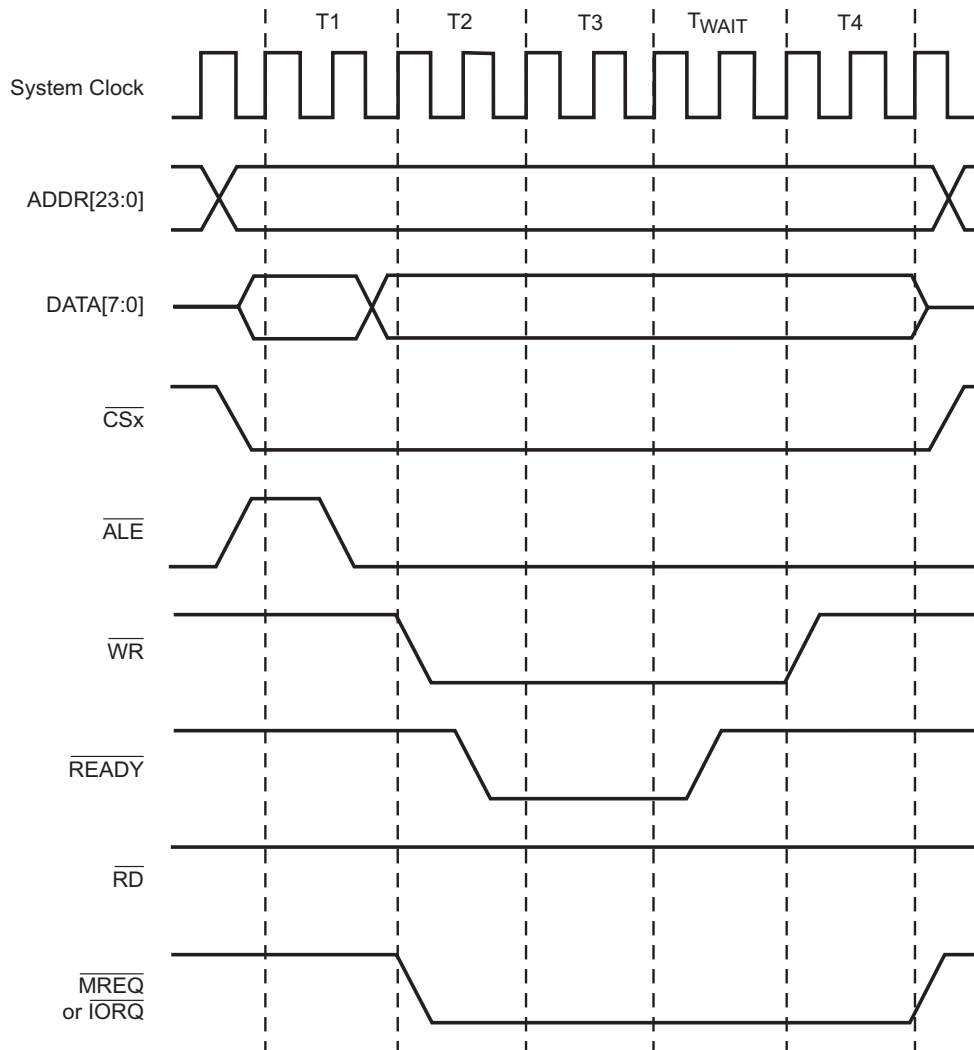

Figure 15. Example: Intel™ Bus Mode Write Timing—Multiplexed Address and Data Bus

Motorola Bus Mode

Chip selects configured for Motorola bus mode modify the CPU bus signals to duplicate an eight-state memory transfer similar to that found on Motorola-style microcontrollers. The bus signals (and eZ80F91 I/O pins) are mapped as illustrated in Figure 16.

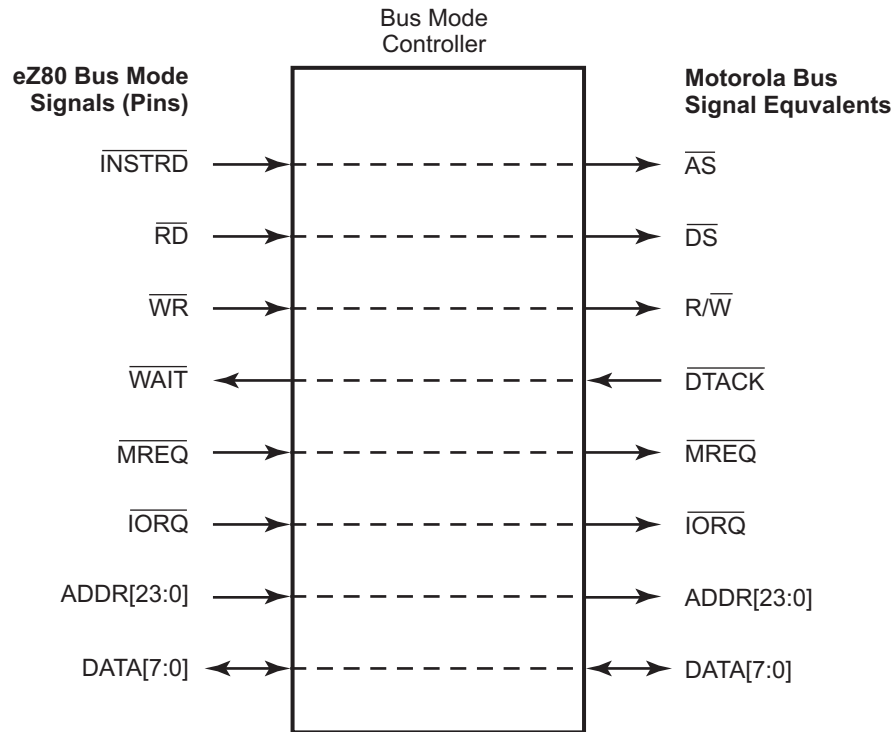

Figure 16. Motorola Bus Mode Signal and Pin Mapping

During Write operations, the Motorola bus mode employs 8 states—S0, S1, S2, S3, S4, S5, S6, and S7—as described in Table 24.

Table 24. Motorola Bus Mode Read States

| | |
|----------|--|
| STATE S0 | The Read cycle starts in state S0. The CPU drives $\overline{R/W}$ High to identify a Read cycle. |
| STATE S1 | Entering state S1, the CPU drives a valid address on the address bus, ADDR[23:0]. |
| STATE S2 | On the rising edge of state S2, the CPU asserts \overline{AS} and \overline{DS} . |
| STATE S3 | During state S3, no bus signals are altered. |
| STATE S4 | During state S4, the CPU waits for a cycle termination signal \overline{DTACK} (\overline{WAIT}), a peripheral signal. If the termination signal is not asserted at least one full CPU clock period <u>prior to</u> the rising clock edge at the end of S4, the CPU inserts \overline{WAIT} ($T_{\overline{WAIT}}$) states until \overline{DTACK} is asserted. Each wait state is a full bus mode cycle. |
| STATE S5 | During state S5, no bus signals are altered. |



Table 24. Motorola Bus Mode Read States (Continued)

| | |
|----------|---|
| STATE S6 | During state S6, data from the external peripheral device is driven onto the data bus. |
| STATE S7 | On the rising edge of the clock entering state <u>S7</u> , the <u>CPU</u> latches data from the <u>addressed</u> peripheral device and deasserts AS and DS. The peripheral device deasserts DTACK at this time. |

www.DataSheet4U.com

The eight states for a Write operation in Motorola bus mode are described in Table 25.

Table 25. Motorola Bus Mode WRITE States

| | |
|----------|--|
| STATE S0 | The <u>Write</u> cycle starts in S0. The CPU drives $\overline{R/W}$ High (if a preceding Write cycle leaves $\overline{R/W}$ Low). |
| STATE S1 | Entering S1, the CPU drives a valid address on the address bus. |
| STATE S2 | On the rising edge of S2, the CPU asserts \overline{AS} and drives $\overline{R/W}$ Low. |
| STATE S3 | During S3, the data bus is driven out of the high-impedance state as the data to be written is placed on the bus. |
| STATE S4 | <u>At the rising edge</u> of S4, the CPU asserts \overline{DS} . The CPU waits for a cycle termination signal DTACK (WAIT). If the termination signal is not asserted at least one full CPU clock period <u>prior to</u> the rising clock edge at the end of S4, the CPU inserts WAIT (T_{WAIT}) states until DTACK is asserted. Each wait state is a full bus mode cycle. |
| STATE S5 | During S5, no bus signals are altered. |
| STATE S6 | During S6, no bus signals are altered. |
| STATE S7 | Upon entering <u>S7</u> , the CPU deasserts \overline{AS} and \overline{DS} . As the <u>clock</u> rises at the end of S7, the CPU drives $\overline{R/W}$ High. The peripheral device deasserts DTACK at this time. |

Signal timing for Motorola bus mode is illustrated for a Read operation in Figure 17 and for a Write operation in Figure 18. In these two figures, each Motorola bus mode state is 2 CPU system clock cycles in duration.

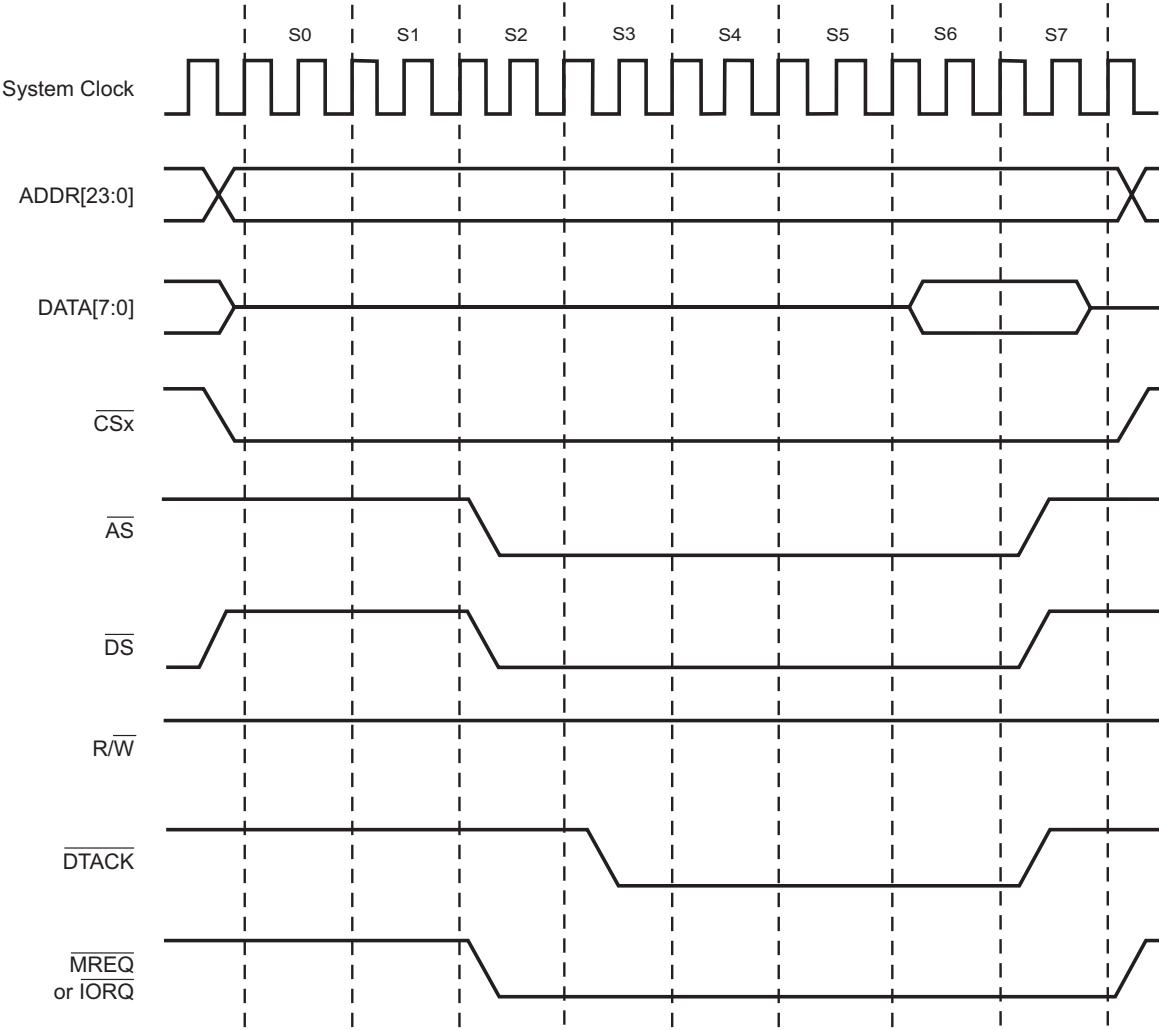

Figure 17. Motorola Bus Mode Read Timing Example

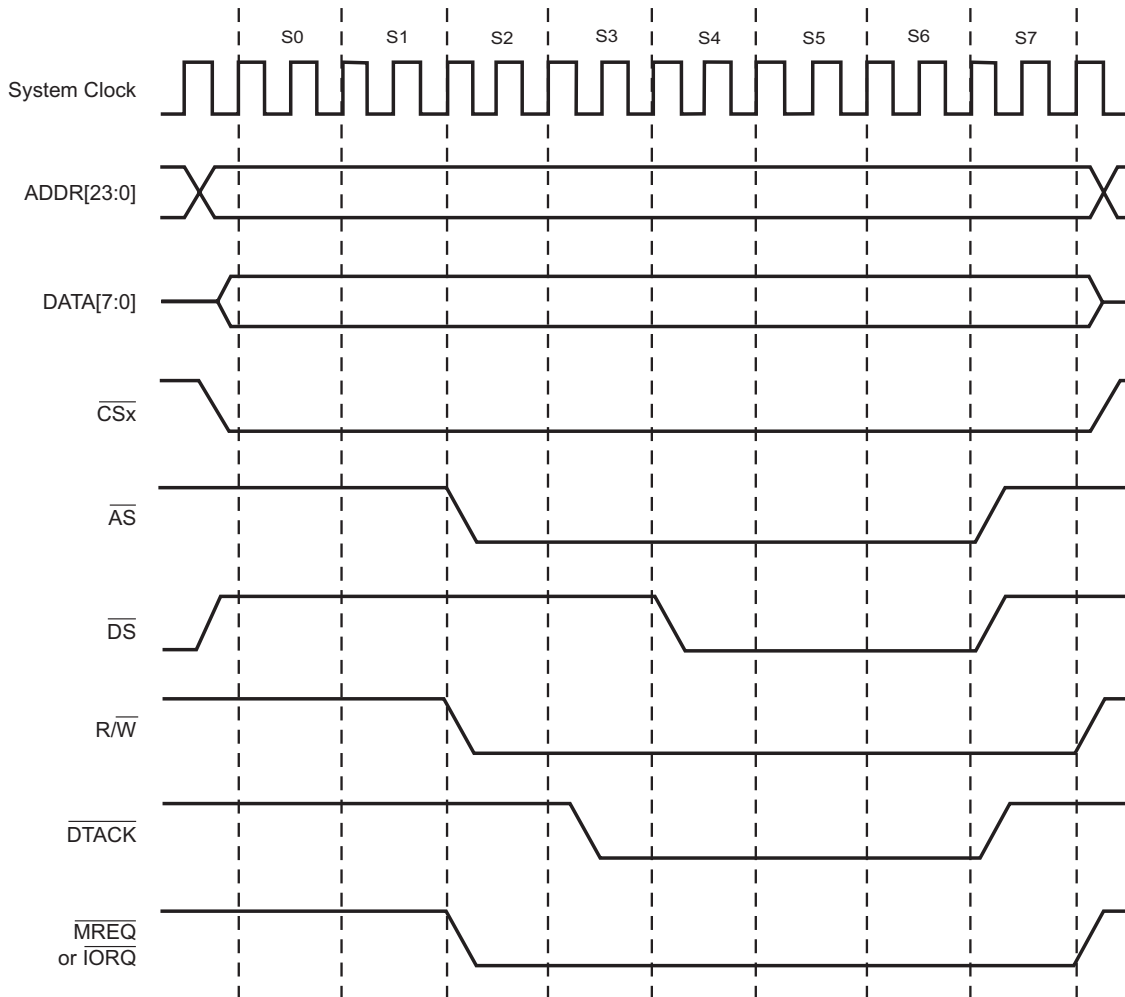

Figure 18. Motorola Bus Mode Write Timing Example

Switching Between Bus Modes

When switching bus modes between Intel™ to Motorola, Motorola to Intel™, eZ80 to Motorola, or eZ80 to Intel™, there is one extra SCLK cycle added to the bus access. An extra clock cycle is not required for repeated access in any of the bus modes (for example Intel™ to Intel™). An extra clock cycle is not required for Intel™ (or Motorola) to eZ80 bus mode (under normal operation). The extra clock cycle is not shown in the timing examples. Due to the asynchronous nature of these bus protocols, the extra delay does not impact peripheral communication.



Chip Select Registers

Chip Select x Lower Bound Register

For Memory Chip Selects, the Chip Select x Lower Bound register, detailed in Table 26, defines the lower bound of the address range for which the corresponding Memory Chip Select (if enabled) can be active. For I/O Chip Selects, this register defines the address to which ADDR[15:8] is compared to generate an I/O Chip Select. All Chip Select lower bound registers reset to 00h.

Table 26. Chip Select x Lower Bound Register
(CS0_LBR = 00A8h, CS1_LBR = 00ABh, CS2_LBR = 00AEh, CS3_LBR = 00B1h)

| Bit | 7 | 6 | 5 | 4 | 3 | 2 | 1 | 0 |
|---------------|-----|-----|-----|-----|-----|-----|-----|-----|
| CS0_LBR Reset | 0 | 0 | 0 | 0 | 0 | 0 | 0 | 0 |
| CS1_LBR Reset | 0 | 0 | 0 | 0 | 0 | 0 | 0 | 0 |
| CS2_LBR Reset | 0 | 0 | 0 | 0 | 0 | 0 | 0 | 0 |
| CS3_LBR Reset | 0 | 0 | 0 | 0 | 0 | 0 | 0 | 0 |
| CPU Access | R/W | R/W | R/W | R/W | R/W | R/W | R/W | R/W |

Note: R/W = Read/Write.

| Bit Position | Value | Description |
|------------------|-------------|--|
| [7:0] CSX_LBR | 00h– FFh | <p>For Memory Chip Selects (CSx_IO = 0) This byte specifies the lower bound of the Chip Select address range. The upper byte of the address bus, ADDR[23:16], is compared to the values contained in these registers for determining whether a Memory Chip Select signal should be generated.</p> <p>For I/O Chip Selects (CSx_IO = 1) This byte specifies the Chip Select address value. ADDR[15:8] is compared to the values contained in these registers for determining whether an I/O Chip Select signal should be generated.</p> |



Chip Select x Upper Bound Register

For Memory Chip Selects, the Chip Select x Upper Bound registers, detailed in Table 27, defines the upper bound of the address range for which the corresponding Chip Select (if enabled) can be active. For I/O Chip Selects, this register produces no effect. The reset state for the Chip Select 0 Upper Bound register is FFh, while the reset state for the other Chip Select upper bound registers is 00h.

Table 27. Chip Select x Upper Bound Register
(CS0_UBR = 00A9h, CS1_UBR = 00ACh, CS2_UBR = 00AFh, CS3_UBR = 00B2h)

| Bit | 7 | 6 | 5 | 4 | 3 | 2 | 1 | 0 |
|----------------------|-----|-----|-----|-----|-----|-----|-----|-----|
| CS0_UBR Reset | 1 | 1 | 1 | 1 | 1 | 1 | 1 | 1 |
| CS1_UBR Reset | 0 | 0 | 0 | 0 | 0 | 0 | 0 | 0 |
| CS2_UBR Reset | 0 | 0 | 0 | 0 | 0 | 0 | 0 | 0 |
| CS3_UBR Reset | 0 | 0 | 0 | 0 | 0 | 0 | 0 | 0 |
| CPU Access | R/W | R/W | R/W | R/W | R/W | R/W | R/W | R/W |

Note: R/W = Read/Write.

| Bit Position | Value | Description |
|------------------|-------------|--|
| [7:0] CSX_UBR | 00h– FFh | <p>For Memory Chip Selects (CSX_IO = 0) This byte specifies the upper bound of the Chip Select address range. The upper byte of the address bus, ADDR[23:16], is compared to the values contained in these registers for determining whether a Chip Select signal should be generated.</p> <hr/> <p>For I/O Chip Selects (CSx_IO = 1) No effect.</p> |



Chip Select x Control Register

The Chip Select x Control register, detailed in Table 28, enables the Chip Selects, specifies the type of Chip Select, and sets the number of wait states. The reset state for the Chip Select 0 Control register is $E8h$, while the reset state for the 3 other Chip Select control registers is $00h$.

Table 28. Chip Select x Control Register
(CS0_CTL = 00AAh, CS1_CTL = 00ADh, CS2_CTL = 00B0h, CS3_CTL = 00B3h)

| Bit | 7 | 6 | 5 | 4 | 3 | 2 | 1 | 0 |
|---------------|-----|-----|-----|-----|-----|---|---|---|
| CS0_CTL Reset | 1 | 1 | 1 | 0 | 1 | 0 | 0 | 0 |
| CS1_CTL Reset | 0 | 0 | 0 | 0 | 0 | 0 | 0 | 0 |
| CS2_CTL Reset | 0 | 0 | 0 | 0 | 0 | 0 | 0 | 0 |
| CS3_CTL Reset | 0 | 0 | 0 | 0 | 0 | 0 | 0 | 0 |
| CPU Access | R/W | R/W | R/W | R/W | R/W | R | R | R |

Note: R/W = Read/Write; R = Read Only.

| Bit Position | Value | Description |
|-------------------|-------|---|
| [7:5] CSX_WAIT | 000 | 0 wait states are asserted when this Chip Select is active. |
| | 001 | 1 wait state is asserted when this Chip Select is active. |
| | 010 | 2 wait states are asserted when this Chip Select is active. |
| | 011 | 3 wait states are asserted when this Chip Select is active. |
| | 100 | 4 wait states are asserted when this Chip Select is active. |
| | 101 | 5 wait states are asserted when this Chip Select is active. |
| | 110 | 6 wait states are asserted when this Chip Select is active. |
| | 111 | 7 wait states are asserted when this Chip Select is active. |
| 4 CSX_IO | 0 | Chip Select is configured as a Memory Chip Select. |
| | 1 | Chip Select is configured as an I/O Chip Select. |
| 3 CSX_EN | 0 | Chip Select is disabled. |
| | 1 | Chip Select is enabled. |
| [2:0] | 000 | Reserved. |



Chip Select x Bus Mode Control Register

The Chip Select Bus Mode register, detailed in Table 29, configures the Chip Select for eZ80, Z80, Intel™, or Motorola bus modes. Changing the bus mode allows the eZ80F91 device to interface to peripherals based on the Z80-, Intel™-, or Motorola-style asynchronous bus interfaces. When a bus mode other than eZ80 is programmed for a particular Chip Select, the CSx_WAIT setting in that Chip Select Control Register is ignored.

Table 29. Chip Select x Bus Mode Control Register
(CS0_BMC = 00F0h, CS1_BMC = 00F1h, CS2_BMC = 00F2h, CS3_BMC = 00F3h)

| Bit | 7 | 6 | 5 | 4 | 3 | 2 | 1 | 0 |
|----------------------|-----|-----|-----|---|-----|-----|-----|-----|
| CS0_BMC Reset | 0 | 0 | 0 | 0 | 0 | 0 | 1 | 0 |
| CS1_BMC Reset | 0 | 0 | 0 | 0 | 0 | 0 | 1 | 0 |
| CS2_BMC Reset | 0 | 0 | 0 | 0 | 0 | 0 | 1 | 0 |
| CS3_BMC Reset | 0 | 0 | 0 | 0 | 0 | 0 | 1 | 0 |
| CPU Access | R/W | R/W | R/W | R | R/W | R/W | R/W | R/W |

Note: R/W = Read/Write; R = Read Only.

| Bit Position | Value | Description |
|-------------------|-------|---|
| [7:6] BUS_MODE | 00 | eZ80 bus mode. |
| | 01 | Z80 bus mode. |
| | 10 | Intel™ bus mode. |
| | 11 | Motorola bus mode. |
| 5 AD_MUX | 0 | Separate address and data. |
| | 1 | Multiplexed address and data—appears on data bus DATA[7:0]. |
| 4 | 0 | Reserved. |



| Bit Position | Value | Description |
|--------------------|-------|--|
| [3:0] BUS_CYCLE | 0000 | Not valid. |
| | 0001 | Each bus mode state is 1 eZ80 [®] clock cycle in duration. ^{1, 2, 3} |
| | 0010 | Each bus mode state is 2 eZ80 [®] clock cycles in duration. |
| | 0011 | Each bus mode state is 3 eZ80 [®] clock cycles in duration. |
| | 0100 | Each bus mode state is 4 eZ80 [®] clock cycles in duration. |
| | 0101 | Each bus mode state is 5 eZ80 [®] clock cycles in duration. |
| | 0110 | Each bus mode state is 6 eZ80 [®] clock cycles in duration. |
| | 0111 | Each bus mode state is 7 eZ80 [®] clock cycles in duration. |
| | 1000 | Each bus mode state is 8 eZ80 [®] clock cycles in duration. |
| | 1001 | Each bus mode state is 9 eZ80 [®] clock cycles in duration. |
| | 1010 | Each bus mode state is 10 eZ80 [®] clock cycles in duration. |
| | 1011 | Each bus mode state is 11 eZ80 [®] clock cycles in duration. |
| | 1100 | Each bus mode state is 12 eZ80 [®] clock cycles in duration. |
| | 1101 | Each bus mode state is 13 eZ80 [®] clock cycles in duration. |
| | 1110 | Each bus mode state is 14 eZ80 [®] clock cycles in duration. |
| | 1111 | Each bus mode state is 15 eZ80 [®] clock cycles in duration. |

Notes:

1. Setting the BUS_CYCLE to 1 in Intel bus mode causes the ALE pin to not function properly.
2. Use of the external WAIT input pin in Z80 Mode requires that BUS_CYCLE is set to a value greater than 1.
3. BUS_CYCLE produces no effect in eZ80 mode.



Bus Arbiter

The Bus Arbiter within the eZ80F91 allows external bus masters to gain control of the CPU memory interface bus. During normal operation, the eZ80F91 device is the bus master. External devices can request master use of the bus by asserting the BUSREQ pin. The Bus Arbiter forces the CPU to release the bus after completing the current instruction. When the CPU releases the bus, the Bus Arbiter asserts the BUSACK pin to notify the external device that it can master the bus. When an external device assumes control of the memory interface bus, the bus acknowledge cycle is complete. Table 30 shows the status of the pins on the eZ80F91 device during bus acknowledge cycles.

During a bus acknowledge cycle, the bus interface pins of the eZ80F91 device can be used by an external bus master to control the memory and I/O Chip Selects.

Table 30. eZ80F91 Pin Status During Bus Acknowledge Cycles

| Pin Symbol | Signal Direction | Description |
|---------------|------------------|---|
| ADDR23..ADDR0 | Input | Allows external bus master to utilize the Chip Select logic of the eZ80F91. |
| CS0 | Output | Normal operation. |
| CS1 | Output | Normal operation. |
| CS2 | Output | Normal operation. |
| CS3 | Output | Normal operation. |
| DATA7..0 | Tristate | Allows external bus master to communicate with external peripherals. |
| IORQ | Input | Allows external bus master to utilize the Chip Select logic of the eZ80F91. |
| MREQ | Input | Allows external bus master to utilize the Chip Select logic of the eZ80F91. |
| RD | Tristate | Allows external bus master to communicate with external peripherals. |
| WR | Tristate | Allows external bus master to communicate with external peripherals. |
| INSTRD | Tristate | Allows external bus master to communicate with external peripherals. |

Normal bus operation of the eZ80F91 device using $\overline{CS0}$ to communicate to an external peripheral is shown in Figure 19. Figure 20 shows an external bus master communicating with an external peripheral during bus acknowledge cycles.

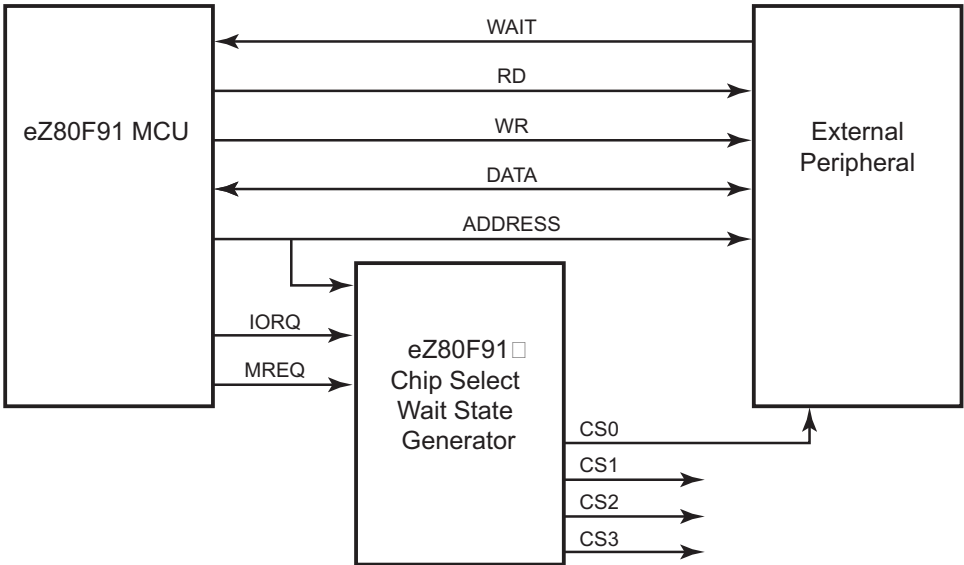

Figure 19. Memory Interface Bus Operation During CPU Bus Cycles, Normal Operation

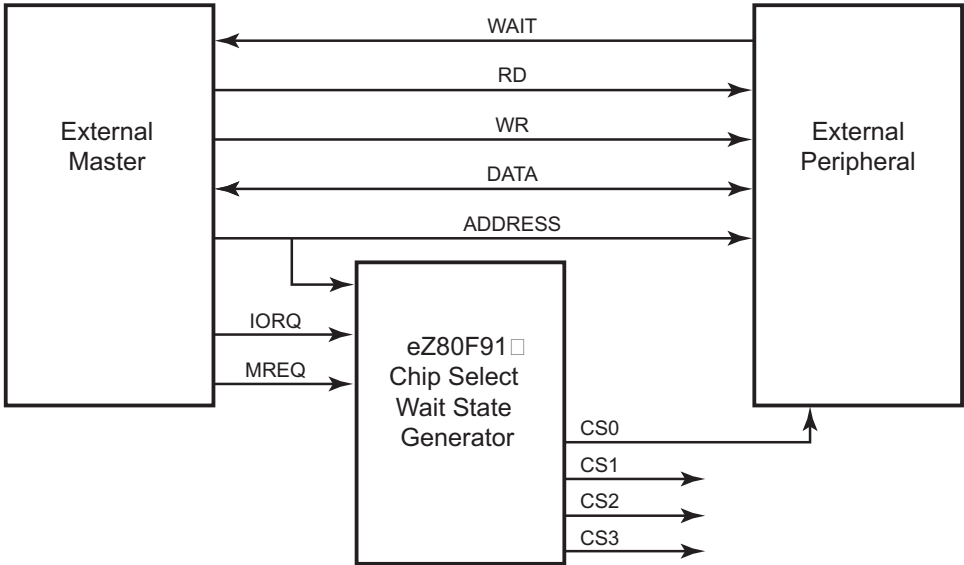

Figure 20. Memory Interface Bus Operation During Bus Acknowledge Cycles



During bus acknowledge cycles, the Memory and I/O Chip Select logic is controlled by the external address bus and external IORQ and MREQ signals.

The following Chip Select features are not available during bus acknowledge cycles:

1. The Chip Select logic does not insert wait states during bus acknowledge cycles regardless of the WAIT configuration for the decoded Chip Select.
2. The bus mode controller does not function during bus acknowledge cycles.
3. Internal registers and memory addresses in the eZ80F91 device are not accessible during bus acknowledge cycles.

Random Access Memory

The eZ80F91 device features 8KB (8192 bytes) of single-port data Random Access Memory (RAM) for general-purpose use and 8KB of RAM for the Ethernet MAC. RAM can be enabled or disabled, and it can be relocated to the top of any 64KB page in memory. Data is passed to and from RAM via the 8-bit data bus. On-chip RAM operates with zero wait states. EMAC RAM is accessed via the bus arbiter and can execute with zero or one wait states.

General-purpose RAM occupies memory addresses in the RAM Address Upper Byte register, in the range $\{RAM_ADDR_U[7:0], E000h\}$ to $\{RAM_ADDR_U[7:0], FFFFh\}$. EMAC RAM occupies memory addresses in the range $\{RAM_ADDR_U[7:0], C000h\}$ to $\{RAM_ADDR_U[7:0], DFFFh\}$. Following a RESET, RAM is enabled when RAM_ADDR_U is set to FFh. Figure 21 illustrates a memory map for on-chip RAM. In this example, RAM_ADDR_U is set to 7Ah. Figure 21 is not drawn to scale, as RAM occupies only a very small fraction of the available 16MB address space.

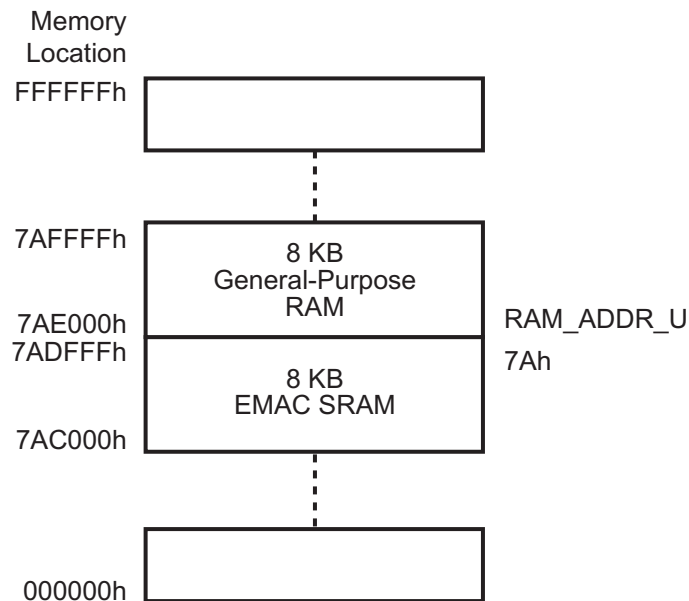

Figure 21. Example: eZ80F91 On-Chip RAM Memory Addressing

When enabled, on-chip RAM assumes priority over on-chip Flash Memory and any Memory Chip Selects that can also be enabled in the same address space. If an address is generated in a range that is covered by both the RAM address



space and a particular Memory Chip Select address space, the Memory Chip Select is not activated. On-chip RAM is not accessible to external devices during bus acknowledge cycles.

RAM Control Registers

RAM Control Register

Internal data RAM can be disabled by clearing the GPRAM_EN bit. The default upon RESET is for RAM to be enabled. See Table 31.

**Table 31. RAM Control Register
(RAM_CTL=00B4h)**

| Bit | 7 | 6 | 5 | 4 | 3 | 2 | 1 | 0 |
|-------------------|-----|-----|---|---|---|---|---|---|
| Reset | 1 | 1 | 0 | 0 | 0 | 0 | 0 | 0 |
| CPU Access | R/W | R/W | R | R | R | R | R | R |

Note: R/W = Read/Write; R = Read Only.

| Bit Position | Value | Description |
|---------------|--------|--|
| 7 GPRAM_EN | 0 | On-chip general-purpose RAM is disabled. |
| | 1 | On-chip general-purpose RAM is enabled. |
| 6 ERAM_EN | 0 | On-chip EMAC RAM is disabled. |
| | 1 | On-chip EMAC RAM is enabled. |
| [5:0] | 000000 | Reserved |



RAM Address Upper Byte Register

The RAM_ADDR_U register defines the upper byte of the address for on-chip RAM. If enabled, RAM addresses assume priority over all Chip Selects. The external Chip Select signals are not asserted if the corresponding RAM address is enabled. See Table 32.

Table 32. RAM Address Upper Byte Register (RAM_ADDR_U=00B5h)

| Bit | 7 | 6 | 5 | 4 | 3 | 2 | 1 | 0 |
|-------------------|-----|-----|-----|-----|-----|-----|-----|-----|
| Reset | 1 | 1 | 1 | 1 | 1 | 1 | 1 | 1 |
| CPU Access | R/W | R/W | R/W | R/W | R/W | R/W | R/W | R/W |

Note: R/W = Read/Write.

| Bit Position | Value | Description |
|---------------------|-------------|---|
| [7:0] RAM_ADDR_U | 00h– FFh | This byte defines the upper byte of the RAM address. When enabled, the general-purpose RAM address space ranges from {RAM_ADDR_U, E000h} to {RAM_ADDR_U, FFFFh}. When enabled, the EMAC RAM address space ranges from {RAM_ADDR_U, C000h} to {RAM_ADDR_U, DFFFh}. |



MBIST Control

There are two Memory Built-In Self-Test (MBIST) controllers for the RAM blocks on the eZ80F91. MBIST_GPR is for General Purpose RAM and MBIST_EMR is for EMAC RAM. Writing a 1 to MBIST_ON starts the MBIST testing. Writing a 0 to MBIST_ON stops the MBIST testing. Upon completion of the MBIST testing, MBIST_ON is automatically reset to 0. If RAM passes MBIST testing, MBIST_PASS is 1. The value in MBIST_PASS is only valid when MBIST_DONE is High. See Table 33.

**Table 33. MBIST Control Register
(MBIST_GPR=00B6h, MBIST_EMR=00B7h)**

| Bit | 7 | 6 | 5 | 4 | 3 | 2 | 1 | 0 |
|-------------------|-----|---|---|---|---|---|---|---|
| Reset | 0 | 0 | 0 | 0 | 0 | 0 | 0 | 0 |
| CPU Access | R/W | R | R | R | R | R | R | R |

Note: R/W = Read/Write; R = Read Only.

| Bit Position | Value | Description |
|-----------------|-------|---------------------------------------|
| 7 MBIST_ON | 0 | MBIST Testing of the RAM is disabled. |
| | 1 | MBIST Testing of the RAM is enabled. |
| 6 MBIST_DONE | 0 | MBIST Testing has not completed. |
| | 1 | MBIST Testing has completed. |
| 5 MBIST_PASS | 0 | MBIST Testing has failed. |
| | 1 | MBIST Testing has passed. |
| [4:0] | 00000 | Reserved |



Flash Memory

Flash Memory Arrangement in the eZ80F91 Device

The eZ80F91 device features 256KB (262,144 bytes) of nonvolatile Flash memory with Read/Write/Erase capability. The main Flash memory array is arranged in 128 pages with 8 rows per page and 256 bytes per row. In addition to main Flash memory, there are two separately-addressable rows which comprise a 512-byte information page.

256KB of main storage can be protected in eight 32KB blocks. Protecting a 32KB block prevents Write or Erase operations. The lower 32KB block (00000h–07FFFh) can be protected using the external WP pin. This portion of memory is called the Boot Block because the CPU always starts executing code from this location at startup. If the application requires external program memory, then the Boot Block must at least contain a jump instruction to move the Program Counter outside of the Flash memory space.

The Flash memory arrangement is illustrated in Figure 22.

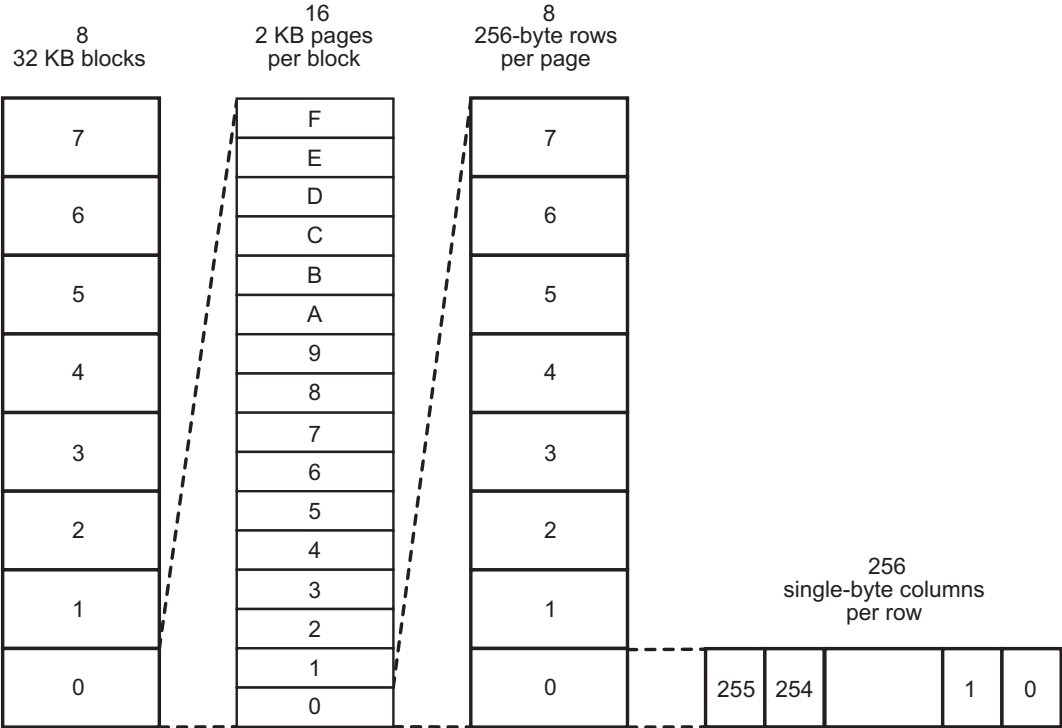

Figure 22. eZ80F91 Flash Memory Arrangement

Flash Memory Overview

The eZ80F91 device includes a Flash memory controller that automatically converts standard CPU Read and Write cycles to the specific protocol required for the Flash memory array. As such, standard memory Read and Write instructions access the Flash memory array as if it is internal RAM. The controller also supports I/O access to the Flash memory array, in effect presenting it as an indirectly-addressable bank of I/O registers. These access methods are also supported via the ZDI and OCI interfaces.

In addition, eZ80Acclaim! Flash Microcontrollers support a Flash Read-While-Write methodology. In essence, the eZ80[®] CPU can continue to read and execute code from an area of Flash memory while a nonconflicting area of Flash memory is being programmed.

The Flash memory controller contains a frequency divider, a Flash register interface, and a Flash control state machine. A simplified block diagram of the Flash controller is illustrated in Figure 23.

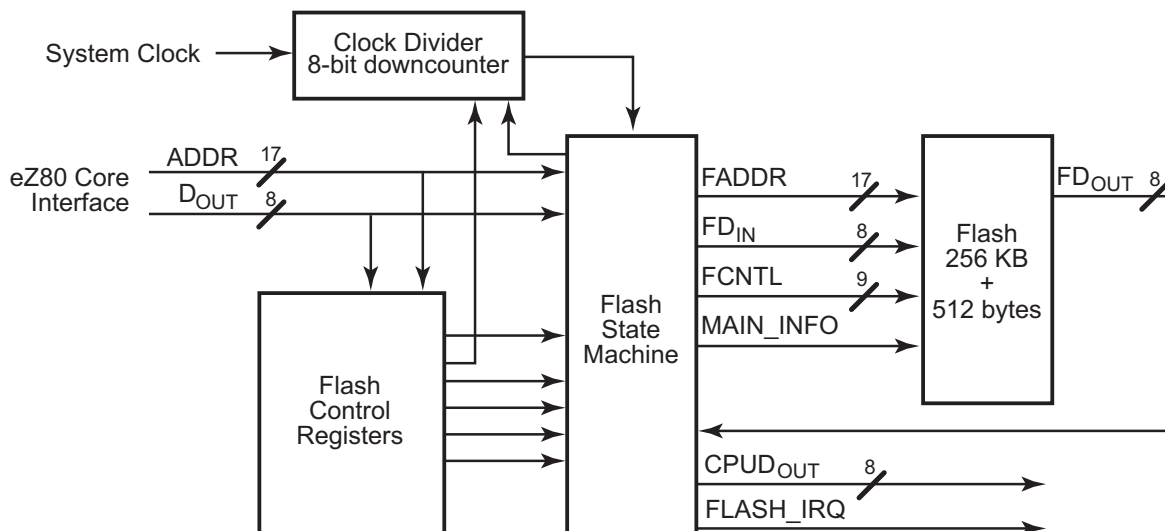

Figure 23. Flash Memory Block Diagram

Reading Flash Memory

The main Flash memory array can be read using both Memory and I/O operations. As an auxiliary storage area, the information page is only accessible via I/O operations. In all cases, wait states are automatically inserted to allow for read access time.

Memory Read

A memory Read operation uses the address bus and data bus of the eZ80F91 device to read a single data byte from Flash memory. This Read operation is similar to reads from RAM. To perform Flash memory reads, the FLASH_CTRL register must be configured to enable memory access to Flash with the appropriate number of wait states. See [Table 37](#) on page 113.

Only the main area of Flash memory is accessible via memory reads. The information page must be read using I/O access.

I/O Read

A single-byte I/O Read operation uses I/O registers for setting the column, page, and row address to be read. A Read of the FLASH_DATA register returns the contents of Flash memory at the designated address. Each access to the FLASH_DATA register causes an autoincrement of the Flash address stored in the Flash address registers (FLASH_PAGE, FLASH_ROW, FLASH_COL). To allow for Flash memory access time, the FLASH_CTRL register must be configured with the appropriate number of wait states. See [Table 37](#) on page 113.

Programming Flash Memory

Flash memory is programmed using standard I/O or memory Write operations that the Flash memory controller automatically translates to the detailed timing and protocol required for Flash memory. The more efficient multibyte (row) programming mode is only available via I/O Writes.

- **Note:** To ensure data integrity and device reliability, two main restrictions exist on programming of Flash memory:
1. The cumulative programming time since the last erase cannot exceed 31 ms for any given row.
 2. The same byte cannot be programmed more than twice since the last erase.

Single-Byte I/O Write

A single-byte I/O Write operation uses I/O registers for setting the column, page, and row address to be written. The FLASH_DATA register stores the data to be written. While the CPU executes an I/O instruction to load the data into the FLASH_DATA register, the Flash controller asserts the internal WAIT signal to stall the CPU until the Flash Write operation is complete. A single-byte Write takes between 66 μ s and 85 μ s to complete. Programming an entire row (256 bytes) using single-byte Writes therefore takes no more than 21.8ms. This duration of time does not include the time required by the CPU to transfer data to the registers, which is a function of the instructions employed and the system clock frequency. Each access to the FLASH_DATA register causes an autoincrement of

the Flash address stored in the Flash Address registers (FLASH_PAGE, FLASH_ROW, FLASH_COL).

A typical sequence that performs a single-byte I/O Write is shown below. Because the Write is self-timed, Step 2 of the sequence can be repeated back-to-back without requiring polling or interrupts.

1. Write the FLASH_PAGE, FLASH_ROW, and FLASH_COL registers with the address of the byte to be written.
2. Write the data value to the FLASH_DATA register.

Multibyte I/O Write (Row Programming)

Multibyte I/O Write operations use the same I/O registers as single-byte Writes. Multibyte I/O Writes allow the programming of a full row and are enabled by setting the ROW_PGM bit of the Flash Program Control Register. For multibyte I/O Writes, the CPU sets the address registers, enables row programming, and then executes an I/O instruction (with repeat) to load the block of data into the FLASH_DATA register. For each individual byte written to the FLASH_DATA register during the block move, the Flash controller asserts the internal WAIT signal to stall the CPU until the current byte is programmed. Each access to the FLASH_DATA register causes an autoincrement of the Flash address stored in the Flash Address registers (FLASH_PAGE, FLASH_ROW, FLASH_COL).

During row programming, the Flash controller continuously asserts the Flash memory's high voltage signal until all bytes are programmed (column address < 255). As a result, the row programs more quickly than if the high-voltage signal is toggled for each byte. The per-byte programming time during row programming is between 41 μ s and 52 μ s. As such, programming 256 bytes of a row in this mode takes no more than 13.4ms, leaving 17.6ms for CPU instruction overhead to fetch the 256 bytes.

A typical sequence that performs a multibyte I/O Write is shown below.

1. Check the FLASH_IRQ register to ensure that any previous row program is completed.
2. Write the FLASH_PAGE, FLASH_ROW, and FLASH_COL registers with the address of the first byte to be written.
3. Set the ROW_PGM bit in the FLASH_PGCTL register to enable row programming mode.
4. Write the next data value to the FLASH_DATA register.
5. If the end of the row has not been reached, return to Step 4.

During row programming, software must monitor the row time-out error bit either by enabling this interrupt or via polling. If a row time-out occurs, the Flash control-

ler aborts the row programming operation, and software must assure that no further Writes are performed to the row without it first being erased. It is suggested that row programming only be used one time per row and not in combination with single-byte Writes to the same row without first erasing it. Otherwise, the burden is on software to ensure that the 31 ms maximum cumulative programming time between erases is not exceeded for a row.

Memory Write

A single-byte memory Write operation uses the address bus and data bus of the eZ80F91 device for programming a single data byte to Flash memory. While the CPU executes a Load instruction, the Flash controller asserts the internal WAIT signal to stall the CPU until the Write is complete. A single-byte Write takes between 66 μ s and 85 μ s to complete. Programming an entire row using memory Writes therefore takes no more than 21.8ms. This duration of time does not include time required by the CPU to transfer data to the registers, which is a function of the instructions employed and the system clock frequency.

The memory Write function does not support multibyte row programming. Because memory Writes are self-timed, they can be performed back-to-back without requiring polling or interrupts.

Erasing Flash Memory

Erasing bytes in Flash memory returns them to a value of FFh. Both the MASS and PAGE ERASE operations are self-timed by the Flash controller, leaving the CPU free to execute other operations in parallel. The DONE status bit in the Flash Interrupt Control Register can be polled by software or used as an interrupt source to signal completion of an Erase operation. If the CPU attempts to access Flash memory while an erase is in progress, the Flash controller forces a wait state until the Erase operation is completed.

Mass Erase

Performing a MASS ERASE operation on Flash memory erases all bits contained in Flash, including the information page. This self-timed operation takes approximately 200ms to complete.

Page Erase

The smallest erasable unit in Flash memory is a page. The pages to be erased, whether they are the 128 main Flash memory pages or the information page, is determined by the setting of the FLASH_PAGE register. This self-timed operation takes approximately 10ms to complete.



Information Page Characteristics

As noted earlier, the information page is not accessible using memory access instructions and must be accessed via the I/O register. The Flash Page Select Register contains a bit which selects the information page for I/O access.

There are two ways to erase the information page. The user can execute a MASS ERASE operation, or the user can configure the Flash Page Select Register to select the information page, and then execute a PAGE ERASE.

www.DataSheet4U.com

Flash Control Registers

The Flash Control Register interface contains all of the registers used in Flash memory. The definitions in this section describe each register.

Flash Key Register

Writing the two-byte sequence B6h, 49h in immediate succession to this register unlocks the Flash Divider and Flash Write/Erase Protection registers. If these values are not written by consecutive CPU I/O Writes (I/O reads and memory Read/Writes have no effect), the Flash Divider and Flash Write/Erase Protection registers remain locked. This prevents accidental overwrites of these critical Flash control register settings. Writing a value to either the Flash Frequency Divider register or the Flash Write/Erase Protection register automatically relocks both of the registers. See Table 34.

**Table 34. Flash Key Register
(FLASH_KEY = 00F5h)**

| Bit | 7 | 6 | 5 | 4 | 3 | 2 | 1 | 0 |
|------------|---|---|---|---|---|---|---|---|
| Reset | 0 | 0 | 0 | 0 | 0 | 0 | 0 | 0 |
| CPU Access | W | W | W | W | W | W | W | W |

Note: W = Write Only.

| Bit Position | Value | Description |
|--------------------|-------------|---|
| [7:0] FLASH_KEY | B6h, 49h | Sequential Write operations of the values B6h, 49h to this register will unlock the Flash Frequency Divider and Flash Write/Erase Protection registers. |



Flash Data Register

The Flash Data register stores the data values to be programmed into Flash memory via I/O Write operations. An I/O Read of the Flash Data register returns data from Flash memory. The Flash memory address used for I/O access is determined by the contents of the page, row, and column registers. Each access to the FLASH_DATA register causes an autoincrement of the Flash address stored in the Flash Address registers (FLASH_PAGE, FLASH_ROW, FLASH_COL). See Table 35.

**Table 35. Flash Data Register
(FLASH_DATA = 00F6h)**

| Bit | 7 | 6 | 5 | 4 | 3 | 2 | 1 | 0 |
|-------------------|-----|-----|-----|-----|-----|-----|-----|-----|
| Reset | X | X | X | X | X | X | X | X |
| CPU Access | R/W | R/W | R/W | R/W | R/W | R/W | R/W | R/W |

Note: R/W = Read/Write.

| Bit Position | Value | Description |
|---------------------|-------------|--|
| [7:0] FLASH_DATA | 00h- FFh | Data value to be written to Flash memory during an I/O Write operation, or the data value that is read in Flash memory, indicated by the Flash Address registers (FLASH_PAGE, FLASH_ROW, FLASH_COL). |



Flash Address Upper Byte Register

The FLASH_ADDR_U register defines the upper 6 bits of the Flash memory address space. Changing the value of FLASH_ADDR_U allows on-chip 256KB Flash memory to be mapped to any location within the 16MB linear address space of the eZ80F91 device. If on-chip Flash memory is enabled, the Flash address assumes priority over any external Chip Selects. The external Chip Select signals are not asserted if the corresponding Flash address is enabled. Internal Flash memory does not hold priority over internal SRAM. See Table 36.

**Table 36. Flash Address Upper Byte Register
(FLASH_ADDR_U = 00F7h)**

| Bit | 7 | 6 | 5 | 4 | 3 | 2 | 1 | 0 |
|-------------------|-----|-----|-----|-----|-----|-----|---|---|
| Reset | 0 | 0 | 0 | 0 | 0 | 0 | 0 | 0 |
| CPU Access | R/W | R/W | R/W | R/W | R/W | R/W | R | R |

Note: R/W = Read/Write; R = Read Only.

| Bit Position | Value | Description |
|-----------------------|-------------|--|
| [7:2] FLASH_ADDR_U | 00h– FCh | These bits define the upper byte of the Flash address. When on-chip Flash is enabled, the Flash address space begins at address {FLASH_ADDR_U, 00b, 0000h}. On-chip Flash has priority over all external Chip Selects. |
| [1:0] | 00 | Reserved (enforces alignment on a 256KB boundary). |



Flash Control Register

The Flash Control register enables or disables memory access to Flash memory. I/O access to the Flash control registers and to Flash memory is still possible while Flash memory space access is disabled.

The minimum access time of internal Flash memory is 60ns. The Flash Control Register must be configured to provide the appropriate number of wait states based on the system clock frequency of the eZ80F91 device. Because the maximum SCLK frequency is 50MHZ (20ns), the default upon RESET is for four wait states to be inserted for Flash memory access (Flash memory access + one eZ80 Bus Cycle = 60ns + 20ns = 80ns; 80ns ÷ 20ns = 4 wait states). See Table 37.

**Table 37. Flash Control Register
(FLASH_CTRL = 00F8h)**

| Bit | 7 | 6 | 5 | 4 | 3 | 2 | 1 | 0 |
|-------------------|-----|-----|-----|---|-----|---|---|---|
| Reset | 1 | 0 | 0 | 0 | 1 | 0 | 0 | 0 |
| CPU Access | R/W | R/W | R/W | R | R/W | R | R | R |

Note: R/W = Read/Write, R = Read Only.

| Bit Position | Value | Description |
|---------------------|-------|--|
| [7:5] FLASH_WAIT | 000 | 0 wait states are inserted when the Flash is active. |
| | 001 | 1 wait state is inserted when the Flash is active. |
| | 010 | 2 wait states are inserted when the Flash is active. |
| | 011 | 3 wait states are inserted when the Flash is active. |
| | 100 | 4 wait states are inserted when the Flash is active. |
| | 101 | 5 wait states are inserted when the Flash is active. |
| | 110 | 6 wait states are inserted when the Flash is active. |
| | 111 | 7 wait states are inserted when the Flash is active. |
| [4] | 0 | Reserved |
| [3] FLASH_EN | 0 | Flash memory access is disabled. |
| | 1 | Flash memory access is enabled. |
| [2:0] | 000 | Reserved |



Flash Frequency Divider Register

The 8-bit frequency divider allows the programming of Flash memory over a range of system clock frequencies. Flash can be programmed with system clock frequencies ranging from 154 kHz to 50 MHz. The Flash controller requires an input clock with a period that falls within the range of 5.1–6.5 μs. The period of the Flash controller clock is set in the Flash Frequency Divider Register. Writes to this register are allowed only after it is unlocked via the FLASH_KEY register. The Flash Frequency Divider Register value required vs. the system clock frequency is shown in Table 38. System clock frequencies outside of the ranges shown are not supported. Register values for the Flash Frequency Divider are shown in Table 39.

Table 38. Flash Frequency Divider Values

| System Clock Frequency | Flash Frequency Divider Value |
|------------------------|--|
| 154–196 kHz | 1 |
| 308–392 kHz | 2 |
| 462–588 kHz | 3 |
| 616 kHz–50 MHz | CEILING [System Clock Frequency (MHz) x 5.1 (μs)]* |

Note: *The CEILING function rounds fractional values up to the next whole number. For example, CEILING(3.01) is 4.

Table 39. Flash Frequency Divider Register (FLASH_FDIV = 00F9h)

| Bit | 7 | 6 | 5 | 4 | 3 | 2 | 1 | 0 |
|-------------------|------|------|------|------|------|------|------|-----|
| Reset | 0 | 0 | 0 | 0 | 0 | 0 | 0 | 1 |
| CPU Access | R/W* | R/W* | R/W* | R/W* | R/W* | R/W* | R/W* | R/W |

Note: R/W = Read/Write, R = Read Only. *Key sequence required to enable Writes

| Bit Position | Value | Description |
|---------------------|-------------|---|
| [7:0] FLASH_FDIV | 01h– FFh | Divider value for generating the required 5.1-6.5 μs Flash controller clock period. |



Flash Write/Erase Protection Register

The Flash Write/Erase Protection register prevents accidental Write or Erase operations. The protection is limited to a resolution of eight 32KB blocks. Setting a bit to 1 protects that 32KB block of Flash memory from accidental Writes or erases. The default upon RESET is for all Flash memory blocks to be protected.

The \overline{WP} pin works in conjunction with FLASH_PROT[0] to protect the lowest block (also called the Boot Block) of Flash memory. If either the WP is held asserted or FLASH_PROT[0] is set, the Boot Block is protected from Write and Erase operations.

- **Note:** A protect bit is not available for the information page. The information page is, however, protected from a MASS ERASE if any pages are protected in FLASH_PROT or WP is asserted.

Writes to this register are allowed only after it is unlocked via the FLASH_KEY register. Any attempted Writes to this register while locked will set it to FFh, thereby protecting all blocks. See Table 40.

Table 40. Flash Write/Erase Protection Register (FLASH_PROT = 00FAh)

| Bit | 7 | 6 | 5 | 4 | 3 | 2 | 1 | 0 |
|------------|------|------|------|------|------|------|------|------|
| Reset | 1 | 1 | 1 | 1 | 1 | 1 | 1 | 1 |
| CPU Access | R/W* | R/W* | R/W* | R/W* | R/W* | R/W* | R/W* | R/W* |

Note: R/W = Read/Write if unlocked, R = Read Only if locked. *Key sequence required to unlock.

| Bit Position | Value | Description |
|------------------|-------|--|
| [7] BLK7_PROT | 0 | Disable Write/Erase Protect on block 38000h to 3FFFFh. |
| | 1 | Enable Write/Erase Protect on block 38000h to 3FFFFh. |
| [6] BLK6_PROT | 0 | Disable Write/Erase Protect on block 30000h to 37FFFh. |
| | 1 | Enable Write/Erase Protect on block 30000h to 37FFFh. |
| [5] BLK5_PROT | 0 | Disable Write/Erase Protect on block 28000h to 2FFFFh. |
| | 1 | Enable Write/Erase Protect on block 28000h to 2FFFFh. |
| [4] BLK4_PROT | 0 | Disable Write/Erase Protect on block 20000h to 27FFFh. |
| | 1 | Enable Write/Erase Protect on block 20000h to 27FFFh. |

Note: The lower 32KB block (00000h to 07FFFh—BLK0) is called the Boot Block and can be protected using the external WP pin.



| Bit Position | Value | Description |
|------------------|-------|--|
| [3] BLK3_PROT | 0 | Disable Write/Erase Protect on block 18000h to 1FFFFh. |
| | 1 | Enable Write/Erase Protect on block 18000h to 1FFFFh. |
| [2] BLK2_PROT | 0 | Disable Write/Erase Protect on block 10000h to 17FFFh. |
| | 1 | Enable Write/Erase Protect on block 10000h to 17FFFh. |
| [1] BLK1_PROT | 0 | Disable Write/Erase Protect on block 08000h to 0FFFFh. |
| | 1 | Enable Write/Erase Protect on block 08000h to 0FFFFh. |
| [0] BLK0_PROT | 0 | Disable Write/Erase Protect on block 00000h to 07FFFh. |
| | 1 | Enable Write/Erase Protect on block 00000h to 07FFFh. |

Note: The lower 32KB block (00000h to 07FFFh—BLK0) is called the Boot Block and can be protected using the external WP pin.

Flash Interrupt Control Register

There are two sources of interrupts from the Flash controller. These two sources are:

- Page Erase, Mass Erase, or Row Program completed successfully.
- An error condition occurred

Either or both of these two interrupt sources can be enabled by setting the appropriate bits in the Flash Interrupt Control register.

The Flash Interrupt Control register contains four status bits to indicate the following error conditions:

Row Program Time-Out. This bit signals a time-out during Row Programming. If the current row program operation does not complete within 4864 Flash controller clocks, the Flash controller terminates the row program operation by clearing bit 2 of the Flash Program Control Register and setting the RP_TM0 error bit to 1.

Write Violation. This bit indicates an attempt to write to a protected block of Flash memory (the Write was not performed).

Page Erase Violation. This bit indicates an attempt to erase a protected block of Flash memory (the requested page was not erased).

Mass Erase Violation. This bit indicates an attempt to MASS ERASE when there are one or more protected blocks in Flash memory (the MASS ERASE was not performed).



If the error condition interrupt is enabled, any of these four error conditions result in an interrupt request being sent to the eZ80F91 device's interrupt controller. Reading the Flash Interrupt Control register clears all error condition flags and the DONE flag. See Table 41.

Table 41. Flash Interrupt Control Register (FLASH_IRQ = 00FBh)

| Bit | 7 | 6 | 5 | 4 | 3 | 2 | 1 | 0 |
|-------------------|-----|-----|---|---|---|---|---|---|
| Reset | 0 | 0 | 0 | 0 | 0 | 0 | 0 | 0 |
| CPU Access | R/W | R/W | R | R | R | R | R | R |

Note: R/W = Read/Write, R = Read Only. Read resets bits [5] and [3:0].

| Bit Position | Value | Description |
|-----------------|-------|---|
| [7] DONE_IEN | 0 | Flash Erase/Row Program Done Interrupt is disabled. |
| | 1 | Flash Erase/Row Program Done Interrupt is enabled. |
| [6] ERR_IEN | 0 | Error Condition Interrupt is disabled. |
| | 1 | Error Condition Interrupt is enabled. |
| [5] DONE | 0 | Erase/Row Program Done Flag is not set. |
| | 1 | Erase/Row Program Done Flag is set. |
| [4] | 0 | Reserved. |
| [3] WR_VIO | 0 | The Write Violation Error Flag is not set. |
| | 1 | The Write Violation Error Flag is set. |
| [2] RP_TMO | 0 | The Row Program Time-Out Error Flag is not set. |
| | 1 | The Row Program Time-Out Error Flag is set. |
| [1] PG_VIO | 0 | The Page Erase Violation Error Flag is not set. |
| | 1 | The Page Erase Violation Error Flag is set. |
| [0] MASS_VIO | 0 | The Mass Erase Violation Error Flag is not set. |
| | 1 | The Mass Erase Violation Error Flag is set. |

Note: The lower 32KB block (00000h to 07FFFh) is called the Boot Block and can be protected using the external WP pin. Attempts to page erase BLK0 or mass erase Flash when WP is asserted result in failure and signal an erase violation.



Flash Page Select Register

The msb of this register is used to select whether I/O Flash access and PAGE ERASE operations are directed to the 512-byte information page or to the main Flash memory array. The lower 7 bits are used to select one of the main 128 pages for PAGE ERASE or I/O operations.

To perform a PAGE ERASE, the software must set the proper page value prior to setting the page erase bit in the Flash Control Register. In addition, each access to the FLASH_DATA register causes an autoincrement of the Flash address stored in the Flash Address registers (FLASH_PAGE, FLASH_ROW, FLASH_COL). See Table 42.

**Table 42. Flash Page Select Register
(FLASH_PAGE = 00FCh)**

| Bit | 7 | 6 | 5 | 4 | 3 | 2 | 1 | 0 |
|-------------------|-----|-----|-----|-----|-----|-----|-----|-----|
| Reset | 0 | 0 | 0 | 0 | 0 | 0 | 0 | 0 |
| CPU Access | R/W | R/W | R/W | R/W | R/W | R/W | R/W | R/W |

Note: R/W = Read/Write, R = Read Only.

| Bit Position | Value | Description |
|---------------------|-------------|--|
| [7] INFO_EN | 0 1 | Flash I/O access to main Flash memory. Flash I/O access to the information page. PAGE ERASE and MASS ERASE operations only affect the information page. |
| [6:0] FLASH_PAGE | 00h– FFh | Page address of Flash memory to be used during the PAGE ERASE or I/O access of main Flash memory. When INFO_EN is set to 1, this field is ignored. |



Flash Row Select Register

The Flash Row Select Register is a 3-bit value used to define one of the 8 rows of Flash on a single page. This register is used for all I/O access to Flash memory. In addition, each access to the FLASH_DATA register causes an autoincrement of the Flash address stored in the Flash Address registers (FLASH_PAGE, FLASH_ROW, FLASH_COL). See Table 43.

**Table 43. Flash Row Select Register
(FLASH_ROW = 00FDh)**

| Bit | 7 | 6 | 5 | 4 | 3 | 2 | 1 | 0 |
|-------------------|---|---|---|---|---|-----|-----|-----|
| Reset | X | X | X | X | X | 0 | 0 | 0 |
| CPU Access | R | R | R | R | R | R/W | R/W | R/W |

Note: R/W = Read/Write, R = Read Only.

| Bit Position | Value | Description |
|--------------------|-------|--|
| [7:3] | 00h | Reserved. |
| [2:0] FLASH_ROW | 0h–7h | Row address of Flash memory to be used during an I/O access of Flash memory. When INFO_EN is 1 in the Flash Page Select Register, values for this field are restricted to 0h–1h, which selects between the two rows in the information page. |



Flash Column Select Register

The Flash Column Select Register is an 8-bit value used to define one of the 256 bytes of Flash memory contained in a single row. This register is used for all I/O access to Flash memory. In addition, each access to the FLASH_DATA register causes an autoincrement of the Flash address stored in the Flash Address registers (FLASH_PAGE, FLASH_ROW, FLASH_COL). See Table 44.

Table 44. Flash Column Select Register (FLASH_COL = 00FEh)

| Bit | 7 | 6 | 5 | 4 | 3 | 2 | 1 | 0 |
|-------------------|-----|-----|-----|-----|-----|-----|-----|-----|
| Reset | 0 | 0 | 0 | 0 | 0 | 0 | 0 | 0 |
| CPU Access | R/W | R/W | R/W | R/W | R/W | R/W | R/W | R/W |

Note: R/W = Read/Write, R = Read Only.

| Bit Position | Value | Description |
|--------------------|-------------|---|
| [7:0] FLASH_COL | 00h– FFh | Column address of Flash memory to be used during an I/O access of Flash memory. |

Flash Program Control Register

The Flash Program Control Register is used to perform the functions of MASS ERASE, PAGE ERASE, and ROW PROGRAM.

MASS ERASE and PAGE ERASE are self-clearing functions. MASS ERASE requires approximately 200ms to erase the full 256KB of main Flash and the 512-byte information page. PAGE ERASE requires approximately 10ms to erase a 2KB page. Upon completion of either a MASS ERASE or PAGE ERASE, the value of each corresponding bit is reset to 0.

While Flash is being erased, any Read or Write access to Flash forces the CPU into a wait state until the Erase operation is complete and the Flash can be accessed. Reads and Writes to areas other than Flash memory can proceed as usual while an Erase operation is underway.

During row programming, any reads of Flash memory force a WAIT condition until the row programming operation completes or times out. See Table 45.



**Table 45. Flash Program Control Register
(FLASH_PGCTL = 00FFh)**

| Bit | 7 | 6 | 5 | 4 | 3 | 2 | 1 | 0 |
|-------------------|---|---|---|---|---|-----|-----|-----|
| Reset | 0 | 0 | 0 | 0 | 0 | 0 | 0 | 0 |
| CPU Access | R | R | R | R | R | R/W | R/W | R/W |

Note: R/W = Read/Write, R = Read Only.

| Bit Position | Value | Description |
|-------------------|-------|--|
| [7:3] | 00h | Reserved. |
| [2] ROW_PGM | 0 | Row Program Disable or Row Program completed. |
| | 1 | Row Program Enable. This bit automatically resets to 0 when the row address reaches 256 or when the Row Program operation times out. |
| [1] PG_ERASE | 0 | Page Erase Disable (Page Erase completed). |
| | 1 | Page Erase Enable. This bit automatically resets to 0 when the PAGE ERASE operation is complete. |
| [0] MASS_ERASE | 0 | Mass Erase Disable (Mass Erase completed). |
| | 1 | Mass Erase Enable. This bit automatically resets to 0 when the MASS ERASE operation is complete. |

Watch-Dog Timer

Watch-Dog Timer Overview

The Watch-Dog Timer (WDT) helps protect against corrupt or unreliable software, power faults, and other system-level problems which can place the CPU into unsuitable operating states. The eZ80F91 WDT features:

- Four programmable time-out periods: 2^{18} , 2^{22} , 2^{25} , and 2^{27} clock cycles
- Three selectable WDT clock sources:
 - Internal RC oscillator
 - System clock
 - Real-Time Clock source (on-chip 32Khz crystal oscillator or 50/60Hz signal)
- A selectable time-out response: a time-out can be configured to generate either a RESET or a nonmaskable interrupt (NMI)
- A WDT time-out RESET indicator flag

Figure 24 illustrates a block diagram of the Watch-Dog Timer.

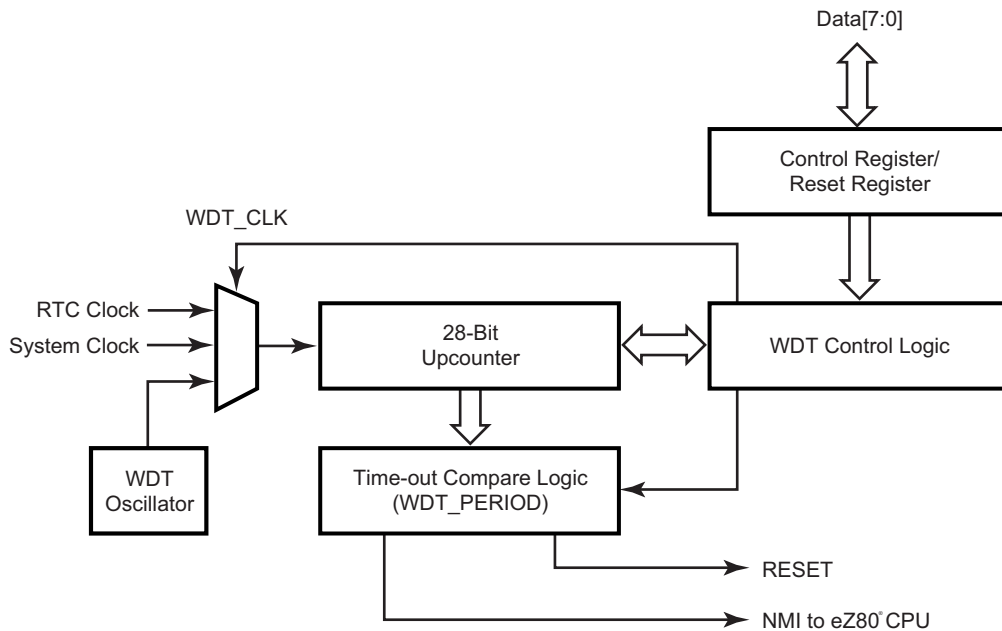

Figure 24. Watch-Dog Timer Block Diagram



Watch-Dog Timer Operation

Enabling and Disabling the WDT

The Watch-Dog Timer is disabled upon a RESET. To enable the WDT, the application program must set WDT_EN, which corresponds to bit 7 of the WDT_CTL register. After WDT_EN is set, no Writes are allowed to the WDT_CTL register. When enabled, the WDT cannot be disabled, except by a RESET.

Time-Out Period Selection

There are four choices of time-out periods for the WDT— 2^{18} , 2^{22} , 2^{25} , and 2^{27} timer clock cycles. The WDT time-out period is defined by the WDT_PERIOD field of the WDT_CTL register (WDT_CTL[1:0]). The approximate time-out periods for two different WDT clock sources are listed in Table 46. The approximate time-out period for the third WDT clock source is listed in Table 47.

Table 46. Watch-Dog Timer Approximate Time-Out Delays

| Clock Source | Divider Value | Time Out Delay |
|------------------------------|---------------|----------------|
| 32.768KHz Crystal Oscillator | 2^{18} | 8.00s |
| 32.768KHz Crystal Oscillator | 2^{22} | 128s |
| 32.768KHz Crystal Oscillator | 2^{25} | 1024s |
| 32.768KHz Crystal Oscillator | 2^{27} | 4096s |
| 50MHz System Clock | 2^{18} | 5.2ms |
| 50MHz System Clock | 2^{22} | 83.9ms |
| 50MHz System Clock | 2^{25} | 0.67s |
| 50MHz System Clock | 2^{27} | 2.68s |

Table 47. Watch-Dog Timer Approximate Time-Out Delays w/ Internal RC Oscillator

| Clock Source | Divider Value | Minimum Time-Out Delay | Typical Time-Out Delay |
|------------------------|---------------|------------------------|------------------------|
| Internal RC Oscillator | 2^{18} | 16s | 26s |
| Internal RC Oscillator | 2^{22} | 262s | 419s |
| Internal RC Oscillator | 2^{25} | 2100s | 3360s |
| Internal RC Oscillator | 2^{27} | 8390s | 13400s |



RESET Or NMI Generation

A WDT time-out causes a RESET or sends a nonmaskable interrupt (NMI) signal to the CPU. The default operation is for the WDT to cause a RESET.

If the NMI_OUT bit in the WDT_CTL register is set to 0, then upon a WDT time-out, the RST_FLAG bit in the WDT_CTL register is set to 1. The RST_FLAG bit can be polled by the CPU to determine the source of the RESET event.

If the NMI_OUT bit in the WDT_CTL register is set to 1, then upon time-out, the WDT asserts an NMI for CPU processing. The NMI_FLAG bit can be polled by the CPU to determine the source of the NMI event.

Watch-Dog Timer Registers

Watch-Dog Timer Control Register

The Watch-Dog Timer Control register, detailed in Table 48, is an 8-bit Read/Write register used to enable the Watch-Dog Timer, set the time-out period, indicate the source of the most recent RESET or NMI, and select the required operation upon WDT time-out.

The default clock source for the Watch-Dog Timer is the WDT oscillator (WDT_CLK = 10b). To power-down the WDT oscillator, another clock source must be selected. The power-up sequence of the WDT oscillator takes approximately 20ms.

Table 48. Watch-Dog Timer Control Register
(WDT_CTL = 0093h)

| Bit | 7 | 6 | 5 | 4 | 3 | 2 | 1 | 0 |
|-------------------|-----|-----|-----|---|-----|-----|-----|-----|
| Reset | 0 | 0 | 0/1 | 0 | 1 | 0 | 0 | 0 |
| CPU Access | R/W | R/W | R | R | R/W | R/W | R/W | R/W |

Note: R = Read only; R/W = Read/Write.

| Bit Position | Value | Description |
|--------------|-------|---|
| 7 WDT_EN | 0 | WDT is disabled. |
| | 1 | WDT is enabled. When enabled, the WDT cannot be disabled without a RESET. |
| 6 NMI_OUT | 0 | WDT time-out resets the CPU. |
| | 1 | WDT time-out generates a nonmaskable interrupt (NMI) to the CPU. |



| Bit Position | Value | Description |
|---------------------|-------|--|
| 5 RST_FLAG | 0 | RESET caused by external full-chip reset or ZDI reset. |
| | 1 | RESET caused by WDT time-out. This flag is set by the WDT time-out, only if the NMI_OUT flag is set to 0. The CPU can poll this bit to determine the source of the RESET. This flag is cleared by a non-WDT generated reset. |
| 4 NMI_FLAG | 0 | NMI caused by external source. |
| | 1 | NMI caused by WDT time-out. This flag is set by the WDT time-out, only if the NMI_OUT flag is set to 1. The CPU can poll this bit to determine the source of the NMI. This flag is cleared by a non-WDT NMI. |
| [3:2] WDT_CLK | 00 | WDT clock source is system clock. |
| | 01 | WDT clock source is Real-Time Clock source (32KHz on-chip oscillator or 50/60Hz input as set by RTC_CTRL[4]). |
| | 10 | WDT clock source is internal RC oscillator (10KHz typical). |
| | 11 | Reserved |
| [1:0] WDT_PERIOD | 00 | WDT time-out period is 2^{27} clock cycles. |
| | 01 | WDT time-out period is 2^{25} clock cycles. |
| | 10 | WDT time-out period is 2^{22} clock cycles. |
| | 11 | WDT time-out period is 2^{18} clock cycles. |

Note: When the WDT is enabled, no Writes are allowed to the WDT_CTL register.



Watch-Dog Timer Reset Register

The Watch-Dog Timer Reset register, detailed in Table 49, is an 8-bit Write Only register. The Watch-Dog Timer is reset when an A5h value followed by a 5Ah value is written to this register. Any amount of time can occur between the writing of the A5h value and the 5Ah value, so long as the WDT time-out does not occur prior to completion. Any value other than 5Ah written to the Watch-Dog Timer Reset register after the A5h value requires that the sequence of Writes (A5h,5Ah) be restarted for the timer to be reset.

Table 49. Watch-Dog Timer Reset Register (WDT_RR = 0094h)

| Bit | 7 | 6 | 5 | 4 | 3 | 2 | 1 | 0 |
|------------|---|---|---|---|---|---|---|---|
| Reset | X | X | X | X | X | X | X | X |
| CPU Access | W | W | W | W | W | W | W | W |

Note: X = Undefined; W = Write Only.

| Bit Position | Value | Description |
|-----------------|-------|---|
| [7:0] WDT_RR | A5h | The first Write value required to reset the WDT prior to a time-out. |
| | 5Ah | The second Write value required to reset the WDT prior to a time-out. If an A5h,5Ah sequence is written to WDT_RR, the WDT timer is reset to its initial count value, and counting resumes. |

Programmable Reload Timers

Programmable Reload Timers Overview

The eZ80F91 device features four programmable reload timers. The core of each timer is a 16-bit downcounter. In addition, each timer features a selectable clock source, adjustable prescaling and can operate in either SINGLE PASS or CONTINUOUS mode.

In addition to the basic timer functionality, some of the timers support specialty modes that perform event counting, input capture, output compare, and PWM generation functions. PWM mode supports four individually-configurable outputs and a power trip function.

Each of the 4 timers available on the eZ80F91 device can be controlled individually. They do not share the same counters, reload registers, control registers, or interrupt signals. A simplified block diagram of a programmable reload timer is illustrated in Figure 25.

Each timer features its own interrupt, which is triggered either by the timer reaching zero or after a successful comparison occurs. As with the other eZ80F91 interrupts, the priority is fully programmable.

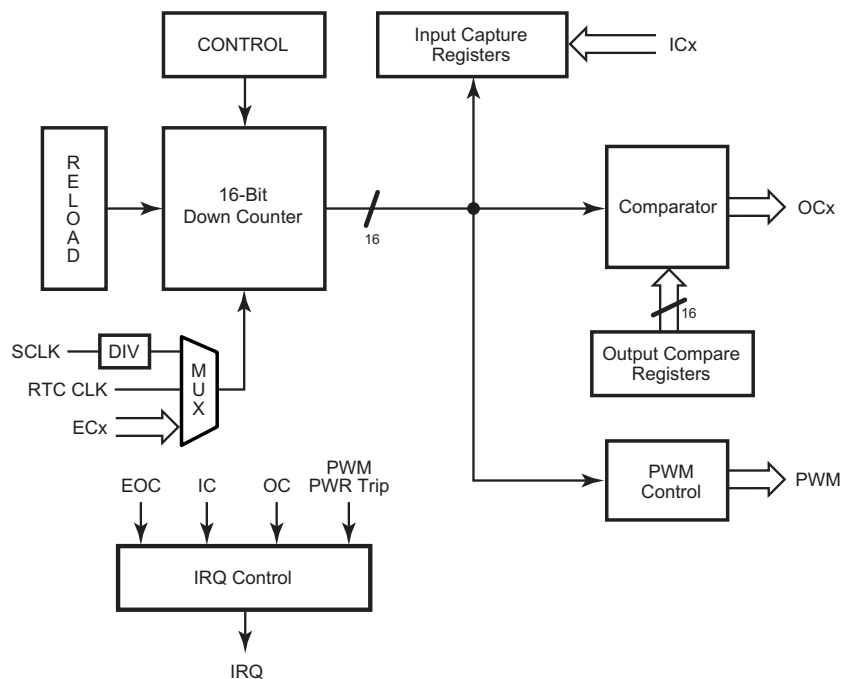

Figure 25. Programmable Reload Timer Block Diagram

Basic Timer Operation

Basic timer operation is controlled by a timer control register and a programmable reload value. The CPU uses the control register to set up the prescaling, the input clock source, the end-of-count behavior, and to start the timer. The 16-bit reload value is used to determine the duration of the timer's count before either halting or reloading.

After choosing a timer period and writing the appropriate values to the reload registers, the CPU must set the timer enable bit (TMRx_CTL[TIM_EN]), allowing the count to begin. The reload bit (TMRx_CTL[RLD]) should also be asserted so that the timer counts down from the reload value, rather than from 0000h. On the system clock cycle, after the assertion of the reload bit, the timer loads with the 16-bit reload value and begins counting down. The reload bit is automatically cleared after the loading operation. The timer can be enabled and reloaded on the same cycle; however, the timer does not require disabling to reload; reloading can be performed at any time. It is also possible to halt the timer by deasserting the timer enable bit and resuming the count at a later time from the same point by reasserting the bit.

Reading the Current Count Value

The CPU can read the current count value while the timer is running. Because the count is a 16-bit value, the hardware latches the value of the upper byte into temporary storage when the lower byte is read. This value in temporary storage is the value returned when the upper byte is read. Therefore, the firmware should read the lower byte first. If it attempts to read the upper byte first, it does not obtain the current upper byte of the count. Instead, it obtains the last latched value. This Read operation does not affect timer operation.

Setting Timer Duration

There are three factors to consider when determining Programmable Reload Timer duration: clock frequency, clock divider ratio, and initial count value. Minimum duration of the timer is achieved by loading 0001h. Maximum duration is achieved by loading 0000h, because the timer first rolls over to FFFFh, then continues counting down to 0000h before the end-of-count is signaled. Depending upon the TMRx_CTL[CLK_SEL] bits of the control register, the clock is either the system clock, the on-chip RC oscillator output or an input from a pin.

The time-out period of the timer is returned by the following equation:

$$\text{Time-Out Period} = \frac{\text{Clock Divider Ratio} \times \text{Reload Value}}{\text{System Clock Frequency}}$$

To calculate the time-out period with the above equation when using an initial value of 0000h, enter a reload value of 65536 (FFFFh + 1).

Minimum time-out duration is 4 times longer than the input clock period and is generated by setting the clock divider ratio to 1:4 and the reload value to 0001h. Maximum time-out duration is 2^{24} (16,777,216) times longer than the input clock period, and is generated by setting the clock divider ratio to 1:256 and the reload value to 0000h.

Single Pass Mode

In SINGLE PASS mode, when the end-of-count value (0000h), is reached, counting halts, the timer is disabled, and the TMRx_CTL[TIM_EN] bit resets to 0. To reenble the timer, the CPU must set the TIM_EN bit to 1. An example of a PRT operating in SINGLE PASS mode is illustrated in Figure 26. Timer register information is indicated in Table 50.

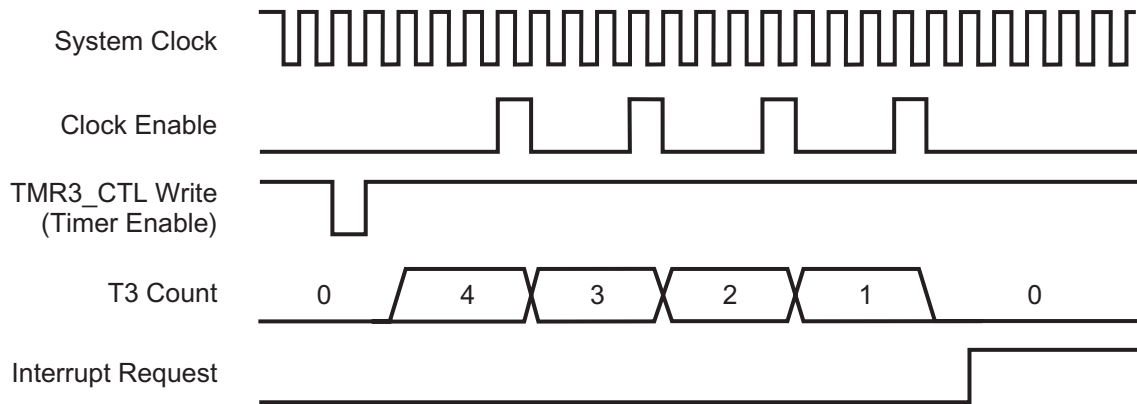

Figure 26. Example: PRT SINGLE PASS Mode Operation

Table 50. Example: PRT SINGLE PASS Mode Parameters

| Parameter | Control Register(s) | Value |
|-------------------------------|------------------------|-------|
| Timer Enable | TMRx_CTL[TIM_EN] | 1 |
| Reload | TMRx_CTL[RLD] | 1 |
| Prescaler Divider = 4 | TMRx_CTL[CLK_DIV] | 00b |
| SINGLE PASS Mode | TMRx_CTL[TIM_CONT] | 0 |
| End of Count Interrupt Enable | TMRx_IER[IRQ_EOC_EN] | 1 |
| Timer Reload Value | {TMRx_RR_H, TMRx_RR_L} | 0004h |

Continuous Mode

In CONTINUOUS mode, when the end-of-count value, 0000h, is reached, the timer automatically reloads the 16-bit start value from the Timer Reload registers, TMRx_RR_H and TMRx_RR_L. Downcounting continues on the next clock edge and the timer continues to count until disabled. An example of the timer operating in CONTINUOUS mode is illustrated in Figure 27. Timer register information is indicated in Table 51.

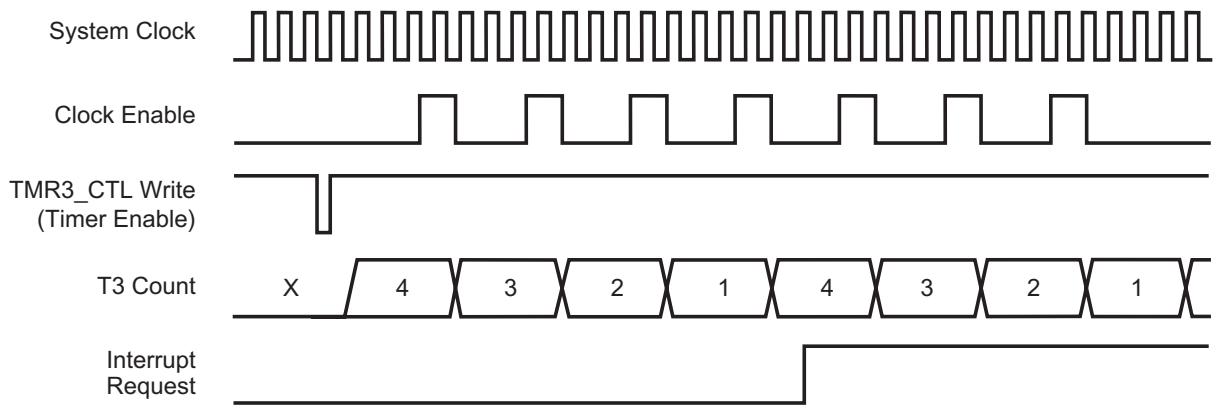

Figure 27. Example: PRT CONTINUOUS Mode Operation

Table 51. Example : PRT CONTINUOUS Mode Parameters

| Parameter | Control Register(s) | Value |
|-------------------------------|------------------------|-------|
| Timer Enable | TMRx_CTL[TIM_EN] | 1 |
| Reload | TMRx_CTL[RLD] | 1 |
| Prescaler Divider = 4 | TMRx_CTL[CLK_DIV] | 00b |
| CONTINUOUS Mode | TMRx_CTL[TIM_CONT] | 1 |
| End of Count Interrupt Enable | TMRx_IER[IRQ_EOC_EN] | 1 |
| Timer Reload Value | {TMRx_RR_H, TMRx_RR_L} | 0004h |

Timer Interrupts

The terminal count flag, TMRx_IIR[EOC], is set to 1 whenever the timer reaches 0000h, its end-of-count value in SINGLE PASS mode, or when the timer reloads the start value in CONTINUOUS mode. The terminal count flag is only set when the timer reaches 0000h (or reloads) from 0001h. The timer interrupt flag is not set

to 1 when the timer is loaded with the value 0000h, which selects the maximum time-out period.

The CPU can be programmed to poll the EOC bit for the time-out event. Alternatively, an interrupt service request signal can be sent to the CPU by setting the TMRx_IER[EOC] bit to 1. Then, when the end-of-count value (0000h) is reached and the EOC bit is set to 1, an interrupt service request signal is passed to the CPU. The interrupt service request signal is deactivated by an CPU Read of the timer interrupt identification register, TMRx_IIR. All bits in that register are reset by the Read.

The response of the CPU to this interrupt service request is a function of the CPU's interrupt enable flag, IEF1. For more information about this flag, refer to the eZ80[®] CPU User Manual (UM0077), which is available on zilog.com.

Timer Input Source Selection

Timers 0–3 feature programmable input source selection. By default, the input is taken from the eZ80F91's system clock. The timers can also use the Real-Time Clock source (50, 60, or 32768Hz) as their clock sources. The input source for these timers is set using the timer control register. (TMRx_CTL[CLK_SEL])

Timer Output

The timer count can be directed to the GPIO output pins if required. To enable the Timer Out feature, the GPIO port pin must be configured as an output and for alternate functions. The GPIO output pin toggles each time the timer reaches its end-of-count value. In CONTINUOUS mode operation, enabling the Timer Output feature results in a Timer Output signal period that is twice the timer time-out period. Examples of the Timer Output operation are illustrated in Figure 28 and Table 52. The initial value for the timer output is zero.

Logic to support timer output exists in all timers, but for the eZ80F91 device, only Timer 0 and 2 route the actual timer output to the pins. Because Timer 3 uses the T_{OUT} pins for PWMxN signals, the timer outputs are not available when using complementary PWM outputs. See [Table 53](#) for details.

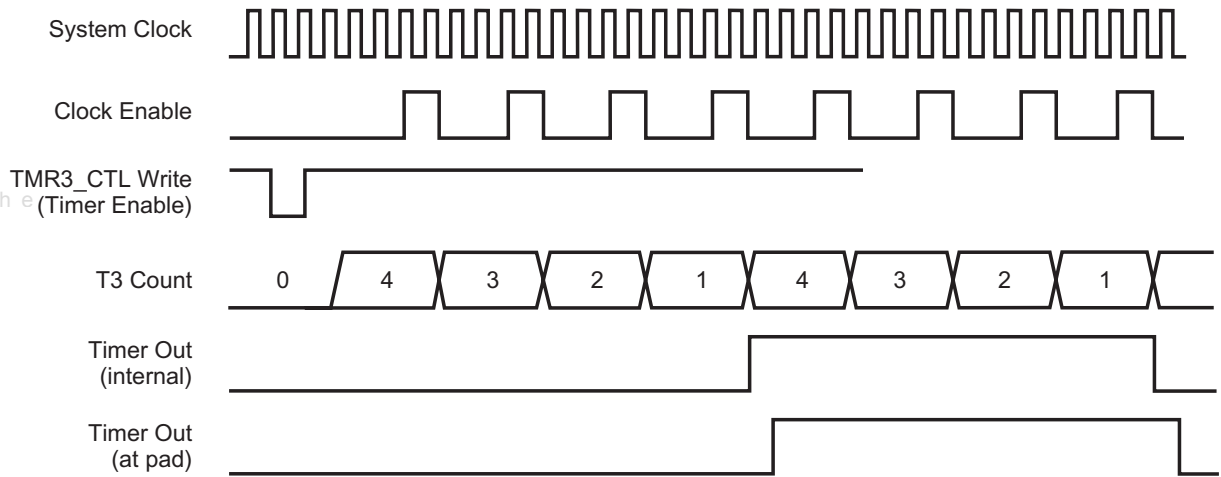

Figure 28. Example: PRT Timer Output Operation

Table 52. Example: PRT Timer Out Parameters

| Parameter | Control Register(s) | Value |
|-----------------------|------------------------|-------|
| Timer Enable | TMRx_CTL[TIM_EN] | 1 |
| Reload | TMRx_CTL[RLD] | 1 |
| Prescaler Divider = 4 | TMRx_CTL[CLK_DIV] | 00b |
| CONTINUOUS Mode | TMRx_CTL[TIM_CONT] | 1 |
| Timer Reload Value | {TMRx_RR_H, TMRx_RR_L} | 0003h |

Break Point Halting

When the eZ80F91 device is running in DEBUG mode, encountering a break point causes all CPU functions to halt. By default, however, the timers keep running. This instance can make debugging timer-related firmware much more difficult. Therefore, the control register contains a BRK_STP bit. Setting this bit causes the count value to be held during debug break points.

Specialty Timer Modes

The features described above are common to all timers in the eZ80F91 device. In addition to these common features, some of the timers have additional functionality. The following is a list of the special features for each timer.

- Timer 0
 - no special functions
- Timer 1
 - 1 event counter (EC0)
 - 2 input captures (IC0 and IC1)
- Timer 2
 - 1 event counter (EC1)
- Timer 3
 - 2 input captures (IC2 and IC3)
 - 4 output compares (OC0, OC1, OC2, and OC3)
 - 4 PWM outputs (PWM0, PWM1, PWM2, and PWM3)

Timer 3 contains three specialty modes. Each of these modes is enabled using bits in their respective control registers (TMR3_CAP_CTL, TMR3_OC_CTL1, TMR3_PWM_CTL1). When PWM mode is enabled, the OUTPUT COMPARE and INPUT CAPTURE modes are not available. This instance is due to address space sharing requirements. However, INPUT CAPTURE and OUTPUT COMPARE modes can run concurrently.

Timers with specialty modes offer multiple ways to generate an interrupt. When the interrupt controller services a timer interrupt, the firmware must read the timer's interrupt identification register (TMRx_IIR) to determine the cause, or causes, for an interrupt request. This register is cleared each time it is read, allowing subsequent events to be identified without interference from prior events.

Event Counter

When a timer is configured to take its input from a port input pin (ECx), it functions as an event counter. For event counting, the clock prescaler is automatically bypassed and edges (events) cause the timer to decrement. The user must select the rising or the falling edge for counting. Also, the port pins must be configured as inputs.

Input sampling on the port pins results in the counter being updated on the third rising edge of the system clock after the edge event occurs at the port pin. Due to the sampling, the frequency of the event input is limited to one-half the system

clock frequency under ideal conditions. In practice, the event frequency must be less than this value, due to duty cycle variation and system clock jitter.

This EVENT COUNT mode is identical to basic timer operation, except for the clock source. Therefore, interrupts are managed in the same manner.

RTC Oscillator Input

When the timer clock source is the Real-Time Clock signal, the timer functions just as it does in EVENT COUNT mode, except that it samples the internal RTC clock rather than the ECx pin.

Input Capture

INPUT CAPTURE mode allows the CPU to determine the timing of specified events on a set of external pins.

A timer intended for use in INPUT CAPTURE mode is set up the same way as in BASIC mode, with one exception. The CPU must also write the TMRx_CAP_CTL register to select the edge on which to capture: rising, falling, or both. When one of these events occurs on an input capture pin, the current 16 bit timer value is latched into the capture value register pair (TMRx_CAP_A or TMRx_CAP_B depending on the IC pin exhibiting the event).

Reading the Low byte of the register pair causes the timer to ignore other capture events on the associated external pin until the High byte is read. This instance prevents a subsequent capture event from overwriting the High byte between the two Reads and generating an invalid capture value. The capture value registers are Read Only.

A capture flag (ICA or ICB) in the TMRx_IIR register is set whenever a capture event occurs. Setting the interrupt identification register bit TMRx_IER[IRQ_ICx_EN] enables the capture event to generate a timer interrupt.

Output Compare

The output compare function reverses the input capture function. Rather than store a timer value when an external event occurs, OUTPUT COMPARE mode waits until the timer reaches a specified value, then generates an external event. Although the same base timer is used, up to four separate external pins can be driven, each with its own compare value.

To use OUTPUT COMPARE mode, the CPU must first configure the basic timer parameters. Then it must load up to four 16-bit compare values into the four TMR3_OCx register pairs. Next, it must load the TMR3_OC_CTL2 register to specify the event that occurs upon comparison. The user can select the following events: SET, CLEAR, and TOGGLE. Finally, the CPU must enable OUTPUT COMPARE mode by asserting TMR3_OC_CTL1[OC_EN].



The initial value for the OCx pins in OUTPUT COMPARE mode is 0 by default. It is possible to initialize this value to 1, or force a value at a later time. Setting the TMR3_OC_CTL2[OCx_MODE] value to 0 forces the OCx pin to the selected state provided by the TMR3_OC_CTL1[OCx_INIT] bits. Regardless of any compare events, the pin stays at the forced value until OCx_MODE is changed. After release, it retains the forced value until modified by an OUTPUT COMPARE event.

Asserting TMR3_OC_CTL1[MAST_MODE] selects MASTER MODE for all OUTPUT COMPARE events, and sets output 0 as the master. As a result, outputs 1, 2, and 3 are caused to disregard output-specific configuration and comparison values and instead mimic the current settings for output 0.

The OCx bits in the TMR3_IIR register are set whenever the corresponding timer compares occur. TMR3_IER[IRQ_OCx_EN] allows the compare event to generate a timer interrupt.

Timer Port Pin Allocation

The eZ80F91 device timers interface to the outside world via Ports A and B. These ports are also used for general purpose I/O as well as other assorted functions. Table 53 lists the timer pins and their respective functions.

Table 53. GPIO Mode Selection When Using Timer Pins

| Port | GPIO Port Bits | GPIO Port Mode | Timer Function | |
|------|----------------|----------------|----------------------|----------------------|
| | | | PWM_CTL1 MPWM_EN = 0 | PWM_CTL1 MPWM_EN = 1 |
| A | PA0 | 7 | OC0 | PWM0 |
| | PA1 | 7 | OC1 | PWM1 |
| | PA2 | 7 | OC2 | PWM2 |
| | PA3 | 7 | OC3 | PWM3 |
| | | | PWM_CTL1 PAIR_EN = 0 | PWM_CTL1 PAIR_EN = 1 |
| | PA4 | 7 | TOUT0 | PWM0 |
| | PA5 | 7 | TOUT1 | PWM1 |
| | PA6 | 7 | EC1 | PWM2 |
| | PA7 | 7 | | PWM3 |

Table 53. GPIO Mode Selection When Using Timer Pins (Continued)

| Port | GPIO Port Bits | GPIO Port Mode | Timer Function | |
|----------|----------------|----------------|-------------------------|-------------------------|
| | | | PWM_CTL1 MPWM_EN = 0 | PWM_CTL1 MPWM_EN = 1 |
| B | PB0 | 7 | IC0/EC0 | |
| | PB1 | 7 | IC1 | |
| | PB4 | 7 | IC2 | |
| | PB5 | 7 | IC3 | |

www.DataSheet4U.com

Timer Registers

The CPU monitors and controls the timer using seven 8-bit registers. These registers are the control register, the interrupt identification register, the interrupt enable register and the reload register pair (High and Low byte). There are also a pair of data registers used to read the current timer count value.

The variable x can be 0, 1, 2, or 3 to represent each of the 4 available timers.

Basic Timer Register Set

Each timer requires a different set of registers for configuration and control. However, all timers contain the following seven registers, each of which is necessary for basic operation:

- Timer Control Register (TMRx_CTL)
- Interrupt Identification Register (TMRx_IIR)
- Interrupt Enable Register (TMRx_IER)
- Timer Data Registers (TMRx_DR_H and TMRx_DR_L)
- Timer Reload Registers (TMRx_RR_H and TMRx_RR_L)

The Timer Data Register is Read Only, while the Timer Reload Register is Write Only. The address space for these two registers is shared.

Register Set for Capture in Timer 1

In addition to the basic register set, Timer 1 uses the following five registers for its INPUT CAPTURE mode:

- Capture Control Register (TMR1_CAP_CTL)
- Capture Value Registers (TMR1_CAP_B_H, TMR1_CAP_B_L, TMR1_CAP_A_H, TMR1_CAP_A_L)

Register Set for Capture/Compare/PWM in Timer 3

In addition to the basic register set, Timer 3 uses 19 registers for INPUT CAPTURE, OUTPUT COMPARE, and PWM modes. PWM and capture/compare functions cannot be used concurrently, so their register address space is shared. INPUT CAPTURE and OUTPUT COMPARE can be used concurrently—their address space is not shared.

The INPUT CAPTURE mode registers are equivalent to those used in Timer 1 above (substitute TMR3 for TMR1).

OUTPUT COMPARE mode uses the following nine registers:

- Output Compare Control Registers
 - TMR3_OC_CTL1
 - TMR3_OC_CTL2
- Compare Value Registers
 - TMR3_OC3_H
 - TMR3_OC3_L
 - TMR3_OC2_H
 - TMR3_OC2_L
 - TMR3_OC1_H
 - TMR3_OC1_L
 - TMR3_OC0_H
 - TMR3_OC0_L

Multiple PWM mode uses the following 19 registers:

- PWM Control Registers
 - TMR3_PWM_CTL1
 - TMR3_PWM_CTL2
 - TMR3_PWM_CTL3
- PWM Rising Edge Values
 - TMR3_PWM3R_H
 - TMR3_PWM3R_L
 - TMR3_PWM2R_H
 - TMR3_PWM2R_L
 - TMR3_PWM1R_H
 - TMRx_PWM1R_L
 - TMR3_PWM0R_H
 - TMR3_PWM0R_L



- PWM Falling Edge Values
 - TMR3_PWM3F_H
 - TMRx_PWM3F_L
 - TMR3_PWM2F_H
 - TMR3_PWM2F_L
 - TMR3_PWM1F_H
 - TMR3_PWM1F_L
 - TMR3_PWM0F_H
 - TMR3_PWM0F_L

www.DataSheet4U.com

Timer Control Register

The Timer x Control Register, detailed in Table 54, is used to control operation of the timer, including enabling the timer, selecting the clock source, selecting the clock divider, selecting between CONTINUOUS and SINGLEPASS modes, and enabling the auto-reload feature.

Table 54. Timer Control Register
(TMR0_CTL = 0060h, TMR1_CTL = 0065h, TMR2_CTL = 006Fh, TMR3_CTL = 0074h)

| Bit | 7 | 6 | 5 | 4 | 3 | 2 | 1 | 0 |
|-------------------|-----|-----|-----|-----|-----|-----|-----|-----|
| Reset | 0 | 0 | 0 | 0 | 0 | 0 | 0 | 0 |
| CPU Access | R/W | R/W | R/W | R/W | R/W | R/W | R/W | R/W |

Note: R = Read only; R/W = Read/Write.

| Bit Position | Value | Description |
|------------------|-------|--|
| 7 | 0 | The timer continues to operate during debug break points. |
| BRK_STOP | 1 | The timer stops operation and holds count value during debug break points. |
| [6:5] CLK_SEL | 00 | Timer source is the system clock divided by the prescaler. |
| | 01 | Timer source is the Real Time Clock Input. |
| | 10 | Timer source is the Event Count (ECx) input—falling edge. For Timer 1 this is EC0. For Timer 2, this is EC1. |
| | 11 | Timer source is the Event Count (ECx) input—rising edge. For Timer 1 this is EC0. For Timer 2, this is EC1. |



| | | |
|------------------|----|--|
| [4:3] CLK_DIV | 00 | System clock divider = 4. |
| | 01 | System clock divider = 16. |
| | 10 | System clock divider = 64. |
| | 11 | System clock divider = 256. |
| 2 TIM_CONT | 0 | The timer operates in SINGLE PASS mode. TIM_EN (bit 0) is reset to 0, and counting stops when the end-of-count value is reached. |
| | 1 | The timer operates in CONTINUOUS mode. The timer reload value is written to the counter when the end-of-count value is reached. |
| 1 RLD | 0 | Reload function is not forced. |
| | 1 | Force reload. When a 1 is written to this bit, the values in the reload registers are loaded into the downcounter. |
| 0 TIM_EN | 0 | The programmable reload timer is disabled. |
| | 1 | The programmable reload timer is enabled. |

Timer Interrupt Enable Register

The Timer x Interrupt Enable Register, detailed in Table 55, is used to control operation of the timer interrupts. Only bits related to functions present in a given timer are active.

Table 55. Timer Interrupt Enable
(TMR0_IER = 0061h, TMR1_IER = 0066h, TMR2_IER = 0070h, TMR3_IER = 0075h)

| Bit | 7 | 6 | 5 | 4 | 3 | 2 | 1 | 0 |
|-------------------|-----|-----|-----|-----|-----|-----|-----|-----|
| Reset | 0 | 0 | 0 | 0 | 0 | 0 | 0 | 0 |
| CPU Access | R/W | R/W | R/W | R/W | R/W | R/W | R/W | R/W |

Note: R = Read only; R/W = Read/Write.

| Bit Position | Value | Description |
|-----------------|-------|--|
| 7 | 0 | Unused. |
| 6 IRQ_OC3_EN | 0 | Interrupt requests for OC3 are disabled (valid only in OUTPUT COMPARE mode). OC operations occur in Timer 3. |
| | 1 | Interrupt requests for OC3 are enabled (valid only in OUTPUT COMPARE mode). OC operations occur in Timer 3. |



| | | |
|-----------------|---|--|
| 5 IRQ_OC2_EN | 0 | Interrupt requests for OC2 are disabled (valid only in OUTPUT COMPARE mode). OC operations occur in Timer 3. |
| | 1 | Interrupt requests for OC2 are enabled (valid only in OUTPUT COMPARE mode). OC operations occur in Timer 3. |
| 4 IRQ_OC1_EN | 0 | Interrupt requests for OC1 are disabled (valid only in OUTPUT COMPARE mode). OC operations occur in Timer 3. |
| | 1 | Interrupt requests for OC1 are enabled (valid only in OUTPUT COMPARE mode). OC operations occur in Timer 3. |
| 3 IRQ_OC0_EN | 0 | Interrupt requests for OC0 are disabled (valid only in OUTPUT COMPARE mode). OC operations occur in Timer 3. |
| | 1 | Interrupt requests for OC0 are enabled (valid only in OUTPUT COMPARE mode). OC operations occur in Timer 3. |
| 2 IRQ_ICB_EN | 0 | Interrupt requests for ICx are disabled (valid only in INPUT CAPTURE mode). Timer 1: the capture pin is IC1. Timer 3: the capture pin is IC3. |
| | 1 | Interrupt requests for ICx are enabled (valid only in INPUT CAPTURE mode). For Timer 1: the capture pin is IC1. For Timer 3: the capture pin is IC3. |
| 1 IRQ_ICA_EN | 0 | Interrupt requests for ICA or PWM power trip are disabled (valid only in INPUT CAPTURE and PWM modes). For Timer 1: the capture pin is IC0. For Timer 3: the capture pin is IC2. |
| | 1 | Interrupt requests for ICA or PWM power trip are enabled (valid only in INPUT CAPTURE and PWM modes). For Timer 1: the capture pin is IC0. For Timer 3: the capture pin is IC2. |
| 0 IRQ_EOC_EN | 0 | Interrupt on end-of-count is disabled. |
| | 1 | Interrupt on end-of-count is enabled. |



Timer Interrupt Identification Register

The Timer x Interrupt Identification Register, detailed in Table 56, is used to flag timer events so that the CPU can determine the cause of a timer interrupt. This register is cleared by a CPU Read.

Table 56. Timer Interrupt Identification Register
(TMR0_IIR = 0062h, TMR1_IIR = 0067h, TMR2_IIR = 0071h, TMR3_IIR = 0076h)

| Bit | 7 | 6 | 5 | 4 | 3 | 2 | 1 | 0 |
|------------|---|---|---|---|---|---|---|---|
| Reset | 0 | 0 | 0 | 0 | 0 | 0 | 0 | 0 |
| CPU Access | R | R | R | R | R | R | R | R |

Note: R = Read only;

| Bit Position | Value | Description |
|--------------|-------|---|
| 7 | 0 | Unused. |
| 6 OC3 | 0 | Output compare, OC3, does not occur. |
| | 1 | Output compare, OC3, occurs. |
| 5 OC3 | 0 | Output compare, OC2, does not occur. |
| | 1 | Output compare, OC2, occurs. |
| 4 OC1 | 0 | Output compare, OC1, does not occur. |
| | 1 | Output compare, OC1, occurs. |
| 3 OC0 | 0 | Output compare, OC0, does not occur. |
| | 1 | Output compare, OC0, occurs. |
| 2 ICB | 0 | Input capture, ICB, does not occur. For Timer 1, the capture pin is IC1. For Timer 3, the capture pin is IC3. |
| | 1 | Input capture, ICB, occurs. For Timer 1, the capture pin is IC1. For Timer 3, the capture pin is IC3. |
| 1 ICA | 0 | Input capture, ICA, or PWM power trip does not occur. For Timer 1, the capture pin is IC0. For Timer 3, the capture pin is IC2. |
| | 1 | Input capture, ICA, or PWM power trip occurs. For Timer 1, the capture pin is IC0. For Timer 3, the capture pin is IC2. |
| 0 EOC | 0 | End-of-count does not occur. |
| | 1 | End-of-count occurs. |



Timer Data Register—Low Byte

The Timer x Data Register—Low Byte returns the Low byte of the current count value of the selected timer. The Timer Data Register—Low Byte, detailed in Table 57, can be read while the timer is in operation. Reading the current count value does not affect timer operation. To read the 16-bit data of the current count value, {TMRx_DR_H[7:0], TMRx_DR_L[7:0]}, first read the Timer Data Register—Low Byte, followed by the Timer Data Register—High Byte. The Timer Data Register—High Byte value is latched into temporary storage when a Read of the Timer Data Register—Low Byte occurs.

This register shares its address with the corresponding timer reload register.

Table 57. Timer Data Register—Low Byte
(TMR0_DR_L = 0063h, TMR1_DR_L = 0068h, TMR2_DR_L = 0072h, TMR3_DR_L = 0077h)

| Bit | 7 | 6 | 5 | 4 | 3 | 2 | 1 | 0 |
|-------------------|---|---|---|---|---|---|---|---|
| Reset | 0 | 0 | 0 | 0 | 0 | 0 | 0 | 0 |
| CPU Access | R | R | R | R | R | R | R | R |

Note: R = Read only.

| Bit Position | Value | Description |
|-------------------|---------|---|
| [7:0] TMR_DR_L | 00h–FFh | These bits represent the Low byte of the 2-byte timer data value, {TMRx_DR_H[7:0], TMRx_DR_L[7:0]}. Bit 7 is bit 7 of the 16-bit timer data value. Bit 0 is bit 0 (lsb) of the 16-bit timer data value. |

Timer Data Register—High Byte

The Timer x Data Register—High Byte returns the High byte of the count value of the selected timer as it existed at the time that the Low byte was read. The Timer Data Register—High Byte, detailed in Table 58, can be read while the timer is in operation. Reading the current count value does not affect timer operation. To read the 16-bit data of the current count value, {TMRx_DR_H[7:0], TMRx_DR_L[7:0]}, first read the Timer Data Register—Low Byte followed by the Timer Data Register—High Byte. The Timer Data Register—High Byte value is latched into temporary storage when a Read of the Timer Data Register—Low Byte occurs.

This register shares its address with the corresponding timer reload register.



Table 58. Timer Data Register—High Byte
(TMR0_DR_H = 0064h, TMR1_DR_H = 0069h, TMR2_DR_H = 0073h,
TMR3_DR_H = 0078h)

| Bit | 7 | 6 | 5 | 4 | 3 | 2 | 1 | 0 |
|-------------------|---|---|---|---|---|---|---|---|
| Reset | 0 | 0 | 0 | 0 | 0 | 0 | 0 | 0 |
| CPU Access | R | R | R | R | R | R | R | R |

Note: R = Read only.

| Bit Position | Value | Description |
|-------------------|---------|---|
| [7:0] TMR_DR_H | 00h–FFh | These bits represent the High byte of the 2-byte timer data value, {TMRx_DR_H[7:0], TMRx_DR_L[7:0]}. Bit 7 is bit 15 (msb) of the 16-bit timer data value. Bit 0 is bit 8 of the 16-bit timer data value. |

Timer Reload Register—Low Byte

The Timer x Reload Register—Low Byte, detailed in Table 59, stores the least-significant byte (LSB) of the 2-byte timer reload value. In CONTINUOUS mode, the timer reload value is reloaded into the timer upon end-of-count. When the reload bit (TMRx_CTL[RLD]) is set to 1 forcing the reload function, the timer reload value is written to the timer on the next rising edge of the clock.

This register shares its address with the corresponding timer data register.

Table 59. Timer Reload Register—Low Byte
(TMR0_RR_L = 0063h, TMR1_RR_L = 0068h, TMR2_RR_L = 0072h,
TMR3_RR_L = 0077h)

| Bit | 7 | 6 | 5 | 4 | 3 | 2 | 1 | 0 |
|-------------------|---|---|---|---|---|---|---|---|
| Reset | 0 | 0 | 0 | 0 | 0 | 0 | 0 | 0 |
| CPU Access | W | W | W | W | W | W | W | W |

Note: W = Write Only.

| Bit Position | Value | Description |
|-------------------|---------|---|
| [7:0] TMR_RR_L | 00h–FFh | These bits represent the Low byte of the 2-byte timer reload value, {TMRx_RR_H[7:0], TMRx_RR_L[7:0]}. Bit 7 is bit 7 of the 16-bit timer reload value. Bit 0 is bit 0 (lsb) of the 16-bit timer reload value. |



Timer Reload Register—High Byte

The Timer x Reload Register—High Byte, detailed in Table 60, stores the most-significant byte (MSB) of the 2-byte timer reload value. In CONTINUOUS mode, the timer reload value is reloaded into the timer upon end-of-count. When the reload bit (TMRx_CTL[RLD]) is set to 1, thereby forcing the reload function, the timer reload value is written to the timer on the next rising edge of the clock.

This register shares its address with the corresponding timer data register.

Table 60. Timer Reload Register—High Byte
(TMR0_RR_H = 0064h, TMR1_RR_H = 0069h, TMR2_RR_H = 0073h, TMR3_RR_H = 0078h)

| Bit | 7 | 6 | 5 | 4 | 3 | 2 | 1 | 0 |
|------------|---|---|---|---|---|---|---|---|
| Reset | 0 | 0 | 0 | 0 | 0 | 0 | 0 | 0 |
| CPU Access | W | W | W | W | W | W | W | W |

Note: W = Write Only.

| Bit Position | Value | Description |
|-------------------|---------|---|
| [7:0] TMR_RR_H | 00h–FFh | These bits represent the High byte of the 2-byte timer reload value, {TMRx_RR_H[7:0], TMRx_RR_L[7:0]}. Bit 7 is bit 15 (msb) of the 16-bit timer reload value. Bit 0 is bit 8 of the 16-bit timer reload value. |

Timer Input Capture Control Register

The Timer x Input Capture Control Register, detailed in Table 61, is used to select the edge or edges to be captured. For Timer 1, CAP_EDGE_B is used for IC1, and CAP_EDGE_A is for IC0. For Timer 3, CAP_EDGE_B is for IC3, and CAP_EDGE_A is for IC2.

Table 61. Timer Input Capture Control Register
(TMR1_CAP_CTL = 006Ah, TMR3_CAP_CTL = 007Bh)

| Bit | 7 | 6 | 5 | 4 | 3 | 2 | 1 | 0 |
|------------|-----|-----|-----|-----|-----|-----|-----|-----|
| Reset | 0 | 0 | 0 | 0 | 0 | 0 | 0 | 0 |
| CPU Access | R/W | R/W | R/W | R/W | R/W | R/W | R/W | R/W |

Note: R = Read only; R/W = Read/Write.

| Bit Position | Value | Description |
|--------------|-------|-------------|
| [7:4] | 0000 | Reserved |



| | | |
|---------------------|----|---|
| [3:2] CAP_EDGE_B | 00 | Disable capture on ICB. |
| | 01 | Enable capture only on the falling edge of ICB. |
| | 10 | Enable capture only on the rising edge of ICB. |
| | 11 | Enable capture on both edges of ICB. |
| [1:0] CAP_EDGE_A | 00 | Disable capture on ICA. |
| | 01 | Enable capture only on the falling edge of ICA. |
| | 10 | Enable capture only on the rising edge of ICA. |
| | 11 | Enable capture on both edges of ICA. |

Timer Input Capture Value A Register—Low Byte

The Timer x Input Capture Value A Register—Low Byte, detailed in Table 62, stores the Low byte of the capture value for external input A. For Timer 1, the external input is IC0. For Timer 3, it is IC2.

Table 62. Timer Input Capture Value Register A—Low Byte
(TMR1_CAPA_L = 006Bh, TMR3_CAPA_L = 007Ch)

| Bit | 7 | 6 | 5 | 4 | 3 | 2 | 1 | 0 |
|-------------------|---|---|---|---|---|---|---|---|
| Reset | 0 | 0 | 0 | 0 | 0 | 0 | 0 | 0 |
| CPU Access | R | R | R | R | R | R | R | R |

Note: R = Read only.

| Bit Position | Value | Description |
|----------------------|---------|--|
| [7:0] TMRx_CAPA_L | 00h–FFh | These bits represent the Low byte of the 2-byte capture value, {TMRx_CAPA_H[7:0], TMRx_CAPA_L[7:0]}. Bit 7 is bit 7 of the 16-bit data value. Bit 0 is bit 0 (lsb) of the 16-bit timer data value. |



Timer Input Capture Value A Register—High Byte

The Timer x Input Capture Value A Register—High Byte, detailed in Table 63, stores the High byte of the capture value for external input A. For Timer 1, the external input is IC0. For Timer 3, it is IC2.

Table 63. Timer Input Capture Value Register A—High Byte
(TMR1_CAPA_H = 006Ch, TMR3_CAPA_H = 007Dh)

| Bit | 7 | 6 | 5 | 4 | 3 | 2 | 1 | 0 |
|------------|---|---|---|---|---|---|---|---|
| Reset | 0 | 0 | 0 | 0 | 0 | 0 | 0 | 0 |
| CPU Access | R | R | R | R | R | R | R | R |

Note: R = Read only.

| Bit Position | Value | Description |
|----------------------|---------|--|
| [7:0] TMRx_CAPA_H | 00h–FFh | These bits represent the High byte of the 2-byte capture value, {TMRx_CAPA_H[7:0], TMRx_CAPA_L[7:0]}. Bit 7 is bit 15 (msb) of the 16-bit data value. Bit 0 is bit 8 of the 16-bit timer data value. |

Timer Input Capture Value B Register—Low Byte

The Timer x Input Capture Value B Register—Low Byte, detailed in Table 64, stores the Low byte of the capture value for external input B. For Timer 1, the external input is IC1. For Timer 3, it is IC3.

Table 64. Timer Input Capture Value Register B—Low Byte
(TMR1_CAPB_L = 006Dh, TMR3_CAPB_L = 007Eh)

| Bit | 7 | 6 | 5 | 4 | 3 | 2 | 1 | 0 |
|------------|---|---|---|---|---|---|---|---|
| Reset | 0 | 0 | 0 | 0 | 0 | 0 | 0 | 0 |
| CPU Access | R | R | R | R | R | R | R | R |

Note: R = Read only.

| Bit Position | Value | Description |
|----------------------|---------|--|
| [7:0] TMRx_CAPB_L | 00h–FFh | These bits represent the Low byte of the 2-byte capture value, {TMRx_CAPB_H[7:0], TMRx_CAPB_L[7:0]}. Bit 7 is bit 7 of the 16-bit data value. Bit 0 is bit 0 (lsb) of the 16-bit timer data value. |



Timer Input Capture Value B Register—High Byte

The Timer x Input Capture Value B Register—High Byte, detailed in Table 65, stores the High byte of the capture value for external input B. For Timer 1, the external input is IC0. For Timer 3, it is IC3.

Table 65. Timer Input Capture Value Register B—High Byte
(TMR1_CAPB_H = 006Eh, TMR3_CAPB_H = 007Fh)

| Bit | 7 | 6 | 5 | 4 | 3 | 2 | 1 | 0 |
|-------------------|---|---|---|---|---|---|---|---|
| Reset | 0 | 0 | 0 | 0 | 0 | 0 | 0 | 0 |
| CPU Access | R | R | R | R | R | R | R | R |

Note: R = Read only.

| Bit Position | Value | Description |
|----------------------|---------|--|
| [7:0] TMRx_CAPB_H | 00h–FFh | These bits represent the High byte of the 2-byte capture value, {TMRx_CAPB_H[7:0], TMRx_CAPB_L[7:0]}. Bit 7 is bit 15 (msb) of the 16-bit data value. Bit 0 is bit 8 of the 16-bit timer data value. |

Timer Output Compare Control Register 1

The Timer3 Output Compare Control Register 1, detailed in Table 66, is used to select the Master Mode and to provide initial values for the OC pins.

Table 66. Timer Output Compare Control Register 1
(TMR3_OC_CTL1 = 0080h)

| Bit | 7 | 6 | 5 | 4 | 3 | 2 | 1 | 0 |
|-------------------|-----|-----|-----|-----|-----|-----|-----|-----|
| Reset | 0 | 0 | 0 | 0 | 0 | 0 | 0 | 0 |
| CPU Access | R/W | R/W | R/W | R/W | R/W | R/W | R/W | R/W |

Note: R = Read only; R/W = Read/Write.

| Bit Position | Value | Description |
|---------------|-------|----------------------------------|
| [7:6] | 00 | Unused |
| 5 OC3_INIT | 0 | OC pin cleared when initialized. |
| | 1 | OC pin set when initialized. |
| 4 OC2_INIT | 0 | OC pin cleared when initialized. |
| | 1 | OC pin set when initialized. |

| | | |
|----------------|---|----------------------------------|
| 3 OC1_INIT | 0 | OC pin cleared when initialized. |
| | 1 | OC pin set when initialized. |
| 2 OC0_INIT | 0 | OC pin cleared when initialized. |
| | 1 | OC pin set when initialized. |
| 1 MAST_MODE | 0 | OC pins are independent. |
| | 1 | OC pins all mimic OC0. |
| 0 OC_EN | 0 | OUTPUT COMPARE mode is disabled. |
| | 1 | OUTPUT COMPARE mode is enabled. |

Timer Output Compare Control Register 2

The Timer3 Output Compare Control Register 2, detailed in Table 67, is used to select the event that will occur on the output compare pins when a timer compare happens.

**Table 67. Timer Output Compare Control Register 2
(TMR3_OC_CTL2 = 0081h)**

| Bit | 7 | 6 | 5 | 4 | 3 | 2 | 1 | 0 |
|-------------------|-----|-----|-----|-----|-----|-----|-----|-----|
| Reset | 0 | 0 | 0 | 0 | 0 | 0 | 0 | 0 |
| CPU Access | R/W | R/W | R/W | R/W | R/W | R/W | R/W | R/W |

Note: R/W = Read/Write.

| Bit Position | Value | Description |
|-------------------|-------|--|
| [7:6] OC3_MODE | 00 | Initialize OC pin to value specified in TMR3_OC_CTL1[OC3_INT]. |
| | 01 | OC pin is cleared upon timer compare. |
| | 10 | OC pin is set upon timer compare. |
| | 11 | OC pin toggles upon timer compare. |
| [5:4] OC2_MODE | 00 | Initialize OC pin to value specified in TMR3_OC_CTL1[OC2_INT]. |
| | 01 | OC pin is cleared upon timer compare. |
| | 10 | OC pin is set upon timer compare. |
| | 11 | OC pin toggles upon timer compare. |



| | | |
|-------------------|----|--|
| [3:2] OC1_MODE | 00 | Initialize OC pin to value specified in TMR3_OC_CTL1[OC1_INT]. |
| | 01 | OC pin is cleared upon timer compare. |
| | 10 | OC pin is set upon timer compare. |
| | 11 | OC pin toggles upon timer compare. |
| [1:0] OC0_MODE | 00 | Initialize OC pin to value specified in TMR3_OC_CTL1[OC0_INT]. |
| | 01 | OC pin is cleared upon timer compare. |
| | 10 | OC pin is set upon timer compare. |
| | 11 | OC pin toggles upon timer compare. |

Timer Output Compare Value Register—Low Byte

The Timer3 Output Compare x Value Register—Low Byte, detailed in Table 68, stores the Low byte of the compare value for OC0–OC3.

Table 68. Compare Value Register—Low Byte
(TMR3_OC0_L = 0082h, TMR3_OC1_L = 0084h,
TMR3_OC2_L = 0086h, TMR3_OC3_L = 0088h)

| Bit | 7 | 6 | 5 | 4 | 3 | 2 | 1 | 0 |
|-------------------|-----|-----|-----|-----|-----|-----|-----|-----|
| Reset | 0 | 0 | 0 | 0 | 0 | 0 | 0 | 0 |
| CPU Access | R/W | R/W | R/W | R/W | R/W | R/W | R/W | R/W |

Note: R/W = Read/Write.

| Bit Position | Value | Description |
|---------------------|---------|---|
| [7:0] TMR3_OCx_L | 00h–FFh | These bits represent the Low byte of the 2-byte compare value, {TMR3_OCx_H[7:0], TMR3_OCx_L[7:0]}. Bit 7 is bit 7 of the 16-bit data value. Bit 0 is bit 0 (lsb) of the 16-bit timer compare value. |



Timer Output Compare Value Register—High Byte

The Timer3 Output Compare x Value Register—High Byte, detailed in Table 69, stores the High byte of the compare value for OC0–OC3.

Table 69. Compare Value Register—High Byte
(TMR3_OC0_H = 0083h, TMR3_OC1_H = 0085h,
TMR3_OC2_H = 0087h, TMR3_OC3_H = 0089h)

| Bit | 7 | 6 | 5 | 4 | 3 | 2 | 1 | 0 |
|-------------------|-----|-----|-----|-----|-----|-----|-----|-----|
| Reset | 0 | 0 | 0 | 0 | 0 | 0 | 0 | 0 |
| CPU Access | R/W | R/W | R/W | R/W | R/W | R/W | R/W | R/W |

Note: R/W = Read/Write.

| Bit Position | Value | Description |
|---------------------|---------|---|
| [7:0] TMR3_OCx_H | 00h–FFh | These bits represent the High byte of the 2-byte compare value, {TMR3_OCx_H[7:0], TMR3_OCx_L[7:0]}. Bit 7 is bit 15 (msb) of the 16-bit data value. Bit 0 is bit 8 of the 16-bit timer compare value. |

Multi-PWM Mode

Multi-PWM Mode Overview

The special Multi-PWM mode uses the Timer 3 16-bit counter as the primary time-keeper to control up to 4 pulse-width modulated (PWM) generators. The 16-bit reload value for Timer 3 sets a common period for each of the PWM signals. However, the duty cycle and phase for each generator are independent—that is, the High and Low periods for each PWM generator are set independently. In addition, each of the 4 PWM generators is enabled independently. The 8 PWM signals (4 PWM output signals and their inverses) are output via Port A. A functional block diagram of the Multi-PWM is illustrated in Figure 29.

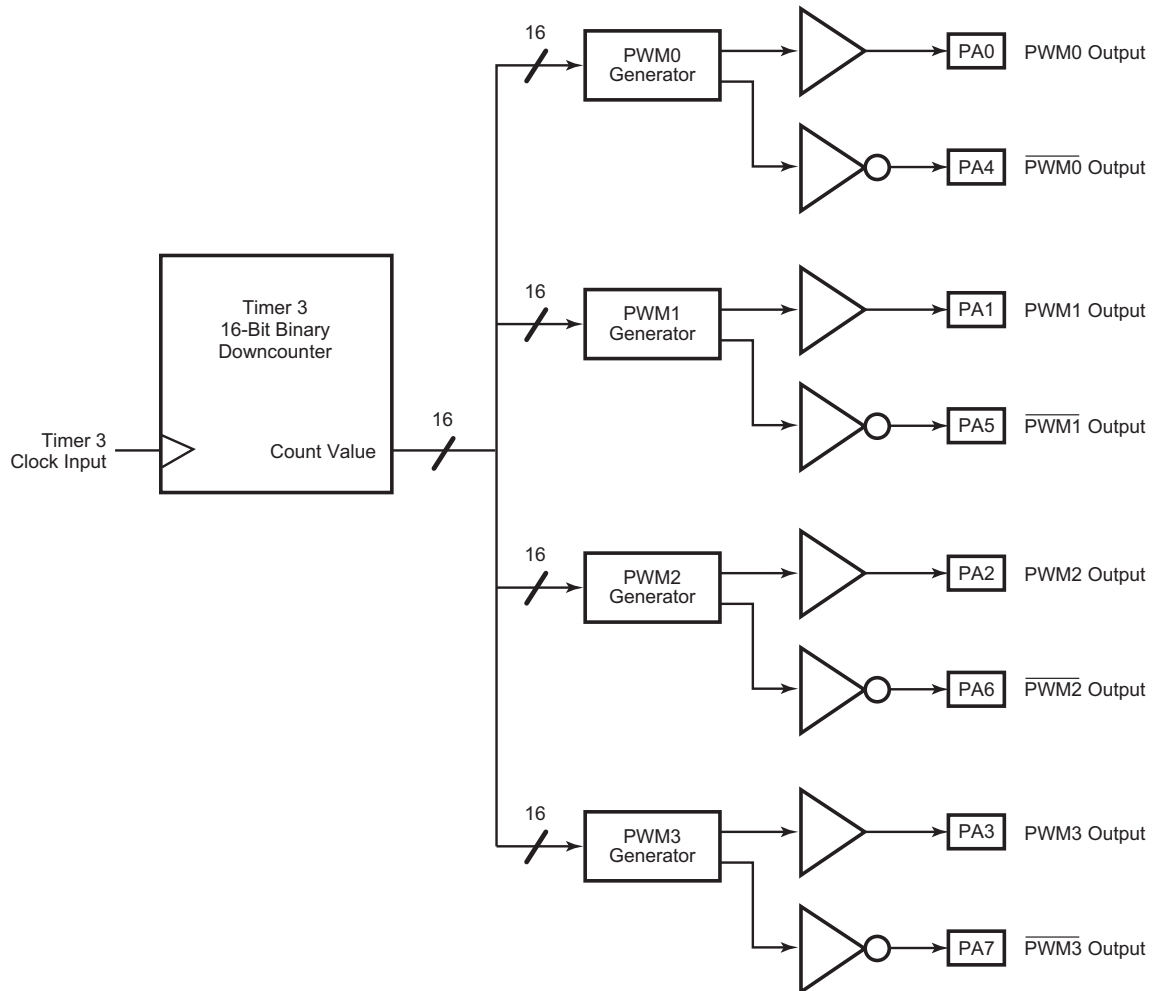

Figure 29. Multi-PWM Simplified Block Diagram

Setting TMR3_PWM_CTL1[MPWM_EN] to 1 enables Multi-PWM mode. The TMR3_PWM_CTL1 register bits enable the 4 individual PWM generators by adjusting settings according to the list provided in Table 70.

Table 70. Enabling PWM Generators

| |
|--|
| Enable PWM generator 0 by setting TMR3_PWM_CTL1[PWM0_EN] to 1. |
| Enable PWM generator 1 by setting TMR3_PWM_CTL1[PWM1_EN] to 1. |
| Enable PWM generator 2 by setting TMR3_PWM_CTL1[PWM2_EN] to 1. |
| Enable PWM generator 3 by setting TMR3_PWM_CTL1[PWM3_EN] to 1. |

The inverted PWM outputs $\overline{\text{PWM0}}$, $\overline{\text{PWM1}}$, $\overline{\text{PWM2}}$, and $\overline{\text{PWM3}}$ are globally enabled by setting TMR3_PWM_CTL1[PAIR_EN] to 1. The individual PWM generators must be enabled for the associated inverted PWM signals to be output.

For each of the 4 PWM generators, there is a 16-bit rising edge value {TMR3_PWMxR_H[PWMxR_H], TMR3_PWMxR_L[PWMxR_L]} and a 16-bit falling edge value {TMR3_PWMxF_H[PWMxF_H], TMR3_PWMxF_L[PWMxF_L]} for a total of 16 registers. The rising-edge byte pairs define the timer count at which the PWMx output transitions from Low to High. Conversely, the falling-edge byte pairs define the timer count at which the PWMx output transitions from High to Low. Upon reset, all enabled PWM outputs begin Low and all PWMx outputs begin High. When the PWMx output is Low, the logic is looking for a match between the timer count and the rising edge value, and vice versa. Therefore, in a case in which the rising edge value is the same as the falling edge value, the PWM output frequency is one-half the rate at which the counter passes through its entire count cycle (from reload value down to 0000h).

Figures 30 and 31 demonstrate a simple multi-PWM output and an expanded view of the timing, respectively. Associated control values are listed in Table 71.

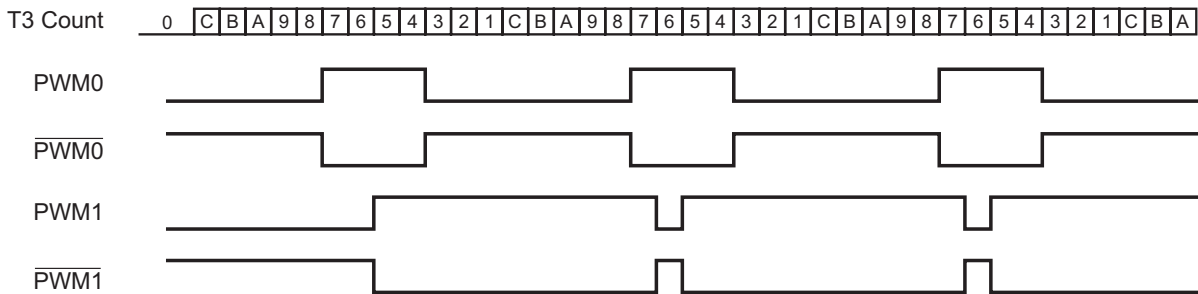

Figure 30. Multi-PWM Operation

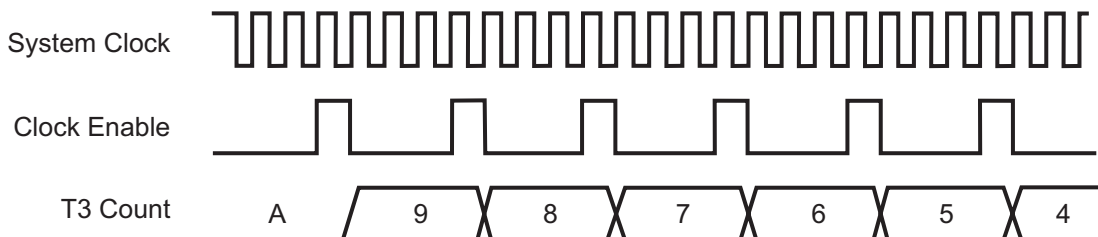

Figure 31. Multi-PWM Operation—Expanded View of Timing



Table 71. Example: Multi-PWM Addressing

| Parameter | Control Register(s) | Value |
|------------------------------|---------------------------------|-------|
| Timer Reload Value | {TMR3_RR_H, TMR3_RR_L} | 000Ch |
| PWM0 rising edge | {TMR3_PWM0R_H, TMR3_PWM0R_L} | 0008h |
| PWM0 falling edge | {TMR3_PWM0F_H, TMR3_PWM0F_L} | 0004h |
| PWM1 rising edge | {TMR3_PWM1R_H, TMR3_PWM1R_L} | 0006h |
| PWM1 falling edge | {TMR3_PWM1F_H, TMR3_PWM1F_L} | 0007h |
| PWM enable | TMR3_PWM_CTL1[PAIR_EN] | 1 |
| PWM0 enable | TMR3_PWM_CTL1[PWM0_EN] | 1 |
| PWM1 enable | TMR3_PWM_CTL1[PWM1_EN] | 1 |
| Multi-PWM enable | TMR3_PWM_CTL1[MPWM_EN] | 1 |
| Prescaler Divider = 4 | TMR3_CTL[CLK_DIV] | 00b |
| PWM nonoverlapping delay = 0 | TMR3_PWM_CTL2[PWM_DLY] | 0000b |

PWM Master Mode

In PWM Master mode, the pair of output signals generated from the PWM0 generator (PWM0 and PWM0) are directed to all four sets of PWM output pairs. Setting TMR3_PWM_CTL1[MM_EN] to 1 enables PWM Master mode. Assuming the outputs are all enabled and no AND/OR gating is used, all four PWM output pairs transition simultaneously under the direction of PWM0 and PWM0. In PWM Master mode, the outputs can still be gated individually using the AND/OR gating functions described in the next section. Multi-PWM mode and the individual PWM outputs must be enabled along with PWM Master mode. It is possible to enable or disable any combination of the 4 PWM outputs while running in PWM Master mode.

Modification of Edge Transition Values

Special circuitry is included for the update of the PWM edge transition values. Normal use requires that these values be updated while the PWM generator is running.

- **Note:** Under certain circumstances, electric motors driven by the PWM logic can encounter rough operation. In essence, cycles can be skipped if the PWM waveform edge is not carefully modified.

Without special consideration, if a PWM generator looks for a particular count to make a state transition, and if the edge transition value changes to a value that already occurred in the current counter count-down cycle, then the transition is missed. The PWM generator holds the current output state until the counter reloads and cycles through to the appropriate edge transition value again. In effect, an entire cycle of the PWM waveform can be skipped with the signal held at a DC value. The change in PWM waveform duty cycle from cycle to cycle must be limited to some fraction of a period to avoid rough running. To avoid unintentional roughness due to timing of the load operation for the register values in question, the PWM edge transition values are double-buffered and exhibit the following behavior:

1. When the PWM generators are disabled, PWM edge transition values written by the CPU are immediately loaded into the PWM edge transition registers.
2. When the PWM generators are enabled, a PWM edge transition value is loaded into a buffer register and transferred to its destination register only upon a specific transition event. A rising edge transition value is only loaded upon a falling edge transition event, and a falling edge transition value is only loaded upon a rising edge transition event.

AND/OR Gating of the PWM Outputs

When in Multi-PWM mode, it is possible for the user to turn off PWM propagation to the pins without disabling the PWM generator. This feature is global and applies to all enabled PWM generators. The function is implemented by applying digital logic (AND or OR functions) to combine the corresponding bits in the port output register with the PWM and PWM outputs.

The AND or OR functions are enabled on all PWM outputs by setting TMR3_PWM_CTL2[AO_EN] to either a 01b (AND) or 10b (OR). Any other value disables this feature. Likewise, the AND or OR functions are enabled on all PWM outputs by setting TMR3_PWM_CTL2[AON_EN] to either a 01b (AND) or 10b (OR). Any other value disables this feature. A functional block diagram for the AND/OR gating feature for PWM0 and PWM0 is illustrated in Figure 32. The functionality for the other three PWM pairs is identical.

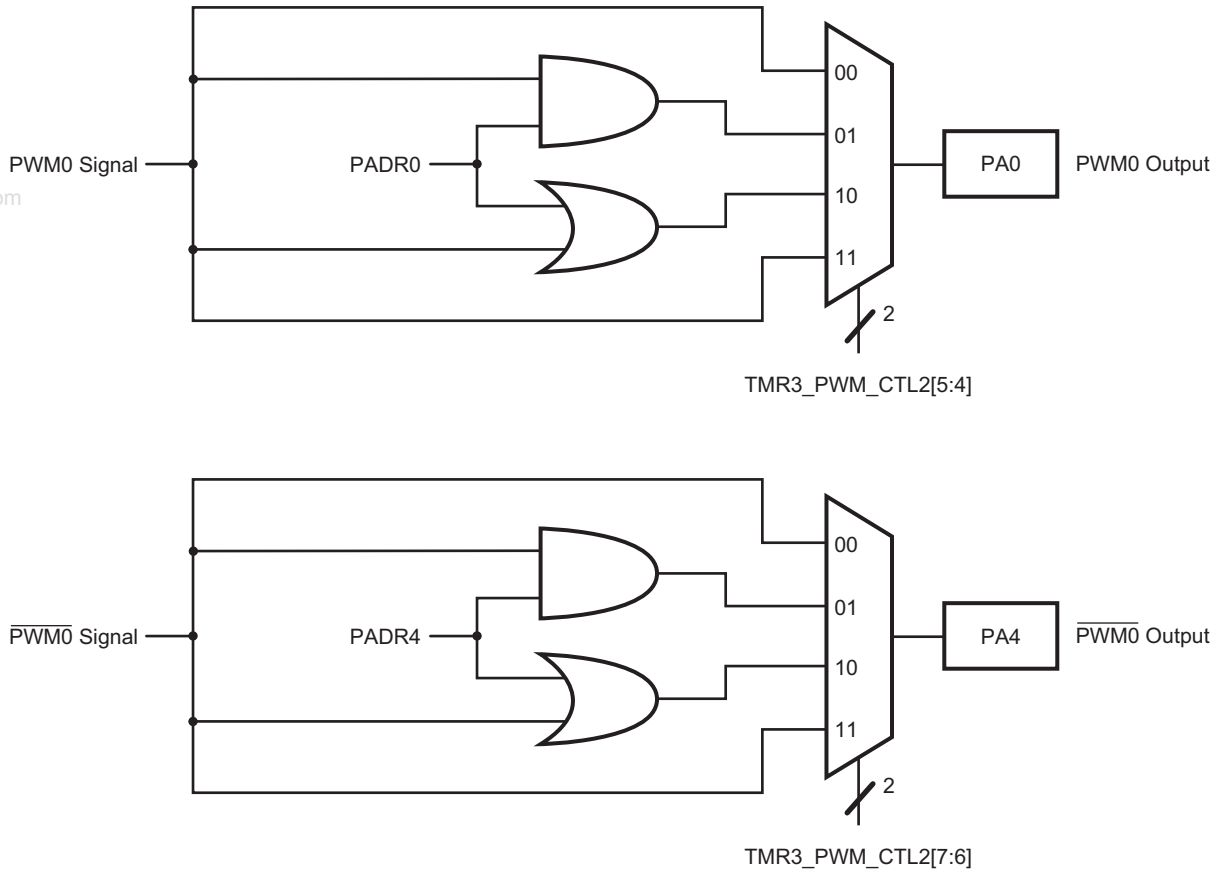

Figure 32. PWM AND/OR Gating Functional Diagram

If the user enables the OR function on all PWM outputs and PADR0 is set to 1, then the PWM0 output on PA0 is forced High. Similarly, if the user selects the AND function on all PWM outputs and PADR0 is set to a 0, then the PWM0 output on PA0 is forced Low.

PWM Nonoverlapping Output Pair Delays

A delay can be added between the falling edge of the PWM (PWM) outputs and the rising edge of the PWM (PWM) outputs. This delay can be set to assure that even with load and output drive variations there will be no overlap between the falling edge of a PWM (PWM) output and the rising edge of its paired output. The selected delay is global to all four PWM pairs. The delay duration is software-selectable using the 4-bit field TMR3_PWM_CTL2[PWM_DLY]. The duration is programmable in units of the system clock (SCLK), from 0 SCLK periods to 15 SCLK periods. The TMR3_PWM_CTL2[PWM_DLY] bits are mapped directly to a

counter, such that a setting of 0000b represents a delay of 0 system clock periods, and a setting of 1111b represents a delay of 15 system clock periods. The PWM delay feature is illustrated in Figure 33, with associated addressing listed in Table 72.

- **Note:** The PWM nonoverlapping delay time must always be defined to be less than the delay between the rising and falling edges (and the delay between the falling and rising edges) of all Multi-PWM outputs. In other words, a rising (falling) edge cannot be delayed beyond the time at which it is subsequently scheduled to fall (rise).

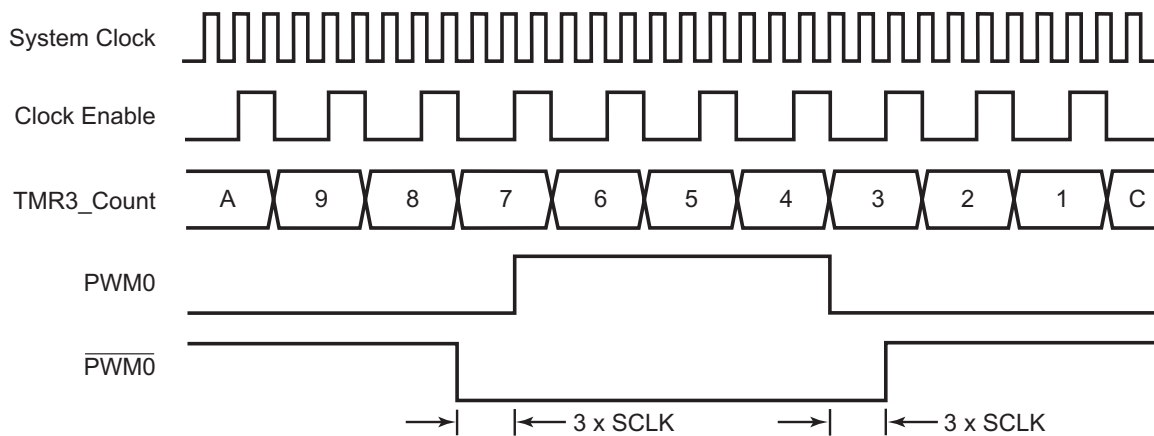

Figure 33. PWM Nonoverlapping Output Delay

Table 72. PWM Nonoverlapping Output Addressing

| Parameter | Control Register(s) | Value |
|------------------------------|------------------------------|-------|
| Timer clock is SCLK ÷ 4 | TMR3_CTL[CLK_DIV] | 00b |
| Timer reload value | {TMR3_RR_H, TMR3_RR_L} | 000Ch |
| PWM0 rising edge | {TMR3_PWM0R_H, TMR3_PWM0R_L} | 0008h |
| PWM0 falling edge | {TMR3_PWM0F_H, TMR3_PWM0F_L} | 0004h |
| Prescaler divider = 4 | TMR3_CTL[CLK_DIV] | 00b |
| PWM nonoverlapping delay = 3 | TMR3_PWM_CTL2[PWM_DLY] | 0011b |
| PWM enable | TMR3_PWM_CTL1[PAIR_EN] | 1 |
| PWM0 enable | TMR3_PWM_CTL1[PWM0_EN] | 1 |
| Multi-PWM enable | TMR3_PWM_CTL1[MPWN_EN] | 1 |

Multi-PWM Power-Trip Mode

When enabled, the Multi-PWM power-trip feature forces the enabled PWM outputs to a predetermined state when an interrupt is generated from an external source via IC0, IC1, IC2, or IC3. One or multiple external interrupt sources can be enabled at any given time. If multiple sources are enabled, any of the selected external sources can trigger an interrupt. Configuring the PWM_CTL3 register enables or disables interrupt sources. See [Table 75](#) on page 161.

The possible interrupt sources for a Multi-PWM power-trip are:

- IC0—digital input
- IC1—digital input
- IC2—digital input
- IC3—digital input

When the power trip is detected, TMR3_PWM_CTL3[PTD] is set to 1 to indicate detection of the power-trip. A value of 0 signifies that no power-trip is detected.

The PWMs can only be released after a power-trip when TMR3_PWM_CTL3[PTD] is written back to 0 by software. As a result, the user is allowed to check the conditions of the motor being controlled before releasing the PWMs. The explicit release also prevents noise glitches after a power-trip from causing an accidental exit or reentry of the PWM power-trip state.

The programmable power-trip states of the PWMs are globally grouped for the PWM outputs and the inverting PWM outputs. Upon detection of a power-trip, the PWM outputs can be forced to either a High state, a Low state, or tristate. The settings for the power-trip states are made with power-trip control bits TMR3_PWM_CTL3[PT_LVL], TMR3_PWM_CTL3[PT_LVL_N], and TMR3_PWM_CTL3[PT_TRI].



Multi-PWM Control Registers

Pulse-Width Modulation Control Register 1

The PWM Control Register 1, detailed in Table 73, controls PWM function enables.

**Table 73. PWM Control Register 1
(PWM_CTL1 = 0079h)**

| Bit | 7 | 6 | 5 | 4 | 3 | 2 | 1 | 0 |
|-------------------|-----|-----|-----|-----|-----|-----|-----|-----|
| Reset | 0 | 0 | 0 | 0 | 0 | 0 | 0 | 0 |
| CPU Access | R/W | R/W | R/W | R/W | R/W | R/W | R/W | R/W |

Note: R/W = Read/Write.

| Bit Position | Value | Description |
|--------------|-------|---|
| 7 PAIR_EN | 0 | Global disable of the PWM outputs (PWM outputs enabled only). |
| | 1 | Global enable of the PWM and PWM output pairs. |
| 6 PT_EN | 0 | Disable power-trip feature. |
| | 1 | Enable power-trip feature. |
| 5 MM_EN | 0 | Disable Master mode. |
| | 1 | Enable Master mode. |
| 4 PWM3_EN | 0 | Disable PWM generator 3. |
| | 1 | Enable PWM generator 3. |
| 3 PWM2_EN | 0 | Disable PWM generator 2. |
| | 1 | Enable PWM generator 2. |
| 2 PWM1_EN | 0 | Disable PWM generator 1. |
| | 1 | Enable PWM generator 1. |
| 1 PWM0_EN | 0 | Disable PWM generator 0. |
| | 1 | Enable PWM generator 0. |
| 0 MPWM_EN | 0 | Disable Multi-PWM mode. |
| | 1 | Enable Multi-PWM mode. |



Pulse-Width Modulation Control Register 2

The PWM Control Register 2, detailed in Table 74, controls PWM AND/OR and edge delay functions.

Table 74. PWM Control Register 2
(PWM_CTL2 = 007Ah)

| Bit | 7 | 6 | 5 | 4 | 3 | 2 | 1 | 0 |
|-------------------|-----|-----|-----|-----|-----|-----|-----|-----|
| Reset | 0 | 0 | 0 | 0 | 0 | 0 | 0 | 0 |
| CPU Access | R/W | R/W | R/W | R/W | R/W | R/W | R/W | R/W |

Note: R/W = Read/Write.

| Bit Position | Value | Description |
|-----------------|-------|---------------------------------|
| [7:6] AON_EN | 00 | Disable AND/OR features on PWM. |
| | 01 | Enable AND logic on PWM. |
| | 10 | Enable OR logic on PWM. |
| | 11 | Disable AND/OR features on PWM. |
| [5:4] AO_EN | 00 | Disable AND/OR features on PWM. |
| | 01 | Enable AND logic on PWM. |
| | 10 | Enable OR logic on PWM. |
| | 11 | Disable AND/OR features on PWM. |



| | | |
|------------------|--|--|
| [3:0] PWM_DLY | 0000 | No delay <u>between</u> falling edge of PWM (PWM) and rising edge of PWM (PWM) |
| | 0001 | Delay of 1 SCLK periods <u>between</u> falling edge of PWM (PWM) and rising edge of PWM (PWM) |
| | 0010 | Delay of 2 SCLK periods <u>between</u> falling edge of PWM (PWM) and rising edge of PWM (PWM) |
| | 0011 | Delay of 3 SCLK periods <u>between</u> falling edge of PWM (PWM) and rising edge of PWM (PWM) |
| | 0100 | Delay of 4 SCLK periods <u>between</u> falling edge of PWM (PWM) and rising edge of PWM (PWM) |
| | 0101 | Delay of 5 SCLK periods <u>between</u> falling edge of PWM (PWM) and rising edge of PWM (PWM) |
| | 0110 | Delay of 6 SCLK periods <u>between</u> falling edge of PWM (PWM) and rising edge of PWM (PWM) |
| | 0111 | Delay of 7 SCLK periods <u>between</u> falling edge of PWM (PWM) and rising edge of PWM (PWM) |
| | 1000 | Delay of 8 SCLK periods <u>between</u> falling edge of PWM (PWM) and rising edge of PWM (PWM) |
| | 1001 | Delay of 9 SCLK periods <u>between</u> falling edge of PWM (PWM) and rising edge of PWM (PWM) |
| | 1010 | Delay of 10 SCLK periods <u>between</u> falling edge of PWM (PWM) and rising edge of PWM (PWM) |
| | 1011 | Delay of 11 SCLK periods <u>between</u> falling edge of PWM (PWM) and rising edge of PWM (PWM) |
| | 1100 | Delay of 12 SCLK periods <u>between</u> falling edge of PWM (PWM) and rising edge of PWM (PWM) |
| | 1101 | Delay of 13 SCLK periods <u>between</u> falling edge of PWM (PWM) and rising edge of PWM (PWM) |
| | 1110 | Delay of 14 SCLK periods <u>between</u> falling edge of PWM (PWM) and rising edge of PWM (PWM) |
| 1111 | Delay of 15 SCLK periods <u>between</u> falling edge of PWM (PWM) and rising edge of PWM (PWM) | |

www.DataSheet4U.com



Pulse-Width Modulation Control Register 3

The PWM Control Register 3, detailed in Table 75, is used to configure the PWM power trip functionality.

**Table 75. PWM Control Register 3
(PWM_CTL3 = 007Bh)**

| Bit | 7 | 6 | 5 | 4 | 3 | 2 | 1 | 0 |
|-------------------|-----|-----|-----|-----|-----|-----|-----|---|
| Reset | 0 | 0 | 0 | 0 | 0 | 0 | 0 | 0 |
| CPU Access | R/W | R/W | R/W | R/W | R/W | R/W | R/W | R |

Note: R/W = Read/Write; R = Read only;

| Bit Position | Value | Description |
|----------------|-------|--|
| 7 PT_IC3_EN | 0 | Power trip disabled on IC3. |
| | 1 | Power trip enabled on IC3. |
| 6 PT_IC2_EN | 0 | Power trip disabled on IC2. |
| | 1 | Power trip enabled on IC2. |
| 5 PT_IC1_EN | 0 | Power trip disabled on IC1. |
| | 1 | Power trip enabled on IC1. |
| 4 PT_IC0_EN | 0 | Power trip disabled on IC0. |
| | 1 | Power trip enabled on IC0. |
| 3 PT_TRI | 0 | All PWM trip levels are tristate |
| | 1 | All PWM trip levels are defined by PT_LVL and PT_LVL_N |
| 2 PT_LVL | 0 | After power trip, PWMx outputs are set to one. |
| | 1 | After power trip, PWMx outputs are set to zero. |
| 1 PT_LVL_N | 0 | After power trip, PWMx outputs are set to one. |
| | 1 | After power trip, PWMx outputs are set to zero. |
| 0 PTD | 0 | Power trip has been cleared. |
| | 1 | This bit is set after power trip event. |



Pulse-Width Modulation Rising Edge—Low Byte

A parallel 16-bit Write of {TMR3_PWMxR_H[7-0], TMR3_PWMxR_L[7-0]} occurs when software initiates a Write to TMR3_PWMxR_L. The register is detailed in Table 76.

Table 76. PWMx Rising-Edge Register—Low Byte
(TMR3_PWM0R_L = 007Ch, TMR3_PWM1R_L = 007Eh, TMR3_PWM2R_L = 0080h, TMR3_PWM3R_L = 0082h)

| Bit | 7 | 6 | 5 | 4 | 3 | 2 | 1 | 0 |
|------------|-----|-----|-----|-----|-----|-----|-----|-----|
| Reset | 0 | 0 | 0 | 0 | 0 | 0 | 0 | 0 |
| CPU Access | R/W | R/W | R/W | R/W | R/W | R/W | R/W | R/W |

Note: R/W = Read/Write.

| Bit Position | Value | Description |
|------------------|---------|--|
| [7:0] PWMXR_L | 00h–FFh | These bits represent the Low byte of the 16-bit value to set the rising edge COMPARE value for PWMx, {TMR3_PWMXR_H[7:0], TMR3_PWMXR_L[7:0]}. Bit 7 is bit 7 of the 16-bit timer data value. Bit 0 is bit 0 (lsb) of the 16-bit timer data value. |



Pulse-Width Modulation Rising Edge—High Byte

Writing to TMR3_PWMxR_H stores the value in a temporary holding register. A parallel 16-bit Write of {TMR3_PWMxR_H[7–0], TMR3_PWMxR_L[7–0]} occurs when software initiates a Write to TMR3_PWMxR_L. The register is detailed in Table 77.

Table 77. PWMx Rising-Edge Register—High Byte
(TMR3_PWM0R_H = 007Dh, TMR3_PWM1R_H = 007Fh, TMR3_PWM2R_H = 0081h, TMR3_PWM3R_H = 0083h)

| Bit | 7 | 6 | 5 | 4 | 3 | 2 | 1 | 0 |
|-------------------|-----|-----|-----|-----|-----|-----|-----|-----|
| Reset | 0 | 0 | 0 | 0 | 0 | 0 | 0 | 0 |
| CPU Access | R/W | R/W | R/W | R/W | R/W | R/W | R/W | R/W |

Note: R/W = Read/Write.

| Bit Position | Value | Description |
|------------------|---------|--|
| [7:0] PWMXR_H | 00h–FFh | These bits represent the High byte of the 16-bit value to set the rising edge COMPARE value for PWMx, {TMR3_PWMXR_H[7:0], TMR3_PWMXR_L[7:0]}. Bit 7 is bit 15 (msb) of the 16-bit timer data value. Bit 0 is bit 8 of the 16-bit timer data value. |



Pulse-Width Modulation Falling Edge—Low Byte

A parallel 16-bit Write of {TMR3_PWMxF_H[7–0], TMR3_PWMxF_L[7–0]} occurs when software initiates a Write to TMR3_PWMxF_L. The register is detailed in Table 78.

Table 78. PWMx Falling-Edge Register—Low Byte
(TMR3_PWM0F_L = 0084h, TMR3_PWM1F_L = 0086h, TMR3_PWM2F_L = 0088h, TMR3_PWM3F_L = 008Ah)

| Bit | 7 | 6 | 5 | 4 | 3 | 2 | 1 | 0 |
|-------------------|-----|-----|-----|-----|-----|-----|-----|-----|
| Reset | 0 | 0 | 0 | 0 | 0 | 0 | 0 | 0 |
| CPU Access | R/W | R/W | R/W | R/W | R/W | R/W | R/W | R/W |

Note: R/W = Read/Write.

| Bit Position | Value | Description |
|------------------|---------|---|
| [7:0] PWMXF_L | 00h–FFh | These bits represent the Low byte of the 16-bit value to set the falling edge COMPARE value for PWMx, {TMR3_PWMXF_H[7:0], TMR3_PWMXF_L[7:0]}. Bit 7 is bit 7 of the 16-bit timer data value. Bit 0 is bit 0 (lsb) of the 16-bit timer data value. |



Pulse-Width Modulation Falling Edge—High Byte

Writing to TMR3_PWMxH stores the value in a temporary holding register. A parallel 16-bit Write of {TMR3_PWMxH[7–0], TMR3_PWMxL[7–0]} occurs when software initiates a Write to TMR3_PWMxL. The register is detailed in Table 79.

Table 79. PWMx Falling-Edge Register—High Byte
(TMR3_PWM0H = 0085h, TMR3_PWM1H = 0087h, TMR3_PWM2H = 0089h, TMR3_PWM3H = 008Bh)

| Bit | 7 | 6 | 5 | 4 | 3 | 2 | 1 | 0 |
|-------------------|-----|-----|-----|-----|-----|-----|-----|-----|
| Reset | 0 | 0 | 0 | 0 | 0 | 0 | 0 | 0 |
| CPU Access | R/W | R/W | R/W | R/W | R/W | R/W | R/W | R/W |

Note: R/W = Read/Write.

| Bit Position | Value | Description |
|----------------|---------|---|
| [7:0] PWMxH | 00h–FFh | These bits represent the High byte of the 16-bit value to set the falling edge COMPARE value for PWMx, {TMR3_PWMxH[7:0], TMR3_PWMxL[7:0]}. Bit 7 is bit 15 (msb) of the 16-bit timer data value. Bit 0 is bit 8 of the 16-bit timer data value. |

Real-Time Clock

Real-Time Clock Overview

The Real-Time Clock (RTC) keeps time by maintaining a count of seconds, minutes, hours, day-of-the-week, day-of-the-month, year, and century. The current time is kept in 24-hour format. The format for all count and alarm registers is selectable between binary and binary-coded-decimal (BCD) operations. The calendar operation maintains the correct day of the month and automatically compensates for leap year. A simplified block diagram of the RTC and the associated on-chip, low-power, 32KHz oscillator is illustrated in Figure 34. Connections to an external battery supply and 32KHz crystal network are also demonstrated in Figure 34.

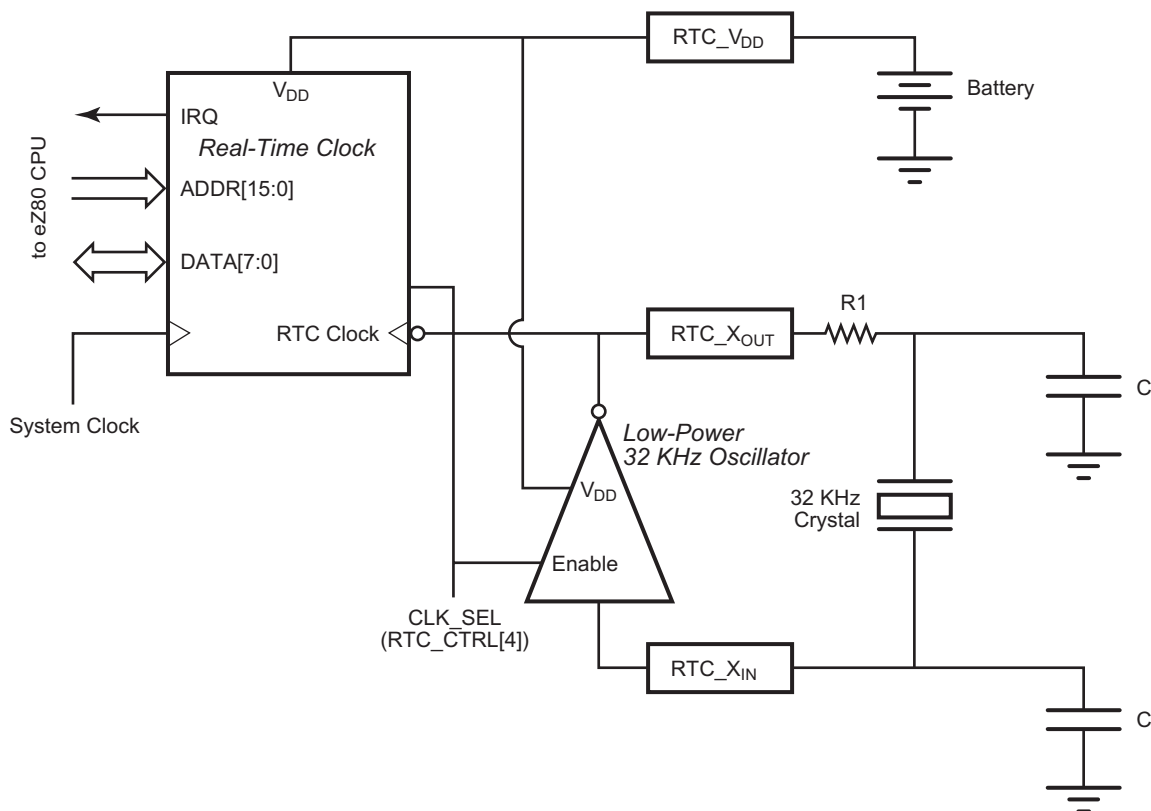

Figure 34. Real-Time Clock and 32KHz Oscillator Block Diagram

Real-Time Clock Alarm

The clock can be programmed to generate an alarm condition when the current count matches the alarm set-point registers. Alarm registers are available for seconds, minutes, hours, and day-of-the-week. Each alarm can be independently enabled. To generate an alarm condition, the current time must match all enabled alarm values. For example, if the day-of-the-week and hour alarms are both enabled, the alarm only occurs at the specified hour on the specified day. The alarm triggers an interrupt if the interrupt enable bit, INT_EN, is set to 1. The alarm flag, ALARM, and corresponding interrupt to the CPU are cleared by reading the RTC_CTRL register.

Alarm value registers and alarm control registers can be written at any time. Alarm conditions are generated when the count value matches the alarm value. The comparison of alarm and count values occurs whenever the RTC count increments (one time every second). The RTC can also be forced to perform a comparison at any time by writing a 0 to the RTC_UNLOCK bit (the RTC_UNLOCK bit is not required to be changed to a 1 first).

Real-Time Clock Oscillator and Source Selection

The RTC count is driven by either the on-chip 32768Hz crystal oscillator or a 50/60Hz power-line frequency input connected to the 32KHz RTC_XOUT pin. An internal divider compensates for each of these options. The clock source and power-line frequencies are selected in the RTC_CTRL register. Writing to the RTC_CTRL register resets the clock divider.

Real-Time Clock Battery Backup

The power supply pin (RTC_VDD) for the Real-Time Clock and associated low-power 32KHz oscillator is isolated from the other power supply pins on the eZ80F91 device. To ensure that the RTC continues to keep time in the event of loss of line power to the application, a battery can be used to supply power to the RTC and the oscillator via the RTC_VDD pin. All VSS (ground) pins should be connected together on the printed circuit assembly.

Real-Time Clock Recommended Operation

Following a initial system reset from a powered-down condition of VDD and VDD_RTC, the counter values of the RTC are undefined and all alarms are disabled. The following procedure is recommended to initialize the Real-Time Clock:

- Write to RTC_CTRL to set RTC_UNLOCK and disable the RTC counter; this action also clears the clock divider
- Write values to the RTC count registers to set the current time



- Write values to the RTC alarm registers to set the appropriate alarm conditions
- Write to RTC_CTRL to clear RTC_UNLOCK; clearing the RTC_UNLOCK bit resets and enables the clock divider

Real-Time Clock Registers

The Real-Time Clock registers are accessed via the address and data buses using I/O instructions. The RTC_UNLOCK control bit controls access to the RTC count registers. When unlocked (RTC_UNLOCK = 1), the RTC count is disabled and the count registers are Read/Write. When locked (RTC_UNLOCK = 0), the RTC count is enabled and the count registers are Read Only. The default, at RESET, is for the RTC to be locked.

Real-Time Clock Seconds Register

This register contains the current seconds count. The value in the RTC_SEC register is unchanged by a RESET. The current setting of BCD_EN determines whether the values in this register are binary (BCD_EN = 0) or binary-coded decimal (BCD_EN = 1). Access to this register is Read Only if the RTC is locked and Read/Write if the RTC is unlocked. See Table 80.

Table 80. Real-Time Clock Seconds Register (RTC_SEC = 00E0h)

| Bit | 7 | 6 | 5 | 4 | 3 | 2 | 1 | 0 |
|------------|------|------|------|------|------|------|------|------|
| Reset | X | X | X | X | X | X | X | X |
| CPU Access | R/W* | R/W* | R/W* | R/W* | R/W* | R/W* | R/W* | R/W* |

Note: X = Unchanged by RESET; R/W* = Read Only if RTC locked, Read/Write if RTC unlocked.

Binary-Coded-Decimal Operation (BCD_EN = 1)

| Bit Position | Value | Description |
|------------------|-------|--|
| [7:4] TEN_SEC | 0–5 | The tens digit of the current seconds count. |
| [3:0] SEC | 0–9 | The ones digit of the current seconds count. |

Binary Operation (BCD_EN = 0)

| Bit Position | Value | Description |
|--------------|-------------|----------------------------|
| [7:0] SEC | 00h– 3Bh | The current seconds count. |



Real-Time Clock Minutes Register

This register contains the current minutes count. The value in the RTC_MIN register is unchanged by a RESET. The current setting of BCD_EN determines whether the values in this register are binary (BCD_EN = 0) or binary-coded decimal (BCD_EN = 1). Access to this register is Read Only if the RTC is locked and Read/Write if the RTC is unlocked. See Table 81.

Table 81. Real-Time Clock Minutes Register (RTC_MIN = 00E1h)

| Bit | 7 | 6 | 5 | 4 | 3 | 2 | 1 | 0 |
|-------------------|------|------|------|------|------|------|------|------|
| Reset | X | X | X | X | X | X | X | X |
| CPU Access | R/W* | R/W* | R/W* | R/W* | R/W* | R/W* | R/W* | R/W* |

Note: X = Unchanged by RESET; R/W* = Read Only if RTC locked, Read/Write if RTC unlocked.

Binary-Coded-Decimal Operation (BCD_EN = 1)

| Bit Position | Value | Description |
|------------------|-------|--|
| [7:4] TEN_MIN | 0–5 | The tens digit of the current minutes count. |
| [3:0] MIN | 0–9 | The ones digit of the current minutes count. |

Binary Operation (BCD_EN = 0)

| Bit Position | Value | Description |
|--------------|-------------|----------------------------|
| [7:0] MIN | 00h– 3Bh | The current minutes count. |

Real-Time Clock Hours Register

This register contains the current hours count. The value in the RTC_HRS register is unchanged by a RESET. The current setting of BCD_EN determines whether the values in this register are binary (BCD_EN = 0) or binary-coded decimal (BCD_EN = 1). Access to this register is Read Only if the RTC is locked and Read/Write if the RTC is unlocked. See Table 82.

**Table 82. Real-Time Clock Hours Register
(RTC_HRS = 00E2h)**

| Bit | 7 | 6 | 5 | 4 | 3 | 2 | 1 | 0 |
|-------------------|------|------|------|------|------|------|------|------|
| Reset | X | X | X | X | X | X | X | X |
| CPU Access | R/W* | R/W* | R/W* | R/W* | R/W* | R/W* | R/W* | R/W* |

Note: X = Unchanged by RESET; R/W* = Read Only if RTC locked, Read/Write if RTC unlocked.

Binary-Coded-Decimal Operation (BCD_EN = 1)

| Bit Position | Value | Description |
|------------------|-------|--|
| [7:4] TEN_HRS | 0–2 | The tens digit of the current hours count. |
| [3:0] HRS | 0–9 | The ones digit of the current hours count. |

Binary Operation (BCD_EN = 0)

| Bit Position | Value | Description |
|--------------|-------------|--------------------------|
| [7:0] HRS | 00h– 17h | The current hours count. |



Real-Time Clock Day-of-the-Week Register

This register contains the current day-of-the-week count. The RTC_DOW register begins counting at 01h. The value in the RTC_DOW register is unchanged by a RESET. The current setting of BCD_EN determines whether the value in this register is binary (BCD_EN = 0) or binary-coded decimal (BCD_EN = 1). Access to this register is Read Only if the RTC is locked and Read/Write if the RTC is unlocked. See Table 83.

**Table 83. Real-Time Clock Day-of-the-Week Register
(RTC_DOW = 00E3h)**

| Bit | 7 | 6 | 5 | 4 | 3 | 2 | 1 | 0 |
|-------------------|---|---|---|---|------|------|------|------|
| Reset | 0 | 0 | 0 | 0 | X | X | X | X |
| CPU Access | R | R | R | R | R/W* | R/W* | R/W* | R/W* |

Note: X = Unchanged by RESET; R = Read Only; R/W* = Read Only if RTC locked, Read/Write if RTC unlocked.

Binary-Coded-Decimal Operation (BCD_EN = 1)

| Bit Position | Value | Description |
|--------------|-------|------------------------------------|
| [7:4] | 0000 | Reserved. |
| [3:0] DOW | 1–7 | The current day-of-the-week count. |

Binary Operation (BCD_EN = 0)

| Bit Position | Value | Description |
|--------------|-------------|------------------------------------|
| [7:4] | 0000 | Reserved. |
| [3:0] DOW | 01h– 07h | The current day-of-the-week count. |



Real-Time Clock Day-of-the-Month Register

This register contains the current day-of-the-month count. The RTC_DOM register begins counting at 01h. The value in the RTC_DOM register is unchanged by a RESET. The current setting of BCD_EN determines whether the values in this register are binary (BCD_EN = 0) or binary-coded decimal (BCD_EN = 1). Access to this register is Read Only if the RTC is locked and Read/Write if the RTC is unlocked. See Table 84.

Table 84. Real-Time Clock Day-of-the-Month Register (RTC_DOM = 00E4h)

| Bit | 7 | 6 | 5 | 4 | 3 | 2 | 1 | 0 |
|-------------------|------|------|------|------|------|------|------|------|
| Reset | X | X | X | X | X | X | X | X |
| CPU Access | R/W* | R/W* | R/W* | R/W* | R/W* | R/W* | R/W* | R/W* |

Note: X = Unchanged by RESET; R/W* = Read Only if RTC locked, Read/Write if RTC unlocked.

Binary-Coded-Decimal Operation (BCD_EN = 1)

| Bit Position | Value | Description |
|-------------------|-------|---|
| [7:4] TENS_DOM | 0–3 | The tens digit of the current day-of-the-month count. |
| [3:0] DOM | 0–9 | The ones digit of the current day-of-the-month count. |

Binary Operation (BCD_EN = 0)

| Bit Position | Value | Description |
|--------------|-------------|-------------------------------------|
| [7:0] DOM | 01h– 1Fh | The current day-of-the-month count. |



Real-Time Clock Month Register

This register contains the current month count. The RTC_MON register begins counting at 01h. The value in the RTC_MON register is unchanged by a RESET. The current setting of BCD_EN determines whether the values in this register are binary (BCD_EN = 0) or binary-coded decimal (BCD_EN = 1). Access to this register is Read Only if the RTC is locked and Read/Write if the RTC is unlocked. See Table 85.

Table 85. Real-Time Clock Month Register (RTC_MON = 00E5h)

| Bit | 7 | 6 | 5 | 4 | 3 | 2 | 1 | 0 |
|------------|------|------|------|------|------|------|------|------|
| Reset | X | X | X | X | X | X | X | X |
| CPU Access | R/W* | R/W* | R/W* | R/W* | R/W* | R/W* | R/W* | R/W* |

Note: X = Unchanged by RESET; R/W* = Read Only if RTC locked, Read/Write if RTC unlocked.

Binary-Coded-Decimal Operation (BCD_EN = 1)

| Bit Position | Value | Description |
|-------------------|-------|--|
| [7:4] TENS_MON | 0–1 | The tens digit of the current month count. |
| [3:0] MON | 0–9 | The ones digit of the current month count. |

Binary Operation (BCD_EN = 0)

| Bit Position | Value | Description |
|--------------|-------------|--------------------------|
| [7:0] MON | 01h– 0Ch | The current month count. |



Real-Time Clock Year Register

This register contains the current year count. The value in the RTC_YR register is unchanged by a RESET. The current setting of BCD_EN determines whether the values in this register are binary (BCD_EN = 0) or binary-coded decimal (BCD_EN = 1). Access to this register is Read Only if the RTC is locked and Read/Write if the RTC is unlocked. See Table 86.

Table 86. Real-Time Clock Year Register (RTC_YR = 00E6h)

| Bit | 7 | 6 | 5 | 4 | 3 | 2 | 1 | 0 |
|-------------------|------|------|------|------|------|------|------|------|
| Reset | X | X | X | X | X | X | X | X |
| CPU Access | R/W* | R/W* | R/W* | R/W* | R/W* | R/W* | R/W* | R/W* |

Note: X = Unchanged by RESET; R/W* = Read Only if RTC locked, Read/Write if RTC unlocked.

Binary-Coded-Decimal Operation (BCD_EN = 1)

| Bit Position | Value | Description |
|------------------|-------|---|
| [7:4] TENS_YR | 0–9 | The tens digit of the current year count. |
| [3:0] YR | 0–9 | The ones digit of the current year count. |

Binary Operation (BCD_EN = 0)

| Bit Position | Value | Description |
|--------------|-------------|-------------------------|
| [7:0] YR | 00h– 63h | The current year count. |



Real-Time Clock Century Register

This register contains the current century count. The value in the RTC_CEN register is unchanged by a RESET. The current setting of BCD_EN determines whether the values in this register are binary (BCD_EN = 0) or binary-coded decimal (BCD_EN = 1). Access to this register is Read Only if the RTC is locked and Read/Write if the RTC is unlocked. See Table 87.

Table 87. Real-Time Clock Century Register (RTC_CEN = 00E7h)

| Bit | 7 | 6 | 5 | 4 | 3 | 2 | 1 | 0 |
|-------------------|------|------|------|------|------|------|------|------|
| Reset | X | X | X | X | X | X | X | X |
| CPU Access | R/W* | R/W* | R/W* | R/W* | R/W* | R/W* | R/W* | R/W* |

Note: X = Unchanged by RESET; R/W* = Read Only if RTC locked, Read/Write if RTC unlocked.

Binary-Coded-Decimal Operation (BCD_EN = 1)

| Bit Position | Value | Description |
|-------------------|-------|--|
| [7:4] TENS_CEN | 0–9 | The tens digit of the current century count. |
| [3:0] CEN | 0–9 | The ones digit of the current century count. |

Binary Operation (BCD_EN = 0)

| Bit Position | Value | Description |
|--------------|-------------|----------------------------|
| [7:0] CEN | 00h– 63h | The current century count. |



Real-Time Clock Alarm Seconds Register

This register contains the alarm seconds value. The value in the RTC_ASEC register is unchanged by a RESET. The current setting of BCD_EN determines whether the values in this register are binary (BCD_EN = 0) or binary-coded decimal (BCD_EN = 1). See Table 88.

Table 88. Real-Time Clock Alarm Seconds Register (RTC_ASEC = 00E8h)

| Bit | 7 | 6 | 5 | 4 | 3 | 2 | 1 | 0 |
|-------------------|-----|-----|-----|-----|-----|-----|-----|-----|
| Reset | X | X | X | X | X | X | X | X |
| CPU Access | R/W | R/W | R/W | R/W | R/W | R/W | R/W | R/W |

Note: X = Unchanged by RESET; R/W = Read/Write.

Binary-Coded-Decimal Operation (BCD_EN = 1)

| Bit Position | Value | Description |
|-------------------|-------|--|
| [7:4] ATEN_SEC | 0–5 | The tens digit of the alarm seconds value. |
| [3:0] ASEC | 0–9 | The ones digit of the alarm seconds value. |

Binary Operation (BCD_EN = 0)

| Bit Position | Value | Description |
|---------------|-------------|--------------------------|
| [7:0] ASEC | 00h– 3Bh | The alarm seconds value. |



Real-Time Clock Alarm Minutes Register

This register contains the alarm minutes value. The value in the RTC_AMIN register is unchanged by a RESET. The current setting of BCD_EN determines whether the values in this register are binary (BCD_EN = 0) or binary-coded decimal (BCD_EN = 1). See Table 89.

Table 89. Real-Time Clock Alarm Minutes Register (RTC_AMIN = 00E9h)

| Bit | 7 | 6 | 5 | 4 | 3 | 2 | 1 | 0 |
|------------|-----|-----|-----|-----|-----|-----|-----|-----|
| Reset | X | X | X | X | X | X | X | X |
| CPU Access | R/W | R/W | R/W | R/W | R/W | R/W | R/W | R/W |

Note: X = Unchanged by RESET; R/W = Read/Write.

Binary-Coded-Decimal Operation (BCD_EN = 1)

| Bit Position | Value | Description |
|-------------------|-------|--|
| [7:4] ATEN_MIN | 0–5 | The tens digit of the alarm minutes value. |
| [3:0] AMIN | 0–9 | The ones digit of the alarm minutes value. |

Binary Operation (BCD_EN = 0)

| Bit Position | Value | Description |
|---------------|-------------|--------------------------|
| [7:0] AMIN | 00h– 3Bh | The alarm minutes value. |



Real-Time Clock Alarm Hours Register

This register contains the alarm hours value. The value in the RTC_AHRS register is unchanged by a RESET. The current setting of BCD_EN determines whether the values in this register are binary (BCD_EN = 0) or binary-coded decimal (BCD_EN = 1). See Table 90.

Table 90. Real-Time Clock Alarm Hours Register (RTC_AHRS = 00EAh)

| Bit | 7 | 6 | 5 | 4 | 3 | 2 | 1 | 0 |
|-------------------|-----|-----|-----|-----|-----|-----|-----|-----|
| Reset | X | X | X | X | X | X | X | X |
| CPU Access | R/W | R/W | R/W | R/W | R/W | R/W | R/W | R/W |

Note: X = Unchanged by RESET; R/W = Read/Write.

Binary-Coded-Decimal Operation (BCD_EN = 1)

| Bit Position | Value | Description |
|-------------------|-------|--|
| [7:4] ATEN_HRS | 0–2 | The tens digit of the alarm hours value. |
| [3:0] AHRS | 0–9 | The ones digit of the alarm hours value. |

Binary Operation (BCD_EN = 0)

| Bit Position | Value | Description |
|---------------|-------------|------------------------|
| [7:0] AHRS | 00h– 17h | The alarm hours value. |



Real-Time Clock Alarm Day-of-the-Week Register

This register contains the alarm day-of-the-week value. The value in the RTC_ADOW register is unchanged by a RESET. The current setting of BCD_EN determines whether the value in this register is binary (BCD_EN = 0) or binary-coded decimal (BCD_EN = 1). See Table 91.

Table 91. Real-Time Clock Alarm Day-of-the-Week Register (RTC_ADOW = 00EBh)

| Bit | 7 | 6 | 5 | 4 | 3 | 2 | 1 | 0 |
|-------------------|---|---|---|---|------|------|------|------|
| Reset | 0 | 0 | 0 | 0 | X | X | X | X |
| CPU Access | R | R | R | R | R/W* | R/W* | R/W* | R/W* |

Note: X = Unchanged by RESET; R = Read Only; R/W* = Read Only if RTC locked, Read/Write if RTC unlocked.

Binary-Coded-Decimal Operation (BCD_EN = 1)

| Bit Position | Value | Description |
|---------------|-------|----------------------------------|
| [7:4] | 0000 | Reserved. |
| [3:0] ADOW | 1–7 | The alarm day-of-the-week.value. |

Binary Operation (BCD_EN = 0)

| Bit Position | Value | Description |
|---------------|-------------|----------------------------------|
| [7:4] | 0000 | Reserved. |
| [3:0] ADOW | 01h– 07h | The alarm day-of-the-week value. |



Real-Time Clock Alarm Control Register

This register contains control bits for the Real-Time Clock. The RTC_ACTRL register is cleared by a RESET. See Table 92.

Table 92. Real-Time Clock Alarm Control Register (RTC_ACTRL = 00ECh)

| Bit | 7 | 6 | 5 | 4 | 3 | 2 | 1 | 0 |
|-------------------|---|---|---|---|-----|-----|-----|-----|
| Reset | 0 | 0 | 0 | 0 | 0 | 0 | 0 | 0 |
| CPU Access | R | R | R | R | R/W | R/W | R/W | R/W |

Note: X = Unchanged by RESET; R = Read Only; R/W = Read/Write

| Bit Position | Value | Description |
|--------------|--------|---|
| [7:4] | 0000 | Reserved. |
| 3 ADOW_EN | 0 1 | The day-of-the-week alarm is disabled. The day-of-the-week alarm is enabled. |
| 2 AHRS_EN | 0 1 | The hours alarm is disabled. The hours alarm is enabled. |
| 1 AMIN_EN | 0 1 | The minutes alarm is disabled. The minutes alarm is enabled. |
| 0 ASEC_EN | 0 1 | The seconds alarm is disabled. The seconds alarm is enabled. |



Real-Time Clock Control Register

This register contains control and status bits for the Real-Time Clock. Some bits in the RTC_CTRL register are cleared by a RESET. The ALARM bit flag and associated interrupt (if INT_EN is enabled) are cleared by reading this register. The ALARM bit flag is updated by clearing (locking) the RTC_UNLOCK bit or by an increment of the RTC count. Writing to the RTC_CTRL register also resets the RTC count prescaler allowing the RTC to be synchronized to another time source.

SLP_WAKE indicates if an RTC alarm condition initiated the CPU recovery from SLEEP mode. This bit can be checked after RESET to determine if a sleep-mode recovery is caused by the RTC. SLP_WAKE is cleared by a Read of the RTC_CTRL register.

Setting the BCD_EN bit causes the RTC to use BCD counting in all registers including the alarm set points.

The CLK_SEL and FREQ_SEL bits select the RTC clock source. If the 32KHz crystal option is selected the oscillator is enabled and the internal prescaler is set to divide by 32768. If the power-line frequency option is selected, the prescale value is set by the FREQ_SEL bit, and the 32KHz oscillator is disabled. See Table 93.

Table 93. Real-Time Clock Control Register (RTC_CTRL = 00EDh)

| Bit | 7 | 6 | 5 | 4 | 3 | 2 | 1 | 0 |
|-------------------|---|-----|-----|-----|-----|-----|-----|-----|
| Reset | X | 0 | X | X | X | X | 0/1 | 0 |
| CPU Access | R | R/W | R/W | R/W | R/W | R/W | R | R/W |

Note: X = Unchanged by RESET; R = Read Only; R/W = Read/Write.

| Bit Position | Value | Description |
|--------------|-------|---|
| 7 ALARM | 0 | Alarm interrupt is inactive. |
| | 1 | Alarm interrupt is active. |
| 6 INT_EN | 0 | Interrupt on alarm condition is disabled. |
| | 1 | Interrupt on alarm condition is enabled. |
| 5 BCD_EN | 0 | RTC count and alarm value registers are binary. |
| | 1 | RTC count and alarm value registers are binary-coded decimal (BCD). |



| Bit Position | Value | Description |
|-----------------|-------|--|
| 4 CLK_SEL | 0 | RTC clock source is crystal oscillator output (32768Hz). On-chip 32768Hz oscillator is enabled. |
| | 1 | RTC clock source is power-line frequency input. On-chip 32768Hz oscillator is disabled. |
| 3 FREQ_SEL | 0 | Power-line frequency is 60Hz. |
| | 1 | Power-line frequency is 50Hz. |
| 2 DAY_SAV | 0 | Daylight Savings Time not selected. |
| | 1 | Daylight Savings Time selected. |
| 1 SLP_WAKE | 0 | RTC did not generate a sleep-mode recovery reset. |
| | 1 | RTC Alarm generated a sleep-mode recovery reset. |
| 0 RTC_UNLOCK | 0 | RTC count registers are locked to prevent write access. RTC counter is enabled. |
| | 1 | RTC count registers are unlocked to allow write access. RTC counter is disabled. |

www.DataSheet4U.com

Universal Asynchronous Receiver/Transmitter

The UART module implements all of the logic required to support the asynchronous communications protocol. The module also implements two separate 16-byte-deep FIFOs for both transmission and reception. A block diagram of the UART is illustrated in Figure 35.

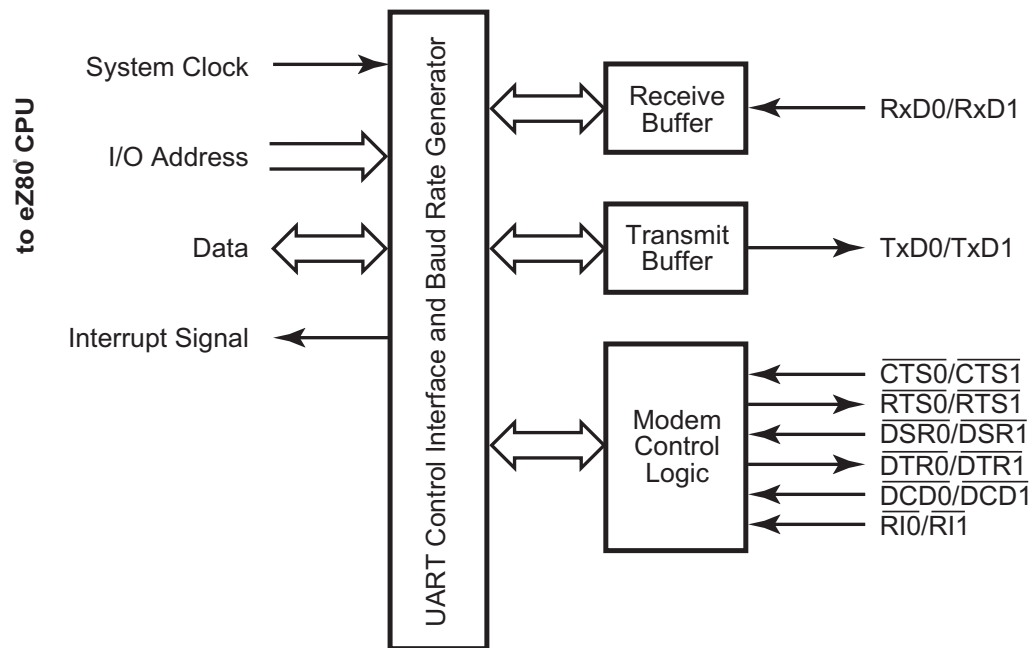

Figure 35. UART Block Diagram

The UART module provides the following asynchronous communications protocol-related features and functions:

- 5-, 6-, 7-, 8- or 9-bit data transmission
- Even/odd, space/mark, address/data, or no parity bit generation and detection
- Start and stop bit generation and detection (supports up to two stop bits)
- Line break detection and generation
- Receiver overrun and framing errors detection
- Logic and associated I/O to provide modem handshake capability

UART Functional Description

The UART Baud Rate Generator creates the clock for the serial transmit and receive functions. The UART module supports all of the various options in the asynchronous transmission and reception protocol including:

- 5- to 9-bit transmit/receive
- Start bit generation and detection
- Parity generation and detection
- Stop bit generation and detection
- Break generation and detection

The UART contains 16-byte-deep FIFOs in each direction. The FIFOs can be enabled or disabled by the application. The receive FIFO features trigger-level detection logic, which enables the CPU to block-transfer data bytes from the receive FIFO.

UART Functions

The UART function implements:

- The transmitter and associated control logic
- The receiver and associated control logic
- The modem interface and associated logic

UART Transmitter

The transmitter block controls the data transmitted on the TxD output. It implements the FIFO, access via the UARTx_THR register, the transmit shift register, the parity generator, and control logic for the transmitter to control parameters for the asynchronous communications protocol.

The UARTx_THR is a Write Only register. The CPU writes the data byte to be transmitted into this register. In FIFO mode, up to 16 data bytes can be written via the UARTx_THR register. The data byte from the FIFO is transferred to the transmit shift register at the appropriate time and transmitted via TxD output. After SYNC_RESET, the UARTx_THR register is empty. Therefore, the Transmit Holding Register Empty (THRE) bit (bit 5 of the **UARTx_LSR** register) is 1. An interrupt is sent to the CPU if interrupts are enabled. The CPU can reset this interrupt by loading data into the UARTx_THR register, which clears the transmitter interrupt.

The transmit shift register places the byte to be transmitted on the TxD signal serially. The least-significant bit of the byte to be transmitted is shifted out first and the most-significant bit is shifted out last. The control logic within the block adds the asynchronous communications protocol bits to the data byte being transmitted.

The transmitter block obtains the parameters for the protocol from the bits programmed via the UARTx_LCTL register. When enabled, an interrupt is generated after the final protocol bit is transmitted, which the CPU can reset by loading data into the UARTx_THR register. The TxD output is set to 1 if the transmitter is idle (i.e., the transmitter does not contain any data to be transmitted).

The transmitter operates with the Baud Rate Generator (BRG) clock. The data bits are placed on the TxD output one time every 16 BRG clock cycles. The transmitter block also implements a parity generator that attaches the parity bit to the byte, if programmed. For 9-bit data, the host CPU programs the parity bit generator so that it marks the byte as either address (mark parity) or data (space parity).

UART Receiver

The receiver block controls the data reception from the RxD signal. The receiver block implements a receiver shift register, receiver line error condition monitoring logic and receiver data ready logic. It also implements the parity checker.

The UARTx_RBR is a Read Only register of the module. The CPU reads received data from this register. The condition of the UARTx_RBR register is monitored by the DR bit (bit 0 of the UARTx_LSR register). The DR bit is 1 when a data byte is received and transferred to the UARTx_RBR register from the receiver shift register. The DR bit is reset only when the CPU reads all of the received data bytes. If the number of bits received is less than eight, the unused most-significant bits of the data byte Read are 0.

For 9-bit data, the receiver checks incoming bytes for space parity. A line status interrupt is generated when an address byte is received, because address bytes maintain high parity bits. The CPU clears the interrupt by determining if the address matches its own, then configures the receiver to either accept the subsequent data bytes if the address matches, or ignore the data if the address does not match.

The receiver uses the clock from the BRG for receiving the data. This clock must operate at 16 times the appropriate baud rate. The receiver synchronizes the shift clock on the falling edge of the RxD input start bit. It then receives a complete byte according to the set parameters. The receiver also implements logic to detect framing errors, parity errors, overrun errors, and break signals.

UART Modem Control

The modem control logic provides two outputs and four inputs for handshaking with the modem. Any change in the modem status inputs, except RI, is detected and an interrupt can be generated. For RI, an interrupt is generated only when the trailing edge of the RI is detected. The module also provides LOOP mode for self-diagnostics.

UART Interrupts

There are six different sources of interrupts from the UART. The six sources of interrupts are:

- Transmitter (two different interrupts)
- Receiver (three different interrupts)
- Modem status

UART Transmitter Interrupt

A Transmitter Hold Register Empty interrupt is generated if there is no data available in the hold register. By the same token, a transmission complete interrupt is generated after the data in the shift register is sent. Both interrupts can be disabled using individual interrupt enable bits, or cleared by writing data into the UARTx_THR register.

UART Receiver Interrupts

A receiver interrupt can be generated by three possible events. The first event, a receiver data ready interrupt event, indicates that one or more data bytes are received and are ready to be read. Next, this interrupt is generated if the number of bytes in the receiver FIFO is greater than or equal to the trigger level. If the FIFO is not enabled, the interrupt is generated if the receive buffer contains a data byte. This interrupt is cleared by reading the UARTx_RBR.

The second interrupt source is the receiver time-out. A receiver time-out interrupt is generated when there are fewer data bytes in the receiver FIFO than the trigger level and there are no Reads and Writes to or from the receiver FIFO for four consecutive byte times. When the receiver time-out interrupt is generated, it is cleared only after emptying the entire receive FIFO.

The first two interrupt sources from the receiver (data ready and time-out) share an interrupt enable bit. The third source of a receiver interrupt is a line status error, indicating an error in byte reception. This error can result from:

- Incorrect received parity

► **Note:** For 9-bit data, *incorrect parity* indicates detection of an address byte.

- Incorrect framing (i.e., the stop bit) is not detected by receiver at the end of the byte
- Receiver overrun condition
- A BREAK condition being detected on the receive data input

An interrupt due to one of the above conditions is cleared when the UARTx_LSR register is read. In case of FIFO mode, a line status interrupt is generated only after the received byte with an error reaches the top of the FIFO and is ready to be read.

A line status interrupt is activated (provided this interrupt is enabled) as long as the Read pointer of the receiver FIFO points to the location of the FIFO that contains a byte with the error. The interrupt is immediately cleared when the UARTx_LSR register is read. The ERR bit of the UARTx_LSR register is active as long as an erroneous byte is present in the receiver FIFO.

UART Modem Status Interrupt

The modem status interrupt is generated if there is any change in state of the modem status inputs to the UART. This interrupt is cleared when the CPU reads the UARTx_MSR register.

UART Recommended Usage

The following standard sequence of events occurs in the UART block of the eZ80F91 device. A description of each follows.

1. Module reset.
2. Control transfers to configure UART operation.
3. Data transfers.

Module Reset

Upon reset, all internal registers are set to their default values. All command status registers are programmed with their default values, and the FIFOs are flushed.

Control Transfers

Based on the requirements of the application, the data transfer baud rate is determined and the BRG is configured to generate a 16X clock frequency. Interrupts are disabled and the communication control parameters are programmed in the UARTx_LCTL register. The FIFO configuration is determined and the receive trigger levels are set in the UARTx_FCTL register. The status registers, UARTx_LSR and UARTx_MSR, are read to ensure that none of the interrupt sources are active. The interrupts are enabled (except for the transmit interrupt) and the application is ready to use the module for transmission/reception.

Data Transfers

Transmit. To transmit data, the application enables the transmit interrupt. An interrupt is immediately expected in response. The application reads the UARTx_IIR

register and determines whether the interrupt occurs due to either an empty UARTx_THR register or a completed transmission. When the application makes this determination, it writes the transmit data bytes to the UARTx_THR register. The number of bytes that the application writes depends on whether or not the FIFO is enabled. If the FIFO is enabled, the application can write 16 bytes at a time. If not, the application can write one byte at a time. As a result of the first Write, the interrupt is deactivated. The CPU then waits for the next interrupt. When the interrupt is raised by the UART module, the CPU repeats the same process until it exhausts all of the data for transmission.

To control and check the modem status, the application sets up the modem by writing to the UARTx_MCTL register and reading the UARTx_MCTL register before starting the process described above.

Receive. The receiver is always enabled, and it continually checks for the start bit on the RxD input signal. When an interrupt is raised by the UART module, the application reads the UARTx_IIR register and determines the cause for the interrupt. If the cause is a line status interrupt, the application reads the UARTx_LSR register, reads the data byte and then can discard the byte or take other appropriate action. If the interrupt is caused by a receive-data-ready condition, the application alternately reads the UARTx_LSR and UARTx_RBR registers and removes all of the received data bytes. It reads the UARTx_LSR register before reading the UARTx_RBR register to determine that there is no error in the received data.

To control and check modem status, the application sets up the modem by writing to the UARTx_MCTL register and reading the UARTx_MSR register before starting the process described above.

Poll Mode Transfers. When interrupts are disabled, all data transfers are referred to as poll mode transfers. In poll mode transfers, the application must continually poll the UARTx_LSR register to transmit or receive data without enabling the interrupts. The same holds true for the UARTx_MSR register. If the interrupts are not enabled, the data in the UARTx_IIR register cannot be used to determine the cause of interrupt.

Baud Rate Generator

The Baud Rate Generator consists of a 16-bit downcounter, two registers, and associated decoding logic. The initial value of the Baud Rate Generator is defined by the two BRG Divisor Latch registers, {UARTx_BRG_H, UARTx_BRG_L}. At the rising edge of each system clock, the BRG decrements until it reaches the value 0001h. On the next system clock rising edge, the BRG reloads the initial value from {UARTx_BRG_H, UARTx_BRG_L} and outputs a pulse to indicate the end-of-count.

Calculate the UART data rate with the following equation:

$$\text{UART Data Rate (bits/s)} = \frac{\text{System Clock Frequency}}{16 \times \text{UART Baud Rate Generator Divisor}}$$

Upon RESET, the 16-bit BRG divisor value resets to the smallest allowable value of 0002h. Therefore, the minimum BRG clock divisor ratio is 2. A software Write to either the Low- or High-byte registers for the BRG Divisor Latch causes both the Low and High bytes to load into the BRG counter, and causes the count to restart.

The divisor registers can only be accessed if bit 7 of the UART Line Control register (UARTx_LCTL) is set to 1. After reset, this bit is reset to 0.

Recommended Use of the Baud Rate Generator

The following is the normal sequence of operations that should occur after the eZ80F91 is powered on to configure the Baud Rate Generator:

1. Assert and deassert RESET.
2. Set UARTx_LCTL[7] to 1 to enable access of the BRG divisor registers.
3. Program the UARTx_BRG_L and UARTx_BRG_H registers.
4. Clear UARTx_LCTL[7] to 0 to disable access of the BRG divisor registers.

BRG Control Registers

UART Baud Rate Generator Register—Low and High Bytes

The registers hold the Low and High bytes of the 16-bit divisor count loaded by the CPU for UART baud rate generation. The 16-bit clock divisor value is returned by {UARTx_BRG_H, UARTx_BRG_L}, where *x* is either 0 or 1 to identify the two available UART devices. Upon RESET, the 16-bit BRG divisor value resets to 0002h. The initial 16-bit divisor value must be between 0002h and FFFFh, because the values 0000h and 0001h are invalid and proper operation is not guaranteed at these two values. As a result, the minimum BRG clock divisor ratio is 2.

A Write to either the Low- or High-byte registers for the BRG Divisor Latch causes both bytes to be loaded into the BRG counter. The count is then restarted.

Bit 7 of the associated UART Line Control register (UARTx_LCTL) must be set to 1 to access this register. See Tables 94 and 95. Refer to the [UART Line Control Register](#) (UARTx_LCTL) on page 196 for more information.



- **Note:** The UARTx_BRG_L registers share the same address space with the UARTx_RBR and UARTx_THR registers. The UARTx_BRG_H registers share the same address space with the UARTx_IER registers. Bit 7 of the associated UART Line Control register (UARTx_LCTL) must be set to 1 to enable access to the BRG registers.

Table 94. UART Baud Rate Generator Register—Low Bytes
(UART0_BRG_L = 00C0h, UART1_BRG_L = 00D0h)

| Bit | 7 | 6 | 5 | 4 | 3 | 2 | 1 | 0 |
|-------------------|-----|-----|-----|-----|-----|-----|-----|-----|
| Reset | 0 | 0 | 0 | 0 | 0 | 0 | 1 | 0 |
| CPU Access | R/W | R/W | R/W | R/W | R/W | R/W | R/W | R/W |

Note: R = Read only; R/W = Read/Write.

| Bit Position | Value | Description |
|---------------------|-------------|--|
| [7:0] UART_BRG_L | 00h– FFh | These bits represent the Low byte of the 16-bit Baud Rate Generator divider value. The complete BRG divisor value is returned by {UART_BRG_H, UART_BRG_L}. |

Table 95. UART Baud Rate Generator Register—High Bytes
(UART0_BRG_H = 00C1h, UART1_BRG_H = 00D1h)

| Bit | 7 | 6 | 5 | 4 | 3 | 2 | 1 | 0 |
|-------------------|-----|-----|-----|-----|-----|-----|-----|-----|
| Reset | 0 | 0 | 0 | 0 | 0 | 0 | 0 | 0 |
| CPU Access | R/W | R/W | R/W | R/W | R/W | R/W | R/W | R/W |

Note: R = Read only; R/W = Read/Write.

| Bit Position | Value | Description |
|---------------------|-------------|---|
| [7:0] UART_BRG_H | 00h– FFh | These bits represent the High byte of the 16-bit Baud Rate Generator divider value. The complete BRG divisor value is returned by {UART_BRG_H, UART_BRG_L}. |



UART Registers

After a system reset, all UART registers are set to their default values. Any Writes to unused registers or register bits are ignored and reads return a value of 0. For compatibility with future revisions, unused bits within a register should always be written with a value of 0. Read/Write attributes, reset conditions, and bit descriptions of all of the UART registers are provided in this section.

www.DataSheet4U.com

UART Transmit Holding Register

If less than eight bits are programmed for transmission, the lower bits of the byte written to this register are selected for transmission. The Transmit FIFO is mapped at this address. The user can write up to 16 bytes for transmission at one time to this address if the FIFO is enabled by the application. If the FIFO is disabled, this buffer is only one byte deep.

These registers share the same address space as the UARTx_RBR and UARTx_BRG_L registers. See Table 96.

Table 96. UART Transmit Holding Registers
(UART0_THR = 00C0h, UART1_THR = 00D0h)

| Bit | 7 | 6 | 5 | 4 | 3 | 2 | 1 | 0 |
|-------------------|---|---|---|---|---|---|---|---|
| Reset | X | X | X | X | X | X | X | X |
| CPU Access | W | W | W | W | W | W | W | W |

Note: W = Write Only.

| Bit Position | Value | Description |
|--------------|-------------|---------------------|
| [7:0] TxD | 00h– FFh | Transmit data byte. |



UART Receive Buffer Register

The bits in this register reflect the data received. If less than eight bits are programmed for reception, the lower bits of the byte reflect the bits received, whereas upper unused bits are 0. The Receive FIFO is mapped at this address. If the FIFO is disabled, this buffer is only one byte deep.

These registers share the same address space as the UARTx_THR and UARTx_BRG_L registers. See Table 97.

Table 97. UART Receive Buffer Registers
(UART0_RBR = 00C0h, UART1_RBR = 00D0h)

| Bit | 7 | 6 | 5 | 4 | 3 | 2 | 1 | 0 |
|-------------------|---|---|---|---|---|---|---|---|
| Reset | X | X | X | X | X | X | X | X |
| CPU Access | R | R | R | R | R | R | R | R |

Note: R = Read only.

| Bit Position | Value | Description |
|--------------|-------------|--------------------|
| [7:0] RxD | 00h– FFh | Receive data byte. |

UART Interrupt Enable Register

The UARTx_IER register is used to enable and disable the UART interrupts. The UARTx_IER registers share the same I/O addresses as the UARTx_BRG_H registers. See Table 98.

Table 98. UART Interrupt Enable Registers
(UART0_IER = 00C1h, UART1_IER = 00D1h)

| Bit | 7 | 6 | 5 | 4 | 3 | 2 | 1 | 0 |
|-------------------|-----|-----|-----|-----|-----|-----|-----|-----|
| Reset | 0 | 0 | 0 | 0 | 0 | 0 | 0 | 0 |
| CPU Access | R/W | R/W | R/W | R/W | R/W | R/W | R/W | R/W |

Note: R/W = Read/Write.

| Bit Position | Value | Description |
|--------------|-------|---|
| [7:5] | 000 | Reserved |
| 4 TCIE | 0 | Transmission complete interrupt is disabled |
| | 1 | Transmission complete interrupt is generated when both the transmit hold register and the transmit shift register are empty |



| Bit Position | Value | Description |
|--------------|-------|---|
| 3 MIIE | 0 | Modem interrupt on edge detect of status inputs is disabled. |
| | 1 | Modem interrupt on edge detect of status inputs is enabled. |
| 2 LSIE | 0 | Line status interrupt is disabled. |
| | 1 | Line status interrupt is enabled for receive data errors: incorrect parity bit received, framing error, overrun error, or break detection. |
| 1 TIE | 0 | Transmit interrupt is disabled. |
| | 1 | Transmit interrupt is enabled. Interrupt is generated when the transmit FIFO/buffer is empty indicating no more bytes available for transmission. |
| 0 RIE | 0 | Receive interrupt is disabled. |
| | 1 | Receive interrupt and receiver time-out interrupt are enabled. Interrupt is generated if the FIFO/buffer contains data ready to be read or if the receiver times out. |

UART Interrupt Identification Register

The Read Only UARTx_IIR register allows the user to check whether the FIFO is enabled and the status of interrupts. These registers share the same I/O addresses as the UARTx_FCTL registers. See Tables 99 and 100.

Table 99. UART Interrupt Identification Registers
(UART0_IIR = 00C2h, UART1_IIR = 00D2h)

| Bit | 7 | 6 | 5 | 4 | 3 | 2 | 1 | 0 |
|-------------------|---|---|---|---|---|---|---|---|
| Reset | 0 | 0 | 0 | 0 | 0 | 0 | 0 | 1 |
| CPU Access | R | R | R | R | R | R | R | R |

Note: R = Read only.

| Bit Position | Value | Description |
|---------------|-------|---|
| [7:6] FSTS | 00 | FIFO is disabled. |
| | 10 | Receive FIFO is disabled (Multidrop Mode) |
| | 11 | FIFO is enabled. |
| [5:4] | 00 | Reserved |



| Bit Position | Value | Description |
|----------------|-------------|--|
| [3:1] INSTS | 000– 110 | Interrupt Status Code The code indicated in these three bits is valid only if INTBIT is 1. If two internal interrupt sources are active and their respective enable bits are High, only the higher priority interrupt is seen by the application. The lower-priority interrupt code is indicated only after the higher-priority interrupt is serviced. Table 100 lists the interrupt status codes. |
| 0 INTBIT | 0 1 | There is an active interrupt source within the UART. There is not an active interrupt source within the UART. |

Table 100. UART Interrupt Status Codes

| INSTS Value | Priority | Interrupt Type |
|-------------|----------|-------------------------------------|
| 011 | Highest | Receiver Line Status |
| 010 | Second | Receive Data Ready or Trigger Level |
| 110 | Third | Character Time-out |
| 101 | Fourth | Transmission Complete |
| 001 | Fifth | Transmit Buffer Empty |
| 000 | Lowest | Modem Status |



UART FIFO Control Register

This register is used to monitor trigger levels, clear FIFO pointers, and enable or disable the FIFO. The UARTx_FCTL registers share the same I/O addresses as the UARTx_IIR registers. See Table 101.

Table 101. UART FIFO Control Registers
(UART0_FCTL = 00C2h, UART1_FCTL = 00D2h)

| Bit | 7 | 6 | 5 | 4 | 3 | 2 | 1 | 0 |
|-------------------|---|---|---|---|---|---|---|---|
| Reset | 0 | 0 | 0 | 0 | 0 | 0 | 0 | 0 |
| CPU Access | W | W | W | W | W | W | W | W |

Note: W = Write Only.

| Bit Position | Value | Description |
|---------------|-------|---|
| [7:6] TRIG | 00 | Receive FIFO trigger level set to 1. Receive data interrupt is generated when there is 1 byte in the FIFO. Valid only if FIFO is enabled. |
| | 01 | Receive FIFO trigger level set to 4. Receive data interrupt is generated when there are 4bytes in the FIFO. Valid only if FIFO is enabled. |
| | 10 | Receive FIFO trigger level set to 8. Receive data interrupt is generated when there are 8 bytes in the FIFO. Valid only if FIFO is enabled. |
| | 11 | Receive FIFO trigger level set to 14. Receive data interrupt is generated when there are 14 bytes in the FIFO. Valid only if FIFO is enabled. |
| [5:3] | 000b | Reserved—must be 000b. |
| 2 CLRTxF | 0 | No effect. |
| | 1 | Clear the transmit FIFO and reset the transmit FIFO pointer. Valid only if the FIFO is enabled. |
| 1 CLRRxF | 0 | No effect. |
| | 1 | Clear the receive FIFO, clear the receive error FIFO, and reset the receive FIFO pointer. Valid only if the FIFO is enabled. |
| 0 FIFOEN | 0 | Transmit and receive FIFOs are disabled. Transmit and receive buffers are only 1 byte deep. |
| | 1 | Transmit and receive FIFOs are enabled. Note: Receive FIFO will not be enabled during Multidrop Mode. |



UART Line Control Register

This register is used to control the communication control parameters. See Tables 102 and 103.

Table 102. UART Line Control Registers
(UART0_LCTL = 00C3h, UART1_LCTL = 00D3h)

| Bit | 7 | 6 | 5 | 4 | 3 | 2 | 1 | 0 |
|-------------------|-----|-----|-----|-----|-----|-----|-----|-----|
| Reset | 0 | 0 | 0 | 0 | 0 | 0 | 0 | 0 |
| CPU Access | R/W | R/W | R/W | R/W | R/W | R/W | R/W | R/W |

Note: R/W = Read/Write.

| Bit Position | Value | Description |
|--------------|-------|---|
| 7 DLAB | 0 | Access to the UART registers at I/O addresses C0h, C1h, D0h and D1h is enabled. |
| | 1 | Access to the Baud Rate Generator registers at I/O addresses C0h, C1h, D0h and D1h is enabled. |
| 6 SB | 0 | Do not send a BREAK signal. |
| | 1 | Send Break UART sends continuous zeroes on the transmit output from the next bit boundary. The transmit data in the transmit shift register is ignored. After forcing this bit High, the TxD output is 0 only after the bit boundary is reached. Just before forcing TxD to 0, the transmit FIFO is cleared. Any new data written to the transmit FIFO during a break should be written only after the THRE bit of UARTx_LSR register goes High. This new data is transmitted after the UART recovers from the break. After the break is removed, the UART recovers from the break for the next BRG edge. |
| 5 FPE | 0 | Do not force a parity error. |
| | 1 | Force a parity error. When this bit and the party enable bit (pen) are both 1, an incorrect parity bit is transmitted with the data byte. |



| Bit Position | Value | Description |
|---------------|-------------|---|
| 4 EPS | 0 | Even Parity Select Use odd parity for transmit and receive. The total number of 1 bits in the transmit data plus parity bit is odd. Used as SPACE bit in Multidrop Mode. See Table 104 for parity select definitions. Note: Receive Parity is set to SPACE in multidrop mode. |
| | 1 | Use even parity for transmit and receive. The total number of 1 bits in the transmit data plus parity bit is even. Used as MARK bit in Multidrop Mode. See Table 104 for parity select definitions. |
| 3 PEN | 0 | Parity bit transmit and receive is disabled. |
| | 1 | Parity bit transmit and receive is enabled. For transmit, a parity bit is generated and transmitted with every data character. For receive, the parity is checked for every incoming data character. In Multidrop Mode, receive parity is checked for space parity. |
| [2:0] CHAR | 000– 111 | UART Character Parameter Selection See Table 103 for a description of the values. |

Table 103. UART Character Parameter Definition

| CHAR[2:0] | Character Length (Tx/Rx Data Bits) | Stop Bits (Tx Stop Bits) |
|-----------|---------------------------------------|-----------------------------|
| 000 | 5 | 1 |
| 001 | 6 | 1 |
| 010 | 7 | 1 |
| 011 | 8 | 1 |
| 100 | 5 | 2 |
| 101 | 6 | 2 |
| 110 | 7 | 2 |
| 111 | 8 | 2 |



Table 104. Parity Select Definition for Multidrop Communications

| Multidrop Mode | Even Parity Select | Parity Type |
|----------------|--------------------|-------------|
| 0 | 0 | odd |
| 0 | 1 | even |
| 1 | 0 | space |
| 1 | 1* | mark |

Note: *In Multidrop Mode, EPS resets to 0 after the first character is sent.

UART Modem Control Register

This register is used to control and check the modem status. See Table 105.

Table 105. UART Modem Control Registers
(UART0_MCTL = 00C4h, UART1_MCTL = 00D4h)

| Bit | 7 | 6 | 5 | 4 | 3 | 2 | 1 | 0 |
|-------------------|---|-----|-----|-----|-----|-----|-----|-----|
| Reset | 0 | 0 | 0 | 0 | 0 | 0 | 0 | 0 |
| CPU Access | R | R/W | R/W | R/W | R/W | R/W | R/W | R/W |

Note: R = Read Only; R/W = Read/Write.

| Bit Position | Value | Description |
|---------------|-------|--|
| 7 | 0 | Reserved |
| 6 POLARITY | 0 | TxD and RxD signals—Normal Polarity. |
| | 1 | Invert Polarity of TxD and RxD signals. |
| 5 MDM | 0 | Multidrop Mode disabled. |
| | 1 | Multidrop Mode enabled. See Table 104 for parity select definitions. |



| Bit Position | Value | Description |
|--------------|-------|--|
| 4 LOOP | 0 | LOOP BACK mode is not enabled. |
| | 1 | LOOP BACK mode is enabled. The UART operates in internal LOOP BACK mode. The transmit data output port is disconnected from the internal transmit data output and set to 1. The receive data input port is disconnected and internal receive data is connected to internal transmit data. The modem status input ports are disconnected and the four bits of the modem control register are connected as modem status inputs. The two modem control output ports (OUT1&2) are set to their inactive state |
| 3 OUT2 | 0–1 | No function in normal operation. In LOOP BACK mode, this bit is connected to the DCD bit in the UART Status Register. |
| 2 OUT1 | 0–1 | No function in normal operation. In LOOP BACK mode, this bit is connected to the RI bit in the UART Status Register. |
| 1 RTS | 0–1 | Request to Send _____ In normal operation, the RTS output port is the inverse of this bit. In LOOP BACK mode, this bit is connected to the CTS bit in the UART Status Register. |
| 0 DTR | 0–1 | Data Terminal Ready. _____ In normal operation, the DTR output port is the inverse of this bit. In LOOP BACK mode, this bit is connected to the DSR bit in the UART Status Register. |

www.DataSheet4U.com



UART Line Status Register

This register is used to show the status of UART interrupts and registers. See Table 106.

Table 106. UART Line Status Registers
(UART0_LSR = 00C5h, UART1_LSR = 00D5h)

| Bit | 7 | 6 | 5 | 4 | 3 | 2 | 1 | 0 |
|-------------------|---|---|---|---|---|---|---|---|
| Reset | 0 | 1 | 1 | 0 | 0 | 0 | 0 | 0 |
| CPU Access | R | R | R | R | R | R | R | R |

Note: R = Read only.

| Bit Position | Value | Description |
|--------------|-------|---|
| 7 ERR | 0 | Always 0 when operating in with the FIFO disabled. With the FIFO enabled, this bit is reset when the UARTx_LSR register is read and there are no more bytes with error status in the FIFO. |
| | 1 | Error detected in the FIFO. There is at least 1 parity, framing or break indication error in the FIFO. |
| 6 TEMT | 0 | Transmit holding register/FIFO is not empty or transmit shift register is not empty or transmitter is not idle. |
| | 1 | Transmit holding register/FIFO and transmit shift register are empty; and the transmitter is idle. This bit cannot be set to 1 during the BREAK condition. This bit only becomes 1 after the BREAK command is removed. |
| 5 THRE | 0 | Transmit holding register/FIFO is not empty. |
| | 1 | Transmit holding register/FIFO. This bit cannot be set to 1 during the BREAK condition. This bit only becomes 1 after the BREAK command is removed. |
| 4 BI | 0 | Receiver does not detect a BREAK condition. This bit is reset to 0 when the UARTx_LSR register is read. |
| | 1 | Receiver detects a BREAK condition on the receive input line. This bit is 1 if the duration of BREAK condition on the receive data is longer than one character transmission time, the time depends on the programming of the UARTx_LSR register. In case of FIFO only one null character is loaded into the receiver FIFO with the framing error. The framing error is revealed to the eZ80 whenever that particular data is read from the receiver FIFO. |



| Bit Position | Value | Description |
|--------------|-------|---|
| 3 FE | 0 | No framing error detected for character at the top of the FIFO. This bit is reset to 0 when the UARTx_LSR register is read. |
| | 1 | Framing error detected for the character at the top of the FIFO. This bit is set to 1 when the stop bit following the data/parity bit is logic 0. |
| 2 PE | 0 | The received character at the top of the FIFO does not contain a parity error. In multidrop mode, this indicates that the received character is a data byte. This bit is reset to 0 when the UARTx_LSR register is read. |
| | 1 | The received character at the top of the FIFO contains a parity error. In multidrop mode, this indicates that the received character is an address byte. |
| 1 OE | 0 | The received character at the top of the FIFO does not contain an overrun error. This bit is reset to 0 when the UARTx_LSR register is read. |
| | 1 | Overrun error is detected. If the FIFO is not enabled, this indicates that the data in the receive buffer register was not read before the next character was transferred into the receiver buffer register. If the FIFO is enabled, this indicates the FIFO was already full when an additional character was received by the receiver shift register. The character in the receiver shift register is not put into the receiver FIFO. |
| 0 DR | 0 | This bit is reset to 0 when the UARTx_RBR register is read or all bytes are read from the receiver FIFO. |
| | 1 | Data ready. If the FIFO is not enabled, this bit is set to 1 when a complete incoming character is transferred into the receiver buffer register from the receiver shift register. If the FIFO is enabled, this bit is set to 1 when a character is received and transferred to the receiver FIFO. |

www.DataSheet4U.com

UART Modem Status Register

This register is used to show the status of the UART signals. See Table 107.

Table 107. UART Modem Status Registers
(UART0_MSR = 00C6h, UART1_MSR = 00D6h)

| Bit | 7 | 6 | 5 | 4 | 3 | 2 | 1 | 0 |
|-------------------|---|---|---|---|---|---|---|---|
| Reset | X | X | X | X | X | X | X | X |
| CPU Access | R | R | R | R | R | R | R | R |

Note: R = Read only.

| Bit Position | Value | Description |
|--------------|-------|---|
| 7 DCD | 0–1 | Data Carrier Detect In <u>NORMAL</u> mode, this bit reflects the inverted state of the DCDx input pin. In LOOP BACK mode, this bit reflects the value of the UARTx_MCTL[3] = out2. |
| 6 RI | 0–1 | Ring Indicator In <u>NORMAL</u> mode, this bit reflects the inverted state of the RIx input pin. In LOOP BACK mode, this bit reflects the value of the UARTx_MCTL[2] = out1. |
| 5 DSR | 0–1 | Data Set Ready In <u>NORMAL</u> mode, this bit reflects the inverted state of the DSRx input pin. In LOOP BACK mode, this bit reflects the value of the UARTx_MCTL[0] = DTR. |
| 4 CTS | 0–1 | Clear to Send In <u>NORMAL</u> mode, this bit reflects the inverted state of the CTSx input pin. In LOOP BACK mode, this bit reflects the value of the UARTx_MCTL[1] = RTS. |
| 3 DDCD | 0–1 | Delta Status Change of DCD This bit is set to 1 whenever the DCDx pin changes state. This bit is reset to 0 when the UARTx_MSR register is read. |
| 2 TERI | 0–1 | Trailing Edge Change on RI. This bit is set to 1 whenever a falling edge is detected on the RIx pin. This bit is reset to 0 when the UARTx_MSR register is read. |
| 1 DDSR | 0–1 | Delta Status Change of DSR This bit is set to 1 whenever the DSRx pin changes state. This bit is reset to 0 when the UARTx_MSR register is read. |
| 0 DCTS | 0–1 | Delta Status Change of CTS This bit is set to 1 whenever the CTSx pin changes state. This bit is reset to 0 when the UARTx_MSR register is read. |



UART Scratch Pad Register

The UARTx_SPR register can be used by the system as a general-purpose Read/Write register. See Table 108.

Table 108. UART Scratch Pad Registers
(UART0_SPR = 00C7h, UART1_SPR = 00D7h)

| Bit | 7 | 6 | 5 | 4 | 3 | 2 | 1 | 0 |
|-------------------|-----|-----|-----|-----|-----|-----|-----|-----|
| Reset | 0 | 0 | 0 | 0 | 0 | 0 | 0 | 0 |
| CPU Access | R/W | R/W | R/W | R/W | R/W | R/W | R/W | R/W |

Note: R/W = Read/Write.

| Bit Position | Value | Description |
|--------------|---------|--|
| [7:0] SPR | 00h–FFh | UART scratch pad register is available for use as a general-purpose Read/Write register. |

Infrared Encoder/Decoder

The eZ80F91 device contains a UART to an infrared encoder/decoder (endec). The endec is integrated with the on-chip UART0 to allow easy communication between the CPU and IrDA Physical Layer Specification Version 1.4-compatible infrared transceivers, as illustrated in Figure 36. Infrared communication provides secure, reliable, high-speed, low-cost, point-to-point communication between PCs, PDAs, mobile telephones, printers and other infrared-enabled devices.

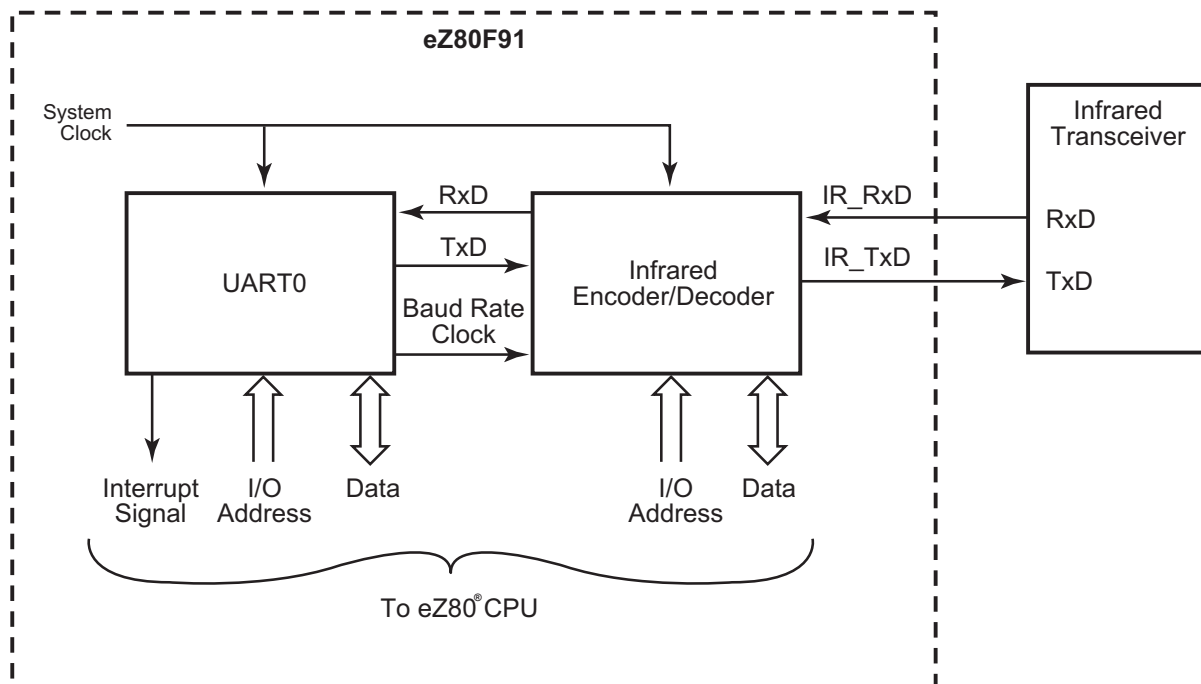

Figure 36. Infrared System Block Diagram

Functional Description

When the endec is enabled, the transmit data from the on-chip UART is encoded as digital signals in accordance with the IrDA standard and output to the infrared transceiver. Likewise, data received from the infrared transceiver is decoded by the endec and passed to the UART. Communication is half-duplex, meaning that simultaneous data transmission and reception is not allowed.

The baud rate is set by the UART Baud Rate Generator, which supports IrDA standard baud rates from 9600 bits/s to 115.2 KBPS. Higher baud rates are possi-

ble, but do not meet IrDA specifications. The UART must be enabled to use the endec. Refer to the section covering the [Universal Asynchronous Receiver/Transmitter](#) on page 183 for more information on the UART and its Baud Rate Generator.

Transmit

The data to be transmitted via the IR transceiver is first data sent to UART0. The UART transmit signal, Tx_D, and Baud Rate Clock are used by the endec to generate the modulation signal, IR_{TxD}, that drives the infrared transceiver. Each UART bit is 16 clocks wide. If the data to be transmitted is a logical 1 (High), the IR_{TxD} signal remains Low (0) for the full 16-clock period. If the data to be transmitted is a logical 0, a 3-clock High (1) pulse is output following a 7-clock Low (0) period. Following the 3-clock High pulse, a 6-clock Low pulse completes the full 16-clock data period. Data transmission is illustrated in Figure 37. During data transmission, the IR receive function should be disabled by clearing the IR_{RxEN} bit in the IR_{CTL} reg to 0 to prevent transmitter-to-receiver crosstalk.

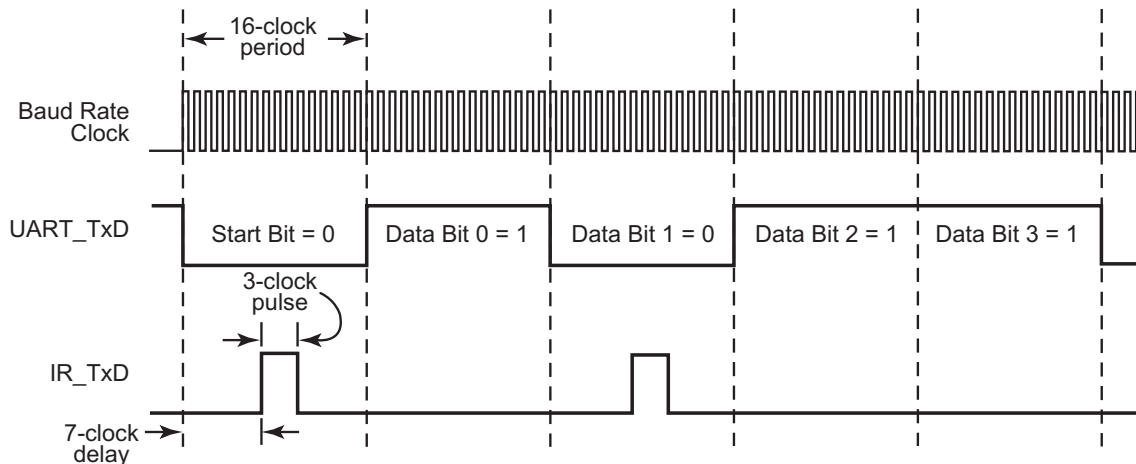

Figure 37. Infrared Data Transmission

Receive

Data received from the IR transceiver via the IR_{RxD} signal is decoded by the endec and passed to the UART. The IR_{RxEN} bit in the IR_{CTL} register must be set to enable the receiver decoder. The SIR data format uses half duplex communication. Therefore, the UART should not be allowed to transmit while the receiver decoder is enabled. The UART Baud Rate Clock is used by the endec to generate the demodulated signal, Rx_D, that drives the UART. Each UART bit is 16 clocks wide. If the data to be received is a logical 1 (High), the IR_{RxD} signal remains

High (1) for the full 16-clock period. If the data to be received is a logical 0, a 3-clock Low (0) pulse is output following a 7-clock High (1) period. Following the 3-clock Low pulse is a 6-clock High pulse to complete the full 16-clock data period. Data transmission is illustrated in Figure 38.

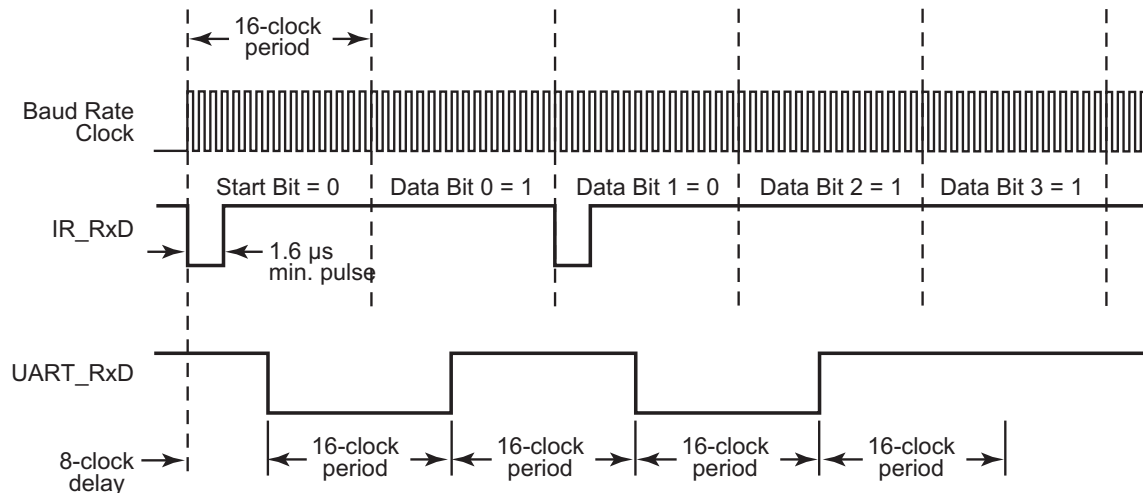

Figure 38. Infrared Data Reception

- **Note:** The infrared encoder/decoder samples the incoming IR pulses using the baud rate clock divided by 16. This sampling rate can be insufficient to capture the incoming pulses when they use a short pulse (1.6 μs) format and low data rates. When the external transmitter sends a short pulse of 3 clocks of 16 clock periods (IR_RxD), the infrared encoder/decoder receives the data properly.

Jitter

Due to the inherent sampling of the received IR_RxD signal by the Bit Rate Clock, some jitter can be expected on the first bit in any sequence of data. However, all subsequent bits in the received data stream are a fixed 16 clock periods wide.

Infrared Encoder/Decoder Signal Pins

The endec signal pins, IR_TxD and IR_RxD, are multiplexed with General-Purpose I/O (GPIO) pins. These GPIO pins must be configured for alternate function operation for the endec to operate.

The remaining six UART0 pins, $\overline{\text{CTS0}}$, $\overline{\text{DCD0}}$, $\overline{\text{DSR0}}$, $\overline{\text{DTR0}}$, $\overline{\text{RTS}}$ and $\overline{\text{RI0}}$, are not required for use with the endec. The UART0 modem status interrupt should be disabled to prevent unwanted interrupts from these pins. The GPIO pins corresponding to these six unused UART0 pins can be used for inputs, outputs, or



interrupt sources. Recommended GPIO Port D control register settings are provided in Table 109. Refer to the section covering the [General-Purpose Input/Output](#), on page 58 for additional information on setting the GPIO Port modes.

Table 109. GPIO Mode Selection when using the IrDA Encoder/Decoder

| GPIO Port D Bits | Allowable GPIO Port Mode | Allowable Port Mode Functions |
|------------------|--|--|
| PD0 | 7 | Alternate Function |
| PD1 | 7 | Alternate Function |
| PD2–PD7 | Any other than GPIO Mode 7 (1, 2, 3, 4, 5, 6, 8, or 9) | Output, Input, Open-Drain, Open-Source, Level-sensitive Interrupt Input, or Edge-Triggered Interrupt Input |

Loopback Testing

Both internal and external loopback testing can be accomplished with the endec on the eZ80F91 device. Internal loopback testing is enabled by setting the LOOP_BACK bit to 1. During internal loopback, the IR_TxD output signal is inverted and connected on-chip to the IR_RxD input. External loopback testing of the off-chip IrDA transceiver can be accomplished by transmitting data from the UART while the receiver is enabled (IR_RxEN set to 1).

Infrared Encoder/Decoder Register

After a RESET, the Infrared Encoder/Decoder Register is set to its default value. Any Writes to unused register bits are ignored and reads return a value of 0. The IR_CTL register is described in Table 110.

Table 110. Infrared Encoder/Decoder Control Registers (IR_CTL = 00BFh)

| Bit | 7 | 6 | 5 | 4 | 3 | 2 | 1 | 0 |
|-------------------|---|---|---|---|---|-----|-----|-----|
| Reset | 0 | 0 | 0 | 0 | 0 | 0 | 0 | 0 |
| CPU Access | R | R | R | R | R | R/W | R/W | R/W |

Note: R = Read only; R/W = Read/Write.

| Bit Position | Value | Description |
|--------------|-------|-------------|
| [7:3] | 00000 | Reserved. |



| Bit Position | Value | Description |
|----------------|-------|--|
| 2 LOOP_BACK | 0 | Internal LOOP BACK mode is disabled. |
| | 1 | Internal LOOP BACK mode is enabled. IR_TxD output is inverted and connected to IR_RxD input for internal loop back testing. |
| 1 IR_RxEN | 0 | IR_RxD data is ignored. |
| | 1 | IR_RxD data is passed to UART0 RxD. |
| 0 IR_EN | 0 | Endec is disabled. |
| | 1 | Endec is enabled. |

www.DataSheet4U.com

Serial Peripheral Interface

The Serial Peripheral Interface (SPI) is a synchronous interface allowing several SPI-type devices to be interconnected. The SPI is a full-duplex, synchronous, character-oriented communication channel that employs a four-wire interface. The SPI block consists of a transmitter, receiver, baud rate generator, and control unit. During an SPI transfer, data is sent and received simultaneously by both the master and the slave SPI devices.

In a serial peripheral interface, separate signals are required for data and clock. The SPI can be configured as either a master or a slave. The connection of two SPI devices (one master and one slave) and the direction of data transfer is demonstrated in Figures 39 and 40 .

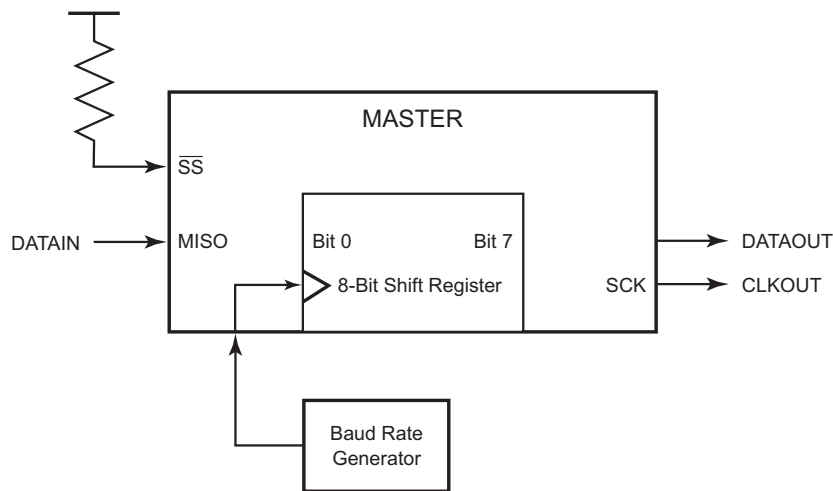

Figure 39. SPI Master Device

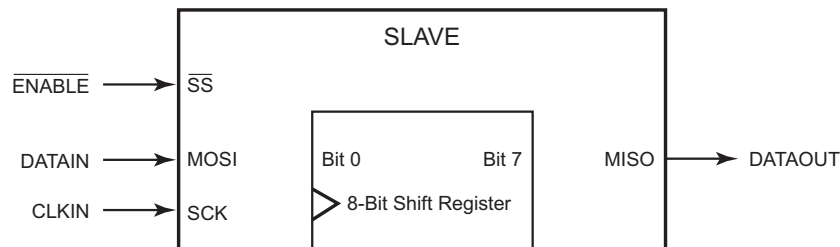

Figure 40. SPI Slave Device

SPI Signals

The four basic SPI signals are:

- MISO (Master In, Slave Out)
- MOSI (Master Out, Slave In)
- SCK (SPI Serial Clock)
- $\overline{\text{SS}}$ (Slave Select)

These SPI signals are discussed in the following paragraphs. Each signal is described in both MASTER and SLAVE modes.

Master In, Slave Out

The Master In, Slave Out (MISO) pin is configured as an input in a master device and as an output in a slave device. It is one of the two lines that transfer serial data, with the most-significant bit sent first. The MISO pin of a slave device is placed in a high-impedance state if the slave is not selected. When the SPI is not enabled, this signal is in a high-impedance state.

Master Out, Slave In

The Master Out, Slave In (MOSI) pin is configured as an output in a master device and as an input in a slave device. It is one of the two lines that transfer serial data, with the most-significant bit sent first. When the SPI is not enabled, this signal is in a high-impedance state.

Slave Select

The active Low Slave Select ($\overline{\text{SS}}$) input signal is used to select the SPI as a slave device. It must be Low prior to all data communication and must stay Low for the duration of the data transfer.

The $\overline{\text{SS}}$ input signal must be High for the SPI to operate as a master device. If the $\overline{\text{SS}}$ signal goes Low, a Mode Fault error flag (MODF) is set in the SPI_SR register. See the [SPI Status Register](#) (SPI_SR) on page 217 for more information.

When the Clock Phase (CPHA) is set to 0, the shift clock is the logical OR of $\overline{\text{SS}}$ with SCK. In this clock phase mode, $\overline{\text{SS}}$ must go High between successive characters in an SPI message. When CPHA is set to 1, $\overline{\text{SS}}$ can remain Low for several SPI characters. In cases where there is only one SPI slave, its $\overline{\text{SS}}$ line could be tied Low as long as CPHA is set to 1. See the [SPI Control Register](#) (SPI_CTL) on page 216 for more information on CPHA.

Serial Clock

The Serial Clock (SCK) is used to synchronize data movement both in and out of the device via its MOSI and MISO pins. The master and slave are each capable of

exchanging a byte of data during a sequence of eight clock cycles. Because SCK is generated by the master, the SCK pin becomes an input on a slave device. The SPI contains an internal divide-by-two clock divider. In MASTER mode, the SPI serial clock is one-half the frequency of the clock signal created by the SPI's Baud Rate Generator.

As demonstrated in Figure 41 and Table 111, four possible timing relations can be chosen by using the clock polarity (CPOL) and CPHA control bits in the SPI Control register. See the [SPI Control Register \(SPI_CTL\)](#) on page 216. Both the master and slave must operate with the identical timing, CPOL, and CPHA. The master device always places data on the MOSI line a half-cycle before the clock edge (SCK signal), for the slave device to latch the data.

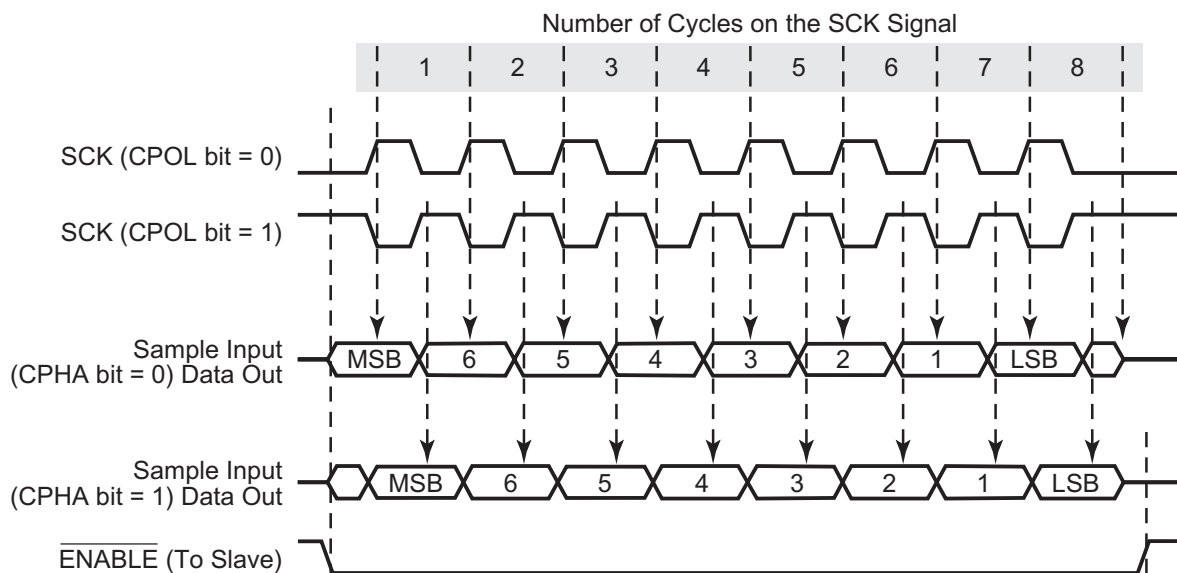

Figure 41. SPI Timing

Table 111. SPI Clock Phase and Clock Polarity Operation

| CPHA | CPOL | SCK Transmit Edge | SCK Receive Edge | SCK Idle State | SS High Between Characters? |
|------|------|-------------------|------------------|----------------|-----------------------------|
| 0 | 0 | Falling | Rising | Low | Yes |
| 0 | 1 | Rising | Falling | High | Yes |



Table 111. SPI Clock Phase and Clock Polarity Operation (Continued)

| CPHA | CPOL | SCK Transmit Edge | SCK Receive Edge | SCK Idle State | $\overline{\text{SS}}$ High Between Characters? |
|------|------|-------------------|------------------|----------------|---|
| 1 | 0 | Rising | Falling | Low | No |
| 1 | 1 | Falling | Rising | High | No |

www.DataSheet4U.com

SPI Functional Description

When a master transmits to a slave device via the MOSI signal, the slave device responds by sending data to the master via the master's MISO signal. The resulting implication is a full-duplex transmission, with both *data out* and *data in* synchronized with the same clock signal. As a result, the byte transmitted is replaced by the byte received to eliminate the requirement for separate transmit-empty and receive-full status bits. A single status bit, SPIF, is used to signify that the I/O operation is complete. See the [SPI Status Register](#) (SPI_SR) on page 217.

The SPI is double-buffered during reads, but not during Writes. If a Write is performed during data transfer, the transfer occurs uninterrupted, and the Write is unsuccessful. This condition causes the write collision (WCOL) status bit in the SPI_SR register to be set. After a data byte is shifted, the SPIF flag of the SPI_SR register is set to 1.

In SPI MASTER mode, the SCK pin functions as an output. It idles High or Low depending on the CPOL bit in the SPI_CTL register until data is written to the shift register. Data transfer is initiated by writing to the transmit shift register, SPI_TSR. Eight clocks are then generated to shift the eight bits of transmit data out via the MOSI pin while shifting in eight bits of data via the MISO pin. After transfer, the SCK signal becomes idle.

In SPI SLAVE mode, the start logic receives a logic Low from the $\overline{\text{SS}}$ pin and a clock input at the SCK pin; as a result, the slave is synchronized to the master. Data from the master is received serially from the slave MOSI signal and is loaded into the 8-bit shift register. After the 8-bit shift register is loaded, its data is parallel-transferred to the Read buffer. During a Write cycle, data is written into the shift register. Next, the slave waits for the SPI master to initiate a data transfer, supply a clock signal, and shift the data out on the slave's MISO signal.

If the CPHA bit in the SPI_CTL register is 0, a transfer begins when the $\overline{\text{SS}}$ pin signal goes Low. The transfer ends when $\overline{\text{SS}}$ goes High after eight clock cycles on SCK. When the CPHA bit is set to 1, a transfer begins the first time SCK becomes active while $\overline{\text{SS}}$ is Low. The transfer ends when the SPIF flag is set to 1.

SPI Flags

Mode Fault

The Mode Fault flag (MODF) indicates that there can be a multimaster conflict in the system control. The MODF bit is normally cleared to 0 and is only set to 1 when the master device's SS pin is pulled Low. When a mode fault is detected, the following sequence occurs:

1. The MODF flag (SPI_SR[4]) is set to 1.
2. The SPI device is disabled by clearing the SPI_EN bit (SPI_CTL[5]) to 0.
3. The MASTER_EN bit (SPI_CTL[4]) is cleared to 0, forcing the device into SLAVE mode.
4. If the SPI interrupt is enabled by setting IRQ_EN (SPI_CTL[7]) High, an SPI interrupt is generated.

Clearing the Mode Fault flag is performed by reading the SPI Status register. The other SPI control bits (SPI_EN and MASTER_EN) must be restored to their original states by user software after the Mode Fault flag is cleared to 0.

Write Collision

The write collision flag, WCOL (SPI_SR[5]), is set to 1 when an attempt is made to write to the SPI Transmit Shift register (SPI_TSR) while data transfer occurs.

Clearing the WCOL bit is performed by reading SPI_SR with the WCOL bit set to 1.

SPI Baud Rate Generator

The SPI's Baud Rate Generator creates a lower frequency clock from the high-frequency system clock. The Baud Rate Generator output is used as the clock source by the SPI.

Baud Rate Generator Functional Description

The SPI's Baud Rate Generator consists of a 16-bit downcounter, two 8-bit registers, and associated decoding logic. The Baud Rate Generator's initial value is defined by the two BRG Divisor Latch registers {SPI_BRG_H, SPI_BRG_L}. At the rising edge of each system clock, the BRG decrements until it reaches the value 0001h. On the next system clock rising edge, the BRG reloads the initial value from {SPI_BRG_H, SPI_BRG_L} and outputs a pulse to indicate the end of the count.

The SPI Data Rate can be calculated using the following equation:

$$\text{SPI Data Rate (bits/s)} = \frac{\text{System Clock Frequency}}{2 \times \text{SPI Baud Rate Generator Divisor}}$$

Upon RESET, the 16-bit BRG divisor value resets to 0002h. When the SPI is operating as a Master, the BRG divisor value must be set to a value of 0003h or greater. When the SPI is operating as a Slave, the BRG divisor value must be set to a value of 0004h or greater. A software Write to either the Low- or High-byte registers for the BRG Divisor Latch causes both the Low and High bytes to load into the BRG counter, and causes the count to restart.

Data Transfer Procedure with SPI Configured as a Master

The sequence that follows details the procedure for transferring data from a master SPI device to a slave SPI device.

1. Load the SPI Baud Rate Generator Registers, SPI_BRG_H and SPI_BRG_L. The external device must deassert the SS pin if currently asserted.
2. Load the SPI Control Register, SPI_CTL.
3. Assert the ENABLE pin of the slave device using a GPIO pin.
4. Load the SPI Transmit Shift Register, SPI_TSR.
5. When the SPI data transfer is complete, deassert the ENABLE pin of the slave device.

Data Transfer Procedure with SPI Configured as a Slave

The sequence that follows details the procedure for transferring data from a slave SPI device to a master SPI device.

1. Load the SPI Baud Rate Generator Registers, SPI_BRG_H and SPI_BRG_L.
2. Load the SPI Transmit Shift Register, SPI_TSR. This load cannot occur while the SPI slave is currently receiving data.
3. Wait for the external SPI Master device to initiate the data transfer by asserting SS.

SPI Registers

There are six registers in the Serial Peripheral Interface that provide control, status, and data storage functions. The SPI registers are described in the following paragraphs.



SPI Baud Rate Generator Registers—Low Byte and High Byte

These registers hold the Low and High bytes of the 16-bit divisor count loaded by the CPU for baud rate generation. The 16-bit clock divisor value is returned by {SPI_BRG_H, SPI_BRG_L}. Upon RESET, the 16-bit BRG divisor value resets to 0002h. When configured as a Master, the 16-bit divisor value must be between 0003h and FFFFh, inclusive. When configured as a Slave, the 16-bit divisor value must be between 0004h and FFFFh, inclusive.

A Write to either the Low- or High-byte registers for the BRG Divisor Latch causes both bytes to be loaded into the BRG counter and a restart of the count. See Tables 112 and 113.

Table 112. SPI Baud Rate Generator Register—Low Byte (SPI_BRG_L = 00B8h)

| Bit | 7 | 6 | 5 | 4 | 3 | 2 | 1 | 0 |
|------------|-----|-----|-----|-----|-----|-----|-----|-----|
| Reset | 0 | 0 | 0 | 0 | 0 | 0 | 1 | 0 |
| CPU Access | R/W | R/W | R/W | R/W | R/W | R/W | R/W | R/W |

Note: R/W = Read/Write.

| Bit Position | Value | Description |
|--------------------|-------------|--|
| [7:0] SPI_BRG_L | 00h– FFh | These bits represent the Low byte of the 16-bit Baud Rate Generator divider value. The complete BRG divisor value is returned by {SPI_BRG_H, SPI_BRG_L}. |

Table 113. SPI Baud Rate Generator Register—High Byte (SPI_BRG_H = 00B9h)

| Bit | 7 | 6 | 5 | 4 | 3 | 2 | 1 | 0 |
|------------|-----|-----|-----|-----|-----|-----|-----|-----|
| Reset | 0 | 0 | 0 | 0 | 0 | 0 | 0 | 0 |
| CPU Access | R/W | R/W | R/W | R/W | R/W | R/W | R/W | R/W |

Note: R/W = Read/Write.

| Bit Position | Value | Description |
|--------------------|-------------|---|
| [7:0] SPI_BRG_H | 00h– FFh | These bits represent the High byte of the 16-bit Baud Rate Generator divider value. The complete BRG divisor value is returned by {SPI_BRG_H, SPI_BRG_L}. |



SPI Control Register

This register is used to control and setup the serial peripheral interface. The SPI should be disabled prior to making any changes to CPHA or CPOL. See Table 114.

**Table 114. SPI Control Register
(SPI_CTL = 00BAh)**

| Bit | 7 | 6 | 5 | 4 | 3 | 2 | 1 | 0 |
|-------------------|-----|---|-----|-----|-----|-----|---|---|
| Reset | 0 | 0 | 0 | 0 | 0 | 1 | 0 | 0 |
| CPU Access | R/W | R | R/W | R/W | R/W | R/W | R | R |

Note: R = Read Only; R/W = Read/Write.

| Bit Position | Value | Description |
|----------------|-------|--|
| 7 IRQ_EN | 0 | SPI system interrupt is disabled. |
| | 1 | SPI system interrupt is enabled. |
| 6 | 0 | Reserved. |
| 5 SPI_EN | 0 | SPI is disabled. |
| | 1 | SPI is enabled. |
| 4 MASTER_EN | 0 | When enabled, the SPI operates as a slave. |
| | 1 | When enabled, the SPI operates as a master. |
| 3 CPOL | 0 | Master SCK pin idles in a Low (0) state. |
| | 1 | Master SCK pin idles in a High (1) state. |
| 2 CPHA | 0 | \overline{SS} must go High after transfer of every byte of data. |
| | 1 | \overline{SS} can remain Low to transfer any number of data bytes. |
| [1:0] | 00 | Reserved. |



SPI Status Register

The SPI Status Read Only register returns the status of data transmitted using the serial peripheral interface. Reading the SPI_SR register clears Bits 7, 6, and 4 to a logical 0. See Table 115.

Table 115. SPI Status Register
(SPI_SR = 00BBh)

| Bit | 7 | 6 | 5 | 4 | 3 | 2 | 1 | 0 |
|------------|---|---|---|---|---|---|---|---|
| Reset | 0 | 0 | 0 | 0 | 0 | 0 | 0 | 0 |
| CPU Access | R | R | R | R | R | R | R | R |

Note: R = Read Only.

| Bit Position | Value | Description |
|--------------|-------|---|
| 7 SPIF | 0 | SPI data transfer is not finished. |
| | 1 | SPI data transfer is finished. If enabled, an interrupt is generated. This bit flag is cleared to 0 by a Read of the SPI_SR register. |
| 6 WCOL | 0 | An SPI write collision is not detected. |
| | 1 | An SPI write collision is detected. This bit flag is cleared to 0 by a Read of the SPI_SR registers. |
| 5 | 0 | Reserved. |
| 4 MODF | 0 | A mode fault (multimaster conflict) is not detected. |
| | 1 | A mode fault (multimaster conflict) is detected. This bit flag is cleared to 0 by a Read of the SPI_SR register. |
| [3:0] | 0000 | Reserved. |

SPI Transmit Shift Register

The SPI Transmit Shift register (SPI_TSR) is used by the SPI master to transmit data over SPI serial bus to the slave device. A Write to the SPI_TSR register places data directly into the shift register for transmission. A Write to this register within an SPI device configured as a master initiates transmission of the byte of the data loaded into the register. At the completion of transmitting a byte of data, the SPIF status bit (SPI_SR[7]) is set to 1 in both the master and slave devices.

The SPI Transmit Shift Write Only register shares the same address space as the SPI Receive Buffer Read Only register. See Table 116.



**Table 116. SPI Transmit Shift Register
(SPI_TSR = 00BCh)**

| Bit | 7 | 6 | 5 | 4 | 3 | 2 | 1 | 0 |
|-------------------|---|---|---|---|---|---|---|---|
| Reset | X | X | X | X | X | X | X | X |
| CPU Access | W | W | W | W | W | W | W | W |

Note: W = Write Only.

| Bit Position | Value | Description |
|------------------|-------------|--------------------|
| [7:0] TX_DATA | 00h– FFh | SPI transmit data. |

SPI Receive Buffer Register

The SPI Receive Buffer register (SPI_RBR) is used by the SPI slave to receive data from the serial bus. The SPIF bit must be cleared prior to a second transfer of data from the shift register; otherwise, an overrun condition exists. In the event of an overrun, the byte that causes the overrun is lost.

The SPI Receive Buffer Read Only register shares the same address space as the SPI Transmit Shift Write Only register. See Table 117.

**Table 117. SPI Receive Buffer Register
(SPI_RBR = 00BCh)**

| Bit | 7 | 6 | 5 | 4 | 3 | 2 | 1 | 0 |
|-------------------|---|---|---|---|---|---|---|---|
| Reset | X | X | X | X | X | X | X | X |
| CPU Access | R | R | R | R | R | R | R | R |

Note: R = Read Only.

| Bit Position | Value | Description |
|------------------|-------------|--------------------|
| [7:0] RX_DATA | 00h– FFh | SPI received data. |

I²C Serial I/O Interface

I²C General Characteristics

The Inter-Integrated Circuit (I²C) serial I/O bus is a two-wire communication interface that can operate in four modes:

- MASTER TRANSMIT
- MASTER RECEIVE
- SLAVE TRANSMIT
- SLAVE RECEIVE

The I²C interface consists of a Serial Clock (SCL) and Serial Data (SDA). Both SCL and SDA are bidirectional lines connected to a positive supply voltage via an external pull-up resistor. When the bus is free, both lines are High. The output stages of devices connected to the bus must be configured as open-drain outputs. Data on the I²C bus can be transferred at a rate of up to 100kbps in STANDARD mode, or up to 400kbps in FAST mode. One clock pulse is generated for each data bit transferred.

Clocking Overview

If another device on the I²C bus drives the clock line when the I²C is in MASTER mode, the I²C synchronizes its clock to the I²C bus clock. The High period of the clock is determined by the device that generates the shortest High clock period. The Low period of the clock is determined by the device that generates the longest Low clock period.

A slave can stretch the Low period of the clock to slow down the bus master. The Low period can also be stretched for handshaking purposes. This result can be accomplished after each bit transfer or each byte transfer. The I²C stretches the clock after each byte transfer until the IFLG bit in the I2C_CTL register is cleared to 0.

Bus Arbitration Overview

In MASTER mode, the I²C checks that each transmitted logic 1 appears on the I²C bus as a logic 1. If another device on the bus overrules and pulls the SDA signal Low, arbitration is lost. If arbitration is lost during the transmission of a data byte or a Not Acknowledge (NACK) bit, the I²C returns to an idle state. If arbitration is lost during the transmission of an address, the I²C switches to SLAVE mode so that it can recognize its own slave address or the general call address.

Data Validity

The data on the SDA line must be stable during the High period of the clock. The High or Low state of the data line can only change when the clock signal on the SCL line is Low, as illustrated in Figure 42.

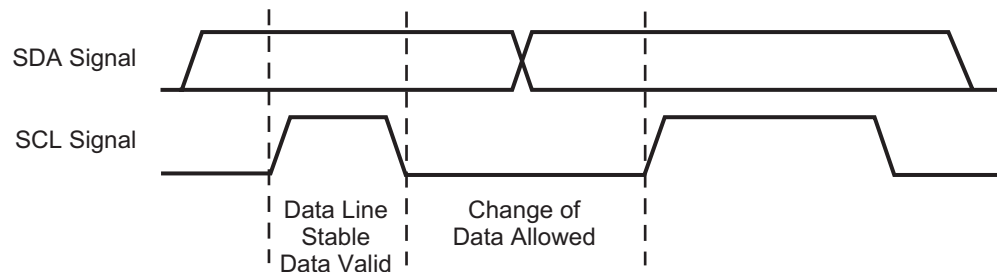

Figure 42. I²C Clock and Data Relationship

START and STOP Conditions

Within the I²C bus protocol, unique situations arise which are defined as START and STOP conditions. Figure 43 illustrates a High-to-Low transition on the SDA line while SCL is High, indicating a START condition. A Low-to-High transition on the SDA line while SCL is High defines a STOP condition.

START and STOP conditions are always generated by the master. The bus is considered to be busy after a START condition. The bus is considered to be free for a defined time after a STOP condition.

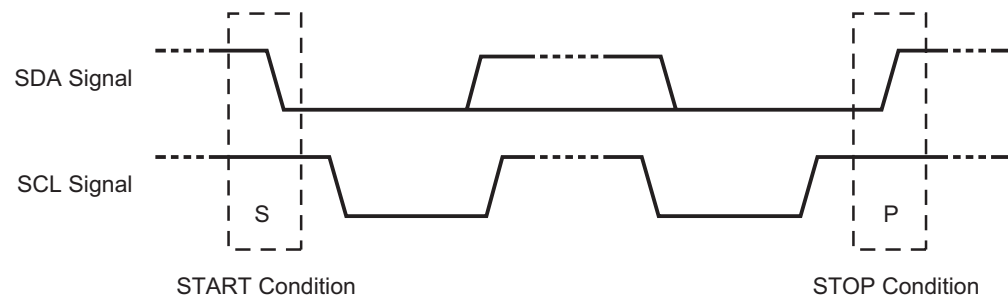

Figure 43. START and STOP Conditions In I²C Protocol

Transferring Data

Byte Format

Every character transferred on the SDA line must be a single 8-bit byte. The number of bytes that can be transmitted per transfer is unrestricted. Each byte must be followed by an Acknowledge (ACK)¹. Data is transferred with the most-significant bit (msb) first. Figure 44 illustrates a receiver that holds the SCL line Low to force the transmitter into a wait state. Data transfer then continues when the receiver is ready for another byte of data and releases SCL.

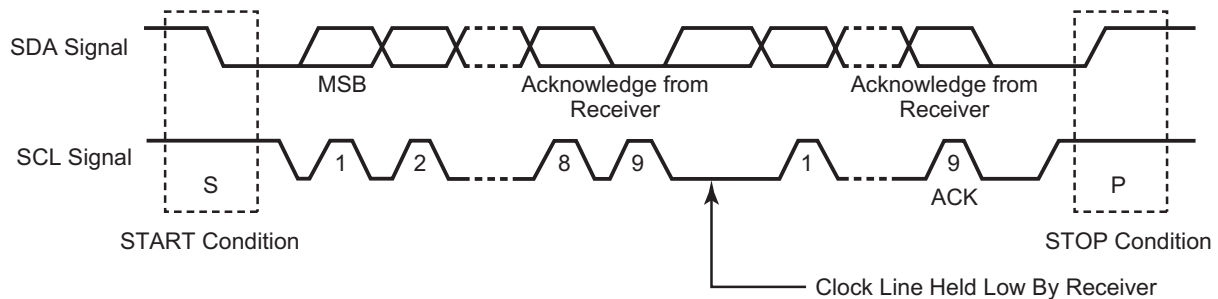

Figure 44. I²C Frame Structure

Acknowledge

Data transfer with an ACK function is obligatory. The ACK-related clock pulse is generated by the master. The transmitter releases the SDA line (High) during the ACK clock pulse. The receiver must pull down the SDA line during the ACK clock pulse so that it remains stable (Low) during the High period of this clock pulse. See Figure 45.

A receiver that is addressed is obliged to generate an ACK after each byte is received. When a slave receiver does not acknowledge the slave address (for example, unable to receive because it is performing some real-time function), the data line must be left High by the slave. The master then generates a STOP condition to abort the transfer.

If a slave receiver acknowledges the slave address, but cannot receive any more data bytes, the master must abort the transfer. The abort is indicated by the slave generating the Not Acknowledge (NACK) on the first byte to follow. The slave leaves the data line High and the master generates the STOP condition.

1. ACK is defined as a general Acknowledge bit. By contrast, the I²C Acknowledge bit is represented as AAK, bit 2 of the I²C Control Register, which identifies which ACK signal to transmit. See [Table 127](#) on page 235.

If a master receiver is involved in a transfer, it must signal the end of the data stream to the slave transmitter by *not* generating an ACK on the final byte that is clocked out of the slave. The slave transmitter must release the data line to allow the master to generate a STOP or a repeated START condition.

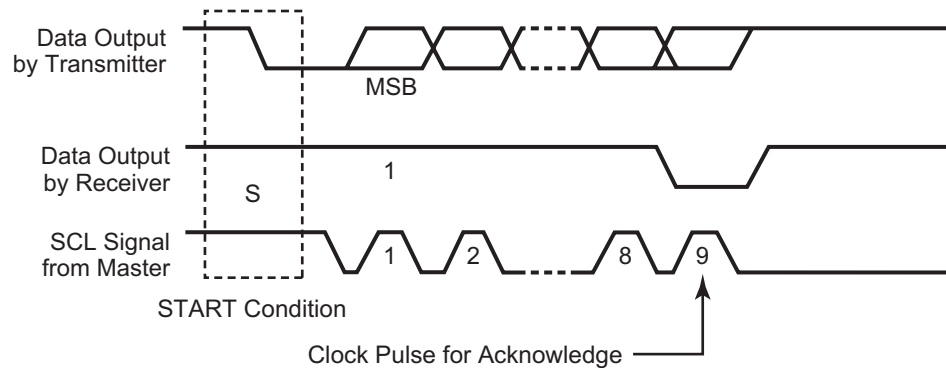

Figure 45. I²C Acknowledge

Clock Synchronization

All masters generate their own clocks on the SCL line to transfer messages on the I²C bus. Data is only valid during the High period of each clock.

Clock synchronization is performed using the wired AND connection of the I²C interfaces to the SCL line, meaning that a High-to-Low transition on the SCL line causes the relevant devices to start counting from their Low period. When a device clock goes Low, it holds the SCL line in that state until the clock High state is reached. See Figure 46. The Low-to-High transition of this clock, however, can not change the state of the SCL line if another clock is still within its Low period. The SCL line is held Low by the device with the longest Low period. Devices with shorter Low periods enter a High wait state during this time.

When all devices count off the Low period, the clock line is released and goes High. There is no difference between the device clocks and the state of the SCL line; all of the devices start counting the High periods. The first device to complete its High period again pulls the SCL line Low. In this way, a synchronized SCL clock is generated with its Low period determined by the device with the longest clock Low period, and its High period determined by the device with the shortest clock High period.

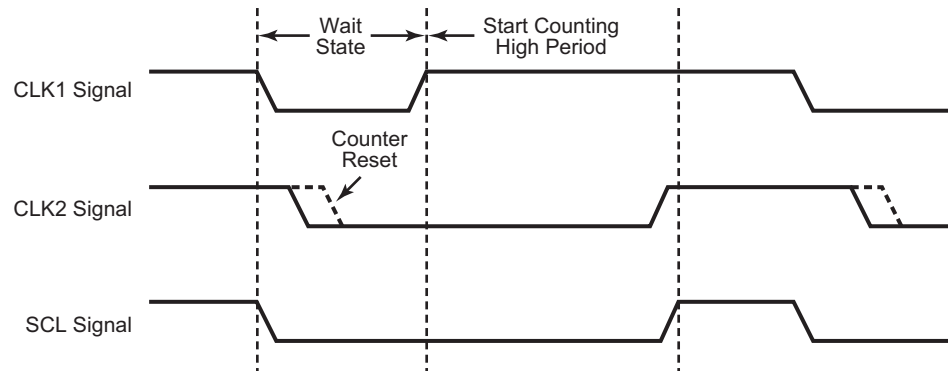

Figure 46. Clock Synchronization In I²C Protocol

Arbitration

Any master can initiate a transfer if the bus is free. As a result, multiple masters can each generate a START condition if the bus is free within a minimum period. If multiple masters generate a START condition, a START is defined for the bus. However, arbitration defines which MASTER controls the bus. Arbitration takes place on the SDA line. As mentioned, START conditions are initiated only while the SCL line is held High. If, during this period, a master (M1) initiates a High-to-Low transition—i.e., a START condition—while a second master (M2) transmits a Low signal on the line, then the first master, M1, cannot take control of the bus. As a result, the data output stage for M1 is disabled.

Arbitration can continue for many bits. Its first stage is comparison of the address bits. If the masters are each trying to address the same device, arbitration continues with a comparison of the data. Because address and data information on the I²C bus is used for arbitration, no information is lost during this process. A master that loses the arbitration can generate clock pulses until the end of the byte in which it loses the arbitration.

If a master also incorporates a slave function and it loses arbitration during the addressing stage, it is possible that the winning master is trying to address it. The losing master must switch over immediately to its slave receiver mode. Figure 46 illustrates the arbitration procedure for two masters. Of course, more can be involved, depending on how many masters are connected to the bus. The moment there is a difference between the internal data level of the master generating DATA 1 and the actual level on the SDA line, its data output is switched off, which means that a High output level is then connected to the bus. As a result, the data transfer initiated by the winning master is not affected. Because control of the I²C bus is decided solely on the address and data sent by competing masters, there is no central master, nor any order of priority on the bus.

Special attention must be paid if, during a serial transfer, the arbitration procedure is still in progress at the moment when a repeated START condition or a STOP condition is transmitted to the I²C bus. If it is possible for such a situation to occur, the masters involved must send this repeated START condition or STOP condition at the same position in the format frame. In other words, arbitration is not allowed between:

- A repeated START condition and a data bit
- A STOP condition and a data bit
- A repeated START condition and a STOP condition

Clock Synchronization for Handshake

The clock-synchronizing mechanism can function as a handshake, enabling receivers to cope with fast data transfers, on either a byte or a bit level. The byte level allows a device to receive a byte of data at a fast rate, but allows the device more time to store the received byte or to prepare another byte for transmission. Slaves hold the SCL line Low after reception and acknowledge the byte, forcing the master into a wait state until the slave is ready for the next byte transfer in a handshake procedure.

Operating Modes

Master Transmit

In MASTER TRANSMIT mode, the I²C transmits a number of bytes to a slave receiver.

Enter MASTER TRANSMIT mode by setting the STA bit in the I2C_CTL register to 1. The I²C then tests the I²C bus and transmits a START condition when the bus is free. When a START condition is transmitted, the IFLG bit is 1 and the status code in the I2C_SR register is 08h. Before this interrupt is serviced, the I2C_DR register must be loaded with either a 7-bit slave address or the first part of a 10-bit slave address, with the lsb cleared to 0 to specify TRANSMIT mode. The IFLG bit should now be cleared to 0 to prompt the transfer to continue.

After the 7-bit slave address (or the first part of a 10-bit address) plus the Write bit are transmitted, the IFLG is set again. A number of status codes are possible in the I2C_SR register. See Table 118.



Table 118. I²C Master Transmit Status Codes

| Code | I ² C State | Microcontroller Response | Next I ² C Action |
|------|--|---|-----------------------------------|
| 18h | Addr+W transmitted ACK received ¹ | For a 7-bit address: write byte to DATA, clear IFLG | Transmit data byte, receive ACK. |
| | | Or set STA, clear IFLG | Transmit repeated START. |
| | | Or set STP, clear IFLG | Transmit STOP. |
| | | Or set STA & STP, clear IFLG | Transmit STOP then START. |
| | | For a 10-bit address: write extended address byte to data, clear IFLG | Transmit extended address byte. |
| 20h | Addr+W transmitted, ACK not received | Same as code 18h | Same as code 18h. |
| 38h | Arbitration lost | Clear IFLG | Return to idle. |
| | | Or set STA, clear IFLG | Transmit START when bus is free. |
| 68h | Arbitration lost, +W received, ACK transmitted | Clear IFLG, AAK = 0 ² | Receive data byte, transmit NACK. |
| | | Or clear IFLG, AAK = 1 | Receive data byte, transmit ACK. |
| 78h | Arbitration lost, General call address received, ACK transmitted | Same as code 68h | Same as code 68h. |
| B0h | Arbitration lost, SLA+R received, ACK transmitted ³ | Write byte to DATA, clear IFLG, clear AAK = 0 | Transmit last byte, receive ACK. |
| | | Or write byte to DATA, clear IFLG, set AAK = 1 | Transmit data byte, receive ACK. |

Notes:

1. W is defined as the Write bit; i.e., the lsb is cleared to 0.
2. AAK is an I²C control bit that identifies which ACK signal to transmit.
3. R is defined as the Read bit; i.e., the lsb is set to 1.

If 10-bit addressing is used, the status code is 18h or 20h after the first part of a 10-bit address, plus the Write bit, are successfully transmitted.

After this interrupt is serviced and the second part of the 10-bit address is transmitted, the I2C_SR register contains one of the codes listed in Table 119.



Table 119. I²C 10-Bit Master Transmit Status Codes

| Code | I ² C State | Microcontroller Response | Next I ² C Action |
|------|--|--|----------------------------------|
| 38h | Arbitration lost | Clear IFLG | Return to idle |
| | | Or set STA, clear IFLG | Transmit START when bus free |
| 68h | Arbitration lost, SLA+W received, ACK transmitted ¹ | Clear IFLG, clear AAK = 0 ² | Receive data byte, transmit NACK |
| | | Or clear IFLG, set AAK = 1 | Receive data byte, transmit ACK |
| B0h | Arbitration lost, SLA+R received, ACK transmitted ³ | Write byte to DATA, clear IFLG, clear AAK = 0 | Transmit last byte, receive ACK |
| | | Or write byte to DATA, clear IFLG, set AAK = 1 | Transmit data byte, receive ACK |
| D0h | Second address byte + W transmitted, ACK received | Write byte to data, clear IFLG | Transmit data byte, receive ACK |
| | | Or set STA, clear IFLG | Transmit repeated START |
| | | Or set STP, clear IFLG | Transmit STOP |
| | | Or set STA & STP, clear IFLG | Transmit STOP then START |
| D8h | Second address byte + W transmitted, ACK not received | Same as code D0h | Same as code D0h |

Notes:

1. W is defined as the Write bit; i.e., the lsb is cleared to 0.
2. AAK is an I²C control bit that identifies which ACK signal to transmit.
3. R is defined as the Read bit; i.e., the lsb is set to 1.

If a repeated START condition is transmitted, the status code is 10h instead of 08h.

After each data byte is transmitted, the IFLG is set to 1 and one of the status codes listed in Table 120 is loaded into the I2C_SR register.



Table 120. I²C Master Transmit Status Codes For Data Bytes

| Code | I ² C State | Microcontroller Response | Next I ² C Action |
|------|--|-----------------------------------|-------------------------------------|
| 28h | Data byte transmitted, ACK received | Write byte to data, clear IFLG | Transmit data byte, receive ACK. |
| | | Or set STA, clear IFLG | Transmit repeated START. |
| | | Or set STP, clear IFLG | Transmit STOP. |
| | | Or set STA & STP, clear IFLG | Transmit START then STOP. |
| 30h | Data byte transmitted, ACK not received | Same as code 28h | Same as code 28h. |
| 38h | Arbitration lost | Clear IFLG | Return to idle. |
| | | Or set STA, clear IFLG | Transmit START when bus free. |

When all bytes are transmitted, the microcontroller should write a 1 to the STP bit in the I2C_CTL register. The I²C then transmits a STOP condition, clears the STP bit and returns to an idle state.

Master Receive

In MASTER RECEIVE mode, the I²C receives a number of bytes from a slave transmitter.

After the START condition is transmitted, the IFLG bit is 1 and the status code 08h is loaded into the I2C_SR register. The I2C_DR register should be loaded with the slave address (or the first part of a 10-bit slave address), with the lsb set to 1 to signify a Read. The IFLG bit should be cleared to 0 as a prompt for the transfer to continue.

When the 7-bit slave address (or the first part of a 10-bit address) and the Read bit are transmitted, the IFLG bit is set and one of the status codes listed in Table 121 is loaded into the I2C_SR register.



Table 121. I²C Master Receive Status Codes

| Code | I ² C State | Microcontroller Response | Next I ² C Action |
|------|--|--|----------------------------------|
| 40h | Addr + R transmitted, ACK received | For a 7-bit address, clear IFLG, AAK = 0 ¹ | Receive data byte, transmit NACK |
| | | Or clear IFLG, AAK = 1 | Receive data byte, transmit ACK |
| | | For a 10-bit address Write extended address byte to data, clear IFLG | Transmit extended address byte |
| 48h | Addr + R transmitted, ACK not received ² | For a 7-bit address: Set STA, clear IFLG | Transmit repeated START |
| | | Or set STP, clear IFLG | Transmit STOP |
| | | Or set STA & STP, clear IFLG | Transmit STOP then START |
| | | For a 10-bit address: Write extended address byte to data, clear IFLG | Transmit extended address byte |
| 38h | Arbitration lost | Clear IFLG | Return to idle |
| | | Or set STA, clear IFLG | Transmit START when bus is free |
| 68h | Arbitration lost, SLA+W received, ACK transmitted ³ | Clear IFLG, clear AAK = 0 | Receive data byte, transmit NACK |
| | | Or clear IFLG, set AAK = 1 | Receive data byte, transmit ACK |
| 78h | Arbitration lost, General call addr received, ACK transmitted | Same as code 68h | Same as code 68h |
| B0h | Arbitration lost, SLA+R received, ACK transmitted | Write byte to DATA, clear IFLG, clear AAK = 0 | Transmit last byte, receive ACK |
| | | Or write byte to DATA, clear IFLG, set AAK = 1 | Transmit data byte, receive ACK |

Notes:

1. AAK is an I²C control bit that identifies which ACK signal to transmit.
2. R is defined as the Read bit; i.e., the lsb is set to 1.
3. W is defined as the Write bit; i.e., the lsb is cleared to 0.



If 10-bit addressing is being used, the slave is first addressed using the full 10-bit address, plus the Write bit. The master then issues a restart followed by the first part of the 10-bit address again, this time with the Read bit. The status code then becomes 40h or 48h. It is the responsibility of the slave to remember that it had been selected prior to the restart.

If a repeated START condition is received, the status code is 10h instead of 08h.

After each data byte is received, the IFLG is set to 1 and one of the status codes listed in Table 122 is loaded into the I2C_SR register.

Table 122. I²C Master Receive Status Codes For Data Bytes

| Code | I ² C State | Microcontroller Response | Next I ² C Action |
|------|--------------------------------------|---|----------------------------------|
| 50h | Data byte received, ACK transmitted | Read data, clear IFLG, clear AAK = 0* | Receive data byte, transmit NACK |
| | | Or read data, clear IFLG, set AAK = 1 | Receive data byte, transmit ACK |
| 58h | Data byte received, NACK transmitted | Read data, set STA, clear IFLG | Transmit repeated START |
| | | Or read data, set STP, clear IFLG | Transmit STOP |
| | | Or read data, set STA & STP, clear IFLG | Transmit STOP then START |
| 38h | Arbitration lost in NACK bit | Same as master transmit | Same as master transmit |

Note: AAK is an I²C control bit that identifies which ACK signal to transmit.

When all bytes are received, a NACK should be sent, then the microcontroller should write a 1 to the STP bit in the I2C_CTL register. The I²C then transmits a STOP condition, clears the STP bit and returns to an idle state.

Slave Transmit

In SLAVE TRANSMIT mode, a number of bytes are transmitted to a master receiver.

The I²C enters SLAVE TRANSMIT mode when it receives its own slave address and a Read bit after a START condition. The I²C then transmits an ACK bit (if the AAK bit is set to 1); it then sets the IFLG bit in the I2C_CTL register. As a result, the I2C_SR register contains the status code A8h.

- **Note:** When I²C contains a 10-bit slave address (signified by the address range F0h–F7h in the I2C_SAR register), it transmits an ACK when the first address byte is received after a restart. An interrupt is generated and IFLG is set to 1; however, the status does not change. No second address byte is sent by the master. It is up to the slave to remember it had been selected prior to the restart.

I²C goes from MASTER mode to SLAVE TRANSMIT mode when arbitration is lost during the transmission of an address, and the slave address and Read bit are received. This action is represented by the status code B0h in the I2C_SR register.

The data byte to be transmitted is loaded into the I2C_DR register and the IFLG bit is cleared to 0. After the I²C transmits the byte and receives an ACK, the IFLG bit is set to 1 and the I2C_SR register contains B8h. When the final byte to be transmitted is loaded into the I2C_DR register, the AAK bit is cleared when the IFLG is cleared to 0. After the final byte is transmitted, the IFLG is set and the I2C_SR register contains C8h and the I²C returns to an idle state. The AAK bit must be set to 1 before reentering SLAVE mode.

If no ACK is received after transmitting a byte, the IFLG is set and the I2C_SR register contains C0h. The I²C then returns to an idle state.

If a STOP condition is detected after an ACK bit, the I²C returns to an idle state.

Slave Receive

In SLAVE RECEIVE mode, a number of data bytes are received from a master transmitter.

The I²C enters SLAVE RECEIVE mode when it receives its own slave address and a Write bit (Isb = 0) after a START condition. The I²C transmits an ACK bit and sets the IFLG bit in the I2C_CTL register and the I2C_SR register contains the status code 60h. The I²C also enters SLAVE RECEIVE mode when it receives the general call address 00h (if the GCE bit in the I2C_SAR register is set). The status code is then 70h.

- **Note:** When the I²C contains a 10-bit slave address (signified by F0h–F7h in the I2C_SAR register), it transmits an acknowledge after the first address byte is received but no interrupt is generated. IFLG is not set and the status does not change. The I²C generates an interrupt only after the second address byte is received. The I²C sets the IFLG bit and loads the status code as described above.

I²C goes from MASTER mode to SLAVE RECEIVE mode when arbitration is lost during the transmission of an address, and the slave address and Write bit (or the general call address if the CGE bit in the I2C_SAR register is set to 1) are received. The status code in the I2C_SR register is 68h if the slave address is

received or 78h if the general call address is received. The IFLG bit must be cleared to 0 to allow data transfer to continue.

If the AAK bit in the **I2C_CTL** register is set to 1 then an ACK bit (Low level on SDA) is transmitted and the IFLG bit is set after each byte is received. The **I2C_SR** register contains the two status codes 80h or 90h if SLAVE RECEIVE mode is entered with the general call address. The received data byte can be read from the **I2C_DR** register and the IFLG bit must be cleared to allow the transfer to continue. If a STOP condition or a repeated START condition is detected after the acknowledge bit, the IFLG bit is set and the **I2C_SR** register contains status code A0h.

If the AAK bit is cleared to 0 during a transfer, the I²C transmits a NACK bit (High level on SDA) after the next byte is received, and sets the IFLG bit to 1. The **I2C_SR** register contains the two status codes 88h or 98h if SLAVE RECEIVE mode is entered with the general call address. The I²C returns to an idle state when the IFLG bit is cleared to 0.

I²C Registers

Addressing

The CPU interface provides access to six 8-bit registers: four Read/Write registers, one Read Only register and two Write Only registers, as indicated in Table 123.

Table 123. I²C Register Descriptions

| Register | Description |
|----------|--------------------------------------|
| I2C_SAR | Slave address register |
| I2C_XSAR | Extended slave address register |
| I2C_DR | Data byte register |
| I2C_CTL | Control register |
| I2C_SR | Status register (Read Only) |
| I2C_CCR | Clock Control register (Write Only) |
| I2C_SRR | Software reset register (Write Only) |

Resetting the I²C Registers

Hardware Reset. When the I²C is reset by a hardware reset of the eZ80F91 device, the **I2C_SAR**, **I2C_XSAR**, **I2C_DR**, and **I2C_CTL** registers are cleared to 00h; while the **I2C_SR** register is set to F8h.



Software Reset. Perform a software reset by writing any value to the I²C Software Reset Register (**I2C_SRR**). A software reset clears the STP, STA, and IFLG bits of the **I2C_CTL** register to 0 and sets the I²C back to an idle state.

I²C Slave Address Register

The **I2C_SAR** register provides the 7-bit address of the I²C when in SLAVE mode and allows 10-bit addressing in conjunction with the **I2C_XSAR** register.

I2C_SAR[7:1] = SLA[6:0] is the 7-bit address of the I²C when in 7-bit SLAVE mode. When the I²C receives this address after a START condition, it enters SLAVE mode. **I2C_SAR[7]** corresponds to the first bit received from the I²C bus.

When the register receives an address starting with **F7h** to **F0h** (**I2C_SAR[7:3] = 11110b**), the I²C recognizes that a 10-bit slave addressing mode is being selected. The I²C sends an ACK after receiving the **I2C_SAR** byte (the device does not generate an interrupt at this point). After the next byte of the address (**I2C_XSAR**) is received, the I²C generates an interrupt and enters SLAVE mode. Then **I2C_SAR[2:1]** are used as the upper 2 bits for the 10-bit extended address. The full 10-bit address is supplied by {**I2C_SAR[2:1], I2C_XSAR[7:0]**}. See Table 124.

Table 124. I²C Slave Address Register
(**I2C_SAR = 00C8h**)

| Bit | 7 | 6 | 5 | 4 | 3 | 2 | 1 | 0 |
|-------------------|-----|-----|-----|-----|-----|-----|-----|-----|
| Reset | 0 | 0 | 0 | 0 | 0 | 0 | 0 | 0 |
| CPU Access | R/W | R/W | R/W | R/W | R/W | R/W | R/W | R/W |

Note: R/W = Read/Write.

| Bit Position | Value | Description |
|--------------|-------------|--|
| [7:1] SLA | 00h– 7Fh | 7-bit slave address or upper 2 bits, I2C_SAR[2:1] , of address when operating in 10-bit mode. |
| 0 GCE | 0 | I ² C not enabled to recognize the General Call Address. |
| | 1 | I ² C enabled to recognize the General Call Address. |

I²C Extended Slave Address Register

The **I2C_XSAR** register is used in conjunction with the **I2C_SAR** register to provide 10-bit addressing of the I²C when in SLAVE mode. The **I2C_SAR** value forms the lower 8 bits of the 10-bit slave address. The full 10-bit address is supplied by {**I2C_SAR[2:1], I2C_XSAR[7:0]**}.

When the register receives an address starting with **F7h** to **F0h** (**I2C_SAR[7:3] = 11110b**), the I²C recognizes that a 10-bit slave addressing mode is being selected.



The I²C sends an ACK after receiving the I2C_XSAR byte (the device does not generate an interrupt at this point). After the next byte of the address (I2C_XSAR) is received, the I²C generates an interrupt and enters SLAVE mode. Then I2C_SAR[2:1] are used as the upper 2 bits for the 10-bit extended address. The full 10-bit address is supplied by {I2C_SAR[2:1], I2C_XSAR[7:0]}. See Table 125.

Table 125. I²C Extended Slave Address Register (I2C_XSAR = 00C9h)

| Bit | 7 | 6 | 5 | 4 | 3 | 2 | 1 | 0 |
|------------|-----|-----|-----|-----|-----|-----|-----|-----|
| Reset | 0 | 0 | 0 | 0 | 0 | 0 | 0 | 0 |
| CPU Access | R/W | R/W | R/W | R/W | R/W | R/W | R/W | R/W |

Note: R/W = Read/Write.

| Bit Position | Value | Description |
|---------------|-------------|--|
| [7:0] SLAX | 00h– FFh | Least-significant 8 bits of the 10-bit extended slave address. |

I²C Data Register

This register contains the data byte/slave address to be transmitted or the data byte just received. In TRANSMIT mode, the most-significant bit of the byte is transmitted first. In RECEIVE mode, the first bit received is placed in the most-significant bit of the register. After each byte is transmitted, the I2C_DR register contains the byte that is present on the bus in case a lost arbitration event occurs. See Table 126.

Table 126. I²C Data Register (I2C_DR = 00CAh)

| Bit | 7 | 6 | 5 | 4 | 3 | 2 | 1 | 0 |
|------------|-----|-----|-----|-----|-----|-----|-----|-----|
| Reset | 0 | 0 | 0 | 0 | 0 | 0 | 0 | 0 |
| CPU Access | R/W | R/W | R/W | R/W | R/W | R/W | R/W | R/W |

Note: R/W = Read/Write.

| Bit Position | Value | Description |
|---------------|-------------|-----------------------------|
| [7:0] DATA | 00h– FFh | I ² C data byte. |

I²C Control Register

The I2C_CTL register is a control register that is used to control the interrupts and the master slave relationships on the I²C bus.

When the Interrupt Enable bit (IEN) is set to 1, the interrupt line goes High when the IFLG is set to 1. When IEN is cleared to 0, the interrupt line always remains Low.

When the Bus Enable bit (ENAB) is set to 0, the I²C bus inputs SCLx and SDAX are ignored and the I²C module does not respond to any address on the bus. When ENAB is set to 1, the I²C responds to calls to its slave address and to the general call address if the GCE bit (I2C_SAR[0]) is set to 1.

When the Master Mode Start bit (STA) is set to 1, the I²C enters MASTER mode and sends a START condition on the bus when the bus is free. If the STA bit is set to 1 when the I²C module is already in MASTER mode and one or more bytes are transmitted, then a repeated START condition is sent. If the STA bit is set to 1 when the I²C block is being accessed in SLAVE mode, the I²C completes the data transfer in SLAVE mode and then enters MASTER mode when the bus is released. The STA bit is automatically cleared after a START condition is set. Writing a 0 to the STA bit produces no effect.

If the Master Mode Stop bit (STP) is set to 1 in MASTER mode, a STOP condition is transmitted on the I²C bus. If the STP bit is set to 1 in slave mode, the I²C module operates as if a STOP condition is received, but no STOP condition is transmitted. If both STA and STP bits are set, the I²C block first transmits the STOP condition (if in MASTER mode), then transmits the START condition. The STP bit is cleared to 0 automatically. Writing a 0 to this bit produces no effect.

The I²C Interrupt Flag (IFLG) is set to 1 automatically when any of 30 of the possible 31 I²C states is entered. The only state that does not set the IFLG bit is state F8h. If IFLG is set to 1 and the IEN bit is also set, an interrupt is generated. When IFLG is set by the I²C, the Low period of the I²C bus clock line is stretched and the data transfer is suspended. When a 0 is written to IFLG, the interrupt is cleared and the I²C clock line is released.

When the I²C Acknowledge bit (AAK) is set to 1, an acknowledge is sent during the acknowledge clock pulse on the I²C bus if:

- Either the whole of a 7-bit slave address or the first or second byte of a 10-bit slave address is received
- The general call address is received and the General Call Enable bit in I2C_SAR is set to 1
- A data byte is received while in MASTER or SLAVE modes



When AAK is cleared to 0, a NACK is sent when a data byte is received in MASTER or SLAVE mode. If AAK is cleared to 0 in SLAVE TRANSMIT mode, the byte in the I2C_DR register is assumed to be the final byte. After this byte is transmitted, the I²C block enters the c8h state, then returns to an idle state. The I²C module does not respond to its slave address unless AAK is set to 1. See Table 127.

**Table 127. I²C Control Register
(I2C_CTL = 00CBh)**

| Bit | 7 | 6 | 5 | 4 | 3 | 2 | 1 | 0 |
|------------|-----|-----|-----|-----|-----|-----|---|---|
| Reset | 0 | 0 | 0 | 0 | 0 | 0 | 0 | 0 |
| CPU Access | R/W | R/W | R/W | R/W | R/W | R/W | R | R |

Note: R/W = Read/Write; R = Read Only.

| Bit Position | Value | Description |
|--------------|-------|--|
| 7 IEN | 0 | I ² C interrupt is disabled. |
| | 1 | I ² C interrupt is enabled. |
| 6 ENAB | 0 | The I ² C bus (SCL/SDA) is disabled and all inputs are ignored. |
| | 1 | The I ² C bus (SCL/SDA) is enabled. |
| 5 STA | 0 | Master mode START condition is sent. |
| | 1 | Master mode start-transmit START condition on the bus. |
| 4 STP | 0 | Master mode STOP condition is sent. |
| | 1 | Master mode stop-transmit STOP condition on the bus. |
| 3 IFLG | 0 | I ² C interrupt flag is not set. |
| | 1 | I ² C interrupt flag is set. |
| 2 AAK | 0 | Not Acknowledge. |
| | 1 | Acknowledge. |
| [1:0] | 00 | Reserved. |



I²C Status Register

The I2C_SR register is a Read Only register that contains a 5-bit status code in the five most-significant bits; the three least-significant bits are always 0. The Read Only I2C_SR registers share the same I/O addresses as the Write Only I2C_CCR registers. See Table 128.

**Table 128. I²C Status Registers
(I2C_SR = 00CCh)**

| Bit | 7 | 6 | 5 | 4 | 3 | 2 | 1 | 0 |
|-------------------|---|---|---|---|---|---|---|---|
| Reset | 1 | 1 | 1 | 1 | 1 | 0 | 0 | 0 |
| CPU Access | R | R | R | R | R | R | R | R |

Note: R = Read only.

| Bit Position | Value | Description |
|---------------|-----------------|-------------------------------------|
| [7:3] STAT | 00000– 11111 | 5-bit I ² C status code. |
| [2:0] | 000 | Reserved. |

There are 29 possible status codes, as listed in Table 129. When the I2C_SR register contains the status code F8h, no relevant status information is available, no interrupt is generated, and the IFLG bit in the I2C_CTL register is not set. All other status codes correspond to a defined state of the I²C.

When each of these states is entered, the corresponding status code appears in this register and the IFLG bit in the I2C_CTL register is set to 1. When the IFLG bit is cleared, the status code returns to F8h.

Table 129. I²C Status Codes

| Code | Status |
|------|---|
| 00h | Bus error. |
| 08h | START condition transmitted. |
| 10h | Repeated START condition transmitted. |
| 18h | Address and Write bit transmitted, ACK received. |
| 20h | Address and Write bit transmitted, ACK not received. |
| 28h | Data byte transmitted in MASTER mode, ACK received. |
| 30h | Data byte transmitted in MASTER mode, ACK not received. |

Table 129. I²C Status Codes (Continued)

| Code | Status |
|------|---|
| 38h | Arbitration lost in address or data byte. |
| 40h | Address and Read bit transmitted, ACK received. |
| 48h | Address and Read bit transmitted, ACK not received. |
| 50h | Data byte received in MASTER mode, ACK transmitted. |
| 58h | Data byte received in MASTER mode, NACK transmitted. |
| 60h | Slave address and Write bit received, ACK transmitted. |
| 68h | Arbitration lost in address as master, slave address and Write bit received, ACK transmitted. |
| 70h | General Call address received, ACK transmitted. |
| 78h | Arbitration lost in address as master, General Call address received, ACK transmitted. |
| 80h | Data byte received after slave address received, ACK transmitted. |
| 88h | Data byte received after slave address received, NACK transmitted. |
| 90h | Data byte received after General Call received, ACK transmitted. |
| 98h | Data byte received after General Call received, NACK transmitted. |
| A0h | STOP or repeated START condition received in SLAVE mode. |
| A8h | Slave address and Read bit received, ACK transmitted. |
| B0h | Arbitration lost in address as master, slave address and Read bit received, ACK transmitted. |
| B8h | Data byte transmitted in SLAVE mode, ACK received. |
| C0h | Data byte transmitted in SLAVE mode, ACK not received. |
| C8h | Last byte transmitted in SLAVE mode, ACK received. |
| D0h | Second Address byte and Write bit transmitted, ACK received. |
| D8h | Second Address byte and Write bit transmitted, ACK not received. |
| F8h | No relevant status information, IFLG = 0. |

If an illegal condition occurs on the I²C bus, the bus error state is entered (status code 00h). To recover from this state, the STP bit in the I2C_CTL register must be set and the IFLG bit cleared. The I²C then returns to an idle state. No STOP condition is transmitted on the I²C bus.

► **Note:** The STP and STA bits can be set to 1 at the same time to recover from the bus error. The I²C then sends a START condition.

I²C Clock Control Register

The I2C_CCR register is a Write Only register. The seven LSBs control the frequency at which the I²C bus is sampled and the frequency of the I²C clock line (SCL) when the I²C is in MASTER mode. The Write Only I2C_CCR registers share the same I/O addresses as the Read Only I2C_SR registers. See Table 130.

Table 130. I²C Clock Control Registers (I2C_CCR = 00CCh)

| Bit | 7 | 6 | 5 | 4 | 3 | 2 | 1 | 0 |
|-------------------|---|---|---|---|---|---|---|---|
| Reset | 0 | 0 | 0 | 0 | 0 | 0 | 0 | 0 |
| CPU Access | W | W | W | W | W | W | W | W |

Note: W = Read only.

| Bit Position | Value | Description |
|--------------|---------------|--|
| 7 | 0 | Reserved. |
| [6:3] M | 0000– 1111 | I ² C clock divider scalar value. |
| [2:0] N | 000– 111 | I ² C clock divider exponent. |

The I²C clocks are derived from the system clock of the eZ80F91 device. The frequency of this system clock is f_{SCLK} . The I²C bus is sampled by the I²C block at the frequency f_{SAMP} supplied by the following equation:

$$f_{SAMP} = \frac{f_{SCLK}}{2^N}$$

In MASTER mode, the I²C clock output frequency on SCL (f_{SCL}) is supplied by the following equation:

$$f_{SCL} = \frac{f_{SCLK}}{10 \cdot (M + 1)(2)^N}$$

The use of two separately-programmable dividers allows the MASTER mode output frequency to be set independently of the frequency at which the I²C bus is sampled. This feature is particularly useful in multimaster systems because the



frequency at which the I²C bus is sampled must be at least 10 times the frequency of the fastest master on the bus to ensure that START and STOP conditions are always detected. By using two programmable clock divider stages, a high sampling frequency can be ensured while allowing the MASTER mode output to be set to a lower frequency.

Bus Clock Speed

The I²C bus is defined for bus clock speeds up to 100kbps (400kbps in FAST mode).

To ensure correct detection of START and STOP conditions on the bus, the I²C must sample the I²C bus at least ten times faster than the bus clock speed of the fastest master on the bus. The sampling frequency should therefore be at least 1MHz (4MHz in FAST mode) to guarantee correct operation with other bus masters.

The I²C sampling frequency is determined by the frequency of the eZ80F91 system clock and the value in the I2C_CCR bits 2 to 0. The bus clock speed generated by the I²C in MASTER mode is determined by the frequency of the input clock and the values in I2C_CCR[2:0] and I2C_CCR[6:3].

I²C Software Reset Register

The I2C_SRR register is a Write Only register. Writing any value to this register performs a software reset of the I²C module. See Table 131.

Table 131. I²C Software Reset Register (I2C_SRR = 00CDh)

| Bit | 7 | 6 | 5 | 4 | 3 | 2 | 1 | 0 |
|------------|---|---|---|---|---|---|---|---|
| Reset | X | X | X | X | X | X | X | X |
| CPU Access | W | W | W | W | W | W | W | W |

Note: W = Write Only.

| Bit Position | Value | Description |
|--------------|-------------|--|
| [7:0] SRR | 00h– FFh | Writing any value to this register performs a software reset of the I ² C module. |

Ethernet Media Access Controller

The Ethernet Media Access Controller (EMAC) is a full-function 10/100 Mbps media access control module with a Media-Independent Interface (MII). This EMAC and interface combination is called a EMACMII module. Figure 47 presents an illustration of the EMAC block.

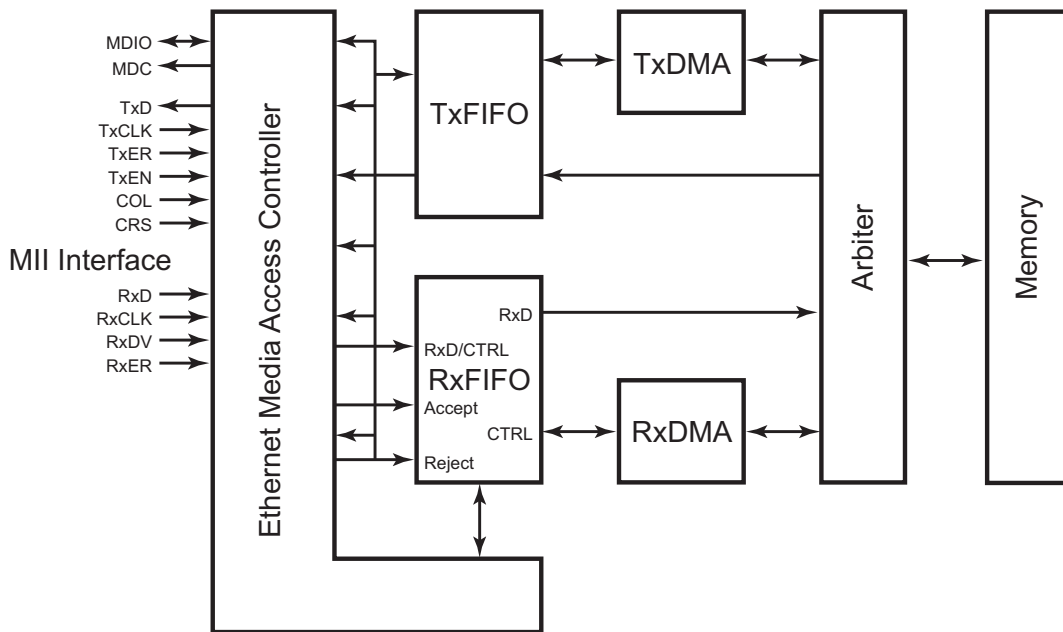

Figure 47. EMAC Block Diagram

The EMACMII module consists of six submodules that represent the Transmit and Receive portions of the Ethernet MAC, plus the EMAC sublayer module. In addition, there is a host interface module, a central clock and reset module, and an MII management module. There are many different applications possible, including network interface designs, Ethernet switching designs, and test equipment designs.

The EMAC functions are contained in the Transmit and Receive modules. These modules represent the core MAC. 802.3x flow control implemented by the EMAC sublayer module.

The MII management module provides a two-wire control/status path to the MII PHY. Read and Write communication to and from registers within the PHY is accomplished via the host interface.

- **Note:** MII PHY is a Physical Layer transceiver device; PHY does not refer to the eZ80F91 system clock output pin, PHI.

The MII management module provides a two-wire control/status path to the MII. Read and Write communication to and from registers within the PHY is accomplished via the host interface.

www.DataSheet4U.com

EMAC Functional Description

The EMAC block implements memory, arbiter, and transmit and receive direct memory access functions, as described in this section.

Memory

EMAC memory is the shared Ethernet memory location of the Transmit and Receive buffers. This memory is broken into two parts: the Tx buffer and the Rx buffer. The Transmit Lower Boundary Pointer Register, EmacTLBP, is the register that holds the starting address of the Tx buffer. The Boundary Pointer Register, EmacBP, points to the start of the Rx buffer (end of Tx buffer + 1). The Receive High Boundary Pointer Register, EmacRHBP, points to the end of the Rx buffer + 1. The Tx and Receive buffers are divided into packet buffers of either 256, 128, 64, or 32 bytes. These buffer sizes are selected by EmacBufSize register bits 7 and 6.

The EmacBlksLeft register contains the number of Receive packet buffers remaining in the Rx buffer. This buffer can be used for software flow control. If the Block_Level is nonzero (bits 5:0 of the EmacBufSize register), hardware flow control is enabled. If in Full Duplex Mode, the EMAC transmits a pause control frame when the EmacBlksLeft register is less than the Block_Level. In Half Duplex mode, the EMAC continually transmits a nibble pattern of hexadecimal 5's to jam the channel.

Four pointers are defined for reading and writing the Tx and Rx buffers. The Transmit Write Pointer, TWP, is a software pointer that points to the next available packet buffer. The TWP is reset to the value stored in EmacTLBP. The Transmit Read Pointer, TRP, is a hardware pointer in the Transmit Direct Memory Access Register, TxDMA, that contains the address of the next packet to be transmitted. It is automatically reset to the EmacTLBP. The Receive Write Pointer, RWP, is a hardware pointer in the Receive Direct Memory Access Register, RxDMA, which contains the storage address of the incoming packet. The RWP pointer is automatically initialized to the Boundary Pointer registers. The Receive Read Pointer, RRP, is a software pointer to where the next packet should be read from. The RRP pointer should be initialized to the Boundary Pointer registers. For the hardware flow control to function properly, the software must update the hardware RRP (EmacRrp) pointer whenever the software version is updated. The RxDMA



uses RWP and the RRP to determine how many packet buffers remain in the Rx buffer.

Arbiter

The arbiter controls access to EMAC memory. It prioritizes the requests for memory access between the CPU, the TxDMA, and the RxDMA. The TxDMA offers two levels of priority: a high priority when the TxFIFO is less than half full and a Low priority when the TxFIFO is more than half full. Similarly, the RxDMA offers two levels of priority: a high priority when the RxFIFO is more than half full and a Low priority when the RxFIFO is less than half full.

The arbiter determines resolution between the CPU, the RxDMA, and the TxDMA requests to access EMAC memory. Post writing for CPU Writes results in zero-wait-state write access timing when the CPU assumes the highest priority. CPU Reads require a minimum of 1 wait state and can take more when the CPU does not hold the highest priority. The CPU Read wait state is not a user-controllable operation, because it is controlled by the arbiter. The RxDMA and TxDMA requests are not allowed to occur back-to-back. Therefore, the maximum throughput rate for the two Direct Memory Access (DMA) ports is 25 megabytes per second each (one byte every 2 clocks) when the system clock is running at 50MHz. The rate is reduced to 20 megabytes per second for a 40MHz system clock. The arbiter uses the internal WAIT signal to add wait states to CPU access when required. See Table 132.

Table 132. Arbiter Priority

| Priority Level | Device Serviced | Flags |
|----------------|-----------------------|--------------------------|
| 0 | RxDMA High | RxFIFO > half full (FAF) |
| 1 | TxDMA High | TxFIFO < half full (FAE) |
| 2 | eZ80 [®] CPU | |
| 3 | RxDMA Low | RxFIFO < half full (FAE) |
| 4 | TxDMA Low | TxFIFO > half full (FAF) |

TxDMA

The TxDMA module moves the next packet to be transmitted from EMAC memory into the TxFIFO. Whenever the polling timer expires, the TxDMA reads the High status byte from the Tx descriptor table pointed to by the Transmit Read Pointer, TRP. Polling continues until the High status Read reaches bit 7, when the Emac_Owns ownership semaphore, bit 15 of the descriptor table (see Table 134) is set to 1. The TxDMA then initializes the packet length counter with the size of

the packet from descriptor table bytes 3 and 4. The TxDMA moves the data into the TxFIFO until the packet length counter downcounts to zero. The TxDMA then waits for Transmission Complete signal to be asserted to indicate that the packet is sent and that the Transmit status from the EMAC is valid. The TxDMA updates the descriptor table status and resets the ownership semaphore, bit 15. Finally, the Tx_DONE_STAT bit of the [EMAC Interrupt Status Register](#) is set to 1, the address field, DMA_Address, is updated from the descriptor table next pointer, NP (see [Figure 50](#)). The High byte of the status is read to determine if the next packet is ready to be transmitted.

While the TxDMA is filling the TxFIFO, it monitors two signals from the Transmit FIFO State Machine (TxFifoSM) to detect error conditions and to determine if the packet is to be retransmitted (TxDMA_Retry asserted) or the packet is aborted (TxDMA_Abort asserted). If the packet is aborted, the TxDMA updates the descriptor status and moves to the next packet. If the packet is to be retried, the DMA_Address is reset to the start of the packet, the packet length counter is reloaded from the descriptor table, bytes 3 and 4, and the packet is moved into the TxFIFO again. When an abort or retry event occurs, the TxDMA asserts the appropriate signal to reset the TxFIFO Read and Write pointers which clears out any data that is in the FIFO. The TxFifoSM negates the TxDMA_Abort and/or TxDMA_Retry signal(s) when the TxFCWP signal is High. This handshaking maintains synchronization between the TxDMA and the TxFifoSM.

RxDMA

The RxDMA reads the data from the Rx FIFO and stores it in the EMAC memory Receive buffer. When the end of the packet is detected, the RxDMA reads the next two bytes from the Rx FIFO and writes them into the Rx descriptor status LSB and MSB. The packet length counter is stored into the descriptor table packet length field, the descriptor table next pointer is written into the Rx descriptor table and finally the Rx_DONE_STAT bit in the EMAC Interrupt Status Register register is set to 1.

EMAC Interrupts

Eight different sources of interrupts from the EMAC are described in Table 133.

Table 133. EMAC Interrupts

| Interrupt | Description |
|------------------------------------|--|
| EMAC System Interrupts | |
| Transmit State Machine Error | Bit 7 (TxFSMERR_STAT) of the EMAC Interrupt Status Register (EMAC_ISTAT). A Transmit State Machine Error should never occur. However, if this bit is set, the entire transmitter module must be reset. |
| MIIMGT Done | Bit 6 (MGTDONE_STAT) of the Interrupt Status Register (EMAC_ISTAT). This bit is set when communicating to the PHY over the MII during a Read or Write operation. |
| Receive Overrun | Bit 2 (Rx_OVR_STAT) of the Interrupt Status Register (EMAC_ISTAT). If this bit is set, all incoming packets are ignored until this bit is cleared by software. |
| EMAC Transmitter Interrupts | |
| Transmit Control Frame | Transmit Control Frame = Bit 1 (Tx_CF_STAT) of the Interrupt Status Register (EMAC_ISTAT). Denotes when control frame transmission is complete. |
| Transmit Done | Bit 0 (Tx_DONE_STAT) of the Interrupt Status Register (EMAC_ISTAT). Denotes when packet transmission is complete. |
| EMAC Receiver Interrupts | |
| Receive Control Frame | Bit 5 (Rx_CF_STAT) of the Interrupt Status Register (EMAC_ISTAT). Denotes when control frame reception is complete. |
| Receive Pause Control Frame | Bit 4 (Rx_PCF_STAT) of the Interrupt Status Register (EMAC_ISTAT). Denotes when pause control frame reception is complete. |
| Receive Done | Bit 3 (Rx_DONE_STAT) of the Interrupt Status Register (EMAC_ISTAT). Denotes when control frame reception is complete. |

EMAC Shared Memory Organization

Internal Ethernet SRAM shares memory with the CPU. This memory is divided into the Transmit buffer and the Receive buffer by defining three registers, as listed below.

- Transmit Lower Boundary Pointer (TLBP)—this register points to the start of the Transmit buffer in the internal Ethernet shared memory space
- Boundary Pointer (BP)—this register points to the start of the Receive buffer
- Receive High Boundary Pointer (RHBP)—this register points to the end of the Receive buffer + 1

This internal Ethernet shared memory is depicted in Figure 48.

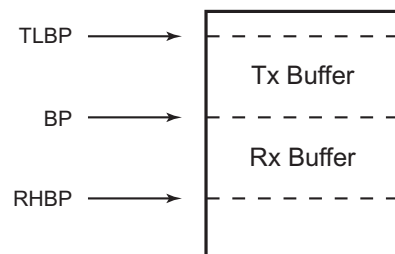

Figure 48. internal Ethernet Shared Memory

The Transmit and Receive buffers are able to be subdivided into packet buffers of 32, 64, 128, or 256 bytes in size. The packet buffer size is set in bits 7 and 6 of the EmacBufSize register. An Ethernet packet can accommodate multiple packet buffers. At the start of each packet is a descriptor table that describes the packet. Each actual Ethernet packet follows the descriptor table, as illustrated in Figure 49.

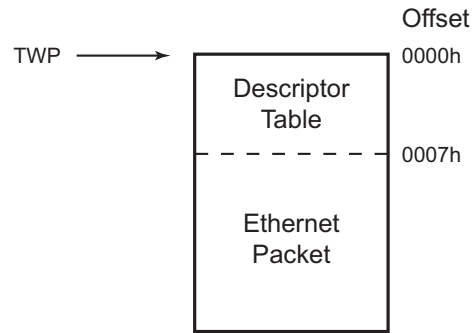

Figure 49. Descriptor Table

The descriptor table contains three entries: the next pointer (NP), the packet size (Pkt_Size) and the packet status (Stat), as illustrated in Figure 50.

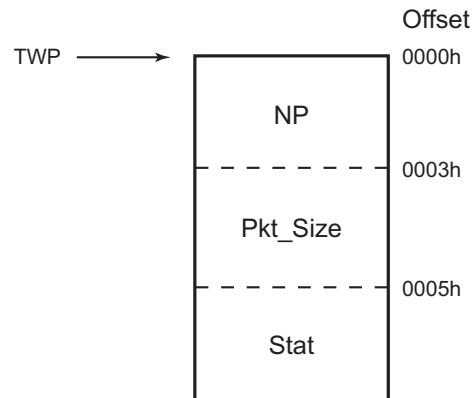

Figure 50. Descriptor Table Entries

NP is a 24-bit pointer to the start of the next packet. Pkt_Size contains the number of bytes of data in the Ethernet packet, including the four CRC bytes, but does not contain the seven descriptor table bytes. Stat contains the status of the packet. Stat differs for Transmit and Receive packets. See Tables 134 and 135.

Table 134. Transmit Descriptor Status

| Bit | Name | Description |
|-----|---------|--|
| 15 | TxOwner | 0 = Host (eZ80 [®]) owns, 1 = EMAC owns. |
| 14 | TxAbort | 1 = Packet aborted (not transmitted). |
| 13 | TxBPA | 1 = Back pressure applied. |

Table 134. Transmit Descriptor Status

| Bit | Name | Description |
|-------|----------------------|---|
| 12 | TxHuge | 1 = Packet size is very large (Pkt_Size > EmacMaxf). |
| 11 | TxLOOR | 1 = Type/Length field is out of range (larger than 1518 bytes). |
| 10 | TxLCError | 1 = Type/Length field is not a Type field and it does not match the actual data byte length of the Ethernet packet. The data byte length is the number of bytes of data in the Ethernet packet between the Type/Length field and the FCS. |
| 9 | TxCrcError | 1 = The packet contains an invalid FCS (CRC). This flag is set when CRCEN = 0 and the last 4 bytes of the packet are not the valid FCS. |
| 8 | TxPktDeferred | 1 = Packet is deferred. |
| 7 | TxXsDfr | 1 = Packet is excessively deferred. (> 6071 nibble times in 100BaseT or 24,287 bit times in 10BaseT). |
| 6 | TxFifoUnderRun | 1 = TxFIFO experiences Underrun. Check the TxAbort bit to see if the packet is aborted or retried. |
| 5 | TxLateCol | 1 = A late collision occurs. Collision is detected at a byte count > EmacCfg2[5:0]. Collisions detected before the byte count reaches EmacCfg2[5:0] are early collisions and retried. |
| 4 | TxMaxCol | 1 = The maximum number of collisions occurs. #Collisions > EmacCfg3[3:0]. These packets are aborted. |
| [3:0] | TxNumberOfCollisions | This field contains the number of collisions that occur while transmitting the packet. |

Table 135. Receive Descriptor Status

| Bit | Name | Description |
|-----|--------------|---|
| 15 | RxOK | 1 = Packet received intact. |
| 14 | RxAlignError | 1 = An odd number of nibbles is received. |
| 13 | RxCrcError | 1 = The CRC (FCS) is in error. |
| 12 | RxLongEvent | 1 = A Long or Dropped Event occurs. A Long Event is when a packet over 50,000 bit times occurs. A Dropped Packet can occur if the minimum interpacket gap is not met, the preamble is not pure, and the EmacCfg3[PUREP] bit is set, or if a preamble over 11 bytes in length is detected and the EmacCfg3[LONGP] bit is set to 1. |
| 11 | RxPCF | 1 = The packet is a pause control frame. |
| 10 | RxCF | 1 = The packet is a control frame. |

Table 135. Receive Descriptor Status (Continued)

| Bit | Name | Description |
|-----|-----------|---|
| 9 | RxMcPkt | 1 = The packet contains a multicast address. |
| 8 | RxBcPkt | 1 = The packet contains a broadcast address. |
| 7 | RxVLAN | 1 = The packet is a VLAN packet. |
| 6 | RxUOpCode | 1 = An unsupported Op Code is indicated in the Op Code field of the Ethernet packet. |
| 5 | RxLOOR | 1 = The Type/Length field is out of range (larger than 1518 bytes). |
| 4 | RxLCError | 1 = Type/Length field is not a Type field and it does not match the actual data byte length of the Ethernet packet. The data byte length is the number of bytes of data in the Ethernet packet between the Type/Length field and the FCS. |
| 3 | RxCodv | 1 = A code violation is detected. The PHY asserts Rx error (RxER). |
| 2 | RxCEvent | 1 = A carrier event is previously seen. This event is defined as Rx error RxER = 1, receive data valid (RxDV) = 0 and receive data (RxD) = Eh. |
| 1 | RxDvEvent | 1 = A receive data (RxDV) event is previously seen. Indicates that the last Receive event is not long enough to be a valid packet. |
| 0 | RxOVR | 1 = A Receive Overrun occurs in this packet. An overrun occurs when all of the EMAC Receive buffers are in use and the Receive FIFO is full. The hardware ignores all incoming packets until the EmacIStat Register [Rx_Ovr] bit is cleared by the software. There is no indication as to how many packets are ignored. |

EMAC and the System Clock

Effective Ethernet throughput in any given system is dependent upon factors such as system clock speed, network protocol overhead, application complexity, and network traffic conditions at any given moment. The following information provides a general guideline about the effects of system clock speed on Ethernet operation.

The eZ80F91 MCU's EMAC block performs a synchronous function that is designed to operate over a wide range of system clock frequencies. To understand its maximum data transfer capabilities at certain system operating frequencies, the user must first understand the internal data bus bandwidth that is required under ideal conditions.

For 10BaseT Ethernet connectivity, the data rate is 10Mbits per second, which equates to 1.25Mbytes per second. If the eZ80F91 MCU is operating in full duplex mode over 10BaseT, the data rate for RX data and TX data is 1.25Mbytes per

second. Because raw data transfers at this rate consume a certain amount of CPU bandwidth, the CPU must support traffic from both directions as well as operate at a minimum clock frequency of $(1.25 + 1.25) * 2 = 5\text{Mhz}$ while transferring Ethernet packets to and from the physical layer.

Similarly, for 100BaseT Ethernet, the data rate is 100Mbits per second, which equates to 12.5Mbytes per second. If the eZ80F91 MCU is operating in full duplex mode over 100BaseT, the data rate for RX data and TX data is 12.5Mbytes per second. Because raw data transfers at this rate consume a certain amount of CPU bandwidth, the CPU must support traffic from both directions as well as operate at a minimum clock frequency of $(12.5 + 12.5) * 2 = 50\text{Mhz}$ while transferring Ethernet packets to and from the physical layer. Consequently, 50MHz is the minimum system clock speed that the eZ80[®] CPU requires to sustain EMAC data transfers while not also including any software overhead or additional eZ80[®] tasks.

The FIFO functionality of the EMAC operates at any frequency as long as the user application avoids overrun and underrun errors via higher-level flow control. Actual application requirements will dictate Ethernet modes of operation (full-duplex, half-duplex, etc.). Because each user and application is different, it becomes the user's responsibility to control the data flow with these parameters. Under ideal conditions, the system clock will operate somewhere between 5MHz and 50MHz to handle the EMAC data rates.

EMAC Operation in HALT Modes

When the CPU is in HALT mode, the eZ80F91 device's EMAC block cannot be disabled as can other peripherals. Upon receipt of an Ethernet packet, a maskable Receive interrupt is generated by the EMAC block, just as it would be in a non-halt mode. Accordingly, the processor wakes up and continues with the user-defined application.

EMAC Registers

After a system reset, all EMAC registers are set to their default values. Any Writes to unused registers or register bits are ignored and reads return a value of 0. For compatibility with future revisions, unused bits within a register should always be written with a value of 0. Read/Write attributes, reset conditions, and bit descriptions of all of the EMAC registers are provided in this section.

EMAC Test Register

The EMAC Test Register allows test functionality of the EMAC module. Available test modes are defined for bits [6:0]. See Table 136.



**Table 136. EMAC Test Register
(EMAC_TEST = 0020h)**

| Bit | 7 | 6 | 5 | 4 | 3 | 2 | 1 | 0 |
|-------------------|---|-----|-----|-----|-----|-----|-----|-----|
| Reset | 0 | 0 | 0 | 0 | 0 | 0 | 0 | 0 |
| CPU Access | R | R/W | R/W | R/W | R/W | R/W | R/W | R/W |

Note: R/W = Read/Write, R = Read Only.

| Bit Position | Value | Description |
|------------------|-------|--|
| 7 | 0 | Reserved. |
| 6 TEST_FIFO | 0 | FIFO test mode disabled—normal operation. |
| | 1 | FIFO test mode enabled. |
| 5 TxRx_SEL | 0 | Select the Receive FIFO when FIFO test mode is enabled. |
| | 1 | Select the Transmit FIFO when FIFO test mode is enabled. |
| 4 SSTC | 0 | Normal operation. |
| | 1 | Short Cut Slot Timer Counter. Slot time is shortened to speed up simulation. |
| 3 SIMR | 0 | Normal operation. |
| | 1 | Simulation Reset. |
| 2 FRC_OVR_ERR | 0 | Normal operation. |
| | 1 | Force Overrun error in Receive FIFO. |
| 1 FRC_UND_ERR | 0 | Normal operation. |
| | 1 | Force Underrun error in Transmit FIFO. |
| 0 LPBK | 0 | Normal operation. |
| | 1 | EMAC Transmit interface is looped back into EMAC Receive interface. |



EMAC Configuration Register 1

The EMAC Configuration Register 1 allows control of the padding, autodetection, cyclic redundancy checking (CRC) control, full duplex, field length checking, maximum packet ignores, and proprietary header options. See Table 137.

**Table 137. EMAC Configuration Register 1
(EMAC_CFG1 = 0021h)**

| Bit | 7 | 6 | 5 | 4 | 3 | 2 | 1 | 0 |
|-------------------|-----|-----|-----|-----|-----|-----|-----|-----|
| Reset | 0 | 0 | 0 | 0 | 0 | 0 | 0 | 0 |
| CPU Access | R/W | R/W | R/W | R/W | R/W | R/W | R/W | R/W |

Note: R/W = Read/Write.

| Bit Position | Value | Description |
|--------------|-------|---|
| 7 PADEN | 0 | No padding. Assume all frames presented to EMAC have proper length. |
| | 1 | EMAC pads all short frames by adding zeroes to the end of the data field. This bit is used in conjunction with ADPADN and VLPAD. |
| 6 ADPADN | 0 | Disable autodetection. |
| | 1 | Enable frame detection by comparing the two octets following the source address with 0x8100 (VLAN Protocol ID) and pad accordingly. This bit is ignored if PADEN is cleared to 0. |
| 5 VLPAD | 0 | Do not pad all short frames. |
| | 1 | EMAC pads all short frames to 64 bytes and append a valid CRC. This bit is ignored if PADEN is cleared to 0. |
| 4 CRCEN | 0 | Do not append CRC. |
| | 1 | Append CRC to every frame regardless of padding options. |
| 3 FULLD | 0 | Half-duplex mode. CSMA/CD is enabled. |
| | 1 | Enable full duplex mode. CSMA/CD is disabled. |
| 2 FLCHK | 0 | Ignore the length field within Transmit/Receive frames. |
| | 1 | Both Transmit and Receive frame lengths are compared to the length/type field. If the length/type field represents a length then the frame length check is performed. |
| 1 HUGEN | 0 | Limit the Receive frame-size to the number of bytes specified in the MAXF[15:0] field. |
| | 1 | Allow unlimited sized frames to be received. Ignore the MAXF[15:0] field. |



| Bit Position | Value | Description |
|--------------|-------|---|
| DCRCC | 0 | No proprietary header. Normal operation. |
| | 1 | Four bytes of proprietary header (ignored by CRC) exists on the front of IEEE 802.3 frames. |

www.DataSheet4U.com

Table 138 shows the results of different settings for bits [7:4] of EMAC Configuration Register 1.

Table 138. CRC/PAD Features of EMAC Configuration Register

| ADPADN | VLPADN | PADEN | CRCEN | Result |
|--------|--------|-------|-------|--|
| 0 | 0 | 0 | 0 | No pad or CRC appended. |
| 0 | 0 | 0 | 1 | CRC appended. |
| 0 | 0 | 1 | 0 | Pad to 60 bytes if necessary; append CRC (min. size = 64). |
| 0 | 0 | 1 | 1 | Pad to 60 bytes if necessary; append CRC (min. size = 64). |
| 0 | 1 | 0 | 0 | No pad or CRC appended. |
| 0 | 1 | 0 | 1 | CRC appended. |
| 0 | 1 | 1 | 0 | Pad to 64 bytes if necessary, append CRC (min. size = 68). |
| 0 | 1 | 1 | 1 | Pad to 64 bytes if necessary, append CRC (min. size = 68). |
| 1 | 0 | 0 | 0 | No pad or CRC appended. |
| 1 | 0 | 0 | 1 | CRC appended. |
| 1 | 0 | 1 | 0 | If VLAN not detected, pad to 60, add CRC. If VLAN detected, pad to 64, add CRC. |
| 1 | 0 | 1 | 1 | If VLAN not detected, pad to 60, add CRC. If VLAN detected, pad to 64, add CRC. |
| 1 | 1 | 0 | 0 | No pad or CRC appended. |
| 1 | 1 | 0 | 1 | CRC appended. |
| 1 | 1 | 1 | 0 | If VLAN not detected, pad to 60, add CRC. If VLAN detected, pad to 64, add CRC. |
| 1 | 1 | 1 | 1 | If VLAN not detected, pad to 60, add CRC. If VLAN detected, pad to 64, add CRC. |



EMAC Configuration Register 2

The EMAC Configuration Register 2 controls the behavior of the back pressure and late collision data from the Descriptor table. See Table 139.

**Table 139. EMAC Configuration Register 2
(EMAC_CFG2 = 0022h)**

| Bit | 7 | 6 | 5 | 4 | 3 | 2 | 1 | 0 |
|-------------------|-----|-----|-----|-----|-----|-----|-----|-----|
| Reset | 0 | 0 | 1 | 1 | 0 | 1 | 1 | 1 |
| CPU Access | R/W | R/W | R/W | R/W | R/W | R/W | R/W | R/W |

Note: R/W = Read/Write.

| Bit Position | Value | Description |
|---------------|-------------|---|
| 7 BPNB | 0 | Use normal back-off algorithm prior to transmitting packet. No back pressure applied. |
| | 1 | After incidentally causing a collision during back pressure, the EMAC immediately (i.e., no back-off) retransmits the packet without back-off, which reduces the chance of further collisions and ensures that the Transmit packets are sent. |
| 6 NOBO | 0 | Enable exponential back-off. |
| | 1 | The EMAC immediately retransmits following a collision rather than use the binary exponential backfill algorithm, as specified in the IEEE 802.3 specification. |
| [5:0] LCOL | 00h– 3Fh | Sets the number of bytes after Start Frame Delimiter (SFD) for which a late collision can occur. By default, all late collisions are aborted. |



EMAC Configuration Register 3

The EMAC Configuration Register 3 controls preamble length and value, excessive deferral, and the number of retransmission tries. See Table 140.

**Table 140. EMAC Configuration Register 3
(EMAC_CFG3 = 0023h)**

| Bit | 7 | 6 | 5 | 4 | 3 | 2 | 1 | 0 |
|-------------------|-----|-----|-----|-----|-----|-----|-----|-----|
| Reset | 0 | 0 | 0 | 0 | 1 | 1 | 1 | 1 |
| CPU Access | R/W | R/W | R/W | R/W | R/W | R/W | R/W | R/W |

Note: R/W = Read/Write.

| Bit Position | Value | Description |
|----------------|-------|--|
| 7 LONGP | 0 | The EMAC allows any preamble length as per the IEEE 802.3 specification. |
| | 1 | The EMAC only allows Receive packets that contain preamble fields less than 12 bytes in length. |
| 6 PUREP | 0 | No preamble error checking is performed. |
| | 1 | The EMAC verifies the content of the preamble to ensure that it contains a value of 55h and that it is error-free. Packets containing an errored preamble are discarded. |
| 5 XSDFR | 0 | The EMAC aborts when the excessive deferral limit is reached. |
| | 1 | The EMAC defers to the carrier indefinitely as per the IEEE 802.3 specification. |
| 4 BITMD | 0 | Disable 10Mbps ENDEC mode. |
| | 1 | Enable 10Mbps ENDEC mode. |
| [3:0] RETRY | 0h–Fh | A programmable field specifying the number of retransmission attempts following a collision before aborting the packet due to excessive collisions. |



EMAC Configuration Register 4

The EMAC Configuration Register 4 controls pause control frame behavior, back pressure, and receive frame acceptance. See Table 141.

**Table 141. EMAC Configuration Register 4
(EMAC_CFG4 = 0024h)**

| Bit | 7 | 6 | 5 | 4 | 3 | 2 | 1 | 0 |
|-------------------|---|-----|-----|-----|-----|-----|-----|-----|
| Reset | 0 | 0 | 0 | 0 | 0 | 0 | 0 | 0 |
| CPU Access | R | R/W | R/W | R/W | R/W | R/W | R/W | R/W |

Note: R = Read Only; R/W = Read/Write.

| Bit Position | Value | Description |
|--------------|-------|--|
| 7 | 0 | Reserved. |
| 6 TPCF | 0 | Do not transmit a pause control frame. |
| | 1 | Transmit pause control frame (full duplex mode). TPCF continually sends pause control frames until negated. |
| 5 THDF | 0 | Disable back pressure. |
| | 1 | EMAC asserts back pressure on the link. Back pressure causes preamble to be transmitted, raising carrier sense (half duplex mode). |
| 4 PARF | 0 | Only accept frames that meet preset criteria (i.e. address, CRC, length, etc.). |
| | 1 | All frames are received regardless of address, CRC, length, etc. |
| 3 RxFC | 0 | EMAC ignores received pause control frames. |
| | 1 | EMAC acts upon pause control frames received. |
| 2 TxFC | 0 | PAUSE control frames are NOT allowed to be transmitted. |
| | 1 | PAUSE control frames are allowed to be transmitted. |
| 1 TPAUSE | 0 | Do not force a pause condition. |
| | 1 | Force a pause condition while this bit is asserted. |
| 0 RxEN | 0 | Do not receive frames. |
| | 1 | Allow Receive frames to be received. |



EMAC Station Address Register

The EMAC Station Address register is used for two functions. In the address recognition logic for Receive frames, EMAC_STAD_0–EMAC_STAD_5 are matched against the 6-byte Destination Address (DA) field of the Receive frame.

EMAC_STAD_0 is matched against the first byte of the Receive frame, and EMAC_STAD_5 is matched against the sixth byte of the Receive frame. Bit 0 of EMAC_STAD_0 (STAD[40]) is matched against the first bit (Unicast/Multicast bit) of the first byte of the Receive frame. This bit ordering is used to logically map the PE-MACMII station address, as exemplified below.

EMAC_STAD0[7:0] contains STAD[47:40]

-
-

EMAC_STAD5[7:0] contains STAD[7:0]

The second function of the EMAC Station Address registers is to provide the Source Address (SA) field of Transmit Pause frames when these frames are transmitted by the EMAC. EMAC_STAD_0 provides the first byte of the 6-byte SA field and EMAC_STAD_5 provides the final byte of the SA field in order of transmission. The LSB is the first byte sent out. The EMAC Station Address register is detailed in Table 142.

Table 142. EMAC Station Address Register
(EMAC_STAD_0 = 0025h, EMAC_STAD_1 = 0026h, EMAC_STAD_2 = 0027h, EMAC_STAD_3 = 0028h, EMAC_STAD_4 = 0029h, EMAC_STAD_5 = 002Ah)

| Bit | 7 | 6 | 5 | 4 | 3 | 2 | 1 | 0 |
|-------------------|-----|-----|-----|-----|-----|-----|-----|-----|
| EMAC_STAD_0 Reset | 0 | 0 | 0 | 0 | 0 | 0 | 0 | 0 |
| EMAC_STAD_1 Reset | 0 | 0 | 0 | 0 | 0 | 0 | 0 | 0 |
| EMAC_STAD_2 Reset | 0 | 0 | 0 | 0 | 0 | 0 | 0 | 0 |
| EMAC_STAD_3 Reset | 0 | 0 | 0 | 0 | 0 | 0 | 0 | 0 |
| EMAC_STAD_4 Reset | 0 | 0 | 0 | 0 | 0 | 0 | 0 | 0 |
| EMAC_STAD_5 Reset | 0 | 0 | 0 | 0 | 0 | 0 | 0 | 0 |
| CPU Access | R/W | R/W | R/W | R/W | R/W | R/W | R/W | R/W |

Note: R/W = Read/Write.

| Bit Position | Value | Description |
|----------------------|-------------|---|
| [7:0] EMAC_STAD_x | 00h– FFh | This 48-bit station address comprises {EMAC_STAD_5, EMAC_STAD_4, EMAC_STAD_3, EMAC_STAD_2, EMAC_STAD_1, EMAC_STAD_0}. |



EMAC Transmit Pause Timer Value Register—Low and High Bytes

The Low and High bytes of the EMAC Transmit Pause Timer Value Register are inserted into outgoing pause control frames. See Tables 143 and 144.

Table 143. EMAC Transmit Pause Timer Value Register—Low Byte (EMAC_TPTV_L = 002Bh)

| Bit | 7 | 6 | 5 | 4 | 3 | 2 | 1 | 0 |
|-------------------|-----|-----|-----|-----|-----|-----|-----|-----|
| Reset | 0 | 0 | 0 | 0 | 0 | 0 | 0 | 0 |
| CPU Access | R/W | R/W | R/W | R/W | R/W | R/W | R/W | R/W |

Note: R/W = Read/Write.

| Bit Position | Value | Description |
|----------------------|-------------|--|
| [7:0] EMAC_TPTV_L | 00h– FFh | The 16-bit value, {EMAC_TPTV_H, EMAC_TPTV_L}, is inserted into outgoing pause control frames as the pause timer value upon asserting TPCF. |

Table 144. EMAC Transmit Pause Timer Value Register—High Byte (EMAC_TPTV_H = 002Ch)

| Bit | 7 | 6 | 5 | 4 | 3 | 2 | 1 | 0 |
|-------------------|-----|-----|-----|-----|-----|-----|-----|-----|
| Reset | 0 | 0 | 0 | 0 | 0 | 0 | 0 | 0 |
| CPU Access | R/W | R/W | R/W | R/W | R/W | R/W | R/W | R/W |

Note: R/W = Read/Write.

| Bit Position | Value | Description |
|----------------------|-------------|--|
| [7:0] EMAC_TPTV_H | 00h– FFh | The 16-bit value, {EMAC_TPTV_H, EMAC_TPTV_L}, is inserted into outgoing pause control frames as the pause timer value upon asserting TPCF. |



EMAC Interpacket Gap

EMAC Interpacket Gap Overview

Interpacket gap (IPG) is measured between the last nibble of the frame check sequence (FCS) and the first nibble of the preamble of the next packet. Three registers are available to fine tune the IPG, the EMAC_IPGT, EMAC_IPGR1, and the EMAC_IPGR2. The first register EMAC_IPGT determines the back-to-back Transmit IPG. The other two registers determine the non-back-to-back IPG in two parts. Table 145 shows the values for the EMAC_IPGT and the corresponding IPGs for both full-duplex and half-duplex modes.

Table 145. EMAC_IPGT Back-to-Back Settings for Full/Half Duplex Modes*

| MII, RMII/SMII, PMD (100Mbps) | | | MII, RMII/SMII (10Mbps) | | | ENDEC Mode (10Mbps) | | |
|-------------------------------------|-------------|-----------------|--------------------------------------|-------------|-----------------|--------------------------------------|-------------|-----------------|
| Clock Period = 40 nsec IPGT[6:0] | | | Clock Period = 400 nsec IPGT[6:0] | | | Clock Period = 100 nsec IPGT[6:0] | | |
| Half Duplex | Full Duplex | Interpacket Gap | Half Duplex | Full Duplex | Interpacket Gap | Half Duplex | Full Duplex | Interpacket Gap |
| | 0Dh | 0.12 μs | | 00h | 1.2 μs | | 10h | 1.9 μs |
| | 0Bh | 0.44 μs | | 08h | 4.4 μs | | 18h | 2.7 μs |
| | 0Ch | 0.60 μs | | 0Ch | 6.0 μs | | 20h | 3.5 μs |
| | 10h | 0.76 μs | | 10h | 7.5 μs | | 40h | 6.7 μs |
| 12h | 15h | 0.96 μs | 12h | 15h | 9.6 μs | 5Ah | 5Dh | 9.6 μs |
| | 20h | 1.40 μs | | 20h | 14.0 μs | | 20h | 13.0 μs |

Note: *The IEEE 802.3, 802.3(u) minimum values are shaded.

The equations for back-to-back Transmit IPG are determined by the following:

Full Duplex Mode (3 clocks + IPGT clocks) * clock period = IPG

Half Duplex Mode (6 clocks + IPGT clocks) * clock period = IPG

Table 146 shows the IPGR2 settings for the non-back-to-back packets.



Table 146. EMAC_IPGT Non-Back-to-Back Settings for Full/Half Duplex Modes*

| MII, RMII/SMII, PMD (100Mbps) | | MII, RMII/SMII (10Mbps) | | ENDEC Mode (10Mbps) | |
|----------------------------------|--------------------|----------------------------|--------------------|-------------------------|--------------------|
| Clock Period = 40 nsec | | Clock Period = 400 nsec | | Clock Period = 100 nsec | |
| IPGR2[6:0] | Interpacket Gap | IPGR2[6:0] | Interpacket Gap | IPGR2[6:0] | Interpacket Gap |
| 00h | 0.24µs | 00h | 2.4µs | 00h | 0.6µs |
| 10h | 0.88µs | 10h | 8.8µs | 10h | 2.2µs |
| 12h | 0.96µs | 12h | 9.6µs | 20h | 3.8µs |
| 20h | 1.52µs | 20h | 15.2µs | 40h | 7.0µs |
| 40h | 2.80µs | 40h | 28.0µs | 5Ah | 9.6µs |
| 7Fh | 5.32µs | 7Fh | 53.2µs | 7Fh | 13.3µs |

Note: *The IEEE 802.3, 802.3(u) minimum values are shaded.

A non-back-to-back Transmit IPG is determined by the following formula:

$$(6 \text{ clocks} + \text{IPGR2 clocks}) * \text{clock period} = \text{IPG}$$

The difference in values between Tables 145 and 146 is due to the asynchronous nature of the Carrier Sense (CRS). The CRS must undergo a 2-clock synchronization before the internal Tx state machine can detect it. This synchronization equates to a 6-clock intrinsic delay between packets instead of the 3-clock intrinsic delay in the back-to-back packet mode. More information covering this topic can be found in the IEEE 802.3/4.2.3.2.1 Carrier Deference section.

EMAC Interpacket Gap Register

The EMAC Interpacket Gap is a programmable field representing the interpacket gap (IPG) between back-to-back packets. It is the IPG parameter used in full-duplex and half-duplex modes between back-to-back packets. Set this field to the appropriate number of IPG octets. The default setting of 15h represents the minimum IPG of 0.96µs (at 100Mbps) or 9.6 µs (at 10Mbps). See Table 147.



Table 147. EMAC Interpacket Gap Register (EMAC_IPGT = 002Dh)

| Bit | 7 | 6 | 5 | 4 | 3 | 2 | 1 | 0 |
|-------------------|---|-----|-----|-----|-----|-----|-----|-----|
| Reset | 0 | 0 | 0 | 1 | 0 | 1 | 0 | 1 |
| CPU Access | R | R/W | R/W | R/W | R/W | R/W | R/W | R/W |

Note: R = Read Only; R/W = Read/Write

| Bit Position | Value | Description |
|---------------|-------------|------------------------------|
| 7 | 0 | Reserved. |
| [6:0] IPGT | 00h– 7Fh | The number of octets of IPG. |

EMAC Non-Back-To-Back IPG Register—Part 1

Part 1 of the EMAC Non-Back-To-Back IPG Register is a programmable field representing the optional carrier sense window referenced in IEEE 802.3/4.2.3.2.1 Carrier Deference. If a carrier is detected during the timing of IPGR1, the EMAC defers to the carrier. If, however, the carrier becomes active after IPGR1, the EMAC continues timing for IPGR2 and transmits, knowingly causing a collision. This collision acts to ensure fair access to the medium. Its range of values is 00h to IPGR2. See Table 148. The default setting of 0Ch represents the Carrier Sense Window Referencing depicted in IEEE 802.3, Section 4.2.3.2.1.

Table 148. EMAC Non-Back-To-Back IPG Register—Part 1 (EMAC_IPGR1 = 002Eh)

| Bit | 7 | 6 | 5 | 4 | 3 | 2 | 1 | 0 |
|-------------------|-----|-----|-----|-----|-----|-----|-----|-----|
| Reset | 0 | 0 | 0 | 0 | 1 | 1 | 0 | 0 |
| CPU Access | R/W | R/W | R/W | R/W | R/W | R/W | R/W | R/W |

Note: R/W = Read/Write

| Bit Position | Value | Description |
|-----------------|-------------|---|
| 7 | 0 | Reserved. |
| [6:0] IPGR 1 | 00h– 7Fh | This is a programmable field representing the optional carrier sense window referenced in IEEE 802.3/4.2.3.2.1 Carrier Deference. |



EMAC Non-Back-To-Back IPG Register—Part 2

Part 2 of the EMAC Non-Back-To-Back IPG Register is a programmable field representing the non-back-to-back interpacket gap. Its default is 12h, which represents the minimum IPG of 0.96 μs at 100Mbps or 9.6 μs at 10Mbps. See Table 149.

Table 149. EMAC Non-Back-To-Back IPG Register—Part 2 (EMAC_IPGR2 = 002Fh)

| Bit | 7 | 6 | 5 | 4 | 3 | 2 | 1 | 0 |
|-------------------|---|-----|-----|-----|-----|-----|-----|-----|
| Reset | 0 | 0 | 0 | 1 | 0 | 0 | 1 | 0 |
| CPU Access | R | R/W | R/W | R/W | R/W | R/W | R/W | R/W |

Note: R = Read Only; R/W = Read/Write

| Bit Position | Value | Description |
|----------------|-------------|---|
| 7 | 0 | Reserved. |
| [6:0] IPGR2 | 00h– 7Fh | This is a programmable field representing the non-back-to-back interpacket gap. |

EMAC Maximum Frame Length Register—Low and High Bytes

The 16-bit field resets to 0600h, which represents a maximum Receive frame of 1536 octets. An untagged maximum size Ethernet frame is 1518 octets. A tagged frame adds four octets for a total of 1522 octets. If a shorter maximum length restriction is more appropriate, program this field. See Tables 150 and 151.

- **Note:** If a proprietary header is allowed, this field should be adjusted accordingly. For example, if 12-byte headers are prepended to frames, MAXF should be set to 1524 octets to allow the maximum VLAN tagged frame plus the 12-byte header.



**Table 150. EMAC Maximum Frame Length Register—Low Byte
(EMAC_MAXF_L = 0030h)**

| Bit | 7 | 6 | 5 | 4 | 3 | 2 | 1 | 0 |
|-------------------|-----|-----|-----|-----|-----|-----|-----|-----|
| Reset | 0 | 0 | 0 | 0 | 0 | 0 | 0 | 0 |
| CPU Access | R/W | R/W | R/W | R/W | R/W | R/W | R/W | R/W |

Note: R/W = Read/Write.

| Bit Position | Value | Description |
|----------------------|-------------|---|
| [7:0] EMAC_MAXF_L | 00h– FFh | These bits represent the Low byte of the 2-byte MAXF value, {EMAC_MAXF_H, EMAC_MAXF_L}. Bit 7 is bit 7 of the 16-bit value. Bit 0 is bit 0 (lsb) of the 16-bit value. |

**Table 151. EMAC Maximum Frame Length Register—High Byte
(EMAC_MAXF_H = 0031h)**

| Bit | 7 | 6 | 5 | 4 | 3 | 2 | 1 | 0 |
|-------------------|-----|-----|-----|-----|-----|-----|-----|-----|
| Reset | 0 | 0 | 0 | 0 | 0 | 1 | 1 | 0 |
| CPU Access | R/W | R/W | R/W | R/W | R/W | R/W | R/W | R/W |

Note: R/W = Read/Write.

| Bit Position | Value | Description |
|----------------------|-------------|---|
| [7:0] EMAC_MAXF_H | 00h– FFh | These bits represent the High byte of the 2-byte MAXF value, {EMAC_MAXF_H, EMAC_MAXF_L}. Bit 7 is bit 15 (msb) of the 16-bit value. Bit 0 is bit 8 of the 16-bit value. |



EMAC Address Filter Register

The EMAC Address Filter Register functions as a filter to control promiscuous mode, and multicast and broadcast messaging. See Table 152.

Table 152. EMAC Address Filter Register
(EMAC_AFR = 0032h)

| Bit | 7 | 6 | 5 | 4 | 3 | 2 | 1 | 0 |
|-------------------|---|---|---|---|-----|-----|-----|-----|
| Reset | 0 | 0 | 0 | 0 | 0 | 0 | 0 | 0 |
| CPU Access | R | R | R | R | R/W | R/W | R/W | R/W |

Note: R = Read Only; R/W = Read/Write.

| Bit Position | Value | Description |
|--------------|-------|---|
| [7:4] | 0h | Reserved. |
| 3 PROM | 1 | Enable Promiscuous Mode. Receive all incoming packets regardless of station address. Disables station address filtering. |
| | 0 | Disable Promiscuous Mode. |
| 2 MC | 1 | Accept any multicast message. A multicast packet is determined by the first bit in the destination address. If the first LSB is a 1, it is a group address and is globally or locally administered depending on the 2nd bit. See IEEE 802.3/3.2.3 for more information. |
| | 0 | Do not accept multicast messages of any type. |
| 1 QMC | 1 | Accept only qualified multicast (QMC) messages as determined by the hash table. |
| | 0 | Do not accept qualified multicast messages. |
| 0 BC | 1 | Accept broadcast messages. Broadcast messages have the destination address set to FFFFFFFFh. |
| | 0 | Do not accept broadcast messages. |



EMAC Hash Table Register

The EMAC Hash Table Register represents the 8x8 hash table matrix. This table is used as an option to select between different multicast addresses. If a multicast address is received, the first 6 bits of the CRC are decoded and added to a table that points to a single bit within the hash table matrix. If the selected bit = 1, the multicast packet is accepted. If the bit = 0, the multicast packet is rejected. See Table 153.

Table 153. EMAC Hash Table Register
(EMAC_HTBL_0 = 0033h, EMAC_HTBL_1 = 0034h, EMAC_HTBL_2 = 0035h,
EMAC_HTBL_3 = 0036h, EMAC_HTBL_4 = 0037h, EMAC_HTBL_5 = 0038h,
EMAC_HTBL_6 = 0039h, EMAC_HTBL_7 = 003Ah)

| Bit | 7 | 6 | 5 | 4 | 3 | 2 | 1 | 0 |
|-------------------|-----|-----|-----|-----|-----|-----|-----|-----|
| EMAC_HTBL_0 Reset | 0 | 0 | 0 | 0 | 0 | 0 | 0 | 0 |
| EMAC_HTBL_1 Reset | 0 | 0 | 0 | 0 | 0 | 0 | 0 | 0 |
| EMAC_HTBL_2 Reset | 0 | 0 | 0 | 0 | 0 | 0 | 0 | 0 |
| EMAC_HTBL_3 Reset | 0 | 0 | 0 | 0 | 0 | 0 | 0 | 0 |
| EMAC_HTBL_4 Reset | 0 | 0 | 0 | 0 | 0 | 0 | 0 | 0 |
| EMAC_HTBL_5 Reset | 0 | 0 | 0 | 0 | 0 | 0 | 0 | 0 |
| EMAC_HTBL_6 Reset | 0 | 0 | 0 | 0 | 0 | 0 | 0 | 0 |
| EMAC_HTBL_7 Reset | 0 | 0 | 0 | 0 | 0 | 0 | 0 | 0 |
| CPU Access | R/W | R/W | R/W | R/W | R/W | R/W | R/W | R/W |

Note: R/W = Read/Write

| Bit Position | Value | Description |
|----------------------|-------------|--|
| [7:0] EMAC_HTBL_x | 00h– FFh | This field is the hash table. The 64-bit hash table is {EMAC_HTBL_7, EMAC_HTBL_6, EMAC_HTBL_5, EMAC_HTBL_4, EMAC_HTBL_3, EMAC_HTBL_2, EMAC_HTBL_1, EMAC_HTBL_0}. |



EMAC MII Management Register

The EMAC MII Management Register is used to control the external PHY attached to the MII. See Table 154.

Table 154. EMAC MII Management Register (EMAC_MIIMGT = 003Bh)

| Bit | 7 | 6 | 5 | 4 | 3 | 2 | 1 | 0 |
|-------------------|-----|-----|-----|-----|-----|-----|-----|-----|
| Reset | 0 | 0 | 0 | 0 | 0 | 0 | 0 | 0 |
| CPU Access | R/W | R/W | R/W | R/W | R/W | R/W | R/W | R/W |

Note: R/W = Read/Write.

| Bit Position | Value | Description |
|--------------|-------|---|
| 7 LCTLD | 1 | Rising edge causes the CTLD control data to be transmitted to external PHY if MII is not busy. This bit is self clearing. |
| | 0 | No operation. |
| 6 RSTAT | 1 | Rising edge causes status to be read from external PHY via PRSD[15:0] bus if MII is not busy. This bit is self clearing. |
| | 0 | No operation. |
| 6 SCINC | 1 | Scan PHY address increments upon SCAN cycle. The SCAN bit must also be set for the PHY address to increment after each scan. The scanning starts at the EmacFiad and increments up to 1fh. It then rolls back to the EmacFiad address. |
| | 0 | Normal operation. |
| 5 SCAN | 1 | Perform continuous Read cycles via MII management. While in scan mode, the EmacStat[MGTDONE] bit is set when the current PHY Read has completed. At this time, the EmacPrsd register holds the Read data and the EmacMIStat[4:0] holds the address of the PHY for which the EmacPrsd data pertains. |
| | 0 | Normal operation. |
| 4 SPRE | 1 | Suppress MDO preamble. |
| | 0 | Normal preamble. |



| Bit Position | Value | Description |
|---------------|-------|---|
| [2:0] CLKS | | Programmable divisor that produces MDC from SCLK. |
| | 000 | MDC = SCLK ÷ 4. |
| | 001 | MDC = SCLK ÷ 4. |
| | 010 | MDC = SCLK ÷ 6. |
| | 011 | MDC = SCLK ÷ 8. |
| | 100 | MDC = SCLK ÷ 10. |
| | 101 | MDC = SCLK ÷ 14. |
| | 110 | MDC = SCLK ÷ 20. |
| | 111 | MDC = SCLK ÷ 28. |

EMAC PHY Configuration Data Register—Low Byte

The Low Byte of the EMAC PHY Configuration Data Register represents the configuration data written to the external PHY. See Table 155.

Table 155. EMAC PHY Configuration Data Register—Low Byte (EMAC_CTLD_L = 003Ch)

| Bit | 7 | 6 | 5 | 4 | 3 | 2 | 1 | 0 |
|-------------------|-----|-----|-----|-----|-----|-----|-----|-----|
| Reset | 0 | 0 | 0 | 0 | 0 | 0 | 0 | 0 |
| CPU Access | R/W | R/W | R/W | R/W | R/W | R/W | R/W | R/W |

Note: R/W = Read/Write.

| Bit Position | Value | Description |
|----------------------|-------------|---|
| [7:0] EMAC_CTLD_L | 00h– FFh | These bits represent the Low byte of the 2-byte PHY configuration data value, {EMAC_CTLD_H, EMAC_CTLD_L}. Bit 7 is bit 7 of the 16-bit value. Bit 0 is bit 0 (lsb) of the 16-bit value. |



EMAC PHY Configuration Data Register—High Byte

The High Byte of the EMAC PHY Configuration Data Register represents the configuration data written to the external PHY. See Table 156.

Table 156. EMAC PHY Configuration Data Register—High Byte (EMAC_CTLD_H = 003Dh)

| Bit | 7 | 6 | 5 | 4 | 3 | 2 | 1 | 0 |
|-------------------|-----|-----|-----|-----|-----|-----|-----|-----|
| Reset | 0 | 0 | 0 | 0 | 0 | 0 | 0 | 0 |
| CPU Access | R/W | R/W | R/W | R/W | R/W | R/W | R/W | R/W |

Note: R/W = Read/Write.

| Bit Position | Value | Description |
|----------------------|-------------|---|
| [7:0] EMAC_CTLD_H | 00h– FFh | These bits represent the High byte of the 2-byte PHY configuration data value, {EMAC_CTLD_H, EMAC_CTLD_L}. Bit 7 is bit 15 (msb) of the 16-bit value. Bit 0 is bit 8 of the 16-bit value. |

EMAC PHY Address Register

The EMAC PHY Address Register allows access to the external PHY registers. See Table 157.

Table 157. EMAC PHY Address Register (EMAC_RGAD = 003Eh)

| Bit | 7 | 6 | 5 | 4 | 3 | 2 | 1 | 0 |
|-------------------|---|---|---|-----|-----|-----|-----|-----|
| Reset | 0 | 0 | 0 | 0 | 0 | 0 | 0 | 0 |
| CPU Access | R | R | R | R/W | R/W | R/W | R/W | R/W |

Note: R = Read Only; R/W = Read/Write.

| Bit Position | Value | Description |
|---------------|-------------|--|
| [7:5] | 000 | Reserved. |
| [4:0] RGAD | 00h– 1Fh | Programmable 5-bit value which selects address within the selected external PHY. |



EMAC PHY Unit Select Address Register

The EMAC PHY Unit Select Address Register allows the selection of multiple connected external PHY devices. See Table 158.

**Table 158. EMAC PHY Unit Select Address Register
(EMAC_FIAD = 003Fh)**

| Bit | 7 | 6 | 5 | 4 | 3 | 2 | 1 | 0 |
|-------------------|---|---|---|-----|-----|-----|-----|-----|
| Reset | 0 | 0 | 0 | 0 | 0 | 0 | 0 | 0 |
| CPU Access | R | R | R | R/W | R/W | R/W | R/W | R/W |

Note: R = Read Only; R/W = Read/Write.

| Bit Position | Value | Description |
|---------------|-------------|--|
| [7:5] | 000 | Reserved. |
| [4:0] FIAD | 00h– 1Fh | Programmable 5-bit value that selects an external PHY. |

EMAC Transmit Polling Timer Register

This register sets the Transmit Polling Period in increments of $TPTMR = SYSCLK \div 256$. Whenever this register is written, the status of the Transmit Buffer Descriptor is checked to determine if the EMAC owns the Transmit buffer. It then rechecks this status every TPTMR (calculated by $TPTMR * EMAC_PTMR[7:0]$). The Transmit Polling Timer is disabled if this register is set to 00h (which also disables the transmitting of packets). If a transmission is in progress when EMAC_PTMR is set to 00h, the transmission will complete. See Table 159.

**Table 159. EMAC Transmit Polling Timer Register
(EMAC_PTMR = 0040h)**

| Bit | 7 | 6 | 5 | 4 | 3 | 2 | 1 | 0 |
|-------------------|-----|-----|-----|-----|-----|-----|-----|-----|
| Reset | 0 | 0 | 0 | 0 | 0 | 0 | 0 | 0 |
| CPU Access | R/W | R/W | R/W | R/W | R/W | R/W | R/W | R/W |

Note: R/W = Read/Write.

| Bit Position | Value | Description |
|--------------------|-------------|------------------------------|
| [7:0] EMAC_PTMR | 00h– FFh | The Transmit polling period. |



EMAC Reset Control Register

The bit values in the EMAC Reset Control Register are not self-clearing bits. The user is responsible for controlling their state. See Table 160.

Table 160. EMAC Reset Control Register (EMAC_RST = 0041h)

| Bit | 7 | 6 | 5 | 4 | 3 | 2 | 1 | 0 |
|-------------------|---|---|-----|-----|-----|-----|-----|-----|
| Reset | 0 | 0 | 1 | 0 | 0 | 0 | 0 | 0 |
| CPU Access | R | R | R/W | R/W | R/W | R/W | R/W | R/W |

Note: R = Read Only; R/W = Read/Write.

| Bit Position | Value | Description |
|--------------|-------|--|
| [7:6] | 00 | Reserved. |
| 5 SRST | 1 | Software Reset Active—resets Receive, Transmit, EMAC Control and EMAC MII_MGT functions. |
| | 0 | Normal operation. |
| 4 HRTFN | 1 | Reset Transmit function. |
| | 0 | Normal operation. |
| 3 HRRFN | 1 | Reset Receive function. |
| | 0 | Normal operation. |
| 2 HRTMC | 1 | Reset EMAC Transmit Control function. |
| | 0 | Normal operation. |
| 1 HRRMC | 1 | Reset EMAC Receive Control function. |
| | 0 | Normal operation. |
| 0 HRMGT | 1 | Reset EMAC Management function. |
| | 0 | Normal operation. |



EMAC Transmit Lower Boundary Pointer Register—Low and High Bytes

The EMAC Transmit Lower Boundary Pointer is set to the start of the Transmit buffer in EMAC shared memory. See Tables 161 and 162.

Table 161. EMAC Transmit Lower Boundary Pointer Register—Low Byte (EMAC_TLBP_L = 0042h)

| Bit | 7 | 6 | 5 | 4 | 3 | 2 | 1 | 0 |
|-------------------|-----|-----|-----|-----|-----|-----|-----|-----|
| Reset | 0 | 0 | 0 | 0 | 0 | 0 | 0 | 0 |
| CPU Access | R/W | R/W | R/W | R/W | R/W | R/W | R/W | R/W |

Note: R/W = Read/Write.

| Bit Position | Value | Description |
|----------------------|-------------|--|
| [7:0] EMAC_TLBP_L | 00h– FFh | These bits represent the Low byte of the 2-byte Transmit Lower Boundary Pointer value, {EMAC_TLBP_H, EMAC_TLBP_L}. Bit 7 is bit 7 of the 16-bit value. Bit 0 is bit 0 (lsb) of the 16-bit value. |

Table 162. EMAC Transmit Lower Boundary Pointer Register—High Byte (EMAC_TLBP_H = 0043h)*

| Bit | 7 | 6 | 5 | 4 | 3 | 2 | 1 | 0 |
|-------------------|---|---|---|-----|-----|-----|-----|-----|
| Reset | 1 | 1 | 0 | 0 | 0 | 0 | 0 | 0 |
| CPU Access | R | R | R | R/W | R/W | R/W | R/W | R/W |

Note: R/W = Read/Write.

| Bit Position | Value | Description |
|----------------------|-------------|--|
| [7:0] EMAC_TLBP_H | 00h– FFh | These bits represent the High byte of the 2-byte Transmit Lower Boundary Pointer value, {EMAC_TLBP_H, EMAC_TLBP_L}. Bit 7 is bit 15 (msb) of the 16-bit value. Bit 0 is bit 8 of the 16-bit value. |

Note: *Bits 7:5 are not used by the EMAC; these bits return 000.



EMAC Boundary Pointer Register—Low and High Bytes

The Boundary Pointer is set to the start of the Receive buffer (end of Transmit buffer +1) in EMAC shared memory. This pointer is 24 bits and determined by {RAM_ADDR_U, EMAC_BP_H, EMAC_BP_L}. The upper 3 bits of the EMAC_BP_H register are hard-wired inside the eZ80F91 device to locate the base of EMAC shared memory. The last 5 bits of the EMAC_BP_L register value are hard-wired to keep the addressing aligned to a 32-byte boundary. See Tables 163 and 164.

Table 163. EMAC Boundary Pointer Register—Low Byte (EMAC_BP_L = 0044h)

| Bit | 7 | 6 | 5 | 4 | 3 | 2 | 1 | 0 |
|-------------------|-----|-----|-----|---|---|---|---|---|
| Reset | 0 | 0 | 0 | 0 | 0 | 0 | 0 | 0 |
| CPU Access | R/W | R/W | R/W | R | R | R | R | R |

Note: R = Read Only, R/W = Read/Write.

| Bit Position | Value | Description |
|--------------------|-------------|---|
| [7:0] EMAC_BP_L | 00h– FFh | These bits represent the Low byte of the 3-byte EMAC Boundary Pointer value, {EMAC_BP_U, EMAC_BP_H, EMAC_BP_L}. Bit 7 is bit 7 of the 24-bit value. Bit 0 is bit 0 of the 24-bit value. |

Table 164. EMAC Boundary Pointer Register—High Byte (EMAC_BP_H = 0045h)

| Bit | 15:13 | | | 12:8 | | | | |
|-------------------|-------|---|---|------|-----|-----|-----|-----|
| Reset | 1 | 1 | 0 | 0 | 0 | 0 | 0 | 0 |
| CPU Access | R | R | R | R/W | R/W | R/W | R/W | R/W |

Note: R = Read Only, R/W = Read/Write.

| Bit Position | Value | Description |
|--------------------|-------------|---|
| [7:0] EMAC_BP_H | 00h– FFh | These bits represent the High byte of the 3-byte EMAC Boundary Pointer value, {EMAC_BP_U, EMAC_BP_H, EMAC_BP_L}. Bit 7 is bit 15 of the 24-bit value. Bit 0 is bit 8 of the 24-bit value. |



EMAC Boundary Pointer Register—Upper Byte

The EMAC Boundary Pointer Register maps directly to the RAM_ADDR_U register within the eZ80F91 device. This register value is Read Only. See Table 165.

Table 165. EMAC Boundary Pointer Register—Upper Byte (EMAC_BP_U = 0046h)

| Bit | 7 | 6 | 5 | 4 | 3 | 2 | 1 | 0 |
|------------|---|---|---|---|---|---|---|---|
| Reset | 1 | 1 | 1 | 1 | 1 | 1 | 1 | 1 |
| CPU Access | R | R | R | R | R | R | R | R |

Note: R = Read Only.

| Bit Position | Value | Description |
|--------------------|-------------|---|
| [7:0] EMAC_BP_U | 00h– FFh | These bits represent the upper byte of the 3-byte EMAC Boundary Pointer value, {EMAC_BP_U, EMAC_BP_H, EMAC_BP_L}. Bit 7 is bit 23 of the 24-bit value. Bit 0 is bit 16 of the 24-bit value. |

EMAC Receive High Boundary Pointer Register—Low and High Bytes

The Receive High Boundary Pointer Register should be set to the end of the Receive buffer +1 in EMAC shared memory. This RHBP uses the same RAM_ADDR_U as the EMAC_BP_U pointer above. See Tables 166 and 167.

Table 166. EMAC Receive High Boundary Pointer Register—Low Byte (EMAC_RHBP_L = 0047h)

| Bit | 7 | 6 | 5 | 4 | 3 | 2 | 1 | 0 |
|------------|-----|-----|-----|---|---|---|---|---|
| Reset | 0 | 0 | 0 | 0 | 0 | 0 | 0 | 0 |
| CPU Access | R/W | R/W | R/W | R | R | R | R | R |

Note: R = Read Only, R/W = Read/Write

| Bit Position | Value | Description |
|----------------------|-------------|---|
| [7:0] EMAC_RHBP_L | 00h– E0h | These bits represent the Low byte of the 2-byte EMAC Receive High Boundary Pointer value, {EMAC_RHBP_H, EMAC_RHBP_L}. Bit 7 is bit 7 of the 16-bit value. Bit 0 is bit 0 (lsb) of the 16-bit value. |



Table 167. EMAC Receive High Boundary Pointer Register—High Byte (EMAC_RHBP_H = 0048h)

| Bit | 7 | 6 | 5 | 4 | 3 | 2 | 1 | 0 |
|-------------------|---|---|---|-----|-----|-----|-----|-----|
| Reset | 1 | 1 | 0 | 0 | 0 | 0 | 0 | 0 |
| CPU Access | R | R | R | R/W | R/W | R/W | R/W | R/W |

Note: R = Read Only, R/W = Read/Write

| Bit Position | Value | Description |
|----------------------|-------------|---|
| [7:0] EMAC_RHBP_H | 00h– FFh | These bits represent the High byte of the 2-byte EMAC Receive High Boundary Pointer value, {EMAC_RHBP_H, EMAC_RHBP_L}. Bit 7 is bit 15 (msb) of the 16-bit value. Bit 0 is bit 8 of the 16-bit value. |

Note: *Bits 7:5 are not used by the EMAC; these bits return 000.

EMAC Receive Read Pointer Register—Low and High Bytes

The Receive Read Pointer Register should be initialized to the EMAC_BP value (start of the Receive buffer). This register points to where the next Receive packet is read from. The EMAC_BP[12:5] is loaded into this register whenever the EMAC_RST [(HRRFN) is set to 1. The RxDMA block uses the Emac_Rrp[12:5] to compare to EmacRwp[12:5] for determining how many buffers remain. The result equates to the EmacBlksLeft register. See Tables 168 and 169.

Table 168. EMAC Receive Read Pointer Register—Low Byte (EMAC_RRP_L = 0049h)

| Bit | 7 | 6 | 5 | 4 | 3 | 2 | 1 | 0 |
|-------------------|-----|-----|-----|---|---|---|---|---|
| Reset | 0 | 0 | 0 | 0 | 0 | 0 | 0 | 0 |
| CPU Access | R/W | R/W | R/W | R | R | R | R | R |

Note: R = Read Only, R/W = Read/Write

| Bit Position | Value | Description |
|---------------------|-------------|--|
| [7:0] EMAC_RRP_L | 00h– FFh | These bits represent the Low byte of the 2-byte EMAC Receive Read Pointer value, {EMAC_RRP_H, EMAC_RRP_L}. Bit 7 is bit 7 of the 16-bit value. Bit 0 is bit 0 (lsb) of the 16-bit value. |



Table 169. EMAC Receive Read Pointer Register—High Byte (EMAC_RRP_H = 004Ah)

| Bit | 7 | 6 | 5 | 4 | 3 | 2 | 1 | 0 |
|------------|---|---|---|-----|-----|-----|-----|-----|
| Reset | 0 | 0 | 0 | 0 | 0 | 0 | 0 | 0 |
| CPU Access | R | R | R | R/W | R/W | R/W | R/W | R/W |

Note: R = Read Only, R/W = Read/Write

| Bit Position | Value | Description |
|-------------------------|-------------|--|
| [7:0] EMAC_RRP_ H | 00h– FFh | These bits represent the High byte of the 2-byte EMAC Receive Read Pointer value, {EMAC_RRP_H, EMAC_RRP_L}. Bit 7 is bit 15 (msb) of the 16-bit value. Bit 0 is bit 8 of the 16-bit value. |

EMAC Buffer Size Register

The lower six bits of this register set the level at which the EMAC either transmits a pause control frame or jams the Ethernet bus, depending on the mode selected. When these bits each contain a zero, this feature is disabled.

In Full Duplex Mode, a Pause Control Frame is transmitted as a one-shot operation. The software must free up a number of Rx buffers so that the number of buffers remaining, EmacBlksLeft, is greater than TCPF_LEV.

In Half Duplex Mode, the EMAC jams the Ethernet by sending a continuous stream of hexadecimal 5s (5fh). When the software frees up the Rx buffers and the number of buffers remaining, EmacBlksLeft, is greater than TCPF_LEV, the EMAC stops jamming.



**Table 170. EMAC Buffer Size Register
(EMAC_BUFSZ = 004Bh)**

| Bit | 7 | 6 | 5 | 4 | 3 | 2 | 1 | 0 |
|-------------------|-----|-----|-----|-----|-----|-----|-----|-----|
| Reset | 0 | 0 | 0 | 0 | 0 | 0 | 0 | 0 |
| CPU Access | R/W | R/W | R/W | R/W | R/W | R/W | R/W | R/W |

Note: R/W = Read/Write.

| Bit Position | Value | Description |
|-------------------|-------------|--|
| [7:6] BUFSZ | 00 | Set EMAC Rx/Tx buffer size to 256 bytes. |
| | 01 | Set EMAC Rx/Tx buffer size to 128 bytes. |
| | 10 | Set EMAC Rx/Tx buffer size to 64 bytes. |
| | 11 | Set EMAC Rx/Tx buffer size to 32 bytes. |
| [5:0] TPCF_LEV | 00h– 3Fh | Transmit Pause Control Frame level.* |

Note: *00h disables the hardware-generated Transmit Pause Control Frame.

EMAC Interrupt Enable Register

Enabling the Receive Overrun interrupt allows software to detect an overrun condition as soon as it occurs. If this interrupt is not set, then an overrun cannot be detected until the software processes the Receive packet with the overrun and checks the Receive status in the Rx descriptor table. Because the receiver is disabled by an overrun error until the Rx_OVR bit is cleared in the EMAC_ISTAT register, this packet is the final packet in the Receive buffer. To reenble the receiver before all of the Receive packets are processed and the Receive buffer is empty, software can enable this interrupt to detect the overrun condition early. As it processes the Receive packets, it can reenble the receiver when the number of free buffers is greater than the number of minimum buffers. See Table 171.



**Table 171. EMAC Interrupt Enable Register
(EMAC_IEN = 004Ch)**

| Bit | 7 | 6 | 5 | 4 | 3 | 2 | 1 | 0 |
|-------------------|-----|-----|-----|-----|-----|-----|-----|-----|
| Reset | 0 | 0 | 0 | 0 | 0 | 0 | 0 | 0 |
| CPU Access | R/W | R/W | R/W | R/W | R/W | R/W | R/W | R/W |

Note: R/W = Read/Write.

| Bit Position | Value | Description |
|---------------|-------|--|
| 7 TxFSMERR | 1 | Enable Transmit State Machine Error Interrupt (system interrupt). |
| | 0 | Disable Transmit State Machine Error Interrupt (system interrupt). |
| 6 MGTDONE | 1 | Enable MII Mgmt. Done Interrupt (system Interrupt). |
| | 0 | Disable MII Mgmt. Done Interrupt (system Interrupt). |
| 5 Rx_CF | 1 | Enable Receive Control Frame Interrupt (Receive interrupt). |
| | 0 | Disable Receive Control Frame Interrupt (Receive interrupt). |
| 4 Rx_PCF | 1 | Enable Receive Pause Control Frame interrupt (Receive interrupt). |
| | 0 | Disable Receive Pause Control Frame interrupt (Receive interrupt). |
| 3 Rx_DONE | 1 | Enable Receive Done interrupt (Receive interrupt). |
| | 0 | Disable Receive Done interrupt (Receive interrupt). |
| 2 Rx_OVR | 1 | Enable Receive Overrun interrupt (System interrupt). |
| | 0 | Disable Receive Overrun interrupt (System interrupt). |
| 1 Tx_CF | 1 | Enable Transmit Control Frame Interrupt (Transmit interrupt). |
| | 0 | Disable Transmit Control Frame Interrupt (Transmit interrupt). |
| 0 Tx_DONE | 1 | Enable Transmit Done interrupt (Transmit interrupt). |
| | 0 | Disable Transmit Done Interrupt (Transmit interrupt). |

EMAC Interrupt Status Register

When a Receive overrun occurs, all incoming packets are ignored until the Rx_OVR_STAT status bit is cleared by software. Consequently, software controls when the receiver can be reenabled after an overrun. Enable the Rx_OVR interrupt to detect overrun conditions when they occur. Clear this condition when the Rx buffers are freed to avoid additional overrun errors. See Table 172.

Note: Status bits are not self-clearing. Each status bit is cleared by writing a 1 into the selected bit.

Table 172. EMAC Interrupt Status Register (EMAC_ISTAT = 004Dh)

| Bit | 7 | 6 | 5 | 4 | 3 | 2 | 1 | 0 |
|------------|-----|-----|-----|-----|-----|-----|-----|-----|
| Reset | 0 | 0 | 0 | 0 | 0 | 0 | 0 | 0 |
| CPU Access | R/W | R/W | R/W | R/W | R/W | R/W | R/W | R/W |

Note: R/W = Read/Write.

| Bit Position | Value | Description |
|--------------------|-------|--|
| 7 TxFSMERR_STAT | 1 | An internal error occurs in the EMAC Transmit path. The Transmit path must be reset to reset this error condition. |
| | 0 | Normal operation—no Transmit state machine errors. |
| 6 MGTDONE_STAT | 1 | The MII Mgmt. interrupt has completed a Read (RSTAT or SCAN) or a Write (LDCTLD) access to the PHY. |
| | 0 | The MII Mgmt. interrupt does not occur. |
| 5 Rx_CF_STAT | 1 | Receive Control Frame interrupt (Receive Interrupt) occurs. |
| | 0 | Receive Control Frame interrupt does not occur. |
| 4 Rx_PCF_STAT | 1 | Receive Pause Control Frame interrupt (Receive Interrupt) occurs. |
| | 0 | Disable Receive Pause Control Frame interrupt (Receive Interrupt) does not occur. |
| 3 Rx_DONE_STAT | 1 | Receive Done interrupt (Receive Interrupt) occurs. |
| | 0 | Disable Receive Done interrupt (Receive Interrupt) does not occur. |
| 2 Rx_OVR_STAT | 1 | Receive Overrun interrupt (System Interrupt) occurs. |
| | 0 | Receive Overrun interrupt (System Interrupt) does not occur. |



| Bit Position | Value | Description |
|-------------------|-------|---|
| 1 Tx_CF_STAT | 1 | Transmit Control Frame Interrupt (Transmit Interrupt) occurs. |
| | 0 | Transmit Control Frame Interrupt (Transmit Interrupt) does not occur. |
| 0 Tx_DONE_STAT | 1 | Transmit Done interrupt (Transmit Interrupt) occurs. |
| | 0 | Transmit Done interrupt (Transmit Interrupt) does not occur. |

EMAC PHY Read Status Data Register—Low and High Bytes

The PHY MII Management Data Register is where the data Read from the PHY is stored. See Tables 173 and 174.

Table 173. EMAC PHY Read Status Data Register—Low Byte (EMAC_PRSD_L = 004Eh)

| Bit | 7 | 6 | 5 | 4 | 3 | 2 | 1 | 0 |
|-------------------|---|---|---|---|---|---|---|---|
| Reset | 0 | 0 | 0 | 0 | 0 | 0 | 0 | 0 |
| CPU Access | R | R | R | R | R | R | R | R |

Note: R = Read Only.

| Bit Position | Value | Description |
|----------------------|-------------|--|
| [7:0] EMAC_PRSD_L | 00h– FFh | These bits represent the Low byte of the 2-byte EMAC PHY Read Status Data value, {EMAC_PRSD_H, EMAC_PRSD_L}. Bit 7 is bit 7 of the 16-bit value. Bit 0 is bit 0 (lsb) of the 16-bit value. |



**Table 174. EMAC PHY Read Status Data Register—High Byte
(EMAC_PRSD_H = 004Fh)**

| Bit | 7 | 6 | 5 | 4 | 3 | 2 | 1 | 0 |
|-------------------|---|---|---|---|---|---|---|---|
| Reset | 0 | 0 | 0 | 0 | 0 | 0 | 0 | 0 |
| CPU Access | R | R | R | R | R | R | R | R |

Note: R = Read Only.

| Bit Position | Value | Description |
|----------------------|-------------|--|
| [7:0] EMAC_PRSD_H | 00h– FFh | These bits represent the High byte of the 2-byte EMAC PHY Read Status Data value, {EMAC_PRSD_H, EMAC_PRSD_L}. Bit 7 is bit 15 (msb) of the 16-bit value. Bit 0 is bit 8 of the 16-bit value. |

EMAC MII Status Register

The EMAC MII Status Register is used to determine the current state of the external PHY device. See Table 175.

**Table 175. EMAC MII Status Register
(EMAC_MIISTAT = 0050h)**

| Bit | 7 | 6 | 5 | 4 | 3 | 2 | 1 | 0 |
|-------------------|---|---|---|---|---|---|---|---|
| Reset | 0 | 0 | 0 | 0 | 0 | 0 | 0 | 0 |
| CPU Access | R | R | R | R | R | R | R | R |

Note: R = Read Only.

| Bit Position | Value | Description |
|--------------|-------|---|
| 7 BUSY | 1 | MII management operation in progress—Busy. This status bit goes busy whenever the LCTLD (PHY Write) or the RSTAT (PHY Read) is set in the EMAC_MIIMGT register. It is negated when the Write or Read operation to the PHY has completed. In SCAN mode, the BUSY will be asserted until the SCAN is disabled. Use the EmacIStat[MGTDONE] interrupt status bit to determine when the data is valid. |
| | 0 | Not Busy. |
| 6 MIILF | 1 | Local copy of PHY Link fail bit. |
| | 0 | PHY Link OK. |



| | | |
|----------------|-------------|---|
| 5 NVALID | 1 | MII Scan result is not valid Emac_PRSD is invalid |
| | 0 | Emac_PRSD is valid. |
| [4:0] RDADR | 00h– 1Fh | Denotes PHY addressed in current scan cycle. |

EMAC Receive Write Pointer Register—Low Byte

The Read Only Receive-Write-Pointer register reports the current RxDMA Receive Write pointer. This pointer gets initialized to EmacTLBP whenever Emac_RST bits SRST or HRRTN are set. Because the size of the packet is limited to a minimum of 32 bytes, the last five bits are always zero. See Tables 176 and 177.

Table 176. EMAC Receive Write Pointer Register—Low Byte (EMAC_RWP_L = 0051h)

| Bit | 7 | 6 | 5 | 4 | 3 | 2 | 1 | 0 |
|-------------------|---|---|---|---|---|---|---|---|
| Reset | 0 | 0 | 0 | 0 | 0 | 0 | 0 | 0 |
| CPU Access | R | R | R | R | R | R | R | R |

Note: R = Read Only.

| Bit Position | Value | Description |
|---------------------|-------------|---|
| [7:0] EMAC_RWP_L | 00h– E0h | These bits represent the Low byte of the 2-byte EMAC RxDMA Receive Write Pointer value, {EMAC_RWP_H, EMAC_RWP_L}. Bit 7 is bit 7 of the 16-bit value. Bit 0 is bit 0 (lsb) of the 16-bit value. |



EMAC Receive Write Pointer Register—High Byte

Because of the size of the EMAC's 8KB SRAM, the upper three bits of the EMAC Receive Write Pointer Register are always zero.

Table 177. EMAC Receive Write Pointer Register—High Byte (EMAC_RWP_H = 0052h)

| Bit | 7 | 6 | 5 | 4 | 3 | 2 | 1 | 0 |
|-------------------|---|---|---|---|---|---|---|---|
| Reset | 0 | 0 | 0 | 0 | 0 | 0 | 0 | 0 |
| CPU Access | R | R | R | R | R | R | R | R |

Note: R = Read Only.

| Bit Position | Value | Description |
|---------------------|-------------|---|
| [7:0] EMAC_RWP_H | 00h– 1Fh | These bits represent the High byte of the 2-byte EMAC RxDMA Receive Write Pointer value, {EMAC_RWP_H, EMAC_RWP_L}. Bit 7 is bit 15 (msb) of the 16-bit value. Bit 0 is bit 8 of the 16-bit value. |

EMAC Transmit Read Pointer Register—Low Byte

The Low byte of the Transmit Read Pointer register reports the current TxDMA Transmit Read pointer. This pointer is initialized to EmacTLBP whenever Emac_RST bits SRST or HRRTN are set. Because the size of the packet is limited to a minimum of 32 bytes, the last five bits are always zero. See Table 178.

Table 178. EMAC Transmit Read Pointer Register—Low Byte (EMAC_TRP_L = 0053h)

| Bit | 7 | 6 | 5 | 4 | 3 | 2 | 1 | 0 |
|-------------------|---|---|---|---|---|---|---|---|
| Reset | 0 | 0 | 0 | 0 | 0 | 0 | 0 | 0 |
| CPU Access | R | R | R | R | R | R | R | R |

Note: R = Read Only.

| Bit Position | Value | Description |
|---------------------|-------------|---|
| [7:0] EMAC_TRP_L | 00h– E0h | These bits represent the Low byte of the 2-byte EMAC TxDMA Transmit Read Pointer value, {EMAC_TRP_H, EMAC_TRP_L}. Bit 7 is bit 7 of the 16-bit value. Bit 0 is bit 0 (lsb) of the 16-bit value. |



EMAC Transmit Read Pointer Register—High Byte

Because of the size of the EMAC's 8KB SRAM, the upper three bits of the EMAC Transmit Read Pointer Register are always zero. See Table 179.

Table 179. EMAC Transmit Read Pointer Register—High Byte (EMAC_TRP_H = 0054h)

| Bit | 7 | 6 | 5 | 4 | 3 | 2 | 1 | 0 |
|-------------------|----|----|----|----|----|----|----|----|
| Reset | 0 | 0 | 0 | 0 | 0 | 0 | 0 | 0 |
| CPU Access | RO | RO | RO | RO | RO | RO | RO | RO |

Note: R/W = Read/Write.

| Bit Position | Value | Description |
|---------------------|-------------|---|
| [7:0] EMAC_TRP_H | 00h– 1Fh | These bits represent the High byte of the 2-byte EMAC TxDMA Transmit Read Pointer value, {EMAC_TRP_H, EMAC_TRP_L}. Bit 7 is bit 15 (msb) of the 16-bit value. Bit 0 is bit 8 of the 16-bit value. |

EMAC Receive Blocks Left Register—Low and High Bytes

This register reports the number of buffers left in the Receive EMAC shared memory. The hardware uses this information, along with the Block-Level set in the EMAC_BUFSZ register, to determine when to transmit a pause control frame. Software can use this information to determine when it should request that a pause control frame be transmitted (by setting bit 6 of the EMAC_CFG4 register). For the BlksLeft logic to operate properly, the Receive buffer must contain at least one more packet buffer than the number of packet buffers required for the largest packet. That is, one packet cannot fill the entire Receive buffer. Otherwise, the BlksLeft will be in error. See Tables 180 and 181.



**Table 180. EMAC Receive Blocks Left Register—Low Byte
(EMAC_BLKSLFT_L = 0055h)**

| Bit | 7 | 6 | 5 | 4 | 3 | 2 | 1 | 0 |
|-------------------|---|---|---|---|---|---|---|---|
| Reset | 0 | 0 | 0 | 0 | 0 | 0 | 0 | 0 |
| CPU Access | R | R | R | R | R | R | R | R |

Note: R = Read Only.

| Bit Position | Value | Description |
|-------------------------|-------------|---|
| [7:0] EMAC_BLKSLFT_L | 00h– FFh | These bits represent the Low byte of the 2-byte EMAC Receive Blocks Left value, {EMAC_BLKSLFT_H, EMAC_BLKSLFT_L}. Bit 7 is bit 7 of the 16-bit value. Bit 0 is bit 0 (lsb) of the 16-bit value. |

**Table 181. EMAC Receive Blocks Left Register—High Byte
(EMAC_BLKSLFT_H = 0056h)**

| Bit | 7 | 6 | 5 | 4 | 3 | 2 | 1 | 0 |
|-------------------|---|---|---|---|---|---|---|---|
| Reset | 0 | 0 | 0 | 0 | 0 | 0 | 0 | 0 |
| CPU Access | R | R | R | R | R | R | R | R |

Note: R = Read Only.

| Bit Position | Value | Description |
|-------------------------|-------------|---|
| [7:0] EMAC_BLKSLFT_H | 00h– FFh | These bits represent the High byte of the 2-byte EMAC Receive Blocks Left value, {EMAC_BLKSLFT_H, EMAC_BLKSLFT_L}. Bit 7 is bit 15 (msb) of the 16-bit value. Bit 0 is bit 8 of the 16-bit value. |



EMAC FIFO Data Register—Low and High Bytes

The FIFO Read/Write Test Access Data Register allows writing and reading the FIFO selected by the EMAC_TEST TxRx_SEL bit when the EMAC_TEST register TEST_FIFO bit is set. See Tables 182 and 183.

Table 182. EMAC FIFO Data Register—Low Byte (EMAC_FDATA_L = 0057h)

| Bit | 7 | 6 | 5 | 4 | 3 | 2 | 1 | 0 |
|-------------------|-----|-----|-----|-----|-----|-----|-----|-----|
| Reset | X | X | X | X | X | X | X | X |
| CPU Access | R/W | R/W | R/W | R/W | R/W | R/W | R/W | R/W |

Note: R/W = Read/Write.

| Bit Position | Value | Description |
|-----------------------|-------------|--|
| [7:0] EMAC_FDATA_L | 00h– FFh | These bits represent the Low byte of the 10-bit EMAC FIFO data value, {EMAC_FDATA_H[1:0], EMAC_FDATA_L}. Bit 7 is bit 7 of the 16-bit value. Bit 0 is bit 0 (lsb) of the 10-bit value. |

Table 183. EMAC FIFO Data Register—High Byte (EMAC_FDATA_H = 0058h)

| Bit | 7 | 6 | 5 | 4 | 3 | 2 | 1 | 0 |
|-------------------|---|---|---|---|---|---|-----|-----|
| Reset | 0 | 0 | 0 | 0 | 0 | 0 | X | X |
| CPU Access | R | R | R | R | R | R | R/W | R/W |

Note: R = Read Only; R/W = Read/Write.

| Bit Position | Value | Description |
|-----------------------|-------|--|
| [7:2] | 00h | Reserved. |
| [1:0] EMAC_FDATA_H | 0h–3h | These bits represent the upper two bits of the 10-bit EMAC FIFO data value, {EMAC_FDATA_H[1:0], EMAC_FDATA_L}. Bit 1 is bit 9 (msb) of the 16-bit value. Bit 0 is bit 8 of the 10-bit value. |



EMAC FIFO Flags Register

The FIFO Flags value is set in the EMAC module hardware to *half full*, or 16 bytes. See Table 184.

**Table 184. EMAC FIFO Flags Register
(EMAC_FFLAGS = 0059h)**

| Bit | 7 | 6 | 5 | 4 | 3 | 2 | 1 | 0 |
|-------------------|---|---|---|---|---|---|---|---|
| Reset | 0 | 0 | 1 | 1 | 0 | 0 | 1 | 1 |
| CPU Access | R | R | R | R | R | R | R | R |

Note: R = Read Only.

| Bit Position | Value | Description |
|--------------|-------|---------------------------------|
| 7 | 1 | Transmit FIFO full. |
| TFF | 0 | Transmit FIFO not full. |
| 6 | 0 | Reserved. |
| 5 | 1 | Transmit FIFO almost empty. |
| TFAE | 0 | Transmit FIFO not almost empty. |
| 4 | 1 | Transmit FIFO empty. |
| TFE | 0 | Transmit FIFO not empty. |
| 3 | 1 | Receive FIFO full. |
| RFF | 0 | Receive FIFO not full. |
| 2 | 1 | Receive FIFO almost full. |
| RFAF | 0 | Receive FIFO not almost full. |
| 1 | 1 | Receive FIFO almost empty. |
| RFAE | 0 | Receive FIFO not almost empty. |
| 0 | 1 | Receive FIFO empty. |
| RFE | 0 | Receive FIFO not empty. |

ZiLOG Debug Interface

Introduction

The ZiLOG Debug Interface (ZDI) provides a built-in debugging interface to the CPU. ZDI provides basic in-circuit emulation features including:

- Examining and modifying internal registers
- Examining and modifying memory
- Starting and stopping the user program
- Setting program and data break points
- Single-stepping the user program
- Executing user-supplied instructions
- Debugging the final product with the inclusion of one small connector
- Downloading code into SRAM
- C source-level debugging using ZiLOG Developer Studio II (ZDSII)

The above features are built into the silicon. Control is provided via a two-wire interface that is connected to the ZPAKII emulator. Figure 51 illustrates a typical setup using a target board, ZPAKII, and the host PC running ZiLOG Developer Studio II. Refer to the [ZiLOG website](#) for more information on ZPAKII and ZDSII.

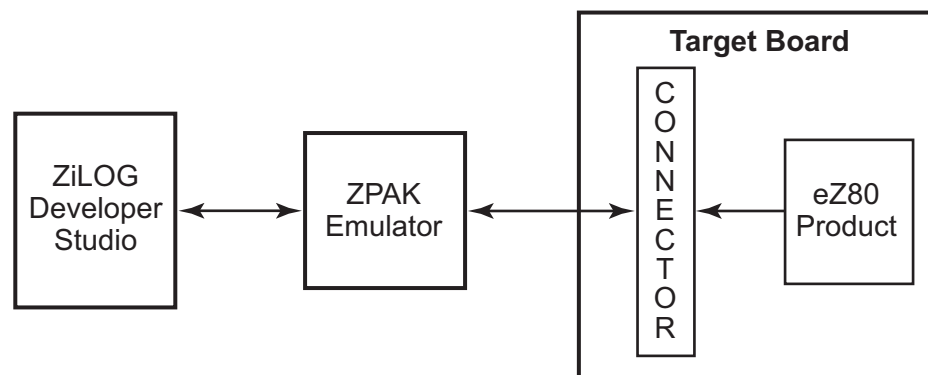

Figure 51. Typical ZDI Debug Setup

ZDI allows reading and writing of most internal registers without disturbing the state of the machine. Reads and Writes to memory can occur as fast as the ZDI

downloads and uploads data, with a maximum frequency of one-half the eZ80F91 system clock frequency, or less. See Table 185 for recommended values.

Table 185. Recommend ZDI Clock vs. System Clock Frequency

| System Clock Frequency | ZDI Clock Frequency |
|------------------------|---------------------|
| 3–10 MHz | 1MHz |
| 8–16 MHz | 2MHz |
| 12–24 MHz | 4MHz |
| 20–50 MHz | 8MHz |

www.DataSheet4U.com

ZDI-Supported Protocol

ZDI supports a bidirectional serial protocol. The protocol defines any device that sends data as the *transmitter* and any receiving device as the *receiver*. The device controlling the transfer is the *master* and the device being controlled is the *slave*. The master always initiates the data transfers and provides the clock for both receive and transmit operations. The ZDI block on the eZ80F91 device is considered a slave in all data transfers.

Figure 52 illustrates the schematic for building a connector on a target board. This connector allows the user to connect directly to the ZPAK emulator using a six-pin header.

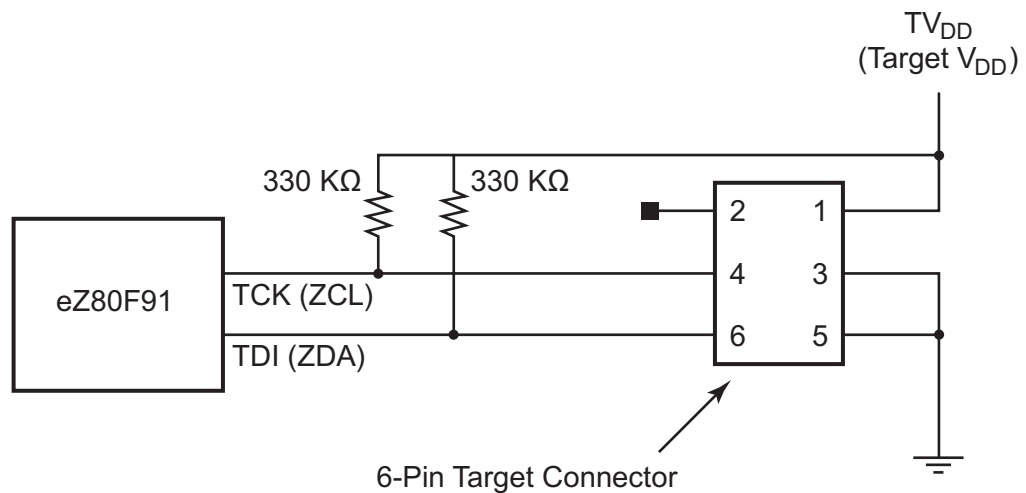

Figure 52. Schematic For Building a Target Board ZPAK Connector

ZDI Clock and Data Conventions

The two pins used for communication with the ZDI block are the ZDI clock pin (ZCL) and the ZDI data pin (ZDA). On the eZ80F91, the ZCL pin is shared with the TCK pin while the ZDA pin is shared with the TDI pin. The ZCL and ZDA pin functions are only available when the On-Chip Instrumentation is disabled and the ZDI is therefore enabled. For general data communication, the data value on the ZDA pin can change only when ZCL is Low (0). The only exception is the ZDI START bit, which is indicated by a High-to-Low transition (falling edge) on the ZDA pin while ZCL is High.

Data is shifted into and out of ZDI, with the most-significant bit (bit 7) of each byte being first in time, and the least-significant bit (bit 0) last in time. All information is passed between the master and the slave in 8-bit (single-byte) units. Each byte is transferred with nine clock cycles: eight to shift the data, and the ninth for internal operations.

ZDI START Condition

All ZDI commands are preceded by the ZDI START signal, which is a High-to-Low transition of ZDA when ZCL is High. The ZDI slave on the eZ80F91 device continually monitors the ZDA and ZCL lines for the START signal and does not respond to any command until this condition is met. The master pulls ZDA Low, with ZCL High, to indicate the beginning of a data transfer with the ZDI block. Figures 53 and 54 illustrate a valid ZDI START signal prior to writing and reading data, respectively. A Low-to-High transition of ZDA while the ZCL is High produces no effect.

Data is shifted in during a Write to the ZDI block on the rising edge of ZCL, as illustrated in Figure 53. Data is shifted out during a Read from the ZDI block on the falling edge of ZCL as illustrated in Figure 54. When an operation is completed, the master stops during the ninth cycle and holds the ZCL signal High.

www.DataSheet4U.com

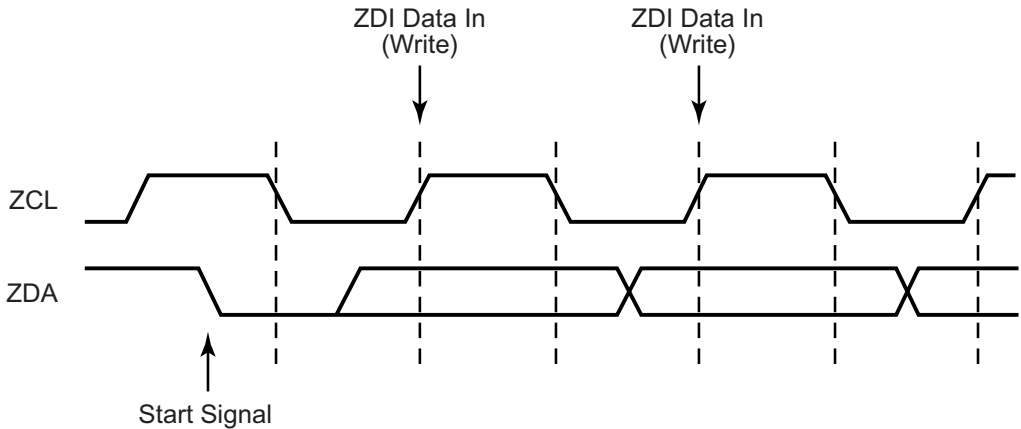

Figure 53. ZDI Write Timing

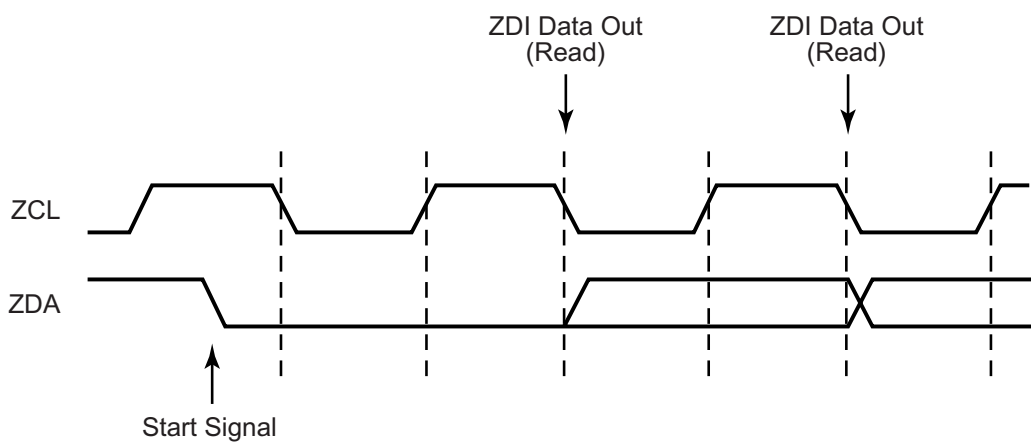

Figure 54. ZDI Read Timing

ZDI Single-Bit Byte Separator

Following each 8-bit ZDI data transfer, a single-bit byte separator is used. To initiate a new ZDI command, the single-bit byte separator must be High (logical 1) to allow for a new ZDI START command to be sent. For all other cases, the single-bit byte separator can be either Low (logical 0) or High (logical 1). When ZDI is configured to allow the CPU to accept external bus requests, the single-bit byte separator should be Low (logical 0) during all ZDI commands. This Low value indicates that ZDI is still operating and is not ready to relinquish the bus. The CPU does not accept the external bus requests until the single-bit byte separator is a High (logi-

cal 1). For more information on accepting bus requests in ZDI DEBUG mode, please see the [Bus Requests During ZDI Debug Mode](#) section on page 293.

ZDI Register Addressing

Following a START signal the ZDI master must output the ZDI register address. All data transfers with the ZDI block use special ZDI registers. The ZDI control registers that reside in the ZDI register address space should not be confused with the eZ80F91 device peripheral registers that reside in the I/O address space.

Many locations in the ZDI control register address space are shared by two registers—one for Read Only access and one for Write Only access. As an example, a Read from ZDI register address 00h returns the eZ80 Product ID Low Byte, while a Write to this same location, 00h, stores the Low byte of one of the address match values used for generating break points.

The format for a ZDI address is seven bits of address, followed by one bit for Read or Write control, and completed by a single-bit byte separator. The ZDI executes a Read or Write operation depending on the state of the R/W bit (0 = Write, 1 = Read). If no new START command is issued at completion of the Read or Write operation, the operation can be repeated. This allows repeated Read or Write operations without having to resend the ZDI command. A START signal must follow to initiate a new ZDI command. Figure 55 illustrates the timing for address Writes to ZDI registers.

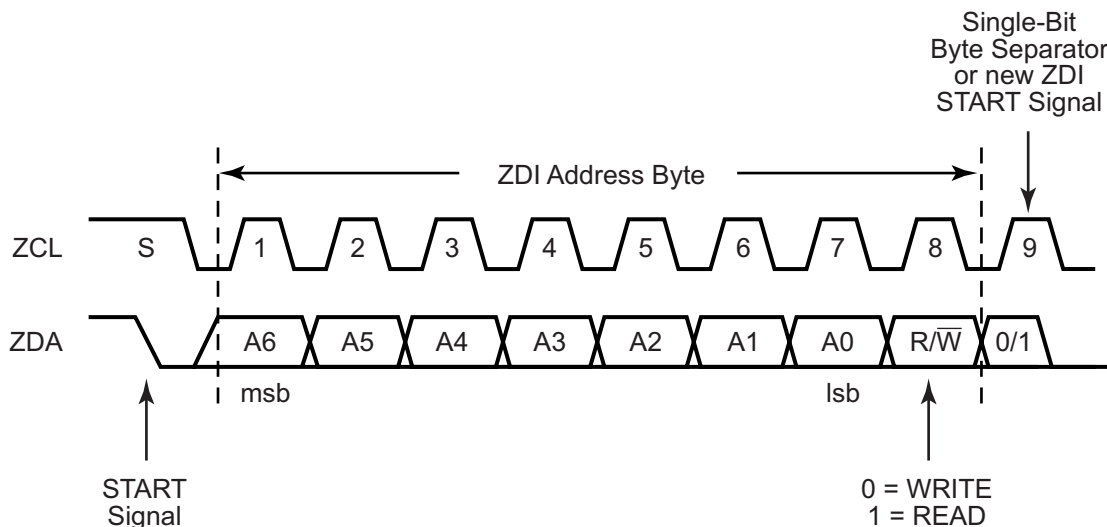

Figure 55. ZDI Address Write Timing

ZDI Write Operations

ZDI Single-Byte Write

For single-byte Write operations, the address and write control bit are first written to the ZDI block. Following the single-bit byte separator, the data is shifted into the ZDI block on the next 8 rising edges of ZCL. The master terminates activity after 8 clock cycles. Figure 56 illustrates the timing for ZDI single-byte Write operations.

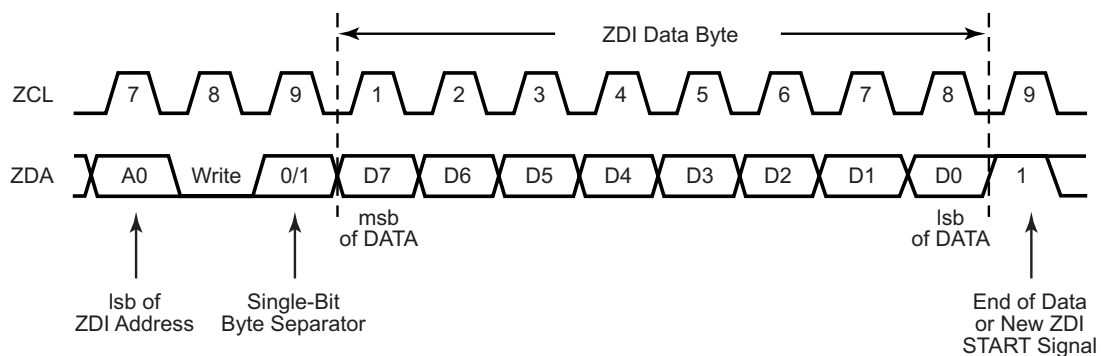

Figure 56. ZDI Single-Byte Data Write Timing

ZDI Block Write

The block Write operation is initiated in the same manner as the single-byte Write operation, but instead of terminating the Write operation after the first data byte is transferred, the ZDI master can continue to transmit additional bytes of data to the ZDI slave on the eZ80F91 device. After the receipt of each byte of data the ZDI register address increments by 1. If the ZDI register address reaches the end of the Write Only ZDI register address space (30h), the address stops incrementing. Figure 57 illustrates the timing for ZDI block Write operations.

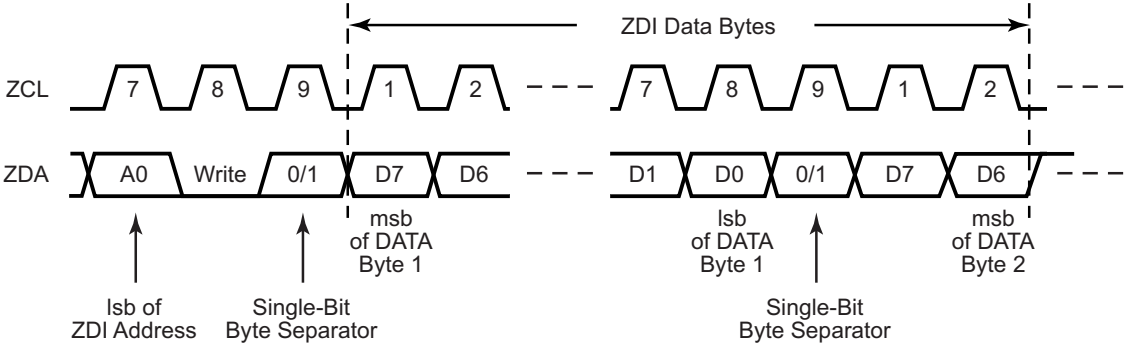

Figure 57. ZDI Block Data Write Timing

ZDI Read Operations

ZDI Single-Byte Read

Single-byte Read operations are initiated in the same manner as single-byte Write operations, with the exception that the R/W bit of the ZDI register address is set to 1. Upon receipt of a slave address with the R/W bit set to 1, the eZ80F91 device's ZDI block loads the selected data into the shifter at the beginning of the first cycle following the single-bit data separator. The most-significant bit (msb) is shifted out first. Figure 58 illustrates the timing for ZDI single-byte Read operations.

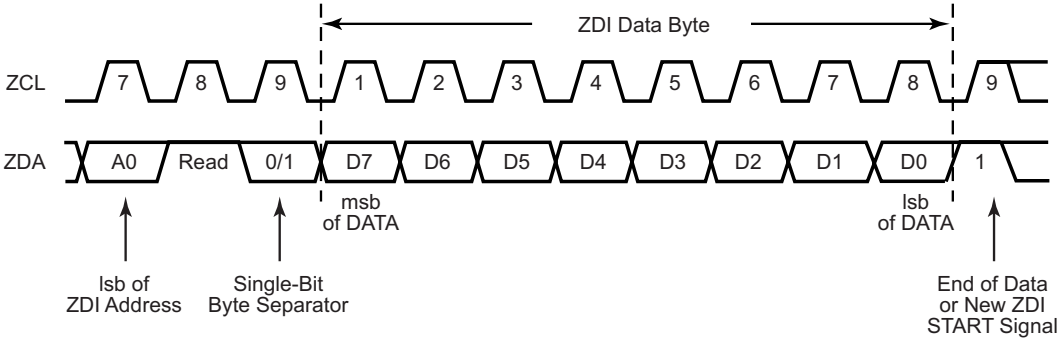

Figure 58. ZDI Single-Byte Data Read Timing

ZDI Block Read

A block Read operation is initiated in the same manner as a single-byte Read; however, the ZDI master continues to clock in the next byte from the ZDI slave as the ZDI slave continues to output data. The ZDI register address counter incre-

ments with each Read. If the ZDI register address reaches the end of the Read Only ZDI register address space (20h), the address stops incrementing. Figure 59 illustrates the ZDI's block Read timing.

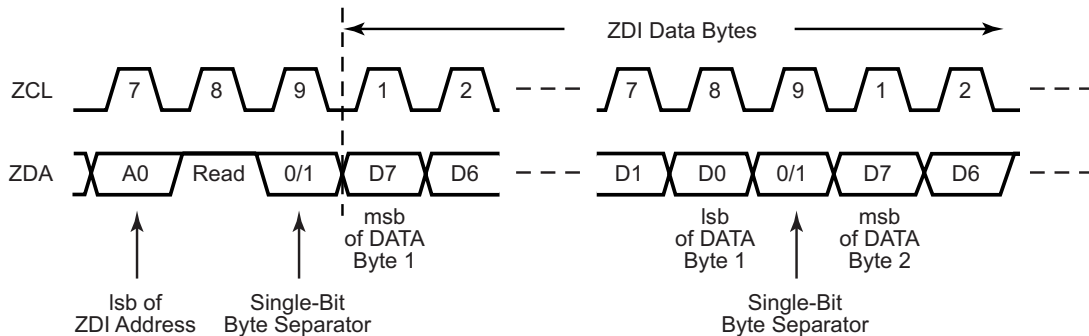

Figure 59. ZDI Block Data Read Timing

Operation of the eZ80F91 Device during ZDI Break Points

If the ZDI forces the CPU to break, only the CPU suspends operation. The system clock continues to operate and drive other peripherals. Those peripherals that can operate autonomously from the CPU can continue to operate, if so enabled. For example, the Watch-Dog Timer and Programmable Reload Timers continue to count during a ZDI break point.

When using the ZDI interface, any Write or Read operations of peripheral registers in the I/O address space produces the same effect as Read or Write operations using the CPU. Because many register Read/Write operations exhibit secondary effects, such as clearing flags or causing operations to commence, the effects of the Read/Write operations during a ZDI break must be taken into consideration.

Bus Requests During ZDI Debug Mode

The ZDI block on the eZ80F91 device allows an external device to take control of the address and data bus while the eZ80F91 device is in DEBUG mode.

ZDI_BUSACK_EN causes ZDI to allow or prevent acknowledgement of bus requests by external peripherals. The bus acknowledge only occurs at the end of the current ZDI operation (indicated by a High during the single-bit byte separator). The default reset condition is for bus acknowledgement to be disabled. To allow bus acknowledgement, the ZDI_BUSACK_EN must be written.

When an external bus request ($\overline{\text{BUSREQ}}$ pin asserted) is detected, ZDI waits until completion of the current operation before responding. ZDI acknowledges the bus request by asserting the bus acknowledge (BUSACK) signal. If the ZDI block is



not currently shifting data, it acknowledges the bus request immediately. ZDI uses the single-bit byte separator of each data word to determine if it is at the end of a ZDI operation. If the bit is a logical 0, ZDI does not assert BUSACK to allow additional data Read or Write operations. If the bit is a logical 1, indicating completion of the ZDI commands, BUSACK is asserted.

Potential Hazards of Enabling Bus Requests During Debug Mode

There are some potential hazards that the user must be aware of when enabling external bus requests during ZDI DEBUG mode. First, when the address and data bus are being used by an external source, ZDI must only access ZDI registers and internal CPU registers to prevent possible bus contention. The bus acknowledge status is reported in the ZDI_BUS_STAT register. The BUSACK output pin also indicates the bus acknowledge state.

A second hazard is that when a bus acknowledge is granted, the ZDI is subject to any wait states that are assigned to the device currently being accessed by the external peripheral. To prevent data errors, ZDI should avoid data transmission while another device is controlling the bus.

Finally, exiting ZDI Debug mode while an external peripheral controls the address and data buses, as indicated by BUSACK assertion, can produce unpredictable results.

ZDI Write Only Registers

Table 186 lists the ZDI Write Only registers. Many of the ZDI Write Only addresses are shared with ZDI Read Only registers.

Table 186. ZDI Write Only Registers

| ZDI Address | ZDI Register Name | ZDI Register Function | Reset Value |
|-------------|-------------------|----------------------------|-------------|
| 00h | ZDI_ADDR0_L | Address Match 0 Low Byte | XXh |
| 01h | ZDI_ADDR0_H | Address Match 0 High Byte | XXh |
| 02h | ZDI_ADDR0_U | Address Match 0 Upper Byte | XXh |
| 04h | ZDI_ADDR1_L | Address Match 1 Low Byte | XXh |
| 05h | ZDI_ADDR1_H | Address Match 1 High Byte | XXh |
| 06h | ZDI_ADDR1_U | Address Match 1 Upper Byte | XXh |
| 08h | ZDI_ADDR2_L | Address Match 2 Low Byte | XXh |
| 09h | ZDI_ADDR2_H | Address Match 2 High Byte | XXh |
| 0Ah | ZDI_ADDR2_U | Address Match 2 Upper Byte | XXh |
| 0Ch | ZDI_ADDR3_L | Address Match 3 Low Byte | XXh |



Table 186. ZDI Write Only Registers (Continued)

| ZDI Address | ZDI Register Name | ZDI Register Function | Reset Value |
|-------------|-------------------|-----------------------------|-------------|
| 0Dh | ZDI_ADDR3_H | Address Match 3 High Byte | XXh |
| 0Eh | ZDI_ADDR3_U | Address Match 4 Upper Byte | XXh |
| 10h | ZDI_BRK_CTL | Break Control Register | 00h |
| 11h | ZDI_MASTER_CTL | Master Control Register | 00h |
| 13h | ZDI_WR_DATA_L | Write Data Low Byte | XXh |
| 14h | ZDI_WR_DATA_H | Write Data High Byte | XXh |
| 15h | ZDI_WR_DATA_U | Write Data Upper Byte | XXh |
| 16h | ZDI_RW_CTL | Read/Write Control Register | 00h |
| 17h | ZDI_BUS_CTL | Bus Control Register | 00h |
| 21h | ZDI_IS4 | Instruction Store 4 | XXh |
| 22h | ZDI_IS3 | Instruction Store 3 | XXh |
| 23h | ZDI_IS2 | Instruction Store 2 | XXh |
| 24h | ZDI_IS1 | Instruction Store 1 | XXh |
| 25h | ZDI_IS0 | Instruction Store 0 | XXh |
| 30h | ZDI_WR_MEM | Write Memory Register | XXh |

ZDI Read Only Registers

Table 187 lists the ZDI Read Only registers. Many of the ZDI Read Only addresses are shared with ZDI Write Only registers.

Table 187. ZDI Read Only Registers

| ZDI Address | ZDI Register Name | ZDI Register Function | Reset Value |
|-------------|-------------------|---|-------------|
| 00h | ZDI_ID_L | eZ80 Product ID Low Byte Register | 08h |
| 01h | ZDI_ID_H | eZ80 Product ID High Byte Register | 00h |
| 02h | ZDI_ID_REV | eZ80 Product ID Revision Register | XXh |
| 03h | ZDI_STAT | Status Register | 00h |
| 10h | ZDI_RD_L | Read Memory Address Low Byte Register | XXh |
| 11h | ZDI_RD_H | Read Memory Address High Byte Register | XXh |
| 12h | ZDI_RD_U | Read Memory Address Upper Byte Register | XXh |



Table 187. ZDI Read Only Registers (Continued)

| ZDI Address | ZDI Register Name | ZDI Register Function | Reset Value |
|-------------|-------------------|------------------------|-------------|
| 17h | ZDI_BUS_STAT | Bus Status Register | 00h |
| 20h | ZDI_RD_MEM | Read Memory Data Value | XXh |

www.DataSheet4U.com

ZDI Register Definitions

ZDI Address Match Registers

The four sets of address match registers are used for setting the addresses for generating break points. When the accompanying BRK_ADDRX bit is set in the ZDI Break Control register to enable the particular address match, the current eZ80F91 address is compared with the 3-byte address set, {ZDI_ADDRx_U, ZDI_ADDRx_H, ZDI_ADDR_x_L}. If the CPU is operating in ADL mode, the address is supplied by ADDR[23:0]. If the CPU is operating in Z80 mode, the address is supplied by {MBASE[7:0], ADDR[15:0]}. If a match is found, ZDI issues a break to the eZ80F91 device placing the CPU in ZDI mode pending further instructions from the ZDI interface block. If the address is not the first op-code fetch, the ZDI break is executed at the end of the instruction in which it is executed. There are four sets of address match registers. They can be used in conjunction with each other to break on branching instructions. See Table 188.

Table 188. ZDI Address Match Registers

ZDI_ADDR0_L = 00h, ZDI_ADDR0_H = 01h, ZDI_ADDR0_U = 02h,
ZDI_ADDR1_L = 04h, ZDI_ADDR1_H = 05h, ZDI_ADDR1_U = 06h,
ZDI_ADDR2_L = 08h, ZDI_ADDR2_H = 09h, ZDI_ADDR2_U = 0Ah,
ZDI_ADDR3_L = 0Ch, ZDI_ADDR3_H = 0Dh, and ZDI_ADDR3_U = 0Eh
in the ZDI Register Write Only Address Space

| Bit | 7 | 6 | 5 | 4 | 3 | 2 | 1 | 0 |
|------------|---|---|---|---|---|---|---|---|
| Reset | X | X | X | X | X | X | X | X |
| CPU Access | W | W | W | W | W | W | W | W |

Note: W = Write Only.

| Bit Position | Value | Description |
|--|-------------|---|
| [7:0] ZDI_ADDRX_L, ZDI_ADDRX_H, or ZDI_ADDRX_U | 00h– FFh | The four sets of ZDI address match registers are used for setting the addresses for generating break points. The 24-bit addresses are supplied by {ZDI_ADDRx_U, ZDI_ADDRx_H, ZDI_ADDRx_L, where x is 0, 1, 2, or 3. |



ZDI Break Control Register

The ZDI Break Control register is used to enable break points. ZDI asserts a break when the CPU instruction address, ADDR[23:0], matches the value in the ZDI Address Match 3 registers, {ZDI_ADDR3_U, ZDI_ADDR3_H, ZDI_ADDR3_L}. BREAKs can only occur on an instruction boundary. If the instruction address is not the beginning of an instruction (that is, for multibyte instructions), then the break occurs at the end of the current instruction. The BRK_NEXT bit is set to 1. The BRK_NEXT bit must be reset to 0 to release the break. See Table 189.

Table 189. ZDI Break Control Register
(ZDI_BRK_CTL = 10h in the ZDI Write Only Register Address Space)

| Bit | 7 | 6 | 5 | 4 | 3 | 2 | 1 | 0 |
|------------|---|---|---|---|---|---|---|---|
| Reset | 0 | 0 | 0 | 0 | 0 | 0 | 0 | 0 |
| CPU Access | W | W | W | W | W | W | W | W |

Note: W = Write Only.

| Bit Position | Value | Description |
|----------------|-------|--|
| 7 BRK_NEXT | 0 | The ZDI break on the next CPU instruction is disabled. Clearing this bit releases the CPU from its current BREAK condition. |
| | 1 | The ZDI break on the next CPU instruction is enabled. The CPU can use multibyte Op Codes and multibyte operands. Break points only occur on the first Op Code in a multibyte Op Code instruction. If the ZCL pin is High and the ZDA pin is Low at the end of RESET, this bit is set to 1 and a break occurs on the first instruction following the RESET. This bit is set automatically during ZDI break on address match. A break can also be forced by writing a 1 to this bit. |
| 6 BRK_ADDR3 | 0 | The ZDI break, upon matching break address 3, is disabled. |
| | 1 | The ZDI break, upon matching break address 3, is enabled. |
| 5 BRK_ADDR2 | 0 | The ZDI break, upon matching break address 2, is disabled. |
| | 1 | The ZDI break, upon matching break address 2, is enabled. |



| Bit Position | Value | Description |
|------------------|-------|---|
| 4 BRK_ADDR1 | 0 | The ZDI break, upon matching break address 1, is disabled. |
| | 1 | The ZDI break, upon matching break address 1, is enabled. |
| 3 BRK_ADDR0 | 0 | The ZDI break, upon matching break address 0, is disabled. |
| | 1 | The ZDI break, upon matching break address 0, is enabled. |
| 2 IGN_LOW_1 | 0 | The <i>Ignore the Low Byte</i> function of the ZDI Address Match 1 registers is disabled. If BRK_ADDR1 is set to 1, ZDI initiates a break when the entire 24-bit address, ADDR[23:0], matches the 3-byte value {ZDI_ADDR1_U, ZDI_ADDR1_H, ZDI_ADDR1_L}. |
| | 1 | The <i>Ignore the Low Byte</i> function of the ZDI Address Match 1 registers is enabled. If BRK_ADDR1 is set to 1, ZDI initiates a break when only the upper 2 bytes of the 24-bit address, ADDR[23:8], match the 2-byte value {ZDI_ADDR1_U, ZDI_ADDR1_H}. As a result, a break can occur anywhere within a 256-byte page. |
| 1 IGN_LOW_0 | 0 | The <i>Ignore the Low Byte</i> function of the ZDI Address Match 0 registers is disabled. If BRK_ADDR0 is set to 1, ZDI initiates a break when the entire 24-bit address, ADDR[23:0], matches the 3-byte value {ZDI_ADDR0_U, ZDI_ADDR0_H, ZDI_ADDR0_L}. |
| | 1 | The <i>Ignore the Low Byte</i> function of the ZDI Address Match 0 registers is enabled. If the BRK_ADDR1 is set to 0, ZDI initiates a break when only the upper 2 bytes of the 24-bit address, ADDR[23:8], match the 2 bytes value {ZDI_ADDR0_U, ZDI_ADDR0_H}. As a result, a break can occur anywhere within a 256-byte page. |
| 0 SINGLE_STEP | 0 | ZDI SINGLE STEP mode is disabled. |
| | 1 | ZDI SINGLE STEP mode is enabled. ZDI asserts a break following execution of each instruction. |



ZDI Master Control Register

The ZDI Master Control register provides control of the eZ80F91 device. It is capable of forcing a RESET and waking up the eZ80F91 from the low-power modes (HALT or SLEEP). See Table 190.

**Table 190. ZDI Master Control Register
(ZDI_MASTER_CTL = 11h in ZDI Register Write Address Spaces)**

| Bit | 7 | 6 | 5 | 4 | 3 | 2 | 1 | 0 |
|-------------------|---|---|---|---|---|---|---|---|
| Reset | 0 | 0 | 0 | 0 | 0 | 0 | 0 | 0 |
| CPU Access | W | W | W | W | W | W | W | W |

Note: W = Write Only.

| Bit Position | Value | Description |
|--------------|---------|---|
| 7 | 0 | No action. |
| ZDI_RESET | 1 | Initiate a RESET of the eZ80F91. This bit is automatically cleared at the end of the RESET event. |
| [6:0] | 0000000 | Reserved. |



ZDI Write Data Registers

These three registers are used in the ZDI Write Only register address space to store the data that is written when a Write instruction is sent to the ZDI Read/Write Control register (ZDI_RW_CTL). The ZDI Read/Write Control register is located at ZDI address 16h immediately following the ZDI Write Data registers. As a result, the ZDI Master is allowed to write the data to {ZDI_WR_U, ZDI_WR_H, ZDI_WR_L} and the Write command in one data transfer operation. See Table 191.

Table 191. ZDI Write Data Registers
(ZDI_WR_U = 13h, ZDI_WR_H = 14h, and ZDI_WR_L = 15h
in the ZDI Register Write Only Address Space)

| Bit | 7 | 6 | 5 | 4 | 3 | 2 | 1 | 0 |
|-------------------|---|---|---|---|---|---|---|---|
| Reset | X | X | X | X | X | X | X | X |
| CPU Access | W | W | W | W | W | W | W | W |

Note: X = Undefined; W = Write.

| Bit Position | Value | Description |
|---|-------------|---|
| [7:0] ZDI_WR_L, ZDI_WR_H, or ZDI_WR_L | 00h– FFh | These registers contain the data that is written during execution of a Write operation defined by the ZDI_RW_CTL register. The 24-bit data value is stored as {ZDI_WR_U, ZDI_WR_H, ZDI_WR_L}. If less than 24 bits of data are required to complete the required operation, the data is taken from the least-significant byte(s). |

ZDI Read/Write Control Register

The ZDI Read/Write Control register is used in the ZDI Write Only Register address to read data from, write data to, and manipulate the CPU's registers or memory locations. When this register is written, the eZ80F91 device immediately performs the operation corresponding to the data value written as described in Table 192. When a Read operation is executed via this register, the requested data values are placed in the ZDI Read Data registers {ZDI_RD_U, ZDI_RD_H, ZDI_RD_L}. When a Write operation is executed via this register, the Write data is taken from the ZDI Write Data registers {ZDI_WR_U, ZDI_WR_H, ZDI_WR_L}. See Table 192. Refer to the eZ80 CPU User Manual (UM0077) on zilog.com for information regarding the CPU registers.



Table 192. ZDI Read/Write Control Register Functions*
(ZDI_RW_CTL = 16h in the ZDI Register Write Only Address Space)

| Hex Value | Command | Hex Value | Command |
|-----------|--|-----------|---|
| 00 | Read {MBase, A, F} ZDI_RD_U ← MBase ZDI_RD_H ← F ZDI_RD_L ← A | 80 | Write AF MBase ← ZDI_WR_U F ← ZDI_WR_H A ← ZDI_WR_L |
| 01 | Read BC ZDI_RD_U ← BCU ZDI_RD_H ← B ZDI_RD_L ← C | 81 | Write BC BCU ← ZDI_WR_U B ← ZDI_WR_H C ← ZDI_WR_L |
| 02 | Read DE ZDI_RD_U ← DEU ZDI_RD_H ← D ZDI_RD_L ← E | 82 | Write DE DEU ← ZDI_WR_U D ← ZDI_WR_H E ← ZDI_WR_L |
| 03 | Read HL ZDI_RD_U ← HLU ZDI_RD_H ← H ZDI_RD_L ← L | 83 | Write HL HLU ← ZDI_WR_U H ← ZDI_WR_H L ← ZDI_WR_L |
| 04 | Read IX ZDI_RD_U ← IXU ZDI_RD_H ← IXH ZDI_RD_L ← IXL | 84 | Write IX IXU ← ZDI_WR_U IXH ← ZDI_WR_H IXL ← ZDI_WR_L |
| 05 | Read IY ZDI_RD_U ← IYU ZDI_RD_H ← IYH ZDI_RD_L ← IYL | 85 | Write IY IYU ← ZDI_WR_U IYH ← ZDI_WR_H IYL ← ZDI_WR_L |
| 06 | Read SP In ADL mode, SP = SPL. In Z80 mode, SP = SPS. | 86 | Write SP In ADL mode, SP = SPL. In Z80 mode, SP = SPS. |
| 07 | Read PC ZDI_RD_U ← PC[23:16] ZDI_RD_H ← PC[15:8] ZDI_RD_L ← PC[7:0] | 87 | Write PC PC[23:16] ← ZDI_WR_U PC[15:8] ← ZDI_WR_H PC[7:0] ← ZDI_WR_L |
| 08 | Set ADL ADL ← 1 | 88 | Reserved |

Note: *The CPU's alternate register set (A', F', B', C', D', E', HL') cannot be read directly. The ZDI programmer must execute the exchange instruction (EXX) to gain access to the alternate CPU register set.



Table 192. ZDI Read/Write Control Register Functions*
(ZDI_RW_CTL = 16h in the ZDI Register Write Only Address Space) (Continued)

| Hex Value | Command | Hex Value | Command |
|-----------|--|-----------|--|
| 09 | Reset ADL ADL ← 0 | 89 | Reserved |
| 0A | Exchange CPU register sets AF ← AF' BC ← BC' DE ← DE' HL ← HL' | 8A | Reserved |
| 0B | Read memory from current PC value, increment PC | 8B | Write memory from current PC value, increment PC |

Note: *The CPU's alternate register set (A', F', B', C', D', E', HL') cannot be read directly. The ZDI programmer must execute the exchange instruction (EXX) to gain access to the alternate CPU register set.

ZDI Bus Control Register

The ZDI Bus Control register controls bus requests during DEBUG mode. It enables or disables bus acknowledge in ZDI DEBUG mode and allows ZDI to force assertion of the BUSACK signal. This register should only be written during ZDI Debug mode (that is, following a break). See Table 193.

Table 193. ZDI Bus Control Register
(ZDI_BUS_CTL = 17h in the ZDI Register Write Only Address Space)

| Bit | 7 | 6 | 5 | 4 | 3 | 2 | 1 | 0 |
|-------------------|---|---|---|---|---|---|---|---|
| Reset | 0 | 0 | 0 | 0 | 0 | 0 | 0 | 0 |
| CPU Access | W | W | W | W | W | W | W | W |

Note: W = Write Only.

| Bit Position | Value | Description |
|-------------------|-------|--|
| 7 ZDI_BUSAK_EN | 0 | Bus requests by external peripherals using the <u>BUSREQ</u> pin are ignored. The bus acknowledge signal, BUSACK, is not asserted in response to any bus requests. |
| | 1 | Bus requests by external peripherals using the <u>BUSREQ</u> pin are accepted. A bus acknowledge occurs at the end of the current ZDI operation. <u>The bus acknowledge</u> is indicated by asserting the BUSACK pin in response to a bus request. |

| Bit Position | Value | Description |
|----------------|--------|--|
| 6 ZDI_BUSAK | 0 | Deassert the bus acknowledge pin (BUSACK) to return control of the address and data buses back to ZDI. |
| | 1 | Assert the bus acknowledge pin (BUSACK) to pass control of the address and data buses to an external peripheral. |
| [5:0] | 000000 | Reserved. |

Instruction Store 4:0 Registers

The ZDI Instruction Store registers are located in the ZDI Register Write Only address space. They can be written with instruction data for direct execution by the CPU. When the ZDI_IS0 register is written, the eZ80F91 device exits the ZDI break state and executes a single instruction. The Op Codes and operands for the instruction come from these Instruction Store registers. The Instruction Store Register 0 is the first byte fetched, followed by Instruction Store registers 1, 2, 3, and 4, as necessary. Only the bytes the CPU requires to execute the instruction must be stored in these registers. Some CPU instructions, when combined with the MEMORY mode suffixes (.SIS, .SIL, .LIS, or .LIL), require 6 bytes to operate. These 6-byte instructions cannot be executed directly using the ZDI Instruction Store registers. See Table 194.

- **Note:** The **Instruction Store 0** register is located at a higher ZDI address than the other **Instruction Store** registers. This feature allows the use of the ZDI auto-address increment function to load and execute a multibyte instruction with a single data stream from the ZDI master. Execution of the instruction commences with writing the final byte to ZDI_IS0.



Table 194. Instruction Store 4:0 Registers
(ZDI_IS4 = 21h, ZDI_IS3 = 22h, ZDI_IS2 = 23h, ZDI_IS1 = 24h, and ZDI_IS0 = 25h
in the ZDI Register Write Only Address Space)

| Bit | 7 | 6 | 5 | 4 | 3 | 2 | 1 | 0 |
|-------------------|---|---|---|---|---|---|---|---|
| Reset | X | X | X | X | X | X | X | X |
| CPU Access | W | W | W | W | W | W | W | W |

Note: X = Undefined; W = Write.

| Bit Position | Value | Description |
|--|-------------|---|
| [7:0] ZDI_IS4, ZDI_IS3, ZDI_IS2, ZDI_IS1, or ZDI_IS0 | 00h– FFh | These registers contain the Op Codes and operands for immediate execution by the CPU following a Write to ZDI_IS0. The ZDI_IS0 register contains the first Op Code of the instruction. The remaining ZDI_ISx registers contain any additional Op Codes or operand dates required for execution of the required instruction. |

ZDI Write Memory Register

A Write to the ZDI Write Memory register causes the eZ80F91 device to write the 8-bit data to the memory location specified by the current address in the Program Counter. In Z80 MEMORY mode, this address is {MBASE, PC[15:0]}. In ADL MEMORY mode, this address is PC[23:0]. The Program Counter, PC, increments after each data Write. However, the ZDI register address does not increment automatically when this register is accessed. As a result, the ZDI master is allowed to write any number of data bytes by writing to this address one time followed by any number of data bytes. See Table 195.



Table 195. ZDI Write Memory Register
(ZDI_WR_MEM = 30h in the ZDI Register Write Only Address Space)

| Bit | 7 | 6 | 5 | 4 | 3 | 2 | 1 | 0 |
|-------------------|---|---|---|---|---|---|---|---|
| Reset | X | X | X | X | X | X | X | X |
| CPU Access | W | W | W | W | W | W | W | W |

Note: X = Undefined; W = Write.

| Bit Position | Value | Description |
|---------------------|-------------|--|
| [7:0] ZDI_WR_MEM | 00h– FFh | The 8-bit data that is transferred to the ZDI slave following a Write to this address is written to the address indicated by the current Program Counter. The Program Counter is incremented following each 8 bits of data. In Z80 MEMORY mode, ({MBASE, PC[15:0]}) ← 8 bits of transferred data. In ADL MEMORY mode, (PC[23:0]) ← 8-bits of transferred data. |

eZ80 Product ID Low and High Byte Registers

The eZ80 Product ID Low and High Byte registers combine to provide a means for an external device to determine the particular eZ80[®] product being addressed. See Tables 196 and 197.

Table 196. eZ80 Product ID Low Byte Register
(ZDI_ID_L = 00h in the ZDI Register Read Only Address Space,
ZDI_ID_L = 0000h in the I/O Register Address Space)

| Bit | 7 | 6 | 5 | 4 | 3 | 2 | 1 | 0 |
|-------------------|---|---|---|---|---|---|---|---|
| Reset | 0 | 0 | 0 | 0 | 1 | 0 | 0 | 0 |
| CPU Access | R | R | R | R | R | R | R | R |

Note: R = Read Only.

| Bit Position | Value | Description |
|-------------------|-------|--|
| [7:0] ZDI_ID_L | 08h | {ZDI_ID_H, ZDI_ID_L} = {00h, 08h} indicates the eZ80F91 product. |



Table 197. eZ80 Product ID High Byte Register
(ZDI_ID_H = 01h in the ZDI Register Read Only Address Space,
ZDI_ID_H = 0001h in the I/O Register Address Space)

| Bit | 7 | 6 | 5 | 4 | 3 | 2 | 1 | 0 |
|-------------------|---|---|---|---|---|---|---|---|
| Reset | 0 | 0 | 0 | 0 | 0 | 0 | 0 | 0 |
| CPU Access | R | R | R | R | R | R | R | R |

Note: R = Read Only.

| Bit Position | Value | Description |
|-------------------|-------|---|
| [7:0] ZDI_ID_H | 00h | {ZDI_ID_H, ZDI_ID_L} = {00h, 08h} indicates the eZ80F91 device. |

eZ80 Product ID Revision Register

The eZ80 Product ID Revision register identifies the current revision of the eZ80F91 product. See Table 198. The revision register use the same numbering used in the mask revision of the die. The first nibble (most-significant) corresponds to a full mask revision, while the second nibble refers to a partial mask revision.

Table 198. eZ80 Product ID Revision Register
(ZDI_ID_REV = 02h in the ZDI Register Read Only Address Space,
ZDI_ID_REV = 0002h in the I/O Register Address Space)

| Bit | 7 | 6 | 5 | 4 | 3 | 2 | 1 | 0 |
|-------------------|---|---|---|---|---|---|---|---|
| Reset | X | X | X | X | X | X | X | X |
| CPU Access | R | R | R | R | R | R | R | R |

Note: X = Undetermined; R = Read Only.

| Bit Position | Value | Description |
|---------------------|-------------|---|
| [7:0] ZDI_ID_REV | 00h– FFh | Identifies the current revision of the eZ80F91 product. |



ZDI Status Register

The ZDI Status register provides current information on the eZ80F91 device and the CPU. See Table 199.

Table 199. ZDI Status Register
(ZDI_STAT = 03h in the ZDI Register Read Only Address Space)

| Bit | 7 | 6 | 5 | 4 | 3 | 2 | 1 | 0 |
|-------------------|---|---|---|---|---|---|---|---|
| Reset | 0 | 0 | 0 | 0 | 0 | 0 | 0 | 0 |
| CPU Access | R | R | R | R | R | R | R | R |

Note: R = Read Only.

| Bit Position | Value | Description |
|-------------------|-------|--|
| 7 ZDI_ACTIVE | 0 | The CPU is not functioning in ZDI mode. |
| | 1 | The CPU is currently functioning in ZDI mode. |
| 6 | 0 | Reserved. |
| 5 halt_SLP | 0 | The CPU is not currently in HALT or SLEEP mode. |
| | 1 | The CPU is currently in HALT or SLEEP mode. |
| 4 ADL | 0 | The CPU is operating in Z80 MEMORY mode. (ADL bit = 0) |
| | 1 | The CPU is operating in ADL MEMORY mode. (ADL bit = 1) |
| 3 MADL | 0 | The CPU's Mixed-Memory mode (MADL) bit is reset to 0. |
| | 1 | The CPU's Mixed-Memory mode (MADL) bit is set to 1. |
| 2 IEF1 | 0 | The CPU's Interrupt Enable Flag 1 is reset to 0. Maskable interrupts are disabled. |
| | 1 | The CPU's Interrupt Enable Flag 1 is set to 1. Maskable interrupts are enabled. |
| [1:0] RESERVED | 00 | Reserved. |



ZDI Read Register Low, High, and Upper

The ZDI register Read Only address space offers Low, High, and Upper functions, which contain the value read by a Read operation from the ZDI Read/Write Control register (ZDI_RW_CTL). This data is valid only while in ZDI BREAK mode and only if the instruction is read by a request from the ZDI Read/Write Control register. See Table 200.

Table 200. ZDI Read Register Low, High and Upper (ZDI_RD_L = 10h, ZDI_RD_H = 11h, and ZDI_RD_U = 12h in the ZDI Register Read Only Address Space)

| Bit | 7 | 6 | 5 | 4 | 3 | 2 | 1 | 0 |
|-------------------|---|---|---|---|---|---|---|---|
| Reset | 0 | 0 | 0 | 0 | 0 | 0 | 0 | 0 |
| CPU Access | R | R | R | R | R | R | R | R |

Note: R = Read Only.

| Bit Position | Value | Description |
|---|-------------|---|
| [7:0] ZDI_RD_L, ZDI_RD_H, or ZDI_RD_U | 00h– FFh | Values read from the memory location as requested by the ZDI Read Control register during a ZDI Read operation. The 24-bit value is supplied by {ZDI_RD_U, ZDI_RD_H, ZDI_RD_L}. |



ZDI Bus Status Register

The ZDI Bus Status register monitors BUSACKs during DEBUG mode. See Table 201.

**Table 201. ZDI Bus Control Register
(ZDI_BUS_STAT = 17h in the ZDI Register Read Only Address Space)**

| Bit | 7 | 6 | 5 | 4 | 3 | 2 | 1 | 0 |
|-------------------|---|---|---|---|---|---|---|---|
| Reset | 0 | 0 | 0 | 0 | 0 | 0 | 0 | 0 |
| CPU Access | R | R | R | R | R | R | R | R |

Note: R = Read Only.

| Bit Position | Value | Description |
|--------------------|--------|---|
| 7 ZDI_BUSACK_EN | 0 | <u>Bus requests</u> by external peripherals using the BUSREQ pin are ignored. The bus acknowledge signal, BUSACK, is not asserted. |
| | 1 | <u>Bus requests</u> by external peripherals using the BUSREQ pin are accepted. A bus acknowledge occurs at the end of the current ZDI operation. The <u>bus acknowledge</u> is indicated by asserting the BUSACK pin. |
| 6 ZDI_BUS_STAT | 0 | Address and data buses are not relinquished to an <u>external peripheral</u> . bus acknowledge is deasserted (BUSACK pin is High). |
| | 1 | Address and data buses are relinquished <u>to an external peripheral</u> . bus acknowledge is asserted (BUSACK pin is Low). |
| [5:0] | 000000 | Reserved. |

ZDI Read Memory Register

When a Read is executed from the ZDI Read Memory register, the eZ80F91 device fetches the data from the memory address currently pointed to by the Program Counter, PC; the Program Counter is then incremented. In Z80 MEMORY mode, the memory address is {MBASE, PC[15:0]}. In ADL MEMORY mode, the memory address is PC[23:0]. Refer to the eZ80 CPU User Manual (UM0077), available on zillog.com, for more information regarding Z80 and ADL MEMORY modes. The Program Counter, PC, increments after each data Read. However, the ZDI register address does not increment automatically when this register is accessed. As a result, the ZDI master can read any number of data bytes out of memory via the ZDI Read Memory register. See Table 202.



**Table 202. ZDI Read Memory Register
(ZDI_RD_MEM = 20h in the ZDI Register Read Only Address Space)**

| Bit | 7 | 6 | 5 | 4 | 3 | 2 | 1 | 0 |
|-------------------|---|---|---|---|---|---|---|---|
| Reset | 0 | 0 | 0 | 0 | 0 | 0 | 0 | 0 |
| CPU Access | R | R | R | R | R | R | R | R |

Note: R = Read Only.

| Bit Position | Value | Description |
|---------------------|-------------|--|
| [7:0] ZDI_RD_MEM | 00h– FFh | 8-bit data Read from the memory address indicated by the CPU's Program Counter. In Z80 MEMORY mode, 8-bit data is transferred out from address {MBASE, PC[15:0]}. In ADL Memory mode, 8-bit data is transferred out from address PC[23:0]. |

On-Chip Instrumentation

Introduction to On-Chip Instrumentation

On-Chip Instrumentation¹ (OCI™) for the eZ80® CPU core enables powerful debugging features. The OCI provides run control, memory and register visibility, complex break points, and trace history features.

The OCI employs all of the functions of the ZiLOG Debug Interface (ZDI) as described in the ZDI section. It also adds the following debug features:

- Control via a 4-pin JTAG port that conforms to IEEE Standard 1149.1 (Test Access Port and Boundary Scan Architecture)
- Complex break point trigger functions
- Break point enhancements, such as the ability to:
 - Define two break point addresses that form a range
 - Break on masked data values
 - Start or stop trace
 - Assert a trigger output signal
- Trace history buffer
- Software break point instruction

There are four sections to the OCI:

- JTAG interface
- ZDI debug control
- Trace buffer memory
- Complex triggers

This document contains information to activate the OCI for JTAG boundary scan register operations. For additional information regarding OCI features, or to order OCI debug tools, please contact:

First Silicon Solutions, Inc.
5440 SW Westgate Drive, Suite 240
Portland, OR 97221
Phone: (503) 292-6730
Fax: (503) 292-5840
www.fs2.com

1. On-Chip Instrumentation and OCI are trademarks of First Silicon Solutions, Inc.



OCI Activation

OCI features clock initialization circuitry so that external debug hardware can be detected during power-up. The external debugger must drive the OCI clock pin (TCK) Low at least two system clock cycles prior to the end of the RESET to activate the OCI block. If TCK is High at the end of the RESET, the OCI block shuts down so that it does not draw power in normal product operation. When the OCI is shut down, ZDI is enabled directly and can be accessed via the clock (TCK) and data (TDI) pins. See the [ZiLOG Debug Interface](#) section on page 286 for more information on ZDI.

OCI Interface

There are six dedicated pins on the eZ80F91 for the OCI interface. Four pins—TCK, TMS, TDI, and TDO—are required for IEEE Standard 1149.1-compliant JTAG ports. A fifth pin, TRSTn, is optional for IEEE 1149.1 and utilized by the eZ80F91 device. The TRIGOUT pin provides additional testability features. These six OCI pins are described in Table 203.

Table 203. OCI Pins

| Symbol | Name | Type | Description |
|--------|------------------|---------------------|--|
| TCK | Clock. | Input | Asynchronous to the primary eZ80F91 system clock. The TCK period must be at least twice the system clock period. During RESET, this pin is sampled to select either OCI or ZDI DEBUG modes. If Low during RESET, the OCI is enabled. If High during RESET, the OCI is powered down and ZDI DEBUG mode is enabled. When ZDI DEBUG mode is active, this pin is the ZDI clock. On-chip pull-up ensures a default value of 1 (High). |
| TRSTn | TAP Reset | Input | Active Low asynchronous reset for the Test Access Port state register. On-chip pull-up ensures a default value of 1 (High). |
| TMS | Test Mode Select | Input | This serial test mode input controls JTAG mode selection. On-chip pull-up ensures a default value of 1 (High). The TMS signal is sampled on the rising edge of the TCK signal. |
| TDI | Data In | Input (OCI enabled) | Serial test data input. This pin is input-only when the OCI is enabled. The input data is sampled on the rising edge of the TCK signal. |
| | | I/O (OCI disabled) | When the OCI is disabled, this pin functions as the ZDA (ZDI Data) I/O pin. NORMAL mode, following RESET, configures TDI as an input. |

Table 203. OCI Pins (Continued)

| Symbol | Name | Type | Description |
|---------|----------------|--------|--|
| TDO | Data Out | Output | The output data changes on the falling edge of the TCK signal. |
| TRIGOUT | Trigger Output | Output | Generates an active High trigger pulse when valid OCI trigger events occur. Output is tristate when no data is being driven out. |

JTAG Boundary Scan

Introduction

This section describes coverage, implementation, and usage of the eZ80F91 boundary scan register based on the Joint Test Action Group (JTAG) standard. A working knowledge of the IEEE 1149.1 specification, particularly Clause 11, is assumed.

Pin Coverage

All pins are included in the boundary scan chain, except for the following:

- TCK
- TMS
- TDI
- TDO
- TRSTN
- V_{DD}
- V_{SS}
- PLL_ V_{DD}
- PLL_ V_{SS}
- RTC_ V_{DD}
- X_{IN}
- X_{OUT}
- RTC_ X_{IN}
- RTC_ X_{OUT}
- LOOP_FILT



Boundary Scan Cell Functionality

The boundary scan cells implemented are analogous to cell BC_1, defined in the Standard VHDL Package STD_1149_1_2001.

All boundary scan cells are of the type *control-and-observe*; they provide both controllability and observability for the pins to which they are connected. For tristate outputs and bidirectional pins, this type includes controllability and observability of output enables.

Chain Sequence and Length

When enabled to shift data, the boundary scan shift register is connected to TDI at the input line for TRIGOUT and to TDO at PD0. The shift register is arranged so that data is shifted via the pins starting to the left of the OCI interface pins and proceeding clockwise around the chip. If a pin features multiple scannable bits (e.g., bidirectional pins or tristate output pins), the data is shifted first into the input signal, then the output, then the output enable (OEN).

The boundary scan register is 213 bits wide. Table 204 shows the ordering of bits in the shift register, numbering them in clockwise order.

Table 204. Pin to Boundary Scan Cell Mapping

| Pin | Direction | Scan Cell # | Pin | Direction | Scan Cell # |
|--------------------------------|-----------|-------------|----------|-----------|-------------|
| TRIGOUT | Input | 0 | MII_TxD2 | Output | 107 |
| TRIGOUT | Output | 1 | MII_TxD3 | Output | 108 |
| TRIGOUT | OEN | 2 | MII_COL | Input | 109 |
| $\overline{\text{HALT_SLP}}$ | Output | 3 | MII_CRS | Input | 110 |
| BUSACK | Output | 4 | PA7 | Input | 111 |
| BUSREQ | Input | 5 | PA7 | Output | 112 |
| $\overline{\text{NMI}}$ | Input | 6 | PA7 | OEN | 113 |
| $\overline{\text{RESET}}$ | Input | 7 | PA6 | Input | 114 |
| $\overline{\text{RESET_OUT}}$ | Output | 8 | PA6 | Output | 115 |
| $\overline{\text{WAIT}}$ | Input | 9 | PA6 | OEN | 116 |
| $\overline{\text{INSTRD}}$ | Output | 10 | PA5 | Input | 117 |

Notes:

1. The address bits 0–7, 8–15, and 16–23 each share a single output enable. In this table, the output enables are shown to be associated with the least-significant bit that they control.
2. Direction on the data bus is controlled by a single output enable. It is shown in this table as being associated with D[0].
3. MREQ, IORQ, $\overline{\text{INSTRDN}}$, $\overline{\text{RD}}$, and $\overline{\text{WR}}$ share an output enable; it is associated in this table with $\overline{\text{WR}}$.



Table 204. Pin to Boundary Scan Cell Mapping (Continued)

| Pin | Direction | Scan Cell # | Pin | Direction | Scan Cell # |
|--------------------------|-----------|-------------|-----|-----------|-------------|
| $\overline{\text{WR}}$ | Output | 11 | PA5 | Output | 118 |
| $\overline{\text{WR}}$ | OEN | 12 | PA5 | OEN | 119 |
| $\overline{\text{RD}}$ | Output | 13 | PA4 | Input | 120 |
| $\overline{\text{MREQ}}$ | Input | 14 | PA4 | Output | 121 |
| $\overline{\text{MREQ}}$ | Output | 15 | PA4 | OEN | 122 |
| $\overline{\text{IORQ}}$ | Input | 16 | PA3 | Input | 123 |
| $\overline{\text{IORQ}}$ | Output | 17 | PA3 | Output | 124 |
| D7 | Input | 18 | PA3 | OEN | 125 |
| D7 | Output | 19 | PA2 | Input | 126 |
| D6 | Input | 20 | PA2 | Output | 127 |
| D6 | Output | 21 | PA2 | OEN | 128 |
| D5 | Input | 22 | PA1 | Input | 129 |
| D5 | Output | 23 | PA1 | Output | 130 |
| D4 | Input | 24 | PA1 | OEN | 131 |
| D4 | Output | 25 | PA0 | Input | 132 |
| D3 | Input | 26 | PA0 | Output | 133 |
| D3 | Output | 27 | PA0 | OEN | 134 |
| D2 | Input | 28 | PHI | Output | 135 |
| D2 | Output | 29 | PHI | OEN | 136 |
| D1 | Input | 30 | SCL | Input | 137 |
| D1 | Output | 31 | SCL | Output | 138 |
| D0 | Input | 32 | SDA | Input | 139 |
| D0 | Output | 33 | SDA | Output | 140 |
| D0 | OEN | 34 | PB7 | Input | 141 |
| $\overline{\text{CS3}}$ | Output | 35 | PB7 | Output | 142 |

Notes:

1. The address bits 0–7, 8–15, and 16–23 each share a single output enable. In this table, the output enables are shown to be associated with the least-significant bit that they control.
2. Direction on the data bus is controlled by a single output enable. It is shown in this table as being associated with D[0].
3. $\overline{\text{MREQ}}$, $\overline{\text{IORQ}}$, $\overline{\text{INSTRDN}}$, $\overline{\text{RD}}$, and $\overline{\text{WR}}$ share an output enable; it is associated in this table with $\overline{\text{WR}}$.



Table 204. Pin to Boundary Scan Cell Mapping (Continued)

| Pin | Direction | Scan Cell # | Pin | Direction | Scan Cell # |
|-----|-----------|-------------|-----|-----------|-------------|
| CS2 | Output | 36 | PB7 | OEN | 143 |
| CS1 | Output | 37 | PB6 | Input | 144 |
| CS0 | Output | 38 | PB6 | Output | 145 |
| A23 | Input | 39 | PB6 | OEN | 146 |
| A23 | Output | 40 | PB5 | Input | 147 |
| A22 | Input | 41 | PB5 | Output | 148 |
| A22 | Output | 42 | PB5 | OEN | 149 |
| A21 | Input | 43 | PB4 | Input | 150 |
| A21 | Output | 44 | PB4 | Output | 151 |
| A20 | Input | 45 | PB4 | OEN | 152 |
| A20 | Output | 46 | PB3 | Input | 153 |
| A19 | Input | 47 | PB3 | Output | 154 |
| A19 | Output | 48 | PB3 | OEN | 155 |
| A18 | Input | 49 | PB2 | Input | 156 |
| A18 | Output | 50 | PB2 | Output | 157 |
| A17 | Input | 51 | PB2 | OEN | 158 |
| A17 | Output | 52 | PB1 | Input | 159 |
| A16 | Input | 53 | PB1 | Output | 160 |
| A16 | Output | 54 | PB1 | OEN | 161 |
| A16 | OEN | 55 | PB0 | Input | 162 |
| A15 | Input | 56 | PB0 | Output | 163 |
| A15 | Output | 57 | PB0 | OEN | 164 |
| A14 | Input | 58 | PC7 | Input | 165 |
| A14 | Output | 59 | PC7 | Output | 166 |
| A13 | Input | 60 | PC7 | OEN | 167 |

Notes:

1. The address bits 0–7, 8–15, and 16–23 each share a single output enable. In this table, the output enables are shown to be associated with the least-significant bit that they control.
2. Direction on the data bus is controlled by a single output enable. It is shown in this table as being associated with D[0].
3. MREQ, IORQ, INSTRDN, RD, and WR share an output enable; it is associated in this table with WR.



Table 204. Pin to Boundary Scan Cell Mapping (Continued)

| Pin | Direction | Scan Cell # | Pin | Direction | Scan Cell # |
|-----|-----------|-------------|-----|-----------|-------------|
| A13 | Output | 61 | PC6 | Input | 168 |
| A12 | Input | 62 | PC6 | Output | 169 |
| A12 | Output | 63 | PC6 | OEN | 170 |
| A11 | Input | 64 | PC5 | Input | 171 |
| A11 | Output | 65 | PC5 | Output | 172 |
| A10 | Input | 66 | PC5 | OEN | 173 |
| A10 | Output | 67 | PC4 | Input | 174 |
| A9 | Input | 68 | PC4 | Output | 175 |
| A9 | Output | 69 | PC4 | OEN | 176 |
| A8 | Input | 70 | PC3 | Input | 177 |
| A8 | Output | 71 | PC3 | Output | 178 |
| A8 | OEN | 72 | PC3 | OEN | 179 |
| A7 | Input | 73 | PC2 | Input | 180 |
| A7 | Output | 74 | PC2 | Output | 181 |
| A6 | Input | 75 | PC2 | OEN | 182 |
| A6 | Output | 76 | PC1 | Input | 183 |
| A5 | Input | 77 | PC1 | Output | 184 |
| A5 | Output | 78 | PC1 | OEN | 185 |
| A4 | Input | 79 | PC0 | Input | 186 |
| A4 | Output | 80 | PC0 | Output | 187 |
| A3 | Input | 81 | PC0 | OEN | 188 |
| A3 | Output | 82 | PD7 | Input | 189 |
| A2 | Input | 83 | PD7 | Output | 190 |
| A2 | Output | 84 | PD7 | OEN | 191 |
| A1 | Input | 85 | PD6 | Input | 192 |

Notes:

1. The address bits 0–7, 8–15, and 16–23 each share a single output enable. In this table, the output enables are shown to be associated with the least-significant bit that they control.
2. Direction on the data bus is controlled by a single output enable. It is shown in this table as being associated with D[0].
3. MREQ, IORQ, INSTRDN, RD, and WR share an output enable; it is associated in this table with WR.



Table 204. Pin to Boundary Scan Cell Mapping (Continued)

| Pin | Direction | Scan Cell # | Pin | Direction | Scan Cell # |
|-----------------|-----------|-------------|-----|-----------|-------------|
| A1 | Output | 86 | PD6 | Output | 193 |
| A0 | Input | 87 | PD6 | OEN | 194 |
| A0 | Output | 88 | PD5 | Input | 195 |
| A0 | OEN | 89 | PD5 | Output | 196 |
| \overline{WP} | Input | 90 | PD5 | OEN | 197 |
| MII_MDIO | Input | 91 | PD4 | Input | 198 |
| MII_MDIO | Output | 92 | PD4 | Output | 199 |
| MII_MDIO | OEN | 93 | PD4 | OEN | 200 |
| MII_MDC | Output | 94 | PD3 | Input | 201 |
| MII_RxD3 | Input | 95 | PD3 | Output | 202 |
| MII_RxD2 | Input | 96 | PD3 | OEN | 203 |
| MII_RxD1 | Input | 97 | PD2 | Input | 204 |
| MII_RxD0 | Input | 98 | PD2 | Output | 205 |
| MII_Rx_DV | Input | 99 | PD2 | OEN | 206 |
| MII_Rx_CLK | Input | 100 | PD1 | Input | 207 |
| MII_Rx_ER | Input | 101 | PD1 | Output | 208 |
| MII_Tx_ER | Output | 102 | PD1 | OEN | 209 |
| MII_Tx_CLK | Input | 103 | PD0 | Input | 210 |
| MII_Tx_EN | Output | 104 | PD0 | Output | 211 |
| MII_TxD0 | Output | 105 | PD0 | OEN | 212 |
| MII_TxD1 | Output | 106 | | | |

Notes:

1. The address bits 0–7, 8–15, and 16–23 each share a single output enable. In this table, the output enables are shown to be associated with the least-significant bit that they control.
2. Direction on the data bus is controlled by a single output enable. It is shown in this table as being associated with D[0].
3. MREQ, IORQ, INSTRDN, RD, and WR share an output enable; it is associated in this table with \overline{WR} .



Usage

Boundary scan functionality is utilized by issuing the appropriate Test Access Port (TAP) instruction and shifting data accordingly. Both of these steps are accomplished using the JTAG interface. To activate the TAP (see the [OCI Activation](#) section on page 312), the TCK pin must be driven Low at least two CPU system clock cycles prior to the deassertion of the RESET pin. Otherwise, the OCI-JTAG features are disabled.

As per the IEEE 1149.1 specification, the boundary scan cells capture system I/O on the rising edge of TCK during the CAPTURE_DR state. This captured data is shifted on the rising edge of TCK while in the SHIFT_DR state. Pins and logic receive shifted data only when enabled, and only on the falling edge of TCK during the UPDATE_DR state, after shifting is completed.

Refer to the Application Note titled *Using BSDL Files with eZ80[®] and eZ80Acclaim![™] Devices (AN0114)* on the [ZiLOG website](#) for more information about eZ80F91 boundary scan support.

Boundary Scan Instructions

The eZ80F91 device's boundary scan architecture supports the following instructions:

- BYPASS (required)
- SAMPLE (required)
- EXTEST (required)
- PRELOAD (required)
- IDCODE (optional)

Phase-Locked Loop

Overview

The Phase-Locked-Loop (PLL) is a programmable frequency multiplier that satisfies the equation $SCLK (Hz) = N * F_{OSC}(Hz)$. A diagram of the PLL block is shown in Figure 60.

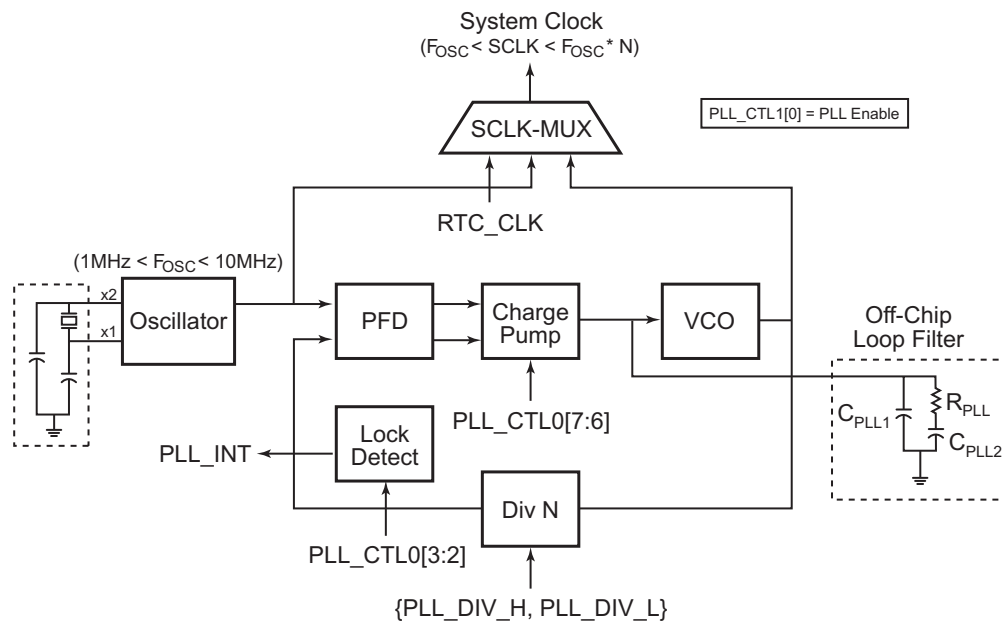

Figure 60. Phase-Locked Loop Block Diagram

The seven main blocks of the PLL are:

- Phase Frequency Detector
- Charge Pump
- Voltage Controlled Oscillator
- Loop Filter
- Divider
- MUX/CLK Sync
- Lock Detect

Each of these blocks is described in this overview section.

Phase Frequency Detector

The Phase Frequency Detector (PFD) is a digital block. The 2 inputs are the reference clock (XTAL oscillator; see the [On-Chip Oscillators](#) section on page 342) and the PLL divider output. The 2 outputs drive the internal charge pump and represent the error (or difference) between the falling edges of the PFD inputs.

Charge Pump

The Charge Pump is an analog block that is driven by 2 digital inputs from the PFD that control its programmable current sources. The internal current source contains four programmable values: 1.5 mA, 1 mA, 500 μ A, and 100 μ A. These values are selected by PLL_CTRL1[7:6]. The selected current drive is sinked/sourced onto the loop-filter node according to the error (or difference) between the falling edges of the PFD inputs. Ideally, when the PLL is locked, there are no errors (error = 0) and no current is sourced/sinked onto the loop-filter node.

Voltage Controlled Oscillator

The Voltage Controlled Oscillator is an analog block that exhibits an output frequency proportional to its input voltage. The VCO input is driven from the charge pump and filtered via the off-chip loop filter.

Loop Filter

The Loop Filter comprises off-chip passive components (usually 1 resistor and 2 capacitors) that filter/integrate charge from the internal charge pump. The filtered node also drives the VCO input, which creates a proportional frequency output. When the PLL is not used, the Loop Filter pin should be a *No Connect*.

Divider

The Divider is a digital, programmable downcounter. The divider input is driven by the VCO. The divider output drives the PFD. The function of the Divider is to divide the frequency of its input signal by a programmable factor N and supply the result in its output.

MUX/CLK Sync

The MUX/CLK Sync is a digital, software-controllable multiplexer that selects between PLL or the XTAL oscillator as the system clock (SCLK). A PLL source can only be selected after the PLL is *locked* (via the lock detect block) to allow glitch-free clock switching.

Lock Detect

The Lock Detect digital block analyzes the PFD output for a locked condition. The PLL block of the eZ80F91 device is considered locked when the error (or difference) between the reference clock and divided-down VCO is less than the minimum timing lock criteria for the number of consecutive reference clock cycles. The lock criteria is selected in the PLL Control Register, PLL_CTL0[LDS_CTL]. When the locked condition is met, this block outputs a logic High signal (lock) that can interrupt the CPU.

www.DataSheet4U.com

PLL Normal Operation

By default (after system reset) the PLL is disabled and SCLK = XTAL oscillator. Assuming the proper loop filter, supply voltages and external oscillator are correctly configured, the PLL can be enabled. The SCLK/Timer cannot choose the PLL as its source until the PLL is locked, as determined by the lock detect block. By forcing the PLL to be locked prior to enabling the PLL as a SCLK/Timer source, it is assured to be stable and accurate.

The programming flow for normal PLL operation is shown in Figure 61.

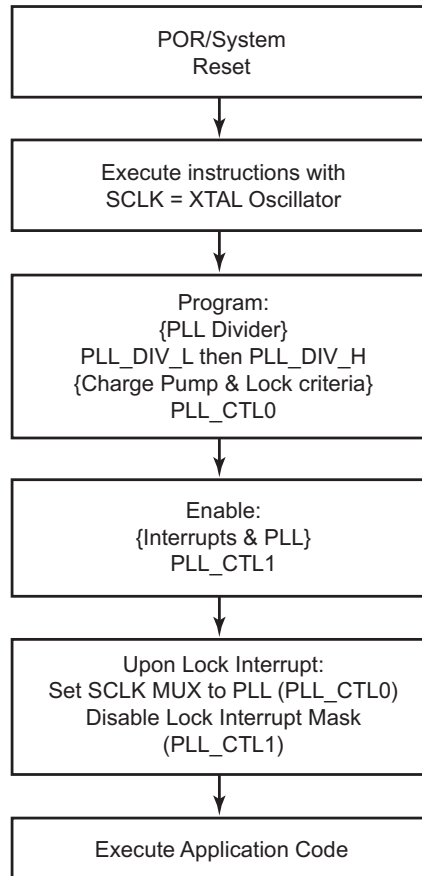

Figure 61. Normal PLL Programming Flow

Power Requirement to the Phase-Locked Loop Function

Regardless of whether or not the developer chooses to use the PLL module block as a clock source for the eZ80F91 device, the PLL_V_{DD} (pin 87) must be connected to a V_{DD} supply and the PLL_V_{SS} (pin 84) must be connected to a V_{SS} supply for proper operation of the eZ80F91 using any system clock source.

PLL Registers

PLL Divider Control Register—Low and High Bytes

This register is designed such that the 11-bit divider value is loaded into the divider module whenever the PLL_DIV_H register is written. Therefore, the procedure should be to load the PLL_DIV_L register, followed by the PLL_DIV_H register, for the divider to receive the appropriate value.



The divider is designed such that any divider value less than 2 is ignored; a value of 2 is used in its place.

The least-significant byte of PLL divider N is set via the corresponding bits in the PLL_DIV_L register. See Tables 205 and 206.

► **Note:** The PLL divider register can only be written to when the PLL is disabled. A read-back of the PLL Divider registers returns 0.

www.DataSheet4U.com

**Table 205. PLL Divider Register—Low Bytes
(PLL_DIV_L = 005Ch)**

| Bit | 7 | 6 | 5 | 4 | 3 | 2 | 1 | 0 |
|-------------------|---|---|---|---|---|---|---|---|
| Reset | 0 | 0 | 0 | 0 | 0 | 0 | 1 | 0 |
| CPU Access | W | W | W | W | W | W | W | W |

Note: W = Write only.

| Bit Position | Value | Description |
|--------------------|-------------|--|
| [7:0] PLL_DIV_L | 00h– FFh | These bits represent the Low byte of the 11-bit PLL divider value. The complete PLL divider value is returned by {PLL_DIV_H, PLL_DIV_L}. |

**Table 206. PLL Divider Register—High Bytes
(PLL_DIV_H = 005Dh)**

| Bit | 7 | 6 | 5 | 4 | 3 | 2 | 1 | 0 |
|-------------------|---|---|---|---|---|---|---|---|
| Reset | 0 | 0 | 0 | 0 | 0 | 0 | 0 | 0 |
| CPU Access | W | W | W | W | W | W | W | W |

Note: R = Read only; R/W = Read/Write.

| Bit Position | Value | Description |
|--------------------|-------|---|
| [7:3] | 00h | Reserved |
| [2:0] PLL_DIV_H | 0h–7h | These bits represent the High byte of the 11-bit PLL divider value. The complete PLL divider value is returned by {PLL_DIV_H, PLL_DIV_L}. |



PLL Control Register 0

The charge pump program, lock detect sensitivity, and system clock source selections can be set using this register. A brief description of each of these PLL Control Register 0 attributes is listed below, and further described in Table 207.

Charge Pump Program (CHRP_CTL). Selects one of four values of charge pump current.

Lock Detect Sensitivity (LDS_CTL). Determines the lock criteria for the PLL.

System Clock Source (CLK_MUX). Selects the system clock source from a choice of the external crystal oscillator (XTAL), PLL, or Real-Time Clock crystal oscillator.

Table 207. PLL Control Register 0
(PLL_CTL0 = 005Eh)

| Bit | 7 | 6 | 5 | 4 | 3 | 2 | 1 | 0 |
|-------------------|-----|-----|---|---|-----|-----|-----|-----|
| Reset | 0 | 0 | 0 | 0 | 0 | 0 | 0 | 0 |
| CPU Access | R/W | R/W | R | R | R/W | R/W | R/W | R/W |

Note: R = Read Only; R/W = Read/Write.

| Bit Position | Value | Description |
|--------------------|-------|--|
| [7:6] CHRP_CTL1 | 00 | Charge pump current = 100µA. |
| | 01 | Charge pump current = 500µA. |
| | 10 | Charge pump current = 1.0mA. |
| | 11 | Charge pump current = 1.5mA. |
| [5:4] | 00 | Reserved. |
| [3:2] LDS_CTL1 | 00 | Lock criteria—8 consecutive cycles of 20ns. |
| | 01 | Lock criteria—16 consecutive cycles of 20ns. |
| | 10 | Lock criteria—8 consecutive cycles of 400ns. |
| | 11 | Lock criteria—16 consecutive cycles of 400ns. |
| [1:0] CLK_MUX | 00 | System clock source is the external crystal oscillator. |
| | 01 | System clock source is the PLL. ² |
| | 10 | System clock source is the Real-Time Clock crystal oscillator. |
| | 11 | Reserved (previous select is preserved). |

Notes:

1. Bits can only be programmed when the PLL is disabled. The PLL is disabled when PLL_CTL1 bit 0 is equal to 0.
2. PLL cannot be selected when disabled or *out of lock*.



PLL Control Register 1

The PLL is enabled using this register. PLL lock-detect status, the PLL interrupt signals and the PLL interrupt enables are accessed via this register. A brief description of each of these PLL Control Register 1 attributes is listed below, and further described in Table 208.

Lock Status (LCK_STATUS). The current lock bit out of the PLL is synchronized and can be read via this bit.

Interrupt Lock (INT_LOCK). This signal feeds the interrupt line out of the CLKGEN module and indicates that a rising edge on the lock signal out of the PLL has been observed.

Interrupt Unlock (INT_UNLOCK). This signal feeds the interrupt line out of the clk-gen module and indicates that a falling edge on the lock signal out of the PLL has been observed.

Interrupt Lock Enable (INT_LOCK_EN). This signal enables the interrupt lock bit.

Interrupt Unlock Enable (INT_UNLOCK_EN). This signal enables the interrupt unlock bit.

PLL Enable (PLL_ENABLE). Enables/disables the PLL.

**Table 208. PLL Control Register 1
(PLL_CTL1 = 005Fh)**

| Bit | 7 | 6 | 5 | 4 | 3 | 2 | 1 | 0 |
|-------------------|---|---|---|-----|-----|-----|-----|-----|
| Reset | 0 | 0 | 0 | 0 | 0 | 0 | 0 | 0 |
| CPU Access | R | R | R | R/W | R/W | R/W | R/W | R/W |

Note: R = Read Only; R/W = Read/Write.

| Bit Position | Value | Description |
|-----------------|-------|---|
| [7:6] | 00 | Reserved |
| 5 LCK_STATUS | 0 | PLL is currently out of lock. |
| | 1 | PLL is currently locked. |
| 4 INT_LOCK | 0 | Lock signal from PLL has not risen since last time register was read. |
| | 1 | Interrupt generated when PLL enters lock mode. Held until register is read. |



| Bit Position | Value | Description |
|--------------------|-------|---|
| 3 INT_UNLOCK | 0 | Lock signal from PLL has not fallen since last time register was read |
| | 1 | Interrupt generated when PLL goes out of lock. Held until register is read. |
| 2 INT_LOCK_EN | 0 | Interrupt generation for PLL locked condition (Bit 4) is disabled. |
| | 1 | Interrupt generation for PLL locked condition is enabled. |
| 1 INT_UNLOCK_EN | 0 | Interrupt generation for PLL unlocked condition (Bit 3) is disabled. |
| | 1 | Interrupt generation for PLL unlocked condition is enabled. |
| 0 PLL_ENABLE | 0 | PLL is disabled. ¹ |
| | 1 | PLL is enabled. |

Notes:

1. PLL cannot be disabled if the CLK_MUX bit of PLL_CTL0[1:0] is set to 01, because the PLL is selected as the clock source.

PLL Characteristics

The operating and testing characteristics for the PLL are described in Table 209.

- **Note:** Not all conditions are tested in production test. The values in Table 209 are for design and characterization only.

Table 209. PLL Characteristics

| Symbol | Parameter | Test Condition | Min | Typ | Max | Units |
|-----------------------|--|---|-------|-------|-------|-------|
| I _{OHCP_OUT} | High level output current for CP_OUT pin (programmed value ±42%) | 3.0 < V _{DD} < 3.6 0.6 < PD_OUT < V _{DD} - 0.6 PLL_CTL0[7:6] = 11 | -0.86 | -1.50 | -2.13 | mA |
| I _{OLCP_OUT} | Low level output current for CP_OUT pin (programmed value ±42%) | 3.0 < V _{DD} < 3.6 0.6 < PD_OUT < V _{DD} - 0.6 PLL_CTL0[7:6] = 11 | 0.86 | 1.50 | 2.13 | mA |
| I _{OHCP_OUT} | High level output current for CP_OUT pin (programmed value ±42%) | 3.0 < V _{DD} < 3.6 0.6 < PD_OUT < V _{DD} - 0.6 PLL_CTL0[7:6] = 10 | -0.42 | -1.0 | -1.42 | mA |

Table 209. PLL Characteristics (Continued)

| Symbol | Parameter | Test Condition | Min | Typ | Max | Units |
|-----------------|---|--|------|------|------|---------|
| I_{OLCP_OUT} | Low level output current for CP_OUT pin (programmed value $\pm 42\%$) | $3.0 < V_{DD} < 3.6$ $0.6 < PD_OUT < V_{DD} - 0.6$ PLL_CTL0[7:6] = 10 | 0.42 | 1.0 | 1.42 | mA |
| I_{OHCP_OUT} | High level output current for CP_OUT pin (programmed value $\pm 42\%$) | $3.0 < V_{DD} < 3.6$ $0.6 < PD_OUT < V_{DD} - 0.6$ PLL_CTL0[7:6] = 01 | -210 | -500 | -710 | μA |
| I_{OLCP_OUT} | Low level output current for CP_OUT pin (programmed value $\pm 42\%$) | $3.0 < V_{DD} < 3.6$ $0.6 < PD_OUT < V_{DD} - 0.6$ PLL_CTL0[7:6] = 01 | 210 | 500 | 710 | μA |
| I_{OHCP_OUT} | High level output current for CP_OUT pin (programmed value $\pm 42\%$) | $3.0 < V_{DD} < 3.6$ $0.6 < PD_OUT < V_{DD} - 0.6$ PLL_CTL0[7:6] = 00 | -42 | -100 | -142 | μA |
| I_{OLCP_OUT} | Low level output current for CP_OUT pin (programmed value $\pm 42\%$) | $3.0 < V_{DD} < 3.6$ $0.6 < PD_OUT < V_{DD} - 0.6$ PLL_CTL0[7:6] = 00 | 42 | 100 | 142 | μA |
| Match | $I_{OHCP_OUT} - I_{OLCP_OUT}$ current match | $3.0 < V_{DD} < 3.6$ $0.6 < CP_OUT < V_{DD} - 0.6$ PLL_CTL0[7:6] = XX | -15 | | +15 | % |
| I_{LCP_OUT} | Tristate leakage on CP_OUT output pin | CP_OUT tristated | -1 | | 1 | μA |
| F_{OSC} | Crystal oscillator frequency | PLL_CTL0[5:4] = 01 | 1M | | 10M | Hz |
| F_{VCO} | VCO frequency | Recommended operating conditions | | 50 | | MHz |
| G_{VCO} | VCO Gain | Recommended operating conditions | 36 | | 120 | MHz/V |
| D1 | SCLK Duty Cycle from PLL or XTALOSC source. | Recommended operating conditions | 45 | 50 | 55 | % |
| T1A | PLL Clock Jitter | $F_{VCO} = 50\text{MHz}$. XTALOSC = 10MHz | | 350 | 500 | ps |
| Lock2 | PLL Lock-Time | $F_{VCO} = 50\text{MHz}$. XTALOSC = 3.579MHz $C_{PLL1} = 220\text{pF}$, $R_{PLL} = 499\Omega$, $C_{PLL2} = 0.056\mu\text{F}$ | | | | s |
| I_{OH1} (XTL) | High-level Output Current for XTAL2 pin | $V_{OH} = V_{DD} - 0.4\text{V}$ PLL_CTL0[5:4] = 01 | -0.3 | | | mA |
| I_{OL1} (XTL) | Low-level Output Current for XTAL2 pin | $V_{OL} = 0.4\text{V}$ PLL_CTL0[5:4] = 01 | 0.6 | | | mA |



Table 209. PLL Characteristics (Continued)

| Symbol | Parameter | Test Condition | Min | Typ | Max | Units |
|-------------------------------|--|--|-----|-----|-----|-------|
| I_{OH2} (XTL) | High-level Output Current for XTAL2 pin | $V_{OH} = V_{DD} - 0.4V$ $PLL_CTL0[5:4] = 11$ | | | | mA |
| I_{OL2} (XTL) | Low-level Output Current for XTAL2 pin | $V_{OL} = 0.4V$ $PLL_CTL0[5:4] = 11$ | | | | mA |
| V_{PP3M} (XTL) | Peak-to-peak voltage under oscillator conditions for XTAL2 pin | $F_{OSC} = 3.579MHz$ $C_{x1} = 10pF$ $C_{x2} = 10pF$ | | | | V |
| V_{PP10M} (XTL) | Peak-to-peak voltage under oscillator conditions for XTAL2 pin | $F_{OSC} = 10MHz$ $C_{x1} = 10pF$ $C_{x2} = 10pF$ | | | | V |
| C_{XTAL1} (package type) | Capacitance measured from XTAL1 pin to GND | $T = 25^{\circ}C$ | | | | pF |
| C_{XTAL2} (package type) | Capacitance measured from XTAL2 pin to GND | $T = 25^{\circ}C$ | | | | pF |
| C_{LOOP} (package type) | Capacitance measured from loop filter pin to GND | $T = 25^{\circ}C$ | | | | pF |

eZ80[®] CPU Instruction Set

Tables 210 through 219 indicate the CPU instructions available for use with the eZ80F91 device. The instructions are grouped by class. More detailed information is available in the eZ80 CPU User Manual (UM0077), available on zilog.com.

www.DataSheet4U.com

Table 210. Arithmetic Instructions

| Mnemonic | Instruction |
|----------|----------------------------|
| ADC | Add with Carry |
| ADD | Add without Carry |
| CP | Compare with Accumulator |
| DAA | Decimal Adjust Accumulator |
| DEC | Decrement |
| INC | Increment |
| MLT | Multiply |
| NEG | Negate Accumulator |
| SBC | Subtract with Carry |
| SUB | Subtract without Carry |

Table 211. Bit Manipulation Instructions

| Mnemonic | Instruction |
|----------|-------------|
| BIT | Bit Test |
| RES | Reset Bit |
| SET | Set Bit |

Table 212. Block Transfer and Compare Instructions

| Mnemonic | Instruction |
|------------|-------------------------------------|
| CPD (CPDR) | Compare and Decrement (with Repeat) |
| CPI (CPIR) | Compare and Increment (with Repeat) |

Table 212. Block Transfer and Compare Instructions

| Mnemonic | Instruction |
|------------|----------------------------------|
| LDD (LDDR) | Load and Decrement (with Repeat) |
| LDI (LDIR) | Load and Increment (with Repeat) |

www.DataSheet4U.com

Table 213. Exchange Instructions

| Mnemonic | Instruction |
|----------|---------------------------------------|
| EX | Exchange registers |
| EXX | Exchange CPU Multibyte register banks |

Table 214. Input/Output Instructions

| Mnemonic | Instruction |
|--------------|---|
| IN | Input from I/O |
| IN0 | Input from I/O on Page 0 |
| IND (INDR) | Input from I/O and Decrement (with Repeat) |
| INDRX | Input from I/O and Decrement Memory Address with Stationary I/O Address |
| IND2 (IND2R) | Input from I/O and Decrement (with Repeat) |
| INDM (INDMR) | Input from I/O and Decrement (with Repeat) |
| INI (INIR) | Input from I/O and Increment (with Repeat) |
| INIRX | Input from I/O and Increment Memory Address with Stationary I/O Address |
| INI2 (INI2R) | Input from I/O and Increment (with Repeat) |
| INIM (INIMR) | Input from I/O and Increment (with Repeat) |
| OTDM (OTDMR) | Output to I/O and Decrement (with Repeat) |
| OTDRX | Output to I/O and Decrement Memory Address with Stationary I/O Address |
| OTIM (OTIMR) | Output to I/O and Increment (with Repeat) |
| OTIRX | Output to I/O and Increment Memory Address with Stationary I/O Address |
| OUT | Output to I/O |

Table 214. Input/Output Instructions

| Mnemonic | Instruction |
|---------------|---|
| OUT0 | Output to I/O on Page 0 |
| OUTD (OTDR) | Output to I/O and Decrement (with Repeat) |
| OUTD2 (OTD2R) | Output to I/O and Decrement (with Repeat) |
| OUTI (OTIR) | Output to I/O and Increment (with Repeat) |
| OUTI2 (OTI2R) | Output to I/O and Increment (with Repeat) |
| TSTIO | Test I/O |

Table 215. Load Instructions

| Mnemonic | Instruction |
|----------|------------------------|
| LD | Load |
| LEA | Load Effective Address |
| PEA | Push Effective Address |
| POP | Pop |
| PUSH | Push |

Table 216. Logical Instructions

| Mnemonic | Instruction |
|----------|------------------------|
| AND | Logical AND |
| CPL | Complement Accumulator |
| OR | Logical OR |
| TST | Test Accumulator |
| XOR | Logical Exclusive OR |

Table 217. Processor Control Instructions

| Mnemonic | Instruction |
|----------|-----------------------|
| CCF | Complement Carry Flag |
| DI | Disable Interrupts |

Table 217. Processor Control Instructions

| Mnemonic | Instruction |
|-----------------|------------------------------|
| EI | Enable Interrupts |
| HALT | Halt |
| IM | Interrupt Mode |
| NOP | No Operation |
| RSMIX | Reset Mixed-Memory Mode Flag |
| SCF | Set Carry Flag |
| SLP | Sleep |
| STMIX | Set Mixed-Memory Mode Flag |

Table 218. Program Control Instructions

| Mnemonic | Instruction |
|-----------------|-----------------------------------|
| CALL | Call Subroutine |
| CALL cc | Conditional Call Subroutine |
| DJNZ | Decrement and Jump if Nonzero |
| JP | Jump |
| JP cc | Conditional Jump |
| JR | Jump Relative |
| JR cc | Conditional Jump Relative |
| RET | Return |
| RET cc | Conditional Return |
| RETI | Return from Interrupt |
| RETN | Return from Nonmaskable interrupt |
| RST | Restart |

Table 219. Rotate and Shift Instructions

| Mnemonic | Instruction |
|-----------------|-------------------------|
| RL | Rotate Left |
| RLA | Rotate Left–Accumulator |



Table 219. Rotate and Shift Instructions

| Mnemonic | Instruction |
|-----------------|-----------------------------------|
| RLC | Rotate Left Circular |
| RLCA | Rotate Left Circular–Accumulator |
| RLD | Rotate Left Decimal |
| RR | Rotate Right |
| RRA | Rotate Right–Accumulator |
| RRC | Rotate Right Circular |
| RRCA | Rotate Right Circular–Accumulator |
| RRD | Rotate Right Decimal |
| SLA | Shift Left Arithmetic |
| SRA | Shift Right Arithmetic |
| SRL | Shift Right Logical |

www.DataSheet4U.com



Op-Code Map

Tables 220 through 226 indicate the hex values for each of the eZ80[®] instructions.

Table 220. Op Code Map—First Op Code

Legend

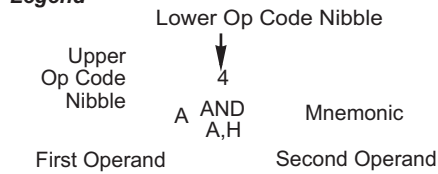

| Upper Nibble (Hex) | Lower Nibble (Hex) | | | | | | | | | | | | | | | |
|--------------------|--------------------|------------|--------------|------------|--------------|-----------|------------|-----------|-----------|-------------|--------------|---------------------------|--------------|---------------------------|------------|---------|
| | 0 | 1 | 2 | 3 | 4 | 5 | 6 | 7 | 8 | 9 | A | B | C | D | E | F |
| 0 | NOP | LD BC, Mmn | LD (BC),A | INC BC | INC B | DEC B | LD B,n | RLCA | EX AF,AF' | ADD HL,BC | LD A,(BC) | DEC BC | INC C | DEC C | LD C,n | RRCA |
| 1 | DJNZ d | LD DE, Mmn | LD (DE),A | INC DE | INC D | DEC D | LD D,n | RLA | JR d | ADD HL,DE | LD A,(DE) | DEC DE | INC E | DEC E | LD E,n | RRA |
| 2 | JR NZ,d | LD HL, Mmn | LD (Mmn), HL | INC HL | INC H | DEC H | LD H,n | DAA | JR Z,d | ADD HL,HL | LD HL, (Mmn) | DEC HL | INC L | DEC L | LD L,n | CPL |
| 3 | JR NC,d | LD SP, Mmn | LD (Mmn), A | INC SP | INC (HL) | DEC (HL) | LD (HL),n | SCF | JR CF,d | ADD HL,SP | LD A, (Mmn) | DEC SP | INC A | DEC A | LD A,n | CCF |
| 4 | .SIS suffix | LD B,C | LD B,D | LD B,E | LD B,H | LD B,L | LD B,(HL) | LD B,A | LD C,B | .LIS suffix | LD C,D | LD C,E | LD C,H | LD C,L | LD C,(HL) | LD C,A |
| 5 | LD D,B | LD D,C | .SIL suffix | LD D,E | LD D,H | LD D,L | LD D,(HL) | LD D,A | LD E,B | LD E,C | LD E,D | .LIL suffix | LD E,H | LD E,L | LD E,(HL) | LD E,A |
| 6 | LD H,B | LD H,C | LD H,D | LD H,E | LD H,H | LD H,L | LD H,(HL) | LD H,A | LD L,B | LD L,C | LD L,D | LD L,E | LD L,H | LD L,L | LD L,(HL) | LD L,A |
| 7 | LD (HL),B | LD (HL),C | LD (HL),D | LD (HL),E | LD (HL),H | LD (HL),L | HALT | LD (HL),A | LD A,B | LD A,C | LD A,D | LD A,E | LD A,H | LD A,L | LD A,(HL) | LD A,A |
| 8 | ADD A,B | ADD A,C | ADD A,D | ADD A,E | ADD A,H | ADD A,L | ADD A,(HL) | ADD A,A | ADC A,B | ADC A,C | ADC A,D | ADC A,E | ADC A,H | ADC A,L | ADC A,(HL) | ADC A,A |
| 9 | SUB A,B | SUB A,C | SUB A,D | SUB A,E | SUB A,H | SUB A,L | SUB A,(HL) | SUB A,A | SBC A,B | SBC A,C | SBC A,D | SBC A,E | SBC A,H | SBC A,L | SBC A,(HL) | SBC A,A |
| A | AND A,B | AND A,C | AND A,D | AND A,E | AND A,H | AND A,L | AND A,(HL) | AND A,A | XOR A,B | XOR A,C | XOR A,D | XOR A,E | XOR A,H | XOR A,L | XOR A,(HL) | XOR A,A |
| B | OR A,B | OR A,C | OR A,D | OR A,E | OR A,H | OR A,L | OR A,(HL) | OR A,A | CP A,B | CP A,C | CP A,D | CP A,E | CP A,H | CP A,L | CP A,(HL) | CP A,A |
| C | RET NZ | POP BC | JP NZ, Mmn | JP Mmn | CALL NZ, Mmn | PUSH BC | ADD A,n | RST 00h | RET Z | RET | JP Z, Mmn | Table 221 | CALL Z, Mmn | CALL Mmn | ADC A,n | RST 08h |
| D | RET NC | POP DE | JP NC, Mmn | OUT (n),A | CALL NC, Mmn | PUSH DE | SUB A,n | RST 10h | RET CF | EXX | JP CF, Mmn | IN A,(n) | CALL CF, Mmn | Table 222 | SBC A,n | RST 18h |
| E | RET PO | POP HL | JP PO, Mmn | EX (SP),HL | CALL PO, Mmn | PUSH HL | AND A,n | RST 20h | RET PE | JP (HL) | JP PE, Mmn | EX DE,HL | CALL PE, Mmn | Table 223 | XOR A,n | RST 28h |
| F | RET P | POP AF | JP P, Mmn | DI | CALL P, Mmn | PUSH AF | OR A,n | RST 30h | RET M | LD SP,HL | JP M, Mmn | EI | CALL M, Mmn | Table 224 | CP A,n | RST 38h |

Notes: n = 8-bit data; Mmn = 16- or 24-bit addr or data; d = 8-bit two's-complement displacement.



Table 221. Op Code Map—Second Op Code after 0CBh

Legend

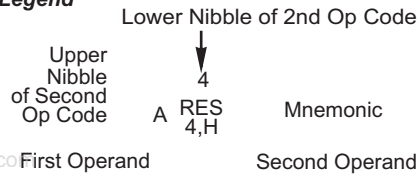

| | | Lower Nibble (Hex) | | | | | | | | | | | | | | | |
|--------------------|---|--------------------|---------|---------|---------|---------|---------|------------|---------|---------|---------|---------|---------|---------|---------|------------|---------|
| | | 0 | 1 | 2 | 3 | 4 | 5 | 6 | 7 | 8 | 9 | A | B | C | D | E | F |
| Upper Nibble (Hex) | 0 | RLC B | RLC C | RLC D | RLC E | RLC H | RLC L | RLC (HL) | RLC A | RRC B | RRC C | RRC D | RRC E | RRC H | RRC L | RRC (HL) | RRC A |
| | 1 | RL B | RL C | RL D | RL E | RL H | RL L | RL (HL) | RL A | RR B | RR C | RR D | RR E | RR H | RR L | RR (HL) | RR A |
| | 2 | SLA B | SLA C | SLA D | SLA E | SLA H | SLA L | SLA (HL) | SLA A | SRA B | SRA C | SRA D | SRA E | SRA H | SRA L | SRA (HL) | SRA A |
| | 3 | | | | | | | | | SRL B | SRL C | SRL D | SRL E | SRL H | SRL L | SRL (HL) | SRL A |
| | 4 | BIT 0,B | BIT 0,C | BIT 0,D | BIT 0,E | BIT 0,H | BIT 0,L | BIT 0,(HL) | BIT 0,A | BIT 1,B | BIT 1,C | BIT 1,D | BIT 1,E | BIT 1,H | BIT 1,L | BIT 1,(HL) | BIT 1,A |
| | 5 | BIT 2,B | BIT 2,C | BIT 2,D | BIT 2,E | BIT 2,H | BIT 2,L | BIT 2,(HL) | BIT 2,A | BIT 3,B | BIT 3,C | BIT 3,D | BIT 3,E | BIT 3,H | BIT 3,L | BIT 3,(HL) | BIT 3,A |
| | 6 | BIT 4,B | BIT 4,C | BIT 4,D | BIT 4,E | BIT 4,H | BIT 4,L | BIT 4,(HL) | BIT 4,A | BIT 5,B | BIT 5,C | BIT 5,D | BIT 5,E | BIT 5,H | BIT 5,L | BIT 5,(HL) | BIT 5,A |
| | 7 | BIT 6,B | BIT 6,C | BIT 6,D | BIT 6,E | BIT 6,H | BIT 6,L | BIT 6,(HL) | BIT 6,A | BIT 7,B | BIT 7,C | BIT 7,D | BIT 7,E | BIT 7,H | BIT 7,L | BIT 7,(HL) | BIT 7,A |
| | 8 | RES 0,B | RES 0,C | RES 0,D | RES 0,E | RES 0,H | RES 0,L | RES 0,(HL) | RES 0,A | RES 1,B | RES 1,C | RES 1,D | RES 1,E | RES 1,H | RES 1,L | RES 1,(HL) | RES 1,A |
| | 9 | RES 2,B | RES 2,C | RES 2,D | RES 2,E | RES 2,H | RES 2,L | RES 2,(HL) | RES 2,A | RES 3,B | RES 3,C | RES 3,D | RES 3,E | RES 3,H | RES 3,L | RES 3,(HL) | RES 3,A |
| | A | RES 4,B | RES 4,C | RES 4,D | RES 4,E | RES 4,H | RES 4,L | RES 4,(HL) | RES 4,A | RES 5,B | RES 5,C | RES 5,D | RES 5,E | RES 5,H | RES 5,L | RES 5,(HL) | RES 5,A |
| | B | RES 6,B | RES 6,C | RES 6,D | RES 6,E | RES 6,H | RES 6,L | RES 6,(HL) | RES 6,A | RES 7,B | RES 7,C | RES 7,D | RES 7,E | RES 7,H | RES 7,L | RES 7,(HL) | RES 7,A |
| | C | SET 0,B | SET 0,C | SET 0,D | SET 0,E | SET 0,H | SET 0,L | SET 0,(HL) | SET 0,A | SET 1,B | SET 1,C | SET 1,D | SET 1,E | SET 1,H | SET 1,L | SET 1,(HL) | SET 1,A |
| | D | SET 2,B | SET 2,C | SET 2,D | SET 2,E | SET 2,H | SET 2,L | SET 2,(HL) | SET 2,A | SET 3,B | SET 3,C | SET 3,D | SET 3,E | SET 3,H | SET 3,L | SET 3,(HL) | SET 3,A |
| | E | SET 4,B | SET 4,C | SET 4,D | SET 4,E | SET 4,H | SET 4,L | SET 4,(HL) | SET 4,A | SET 5,B | SET 5,C | SET 5,D | SET 5,E | SET 5,H | SET 5,L | SET 5,(HL) | SET 5,A |
| | F | SET 6,B | SET 6,C | SET 6,D | SET 6,E | SET 6,H | SET 6,L | SET 6,(HL) | SET 6,A | SET 7,B | SET 7,C | SET 7,D | SET 7,E | SET 7,H | SET 7,L | SET 7,(HL) | SET 7,A |

Notes: n = 8-bit data; Mmn = 16- or 24-bit addr or data; d = 8-bit two's-complement displacement.



Table 222. Op Code Map—Second Op Code After 0DDh

Legend

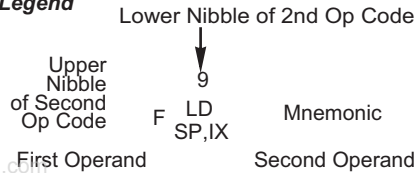

| | | Lower Nibble (Hex) | | | | | | | | | | | | | | | | |
|--------------------|---|--------------------|---------------|--------------|-------------|-------------|-------------|---------------|---------------|----------|---------------|-----------|--------------|------------|---------------------------|--------------|---------------|---------------|
| | | 0 | 1 | 2 | 3 | 4 | 5 | 6 | 7 | 8 | 9 | A | B | C | D | E | F | |
| Upper Nibble (Hex) | 0 | | | | | | | | | | LD BC, (IX+d) | | | | | | ADD IX,BC | |
| | 1 | | | | | | | | | | LD DE, (IX+d) | | | | | | ADD IX,DE | |
| | 2 | | LD IX, Mmn | LD (Mmn), IX | INC IX | INC IXH | DEC IXH | LD IXH,n | LD HL, (IX+d) | | | ADD IX,IX | LD IX, (Mmn) | DEC IX | INC IXL | DEC IXL | LD IXL,n | LD (IX+d), HL |
| | 3 | | LD IY, (IX+d) | | | INC (IX+d) | DEC (IX+d) | LD (IX+d),n | LD IX, (IX+d) | | | ADD IX,SP | | | | | LD (IX+d), IY | LD (IX+d), IX |
| | 4 | | | | | LD B,IXH | LD B,IXL | LD B, (IX+d) | | | | | | | LD C,IXH | LD C,IXL | LD C, (IX+d) | |
| | 5 | | | | | LD D,IXH | LD D,IXL | LD D, (IX+d) | | | | | | | LD E,IXH | LD E,IXL | LD E, (IX+d) | |
| | 6 | LD IXH,B | LD IXH,C | LD IXH,D | LD IXH,E | LD IXH,IXH | LD IXH,IXL | LD H, (IX+d) | LD IXH,A | LD IXL,B | LD IXL,C | LD IXL,D | LD IXL,E | LD IXL,IXH | LD IXL,IXL | LD L, (IX+d) | LD IXL,A | |
| | 7 | LD (IX+d),B | LD (IX+d),C | LD (IX+d),D | LD (IX+d),E | LD (IX+d),H | LD (IX+d),L | | LD (IX+d),A | | | | | | LD A,IXH | LD A,IXL | LD A, (IX+d) | |
| | 8 | | | | | ADD A,IXH | ADD A,IXL | ADD A, (IX+d) | | | | | | | ADC A,IXH | ADC A,IXL | ADC A, (IX+d) | |
| | 9 | | | | | SUB A,IXH | SUB A,IXL | SUB A, (IX+d) | | | | | | | SBC A,IXH | SBC A,IXL | SBC A, (IX+d) | |
| | A | | | | | AND A,IXH | AND A,IXL | AND A, (IX+d) | | | | | | | XOR A,IXH | XOR A,IXL | XOR A, (IX+d) | |
| | B | | | | | OR A,IXH | OR A,IXL | OR A, (IX+d) | | | | | | | CP A,IXH | CP A,IXL | CP A, (IX+d) | |
| | C | | | | | | | | | | | | | | Table 225 | | | |
| | D | | | | | | | | | | | | | | | | | |
| | E | | POP IX | | EX (SP),IX | | PUSH IX | | | | | JP (IX) | | | | | | |
| | F | | | | | | | | | | | LD SP,IX | | | | | | |

Notes: n = 8-bit data; Mmn = 16- or 24-bit addr or data; d = 8-bit two's-complement displacement.



Table 223. Op Code Map—Second Op Code After 0EDh

Legend

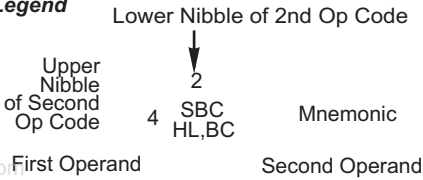

| | | Lower Nibble (Hex) | | | | | | | | | | | | | | | | |
|--------------------|---|--------------------|-------------|--------------|--------------|--------------|--------------|----------|-------------|-----------|------------|-----------|--------------|---------|---------|-------------|-------------|--|
| | | 0 | 1 | 2 | 3 | 4 | 5 | 6 | 7 | 8 | 9 | A | B | C | D | E | F | |
| Upper Nibble (Hex) | 0 | IN0 B,(n) | OUT0 (n),B | LEA BC, IX+d | LEA BC, IY+d | TST A,B | | | LD BC, (HL) | IN0 C,(n) | OUT0 (n),C | | | TST A,C | | | LD (HL), BC | |
| | 1 | IN0 D,(n) | OUT0 (n),D | LEA DE, IX+d | LEA DE, IY+d | TST A,D | | | LD DE, (HL) | IN0 E,(n) | OUT0 (n),E | | | TST A,E | | | LD(HL), DE | |
| | 2 | IN0 H,(n) | OUT0 (n),H | LEA HL, IX+d | LEA HL, IY+d | TST A,H | | | LD HL, (HL) | IN0 L,(n) | OUT0 (n),L | | | TST A,L | | | LD (HL), HL | |
| | 3 | | LD IY, (HL) | LEA IX, IX+d | LEA IY, IY+d | TST A,(HL) | | | LD IX, (HL) | IN0 A,(n) | OUT0 (n),A | | | TST A,A | | LD (HL), IY | LD (HL), IX | |
| | 4 | IN B,(BC) | OUT (BC),B | SBC HL,BC | LD (Mmn), BC | NEG | RETN | IM 0 | LD I,A | IN C,(C) | OUT (C),C | ADC HL,BC | LD BC, (Mmn) | MLT BC | RETI | | LD R,A | |
| | 5 | IN D,(BC) | OUT (BC),D | SBC HL,DE | LD (Mmn), DE | LEA IX, IY+d | LEA IY, IX+d | IM 1 | LD A,I | IN E,(C) | OUT (C),E | ADC HL,DE | LD DE, (Mmn) | MLT DE | | IM 2 | LD A,R | |
| | 6 | IBN H,(C) | OUT (BC),H | SBC HL,HL | LD (Mmn), HL | TST A,n | PEA IX+d | PEA IY+d | RRD | IN L,(C) | OUT (C),L | ADC HL,HL | LD HL, (Mmn) | MLT HL | LD MB,A | LD A,MB | RLD | |
| | 7 | | | SBC HL,SP | LD (Mmn), SP | TST IOn | | SLP | | IN A,(C) | OUT (C),A | ADC HL,SP | LD SP, (Mmn) | MLT SP | STMIX | RSMIX | | |
| | 8 | | | INIM | OTIM | INI2 | | | | | | | INDM | OTDM | IND2 | | | |
| | 9 | | | INIMR | OTIMR | INI2R | | | | | | | INDMR | OTDMR | IND2R | | | |
| | A | LDI | CPI | INI | OUTI | OUTI2 | | | | | LDD | CPD | IND | OUTD | OUTD2 | | | |
| | B | LDIR | CPIR | INIR | OTIR | OTI2R | | | | | LDDR | CPDR | INDR | OTDR | OTD2R | | | |
| | C | | | INIRX | OTIRX | | | | | LD I,HL | | | INDRX | OTDRX | | | | |
| | D | | | | | | | | | LD HL,I | | | | | | | | |
| | E | | | | | | | | | | | | | | | | | |
| | F | | | | | | | | | | | | | | | | | |

Notes: n = 8-bit data; Mmn = 16- or 24-bit addr or data; d = 8-bit two's-complement displacement.



Table 224. Op Code Map—Second Op Code After 0FDh

Legend Lower Nibble of 2nd Op Code

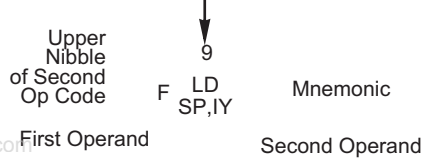

| | | Lower Nibble (Hex) | | | | | | | | | | | | | | | |
|--------------------|---|--------------------|---------------|-------------|-------------|-------------|-------------|---------------|---------------|----------|-----------|--------------|----------|---------------------------|------------|--------------|---------------|
| | | 0 | 1 | 2 | 3 | 4 | 5 | 6 | 7 | 8 | 9 | A | B | C | D | E | F |
| Upper Nibble (Hex) | 0 | | | | | | | | LD BC, (IY+d) | | ADD IY,BC | | | | | | LD (IY+d),BC |
| | 1 | | | | | | | | LD DE, (IY+d) | | ADD IY,DE | | | | | | LD (IY+d),DE |
| | 2 | | LD IY,Mmn | LD (Mmn),IY | INC IY | INC IYH | DEC IYH | LD IYH,n | LD HL, (IY+d) | | ADD IY,IY | LD IY, (Mmn) | DEC IY | INC IYL | DEC IYL | LD IYL,n | LD (IY+d),HL |
| | 3 | | LD IX, (IY+d) | | | INC (IY+d) | DEC (IY+d) | LD (IY+d),n | LD IY, (IY+d) | | ADD IY,SP | | | | | LD (IY+d),IX | LD (IY+d),IY |
| | 4 | | | | | LD B,IYH | LD B,IYL | LD B, (IY+d) | | | | | | | LD C,IYH | LD C,IYL | LD C, (IY+d) |
| | 5 | | | | | LD D,IYH | LD D,IYL | LD D, (IY+d) | | | | | | | LD E,IYH | LD E,IYL | LD E, (IY+d) |
| | 6 | LD IYH,B | LD IYH,C | LD IYH,D | LD IYH,E | LD IYH,IYH | LD IYH,IYL | LD H, (IY+d) | LD IYH,A | LD IYL,B | LD IYL,C | LD IYL,D | LD IYL,E | LD IYL,IYH | LD IYL,IYL | LD L, (IY+d) | LD IYL,A |
| | 7 | LD (IY+d),B | LD (IY+d),C | LD (IY+d),D | LD (IY+d),E | LD (IY+d),H | LD (IY+d),L | | LD (IY+d),A | | | | | LD A,IYH | LD A,IYL | LD A, (IY+d) | |
| | 8 | | | | | ADD A,IYH | ADD A,IYL | ADD A, (IY+d) | | | | | | | ADC A,IYH | ADC A,IYL | ADC A, (IY+d) |
| | 9 | | | | | SUB A,IYH | SUB A,IYL | SUB A, (IY+d) | | | | | | | SBC A,IYH | SBC A,IYL | SBC A, (IY+d) |
| | A | | | | | AND A,IYH | AND A,IYL | AND A, (IY+d) | | | | | | | XOR A,IYH | XOR A,IYL | XOR A, (IY+d) |
| | B | | | | | OR A,IYH | OR A,IYL | OR A, (IY+d) | | | | | | | CP A,IYH | CP A,IYL | CP A, (IY+d) |
| | C | | | | | | | | | | | | | Table 226 | | | |
| | D | | | | | | | | | | | | | | | | |
| | E | | POP IY | | EX (SP),IY | | PUSH IY | | | | | JP (IY) | | | | | |
| | F | | | | | | | | | | | LD SP,IY | | | | | |

Notes: n = 8-bit data; Mmn = 16- or 24-bit addr or data; d = 8-bit two's-complement displacement.



Table 225. Op Code Map—Fourth Byte After 0DDh, 0CBh, and dd

Legend

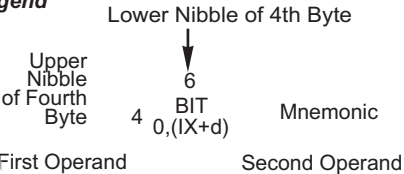

| | | Lower Nibble (Hex) | | | | | | | | | | | | | | | | |
|--------------------|---|--------------------|---|---|---|---|---|------------------|---|---|---|---|---|---|---|---|------------------|--|
| | | 0 | 1 | 2 | 3 | 4 | 5 | 6 | 7 | 8 | 9 | A | B | C | D | E | F | |
| Upper Nibble (Hex) | 0 | | | | | | | RLC (IX+d) | | | | | | | | | RRC (IX+d) | |
| | 1 | | | | | | | RL (IX+d) | | | | | | | | | RR (IX+d) | |
| | 2 | | | | | | | SLA (IX+d) | | | | | | | | | SRA (IX+d) | |
| | 3 | | | | | | | | | | | | | | | | SRL (IX+d) | |
| | 4 | | | | | | | BIT 0, (IX+d) | | | | | | | | | BIT 1, (IX+d) | |
| | 5 | | | | | | | BIT 2, (IX+d) | | | | | | | | | BIT 3, (IX+d) | |
| | 6 | | | | | | | BIT 4, (IX+d) | | | | | | | | | BIT 5, (IX+d) | |
| | 7 | | | | | | | BIT 6, (IX+d) | | | | | | | | | BIT 7, (IX+d) | |
| | 8 | | | | | | | RES 0, (IX+d) | | | | | | | | | RES 1, (IX+d) | |
| | 9 | | | | | | | RES 2, (IX+d) | | | | | | | | | RES 3, (IX+d) | |
| | A | | | | | | | RES 4, (IX+d) | | | | | | | | | RES 5, (IX+d) | |
| | B | | | | | | | RES 6, (IX+d) | | | | | | | | | RES 7, (IX+d) | |
| | C | | | | | | | SET 0, (IX+d) | | | | | | | | | SET 1, (IX+d) | |
| | D | | | | | | | SET 2, (IX+d) | | | | | | | | | SET 3, (IX+d) | |
| | E | | | | | | | SET 4, (IX+d) | | | | | | | | | SET 5, (IX+d) | |
| | F | | | | | | | SET 6, (IX+d) | | | | | | | | | SET 7, (IX+d) | |

Notes: d = 8-bit two's-complement displacement.



Table 226. Op Code Map—Fourth Byte After 0FDh, 0CBh, and dd*

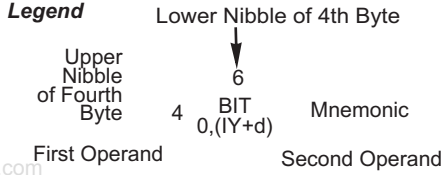

| | | Lower Nibble (Hex) | | | | | | | | | | | | | | | |
|--------------------|---|--------------------|---|---|---|---|---|------------------|---|---|---|---|---|---|---|------------------|---|
| | | 0 | 1 | 2 | 3 | 4 | 5 | 6 | 7 | 8 | 9 | A | B | C | D | E | F |
| Upper Nibble (Hex) | 0 | | | | | | | RLC (IY+d) | | | | | | | | RRC (IY+d) | |
| | 1 | | | | | | | RL (IY+d) | | | | | | | | RR (IY+d) | |
| | 2 | | | | | | | SLA (IY+d) | | | | | | | | SRA (IY+d) | |
| | 3 | | | | | | | | | | | | | | | SRL (IY+d) | |
| | 4 | | | | | | | BIT 0, (IY+d) | | | | | | | | BIT 1, (IY+d) | |
| | 5 | | | | | | | BIT 2, (IY+d) | | | | | | | | BIT 3, (IY+d) | |
| | 6 | | | | | | | BIT 4, (IY+d) | | | | | | | | BIT 5, (IY+d) | |
| | 7 | | | | | | | BIT 6, (IY+d) | | | | | | | | BIT 7, (IY+d) | |
| | 8 | | | | | | | RES 0, (IY+d) | | | | | | | | RES 1, (IY+d) | |
| | 9 | | | | | | | RES 2, (IY+d) | | | | | | | | RES 3, (IY+d) | |
| | A | | | | | | | RES 4, (IY+d) | | | | | | | | RES 5, (IY+d) | |
| | B | | | | | | | RES 6, (IY+d) | | | | | | | | RES 7, (IY+d) | |
| | C | | | | | | | SET 0, (IY+d) | | | | | | | | SET 1, (IY+d) | |
| | D | | | | | | | SET 2, (IY+d) | | | | | | | | SET 3, (IY+d) | |
| | E | | | | | | | SET 4, (IY+d) | | | | | | | | SET 5, (IY+d) | |
| | F | | | | | | | SET 6, (IY+d) | | | | | | | | SET 7, (IY+d) | |

Notes: d = 8-bit two's-complement displacement.

On-Chip Oscillators

The eZ80F91 features two on-chip oscillators for use with an external crystal. The primary oscillator generates the system clock for the internal CPU and the majority of the on-chip peripherals. Alternatively, the X_{IN} input pin can also accept a CMOS-level clock input signal. If an external clock generator is used, the X_{OUT} pin should be left unconnected. The secondary oscillator can drive a 32KHz crystal to generate the time-base for the Real-Time Clock.

Primary Crystal Oscillator Operation

Figure 62 illustrates a recommended configuration for connection with an external 50MHz, 3rd-overtone, parallel-resonant crystal. Recommended crystal specifications are provided in Tables 227 and 228. Printed circuit board layout should add no more than 4pF of stray capacitance to either the X_{IN} or X_{OUT} pins. If oscillation does not occur, the user should try removing C1 for testing and decreasing the value of C_2 by the estimated stray capacitance to decrease loading.

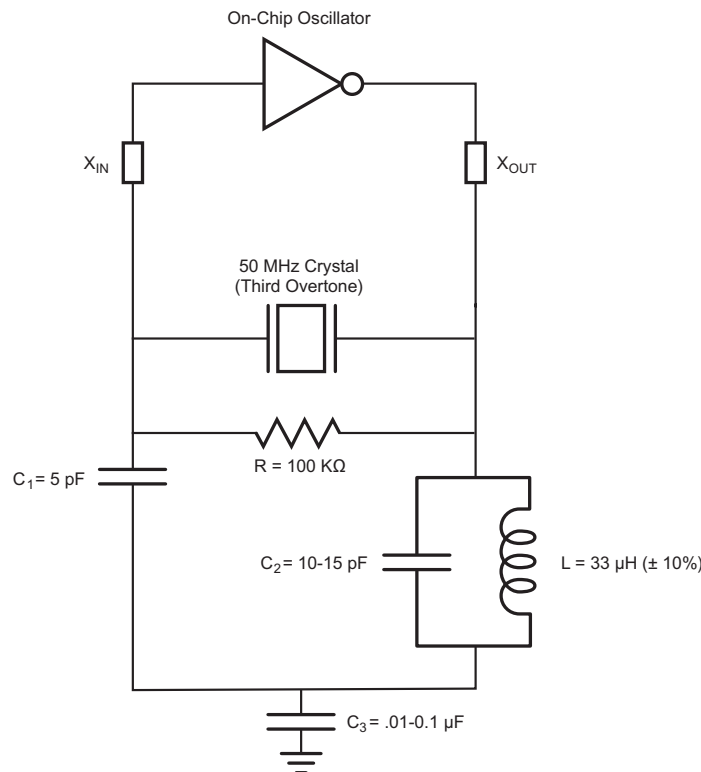

Figure 62. Recommended Crystal Oscillator Configuration—50MHz Operation

Table 227. Recommended Crystal Oscillator Specifications—1MHz Operation

| Parameter | Frequency Dependent Value | Units | Comments |
|-----------------------------|------------------------------|-------|----------|
| Frequency | 1 | MHz | |
| Resonance | Parallel | | |
| Mode | Fundamental | | |
| Series Resistance (R_S) | 750 | Ohms | Maximum |
| Load Capacitance (C_L) | 13 | pF | Maximum |
| Shunt Capacitance (C_0) | 7 | pF | Maximum |
| Drive Level | 1 | mW | Maximum |

Table 228. Recommended Crystal Oscillator Specifications—10MHz Operation

| Parameter | Frequency Dependent Value | Units | Comments |
|-----------------------------|------------------------------|-------|----------|
| Frequency | 10 | MHz | |
| Resonance | Parallel | | |
| Mode | Fundamental | | |
| Series Resistance (R_S) | 35 | Ohms | Maximum |
| Load Capacitance (C_L) | 30 | pF | Maximum |
| Shunt Capacitance (C_0) | 7 | pF | Maximum |
| Drive Level | 1 | mW | Maximum |

32KHz Real-Time Clock Crystal Oscillator Operation

Figure 63 illustrates a recommended configuration for connecting the Real-Time Clock oscillator with an external 32KHz, fundamental-mode, parallel-resonant crystal. The recommended crystal specifications are provided in Table 229. A printed circuit board layout should add no more than 4 pF of stray capacitance to either the RTC_X_{IN} or RTC_X_{OUT} pins. If oscillation does not occur, reduce the values of capacitors C₁ and C₂ to decrease loading.

An on-chip MOS resistor sets the crystal drive current limit. This configuration does not require an external bias resistor across the crystal. An on-chip MOS resistor provides the biasing.

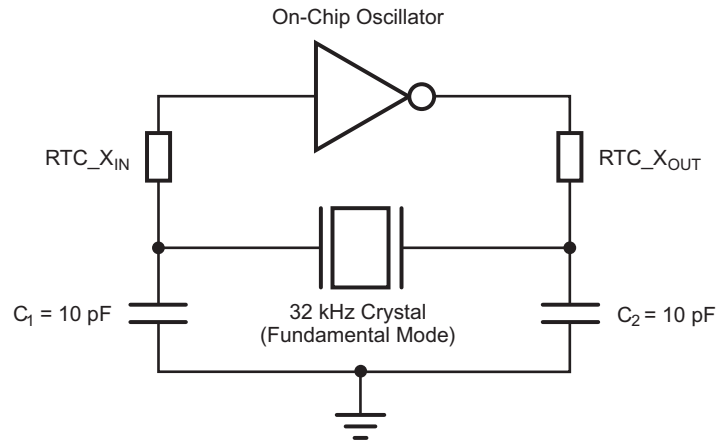

Figure 63. Recommended Crystal Oscillator Configuration—32KHz Operation

Table 229. Recommended Crystal Oscillator Specifications—32KHz Operation

| Parameter | Value | Units | Comments |
|-----------------------------|-------------|------------|----------|
| Frequency | 32 | KHz | 32768 Hz |
| Resonance | Parallel | | |
| Mode | Fundamental | | |
| Series Resistance (R_S) | 40 | k Ω | Maximum |
| Load Capacitance (C_L) | 12.5 | pF | Maximum |
| Shunt Capacitance (C_0) | 3 | pF | Maximum |
| Drive Level | 1 | μ W | Maximum |

Electrical Characteristics

Absolute Maximum Ratings

Stresses greater than those listed in Table 230 can cause permanent damage to the device. These ratings are stress ratings only. Operation of the device at any condition outside those indicated in the operational sections of these specifications is not implied. Exposure to absolute maximum rating conditions for extended periods can affect device reliability. For improved reliability, unused inputs should be tied to one of the supply voltages (V_{DD} or V_{SS}).

Table 230. Absolute Maximum Ratings

| Parameter | Min | Max | Units | Notes |
|---|------|------|--------------------|-------|
| Ambient temperature under bias ($^{\circ}\text{C}$) | -40 | +105 | $^{\circ}\text{C}$ | 1 |
| Storage temperature ($^{\circ}\text{C}$) | -65 | +150 | C | |
| Voltage on any pin with respect to V_{SS} | -0.3 | +5.5 | V | 2 |
| Voltage on V_{DD} pin with respect to V_{SS} | -0.3 | +3.6 | V | |
| Total power dissipation | | 830 | mW | |
| Maximum current out of V_{SS} | | 230 | mA | |
| Maximum current into V_{DD} | | 230 | mA | |
| Maximum current on input and/or inactive output pin | -15 | +15 | μA | |
| Maximum output current from active output pin | -8 | +8 | mA | |

Notes:

1. Operating temperature is specified in DC Characteristics.
2. This voltage applies to all pins except where noted otherwise.

DC Characteristics

Table 231 lists the DC characteristics of the eZ80F91 device.

- **Note:** All data is preliminary and subject to change following completion of production characterization.

Table 231. DC Characteristics

| Symbol | Parameter | $T_A = 0^{\circ}\text{C to } 70^{\circ}\text{C}$ | | $T_A = -40^{\circ}\text{C to } 105^{\circ}\text{C}$ | | Units | Conditions |
|-----------|---------------------------|--|---------------------|---|---------------------|---------------|---|
| | | Min | Max | Min | Max | | |
| V_{DD} | Supply Voltage | 3.0 | 3.6 | 3.0 | 3.6 | V | |
| V_{IL} | Low Level Input Voltage | -0.3 | $0.3 \times V_{DD}$ | -0.3 | $0.3 \times V_{DD}$ | V | |
| V_{IH} | High Level Input Voltage | $0.7 \times V_{DD}$ | 5.5 | $0.7 \times V_{DD}$ | 5.5 | V | |
| V_{OL} | Low Level Output Voltage | | 0.4 | | 0.4 | V | $V_{DD} = 3.0\text{V};$ $I_{OL} = 1\text{mA}$ |
| V_{OH} | High Level Output Voltage | 2.4 | | 2.4 | | V | $V_{DD} = 3.0\text{V};$ $I_{OH} = -1\text{mA}$ |
| V_{RTC} | RTC Supply Voltage | 2.0 | 3.6 | 2.0 | 3.6 | V | |
| I_{IL} | Input Leakage Current | -10 | +10 | -10 | +10 | μA | $V_{DD} = 3.6\text{V};$ $V_{IN} = V_{DD}$ or V_{SS} ¹ |
| I_{TL} | Tristate Leakage Current | -10 | +10 | -10 | +10 | μA | $V_{DD} = 3.6\text{V}$ |
| I_{CCa} | Active Current | | | | 230 | mA | |
| I_{CCh} | HALT Mode Current | | | | 120 | mA | |
| I_{CCs} | SLEEP Mode Current | | | | 850 | μA | |
| I_{RTC} | RTC Supply Current | 2.5 Typical | 10 | 2.5 Typical | 10 | μA | Supply current into V_{RTC} |

Note: ¹This condition excludes all pins with on-chip pull-ups when driven Low.

POR and VBO Electrical Characteristics

Table 232 lists the Power-On Reset and Voltage Brown-Out characteristics of the eZ80F91 device.

Table 232. POR and VBO Electrical Characteristics

www.DataSheet4U.com

| Symbol | Parameter | $T_A = -40^{\circ}\text{C to } 105^{\circ}\text{C}$ | | | Unit | Conditions |
|----------------|--|---|------|------|---------------|--------------------|
| | | Min | Typ | Max | | |
| V_{VBO} | VBO Voltage Threshold | 2.45 | 2.77 | 2.90 | V | $V_{CC} = V_{VBO}$ |
| V_{POR} | POR Voltage Threshold | 2.55 | 2.70 | 2.95 | V | $V_{CC} = V_{POR}$ |
| V_{HYST} | POR/VBO Hysteresis | 55 | 75 | 95 | mV | |
| T_{ANA} | POR/VBO analog RESET duration | 40 | | 100 | μs | |
| T_{VBO_MIN} | VBO pulse reject period | | 10 | | μs | |
| I_{POR_VBO} | POR/VBO DC current consumption | | 40 | 50 | μA | |
| V_{CC_RAMP} | V_{CC} ramp rate requirements to guarantee proper RESET occurs | 0.1 | | 100 | V/ms | |

Flash Memory Characteristics

Table 233 lists the Flash memory characteristics of the eZ80F91 device.

Table 233. Flash Memory Electrical Characteristics and Timing
 $V_{DD} = 3.0 \text{ to } 3.6\text{V}; T_A = -40^{\circ}\text{C to } 105^{\circ}\text{C}$

| Symbol | Minimum | Typical | Maximum | Units | Notes |
|--------------------------|---------|---------|---------|--------|-------------------|
| Flash Byte Read Time | 60 | — | — | ns | |
| Flash Byte Program Time | 65 | — | 85 | ns | |
| Flash Page Erase Time | — | 10 | — | ms | 2KB |
| Flash Mass Erase Time | — | 200 | — | ms | |
| Writes to Single Address | — | — | 2 | | Before Next Erase |
| Flash Row Program Time | — | — | 13.4 | ms | ROW mode |
| Data Retention | 100 | — | — | years | 25°C |
| Endurance | 10,000 | — | — | cycles | |

AC Characteristics

The section provides information about the AC characteristics and timing of the eZ80F91 device. All AC timing information assumes a standard load of 50pF on all outputs. See Table 234.

Note: All data is preliminary and subject to change following completion of production characterization.

Table 234. AC Characteristics

| Symbol | Parameter | $T_A = 0^\circ\text{C to }70^\circ\text{C}$ | | $T_A = -40^\circ\text{C to }105^\circ\text{C}$ | | Units | Conditions |
|------------|-------------------------|---|------|--|------|-------|--|
| | | Min | Max | Min | Max | | |
| T_{XIN} | System Clock Cycle Time | 20 | 1000 | 20 | 1000 | ns | $V_{DD} = 3.0 - 3.6\text{V}$ |
| T_{XINH} | System Clock High Time | 8 | | 8 | | ns | $V_{DD} = 3.0 - 3.6\text{V};$ $T_{CLK} = 20\text{ns}$ |
| T_{XINL} | System Clock Low Time | 8 | | 8 | | ns | $V_{DD} = 3.0 - 3.6\text{V};$ $T_{CLK} = 20\text{ns}$ |
| T_{XINR} | System Clock Rise Time | | 3 | | 3 | ns | $V_{DD} = 3.0 - 3.6\text{V};$ $T_{CLK} = 20\text{ns}$ |
| T_{XINF} | System Clock Fall Time | | 3 | | 3 | ns | $V_{DD} = 3.0 - 3.6\text{V};$ $T_{CLK} = 20\text{ns}$ |
| C_{IN} | Input capacitance | 10 typical | | 10 typical | | pF | Pad library simulation |

Table 235 shows simulated inductance, capacitance, and resistance results for the 144-pin LQFP package at 100MHz operating frequency.

Table 235. Typical 144-LQFP Package Electrical Characteristics*

| Lead | Inductance (nH) | Capacitance (pF) | Resistance (mΩ) |
|----------|-----------------|------------------|-----------------|
| Longest | 6.430 | 1.100 | 62.9 |
| Shortest | 4.230 | 1.070 | 52.6 |

Note: *Package vendor-supplied; 100MHz operating frequency.

External Memory Read Timing

Figure 64 and Table 236 diagram the timing for external memory reads.

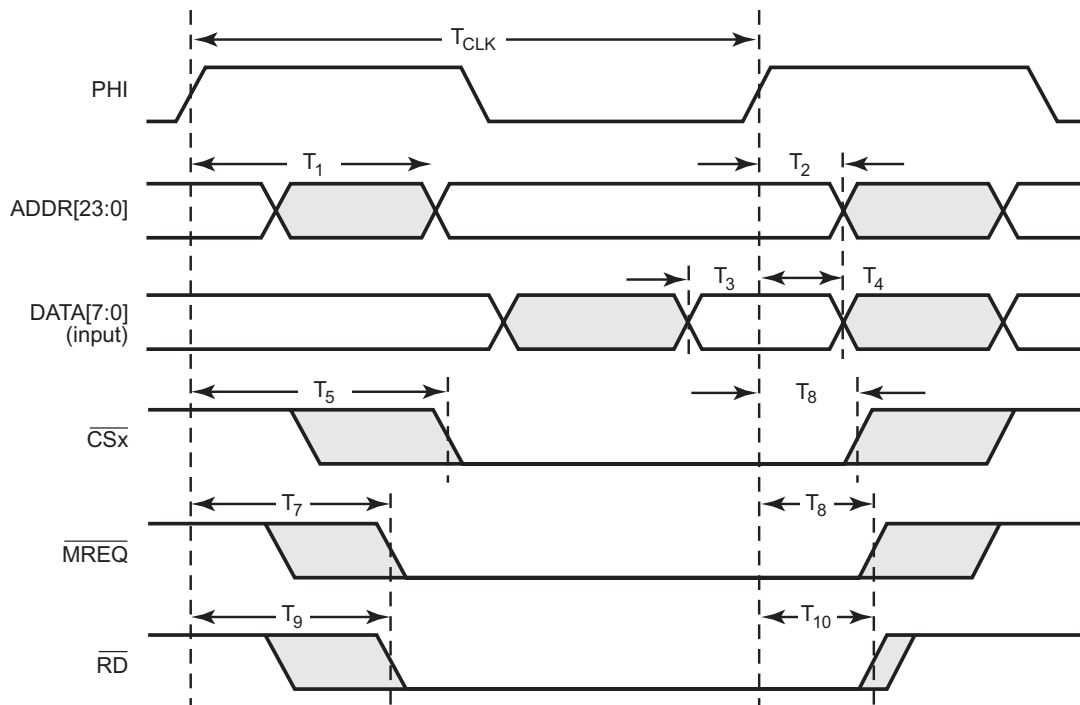

Figure 64. External Memory Read Timing

Table 236. External Memory Read Timing

| Parameter | Abbreviation | Delay (ns) | |
|----------------|---|------------|------|
| | | Min. | Max. |
| T ₁ | PHI Clock Rise to ADDR Valid Delay | — | 6.8 |
| T ₂ | PHI Clock Rise to ADDR Hold Time | 2.2 | — |
| T ₃ | Input DATA Valid to PHI Clock Rise Setup Time | 0.2 | — |
| T ₄ | PHI Clock Rise to DATA Hold Time | 0.9 | — |
| T ₅ | PHI Clock Rise to CSx Assertion Delay | 2.6 | 10.8 |
| T ₆ | PHI Clock Rise to CSx Deassertion Delay | 2.4 | 8.8 |
| T ₇ | PHI Clock Rise to MREQ Assertion Delay | 2.6 | 7.0 |
| T ₈ | PHI Clock Rise to MREQ Deassertion Delay | 2.3 | 6.3 |



Table 236. External Memory Read Timing (Continued)

| Parameter | Abbreviation | Delay (ns) | |
|-----------------|--|------------|------|
| | | Min. | Max. |
| T ₉ | PHI Clock Rise to RD Assertion Delay | 2.7 | 7.0 |
| T ₁₀ | PHI Clock Rise to RD Deassertion Delay | 2.4 | 6.3 |

www.DataSheet4U.com

External Memory Write Timing

Figure 65 and Table 237 diagram the timing for external memory Writes.

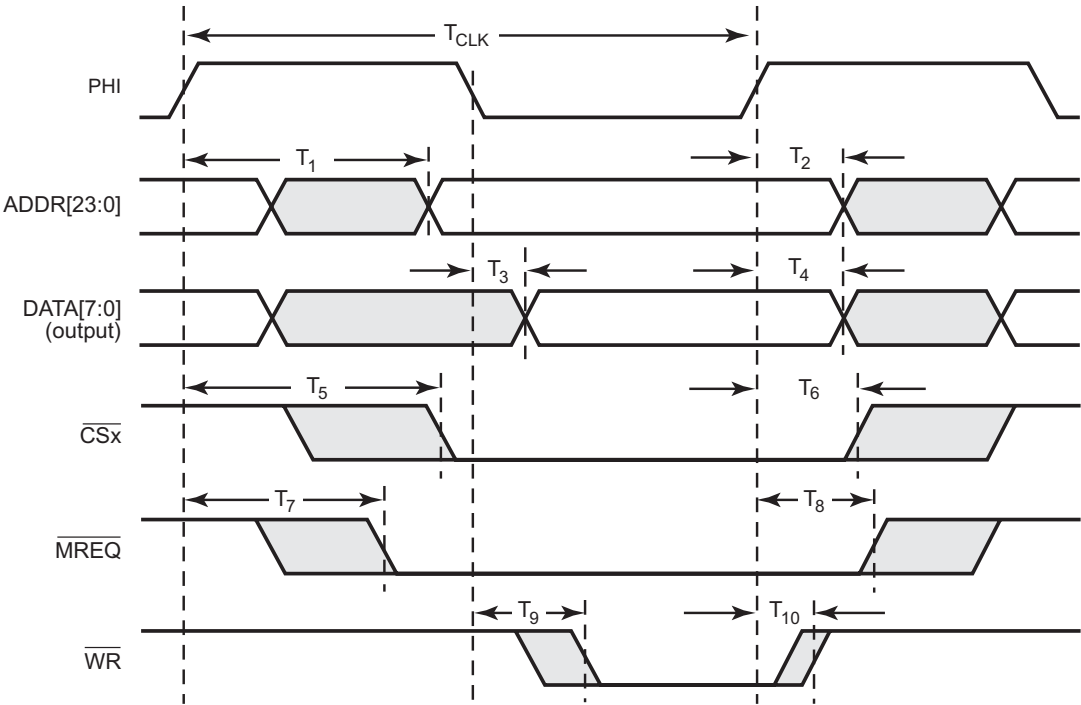

Figure 65. External Memory Write Timing



Table 237. External Memory Write Timing

| Parameter | Abbreviation | Delay (ns) | |
|-----------------|---|------------|------|
| | | Min. | Max. |
| T ₁ | PHI Clock Rise to ADDR Valid Delay | — | 6.8 |
| T ₂ | PHI Clock Rise to ADDR Hold Time | 2.2 | — |
| T ₃ | PHI Clock Fall to Output DATA Valid Delay | — | 7.5 |
| T ₄ | PHI Clock Rise to DATA Hold Time | 2.3 | — |
| T ₅ | PHI Clock Rise to CSx Assertion Delay | 2.6 | 10.8 |
| T ₆ | PHI Clock Rise to CSx Deassertion Delay | 2.4 | 8.8 |
| T ₇ | PHI Clock Rise to MREQ Assertion Delay | 2.6 | 7.0 |
| T ₈ | PHI Clock Rise to MREQ Deassertion Delay | 2.3 | 6.3 |
| T ₉ | PHI Clock Fall to WR Assertion Delay | 1.8 | 4.5 |
| T ₁₀ | PHI Clock Rise to WR Deassertion Delay* | 1.6 | 4.4 |
| | WR Deassertion to ADDR Hold Time | 0.4 | — |
| | WR Deassertion to DATA Hold Time | 0.5 | — |
| | WR Deassertion to CSx Hold Time | 1.2 | — |
| | WR Deassertion to MREQ Hold Time | 0.5 | — |

* At the conclusion of a Write cycle, deassertion of WR always occurs before any change to ADDR, DATA, CSx, or MREQ.

External I/O Read Timing

Figure 66 and Table 238 diagram the timing for external I/O reads. PHI clock rise/fall to signal transition timing is independent of the particular bus mode employed (eZ80, Z80, Intel, or Motorola).

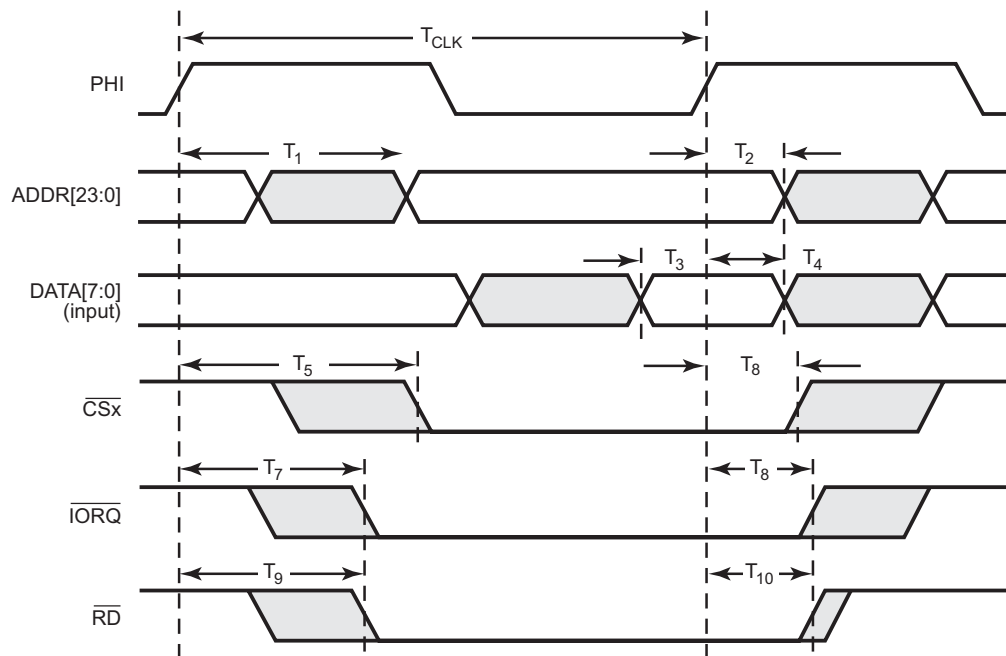

Figure 66. External I/O Read Timing

Table 238. External I/O Read Timing

| Parameter | Abbreviation | Delay (ns) | |
|-----------|--|------------|------|
| | | Min | Max |
| T_1 | PHI Clock Rise to ADDR Valid Delay | — | 6.8 |
| T_2 | PHI Clock Rise to ADDR Hold Time | 2.2 | — |
| T_3 | Input DATA Valid to PHI Clock Rise Setup Time | 0.2 | — |
| T_4 | PHI Clock Rise to DATA Hold Time | 0.9 | — |
| T_5 | PHI Clock Rise to \overline{CSx} Assertion Delay | 2.6 | 10.8 |
| T_6 | PHI Clock Rise to \overline{CSx} Deassertion Delay | 2.4 | 8.8 |
| T_7 | PHI Clock Rise to \overline{IORQ} Assertion Delay | 2.6 | 7.0 |



Table 238. External I/O Read Timing (Continued)

| Parameter | Abbreviation | Delay (ns) | |
|-----------------|--|------------|-----|
| | | Min | Max |
| T ₈ | PHI Clock Rise to IORQ Deassertion Delay | 2.3 | 6.3 |
| T ₉ | PHI Clock Rise to RD Assertion Delay | 2.7 | 7.0 |
| T ₁₀ | PHI Clock Rise to RD Deassertion Delay | 2.4 | 6.3 |

www.DataSheet4U.com

External I/O Write Timing

Figure 67 and Table 239 diagram the timing for external I/O Writes. PHI clock rise/fall to signal transition timing is independent of the particular bus mode employed (eZ80, Z80, Intel, or Motorola).

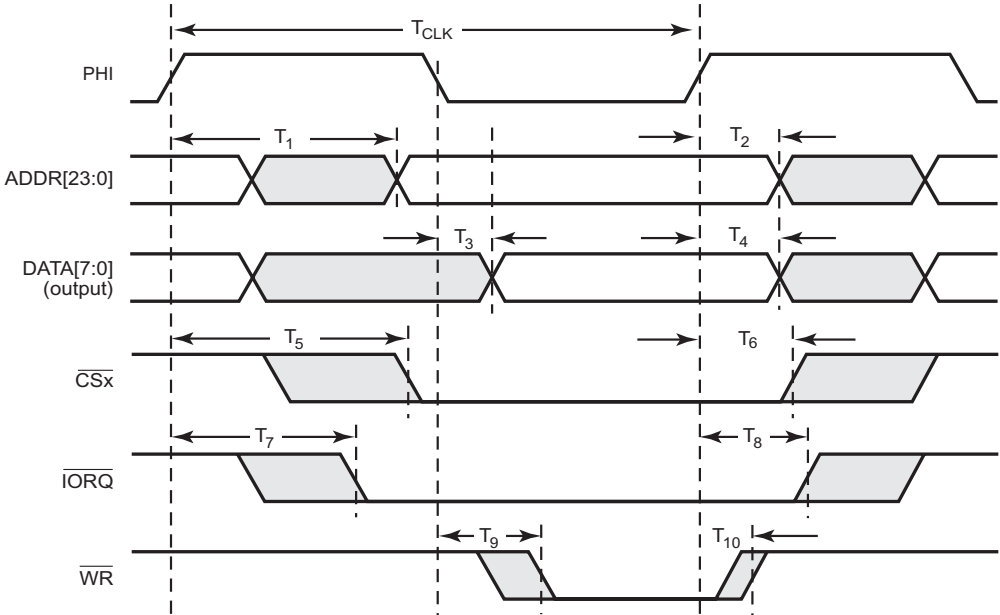

Figure 67. External I/O Write Timing

Table 239. External I/O Write Timing

| Parameter | Abbreviation | Delay (ns) | |
|-----------------|---|------------|------|
| | | Min | Max |
| T ₁ | PHI Clock Rise to ADDR Valid Delay | — | 6.8 |
| T ₂ | PHI Clock Rise to ADDR Hold Time | 2.2 | — |
| T ₃ | PHI Clock Fall to Output DATA Valid Delay | — | 7.5 |
| T ₄ | PHI Clock Rise to DATA Hold Time | 2.3 | — |
| T ₅ | PHI Clock Rise to CSx Assertion Delay | 2.6 | 10.8 |
| T ₆ | PHI Clock Rise to CSx Deassertion Delay | 2.4 | 8.8 |
| T ₇ | PHI Clock Rise to IORQ Assertion Delay | 2.6 | 7.0 |
| T ₈ | PHI Clock Rise to IORQ Deassertion Delay | 2.3 | 6.3 |
| T ₉ | PHI Clock Fall to WR Assertion Delay | 1.8 | 4.5 |
| T ₁₀ | PHI Clock Rise to WR Deassertion Delay* | 1.6 | 4.4 |
| | WR Deassertion to ADDR Hold Time | 0.4 | — |
| | WR Deassertion to DATA Hold Time | 0.5 | — |
| | WR Deassertion to CSx Hold Time | 1.2 | — |
| | WR Deassertion to IORQ Hold Time | 0.5 | — |

Note: *At the conclusion of a Write cycle, deassertion of WR always occurs before any change to ADDR, DATA, CSx, or IORQ.



Wait State Timing for Read Operations

Figure 68 illustrates the extension of the memory access signals using a single WAIT state for a Read operation. This wait state is generated by setting CS_WAIT to 001 in the Chip Select Control Register.

www.DataSheet4U.com

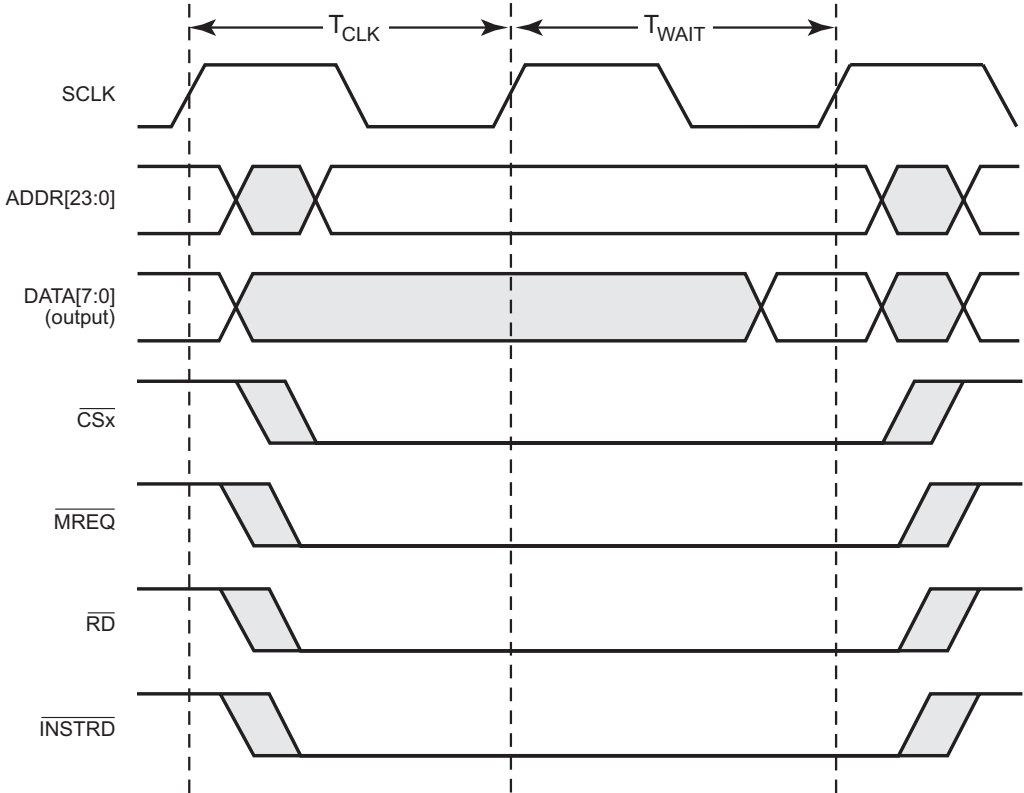

Figure 68. Wait State Timing for Read Operations



Wait State Timing for Write Operations

Figure 69 illustrates the extension of the memory access signals using a single WAIT state for a Write operation. This wait state is generated by setting CS_WAIT to 001 in the Chip Select Control Register.

www.DataSheet4U.com

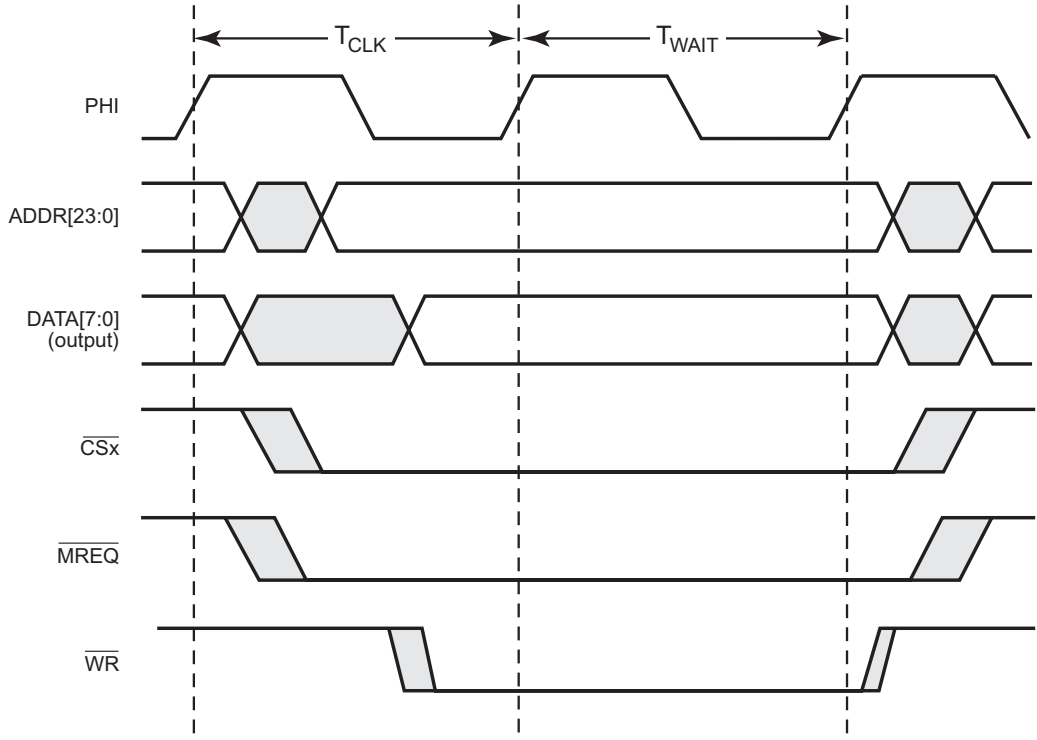

Figure 69. Wait State Timing for Write Operations



General Purpose I/O Port Input Sample Timing

Figure 70 illustrates timing of the GPIO input sampling. The input value on a GPIO port pin is sampled on the rising edge of the system clock. The port value is then available to the CPU on the second rising clock edge following the change of the port value.

www.DataSheet4U.com

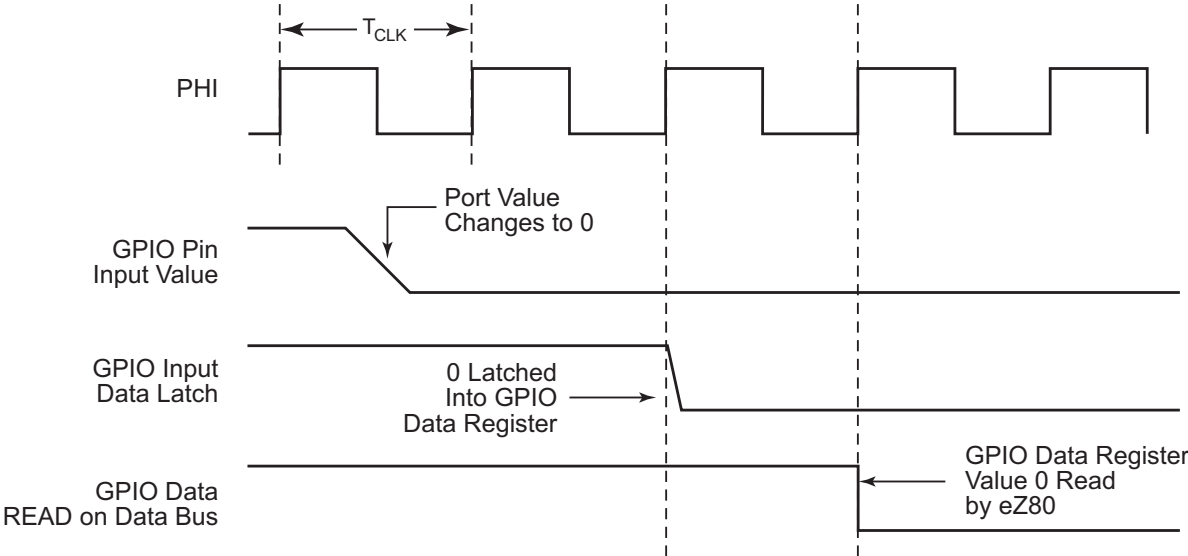

Figure 70. Port Input Sample Timing

General Purpose I/O Port Output Timing

Figure 71 and Table 240 provide timing information for GPIO port pins.

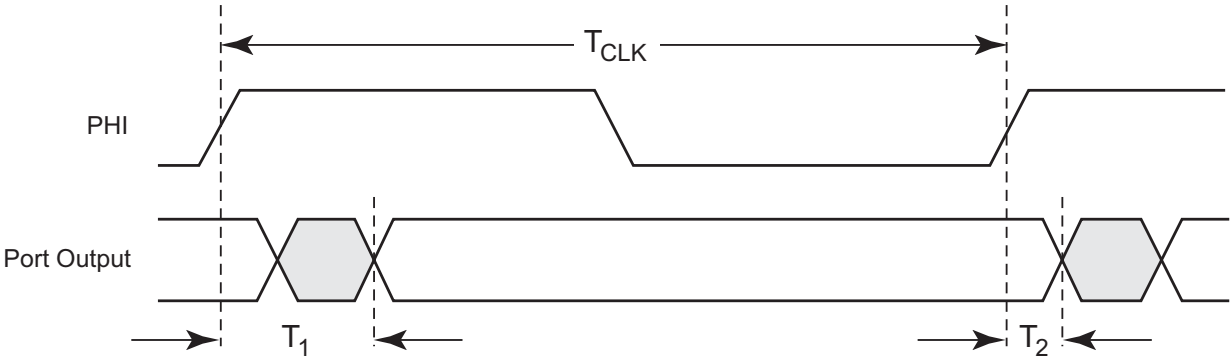

Figure 71. GPIO Port Output Timing



Table 240. GPIO Port Output Timing

| Parameter | Abbreviation | Delay (ns) | |
|----------------|---|------------|-----|
| | | Min | Max |
| T ₁ | PHI Clock Rise to Port Output Valid Delay | — | 9.3 |
| T ₂ | PHI Clock Rise to Port Output Hold Time | 2.0 | — |

www.DataSheet4U.com

External Bus Acknowledge Timing

Table 241 provides information on the bus acknowledge timing.

Table 241. Bus Acknowledge Timing

| Parameter | Abbreviation | Delay (ns) | |
|----------------|---|------------|-----|
| | | Min | Max |
| T ₁ | PHI Clock Rise to <u>BUSACK</u> Assertion Delay | 2.8 | 7.1 |
| T ₂ | PHI Clock Rise to <u>BUSACK</u> Deassertion Delay | 2.5 | 6.5 |

External System Clock Driver Timing

Table 242 provides timing information for the PHI pin. The PHI pin allows external peripherals to synchronize with the internal system clock driver on the eZ80F91 device.

Table 242. PHI System Clock Timing

| Parameter | Abbreviation | Delay (ns) | |
|----------------|----------------------------|------------|-----|
| | | Min | Max |
| T ₁ | PHI Clock Rise to PHI Rise | 1.6 | 4.6 |
| T ₂ | PHI Clock Fall to PHI Fall | 1.8 | 4.3 |



Packaging

Figure 72 illustrates the 144-pin LQFP (low-profile quad flat pack) package for the eZ80F91 device.

www.DataSheet4U.com

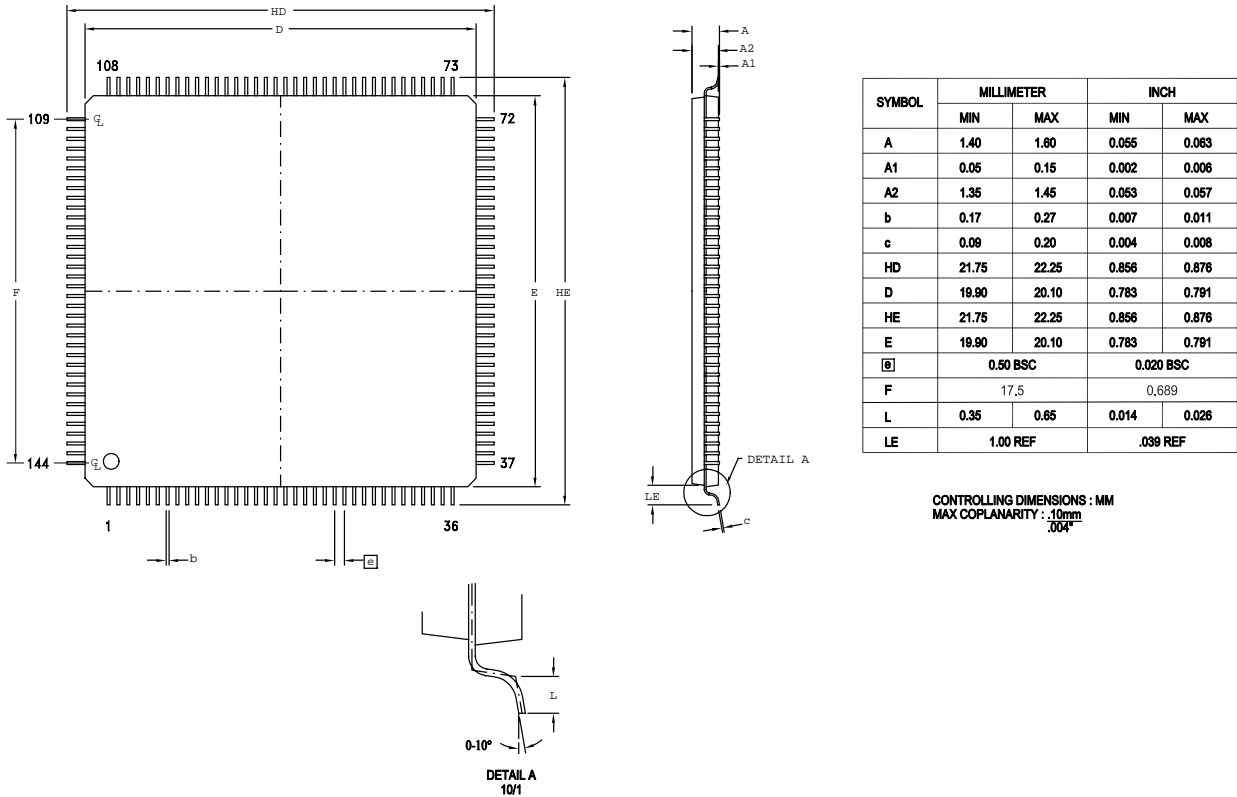

Figure 72. 144-Lead Plastic Low-Profile Quad Flat Package (LQFP)

Figure 73 illustrates the 144-pin BGA (chip array Ball Grid Array) package for the eZ80F91 device.

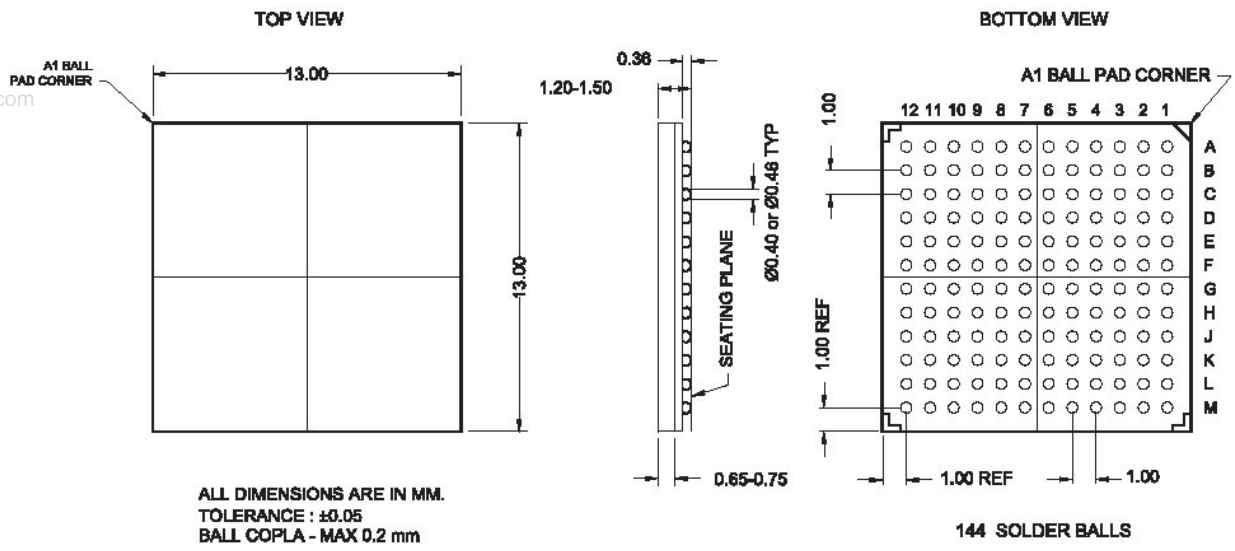

Figure 73. 144-Lead Chip Array Ball Grid Array (BGA)



Ordering Information

Table 243 provides a part name, a product specification index code, and a brief description of each part.

Table 243. Ordering Information

| Part | PSI | Description |
|-------------------------|----------------|--|
| eZ80F91 | eZ80F91AZ050SC | 144-pin LQFP, 256KB Flash memory, 8KB SRAM, 50MHz, Standard Temperature. |
| | eZ80F91AZ050EC | 144-pin LQFP, 256KB Flash memory, 8KB SRAM, 50MHz, Extended Temperature. |
| eZ80F91 | eZ80F91NA050SC | 144-pin BGA, 256KB Flash memory, 8KB SRAM, 50MHz, Standard Temperature. |
| | eZ80F91NA050EC | 144-pin BGA, 256KB Flash memory, 8KB SRAM, 50MHz, Extended Temperature. |
| eZ80F91 Development Kit | eZ80F910200ZCO | Complete Development Kit. |

Navigate your browser to ZiLOG's website to order the [eZ80F91](#) microcontroller. Or, contact your local [ZiLOG Sales Office](#). ZiLOG provides additional assistance on its [Customer Service](#) page, and is also here to help with [Technical Support](#) issues.

For ZiLOG's valuable [development tools](#) and downloadable [software](#), visit the [ZiLOG website](#).

Part Number Description

ZiLOG part numbers consist of a number of components, as indicated in the following examples:

| ZiLOG Base Products | |
|---------------------|-----------------------------|
| eZ80 | ZiLOG eZ80 [®] CPU |
| F91 | Product Number |
| AZ | Package |
| 050 | Speed |
| S or E | Temperature |
| C | Environmental Flow |



| | |
|----------------------|----------------------------------|
| Package | AZ = LQFP (also called the VQFP) |
| Speed | 050 = 50 MHz |
| Standard Temperature | S = 0°C to +70°C |
| Extended Temperature | E = -40°C to +105°C |
| Environmental Flow | C = Plastic Standard |

Example: Part number eZ80F91AZ050SC is an eZ80F91 product in a LQFP package, operating with a 50-MHz external clock frequency over a 0°C to +70°C temperature range and built using the Plastic Standard environmental flow.

Precharacterization Product

The product represented by this document is newly introduced and ZiLOG has not completed the full characterization of the product. The document states what ZiLOG knows about this product at this time, but additional features or nonconformance with some aspects of the document might be found, either by ZiLOG or its customers in the course of further application and characterization work. In addition, ZiLOG cautions that delivery might be uncertain at times, due to start-up yield issues.

ZiLOG, Inc.
532 Race Street
San Jose, CA
95126-3432
USA
Telephone (408) 558-8500
FAX 408 558-8300
Internet: www.zilog.com

Document Information

Document Number Description

The Document Control Number that appears in the footer on each page of this document contains unique identifying attributes, as indicated in the following table:

| | |
|------|--------------------------|
| PS | Product Specification |
| 0192 | Unique Document Number |
| 09 | Revision Number |
| 0504 | Month and Year Published |

Change Log

| Rev | Date | Purpose | By |
|-----|-------|-----------------------|---|
| 01 | 12/02 | Original issue | J. Eversmann, B. Metzler, R. Beebe |
| 02 | 01/03 | Minor content changes | B. Metzler, R. Beebe |
| 03 | 02/03 | Minor content changes | P. Clark, R. Beebe |
| 04 | 02/03 | Minor content changes | R. Beebe |
| 05 | 03/03 | Modified INT_P0:5 | B. Metzler, R. Beebe |
| 06 | 06/03 | Minor modifications | B. Metzler, R. Beebe |
| 07 | 07/03 | Minor modifications | C. Bender, R. Beebe |
| 08 | 10/03 | Added BGA info | C. Bender, R. Beebe |
| 09 | 05/04 | Minor content changes | R. Xue, C. Bender, B. Metzler, R. Beebe |



Index

Numerics

100-pin LQFP package 4, 5
 16-bit clock divisor value 189, 215
 16-bit divisor count 189, 215
 32 KHz Real-Time Clock Crystal Oscillator
 Operation 343

A

AAK—see I²C Acknowledge
 Absolute Maximum Ratings 345
 AC Characteristics 348
 ACK—see Acknowledge
 Acknowledge 221, 225–229, 232, 236–237
 I²C 221
 ADDR0 6
 ADDR1 6
 ADDR2 6
 ADDR3 6
 ADDR4 7
 ADDR5 7
 ADDR6 7
 ADDR7 7
 ADDR8 8
 ADDR9 8
 ADDR10 8
 ADDR11 8
 ADDR12 9
 ADDR13 9
 ADDR14 9
 ADDR15 9
 ADDR16 10
 ADDR17 10
 ADDR18 10
 ADDR19 10
 ADDR20 11
 ADDR21 11
 ADDR22 11
 ADDR23 11

address bus 6–11, 66, 76, 78–79, 82–83, 86,
 89–90, 93–94, 168, 293–294, 303, 309
 24-bit 35
 Addressing, I²C 231
 alarm bit flag 167, 181
 alarm condition 167–168, 181
 AND/OR Gating of the PWM Outputs 153–154
 Arbiter, EMAC 242
 Arbitration, I²C 223
 Architectural Overview 1
 asynchronous communications protocol 183–
 184
 asynchronous serial data 17, 20–21

B

Basic Timer Operation 128
 Basic Timer Register Set 136
 Baud Rate Generator 188
 Functional Description 213
 BCD—see Binary-Coded-Decimal Operation
 binary operation 166
 Binary-Coded-Decimal Operation 166, 168–
 179, 181
 bit generation 183–184
 Block Diagram 2
 Boot Block 33, 105, 115, 117
 Boundary Scan Cell Functionality 314
 Boundary Scan Instructions 319
 Boundary-Scan Architecture 311
 break detection 183, 193
 Break Point Halting 132
 break point trigger functions 311
 BRG Control Registers 189
 bus acknowledge 15, 78, 98, 293–294, 302–
 303, 309, 358
 cycle 6–9, 11, 14–15, 78, 98–100, 102
 Bus Arbiter 98
 Bus Arbitration Overview 219
 Bus Clock Speed, I²C 239



Bus Mode Controller 78
 bus mode state 79–80, 83
 bus modes 78–79, 92, 96
 Switching Between 92
 bus request 15, 78, 98, 293, 302, 309
 Bus Requests During ZDI Debug Mode 293
 bus timing 78
 BUSACK—see bus acknowledge
 BUSREQ—see bus request
 Byte Format, I²C 221

C

C source-level debugging 286
 capture flag 134
 carrier sense 255, 259–260
 Window Referencing 260
 MII 30, 259
 Chain Sequence and Length, JTAG Boundary Scan 314
 Change Log 363
 Characteristics, Electrical
 Charge Pump 320, 325
 PLL 321
 Chip Select Registers 93
 Chip Select x Bus Mode Control Register 96
 Chip Select x Control Register 95
 Chip Select x Lower Bound Register 93
 Chip Select x Upper Bound Register 94
 Chip Select/Wait State Generator block 6–8, 10–11
 Chip Selects and Wait States 73
 Chip Selects During Bus Request/Bus Acknowledge Cycles 78
 Clear To Send 18, 21, 199, 202
 Delta Status Change Of 202
 CLK_MUX 325
 clock divisor value, 16-bit 189, 215
 clock initialization circuitry 312
 Clock Peripheral Power-Down Registers 55
 Clock Phase 210–212, 216
 Clock Polarity 211–212, 216
 Clock Synchronization for Handshake 224
 Clock Synchronization, I²C 222

Clocking Overview 219
 COL—see Collision Detect, MII
 Collision Detect, MII 30
 Complex triggers 311
 CONTINUOUS mode 127, 130–132, 139, 143–144
 Control Transfers, UART 187
 CPHA—see Clock Phase
 CPOL—see Clock Polarity
 CRC—see cyclic redundancy check 246–247, 251–252, 264
 CRS—see Carrier Sense, MII
 CS0 11, 73–76
 CS1 12, 73–76
 CS2 12, 73, 75–76
 CS3 12, 73, 75–76
 CTS—see Clear To Send
 CTS0 18, 206
 CTS1 21
 Customer Feedback Form 379
 cycle termination signal 89–90

D

data bus 12, 78–79, 81–83, 86, 90, 96, 168, 293–294, 303, 309
 Data Carrier Detect 19, 22, 199, 202
 Delta Status Change Of 202
 Data Set Ready 19, 22, 199, 202
 Delta Status Change Of 202
 Data Terminal Ready 18, 22, 199, 202
 Data Transfer Procedure with SPI configured as a Slave 214
 Data Transfer Procedure with SPI Configured as the Master 214
 data transfer, SPI 217
 Data Transfers, UART 187
 Data Validity, I²C 220
 DATA0 12
 DATA1 12
 DATA2 12
 DATA3 12
 DATA4 13
 DATA5 13



DATA6 13
 DATA7 13
 DC Characteristics 346
 DCD—see Data Carrier Detect
 DCD0 19, 206
 DCD1 22
 DCTS—see Clear To Send, Delta Status
 Change Of
 DDCD—see Data Carrier Detect, Delta Status
 Change Of
 DDSR—see Data Set Ready, Delta Status
 Change Of
 Divider, PLL 321
 divisor count 215
 16-bit 189
 Document Information 363
 Document Number Description 363
 DSR—see Data Set Ready
 DSR0 19, 206
 DSR1 22
 DTACK—see cycle termination signal
 DTR—see Data Terminal Ready
 DTR0 18, 206
 DTR1 22

E

EC0 23, 133, 136, 138
 EC1 30, 133, 135, 138
 edge-selectable interrupts 62
 Edge-Triggered Interrupts 60, 62
 Electrical Characteristics 345
 EMAC—see Ethernet Media Access Controller
 EMACMII module 240
 Enabling and Disabling the WDT 123
 encoder/decoder 204–205, 207–208
 signal pins 206
 IrDA 56
 endec—see encoder/decoder
 ENDEC Mode 254, 258
 Erasing Flash Memory 109
 Ethernet Media Access Controller 240
 Address Filter Register 263

Boundary Pointer Register—Low and High
 Bytes 271
 Boundary Pointer Register—Upper Byte
 272
 Buffer Size Register 274
 Configuration Register 1 251
 Configuration Register 2 253
 Configuration Register 3 254
 Configuration Register 4 255
 FIFO Data Register—Low and High Bytes
 284
 FIFO Flags Register 285
 Functional Description 241
 functions 240
 Hash Table Register 264
 Interpacket Gap 258
 Interpacket Gap Register 259
 Interrupt Enable Register 275
 Interrupt Status Register 277
 Interrupts 244
 Maximum Frame Length Register—Low
 and High Bytes 261
 memory 241, 242
 MII Management Register 265
 MII Status Register 279
 Non-Back-To-Back IPG Register—Part 1
 260
 Non-Back-To-Back IPG Register—Part 2
 261
 PHY Address Register 267
 PHY Configuration Data Register—High
 Byte 267
 PHY Configuration Data Register—Low
 Byte 266
 PHY Read Status Data Register—Low and
 High Bytes 278
 PHY Unit Select Address Register 268
 RAM 101–104
 Receive Blocks Left Register—Low and
 High Bytes 282
 Receive High Boundary Pointer Register—
 Low and High Bytes 272
 Receive Read Pointer Register—Low and
 High Bytes 273

Receive Write Pointer Register—High Byte 281
 Receive Write Pointer Register—Low Byte 280
 Receiver Interrupts 244
 Registers 249
 Reset Control Register 269
 Shared Memory Organization 245
 Station Address Register 256
 sublayer module 240
 System Interrupts 244
 Test Register 249
 Transmit Lower Boundary Pointer Register—Low and High Bytes 270
 Transmit Pause Timer Value Register—Low and High Bytes 257
 Transmit Polling Timer Register 268
 Transmit Read Pointer Register—High Byte 282
 Transmit Read Pointer Register—Low Byte 281
 Transmitter Interrupts 244
 event count input 138
 event count mode 134
 event counter 131, 133
 External Bus Acknowledge Timing 358
 external bus master 98–99
 external bus request 78, 289, 293
 External I/O Read Timing 352
 External I/O Write Timing 353
 External Memory Read Timing 349
 External Memory Write Timing 350
 external pull-down resistor 59
 External Reset Input and Indicator 51
 External System Clock Driver (PHI) Timing 358
 eZ80 Bus Mode 79, 96
 eZ80 CPU 14, 77–78, 82, 89, 204, 296, 311
 Core 50
 Instruction Set 330
 eZ80 Product ID Low and High Byte Registers 305
 eZ80 Product ID Revision Register 306
 eZ80Acclaim!™ Flash Microcontrollers 1, 106
 eZ80F91 device 4–5, 35, 347

F

falling edge 152–153, 155, 160
 FAST mode 219, 239
 FCS—see frame check sequence
 Features 1
 Features, eZ80 CPU Core 50
 FIFO mode 184, 187
 Flash Address registers 107–108, 111, 118
 Flash Address Upper Byte Register 112
 Flash Column Select Register 120
 Flash Control Register 110, 113
 Flash controller 106–108, 114, 116
 clock 114
 Flash Data Register 111
 Flash Frequency Divider Register 114
 Flash Interrupt Control Register 116
 Flash Key Register 110
 Flash Memory 105
 Arrangement in the eZ80F91 Device 105
 array 106, 118
 Overview 106
 Flash Page Select Register 118
 Flash Program Control Register 120
 Flash Row Select Register 119
 Flash Write/Erase Protection Register 115
 frame check sequence 247–248, 258
 framing error 183, 185, 193, 200
 frequency divider 106, 114
 full-duplex transmission 212
 Functional Description, Infrared Encoder/Decoder 204
 Functional Description, SPI 212

G

General Purpose Input/Output 58
 Control Registers 62
 Interrupts 61
 modes 59–60
 Operation 58
 Port Input Sample Timing 357
 Port Output Timing 357
 port pins 51, 58, 63, 357
 GND—see Ground

GPIO—see General Purpose Input/Output
Ground 2

H

HALT instruction 16, 54, 307, 333
Op-Code Map 335
HALT Mode 1, 54–55, 299, 307
HALT_SLP 16, 307, 314
handshake 183, 185, 224
hash table 263

I

I/O Chip Select Operation 76
I/O Chip Selects, External 35
I/O Read 107
I/O space 6–8, 10–11, 13, 73, 76
I²C Acknowledge 221, 225–226, 228–231,
234–235
I²C bus 219, 222–224
clock 219
protocol 220
I²C Clock Control Register 238
I²C control bit 225–226, 228
I²C Control Register 234
I²C Data Register 233
I²C Extended Slave Address Register 232
I²C General Characteristics 219
I²C Interrupt Flag 219, 224, 227, 229–232,
234, 237
I²C Registers 231
I²C Serial Clock 26, 219–221, 238
I²C Serial I/O Interface 219
I²C Slave Address Register 232
I²C Software Reset Register 239
I²C Status Register 236
IC0 23, 133, 136, 140–141, 144–147, 157, 161
IC1 24, 133, 136, 140–141, 144, 146, 157, 161
IC2 25, 133, 136, 140–141, 144–146, 157, 161
IC3 25, 133, 136, 140–141, 144, 146–147,
157, 161

IEEE 1149.1 specification 313, 319

IEEE 802.3 specification 253–254, 263
frames 252
IEEE 802.3, 802.3(u) minimum values 258
IEEE 802.3/4.2.3.2.1 Carrier Deference 259–
260
IEEE Standard 1149.1 311–312
IEF1 67–68, 131, 307
IEF2 67–68
IFLG—see I²C Interrupt Flag
IM 0, Op Code Map 338
IM 1, Op Code Map 338
IM 2, Op Code Map 338
Information Page Characteristics 110
Infrared Data Association 204
Receive Data 17
specifications 205
standard 204
standard baud rates 204
transceiver 207
Transmit Data 17
Infrared Encoder/Decoder 17, 56, 204, 207
Register 207
Signal Pins 206
Input capture mode 133–134, 136, 140
Input/Output Request 13, 15, 76, 79, 82–83, 86
Assertion Delay 352, 354
Deassertion Delay 353–354
Hold Time 354
INSTRD—see Instruction Read
Instruction Read 14
Instruction Store 4
0 Registers 303
Intel Bus Mode 81
Separate Address and Data Buses 82
internal pull-up 59
Internal RC oscillator 122–123, 125
internal system clock 77
interpacket gap 247, 258–259, 261
Interrupt Controller 65
Interrupt Enable bit 15, 167, 186, 234
Interrupt Enable Flag 131, 307
interrupt input 17–19, 21–22, 24–27, 29, 207
Interrupt Priority 69, 71
levels 68



Registers 68
 Interrupt request 60–62, 66, 117, 133, 139–140
 enable 213, 216
 signals 65
 interrupt service routine 66–68
 SPI 66
 interrupt sources 157
 interrupt vector 65–66
 address 67, 68
 bus 65–68
 locations 66
 table 67
 interrupt, higher-priority 71, 194
 interrupt, highest-priority 65–66
 interrupts, edge-selectable 62
 interrupts, level-sensitive 62
 Introduction to On-Chip Instrumentation 311
 Introduction, ZiLOG Debug Interface 286
 IORQ—see Input/Output Request
 IR_RXD modulation signal 205–208
 IR_TxD modulation signal 17, 205–207
 IrDA—see Infrared Data Association 204
 IRQ—see interrupt request
 IRQ_EN—see interrupt request enable
 ISR—see interrupt service routine
 IVECT—see interrupt vector bus

J

Jitter, Infrared Encoder/Decoder 206
 Joint Test Action Group 313
 Boundary Scan 313
 interface 311, 319
 mode selection 312
 Test Clock 288, 312–313, 319
 Test Data In 312–314
 Test Data Out 312–314
 Test Mode 16
 Test Mode Select 312–313
 JTAG—see Joint Test Action Group

L

least-significant bit 142–143, 145–146, 149, 162, 164, 224–228, 230, 262, 266, 270, 272–273, 278, 280–281
 least-significant byte 66–68, 143, 238, 243, 256, 263
 level-sensitive interrupt modes 60
 level-sensitive interrupts 62, 207
 Level-Triggered Interrupts 61
 Line break detection 183
 line status error 186
 line status interrupt 185, 187–188, 193
 Lock Detect 320, 322
 sensitivity 325
 PLL 322
 Loop Filter 320, 322, 329
 PLL 20, 321
 LOOP Mode 185
 LOOP_FILT 313
 Loopback Testing, Infrared Encoder/Decoder 207
 low-byte vector 65
 Low-Power Modes 54
 LSB—see least-significant byte
 lsb—see least-significant bit

M

maskable interrupt 55, 65, 68, 71
 MASS ERASE operation 109–110, 115–116, 118, 120–121
 MASTER mode 211, 219, 230, 234–239
 Start bit 234
 Stop bit 234
 SPI 212
 MASTER RECEIVE Mode 219, 227
 MASTER TRANSMIT Mode 219, 224
 MASTER_EN bit 213
 Master-In, Slave-Out 25, 210, 212
 Master-Out, Slave-In 26, 210–212
 MAXF—see Maximum Frame Length
 Maximum Frame Length 251, 261
 MBIST—see Memory Built-In Self-Test controllers



MDC—see Media-Independent Interface Management Data Clock
 MDIO—see Media-Independent Interface Management Data
 Media-Independent Interface 240, 244, 258, 265, 276–279
 Collision Detect 30
 Management Data 33
 Management Data Clock 33, 266
 Memory and I/O Chip Selects 73
 Memory Built-In Self-Test controllers 104
 Memory Chip Select Example 74
 Memory Chip Select Operation 73
 Memory Chip Select Priority 74
 Memory Read 107
 Memory Request 14
 memory space 73, 76
 Memory Write 109
 Memory, EMAC 241
 MII—see Media-Independent Interface
 MISO—see Master-In, Slave-Out
 Mode fault error flag 210, 213, 217
 modem status 186–188, 194, 198, 202
 interrupt 206
 signal 18–19, 21–22
 MODF—see Mode fault error flag
 Module Reset, UART 187
 MOSI—see Master-Out, Slave-In
 most significant bit 118, 143–144, 146–147, 150, 163, 165, 221, 262, 270, 279, 281–283, 292
 most significant byte 67, 144, 243
 Motorola Bus Mode 88
 Motorola-compatible 78
 MPWM_EN 151, 158
 MREQ—see Memory Request 14–15, 74, 79, 82–83, 86, 349, 351
 Hold Time 351
 MSB—see most significant byte
 msb—see most significant bit
 Multibyte I/O Write (Row Programming) 108
 multicast address 248, 264
 multicast packet 263, 264
 multimaster conflict 213, 217

Multi-PWM Control Registers 158
 Multi-PWM Mode 150
 Multi-PWM Power-Trip Mode 157
 MUX/CLK Sync 320
 PLL 321

N

NACK—see Not Acknowledge
 New Instructions, eZ80 CPU Core 50
 NMI—see Nonmaskable Interrupt
 NMI_flag bit 124
 NMI_OUT bit 124
 Nonmaskable Interrupt 15, 50, 55, 65, 122, 124, 333
 nonoverlapping delay, PWM 153, 156
 Not Acknowledge 221, 225–226, 228–229, 235, 237

O

OC0 27, 133, 135, 140–141, 148–150
 OC1 27, 133, 135, 140–141
 OC2 28, 133, 135, 140,–141
 OC3 28, 133, 135, 139, 141, 149–150
 OCI—see On-Chip Instrumentation
 On-Chip Instrumentation 311
 Activation 312
 clock pin 312
 Interface 312
 Introduction to 311
 On-Chip Oscillators 342
 on-chip pull-up 346
 on-chip RAM 73, 101–102
 Op Code maps 335
 Open source I/O 59
 open-drain I/O 59
 open-drain mode 59
 open-drain output 59, 219
 open-source mode 59
 open-source output 17–19, 21–23, 25–27, 29, 59
 Operating Modes, I²C 224
 Operation of the eZ80F91 Device during ZDI



Break Points 293
 Ordering Information 361
 OUTPUT COMPARE mode 133, 134, 137,
 139, 148
 overrun condition, receiver 186
 overrun error 183, 185, 193, 201
 Overview, Low-Power Modes 54
 Overview, Phase-Locked Loop 320

P

PA7 155
 Packaging 359
 Page Erase operation 109, 118, 120, 121
 PAIR_EN 158–159
 parity error 185, 196, 201
 Part Number Description 361
 PB0 23
 PB1 24
 PB2 24
 PB3 24
 PB4 25
 PB5 25
 PB6 25
 PB7 26
 PC0 20, 27
 PC1 21, 27
 PC2 21, 28
 PC3 21, 28
 PC4 22, 29
 PC5 22, 29
 PC6 22, 30
 PC7 23, 30
 PD0 17, 207
 PD1 17, 207
 PD2 18, 207
 PD3 18
 PD4 18
 PD5 19
 PD6 19
 PD7 19, 207
 Phase Frequency Detector 320
 PLL 321
 Phase-Locked Loop 320
 PHI—see system clock output
 PHY—see Physical Layer, OSI Model
 MII 240, 265
 Physical Layer, OSI Model 6, 30–31, 32, 37–
 38, 244, 248, 266–267, 277–279
 Pin Characteristics 6
 Pin Coverage, JTAG Boundary Scan 313
 Pin Description 4
 PLL Characteristics 327
 PLL Control Register 0 325
 PLL Control Register 1 326
 PLL Divider Control Register—Low and High
 Bytes 323
 PLL Loop Filter 20
 PLL Normal Operation 322
 PLL Registers 323
 PLL_V_{DD} 323
 PLL_V_{SS} 323
 Poll Mode Transfers 188
 POP, Op Code Map 335, 337, 339
 POR—see Power-On Reset
 Port A 27, 28, 29, 56, 58, 66, 70, 71, 150
 Port x Alternate Register 1 63
 Port x Alternate Register 2 64
 Port x Data Direction Registers 63
 Port x Data Registers 62
 Potential Hazards of Enabling Bus Requests
 During Debug Mode 294
 Power connections 2
 Power-On Reset
 Power Requirement to the Phase-Locked Loop
 Function 323
 Power-On Reset 51–52, 347
 and VBO Electrical Characteristics 347
 and VBO analog RESET duration 347
 and VBO DC current consumption 347
 and VBO Hysteresis 347
 voltage threshold 52, 347
 Power-Trip Mode, Multi-PWM 157–158
 Precharacterization Product 362
 Primary Crystal Oscillator Operation 342
 Program Counter 51, 54–55, 67, 105, 304–
 305, 309
 Program Counter, Starting 68



Programmable Reload Timers 127
 Programming Flash Memory 107
 PROMISCUOUS Mode 263
 PT_EN 158
 pull-up resistor, external 59, 219
 Pulse-Width Modulation
 Control Register 1 158
 Control Register 2 159
 Control Register 3 161
 delay feature 156
 edge transition values 153–154
 Falling Edge—High Byte 165
 Falling Edge—Low Byte 164
 generator 150–154, 158
 generators 151
 Master Mode 153
 mode 127, 133, 137, 140
 mode, Multi- 150–151, 153–154, 158
 nonoverlapping delay 153
 nonoverlapping delay time 156
 Nonoverlapping Output Pair Delays 155
 output pairs 153
 outputs 154–155, 157
 Outputs, AND/OR Gating 153–154
 outputs, inverted 152
 pairs 154
 power-trip state 157
 Rising Edge—High Byte 163
 Rising Edge—Low Byte 162
 signals 150
 trip levels 161
 waveform 154
 PUSH, Op Code Map 335, 337, 339
 PWM—see Pulse-Width Modulation
 PWM0 155
 PWM1 27, 29, 133, 135, 152, 154
 PWM1 falling edge end-of-count 153, 156
 PWM1 rising edge end-of-count 153, 156
 PWM1_EN 158
 PWM1FH 153
 PWM1RH 163, 165
 PWM1RL 162–165
 PWM2 28, 30, 133, 135, 152
 PWM2 falling edge end-of-count 153

PWM2 rising edge end-of-count 153
 PWM2_EN 158
 PWM2RH 153
 PWM3 28, 30, 133, 135, 152
 PWM3_EN 158
 PWMCNTRL1 151
 PWMCNTRL2 153
 PWMCNTRL3 157

Q

qualified multicast messages 263

R

RAM—see Random Access Memory
 Random Access Memory 101
 Address Upper Byte Register 103
 Control Register 102
 RD—see Read instruction
 Read instruction 13–14, 74, 76, 79, 82–83, 86
 Assertion Delay 350, 353
 Deassertion Delay 350, 353
 Reading Flash Memory 106
 Reading the Current Count Value 128
 Real-Time Clock 51, 54, 166–168, 180
 Alarm 54, 167
 Alarm Control Register 180
 Alarm Day-of-the-Week Register 179
 Alarm Hours Register 178
 Alarm Minutes Register 177
 Alarm Seconds Register 176
 Battery Backup 167
 Century Register 175
 Control Register 181
 Day-of-the-Month Register 172
 Day-of-the-Week Register 171
 Hours Register 170
 Minutes Register 169
 Month Register 173
 Oscillator and Source Selection 167
 Overview 166
 Recommended Operation 167
 Registers 168



Seconds Register 168
 signal 134
 source 122, 125, 131
 Year Register 174
 Receive, Infrared Encoder/Decoder 205
 Recommended Usage of the Baud Rate
 Generator 189
 Register Map 35
 Register Set for Capture in Timer 1 136
 Register Set for Capture/Compare/PWM in
 Timer 3 137
 Request To Send 18, 21, 199, 202, 206
 RESET 14, 51–52, 54–55, 59, 73, 101–102,
 113, 115, 122–124, 168, 171–181, 189, 207,
 214–215, 297, 299, 312, 314, 347
 Reset controller 51–52
 RESET event 51, 58
 RESET mode timer 51–52
 Reset Operation 51
 RESET Or NMI Generation 124
 Reset States 74
 RESET_OUT 314
 Resetting the I²C Registers 231
 RI—see Ring Indicator
 RI0 19, 206
 RI1 23, 60
 Ring Indicator 19, 23, 185, 199, 202
 Trailing Edge of 202
 rising edge 152–153, 155, 160
 RST_FLAG bit 124
 RTC Oscillator Input 134
 RTC Supply Voltage 346
 RTC_V_{DD} 16
 RTC_X_{IN} 15
 RTC_X_{OUT} 15, 167
 RTS—see Request To Send
 RTS0 18
 RTS1 21
 Rx_CLK 32
 Rx_DV 32
 Rx_ER 32
 RxD0 17, 32
 RxD1 21, 32
 RxD2 32

RxD3 33
 RxDMA 243

S

Schmitt Trigger 14–15
 Input 14–16, 20, 22–23, 25, 33
 input buffers 58
 SCK—see SPI Serial Clock
 SCL—see I²C Serial Clock
 SCL line 222, 224
 SCLK—see System Clock
 SDA 26, 219, 220, 221, 231
 SDA line 223
 see system reset 13
 serial bus, SPI 217, 218
 Serial Clock 219
 Serial Clock, I²C 26, 219–221, 238
 Serial Clock, SPI 24, 210
 Serial Data 210, 219
 Serial Data, I²C 26
 Serial Peripheral Interface 1, 56, 66, 70, 209–
 210, 212
 Baud Rate Generator 213
 Baud Rate Generator Registers—Low
 Byte and High Byte 215
 Control Register 216
 Data Rate 214
 Flags 213
 Functional Description 212
 interrupt service routine 66
 master device 25–26, 214
 MASTER mode 212
 mode 24
 Receive Buffer Register 218
 Registers 214
 serial bus 217
 Signals 210
 slave device 25, 26
 SLAVE mode 212
 Status Register 217
 Status register 213
 Transmit Shift Register 213–214, 217
 Setting Timer Duration 128



- Shift Left Arithmetic 226, 228, 232, 334
 - Op Code Map 336, 340–341
 - Shift Right Arithmetic 334
 - Op Code Map 336, 340
 - SINGLE PASS Mode 127, 129–130, 139
 - Single-Byte I/O Write 107
 - SLA—see Shift Left Arithmetic
 - SLAVE mode 219, 230, 232, 234, 237
 - SLAVE mode, SPI 212
 - Slave Receive 219, 230
 - Slave Select 24, 210–212, 214, 216
 - Slave Transmit mode 219, 229–230, 235
 - SLEEP Mode 54, 181, 299, 307
 - sleep-mode recovery 181
 - reset 35, 182
 - Software break point instruction 311
 - Specialty Timer Modes 133
 - SPI—see Serial Peripheral Interface
 - SPI Serial Clock 24, 210
 - Flag 212, 217–218,
 - Idle State 211
 - pin 212, 216
 - Receive Edge 211
 - signal 212
 - Transmit Edge 211
 - SPIF—see SPI Flag
 - SRA—see Shift Right Arithmetic
 - SRAM—see Static RAM
 - SS—see Slave Select
 - STA—see MASTER Mode Start bit
 - STANDARD mode 219
 - Standard VHDL Package STD_1149_1_2001 314
 - START and STOP Conditions 220
 - START condition 220, 222–224, 226–227, 229–237, 239
 - ZDI 288
 - Starting Program Counter 67–68
 - Static RAM 1, 112, 281, 286, 361
 - internal Ethernet 245
 - STOP condition 220–221, 224, 227, 229–231, 234–235, 237, 239
 - supply voltage 2, 52, 59, 219, 322, 345–347
 - Switching Between Bus Modes 92
 - System Clock 51, 54–57, 60–61, 122–123, 125, 131, 133, 138, 155, 188, 213, 238–239, 242, 266, 320–322, 357
 - Cycle Time 348
 - cycles 14, 76, 79–80, 83, 86–87, 90, 123, 128, 312
 - divider 139
 - driver 358
 - Driver Timing, External 358
 - Fall Time 348
 - Frequency 128, 189, 214
 - frequency 107, 109, 113–114, 287
 - High Time 348
 - jitter 134
 - Low Time 348
 - Oscillator Input 20
 - Oscillator Output 20
 - output 26, 57, 315, 358
 - period 312
 - periods 156, 160
 - Rise Time 348
 - rising edge 188, 213
 - source 325
 - Timing, PHI 358
 - system clock, high-frequency 213
 - system clock, internal 77
 - system RESET 51, 167, 169, 170, 191, 249, 322
- T**
- T2 clock 156
 - T2 end-of-count 156
 - T23CLKCN 156
 - TAP—see Test Access Port
 - TCK—see JTAG Test Clock
 - TDI—see JTAG Test Data In
 - TDO—see JTAG Test Data Out
 - TERI—see Ring Indicator, Trailing Edge of
 - Test Access Port 311, 319
 - instruction 319
 - Reset 312–313
 - state register 312
 - Test Mode 312

Time-Out Period Selection 123
Timer Control Register 138
Timer Data Register—High Byte 142
Timer Data Register—Low Byte 142
Timer Input Capture Control Register 144
Timer Input Capture Value A Register—High Byte 146
Timer Input Capture Value A Register—Low Byte 145
Timer Input Capture Value B Register—High Byte 147
Timer Input Capture Value B Register—Low Byte 146
Timer Input Source Selection 131
Timer Interrupt Enable Register 139
Timer Interrupt Identification Register 141
Timer Interrupts 130
Timer Output 131
 Compare Control Register 1 147
 Compare Control Register 2 148
 Compare Value Register—High Byte 150
 Compare Value Register—Low Byte 149
Timer Port Pin Allocation 135
Timer Registers 136
Timer Reload Register—High Byte 144
Timer Reload Register—Low Byte 143
TMS—see JTAG Test Mode Select
TOUT0 29, 135
TOUT1 29, 135
Trace buffer memory 311
Trace history buffer 311
Transferring Data 221
transmit shift register 184, 192, 196, 200
Transmit Shift Register, SPI 212–214, 217–218
Transmit, Infrared Encoder/Decoder 205
trigger-level detection logic 184
TRIGOUT 312, 314
tristate 157
TRSTn—see Test Access Port Reset
Tx_CLK 31
Tx_EN 31
Tx_ER 31
TxD0 17, 31

TxD1 20, 31
TxD2 31
TxD3 31
TxDMA 242

U

UART—see Universal Asynchronous Receiver/Transmitter
Universal Asynchronous Receiver/Transmitter 183
 Baud Rate Generator Register—Low and High Bytes 189
 FIFO Control Register 195
 Functional Description 184
 Functions 184
 Interrupt Enable Register 192
 Interrupt Identification Register 193
 Interrupts 186
 Line Control Register 196
 Line Status Register 200
 Modem Control 185
 Modem Control Register 198
 Modem Status Interrupt 187
 Modem Status Register 202
 Receive Buffer Register 192
 Receiver 185
 Receiver Interrupts 186
 Recommended Usage 187
 Registers 191
 Scratch Pad Register 203
 Transmit Holding Register 191
 Transmitter 184
 Transmitter Interrupt 186
Usage, JTAG Boundary Scan 319

V

VBO—see Voltage Brown-Out
V_{CC}—see supply voltage
V_{CC} ramp rate 347
VCO—see Voltage Controlled Oscillator
VLAN tagged frame 261
Voltage Brown-Out 51–53, 347



pulse reject period 347
Reset 52
Voltage Threshold 347
Voltage Controlled Oscillator 321, 328
PLL 321
voltage signal, high 108
voltage, input 321
voltage, peak-to-peak 329
voltage, supply 2, 59, 219, 322, 345, 346

W

WAIT 1, 14, 83, 86, 89–90, 120
WAIT Input Signal 77
WAIT pin, external 79
Wait State Timing for Read Operations 355
Wait State Timing for Write Operations 356
WAIT states 66, 76, 80, 87, 83, 86, 95, 294, 355–356
Watch-Dog Timer 1, 51, 54, 122–124, 293
clock source 122–123, 125
Control Register 35, 124
Operation 123
oscillator 124
Overview 122
Registers 124
Reset Register 126
time-out 51, 54–55, 122–126
time-out reset 35
WCOL—see Write Collision
WDT—see Watch-Dog Timer
WP—see Write Protect pin
WR—see Write instruction
Write Collision 212–213, 217
SPI 217
Write instruction 13–14, 74, 76, 79, 83, 86, 351, 354
Write Protect pin 33, 105, 115, 117

X

X_{IN} input pin 342
X_{OUT} output pin 342

Z

Z80 Bus Mode 79
ZCL—see ZiLOG Debug Interface Clock
ZDA—see ZiLOG Debug Interface Data
ZDI—see ZiLOG Debug Interface
ZDI_BUS_STAT 294, 296, 309
ZDI_BUSACK_EN 293, 309
ZDI-Supported Protocol 287
ZDS II—see ZiLOG Developer Studio II
ZiLOG Debug Interface 286–287, 311
Address Match Registers 296
Block Read 292
Block Write 291
Break Control Register 297
Bus Control Register 302
Bus Status Register 309
Clock 288, 291, 297
lock and Data Conventions 288
clock pin 288
Data 288, 297, 312
data pin 288
debug control 311
Master Control Register 299
Read Memory Register 309
Read Operations 292
Read Register Low, High, and Upper 308
Read/Write Control Register 300
Read-Only Registers 295
Register Addressing 290
Register Definitions 296
Single-Bit Byte Separator 289
Single-Byte Read 292
Single-Byte Write 291
Start Condition 288
Status Register 307
Write Data Registers 300
Write Memory Register 304
Write Only Registers 294
Write Operations 291
ZiLOG Developer Studio II 286



Customer Feedback Form

The eZ80F91 Product Specification

If you experience any problems while operating this product, or if you note any inaccuracies while reading this Product Specification, please copy and complete this form, then mail or fax it to ZiLOG (see *Return Information*, below). We also welcome your suggestions!

Customer Information

| | |
|----------------|---------|
| Name | Country |
| Company | Phone |
| Address | Fax |
| City/State/Zip | Email |

Product Information

| |
|--------------------------------|
| Serial # or Board Fab #/Rev. # |
| Software Version |
| Document Number |
| Host Computer Description/Type |

Return Information

ZiLOG
System Test/Customer Support
532 Race Street
San Jose, CA 95126
Phone: (408) 558-8500
Fax: (408) 558-8536
Email: tools@zilog.com

Problem Description or Suggestion

Provide a complete description of the problem or your suggestion. If you are reporting a specific problem, include all steps leading up to the occurrence of the problem. Attach additional pages as necessary.
