

EDE1400 Serial to Parallel-Printer Interface IC

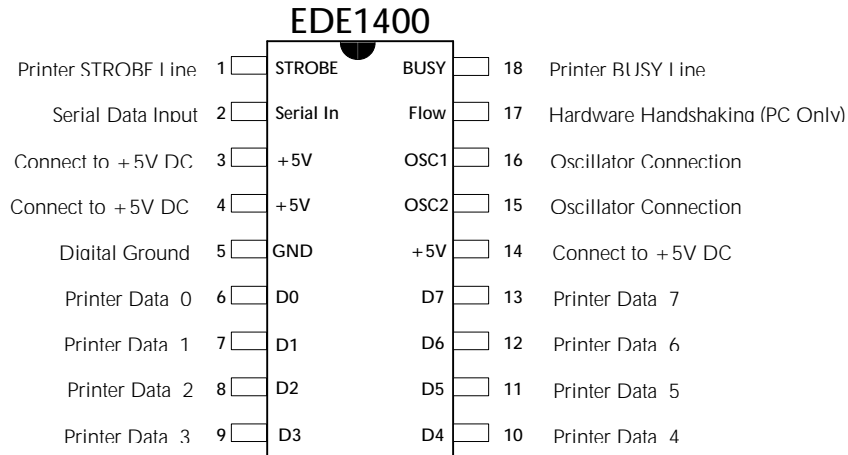

The EDE1400 Serial to Parallel-Printer (Centronics) converter IC is designed to allow printing on most parallel-interface printers via microcontrollers and BASIC Stamps™. It allows such devices the ability to create hard-copy output of data or status without the intervention of a PC and without the I/O or timing demands of the printer's parallel interface. Typical applications include data logging, status reports, parameter graphing, etc. Data is written to the EDE1400 over a single serial data wire at 2400 Baud. The EDE1400 generates the appropriate printer control signals as well as monitors printer status to cause the incoming serial stream to be printed on the parallel printer, thus allowing designers the ability to use the less-expensive and more readily available parallel-type printers as opposed to the more costly serial-input printers. The EDE1400 can also be used with most PC's, allowing data to be sent to most parallel printers over a single serial wire; hardware handshaking signals are also generated by the EDE1400 to allow it to communicate properly with the PC. Connection to most microcontrollers, stamps, or microprocessors can be made using a single data wire, without any type of voltage level conversion.

Some of the special features of the EDE1400 are as follows:

- *Directly receives RS-232 data from microcontrollers or Stamps*
- *Single-chip design is ideal for embedded designs*
- *Prints any ASCII character on most Centronics/Parallel type printers*
- *Monitors printer status for reliable operation*
- *Allows printed data to be sent over a single wire*
- *Internal watchdog timer allows for trouble-free operation*
- *Operates from single +5V supply*
- *2400 Baud serial input data rate (2400 N-8-1)*
- *Available in 18 pin DIP or SOIC packages*

PIN DEFINITIONS

Printer Connection Pins

STROBE (Pin 1):	Printer STROBE Line; pin 1 on parallel printer cable
BUSY (Pin 18):	Printer BUSY Line; pin 11 on parallel printer cable
D0 (Pin 6):	Printer Data 0 Line; pin 2 on parallel printer cable
D1 (Pin 7):	Printer Data 1 Line; pin 3 on parallel printer cable
D2 (Pin 8):	Printer Data 2 Line; pin 4 on parallel printer cable
D3 (Pin 9):	Printer Data 3 Line; pin 5 on parallel printer cable
D4 (Pin 10):	Printer Data 4 Line; pin 6 on parallel printer cable
D5 (Pin 11):	Printer Data 5 Line; pin 7 on parallel printer cable
D6 (Pin 12):	Printer Data 6 Line; pin 8 on parallel printer cable
D7 (Pin 13):	Printer Data 7 Line; pin 9 on parallel printer cable
GND (Pin 5):	Printer Ground Line; pin 18 on parallel printer cable

EDE700 Control & Data Pins

Serial Input (Pin 2):	Serial Data Input
Flow Control (Pin 17):	Hardware Handshaking (Only for PC interfacing)

Clock/ Power Pins

OSC1,OSC2 (Pin 16, Pin 15):	4 MHz Resonator Connections
+5V Power (Pin 14, Pin 4, Pin 3):	Connect to +5V DC
GND (Pin 5):	Connect to 0 VDC (GND)

OVERVIEW OF USE

Operation of the EDE1400 is fairly straightforward. Text to be printed is sent serially at 2400 Baud to the EDE1400. The EDE1400 takes care of the entire printer interface protocol. For instance, printing the text "Hello World!" on your printer via the EDE1400 is done by sending the ASCII string 'Hello World' at 2400 Baud, no parity, 8 data bits, and one stop bit (N-8-1, the most popular serial format for RS-232). The text is not actually printed on the printer until the Carriage Return character (\$0D Hex, 13 Decimal) is sent. In addition, the Line Feed character (\$0A Hex, 10 Decimal) needs to be sent after each line of text to cause the printer to advance one row.

The EDE1400 requires a 4MHz resonator or crystal to operate, as illustrated in the schematic in Figure One. Serial data coming from a stamp of microcontroller can be connected directly to the

EDE1400 using only a wire; data from a PC must first go through a RS232 to TTL voltage-level converter such as the MAX232. Ordinarily the "Flow" pin (Pin 17) is left unconnected; this pin is used only when connecting the EDE1400 to a PC. It provides a hardware handshaking signal. This signal is not necessary in ordinary asynchronous serial communication.

CONNECTION TO PRINTER

The EDE1400 requires an 11-wire connection to the printer. Eight of these are data lines, D0 through D7. The other three are the STROBE line, the BUSY line, and Ground. The following table illustrates the interface between the EDE1400 and the parallel printer's Centronics port:

Signal Name	EDE1400 Pin #	D-25 Cable Pin #	Connector on Printer
D0	Pin 6	Pin 2	Pin 2
D1	Pin 7	Pin 3	Pin 3
D2	Pin 8	Pin 4	Pin 4
D3	Pin 9	Pin 5	Pin 5
D4	Pin 10	Pin 6	Pin 6
D5	Pin 11	Pin 7	Pin 7
D6	Pin 12	Pin 8	Pin 8
D7	Pin 13	Pin 9	Pin 9
STROBE	Pin 1	Pin 1	Pin 1
BUSY	Pin 18	Pin 11	Pin 11
GND	Pin 5	Pins 18-25	Pins 19-30,33

Table One: EDE1400 Connection to Printer

Only one Ground (GND) pin needs to be connected from the EDE1400 to the printer. All other pins from the printer that are not shown in this table may be left unconnected.

USE OF THE EDE1400 WITH A BASIC STAMP™

The schematic on the following page illustrates the connection of a BASIC Stamp™ I to a printer using the EDE1400:

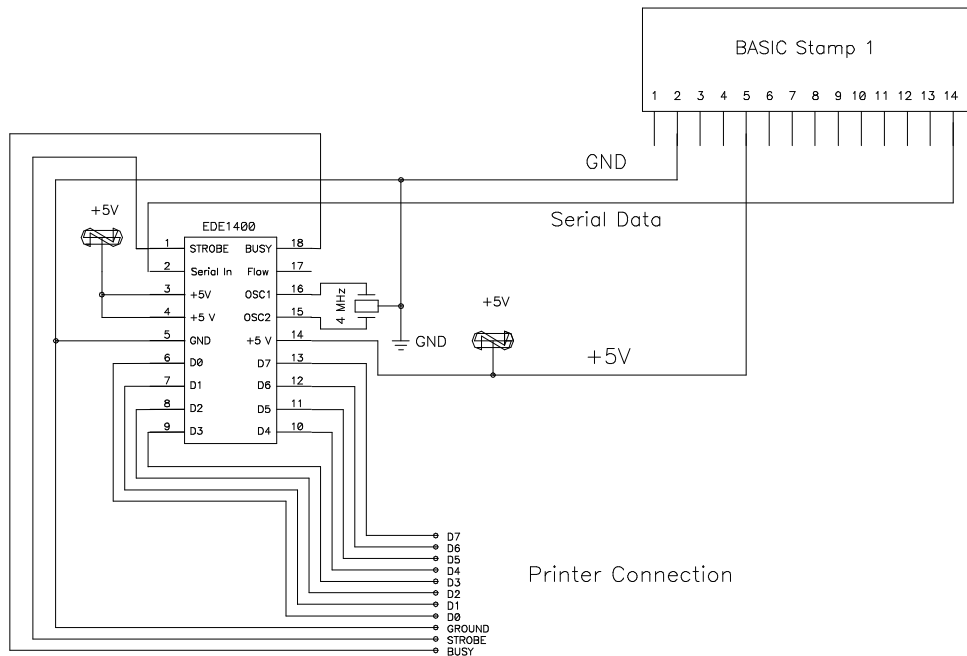

Figure One: Connection to BASIC Stamp[®]

The following program, written for the BASIC Stamp[™] I, prints the text "This text is from the Stamp I" on the printer, then advances one line and prints the numbers one through nine.

```

serout 7,T2400,("This text is from the Stamp I")
serout 7,T2400,(10) : REM Carriage Return
serout 7,T2400,(13) : REM Line Feed

for b7 = 48 to 57 : REM ASCII 0 through 9
serout 7,T2400,(b7)
next b7
serout 7,T2400,(10) : REM Carriage Return

```

If everything is connected properly, you should see the following text on the printer's paper:

**This text is from the Stamp I
0123456789**

Note: If garbled characters appear on the printer, connect a 4.7K Ohm resistor from the serial line to Vcc (+5V). Also, the wires from the EDE1400 to the printer should not exceed 15 feet; however if shielded cable is used, this length may be extended.

USE OF THE EDE1400 WITH A PC

The EDE1400 can also be used with a PC, causing data sent out the PC serial port to be printed on a parallel printer. This is convenient for extending the distance from printer to PC, testing the EDE1400-printer interface in design projects, etc. The EDE1400 should work with most types of printers, but will, of course, not provide the full range of functions gained when connecting the printer to a PC using the traditional parallel port interface (e.g. paper out, etc.)

Serial data from a PC is a true RS-232 voltage levels (-15VDC to +15VDC) and must, therefore, be changed to TTL-level signals. This can be accomplished by the use of a MAX232 voltage level converter or similar device, as illustrated in Figure Two. When writing to the EDE1400 from a terminal program, custom software, or another program that does not require hardware flow control, you will need only to connect the serial data output pin from the PC to the serial data input pin on the EDE1400 (as well as connecting printer Ground) to print on the printer. However, when printing from DOS you will also need to connect the EDE1400's hardware handshaking pin to the PC. This TTL level signal must first be sent through a TTL to RS-232 voltage level converter IC before going back to the PC. Fortunately, one MAX232 IC or similar device contains the necessary drivers to do both the incoming and outgoing conversions in one chip. When using the hardware handshaking, connect the 'Flow' pin (Pin 17) of the EDE1400 to both the PC's CTS (Clear to Send) and DSR (Data Set Ready) inputs. The following table illustrates the RS-232 pins required for both a 9-pin and a 25-pin connector:

Signal Name	9-Pin D Connector	25-Pin D Connector
Ground	Pin 5	Pin 7
Serial Transmit	Pin 3	Pin 2
CTS	Pin 8	Pin 5
DSR	Pin 6	Pin 6

Table Two: RS-232 Pin Connections

Note: The CTS and DSR pins are only necessary when the host requires that hardware flow control be used. Most hosts, such as stamps, microcontrollers, and microprocessors, do not require the use of hardware flow control; in these cases the EDE1400's 'Flow' pin would be left unconnected.

The schematic in Figure Two illustrates the connection of a parallel printer to a PC via the EDE1400. To print to is through DOS, the following command must first be issued to set serial communications port properly (COM1 is used in this case):

MODE COM1 2400 N 8 1

This instructs DOS to set the parameters of COM1 to 2400 Baud, no parity, 8 data bits, and one stop bit. To print a text file on the printer from DOS, you would type:

COPY textfile.txt COM1:

Copying the entire directory to the printer would be accomplished with:

DIR > COM1:

To re-route all output going to the LPT1: port (the standard parallel printer port) to the serial port (COM1), type:

MODE LPT1: = COM1:

The following schematic illustrates the connection of a PC to a parallel printer via the EDE1400. Notice that a MAX232 Voltage level converter IC is used to provide the interface between the EDE1400 and the PC.

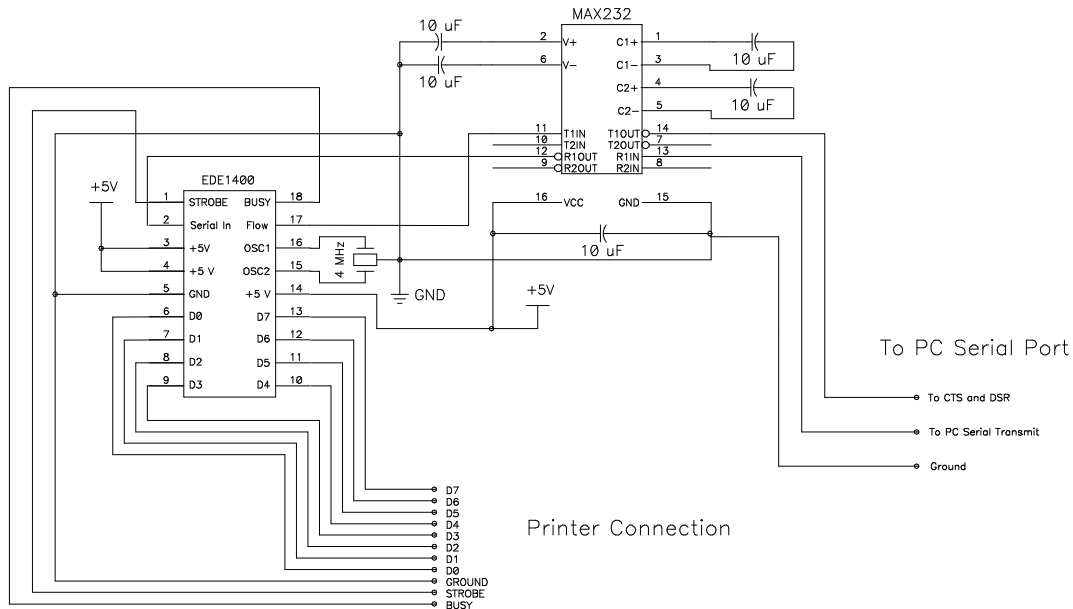

Figure Two: Connection to PC

EDE1400 SPECIAL POWER CONSIDERATIONS

If your application allows the printer to remain powered while the host system is powered down, the EDE1400 will remain powered from leakage current coming from the printer's data and control lines (which it holds high continually). This may cause garbage characters to be printed when the host is again powered up due to noise on the data line. If this is a problem in your application, it can be remedied by supplying power to the EDE1400 through a diode such as the 1N4004. In parallel with this should be a 220 Ohm, 1/8 watt resistor. The diode will allow power to flow to the EDE1400 from the host when it is powered without allowing power to return to the host system from the printer when the printer is on and the host system is powered down. The resistor is necessary to ensure that the EDE1400 will not stay powered up and operative when only the printer is powered.

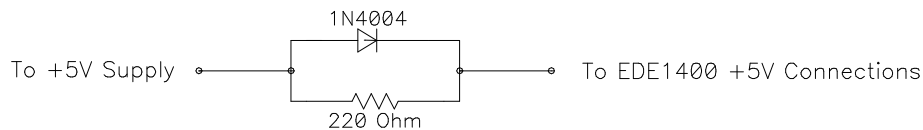

Figure Three: Alternate Power Supply Circuit

Note: You might also choose to place a 4.7K pull-up resistor on the serial data line to ensure that no data is printed on the printer due to noise on the serial line.

Although we strive to maintain a high degree of technical accuracy, this document may contain typographical errors or other inaccuracies. We reserve the right to correct any inaccuracy in future editions of this document without notice. This document and examples contained herein are provided 'As Is' without warranty of any kind expressed or implied. This document is to be used for informational purposes only and may not be duplicated for commercial purposes other than by distributors authorized by E-Lab.

ABSOLUTE MAXIMUM RATINGS

Oscillator frequency 4 MHz
Supply Voltage 6.25V
Ambient temperature under bias -55°C to +125°C
Max. current sunked by output pin 25mA
Max. current sourced by output pin 25mA

STANDARD OPERATING CONDITIONS

Supply voltage 3.0V to 5.5V
Operating temperature 0°C to +70°C

The EDE1400 IC is implemented as firmware on a PIC16C54A microcontroller, manufactured by Microchip Technology, Inc. For a more comprehensive technical summary of this device, please refer to the PIC16C54A datasheet (accessible from the E-Lab web site).

IMPORTANT NOTICE

E-LAB Digital Engineering, Inc. (E-LAB), reserves the right to change products or specifications without notice. Customers are advised to obtain the latest versions of product specifications, which should be considered when evaluating a product's appropriateness for a particular use.

THIS PRODUCT IS WARRANTED TO COMPLY WITH E-LAB'S SPECIFICATION SHEET AT THE TIME OF DELIVERY. BY USING THIS PRODUCT, CUSTOMER AGREES THAT IN NO EVENT SHALL E-LAB BE LIABLE FOR ANY DIRECT, INDIRECT, SPECIAL, INCIDENTAL OR CONSEQUENTIAL DAMAGES AS A RESULT OF THE PERFORMANCE, OR FAILURE TO PERFORM, OF THIS PRODUCT.

E-LAB MAKES NO OTHER WARRANTIES, EXPRESSED OR IMPLIED, INCLUDING ANY IMPLIED WARRANTIES OF MERCHANTABILITY OR FITNESS FOR A PARTICULAR PURPOSE.

E-LAB'S LIABILITY IS FOR A PERIOD NO GREATER THAN 90 DAYS FROM DATE OF SHIPMENT BY E-LAB AND IS LIMITED TO REPLACEMENT OF DEFECTIVE PRODUCT. This warranty covers only defects arising under normal use and not malfunctions resulting from misuse, abuse, modification, or repairs by anyone other than E-LAB.

E-LAB'S PRODUCTS ARE NOT AUTHORIZED FOR USE AS CRITICAL COMPONENTS IN LIFE SUPPORT DEVICES OR SYSTEMS WITHOUT THE EXPRESS WRITTEN APPROVAL OF THE PRESIDENT OF E-LAB. Life support devices or systems are those which are intended to support or sustain life and whose failure to perform can be reasonably expected to result in a significant injury or death to the user. Critical components are those whose failure to perform can be reasonably expected to cause failure of a life support device or system or affect its safety or effectiveness.

COPYRIGHT NOTICE

This product may not be duplicated. E-LAB Digital Engineering, Inc. holds all copyrights on firmware, with all rights reserved. Unauthorized duplication of this device may be subject to penalty under state and/ or federal law.

EDE700 and the E-LAB logo are trademarks of E-LAB Digital Engineering, Inc. All other trademarks and registered trademarks are property of their respective owners.

CONTACTING US

We are continually updating our product line. Please contact us for our latest product information.

E-LAB Digital Engineering, Inc.
1600 N. 291 Hwy. Ste. 330
P.O. Box 520436
Independence, MO 64052-0436

Telephone: (816) 257-9954
FAX: (816) 257-9945

Internet:
www.elabinc.com

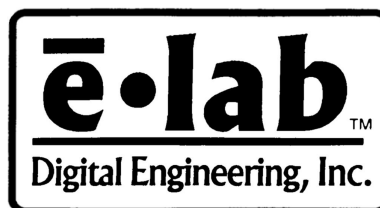

E-Mail: support@elabinc.com