

THIS DRAWING IS UNPUBLISHED. RELEASED FOR PUBLICATION  
 © COPYRIGHT BY TYCO ELECTRONICS CORPORATION. ALL INTERNATIONAL RIGHTS RESERVED.

LOC	DIST	REVISIONS					
G	14	P	LTR	DESCRIPTION	DATE	DWN	APVD
		C1		REV PER ECR 10-004402	02MAR10	JR	TM

<b>AMP</b> WIRE RANGE	Listed	LR7189 Certified
16-14 AWG SOLID OR STRANDED	16-14 AWG SOLID OR STRANDED	16-14 AWG SOLID OR STRANDED

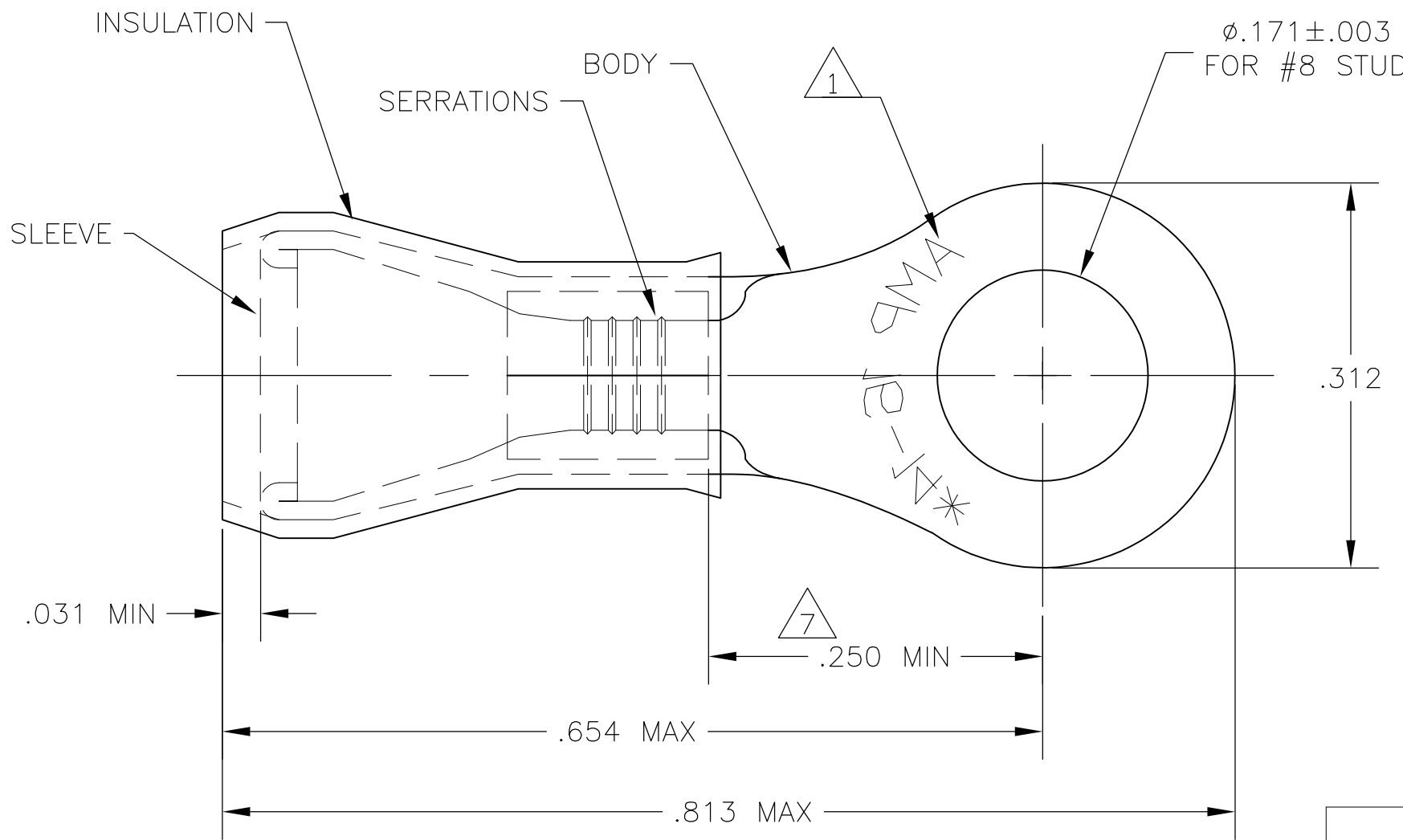

- 1 STAMP AMP 16-14\*, APPROX AS SHOWN.
- 2 TONGUE THICKNESS IS .031±.002
- 3 FOR .115-.170 WIRE INSULATION DIA
- 4 MAX RECOMMENDED OPERATING TEMP IS 105°C.
- 5 300 VOLT MAX RATING.
- 6 WIRE CROSS SECTIONAL AREA RANGE 1.04-2.62mm [2,050-5,180 CIR MILS]
- 7 APPLIES FROM EDGE OF METAL WIRE BBL TO CENTER OF STUD HOLE.

100	LOOSE PIECE, BOX	BODY & SLEEVE: COPPER PER ASTM B152 TIN PL. PER ASTM B-545 INSULATION: NYLON, TYPE I, PER ASTM D4066 COLOR: BLUE	8-53941-1
5000	ON TAPE, REEL		53941-2
1000	LOOSE PIECE		53941-1
QTY	PACKAGING	MATERIAL / FINISH	PART NO

THIS DRAWING IS A CONTROLLED DOCUMENT.		DWN jr_ruth 02MAR10	Tyco Electronics Corporation Harrisburg, PA 17105-3608	
DIMENSIONS: INCHES		CHK T MICHELUTTI 02MAR10	NAME	
TOLERANCES UNLESS OTHERWISE SPECIFIED:		APVD T MICHELUTTI 02MAR10	PRODUCT SPEC	
0 PLC ± -		UL486A-UL486B		
1 PLC ± -		APPLICATION SPEC		
2 PLC ± -		114-2157		
3 PLC ± .008		SIZE	CAGE CODE	DRAWING NO
4 PLC ± -		A300779		C-53941
ANGLES ± 1°		WEIGHT	RESTRICTED TO	
MATERIAL SEE TABLE		FINISH SEE TABLE		
		CUSTOMER DRAWING		SCALE 8:1
		SHEET 1 OF 1		REV C1