

POWER MANAGEMENT

Features

- Input supply voltage range — 3.0V to 5.5V
- Charge pump modes — 1x, 1.5x and 2x
- Flash LED — 1000mA max in flash mode, 275mA max continuous for spotlight
- Charge pump frequency — 250kHz
- I²C compatible interface — up to 400kHz
- External flash control pin to sync with camera
- One second flash time out with disable feature
- Automatic sleep mode (flash off) — I_Q = 100μA
- Low shutdown current — 0.1μA (typical)
- Ultra-thin package — 3mm x 3mm x 0.6mm
- Fully WEEE and RoHS compliant

Applications

- Cellular phone flash
- PDA flash

Description

The SC628A is a high efficiency charge pump LED driver using Semtech's proprietary charge pump technology. Performance is optimized for use in single-cell Li-ion battery applications. The load and supply conditions determine whether the charge pump operates in 1x, 1.5x, or 2x mode.

The charge pump provides continuous spotlight mode current or pulsed flash mode current to an LED using a dedicated current sink. In flash mode, a flash-timeout feature turns off the flash if active for longer than 1 second. In spotlight mode, the timeout feature is disabled to allow continuous operation of the LED.

The SC628A uses an I²C compatible serial interface to set the flash mode or the spotlight mode current. The flash/spotlight output is triggered via either the I²C interface or a dedicated flash enable pin (FLEN).

In sleep mode, the device reduces quiescent current to 100μA while continuing to monitor the serial interface. Total current reduces to 0.1μA in shutdown.

www.DataSheet4U.com

Typical Application Circuit

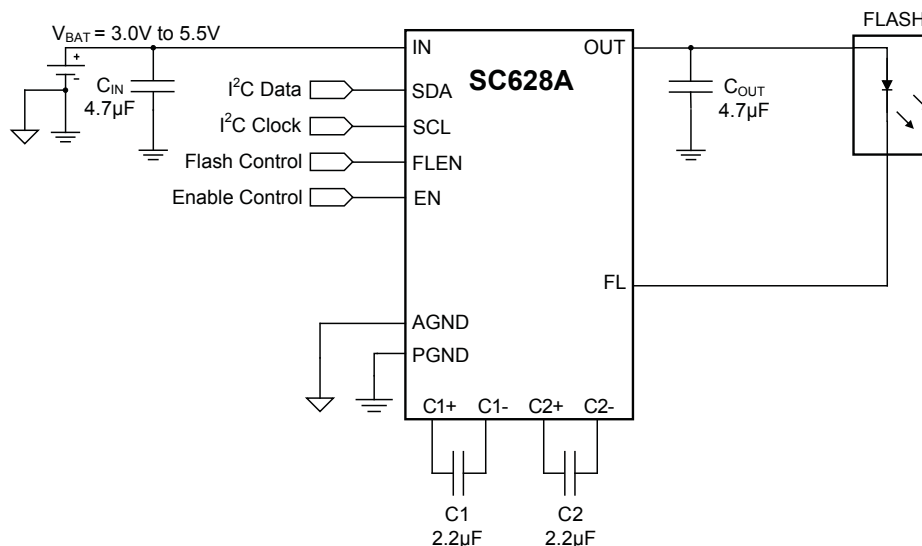

Pin Configuration

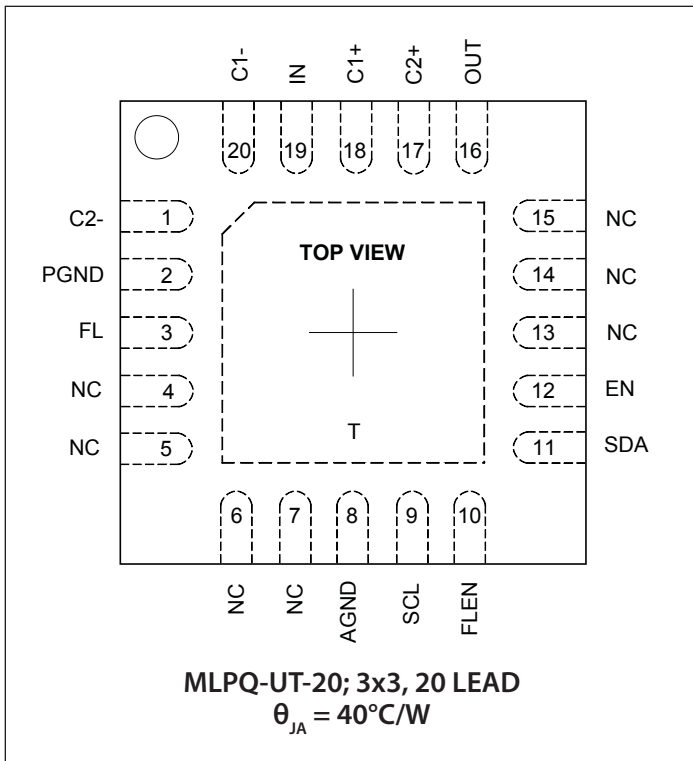

Ordering Information

Device	Package
SC628AULTRT ⁽¹⁾⁽²⁾	MLPQ-UT-20 3x3
SC628AEVB	Evaluation Board

Notes:

- (1) Available in tape and reel only. A reel contains 3,000 devices.
- (2) Lead-free package only. Device is WEEE and RoHS compliant.

Marking Information

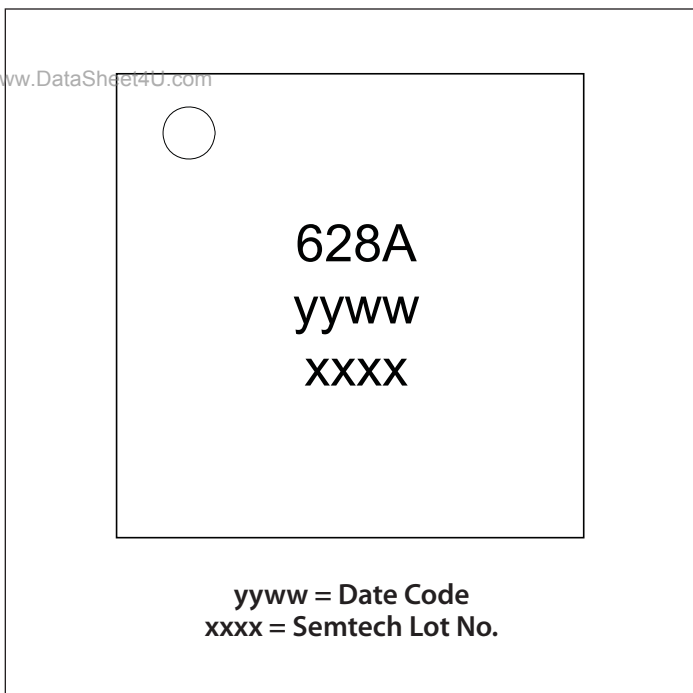

Absolute Maximum Ratings

IN (V)	-0.3 to +6.0
OUT (V).....	-0.3 to +6.0
C1+, C2+ (V).....	-0.3 to (V _{OUT} + 0.3)
Pin Voltage - All Other Pins (V).....	-0.3 to (V _{IN} + 0.3)
OUT Short Circuit Duration	Continuous
ESD Protection Level ⁽¹⁾ (kV)	2

Recommended Operating Conditions

Ambient Temperature Range (°C).....	-40 ≤ T _A ≤ +85
IN (V)	3.0 ≤ V _{IN} ≤ 5.5
OUT (V)	2.5 ≤ V _{OUT} ≤ 5.25

Thermal Information

Thermal Resistance, Junction to Ambient ⁽²⁾ (°C/W)	40
Maximum Junction Temperature (°C)	+150
Storage Temperature Range (°C).....	-65 to +150
Peak IR Reflow Temperature (10s to 30s) (°C)	+260

Exceeding the above specifications may result in permanent damage to the device or device malfunction. Operation outside of the parameters specified in the Electrical Characteristics section is not recommended.

NOTES:

(1) Tested according to JEDEC standard JESD22-A114-B.

(2) Calculated from package in still air, mounted to 3" x 4.5", 4 layer FR4 PCB with thermal vias under the exposed pad per JESD51 standards.

Electrical Characteristics

Unless otherwise noted, T_A = +25°C for Typ, -40°C to +85°C for Min and Max, T_{J(MAX)} = 125°C, V_{IN} = 3.0V to 4.2V, C_{IN} = C_{OUT} = 4.7µF (ESR = 0.03Ω), C₁ = C₂ = 2.2µF (ESR = 0.03Ω), size code 0603 (1608 metric) for all capacitors

Parameter	Symbol	Conditions	Min	Typ	Max	Units
Supply Specifications						
Shutdown Current	I _{Q(OFF)}	Shutdown, V _{IN} = 4.2V		0.1	2	µA
Total Quiescent Current	I _Q	Sleep, EN = V _{IN}		100	160	µA
		Charge pump in 1x mode		3.8	4.65	mA
		Charge pump in 1.5x mode		4.6	5.85	
		Charge pump in 2x mode		4.6	5.85	
Fault Protection						
Output Short Circuit Current Limit	I _{OUT(SC)}	OUT pin shorted to GND		450		mA
Over-Temperature	T _{OTP}			160		°C
Flash Mode Safety Timer ⁽¹⁾	t _{FL(MAX)}	Flash sink active	0.75	1.00	1.25	s
Charge Pump Over-Voltage Protection	V _{OVF}	OUT pin open circuit, V _{OUT} = V _{OVF} rising threshold	5.3	5.7	6.0	V

Electrical Characteristics (continued)

Parameter	Symbol	Conditions	Min	Typ	Max	Units
Fault Protection (continued)						
Undervoltage Lockout	V_{UVLO}	Increasing V_{IN}		2.7		V
	$V_{UVLO-HYS}$	Hysteresis		800		mV
Charge Pump Electrical Specifications						
Maximum Total Output Current	$I_{OUT(MAX)}$	$V_{IN} > 3.5V, V_{OUT(MAX)} = 4.0V$	1000			mA
Flash Current Settling Time	t_{FL_SET}	maximum time for current to settle		1		ms
Flash Current Setting	I_{FL}	Nominal setting for FL	25		1000	mA
Flash Current Accuracy	I_{FL_ACC}	$V_{IN} = 3.7V, I_{FL} = 450mA, T_A = 25^\circ C$	-13	± 5	13	%
1x Mode to 1.5x Mode Falling Transition Voltage	$V_{TRANS1x}$	$I_{OUT} = 150mA, V_{OUT} = 3.3V$		3.37		V
1.5x Mode to 2x Mode Falling Transition Voltage	$V_{TRANS1.5x}$	$I_{OUT} = 150mA, V_{OUT} = 4.5V^{(2)}$		3.3		V
Current Sink Off-State Leakage Current	I_{BLn}	$V_{IN} = V_{FL} = 4.2V$		0.1	1	μA
Pump Frequency	f_{PUMP}	$V_{IN} = 3.2V$		250		kHz
Digital I/O Electrical Specifications (FLEN, EN)						
Input High Threshold	V_{IH}	$V_{IN} = 5.5V$	1.4			V
Input Low Threshold	V_{IL}	$V_{IN} = 3.0V$			0.4	V
Input High Current	I_{IH}	$V_{IN} = 5.5V$	-1		+1	μA
Input Low Current	I_{IL}	$V_{IN} = 5.5V$	-1		+1	μA
I²C Interface						
Interface complies with slave mode I ² C interface as described by Philips I ² C specification version 2.1 dated January, 2000.						
Digital Input Voltage	V_{B-IL}				0.4	V
	V_{B-IH}		1.4			V
SDA Output Low Level		$I_{DIN} (SDA) \leq 3mA$			0.4	V
Digital Input Current	I_{B-IN}		-0.2		0.2	μA
Hysteresis of Schmitt Trigger Inputs	V_{HYS}			0.1		V
Maximum Glitch Pulse Rejection	t_{SP}			50		ns
I/O Pin Capacitance	C_{IN}			10		pF

Electrical Characteristics (continued)

Parameter	Symbol	Conditions	Min	Typ	Max	Units
I²C Timing						
Clock Frequency	f_{SCL}			400	440	kHz
SCL Low Period ⁽³⁾	t_{LOW}		1.3			μ s
SCL High Period ⁽³⁾	t_{HIGH}		0.6			μ s
Data Hold Time ⁽³⁾	t_{HD_DAT}		0			μ s
Data Setup Time ⁽³⁾	t_{SU_DAT}		250			ns
Setup Time for Repeated START Condition ⁽³⁾	t_{SU_STA}		0.6			μ s
Hold Time for Repeated START Condition ⁽³⁾	t_{HD_STA}		0.6			μ s
Setup Time for STOP Condition ⁽³⁾	t_{SU_STO}		0.6			μ s
Bus-Free Time Between STOP and START ⁽³⁾	t_{BUF}		1.3			μ s
Interface Start-up Time ⁽³⁾	t_{EN}	Bus Start-up Time After EN Pin is Pulled High			1	ms

Notes:

- (1) Once tripped, flash output will remain disabled until FLEN pin is cycled or reset via serial interface.
- (2) Test voltage is $V_{OUT} = 4.5V$ — a relatively extreme LED voltage — to force a transition during test. Typically $V_{OUT} = 3.3V$ for the white LED at 100mA.
- (3) Guaranteed by design

Typical Characteristics

Spotlight Current — 25mA

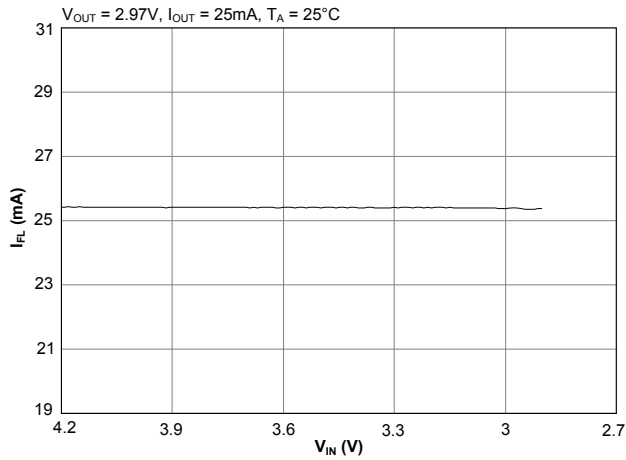

Flash Current — 400mA

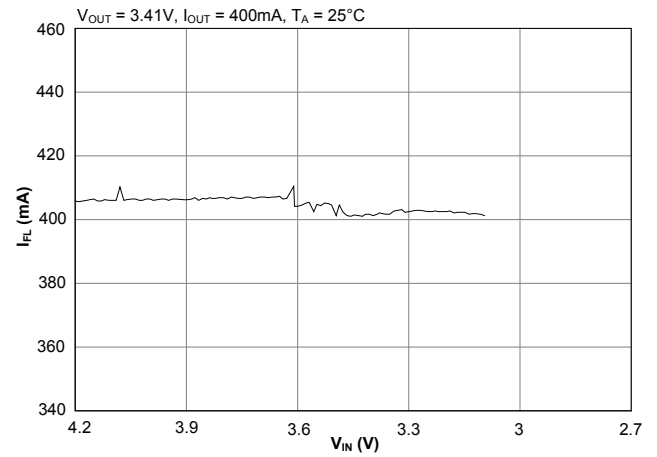

Spotlight Current — 100mA

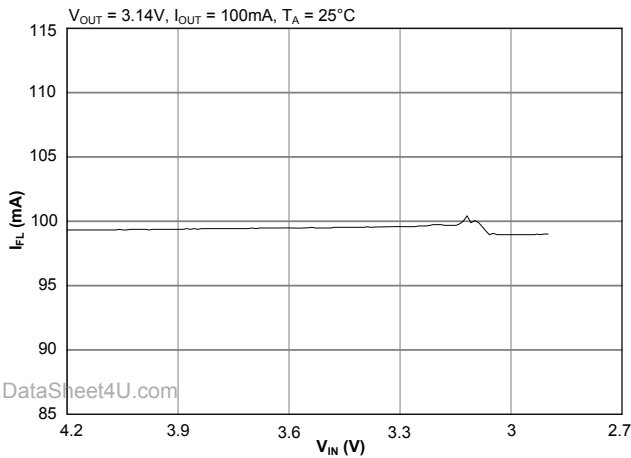

Flash Current — 875mA

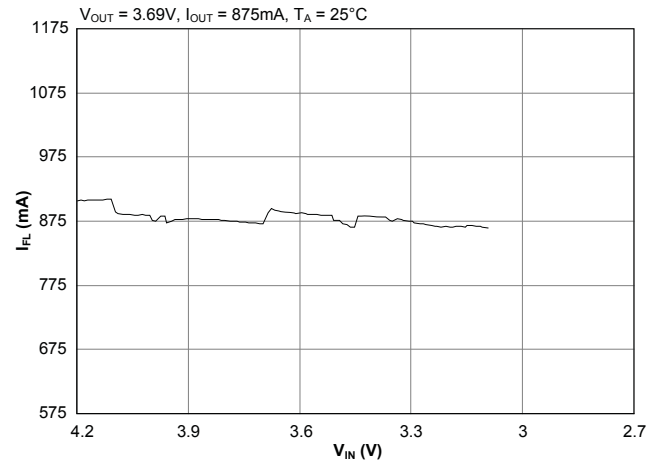

Spotlight Current — 275mA

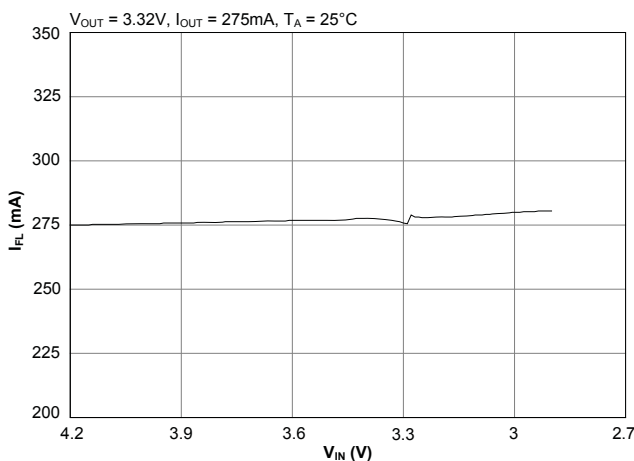

Flash Current — 1000mA

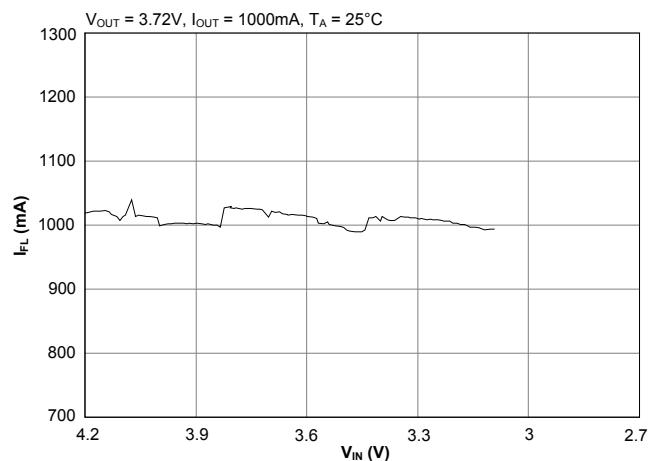

Typical Characteristics (continued)

Spotlight Efficiency — 25mA

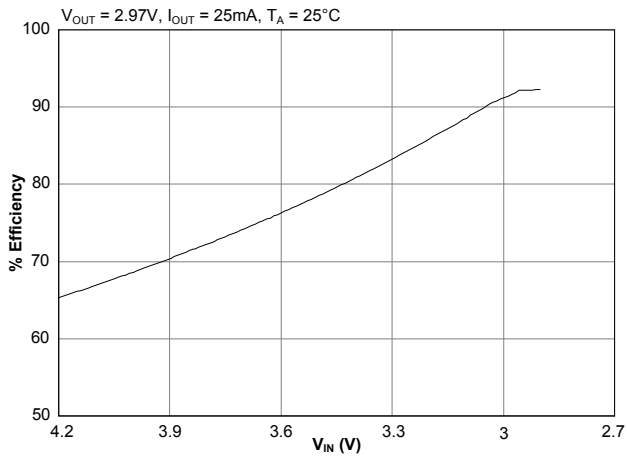

Spotlight Efficiency — 275mA

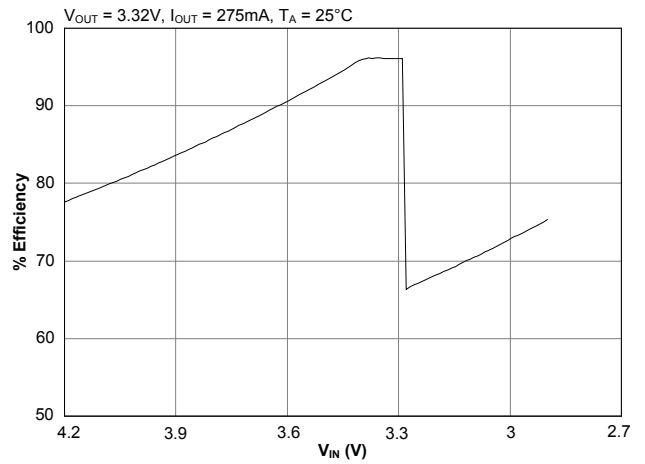

Spotlight Efficiency — 100mA

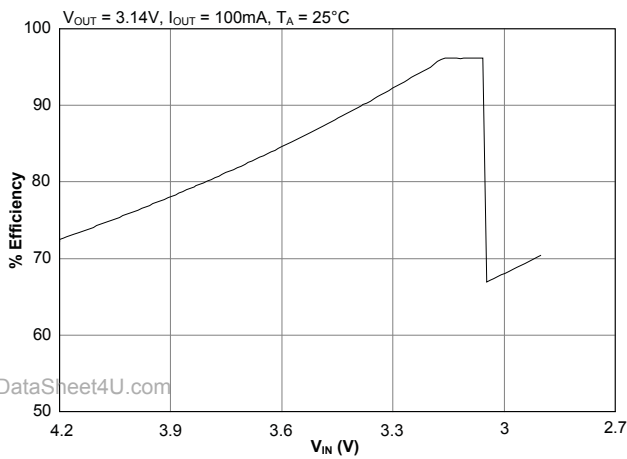

Flash Efficiency — 400mA

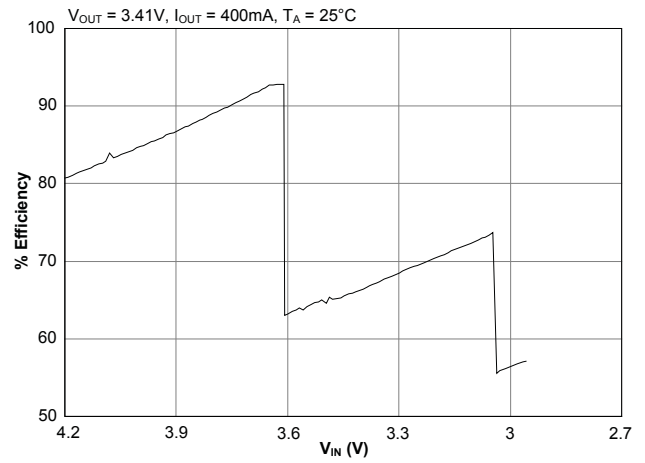

Typical Characteristics (continued)

Spotlight Mode Ripple — 1x Mode

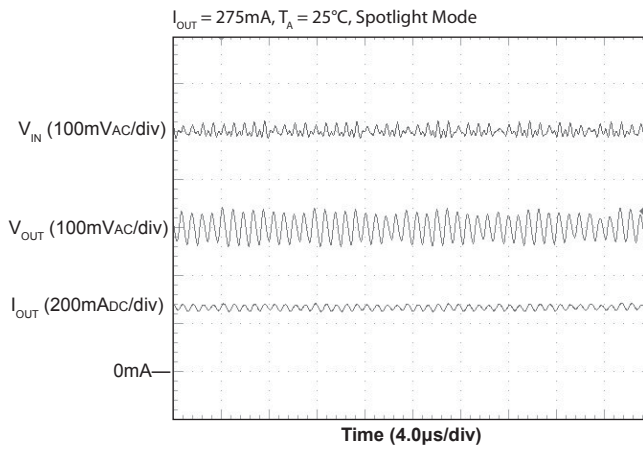

Spotlight Mode Ripple — 1.5x Mode

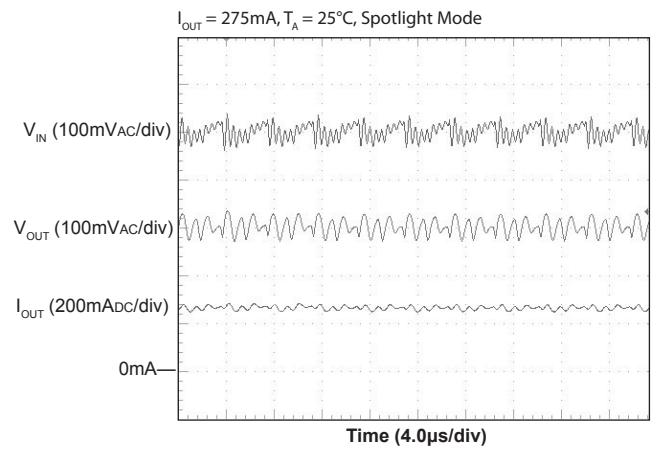

Flash Mode Ripple — 1x Mode

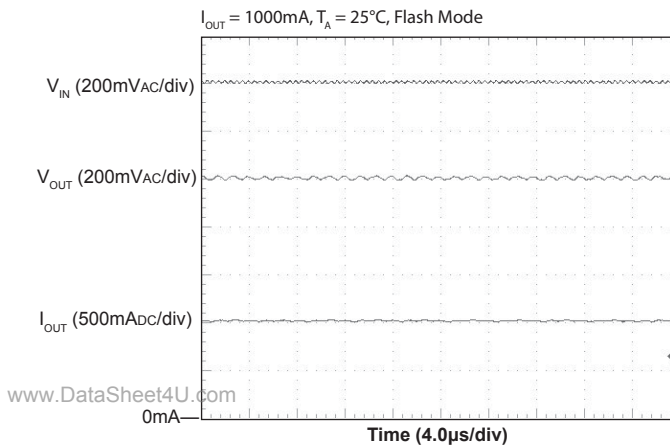

Flash Mode Ripple — 1.5x Mode

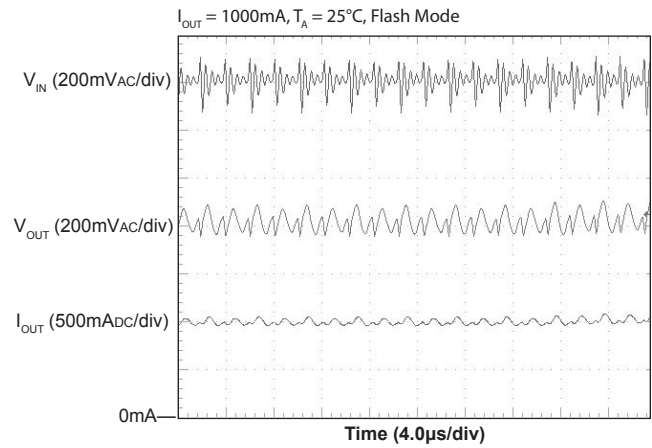

Flash Mode Ripple — 2x Mode

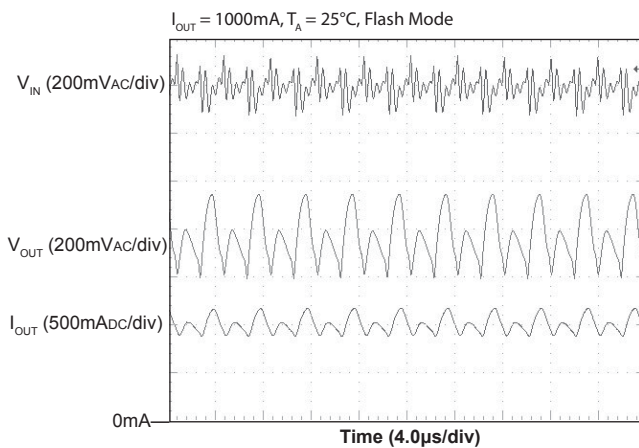

Flash Current Pulse

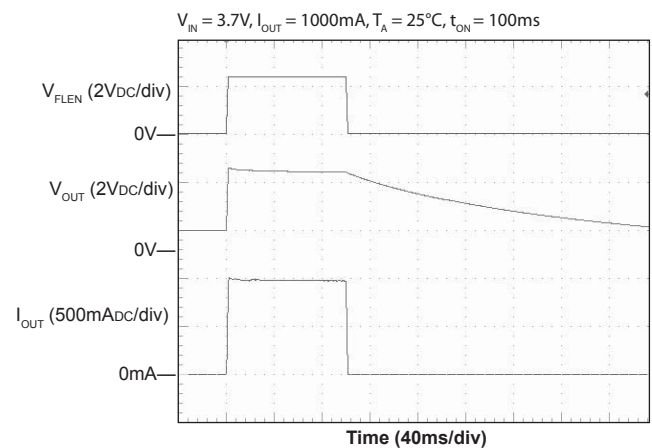

Typical Characteristics (continued)

Flash Mode Safety Timer

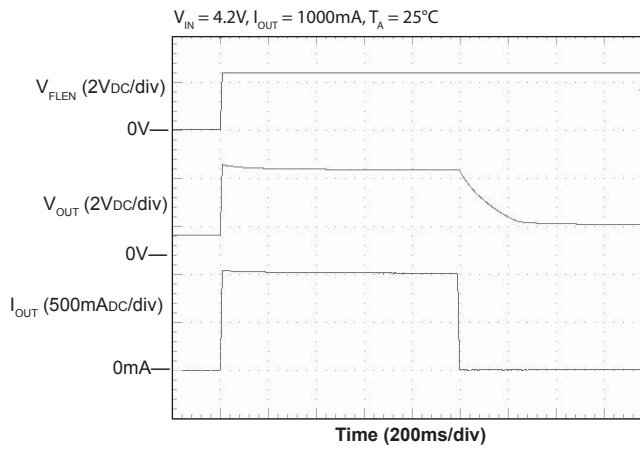

Output Open Circuit Protection

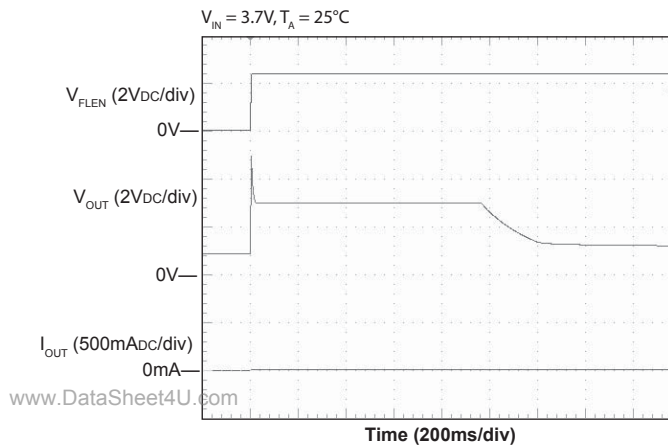

Output Short Circuit Current Limit

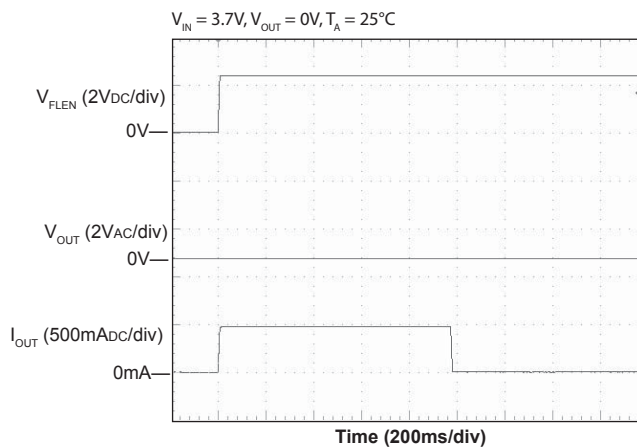

Pin Descriptions

Pin #	Pin Name	Pin Function
1	C2-	Negative connection to bucket capacitor 2 — requires a 2.2 μ F capacitor connected to C2+
2	PGND	Ground pin for high current charge pump and Flash LED driver
3	FL	Current sink output for flash LED(s)
4	NC	Unused pin — do not terminate
5	NC	Unused pin — do not terminate
6	NC	Unused pin — do not terminate
7	NC	Unused pin — do not terminate
8	AGND	Analog ground pin — connect to ground and separate from PGND current
9	SCL	I ² C clock input pin
10	FLEN	Control pin for flash LED(s) — high = ON, low = OFF
11	SDA	I ² C bi-directional data pin — used for read and write operations for all internal registers (refer to Register Map and I ² C Interface sections)
12	EN	Chip enable — active high — low state resets all registers (see register map table)
13	NC	Unused pin — do not terminate
14	NC	Unused pin — do not terminate
15	NC	Unused pin — do not terminate
16	OUT	Charge pump output — all LED anode pins should be connected to this pin — requires a 4.7 μ F capacitor to PGND
17	C2+	Positive connection to bucket capacitor 2 — requires a 2.2 μ F capacitor connected to C2-
18	C1+	Positive connection to bucket capacitor 1 — requires a 2.2 μ F capacitor connected to C1-
19	IN	Battery voltage input — connect with a 4.7 μ F capacitor to PGND
20	C1-	Negative connection to bucket capacitor 1 — requires a 2.2 μ F capacitor connected to C1+
T	THERMAL PAD	Thermal pad for heatsinking purposes — connect to ground plane using multiple vias — not connected internally

Block Diagram

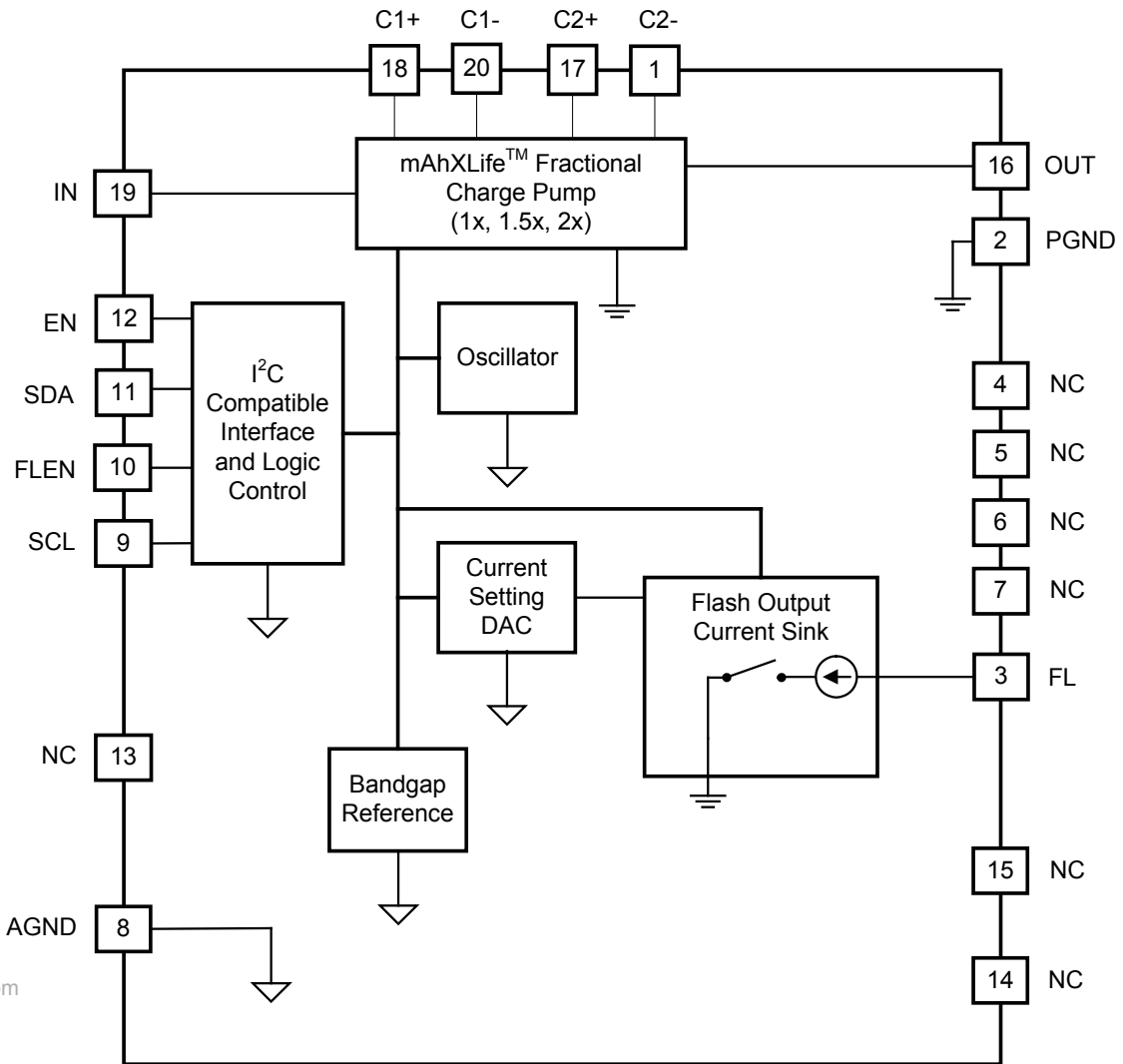

www.DataSheet4U.com

Applications Information

General Description

This design is optimized for handheld applications supplied from a single Li-Ion cell and includes the following key features:

- A high efficiency fractional charge pump that supplies power to the flash LED
- An LED flash output that provides up to 1000mA of momentary current or up to 275mA of continuous spotlight current
- An I²C compatible interface that provides control of all device functions

High Current Fractional Charge Pump

The flash output is supported by a high efficiency, high current fractional charge pump output at the OUT pin. The charge pump multiplies the input voltage by 1, 1.5, or 2 times. The charge pump switches at a fixed frequency of 250kHz in 1.5x and 2x modes and is disabled in 1x mode to save power and improve efficiency.

The mode selection circuit automatically selects the 1x, 1.5x or 2x mode based on circuit conditions. Circuit conditions such as low input voltage, high output current, or high LED voltage place a higher demand on the charge pump output. A higher numerical mode may be needed momentarily to maintain regulation at the OUT pin during intervals of high demand, such as the high current of an LED flash or the droop at the IN pin during a supply voltage transient. The charge pump responds to these momentary high demands, setting the charge pump to the optimum mode (1x, 1.5x or 2x), as needed to deliver the output voltage and load current while optimizing efficiency. Hysteresis is provided to prevent mode toggling.

The charge pump requires two bucket capacitors for low ripple operation. One capacitor must be connected between the C1+ and C1- pins and the other must be connected between the C2+ and C2- pins as shown in the typical application circuit diagram. These capacitors should be equal in value, with a minimum capacitance of 2.2 μ F to support the charge pump current requirements.

The device also requires a 4.7 μ F capacitor on the IN pin and a 4.7 μ F capacitor on the OUT pin to minimize noise and support the output drive requirements. Capacitor case size is an important factor in the performance of the SC628A. Due to the poor DC coefficient of the 0402 size (1005 metric), 0603 size (1608 metric) capacitors are strongly recommended to achieve the rated electrical specifications and performance shown in the typical characteristics section.

Capacitors with X7R or X5R ceramic dielectric are strongly recommended for their low ESR and superior temperature and voltage characteristics. Y5V capacitors should not be used as their temperature coefficients make them unsuitable for this application.

LED Flash and Spotlight Current Sink

A single output current sink is provided to drive both flash and spotlight functions. In flash mode, this current sink provides up to 1000mA for a flash LED or array of parallel LEDs. Flash current settings are available in 21 values from 300mA to 1000mA. Flash steps increments are no larger than 75mA nominally. Some additional settings that have smaller increments of 50mA, 25mA and 12.5mA. Table 1 on page 12 contains detailed current setting information for flash mode. The FLEN pin directly triggers the FLASH function when pulled high, or it can be wired to IN to enable software control via the serial interface.

In spotlight mode, the output can be set for up to 275mA of continuous current. Settings are available in 25mA increments from 25mA to 275mA, with some additional settings that have smaller increments of 12.5mA. Table 2 on page 13 contains detailed current setting information for spotlight mode. Continuous operation above 275mA is not recommended due to high power dissipation.

Flash and Spotlight Safety Timer

A safety timer disables the flash and spotlight output current sink if the sink remains active for an extended period. The timer protects the SC628A and the LED from high power dissipation that can cause overheating. The

Applications Information (continued)

timer's default state is on, but the timer may be disabled via the serial interface to allow continuous output current in spotlight mode. The safety timer affects only the FL pin and will turn off the sink after a period of 1 second. The timer may be reset by either forcing the FLEN pin low or by resetting the Flash/Spotlight control bits via the interface.

Shutdown State

The device is disabled when the EN pin is low. All registers are reset to default condition when EN is low.

Sleep Mode

When the LED is off, sleep mode is activated. This is a reduced current mode that helps minimize overall current consumption by turning off the clock and the charge pump while continuing to monitor the serial interface for commands.

I²C Compatible Interface Functions

All device functions can be controlled via the I²C compatible interface. The interface is described in detail in the Serial Interface section of the datasheet.

Protection Features

The SC628A provides several protection features to safeguard the device from catastrophic failures. These features include:

- Output Open Circuit Protection
- Over-Temperature Protection
- Charge Pump Output Current Limit
- LED Float Detection

Output Open Circuit Protection

Over-Voltage Protection (OVP) is provided at the OUT pin to prevent the charge pump from producing an excessively high output voltage. In the event of an open circuit at OUT, the charge pump runs in open loop and the voltage rises up to the OVP limit. OVP operation is hysteretic, meaning the charge pump will momentarily turn off until V_{OUT} is sufficiently reduced. The maximum OVP threshold is 6.0V, allowing the use of a ceramic output capacitor rated at 6.3V with no fear of over-voltage damage.

Over-Temperature Protection

The Over-Temperature (OT) protection circuit helps prevent the device from overheating and experiencing a catastrophic failure. When the junction temperature exceeds 160°C, the device goes into thermal shutdown with all outputs disabled until the junction temperature is reduced. All register information is retained during thermal shutdown.

Charge Pump Output Current Limit

The device also limits the charge pump current at the OUT pin. When OUT is shorted to ground, the typical output current is 400mA. The current limiting is triggered by an output under-voltage lockout below 2V. The output returns to normal when the short is removed and OUT is above 2.5V. Above 2.5V, a minimum current limit of 1000mA applies.

LED Float Detection

Float detect is a fault detection feature of the LED current sink output. If the output is programmed to be enabled and an open circuit fault occurs on the current sink, the resulting open loop will cause the output voltage to change to the default condition $V_{OUT} = 3.0V$. The output will remain 3.0V until the loop is once again completed by an LED or the output is re-programmed to the off state.

Applications Information (continued)

PCB Layout Considerations

The layout diagram in Figure 1 illustrates a proper two-layer PCB layout for the SC628A and supporting components. Following fundamental layout rules is critical for achieving the performance specified in the Electrical Characteristics table. The following guidelines are recommended when developing a PCB layout:

- Place all bypass and decoupling capacitors — C1, C2, CIN, and COUT as close to the device as possible.
- All charge pump current passes through IN, OUT, and the bucket capacitor connection pins. Ensure that all connections to these pins make use of wide traces so that the resistive drop on each connection is minimized.
- The thermal pad should be connected to the ground plane using multiple vias to ensure proper thermal connection for optimal heat transfer.

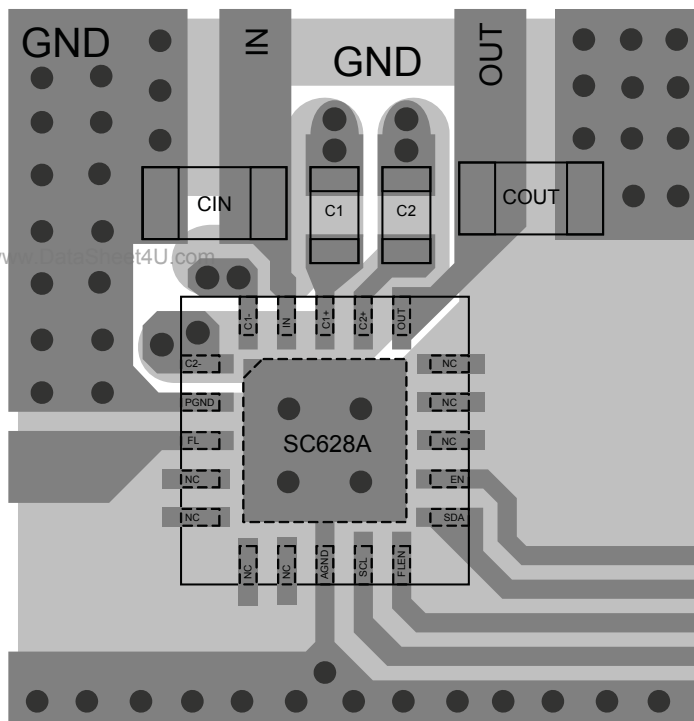

Figure 1 — Recommended PCB Layout

- Make all ground connections to a solid ground plane as shown in the example layout (Figure 3).
- If a ground layer is not feasible, the following groupings should be connected:
 - PGND — CIN, COUT
 - AGND — Ground Pad
- If no ground plane is available, PGND and AGND should be routed back to the negative battery terminal as separate signals using thick traces.

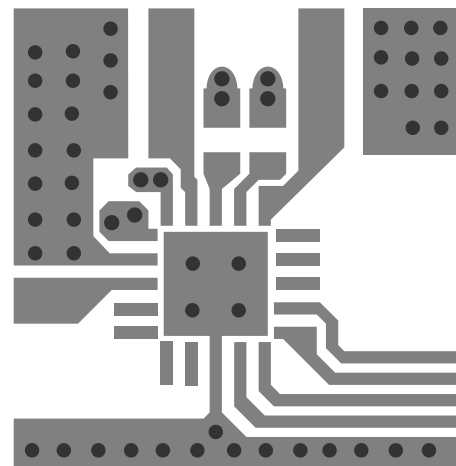

Figure 2 — Layer 1

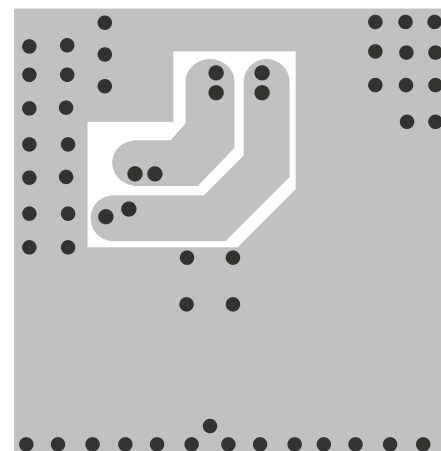

Figure 3 — Layer 2

Register Map

Address	D7	D6	D5	D4	D3	D2	D1	D0	Reset Value	Description
0x02	Flash/Spotlight Bits		0 ⁽¹⁾	FLTO	Flash/Spotlight Bits				0x10	Flash/Spotlight Control

Notes:

(1) Always write a 0 to this bit

Register and Bit Definitions

Flash/Spotlight Control Register (0x02)

This register is used to select the flash or spotlight current and to configure the flash time-out feature.

Bits D7, D6, D3, D2, D1, D0

The value of bits D7, D6, D3, D2, D1, and D0 are used to set the current for the flash and spotlight modes. Flash current values are set in accordance with Table 1 on page 12, and spotlight current values are set in accordance with Table 2 on page 13.

FLTO

This bit is used to enable the flash safety time-out feature. The default state is enabled with FLTO = 1. If this bit is set, the device will turn off the flash after a nominal period of 1s. Two ways to re-enable the flash function after a safety time-out are:

www.DataSheet4U.com

- Pull the FLEN pin low to reset the flash function
- Clear and re-write bits D7, D6 D3, D2, D1, and D0.

Register and Bit Definitions (continued)

Table 1 — Flash Current Codes⁽¹⁾

Data Bits for Register 02h								Flash Current	8 Bit Word
D7	D6	D5	D4	D3	D2	D1	D0	I _{FL} (mA)	Hex
x ⁽²⁾	x ⁽²⁾	0 ⁽³⁾	1 ⁽⁴⁾	0	0	0	0	OFF	00h
0	1	0 ⁽³⁾	1 ⁽⁴⁾	1	0	1	1	300	5Bh
0	1	0 ⁽³⁾	1 ⁽⁴⁾	1	1	0	1	325	5Dh
1	1	0 ⁽³⁾	1 ⁽⁴⁾	0	1	0	1	337.5	D5h
0	0	0 ⁽³⁾	1 ⁽⁴⁾	1	1	1	0	350	1Eh
1	0	0 ⁽³⁾	1 ⁽⁴⁾	1	0	1	0	375	9Ah
0	0	0 ⁽³⁾	1 ⁽⁴⁾	0	0	1	1	400	13h
1	1	0 ⁽³⁾	1 ⁽⁴⁾	1	0	0	1	412.5	D9h
0	0	0 ⁽³⁾	1 ⁽⁴⁾	0	1	0	1	450	15h
1	1	0 ⁽³⁾	1 ⁽⁴⁾	1	1	0	1	487.5	DDh
0	0	0 ⁽³⁾	1 ⁽⁴⁾	0	1	1	1	500	17h
1	1	0 ⁽³⁾	1 ⁽⁴⁾	1	1	1	1	525	DFh
0	0	0 ⁽³⁾	1 ⁽⁴⁾	1	0	0	1	550	19h
0	0	0 ⁽³⁾	1 ⁽⁴⁾	1	0	1	1	600	1Bh
0	0	0 ⁽³⁾	1 ⁽⁴⁾	1	1	0	1	650	1Dh
1	0	0 ⁽³⁾	1 ⁽⁴⁾	0	1	0	1	675	95h
0	0	0 ⁽³⁾	1 ⁽⁴⁾	1	1	1	1	700	1Fh
1	0	0 ⁽³⁾	1 ⁽⁴⁾	0	1	1	1	750	97h
1	0	0 ⁽³⁾	1 ⁽⁴⁾	1	0	0	1	825	99h
1	0	0 ⁽³⁾	1 ⁽⁴⁾	1	0	1	1	875	9Bh
1	0	0 ⁽³⁾	1 ⁽⁴⁾	1	1	0	1	950	9Dh
1	0	0 ⁽³⁾	1 ⁽⁴⁾	1	1	1	1	1000	9Fh

Notes:

- (1) Use only the data values shown in Table 1 for flash function.
- (2) Either 1 or 0.
- (3) Always write a 0 to this bit.
- (4) Write a 1 to set the FLTO bit for flash mode.

Register and Bit Definitions (continued)

Table 2 — Spotlight Current Codes⁽¹⁾

Data Bits for Register 02h								Spotlight Current	8 Bit Word
D7	D6	D5	D4	D3	D2	D1	D0	I _{FL} (mA)	Hex
x ⁽²⁾	x ⁽²⁾	0 ⁽³⁾	0 ⁽⁴⁾	0	0	0	0	OFF	00h
0	1	0 ⁽³⁾	0 ⁽⁴⁾	0	0	1	0	25	42h
1	1	0 ⁽³⁾	0 ⁽⁴⁾	0	0	1	0	37.5	C2h
0	0	0 ⁽³⁾	0 ⁽⁴⁾	0	0	1	0	50	02h
0	1	0 ⁽³⁾	0 ⁽⁴⁾	0	1	1	0	75	46h
0	0	0 ⁽³⁾	0 ⁽⁴⁾	0	1	0	0	100	04h
1	1	0 ⁽³⁾	0 ⁽⁴⁾	0	1	1	0	112.5	C6h
0	1	0 ⁽³⁾	0 ⁽⁴⁾	1	0	1	0	125	4Ah
0	0	0 ⁽³⁾	0 ⁽⁴⁾	0	1	1	0	150	06h
0	1	0 ⁽³⁾	0 ⁽⁴⁾	1	1	1	0	175	4Eh
1	1	0 ⁽³⁾	0 ⁽⁴⁾	1	0	1	0	187.5	CAh
0	0	0 ⁽³⁾	0 ⁽⁴⁾	1	0	0	0	200	08h
0	1	0 ⁽³⁾	0 ⁽⁴⁾	0	1	0	1	225	45h
0	1	0 ⁽³⁾	0 ⁽⁴⁾	0	1	1	1	250	47h
1	1	0 ⁽³⁾	0 ⁽⁴⁾	1	1	1	0	262.5	CEh
0	1	0 ⁽³⁾	0 ⁽⁴⁾	1	0	0	1	275	49h

Notes:

(1) Use only the data values shown in Table 2 for spotlight function.

(2) Either 1 or 0.

www.DataSheet4U.com

(3) Always write a 0 to this bit.

(4) Write a 0 to reset the FLTO bit for spotlight mode.

Serial Interface

The I²C General Specification

The SC628A is a read-write slave-mode I²C device and complies with the Philips I²C standard Version 2.1, dated January 2000. The SC628A has four user-accessible internal 8-bit registers. The I²C interface has been designed for program flexibility, supporting direct format for write operation. Read operations are supported on both combined format and stop separated format. While there is no auto increment/decrement capability in the SC628A I²C logic, a tight software loop can be designed to randomly access the next register independent of which register you begin accessing. The start and stop commands frame the data-packet and the repeat start condition is allowed if necessary.

SC628A Limitations to the I²C Specifications

The SC628A only recognizes seven bit addressing. This means that ten bit addressing and CBUS communication are not compatible. The device can operate in either standard mode (100kbit/s) or fast mode (400kbit/s).

Slave Address Assignment

The seven bit slave address is 0110 111x. The eighth bit is the data direction bit. 0x6E is used for a write operation, and 0x6F is used for a read operation.

Supported Formats

The supported formats are described in the following subsections.

Direct Format — Write

The simplest format for an I²C write is direct format. After the start condition [S], the slave address is sent, followed

by an eighth bit indicating a write. The SC628A I²C then acknowledges that it is being addressed, and the master responds with an 8 bit data byte consisting of the register address. The slave acknowledges and the master sends the appropriate 8 bit data byte. Once again the slave acknowledges and the master terminates the transfer with the stop condition [P].

Combined Format — Read

After the start condition [S], the slave address is sent, followed by an eighth bit indicating a write. The SC628A I²C then acknowledges that it is being addressed, and the master responds with an 8 bit data byte consisting of the register address. The slave acknowledges and the master sends the repeated start condition [Sr]. Once again, the slave address is sent, followed by an eighth bit indicating a read. The slave responds with an acknowledge and the previously addressed 8 bit data byte; the master then sends a non-acknowledge (NACK). Finally, the master terminates the transfer with the stop condition [P].

Stop Separated Reads

Stop-separated reads can also be used. This format allows a master to set up the register address pointer for a read and return to that slave at a later time to read the data. In this format the slave address followed by a write command are sent after a start [S] condition. The SC628A then acknowledges it is being addressed, and the master responds with the 8-bit register address. The master sends a stop or restart condition and may then address another slave. After performing other tasks, the master can send a start or restart condition to the SC628A with a read command. The device acknowledges this request and returns the data from the register location that had previously been set up.

Serial Interface (continued)

I²C Direct Format Write



S – Start Condition
W – Write = '0'
A – Acknowledge (sent by slave)
P – Stop condition

Slave Address – 7-bit
Register address – 8-bit
Data – 8-bit

I²C Stop Separated Format Read

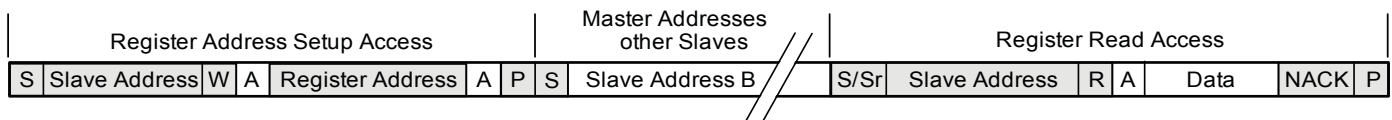

S – Start Condition
W – Write = '0'
R – Read = '1'
A – Acknowledge (sent by slave)
NAK – Non-Acknowledge (sent by master)
Sr – Repeated Start condition
P – Stop condition

Slave Address – 7-bit
Register address – 8-bit
Data – 8-bit

I²C Combined Format Read



S – Start Condition
W – Write = '0'
R – Read = '1'
A – Acknowledge (sent by slave)
NAK – Non-Acknowledge (sent by master)
Sr – Repeated Start condition
P – Stop condition

Slave Address – 7-bit
Register address – 8-bit
Data – 8-bit

Outline Drawing — MLPQ-UT-20 3x3

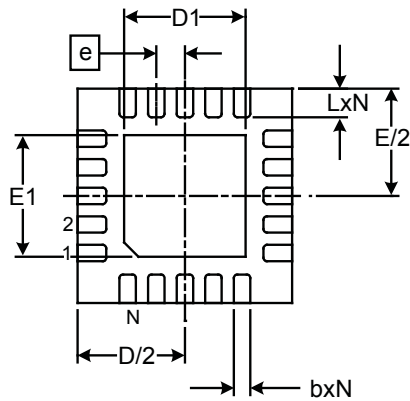
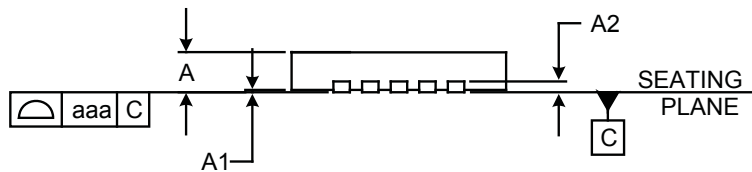
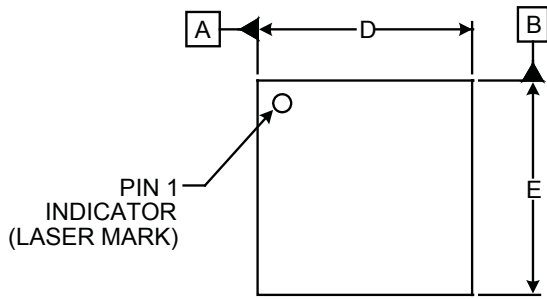

DIM	INCHES			MILLIMETERS		
	MIN	NOM	MAX	MIN	NOM	MAX
A	.020	-	.024	0.50	-	0.60
A1	.000	-	.002	0.00	-	0.05
A2	(.006)			(0.1524)		
b	.006	.008	.010	0.15	0.20	0.25
D	.114	.118	.122	2.90	3.00	3.10
D1	.061	.067	.071	1.55	1.70	1.80
E	.114	.118	.122	2.90	3.00	3.10
E1	.061	.067	.071	1.55	1.70	1.80
e	.016 BSC			0.40 BSC		
L	.012	.016	.020	0.30	0.40	0.50
N	20			20		
aaa	.003			0.08		
bbb	.004			0.10		

www.DataSheet4U.com

NOTES:

1. CONTROLLING DIMENSIONS ARE IN MILLIMETERS (ANGLES IN DEGREES).
2. COPLANARITY APPLIES TO THE EXPOSED PAD AS WELL AS THE TERMINALS.
3. DAP is 1.90 x 190mm.

Land Pattern — MLPQ-UT-20 3x3

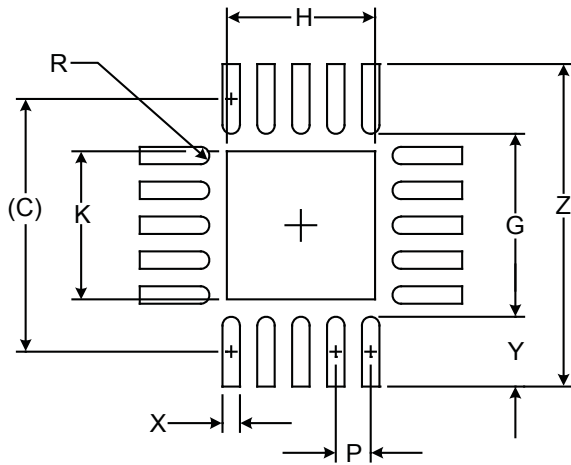

DIMENSIONS		
DIM	INCHES	MILLIMETERS
C	(.114)	(2.90)
G	.083	2.10
H	.067	1.70
K	.067	1.70
P	.016	0.40
R	.004	0.10
X	.008	0.20
Y	.031	0.80
Z	.146	3.70

NOTES:

1. CONTROLLING DIMENSIONS ARE IN MILLIMETERS (ANGLES IN DEGREES).
2. THIS LAND PATTERN IS FOR REFERENCE PURPOSES ONLY. CONSULT YOUR MANUFACTURING GROUP TO ENSURE YOUR COMPANY'S MANUFACTURING GUIDELINES ARE MET.
3. THERMAL VIAS IN THE LAND PATTERN OF THE EXPOSED PAD SHALL BE CONNECTED TO A SYSTEM GROUND PLANE. FAILURE TO DO SO MAY COMPROMISE THE THERMAL AND/OR FUNCTIONAL PERFORMANCE OF THE DEVICE.

www.DataSheet4U.com

Contact Information

Semtech Corporation
Power Management Products Division
200 Flynn Road, Camarillo, CA 93012
Phone: (805) 498-2111 Fax: (805) 498-3804

www.semtech.com