

PCF50606/605

Single-chip Power Management Unit +

Each Philips PMU+ is a complete, highly integrated power management unit designed for PDAs, smartphones, webpads and other handheld products. The PMU+ incorporates on-chip battery management, a touchscreen interface and more.



Semiconductors

The latest additions to a growing family of highly integrated mixed-signal companion chips, the Philips PCF50606 and PCF50605 power management unit 'plus' (PMU+) ICs dramatically reduce board space and significantly lower overall cost in handheld devices such as PDAs, smartphones, and webpads. Each PMU+ also supports real-time, software-controlled power management, a feature that can reduce overall system power consumption by up to 70%. The full-featured PCF50606 PMU+ combines an efficient set of programmable power supplies, a flexible battery management system, a 10-bit analog-to-digital converter (ADC) and a touchscreen interface. The PCF50605 PMU+ offers the same power management features without an on-chip touchscreen interface, ADC, or battery management.

Features

- > Complete system power management on a single chip
- > Integrates functions to reduce board space by up to 50%
- > Fully compatible with Intel® XScale™ and other processors
- > Software-programmable power supplies for design flexibility: up to three integrated DC/DC converters and five LDO voltage regulators with parallel, low-current LDOs
- > Software-controlled real-time power management can dramatically reduce power consumption and extend battery life
- > Battery management system with battery voltage monitor, backup battery support, charger control with multiple charge modes, and 10-bit ADC
- > 10-bit touchscreen interface
- > Optional 32-kHz Xtal oscillator output for generating real-time clock
- > Up to six programmable GPOs
- > Space-saving, 56-pin leadless HVQFN package (8 x 8 x 1 mm)
- > Complete evaluation kit with PC control software

Each PMU+ is fully compatible with the Intel XScale architecture and other processors designed for mobile use. It operates from a three-cell NiCd/NiMH or a one-cell Li-Ion/Li-Polymer battery pack and is available in a space-saving, 56-pin leadless HVQFN package measuring only 8 x 8 x 1 mm.

Real-time Power Management

As battery-powered systems take on more functionality and incorporate more advanced processors and DSPs, power management becomes increasingly complex. To address this issue, each PMU+ supports real-time power management, a feature that allows various settings to be adjusted dynamically. Full software control is provided through an I²C interface, so power management can be programmed for different options and can adapt to different operating conditions.

Real-time Power Management

The PMU+ supports real-time power management, a feature that extends battery life by letting the system adapt to different operating conditions. By fine-tuning the supply voltages, designers can create highly optimized, power-efficient systems. PMU+s support up to eight different software-controllable supply-voltage domains, such as memory, backlight, or I/O supply, etc.

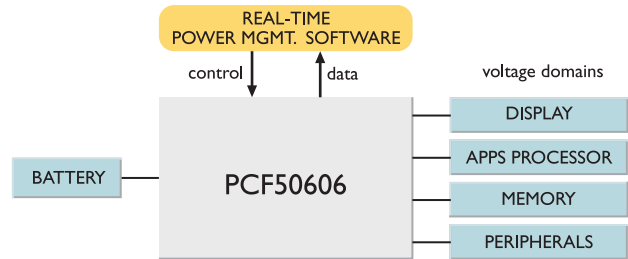

For designs using next-generation processors, each PMU+ supports dynamic voltage management enabling the CPU's power consumption to be scaled to reflect changes in performance requirements. A PMU+ can also scale voltages in other parts of the system. For example, the power supplies can be switched off when a voltage domain is not operational. Or, when data needs to be retained, the supply voltage to memory can be temporarily lowered to reduce power consumption. The DC/DC converters automatically switch to a more power-efficient mode at low-load currents and offer an ECO mode for added power savings. The low-dropout (LDO) voltage regulators also support

an ECO mode, reducing their internal power consumption in low-current conditions such as sleep mode.

Mask-Programmable Options

All the default start-up settings, including the power supply start-up values, are mask-programmable on the PMU+s. Through hardwired control, designers can select programmed voltages and define changes in operation for groups of power supplies. This saves considerable design time and frees up resources for creating more advanced functionality.

A PCF50606 PMU+ provides power management for an entire system including the display, the applications processor, the memory and the peripherals.

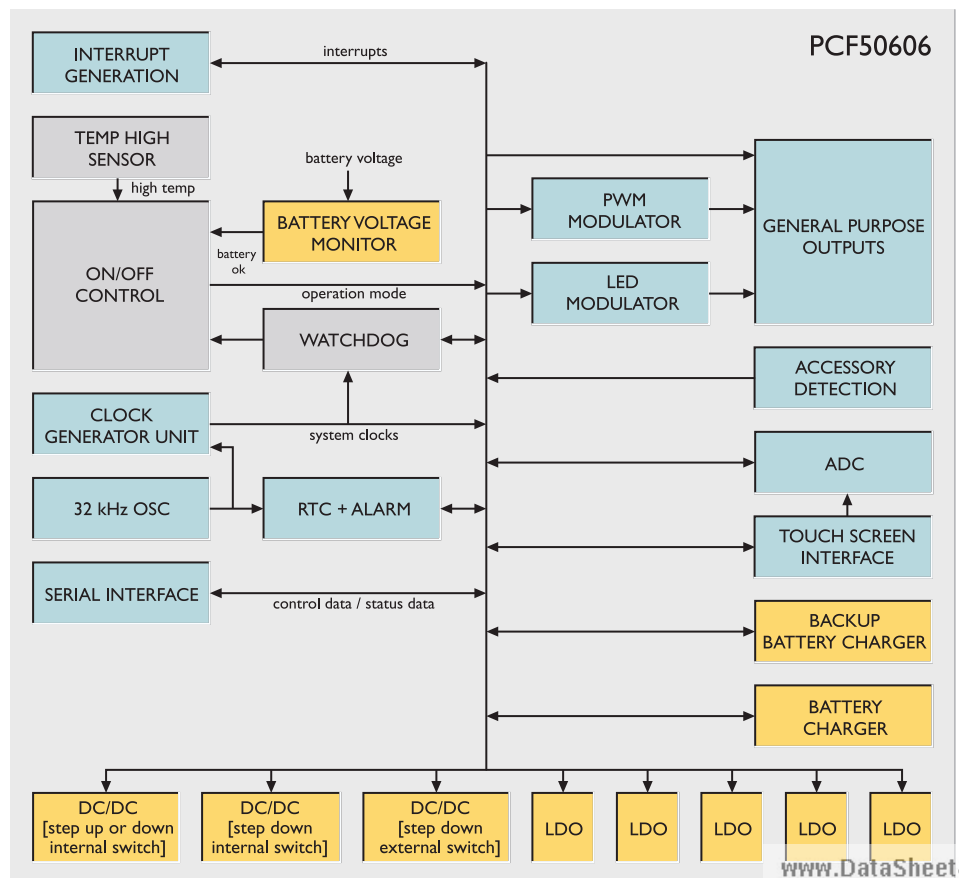

PMU+ Functional Overview

Communication and Control

A PMU+ controls the power ramp-up and power ramp-down for a PDA, smartphone, webpad, or other handheld device. It also controls several system operating modes, including active, save, standby, no power, and sleep. On-chip modules support the power control and battery management functions.

- > A serial 400-kHz I²C link delivers control data and status to and from the host controller.
- > An optional 32-kHz oscillator output generates the real-time clock and provides time reference and alarm functions with wake-up control.
- > An internal, current-controlled oscillator generates the internal system clock.
- > An interrupt controller generates the interrupt request for the host controller. All interrupt sources can be masked.
- > An eight-second watchdog timer can be reset via the I²C interface and can be used to shut down the PMU+.
- > A temperature-high sensor provides thermal protection for the entire IC.

Programmable Power Supplies

Each PMU+ offers two types of programmable power supplies: DC/DC converters and LDO voltage regulators. All start-up values are mask-programmable, and all can be configured using software control.

DC/DC Converters

A PMU+ integrates up to three high-efficiency DC/DC converters with programmable output voltage, mask-programmable

reset voltage, and programmable operation modes (on, off, and ECO mode for additional power savings). All DC/DC converters offer a feature that automatically switches the converter to a more power-efficient operating mode at low-load currents.

The first DC/DC converter (DCD), a fully integrated, 500-mA step-down converter, is typically used to generate the host controller core supply voltage. In configurations that use sub-2V regulators, it can also be used as a pre-regulator for the LDOs to improve system power efficiency. The second DC/DC converter (DCUD) is a fully integrated up/down converter. In step-up mode, with currents up to 500 mA, it is typically used as the audio amplifier and display supply. In step-down mode, with currents up to 500 mA, DCUD can be used to generate low supply voltage. Or, to improve power efficiency, it can be used as a pre-regulation stage for the linear regulators.

Available on PCF50606/605 'B' versions, the third DC/DC converter (DCDE) is a step-down converter with built-in drivers for external power FETs. It is typically used to generate high-current (two or more amps) supply voltage for memory systems, wireless communications, or accessories.

Programmable LDO Regulators

Each PMU+ integrates five LDO voltage regulators with programmable output (0.90 to 3.30 V in steps of 100 mV) and mask-programmable reset voltages. All LDOs are optimized for low noise, high power supply rejection and excellent load regulation. The ECO mode, which uses a parallel, low-current LDO, limits output to five mA and significantly reduces the internal power consumption. The LDOs require only 470 nF from external capacitors, keeping overall board space to a minimum.

Programmable DC/DC Converters

	NOMINAL CURRENT	MIN. VOLTAGE	MAX. VOLTAGE	VOLTAGE STEPS	PFM/PWM	CONFIGURATION
DCD	500 mA	0.90 V	3.30 V	25 mV / 300 mV	yes	down
DCUD	500 mA (up or down)	0.90 V	5.50 V	300 mV / 100 mV	yes	up or down
DCDE	determined by external components	0.90 V	3.30 V	300 mV	yes	down

V_{SS} = REFGND = *GND = 0 V; T_{amb} = -40 to +85 °C; unless otherwise specified.

Philips Semiconductors Leadership in Power Management

Backed by world-renown research, Philips power management ICs are used by some of the most widely recognized names in portable electronics and cellular handsets. Mobile phones using Philips PMUs have achieved standby time of 550 hours, establishing the industry standard.

Philips Semiconductors offers best-in-class DC/DC converter technology with seamless PFM/PWM mode switching. And after being first with the world's smallest DC/DC converter (the TEA1207UK measuring only 2 x 2 mm), Philips recently introduced the ground-breaking TEA1211, a DC/DC converter offering both up and down conversion, plus I²C-programmable output voltage.

Battery Management

The PCF50606 PMU+ operates from a three-cell NiCd/NiMH or a one-cell Li-Ion/Li-Polymer battery pack. Enhanced six-kV ESD protection is provided on all pins connected to the main battery pack. Integrated functions, including a battery voltage supervisor, a charger control, and backup battery support, ensure efficient battery use and extend battery life.

Battery Chargers and On-board Voltage Monitor

The PCF50606 PMU+ provides two battery chargers: a main charger and a backup charger. The main charger offers extensive safety features including a detector for over-voltage, battery-voltage and temperature monitors, and a dedicated watchdog/charge-timer circuit. Through a built-in switch, the battery charger also supports use of a controller charger plug. For systems using Li-Ion/Li-Polymer batteries, the main battery charger uses a constant-current/constant-voltage method. The fast-charge current can be adjusted externally, maximum battery voltage is programmable, and charging can take place with or without interaction from the host controller. To increase the efficiency of each charge, a programmable, constant-voltage mode is available. The on-chip battery voltage monitor uses programmable threshold levels to detect when main battery voltage is too low.

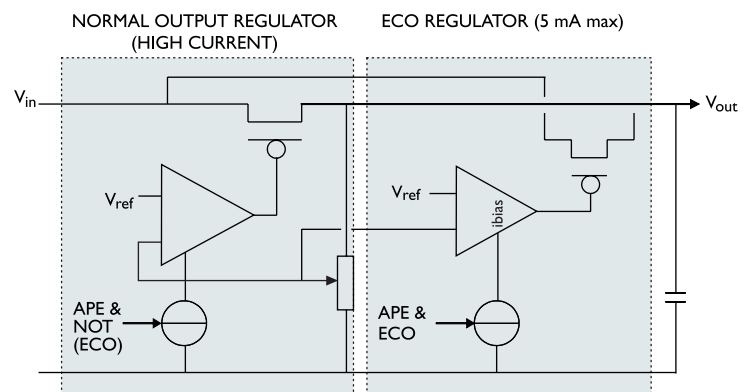

ECO mode circuitry in the LDOs saves energy in low-power states.

10-bit ADC

The PCF50606 integrates a 10-bit ADC with analog input multiplexer. The ADC supports direct connection of some voltages without the use of external voltage dividers or loss of resolution. An accessory detection comparator connected to the ADC can issue an interrupt when an accessory is connected. The ADC can be synchronized in one of two ways: by sampling the host controller operation mode, or, if connected to cellular functionality, by sampling the phone transmit frames.

Touchscreen Interface

The PCF50606 touchscreen interface provides read-out of a resistive, four-wire touchscreen, generating an interrupt when the touchscreen is pressed. It biases the touchscreen during X and Y coordinate measurements and multiplexes the touchscreen terminal to the ADC input. To minimize software overhead, only one I²C command is required to measure the combined X and Y position or to take P1 and P2 plate resistor measurements.

General-Purpose Outputs (GPOs)

PMU+s offer up to six GPOs, programmable through the serial interface as continuous low or high. Four are CMOS outputs supplied from the IOVDD supply. The others are open-drain NMOST outputs capable of handling the full battery voltage range and high-sink currents. A pulse-width modulator (PWM) generates an output voltage with programmable duty cycle and frequency. An integrated LED modulator can generate eight different blinking patterns with four different repetition periods, even when the system is in sleep mode. The GPO outputs can be controlled by the LED or the PWMs.

Evaluation Kit and PC Software

The PCF50606/605 evaluation kit includes an evaluation board and software to manipulate a PMU+ from a standard PC. For example, designers can use the software to modify programmable settings, such as the output voltage on a DC/DC converter.

Control software, included in the evaluation kit, makes it simple for hardware designers to modify programmable settings in any PCF5060x PMU+.

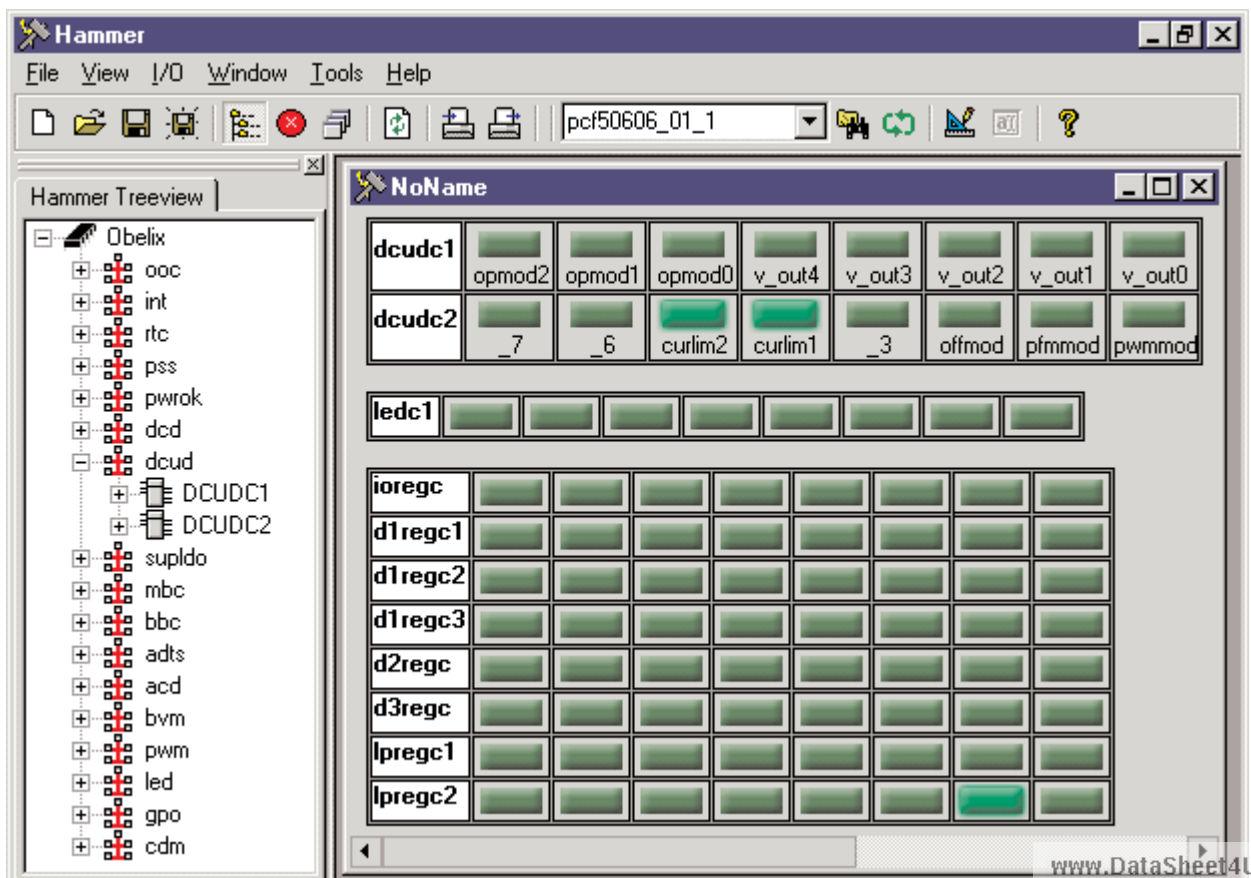

PCF56060

Single-chip Power Management Unit +

Semiconductors

	606HN/0xA/N1	606HN/0xB/N1	605HN/0xA/N1	605HN/0xB/N1
<i>PCF5060x PMU+ Product Variations</i>				
DC/DC converters	2	3	2	3
LDO voltage regulators	5	5	5	5
GPOs	6	3	6	3
Touchscreen interface	*	*		
10-bit ADC	*	*		
Battery charger	*	*		
32.786-kHz clock out	*		*	
400-kHz I²C serial interface	*	*	*	*

Philips Semiconductors

Philips Semiconductors is a worldwide company with over 100 sales offices in more than 50 countries. For a complete up-to-date list of our sales offices please e-mail sales.addresses@www.semiconductors.philips.com. A complete list will be sent to you automatically. You can also visit our website <http://www.semiconductors.philips.com/sales/> or contact any of the following sales offices by phone or mail:

North America

Philips Semiconductors C.R.M Center
2800 Wells Branch Parkway
Mailstop P-411
Austin, Texas 78728
United States

Tel: +1 800 234 7381

Fax: +1 800 943 0087

E-mail: P411webinq.smi@harte-hanks.com

Asia Pacific

Philips Semiconductors Asia Pacific
Market Response Management Center
P.O. Box 68115
Kowloon East Post Office
Hong Kong

Fax: +852 2756 8271

Europe, Africa, Middle East and South America

Philips Semiconductors International
Fulfillment and Sales Support Center
P. O. Box 366
2700 AJ Zoetermeer
The Netherlands

Fax: +31 79 3685126

Japan

Philips Semiconductors
Philips Building 13-37
Kohnan 2-chome
Minato-ku,
Tokyo 108-8507

Tel: +81 3 3740 5130

Fax: +81 3 3740 5057

© Philips Electronics N.V. 2002

All rights reserved. Reproduction in whole or in part is prohibited without the prior written consent of the copyright owner. The information presented in this document does not form part of any quotation or contract, is believed to be accurate and reliable and may be changed without notice. No liability will be accepted by the publisher for any consequence of its use. Publication thereof does not convey or imply any license under patent - or other industrial or intellectual property rights.

