

GENERAL DESCRIPTION

The BL1062 and BL1062A are Bipolar integrated circuits that perform all speech and line interface functions required in fully electronic telephone sets. They perform electronic switching between dialing and speech. The ICs operate at line voltage down to 1.6V DC to facilitate the use of more telephone sets connected in parallel.

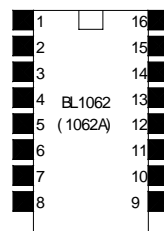

采用 16 脚双列直插式塑封

FEATURES

Low DC line voltage; operates down to 1.6V

Voltage regulator with adjustable static resistance

Provides a supply for external circuits

Symmetrical high-impedance input(64k)for dynamic, magnetic or piezoelectric microphones

Asymmetrical high-impedance input(32)for electret microphones

DTMF signal input with confidence tone

Mute input for pulse or DTMF dialing

— BL1062: active HIGH (MUTE)

— BL1062A: active LOW ($\overline{\text{MUTE}}$)

Receiving amplifier for dynamic, magnetic or piezoelectric earpieces

Large gain setting ranges by external resistance on receiving and transition amplifiers

Line loss compensation (line current dependent) for microphone and earpiece amplifiers

Compatible with TEA1062/1062A

Process with 3um Bipolar technics

PARAMETERS

LIMITING VALUES

Positive continuous line voltage V_{In}	12V
Repetitive line voltage during switch-on or line interruption $V_{In}(r)$	13.2V
Repetive peak line voltage for a 1 ms pulse per 5 s $V_{In}(rm)$	28V
Line current I_{line}	140mA
Input voltage on all other pins V_i	-0.7 ~ $V_{CC}+0.7V$
Total power dissipation P_{tot}	666mW
Storage temperature T_{stg}	-40 ~ +125
Operating ambient temperature T_{amb}	-25 ~ +75

CHARACTERISTICS

SYMOL	CONDITIONS	MIN.	TYP.	MAX.	UNIT
V _{ln}	MIC input open-circuit				
	I _{line} =1mA	--	1.6	--	V
	I _{line} =4mA	--	1.9	--	V
	I _{line} =15mA	--	4.0	4.25	V
V _{ln}	I _{line} =100mA	--	5.7	6.5	V
	I _{line} =15mA				
	RVA(LN to REG)=68k	--	3.5	--	V
	RVA(REG to SLPE)=39k	--	4.5	--	V
I _{cc}	V _{cc} =2.8V		0.9	1.35	
V _{cc}	I _{line} =15mA				
	MUTE=Hign(1062)Low(1062A)	2.2	2.7	--	V
	I _p =1.2mA	--	3.4	--	V
	I _p =0mA				
Z _i (microphone inputs)	Between MIC- and MIC+	--	64	--	k
CMRR		--	82	--	dB
G _v (microphone Inputs)	I _{line} =15mA R7=68k	50.5	52.0	53.5	dB
G _{vf}	F=300 and 3400 Hz	--	± 0.2	--	dB
G _{vT}	Without R6; I _{line} =15mA; T _{amb} =-25 and +75	--	± 0.2	--	dB
Z _i (DTMF input)		--	20.7	--	k
G _v (DTMF input)	I _{line} =15mA	24.0	25.5	27.0	dB
	R7=68k				
	F=300 and 3400Hz	--	± 0.2	--	dB
	Without R6; I _{line} =15mA; T _{amb} = -25 and +75	--	± 0.2	--	dB
V _{ln} (rms)	THD=10%				
	I _{line} =4mA	--	0.8	--	V
	I _{line} =15mA	--	2.3	--	V
Z _i (receiving amplifier)		--	21	--	k
G _v (receiving amplifier)	I _{line} =15mA	29.5	31	32.5	dB
	R7=68k				
	f=300 and 3400Hz	--	± 0.2	--	dB
	without R6;I _{line} =15mA; T _{amb} = -25 and +75	--	± 0.2	--	dB
Z _o (receibing amplifier)		--	4	--	
V _o (rms)	THD=2%;sine ware drive;				
	R4=100k ;I _{line} =15mA;				
	I _p =0mA;				
	RL=150	0.22	0.33	--	V

	RL=450	0.3	0.48	--	V
Vo (rms)	THD=10%;R4=100k ; RL=150 ;Iline=4mA	--	15	--	mV
Gv (from microphone to LN)	MUTE=High(1062) MUTE=Low(1062A)	--	70	--	dB
Gv (from DTMF to QR)	R4=100k ;RL=300 ; MUTE=High(1062) MUTE=Low(1062A)	--	-17	--	dB
Gv(automatic Gaincontrol AGC)	R6=100k ;Iline=70mA	--	-5.8	--	dB
Iline H		--	23	--	mA
Iline L		--	61	--	mA

PINNING

SYMBOL	PIN	DESCRIPTION
LN	1	Positive line terminal
GAS1	2	Gain adjustment; transmitting amplifier
GAS2	3	Gain adjustment; transmitting amplifier
QR	4	Non-inverting output; receiving amplifier
GAR	5	Gain adjustment; receiving amplifier
MIC -	6	Inverting microphone input
MIC +	7	Non-inverting microphone input
STAB	8	Current stabilizer
VEE	9	Negative line terminal
IR	10	Receiving amplifier input
DTMF	11	Dual-tone multi-frequency input
MUTE	12	Mute input
Vcc	13	Positive supply decoupling
REG	14	Voltage regulator decoupling
AGC	15	Automatic gain control input
SLPE	16	Slope(DC resistance) adjustment

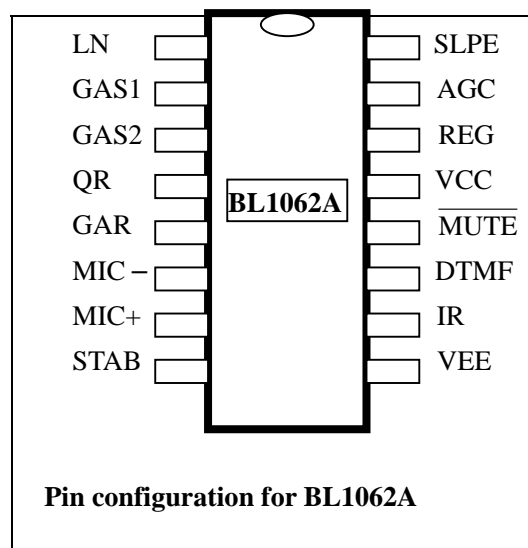
BLOCK DIAGRAM

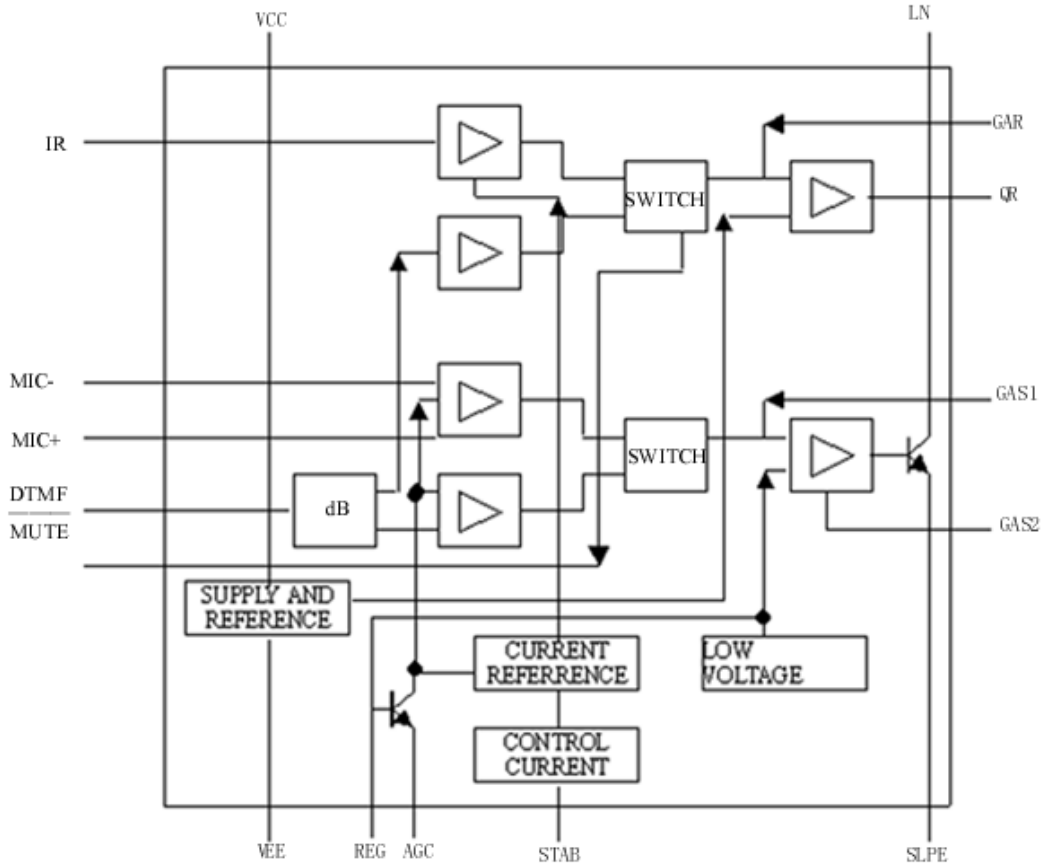

Typical application of BL1062A, with piezoelectric earpiece and DTMF dialing

