

TOLERANCE UNLESS SPECIFIED =

.XXX= +/- .005

.XX= +/- .015

FRACTIONS= +/- .032

36-560.DC2

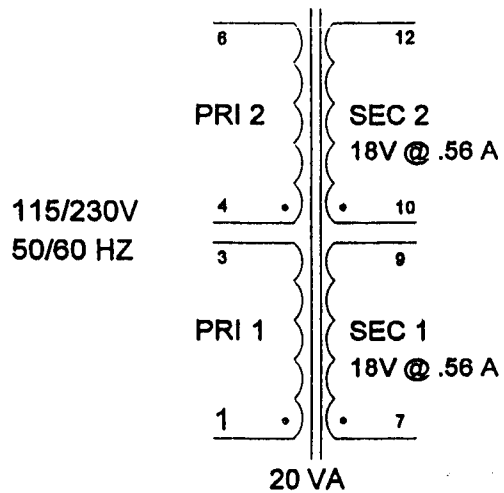
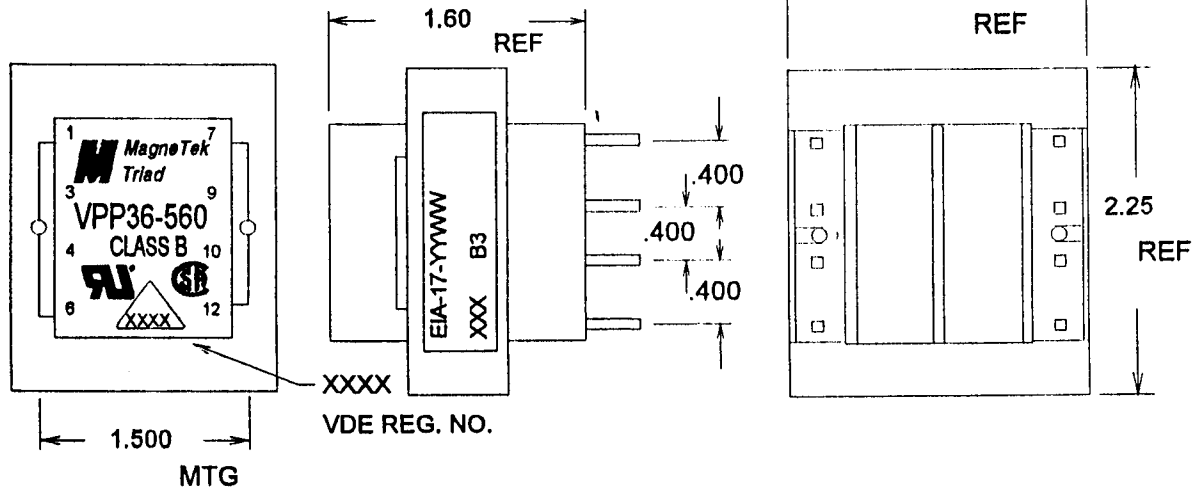

PC PINS .036 SQ

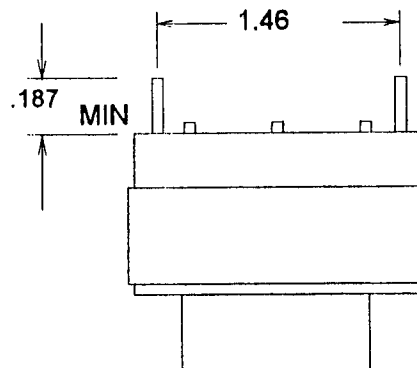

## PRODUCTION TESTS

URNS RATIO =100%

DC RESISTANCE IN OHMS	1-3 =	77 NOM
	4-6 =	90 NOM
	7-9 =	2.85 NOM
	10-12 =	3.3 NOM

MAX EXCITATION CURRENT =0.030 A

APPLY 230V 60HZ 1-6 (3+4)

PRI WDGS 114.5 TO 115.5 V

SEC WDGS 21.65 TO 21.95V

HIPOT: 4000V P-S

4000V P,S, TO CORE

600V P-P, S-S

IMPREGNATION NOTES: PREHEAT 2 HRS  
PINS TO BE FREE OF IMPREGNATION.

## FINAL ASSEMBLY NOTES

# MagneTek

METHOD 1 X 1  
LEAVE OFF LAST "I" PCS

MARKING SEE LABEL DETAIL ABOVE  
APPLY PART NO. LABEL AFTER IMPREGNATION

VPP36-560