

# PBL 3726/19

## Universal Speech Circuit

### Description

PBL 3726/19 is a standard version of the PBL 3726 family of mask-programmable, monolithic integrated speech circuits for use in electronic telephones.

It is designed for use with a piezoceramic microphone and receiver. However since both gain and input impedance of the microphone amplifier and the receiver output swing is externally adjustable, any type of microphone or receiver can be used, (piezoceramic, dynamic or magnetic receivers and piezoceramic, dynamic, magnetic microphones or FET-buffered electret microphones). Transmitting and receiving gain is regulated with line length and or signal strength, ie "soft clipping". Different regulation for various current feeds can be set by external resistors. Typical current feeds such as 48 V 2 x 200 ohm, 48 V 2 x 400 ohm and 36 V 2 x 500 ohm can be handled. Application dependent parameters like impedance to the line, side tone level, gain and frequency response are set by external components. Parameters are set independently which means easy adaption for various market needs. The DC-characteristic can be changed with an external resistor in order to obtain increased transmit and receive output swing. This option can also be used to adjust the DC-level at MUTE when working in parallel with a dialer.

### Key Features

- Soft clipping. All active components included
- Minimum number of inexpensive external components, 5 capacitors and 13 resistors.
- Mute function for operation with DTMF-generator.
- Transmit and receive gain regulation for automatic loop loss compensation.
- Differential microphone input for good balance to ground. (Common mode rejection)
- Balanced receiver output stage.

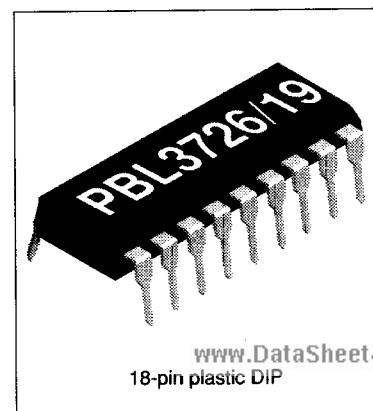
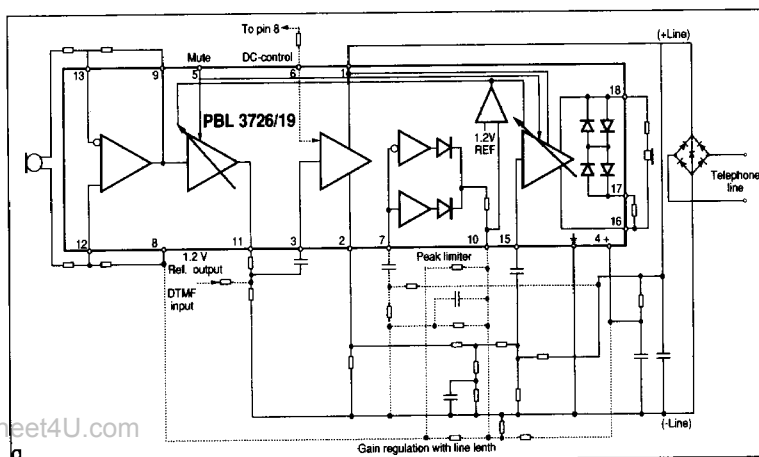

www.DataSheet4U.com  
18-pin plastic DIP

Figure 1. Functional diagram.

### Maximum Ratings

Parameter	Symbol	Min	Max	Unit
Line voltage, $t_p = 2$ s	$V_L$	0	22	V
Line current, continuous	$I_L$	0	130	mA
Operating temperature range	$t_{Amb}$	-40	+70	°C
Storage temperature range	$t_{Sig}$	-55	+125	°C

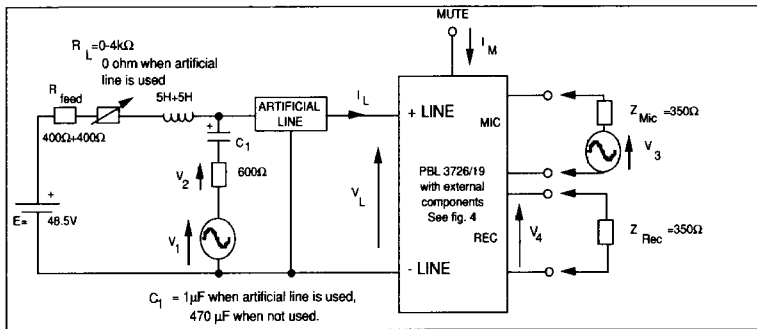

Figure 2. Test setup without rectifier bridge.

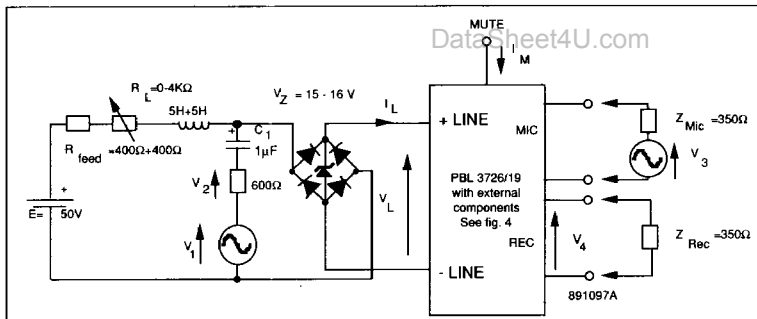

Figure 3. Test setup with rectifier bridge.

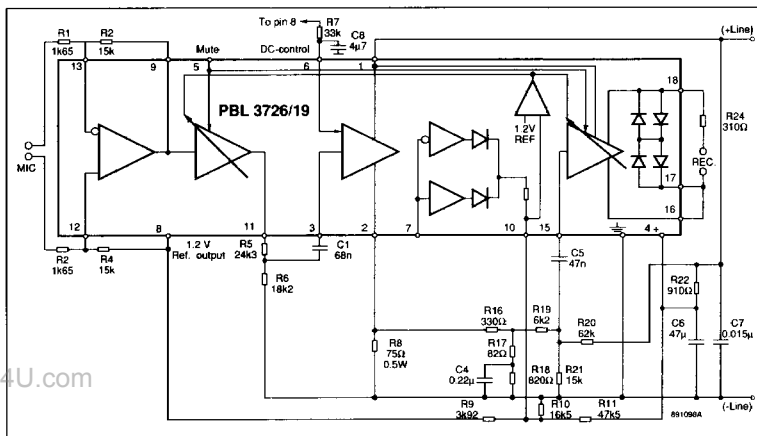

Figure 4. Circuit with external components for test setup.

## Electrical Characteristics

At  $t_{Amb} = +25\text{ }^{\circ}\text{C}$ . No cable and no line rectifier unless otherwise specified.

Parameter	Ref. fig.	Conditions	Min	Typ	Max	Unit
Line voltage, $V_L$	2	$I_L = 20\text{ mA}$		4.3		V
	2	$I_L = 100\text{ mA}$		13		V
Transmitting gain (note 1)		$20 \cdot 10 \log (V_2/V_3)$ ; 1 kHz				
	2	$R_L = 0\ \Omega$	41	43	45	dB
	2	$R_L = 400\ \text{ohm}$	43.5	45.5	47.5	dB
	2	$R_L = 900\ \text{ohm-2.2 kohm}$	46	48	50	dB
Transmitting range of regulation	2	1 kHz				
		$R_L = 0\text{ to }900\ \text{ohm}$	3	5	7	dB
Transmitting frequency response	2	200 Hz to 3.4 kHz	-1		1	dB
Receiving gain (note 1)		$20 \cdot 10 \log (V_4/V_1)$ ; 1 kHz				
	2	$R_L = 0\ \text{ohm}$	-18.5	-16.5	-14.5	dB
	2	$R_L = 400\ \text{ohm}$	-16	-14	-12	dB
	2	$R_L = 900\ \text{ohm-2.2k}\Omega$	-13.5	-11.5	-9.5	dB
Receiving range of regulation	2	1 kHz, $R_L = 0\text{ to }900\ \text{ohm}$	3	5	7	dB
Receiving frequency response	2	200 Hz to 3.4 kHz	-1		1	dB
Microphone amplifier input impedance		See note 2		3.4		kohm
Transmitter dynamic output	2	200 Hz-3.4 kHz, $\leq 2\%$ distortion $I_L = 20\text{ -}100\ \text{mA}$		2.0		$V_p$
Transmitter max output	2	200 Hz-3.4 kHz, $I_L = 0\text{ -}100\ \text{mA}$ $V_3 = 0\text{ -}1\ \text{V}$		3		$V_p$
Receiver output impedance	2	1 kHz (see note 2)		6(+310)		ohm
Receiver dynamic output (see note 2)	2	200 Hz-3.4 kHz, $\leq 2\%$ distortion $I_L = 20\text{ -}100\ \text{mA}$		0.9		$V_p$
Receiver max output	3	Measured with line rectifier 200 Hz-3.4 kHz, $I_L = 0\text{ -}100\ \text{mA}$ $V_1 = 0\text{ -}50\ \text{V}$		1.3		$V_p$
Transmitter output noise	2	Psoph-weighting, Rel 1 $V_{rms}$ , $R_L = 0\ \Omega$		-75		dB
Receiver output noise	2	A-weighting, Rel 1 $V_{rms}$ , with cable, 0-5 km $\varnothing=0.5\text{ mm}$ , 0-3 km $\varnothing=0.4\ \text{mm}$ .		-85		dB
Mute input current, $I_M$	2		0.1			mA
Rectifier sensitivity pin 7	2	Minimum required input signal for activation		125		mV <sub>p</sub>

### Notes

- Adjustable to both higher and lower values with external components.
- External resistor in the test set up.

## Pin Descriptions

Refer to figure 5 ( package )

Pin	Symbol	Description
1	+L	Output of the DC-regulator and transmit amplifier. This pin is connected to the line through a polarity guard diode bridge.
2	TO	Output of the transmit amplifier. This pin is connected to -L via a resistor of 47 to 100 ohm, which sets the DC-resistance of the circuit. The output has a low AC output impedance. The output signal is used to drive a side tone balancing network.
3	TI	Input of transmit amplifier.
4	+C	The positive power supply terminal for most of the circuitry inside the PBL 3726/19 (about 1 mA current consumption). The +C-pin shall be connected to a decoupling capacitor of 47 $\mu$ F to 150 $\mu$ F.
5	Mute	Mute input. Requires min 100 $\mu$ A to mute microphone and receiver amplifier.
6	DCC	Control input for setting the DC-characteristics.
7	RCI	Input to the full wave rectifier.
8	REF	Internal reference 1.2V.
9	MBF	Feedback point in microphone amplifier.
10	GR	Control input for gain regulation.
11	MO	Output of the microphone amplifier.
12	MI 1	Input to the microphone amplifier.
13	MI 2	Input to the microphone amplifier.
14	-L	The negative power terminal, connected to the line through a polarity guard diode bridge.
15	RI	Input of receiver amplifier.
16	RE 1	Receiver amplifier output. Output impedance approximately 6 ohm.
17	RL	Connection for output swing limiting. Normally connected to pin 16
18	RE 2	Receiver amplifier output. Output impedance approximately 6 ohm.

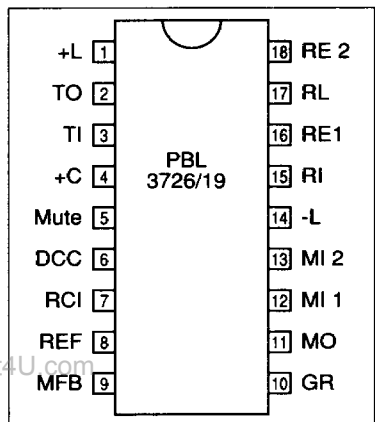

Figure 5. Pin configuration.

## Functional Description

### General

PBL 3726/19 contains all the necessary line interface functions of a modern electronic telephone.

The circuit uses a minimum of external components. In a typical application only 5 external capacitors are needed of which one is an electrolytic or tantalum filter capacitor. The other capacitors are needed as radio interference suppression capacitor across the line, one capacitor in the side-tone balancing network and one capacitor for low frequency cut-off in each of the transmitting and receiving amplifiers. The frequency response is, except for that, flat for both amplifiers.

The circuit includes a temperature independent voltage reference used for regulation of the DC line voltage and for the transmitting and receiving gain regulation. The DC voltage settles very fast to its final value with a minimum of overshoot.

The gains of the transmitting and receiving amplifiers can be continuously and equally changed with the line length.

The receiver amplifier is equipped with a high impedance input stage. This gives a less expensive RC-network on the input.

Only resistive elements are used to set the receiving gain.

A push-pull power stage in the

receiving amplifier gives a high output swing.

The outputs of the transmitting and receiving amplifiers have internal limitations of the output amplitudes.

The circuit will with external components get very good return loss characteristics, both against purely resistive lines like for instance 600 ohm and against complex networks like 900 ohm in parallel with 30 nF.

The microphone input is balanced for optimal common mode rejection.

It is possible to add a push-button controlled cut-off of the transmitting amplifier to the circuit without any disturbance of the other circuit functions.

### Design procedure:

1. The circuit's impedance to the line.
2. DC-characteristic
3. Gain regulation.
4. Transmitter gain and frequency response.
5. Receiver gain and frequency response.
6. Side-tone.
7. Components to suppress radiointerference, specially the wires up to the handset.

Component ref. nr see fig.6

### R1,R2,R3,R4

Set the gain and input impedance of the microphone amplifier. If  $R1=R2$  and

$R3=R4$  the gain is  $R3/R1$  and the input impedance  $R1+R2$ .

### R5,R6,C1

Set the transmitting gain and frequency response. The sum of  $R5+R6$  should be between 30 - 50k $\Omega$ . If no DC-loading of pin 11 the impedance to ground can be lower.

### R7

Optional resistor for raising the DC-characteristics. Typical values in fig 8.

### R8

Sets the DC-series resistance of the circuit and affects other parameters such as transmit gain, sidetone balance and transmitter output swing.

### R9,R10,R11

Optional resistors that set the gain regulation slope and starting point.  $R11/R10$  set the starting point and  $R9/(R10/R11)$  the slope. (/ stands for "in parallel with").

### R12,R13,R14,R15,C2,C3

Optional components that sets the soft-clipping characteristics of the full wave rectifier.  $R13$  and  $R14$  sets the starting point versus the line signal level,  $C2$  is a coupling capacitor.  $C3$  sets the attack time and  $C3$  in conjugation with  $R15$  the decay time.  $R12$  is not essential but can be used to set a different stand by DC level at pin 10 than the level supplied by the rectifier.

### R16,R17 ,R18,C4

Set the sidetone balance.

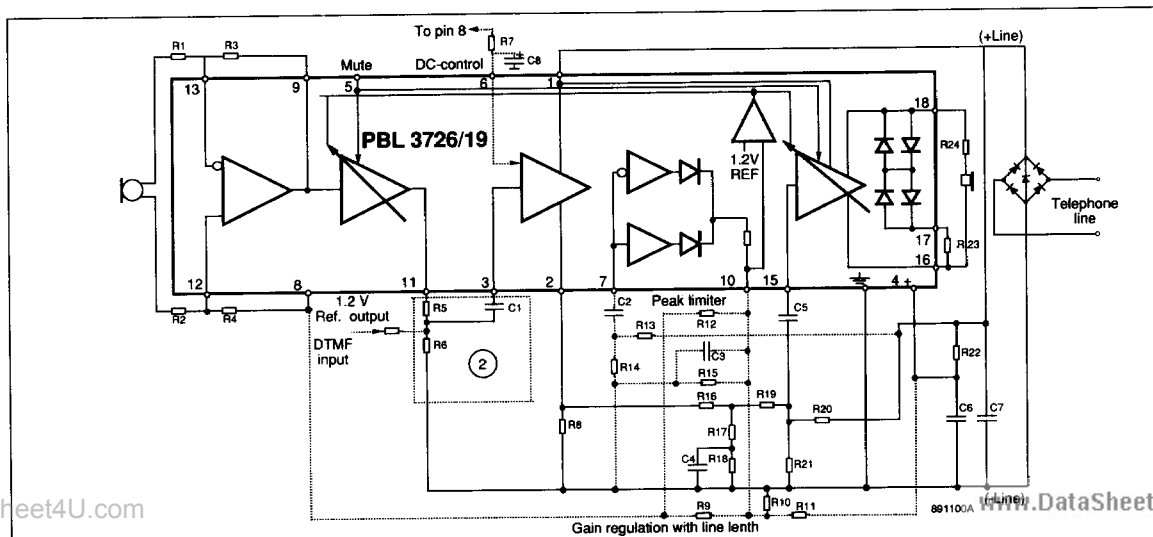

Figure 6. Standard and optional functions of the PBL 3726/19.

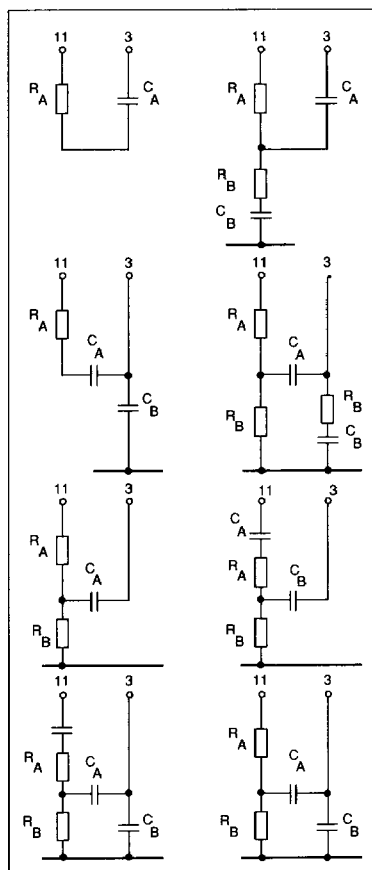

Figure 7. Examples of network with or without filtering between mic.amp and transmitter. "2".

#### R19,R20,R21,C5

Set the sidetone balance, receive gain and the receive frequency response. Gain should be adjusted with R21 which does not affect the sidetone. C5 sets the low frequency cut-off.

#### R22,C6,C7

Set the impedance to the line. C6 is also reservoir capacitor for the positive supply of the circuit. C7 is used to suppress radio interferences but may have to be completed with capacitors to ground on the microphone input and the receive output pins.

#### R23

Optional resistor for adjustment of the receiver output swing.

#### R24

Sets the receive output impedance.

#### C8

Improves the send mute. Can be omitted if a somewhat reduced attenuation at mute is acceptable.

A mute input is included in the circuit. It gives:

1. Cut-off for the output part of the microphone amplifier. (F1).
2. Reduced gain in the receiving amplifier. (F4).

Others:

The circuit can be placed either in the telephone or in the handset.

Cut-off of the transmitter can be done at F1 without interference of other functions of the circuit.

### Ordering Information

Package	Temp. Range	Part No.
Plastic DIP	-40 to +70°C	PBL 3726/19N

DataSheet4U.com

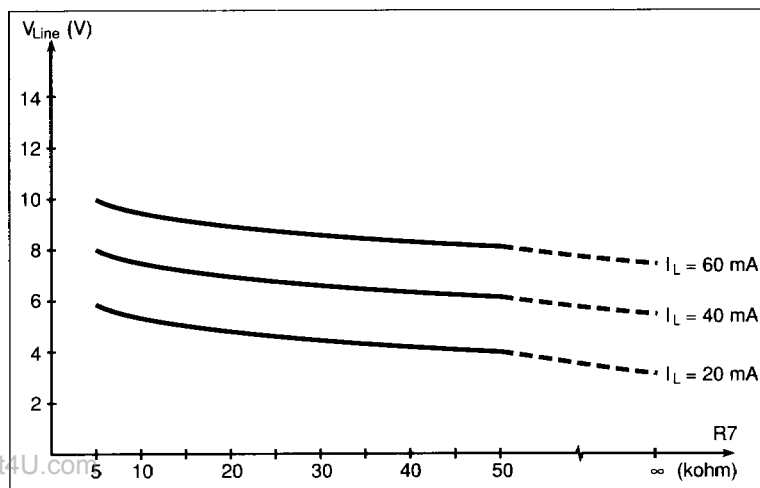

Figure 8. DC-characteristics versus R7.

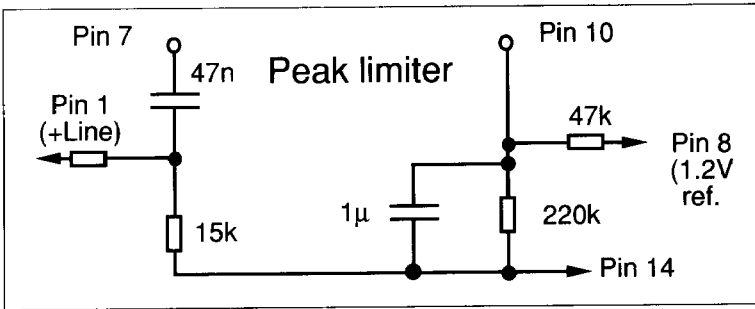

Figure 9. Peak limiter application.

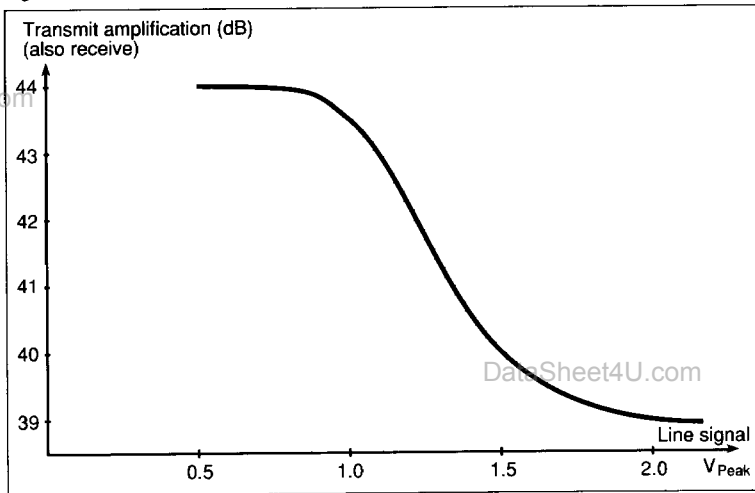

Figure 10. Peak limiter function "soft clipping according to fig.9.

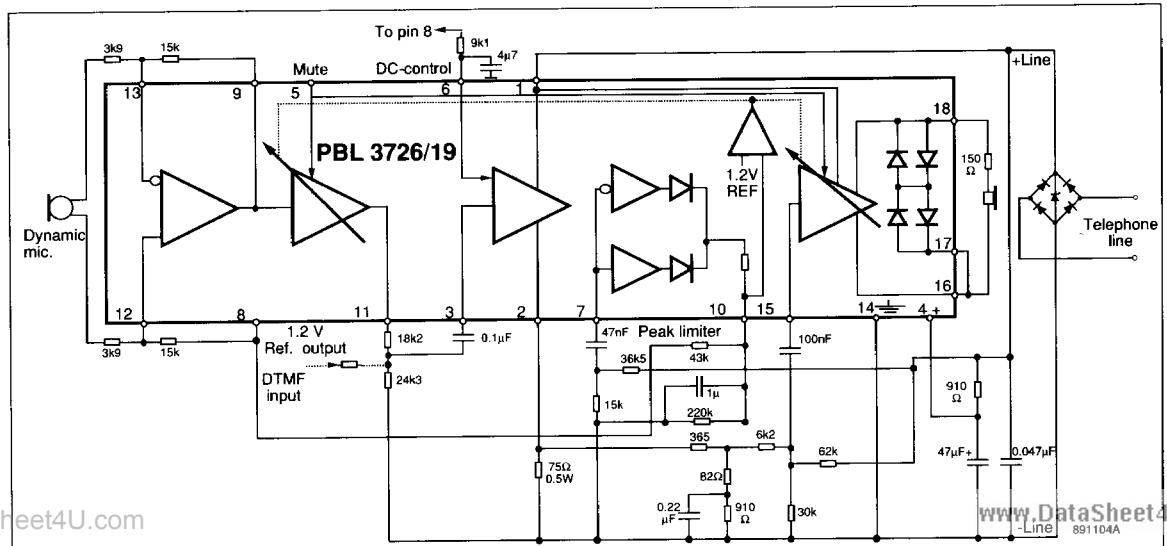

Figure 11. Application for 2x600 Ω, 60V ie. West Germany.