

Description

The ICL7106 and ICL7107 are high performance, low power 3 1/2 digit A/D converters. Included are seven segment decoders, display drivers, a reference, and a clock. The ICL7106 is designed to interface with a liquid crystal display (LCD) and includes a multiplexed backplane drive, the ICL7107 will directly drive an instrument size light emitting diode (LED) display. The ICL7106 and ICL7107 bring together a combination of high accuracy, versatility, and true economy. True differential inputs and reference are useful in all systems, but give the designer an uncommon advantage when measuring load cells, strain gauges and other bridge type transducers. Finally the true economy of single power supply operation (ICL7106), enables a high performance panel meter to be built with the addition of only 10 passive components and display.

Features

- Guaranteed Zero Reading for 0V input on All Scales
- True Polarity at Zero for Precise Null Detection
- True Differential input and Reference, Direct Display
- Drive
 - LCD ICL7106
 - LED ICL7107
- Low Noise-Less Than 15 μ Vp-p
- On Chip Clock and Reference
- Low Power Dissipation Typically Less Than 10mW
- No Additional Active Circuits Required
- New Small Outline Surface Mount Package Available

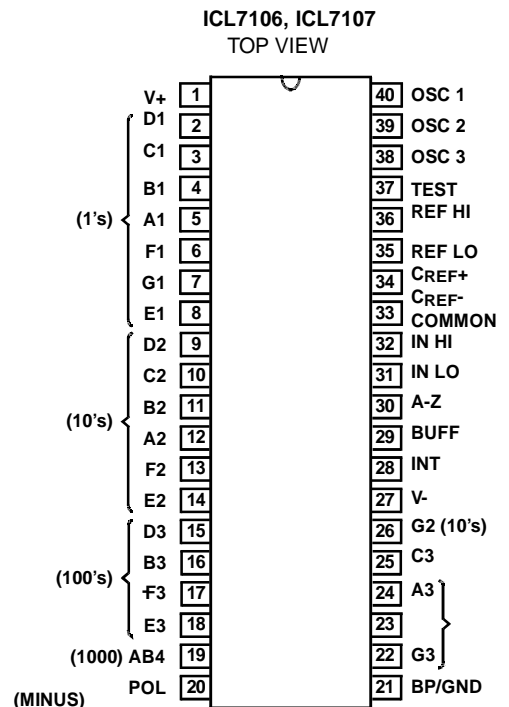

Absolute Maximum Ratings

Supply Voltage

ICL7106, V+ to V-.....15V

ICL7107, V+ to GND.....6V

ICL7107, V- to GND.....-9V

Analog input Voltage (Either input) (Note 1).....V+ to V-

Reference input Voltage (Either input).....V+ to V-

Clock input

ICL7106.....TEST to V+

ICL7107.....GND to V+

Electrical Characteristics

Parameters	Test conditions	Min	Typ	Max	Unit
SYSTEMS PERFORMANCE					
Zero input Reading	$V_{IN} = 0.0V$, Full-Scale = 200mV	-000.0	± 000.0	± 000.0	Digital Reading
Ratiometric Reading	$V_{IN} = V_{REF}$, $V_{REF} = 100mV$	999	999/1000	1000	Digital Reading
Rollover Error	$-V_{IN} = +V_{IN}$ 200mV Difference in Reading for Equal Positive and Negative inputs Near Full-Scale	-1	-	+1	Counts
Linearity	Full-Scale = 200mV or Full-Scale = 2V Maximum Deviation from Best Straight Line Fit (Note 5)	-1	-	+1	Counts
Common Mode rejection Ratio	$V_{CM} = 1V$, $V_{IN} = 0V$, Full-Scale = 200mV (Note 5)	-	50	-	uV/V
End Power Supply Character V+ Supply Current	$V_{IN} = 0$ (Does Not include LED Current for ICL7107)	-	-	1.8	mA
End Power Supply Character V- Supply Current	ICL7107 Only	-	-	1.8	mA
COMMON Pin Analog Common Voltage	25 k Ω Between Common and Positive Supply (With Respect to + Supply)	2.4	-	3.2	V
DISPLAY DRIVER ICL7106					
Pk-Pk Segment Drive Voltage	$V_{+} = \text{to } V_{-} = 9V$	4	5	6	V
Pk-Pk Backplane Drive Voltage					
Segment Sinking Current (Except Pin 19 and 20)	$V_{+} = 5V$, Segment Voltage = 3V	5	8	-	mA
Pin 19 Only		10	16	-	mA
Pin 20 Only		4	7	-	mA

NOTES:

- Input voltages may exceed the supply voltages provided the input current is limited to $\leq 100 \mu A$
- Unless otherwise noted, specifications apply to both the ICL7106 and ICL7107 at $T_A = +25^{\circ}C$, $f_{CLOCK} \leq 48kHz$. ICL7106 is tested in the circuit of Figure 1. ICL7107 is tested in the circuit of Figure 2.
- Not tested, guaranteed by design.

Typical Applications Circuit

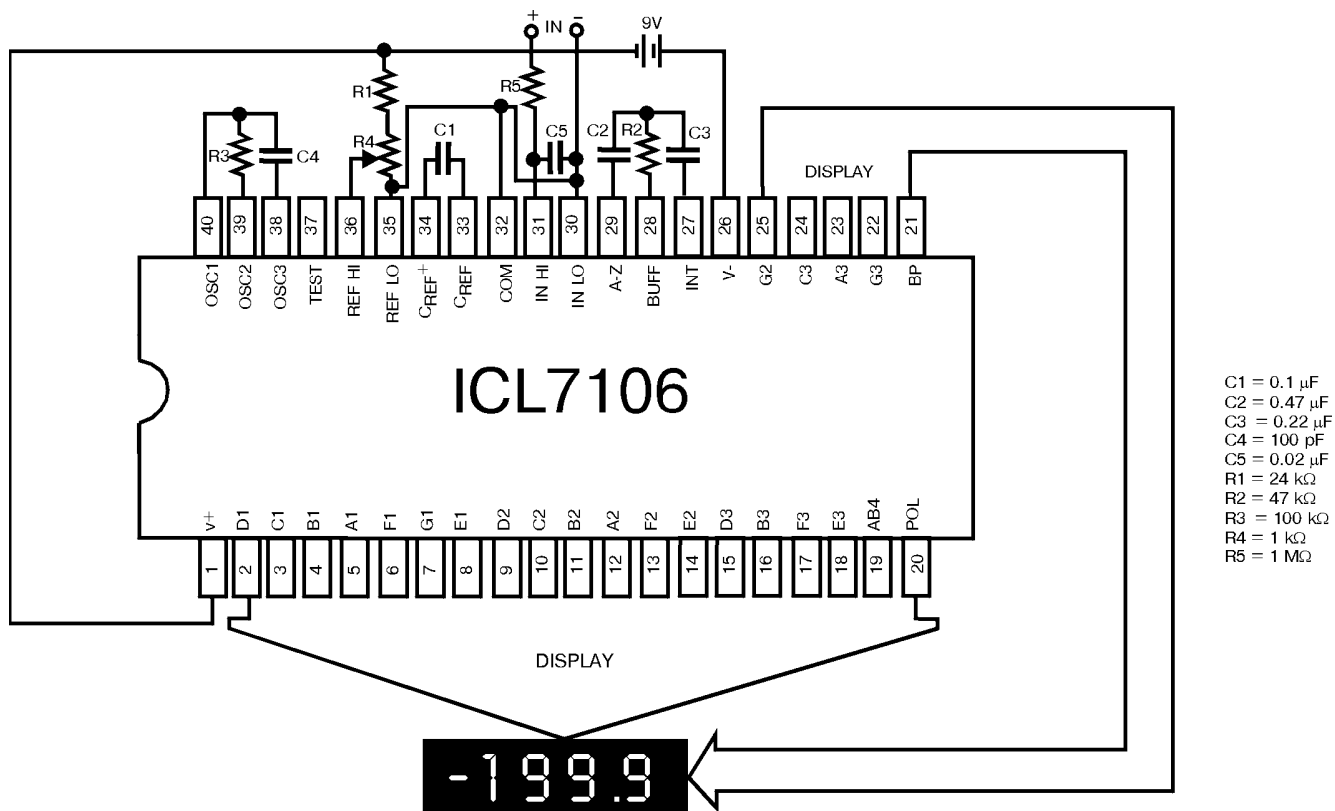

Figure 1. ICL7106 Test circuit and typical application with LCD display components selected for 200 mV full scale

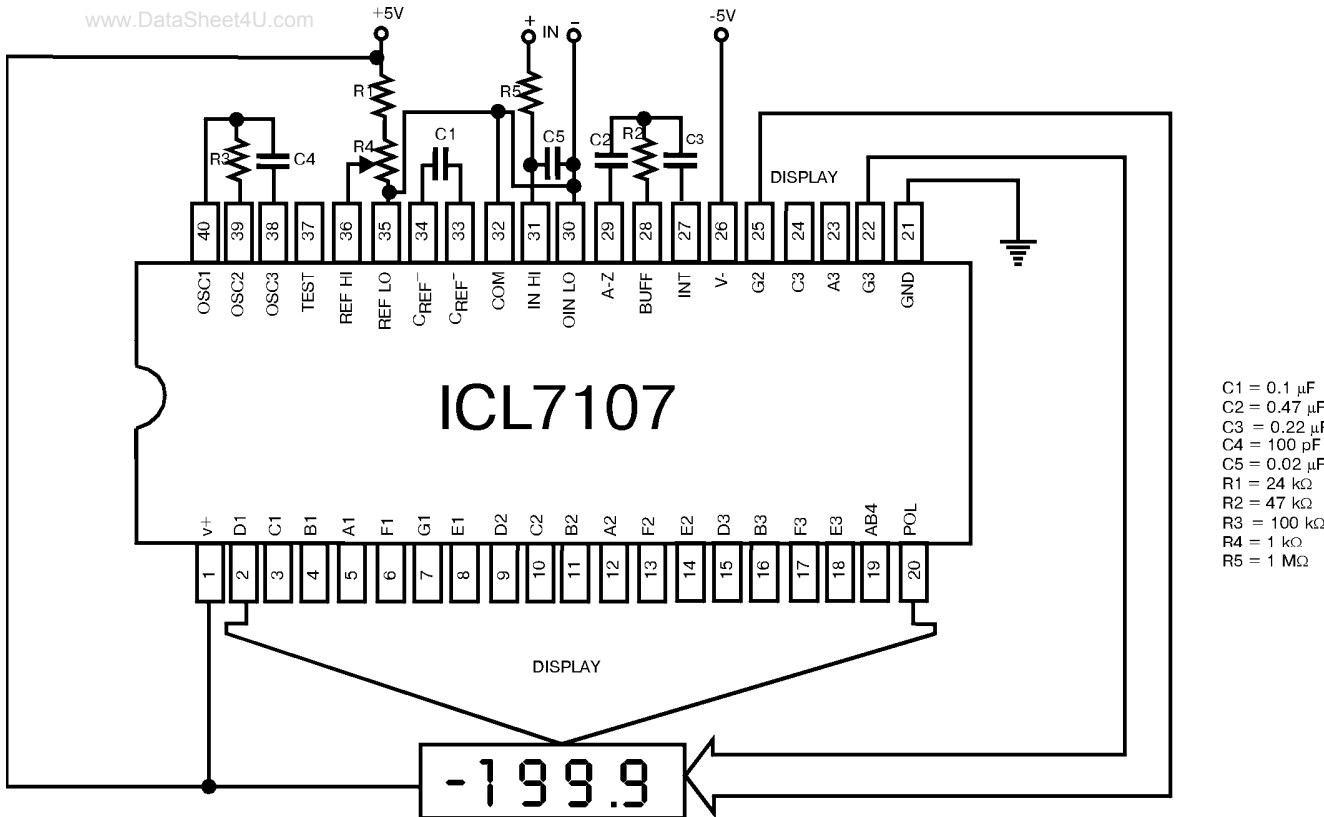

Figure 2. ICL7107 Test circuit and typical application with LED display components selected for 200 mV full scale

Ordering Information

ORDERING NUMBER	PACKAGE	MARKING
ICL7107	DIP - 40	ICL7107

Address : 北京市海淀区永定路 88 号长银大厦 6A06--6A07

Rm 6A07, Changyin Office Building, No.88, Yong Ding Road, Hai Dian District, Beijing

Postalcode: 100039

Tel: 86-010-58895780 / 81 / 82 / 83 / 84 Fax : 010-58895793

Http://www.estek.com.cn

Email: sales@estek.com.cn

REV No:01-060811